

# PureFlow<sup>®</sup>

## MANABLOC<sup>®</sup> Manifold Plumbing System

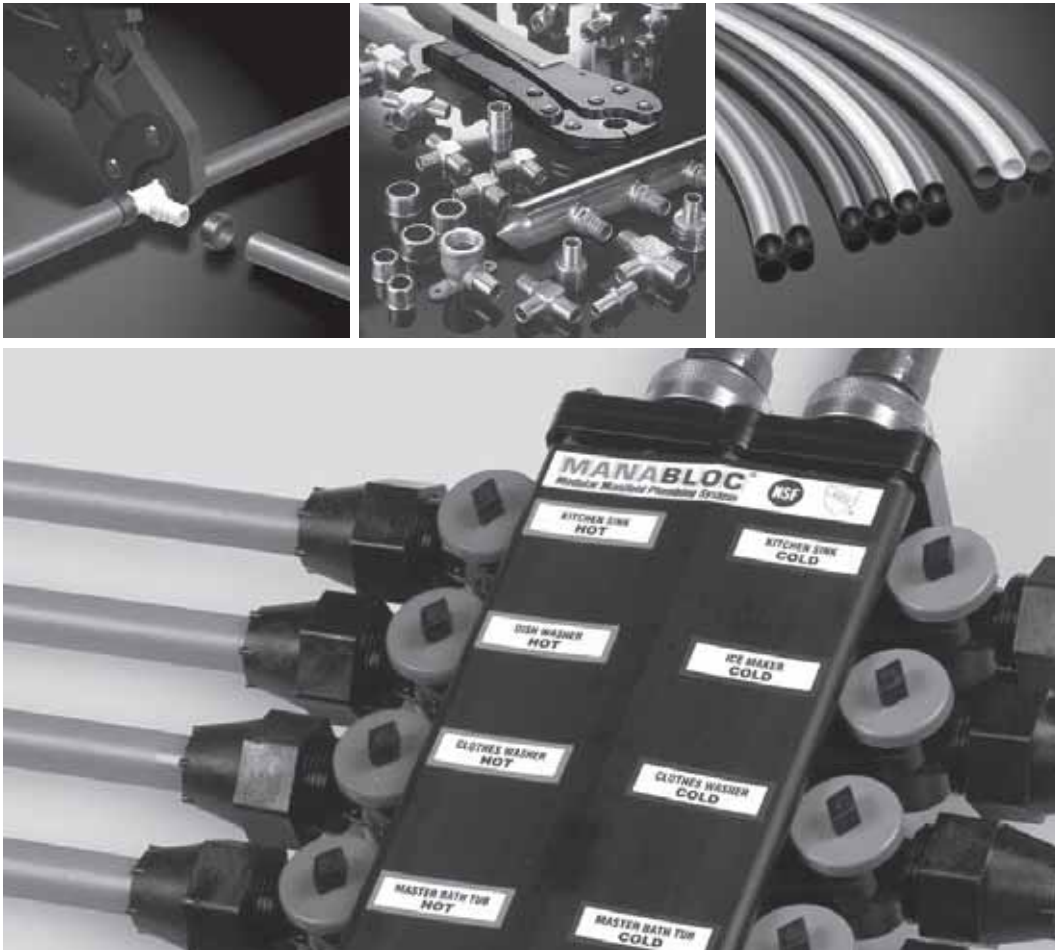

## Installation Manual



October, 2007



PureFlow is a registered trademark of Viega LLC  
MANABLOC is a registered trademark of Viega LLC  
ViegaPEX is a trademark of Viega LLC  
FostaPEX is a registered trademark of Viega GmbH & Co. KG  
Copyright March 2007 Viega LLC, All rights reserved.

## Working with Viega is the perfect solution.

Viega researches, develops and produces complete system solutions for contractors. The components are produced at our plants or are supplied exclusively by the finest quality manufacturers. Each of our systems is developed in-house and tested under stringent quality control conditions to guarantee safety and efficient operation.

## An international company with a national commitment.

Viega PureFlow plumbing combines technology from both sides of the Atlantic into the very best PEX plumbing systems for our customers.

Viega's reach extends throughout North America with distribution across the US, Canada and Mexico. Our network of sales experts and wholesale distributors can meet your needs whether you are in Boston or Berkeley. The products we deliver are the finest quality offered at a highly competitive price. Our goal is to remain on the forefront of the plumbing industry well into the new century, and with our advanced products and a determination to remain the quality leader, we are convinced this accomplishment is well within our reach.

Call 877-VIEGA-NA for your local representative and wholesale location.

## IMPORTANT NOTICE

This installation guide is intended for the MANABLOC® Manifold Plumbing System, including the MINIBLOC Manifold Plumbing System Installation Instructions.

NOTE: References to ViegaPEX™ tubing made throughout this publication include the entire line of Viega cross-linked polyethylene products.

## Why you can depend on Viega PureFlow.

- A safe system
- Competitively priced
- Leak proof fitting connection
- Highly flexible and kink resistant
- Lightweight and easy to handle
- Fast and solder free installation
- No open flame during installation
- Reduced number of fittings used in wall
- Water Savings
- Long life expectancy
- Quick Hot Water Delivery
- Non-corroding
- Reduced flow noises
- In coils or straight lengths
- FostaPEX form stable tubing ideal for exposed runs
- Listed by NSF to meet the requirements of ANSI 14 and 61 and NSF Protocol P171 (CL-R/CL-TD)
- Listed to ASTM F876/F2023 and F877

IN THE EVENT OF CONFLICT OR INCONSISTENCY BETWEEN THESE INSTALLATION GUIDELINES AND LOCAL BUILDING OR PLUMBING CODES, LOCAL CODES SHOULD TAKE PRECEDENCE.

NOTE: Failure to follow the installation instructions will void the Viega Plumbing Warranty. NOTHING IN THIS PUBLICATION IS INTENDED TO CREATE ANY WARRANTY BEYOND VIEGA'S APPLICABLE WRITTEN WARRANTY.

For additional information, contact Viega at 877-VIEGA-NA.



# CONTENTS

## 1 Introduction

- 1.1 Viega ..... 4
- 1.2 PureFlow System Concepts ..... 5

## 2 Green Building

- 2.1 General ..... 6
- 2.2 Structured Plumbing ..... 6
  - 2.2.1 Parallel Systems ..... 6
  - 2.2.2 Branch and Main Systems ..... 7
  - 2.2.3 Combination Systems ..... 7
  - 2.2.4 Domestic Hot water  
Circulating Systems ..... 8

## 3 Code Compliance

- 3.1 Plumbing Code Compliance  
(Parallel Systems) ..... 9
- 3.2 Sizing of Parallel Water  
Distribution Systems  
(MANABLOC) ..... 9
- 3.3 Valve Requirements  
for Parallel Systems ..... 9

## 4 The MANABLOC

- 4.1 The MANABLOC ..... 10
- 4.2 PureFlow PEX Tubing ..... 10
- 4.3 Supply And Distribution  
Line Sizing ..... 10
- 4.4 Overview And Carton Contents ..... 11
- 4.5 Location ..... 11
- 4.6 Valve Operation ..... 12
- 4.7 Domestic Hot Water  
Circulation Systems ..... 13

- 4.8 Multiple MANABLOC Installations ..... 13
- 4.9 ViegaPEX General  
Design/Installation Practices ..... 13

## 5 Mounting the MANABLOC

- 5.1 Mounting The MANABLOC  
Between Studs ..... 15
- 5.2 Mounting The MANABLOC  
Without Use Of MBB2 Straps ..... 17
- 5.3 Surface Mounting The MANABLOC ..... 17

## 6 Installing Distribution Lines

- 6.1 Installing Distribution Lines ..... 19
- 6.2 Connecting Distribution Lines  
to the MANABLOC ..... 19
  - 6.2.1 Compression Connections  
(3/8" & 1/2" ports) ..... 20
  - 6.2.2 PEX Press Connections  
(1/2" ports) ..... 20
  - 6.2.3 PEX Crimp Connection  
(1/2" ports) ..... 21
  - 6.2.4 Crimp Connection  
(3/8" ports) ..... 21
- 6.3 Connecting Distribution  
Lines To Fixtures ..... 22
- 6.4 Water Supply Connections ..... 23

## 7 Filling and Testing ..... 25

## 8 System Disinfection

- 8.1 General ..... 26

### Terms Used In This Guide:

PEX.....	ViegaPEX cross-linked polyethylene tubing
AHJ.....	Authority Having Jurisdiction
PPM.....	Parts Per Million
NSF.....	NSF International, Inc. (formerly National Sanitation Foundation)
CAN/CSA.....	Canadian Standards Association
"shall".....	Required; a mandatory procedure
"may" or "should".....	A suggested optional procedure

# 1. INTRODUCTION

## 1.1 Viega

For over 100 years, Viega has been a globally trusted name in the plumbing industry.

Through innovative techniques, sophisticated technologies, and acquisition of the top PEX plumbing products in the US, Viega has become the industry leader for PEX plumbing.

Viega produces a comprehensive range of plumbing and heating equipment. Anywhere water flows in a building Viega manufactures a system to fit. The company's experience with press fitting technology in bronze, stainless steel, and copper led to the development of the PureFlow water distribution system. With the acquisition of Vanguard Piping Systems and the integration of their PEX plumbing products into the PureFlow line, Viega

is now positioned as the number one supplier of PEX plumbing systems in North America.

Today, Viega engineers and manufactures over 12,000 system components at five state-of-the-art factories including our PEX tubing facility located in the heart of the US. Viega quality has proven itself in millions of systems installed around the world. Viega has a history in North America of technological innovation and customer service that is second to none.

The Viega product line now is comprised of multiple brands; ProPress® flameless copper joining technology; PureFlow® flexible PEX tubing plumbing technology; ProRadiant comfortable efficient heating technology; and S-no-Ice® snow and ice melting technology, to name a few.

Each line is selected so that components work together to create a complete system concept. PureFlow plumbing provides complete PEX systems for potable water distribution, including manifolds, PEX and multilayer tubing, fittings, and valves. The ProRadiant program includes a wide range of hydronic radiant systems and controls as well as thermostats.

In addition, the Viega S-no-Ice line includes snow and ice detection controls, heat exchangers, and snow melting systems.

As the pioneer in combining technology and engineering expertise from both sides of the Atlantic into the very best systems for our customers in North America, we are proud to present you the world's finest potable water distribution systems: PureFlow. The name says it all.

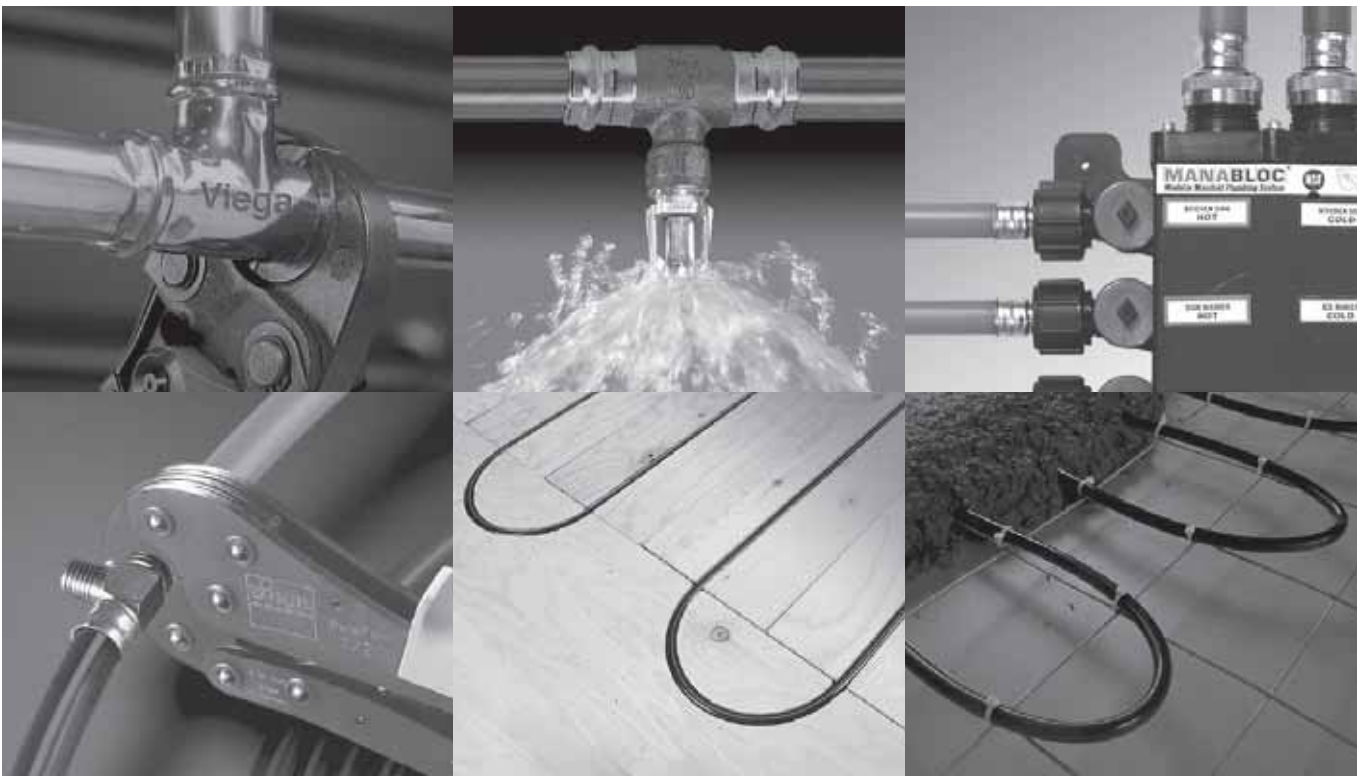

## 1.2 PureFlow System Concepts

ViegaPEX PureFlow is a high quality flexible PEX system for hot and cold potable water distribution.

The PureFlow plumbing system offers maximum security thanks to cold press and full circle crimp fitting techniques. These fittings guarantee shorter installation times for all types of applications, and vastly reduces the required number of fittings.

Top quality materials such as brass, bronze, stainless steel, and durable, environmentally compatible plastics provide the basis for the very highest standards of quality at Viega.

PEX tubing offers outstanding versatility. A total of 236 million feet of PEX tubing for potable water applications was produced in 2004 alone, and provides conclusive evidence of its importance in plumbing installation. This is clearly the result of

excellent workmanship, fast and simple installation and the reliability and safety which are characteristic of the Viega system concept.

The efficiency of the integrated system concept for Viega branded products is confirmed by:

- perfectly coordinated components
- quick delivery at short notice
- time-saving installation
- complete installation of an entire system from one supplier

Viega's comprehensive services include technical support and warranty coverage, subject to the exclusive use of PureFlow system components.

PureFlow is a high-quality plumbing system. It is able to withstand high levels of thermal and mechanical stress (80 psi at 200°F, 100 psi at 180°F, 160 psi at 73.4°F).

### The systems incorporate:

- ViegaPEX tubing; red, white and blue cross-linked polyethylene tubing designed with superior chlorine resistance
- ViegaPEX Ultra tubing; red, white, blue, and black cross-linked polyethylene tubing with added resistance to UV
- Viega FostaPEX tubing; cross-linked polyethylene with additional aluminum and polyethylene layers to provide rigidity and form stability, available in red or silver to differentiate hot water lines
- A range of bronze, brass or plastic fittings for both PEX Press and PEX Crimp fitting systems
- A range of inline, manifold and stop valves for both press and crimp fitting systems
- Viega PureFlow press tools and jaws for the PEX Press fitting systems
- Viega PureFlow crimp tools for the PEX Crimp fitting systems



## 2. GREEN BUILDING

### 2.1 General

Green Building incorporates environmental considerations into every phase of the home building process where multiple factors are considered during construction as well as its operation and its impact on the environment. LEED® (Leadership in Energy and Environmental Design) was established by the U.S. Green Building Council (USGBC) as a system to define and measure "green building". This voluntary market driven rating system is based on existing proven technology, awarding credits for different aspects of environmental design. There are four levels of performance that can be achieved per these resource categories, they are Certified, Silver, Gold, and Platinum.

Viega's PureFlow plumbing systems can be incorporated to improve both water and energy efficiency supporting this philosophy, earning your home credits toward a LEED certification level (when following LEED installation criteria). To obtain more information concerning LEED certification for your home, contact the USGBC.

The MANABLOC Manifold is a unique plumbing system that can also be incorporated to provide water and energy savings combined with a superior plumbing system for homeowners. It's a simple concept that provides extraordinary performance: each fixture is fed by its own flexible water distribution line, which runs from a central manifold. By providing each fixture with its own distribution line, the line can be sized appropriately so hot water can be delivered more rapidly. Since the line is dedicated to a single hot or cold fixture, less water is required to purge the line, which saves time, energy and can reduce water waste by up to 40% and save thousands of gallons of water per year.

#### *Clean System And Clean Installation*

The MANABLOC is preferred by many installers thanks to its fast and safe installation. There are no fumes from solvents to contend with and no torches required on site for installation. Installation time is significantly less than that of a rigid plumbing system due to the flexibility of ViegaPEX™ tubing and the simplicity of the PureFlow® fitting systems. Viega tubing is color coded to make installation easier and the connection of fixtures to the proper distribution line faster and more foolproof. Homeowners can be assured of the purity of the system due to the third party NSF-61 certification carried by both the MANABLOC and ViegaPEX tubing. Homeowners also benefit from the corrosion resistance of ViegaPEX, which helps to prevent contamination of drinking water.

#### *Fewer Fittings Behind The Wall*

The MANABLOC requires fewer fittings than branch and main plumbing systems and very few are needed behind the wall. The MANABLOC is installed using flexible ViegaPEX tubing that can be bent around obstacles without the need for fittings. In most cases each dedicated line has a fitting at the MANABLOC and one at the fixture connection with no fittings located behind the walls.

#### *Rich In Homeowner Benefits*

Home Builders enjoy the many features the MANABLOC system offers their customers over branch and main plumbing systems including:

- Faster Hot Water Delivery – properly sized lines deliver hot water up to four times faster
- Better Control of the Plumbing System – individual shutoff valves provide a simple way of servicing a fixture or adding on to the system

- Quiet Operation – Flexible ViegaPEX tubing reduces water hammer noise and provides quiet operation
- Balanced Water Delivery – multiple fixtures can be used simultaneously without noticeable pressure or temperature changes.

### 2.2 Structured Plumbing

Structured plumbing is the practice of installing and/or designing a plumbing system in a manner that enhances the systems performance by reducing water waste and hot water delivery times. This plumbing strategy is rapidly becoming important for home builders in markets where water conservation is prevalent. Viega, being the leader in innovation and technology for the plumbing and heating systems, has embraced this philosophy with its plumbing products.

#### 2.2.1 Parallel Systems:

Using manifolds (see illustration below), the installer can plumb a house with no fittings hidden inside walls. By installing a manifold system near the hot water source, tubing can be run directly to each fixture without using further fittings. This system provides the lowest pressure losses

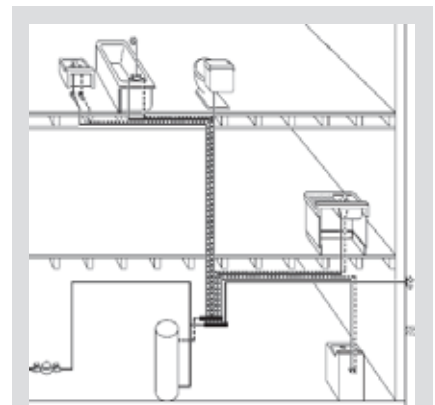

as well as eliminating interference between fixtures. Often each fixture can be fed with smaller diameter tubing which is easier and faster to install.

### ★ **Design Factors For Installing A Parallel System**

#### • **Water Heater Placement**

This should be as close as possible to the MANABLOC to minimize extra water from being stored in the larger hot water supply lines between the MANABLOC and water heater.

The longer this hot water supply line is the greater the volume of water requiring purging through the faucet before hot water is available. This causes greater water waste and longer hot water delivery times.

#### • **Proper Water Distribution Line Sizing To Each Fixture**

This is crucial for over all system performance. If you over size a distribution line to a fixture (1/2" PEX line supplying a sink instead of a 3/8" PEX line) you are essentially doubling the volume of water being stored in that line. This can take roughly twice as long to purge compared to properly sizing the line.

The fixture is what dictates water flow (federally mandated, governed by code). The tubing simply applies a friction lost dictated by its size and length. Therefore, as long as you do not under size a distribution line or run it excessive distances (60 feet or greater), the system will perform properly maintaining sufficient pressure and flow.

#### • **The Length Of A Distribution Line Run To Each Fixture**

This can drastically affect the performance of a MANABLOC system, the longer the line is the more water being stored within it, and therefore, the longer it will take to purge it out before hot water can reach the fixture.

This is just as important as properly sizing each distribution line. The MANABLOC should be located somewhat central to your fixture groups keeping within 60 feet or less of each fixture.

If you can not accomplish this with one MANABLOC you may need to use two MANABLOCs, locating one at each end of the home to split the distribution line distance between them (see section 4.8 for use of multiple MANABLOCs).

## 2.2.2 Branch and Main Systems

This method of plumbing is commonly referred to as a conventional plumbing system, or branch and tee systems, which uses copper/rigid tubing with tee and elbow fittings.

This system uses a large diameter "main" supply line (minimum 3/4") for both hot and cold water supplies that runs throughout a structure to or near each fixture group with smaller "branch" lines teeing off the main to supply each fixture.

While this system can reduce the amount of tubing used it requires more fittings to be used, which can increase installation time and cost.

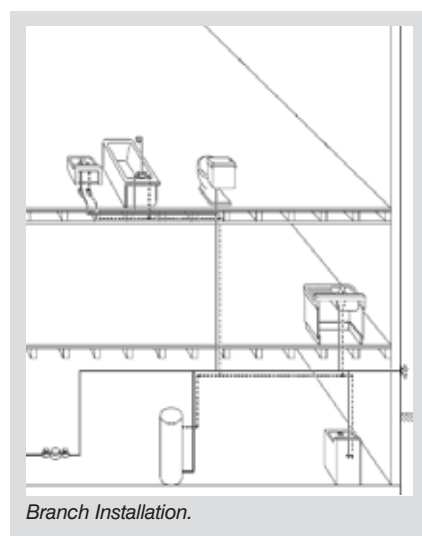

*Branch Installation.*

### ★ **Design Factors For Installing Branch And Main Systems**

#### • **Design the layout as condensed as possible**

Keep the main hot supply line close to the fixture groups with the branch lines shorter than 6 feet. This will help provide hot water in a reasonable amount of time with a more tolerable amount of wasted water.

The limiting factor for installers to accomplish an optimal design is how spread out the fixture groups are within the structure.

If the builder did not put any thought into keeping the fixture groups condensed, a branch and main system will have terrible hot water delivery times with substantial water waste.

If you have a floor plan that incorporates stacked or back to back fixture groups then a branch and main system can be an effective alternative to a parallel system.

One disadvantage to these systems is they store excess amounts of water in the large main lines, therefore the further away the fixture is, the longer the main supply line must be to reach it, purging all stored water out before hot water reaches the fixture.

Another trait these systems suffer from is noticeable pressure drop during multiple fixture use. When you turn on multiple fixtures you are increasing the water flow (load) within the main line, causing higher friction loss equal to pressure loss at the point of use. This is why you notice a drop in pressure (and potentially a temperature change) in your shower when a toilet is flushed.

## 2.2.3 Combination Systems

A combination system uses multiple manifolds combined with a branch and main type supply system. These systems use small manifolds

located throughout a structure placed near each main fixture group and are supplied by the main hot and cold supply lines similar to the branch and main system. The manifolds essentially branch multiple lines from a common location in lieu of multiple tee fittings spread out. This takes advantage of benefits from both types of systems and helps keep hidden fittings to a minimum.

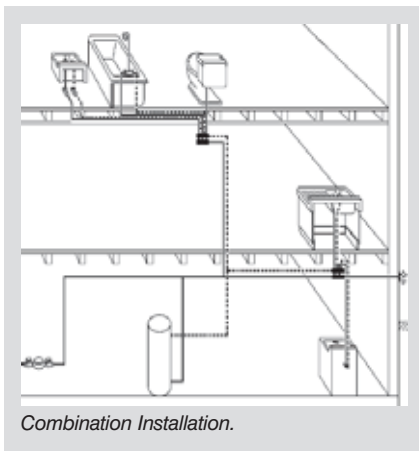

Combination Installation.

### ★ **Design factors for installing combination systems**

Just like the branch and main system, condensed floor plan layouts are preferable to minimize hot water main supply lines being stretched out everywhere. This additional water requires purging prior to hot water being present at each fixture. These systems can also suffer from fluctuating pressure during multiple fixture use.

## 2.2.4 Domestic Hot Water Circulating Systems

A hot water circulation system can be incorporated in most plumbing systems and works by constantly (or periodically throughout the day on a timer) circulating hot water through the main hot supply line of your plumbing system. This is done by use of a return line at the end of the main hot supply line, and a low flow pump (usually near the hot water tank). It keeps hot water readily available

throughout the entire main hot water supply line eliminating the need to purge the entire line before hot water is present at the fixture.

There are a number of hot water circulation systems available in the market place that offer a variety of options.

These systems are ideal for branch and main or combination systems with spread out fixture groups/floor plans, as well as for larger homes using multiple MANABLOCs in a parallel type system.

### ★ **Design Factors For Hot Water Circulation Systems**

#### • **Installing a hot water circulation system**

You will want to use either a gas or electric tank water heater. Use of a tankless or instantaneous type water heater will drastically increase the operating cost of the system.

There are many types of these systems available on the market today. Research which type is best for the particular application. Insure all the components being used within the circulation system are rated and/or approved for a hot water circulation system. These systems may require some maintenance and/or repairs over time which could include complete pump replacement.

Note: There are costs associated with running these systems due to the electricity required to operate the pump, this will vary depending on the frequency of operation and size of the pump.

## 3. CODE COMPLIANCE

### 3.1 Plumbing Code Compliance (Parallel Systems)

The MANABLOC parallel water distribution system meets the ASTM F877, standard specification for cross-linked polyethylene (PEX) plastic hot and cold water distribution system utilizing ViegaPEX tubing meeting the requirements of the ASTM F876, standard specification for cross-linked polyethylene tubing.

The 2006 International Plumbing Code® (IPC) and the 2006 Uniform Plumbing Code™ (UPC) recognize and list these ASTM standards within their respective mandatory standards and/or approved material sections.

The MANABLOC is IAPMO listed to the UPC utilizing both 3/8" and 1/2" PEX tubing sizes for distribution.

### 3.2 Sizing of Parallel Water Distribution Systems (MANABLOC)

Sizing of Parallel Water Distribution Systems (MANABLOC) are addressed in both the IPC and UPC 2006 plumbing codes.

In the IPC, section 604.5 Size of fixture supply states, "The minimum size of individual distribution line utilized in gridded or parallel water distribution systems shall be as shown in Table 604.5." This table includes 3/8", 1/2" and 3/4" size tubing. In the UPC, section 610.4 it states, "Listed parallel water distribution systems shall be installed in accordance with their listing, but at no time shall any portion of the system exceed the maximum velocities allowed by the code." The MANABLOC's IAPMO UPC listing says to install per the manufacturers current installation instructions. Therefore, these instructions shall be used to size and install these types of systems.

### 3.3 Valve Requirements for Parallel Systems

The IPC and UPC codes address valves in sections 604.10.3 Valves, and 605.5 respectively, which allow the use of manifold valves in parallel systems in lieu of valves at the fixture, as long as they are installed at the manifold and are identified with the fixture being supplied.

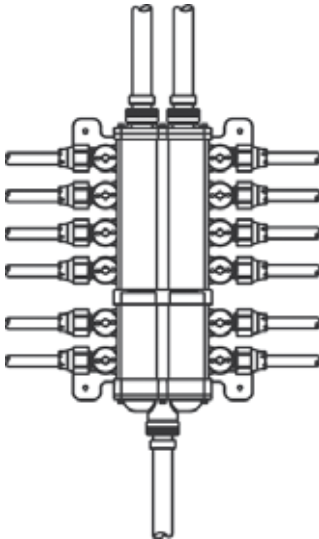

## 4. THE MANABLOC

### 4.1 The MANABLOC

The MANABLOC control unit is tested to the requirements of ASTM F877 and certified by NSF International. The MANABLOC supply inlet connections utilize a special 1" MANABLOC gasketed swivel connection that requires MANABLOC transition fittings (not included in the MANABLOC package, must be purchased separately). Transition fittings available include NPT male thread, brass insert (PEX crimp), bronze insert (PEX press), and compression.

Connections for the individual PEX distribution lines are a mechanical-type fitting and will not work with standard pipe fittings. Use only fittings supplied with the MANABLOC or other fittings designed for special port transitions available from Viega, listed in the PureFlow Plumbing System Catalog. Warranty coverage applies ONLY when the MANABLOC is installed with ViegaPEX tubing and in accordance with the Installation Instructions, local code and good plumbing practices.



Protect the MANABLOC from construction debris, direct exposure to sunlight and inadvertent chemical exposure by storing it in its original shipping carton until installation.

MANABLOC port connections are available in Bronze Press, Brass Crimp, Poly Crimp, and Compression available in all 3/8", 1/2" or a combination of both for all connection types as well as a model for hard and soft water systems.

### 4.2 PureFlow PEX Tubing

Components utilized in the MANABLOC plumbing system consist of ViegaPEX, ViegaPEX Ultra, and FostaPEX cross-linked polyethylene tubing, fixture transition fittings, water

service swivel connections, compression port connections and the MANABLOC control unit. The MANABLOC and ViegaPEX tubing are manufactured to national and international standards and are listed by recognized third-party agencies.

ViegaPEX cross-linked polyethylene tubing is produced to ASTM F876/F877 and is tested and listed by recognized agencies (such as NSF International) to the requirements of these standards. ViegaPEX tubing has a design pressure rating of 100 psi @ 180°F, and 160 psi @ 73°F.

These are maximum-use ratings. ViegaPEX tubing and the resin used in the manufacture of ViegaPEX tubing have been tested and listed by NSF to meet the requirements of ANSI/NSF 14/61, and NSF Protocol P171 CL-R/CL-TD, Chlorine Resistance of Plastic Piping Materials.

### 4.3 Supply And Distribution Line Sizing

The general sizing information shown may be appropriate for many MANABLOC installations. These recommendations are based on flow rates of typical fixtures that require 8 psi residual pressure.

For more complete and definitive sizing information for distribution line length limitations, request the MANABLOC Tube Size Guide from your local supplier or from Viega.

Typical supply line size:

3/4" up to 2-1/2 baths  
1" up to 4-1/2 baths

Typical distribution line size:

**3/8" up to 2-1/2 GPM** fixture flow requirement (lavs, toilets, bidets, bar sinks, kitchen sinks, dishwashers, some showers (no tub fill)\* and some washing machines)\*\*

**1/2 up to 4 GPM** fixture flow requirement (hose bibbs, tubs, showers, washing machines, whirlpool baths, soaking tubs, etc.)

\* Due to the many types of shower valves, it is recommended that you consult the valve manufacturer's literature to determine the actual flow rate and required residual pressure demands of the fixture. Use the MANABLOC Tube Size Guide to determine distribution line size and length limitations.

\*\*Some washing machines use a timer instead of a water-level sensor to determine when the machine has been filled with the proper amount of water.

There are cases in which low supply pressure or excessive distribution line length may cause some machines to fill to a level less than designed. Consult the washing machine manufacturer's literature to determine the actual fill rate and residual pressure requirements for distribution line size.

Hose Bibb Note: If the hose bibbs are primarily for irrigation purposes, they should be supplied from the main service line prior to the MANABLOC.

The service line needs to be sized appropriately for the additional water demand. A typical residential plumbing system can not be plumbed with all 3/8" distribution lines. It is the decision of the user to choose a combination of both 3/8" and 1/2" lines or to upsize the entire system to 1/2".

However, supplying fixtures with 1/2" lines when it is unnecessary for the fixture demand, will increase the wait time for hot water delivery to those fixtures. The best water and energy savings of a MANABLOC system are realized when distribution lines are

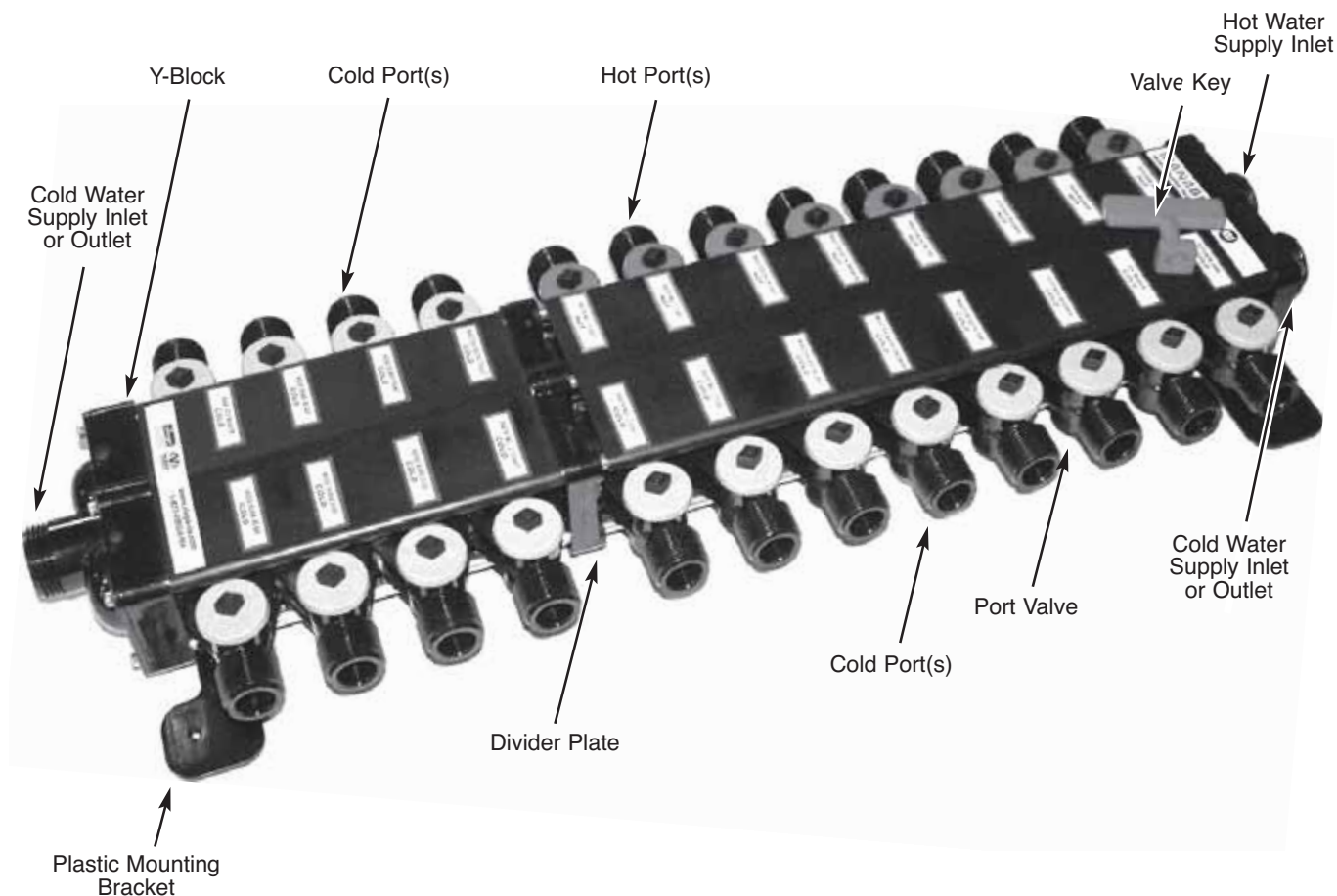

sized according to the fixture demand and the length of the individual line (see the MANABLOC Tube Size Guide for details on sizing a typical system).

A MANABLOC with all of the same size ports, can easily have some ports converted to 1/2" with optional PEX Crimp adapter MXLSA33 (3/8" port to 1/2" tube).

Conversely, 1/2" ports can be converted to 3/8" with optional PEX Crimp adapter MXLDC24, or PEX Press adapter MXPDC24 (1/2" port to 3/8" tube).

Note: Each port converted to a larger or smaller size requires one adapter and one PEX Crimp ring or PEX Press sleeve (sold separately).

#### 4.4 Overview And Carton Contents

Additional package contents include:

- Valve T-Handle
- Instruction/Warranty Packet - to be left at installation site
- Port Labels

#### 4.5 Location

*Before installing the MANABLOC, review the following instructions.*

NOTE: The MANABLOC is much like an electrical breaker box. When a fixture needs repair, the line to that fixture may be shut off at the MANABLOC, eliminating the need to shut down the water supply for the entire house.

This feature requires that the MANABLOC be accessible after installation.

1. Under no circumstances shall the MANABLOC be located in a permanently covered area (behind sheetrock, plywood, paneling), where freezing temperatures may occur, or in direct sunlight. THE MANABLOC MUST BE ACCESSIBLE and there shall be sufficient clear area in front of the MANABLOC to provide access.
2. When local code allows, the MANABLOC unit can be mounted in a fire rated wall provided the access door meets the same rating requirements as the wall and is installed over the access opening.

3. When installing the MANABLOC in a location other than between studs, provisions must be made to support the tubing runs as they exit the MANABLOC. (See section 5).
4. Any installed cover panel shall allow access to the MANABLOC and its mounting screws, the port valves, distribution line connections and supply line connections.
5. To maximize potential water and energy savings, the MANABLOC should be mounted as close as is practical to the hot water source, taking into consideration the following:
  - a. When the MANABLOC is mounted above the water heater, there shall be a minimum of 36" of connecting tubing between the water heater and the MANABLOC to reduce the chance of heat stacking;
  - b. When the MANABLOC is mounted beside the water heater and is connected with tubing incorporating a horizontal flow, it

shall be connected with at least 18" of tube length. Mounting the MANABLOC within 8 (eight) feet of developed tube length of the water heater will minimize delivery time of hot water to individual fixtures.

- c. The unit should be installed in an area which is centrally located to the most dense concentration of served fixtures. Some applications will require that the MANABLOC be mounted further than eight (8) feet from the hot water source. See page 5 for suggestions to reduce hot water delivery time in these instances.
6. DO NOT install the MANABLOC within a continuously recirculating hot water plumbing loop. The MANABLOC, however, may be supplied from a recirculating hot water loop. (See figure below.)
7. Position the MANABLOC so that it can be securely fastened through the holes provided in the mounting

brackets. The mounting surface should be as flat as possible so as not to induce any twisting or bending forces on the unit. The MBB2 Mounting Straps simplify mounting between studs on 16" centers.

#### 4.6 Valve Operation

A MANABLOC system, which has valves on all of the outlet ports, does not require stop valves at the fixtures. However, the Authority Having Jurisdiction (AHJ) may require stop valves at some fixtures.

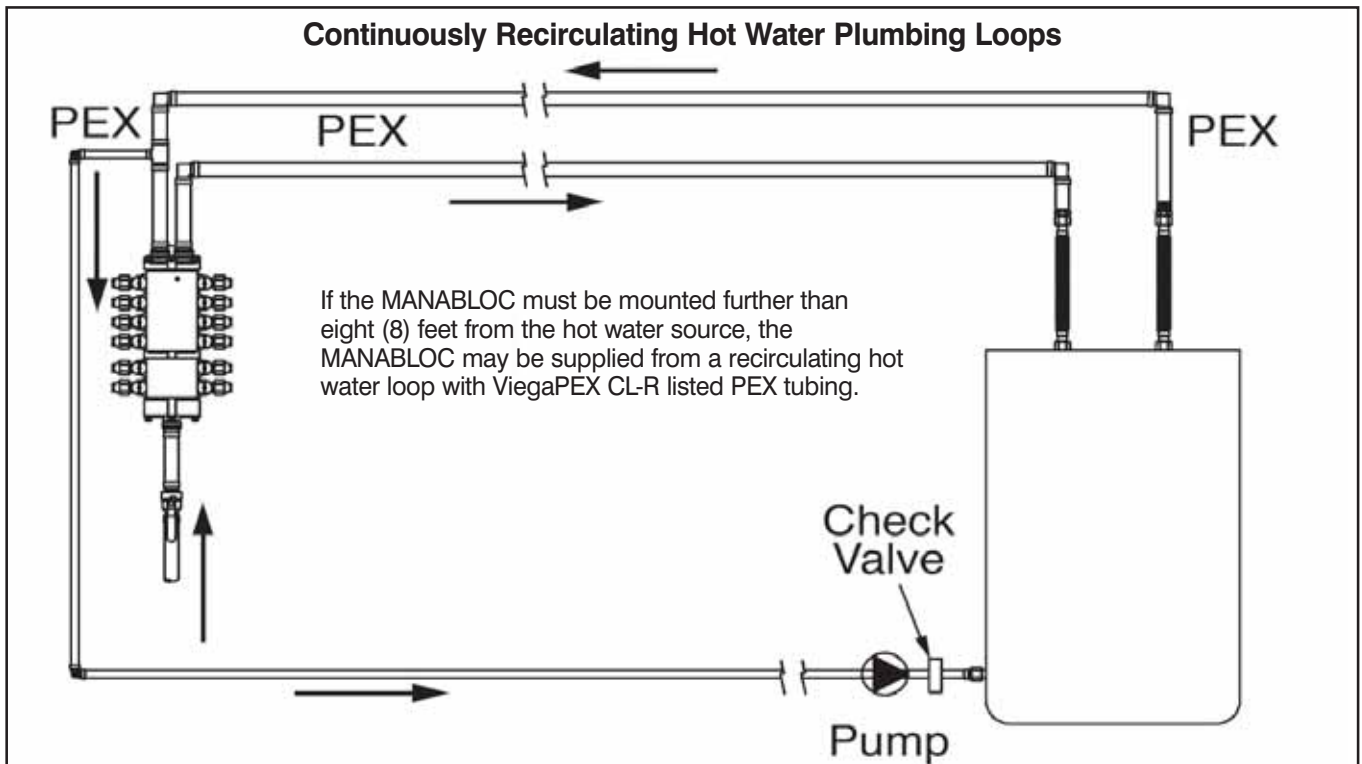
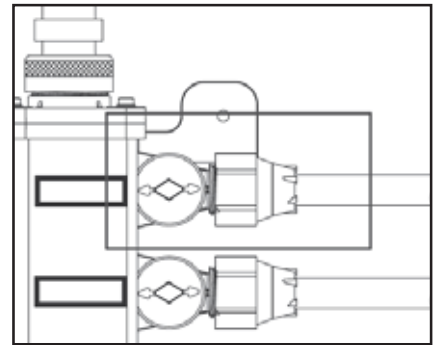

Note: these valves are field-repairable. Contact Viega Customer Service for more information on this procedure.

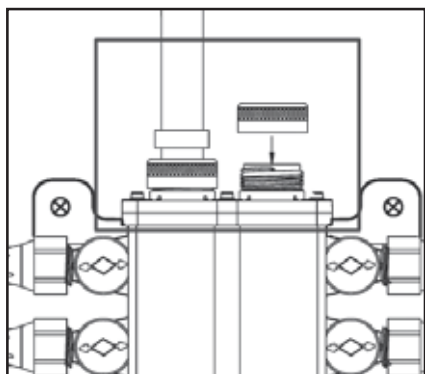

If a main inlet/outlet will not be used, it must be capped (use Part No. ECAP1).

The main service line to the MANABLOC may include a main shut-off valve, as required by local code. Although a shutoff valve for the main service line at the MANABLOC itself is not required, it can be a beneficial option for a homeowner and is recommended.

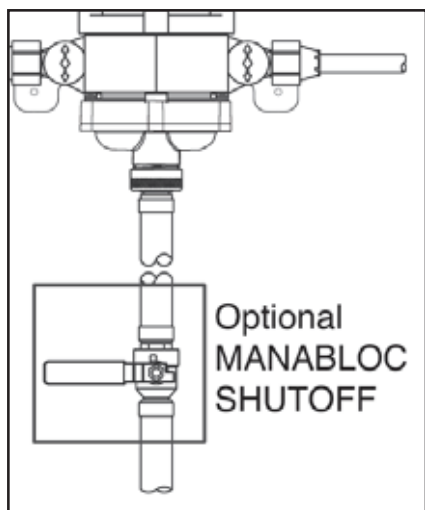

Local code may also require the installation of a check valve, PRV (pressure reducing valve), back flow preventer, etc. To prevent debris and other particles from entering the system, a strainer may be installed in the service line.

## 4.7 Domestic Hot Water Circulation Systems

ViegaPEX and the MANABLOC can be used in continuously recirculating domestic hot water plumbing loops, provided:

1. The plumbing loops shall operate with water temperatures of 140°F or lower, as required by most model plumbing codes.
2. The recirculating loop is for supplying hot water more quickly to the MANABLOC, not to circulate through it or the distribution lines. DO NOT include the MANABLOC within a continuously recirculating loop.

NOTE: The distribution lines and the MANABLOC are not to be part of the circulating system. The loop is to provide hot water more quickly to the MANABLOC only.

## 4.8 Multiple MANABLOC Installations

If a home requires multiple MANABLOCs to service the number of fixtures in the home, these guidelines should be followed if the MANABLOCs are closely located to each other.

- Consider dividing high demand fixtures between the units.
- Consider a reasonable division, i.e. upstairs/downstairs, east/west or front/back.

### Locating a Remote MANABLOC

A remote MANABLOC is sometimes recommended to achieve maximum efficiency from your MANABLOC system.

- It can be advantageous when the line lengths are excessive from one centralized MANABLOC unit.
- When the home requires more than one unit due to the number of fixtures or size of the home, you

may want to consider locating a remote unit near an outlying group of fixtures.

## 4.9 ViegaPEX General Design/Installation Practices

This section only addresses general design/installation practices for ViegaPEX tubing, refer to the PureFlow® Water Systems Installation Manual for more detailed instructions.

Insulating each PEX tube individually or as a group is not generally necessary if the PEX tubing is installed within the insulation envelope of the structure, i.e. the heated area. For example, the tubing may be installed under the insulation in the attic or within an interior wall of a heated space.

Use metallic connectors to attach PEX to gas water heaters (Viega Part No. XLSE4418, XLMSE4418 or similar fabricated metallic assembly).

Install a minimum 18" of metallic or other piping between the water heater and PEX. For electric water heaters, it is permissible to connect directly to the inlets and outlets with a brass swivel elbow or straight brass swivel fitting.

Protect the PEX tubing with non-metallic sleeving material where it enters and/or exits a slab or at mass penetrations. PEX need not be sleeved its entire length within the slab. However, full-length sleeving is allowed. Penetrations through concrete walls may be sleeved with a larger size metal or plastic tube. Protect the tubing from any sharp edges where it enters and exits larger sleeving material.

These are general guidelines to consider when installing ViegaPEX tubing with a MANABLOC system, please refer to the PureFlow installation guide for more detail on PEX tubing installations.



**COLD WEATHER CAUTION!**

The thermoplastic components of the MANABLOC, like all thermoplastics, have decreased resistance to impact under freezing conditions and could be damaged. Increased care must be exercised when installation is to occur under freezing conditions.

**BEFORE INSTALLING THE MANABLOC, MAKE SURE THE LOCATION REQUIREMENTS HAVE BEEN MET.**

Extra caution should be taken in handling the MANABLOC when temperatures are below freezing. Tubing penetrations may require sleeving or the installation of an insulator.

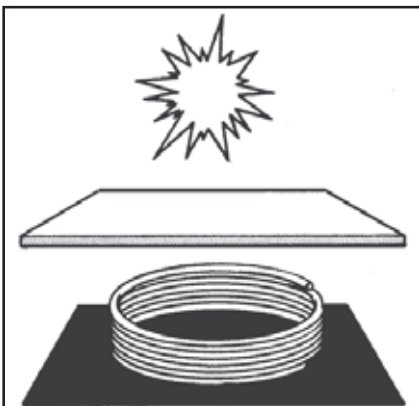

PEX tubing should always be shielded from direct or indirect sunlight.

PEX tubing shall be stored under cover, shielded from direct and indirect sunlight when the material is stored for any length of time. Short exposure times, of ViegaPEX, FostaPEX and PolyAlloy fittings, not exceeding the total accumulated recommended exposure time are permissible. See the PureFlow® Water Systems Installation Manual for more information.

When the tubing penetrates at an angle in relation to the hole, it may be subject to a sharp edge, which could damage the pipe. Acceptable sleeving materials include flexible plastic tubing, foam pipe insulation or an approved plastic insulator.

It is not generally necessary to sleeve PEX when penetrating wooden framing members or non-metallic finished or unfinished walls. However, if there is a doubt, sleeve the pipe or install an insulator.



Sleeve all penetrations of metal, metal studs, and masonry or concrete.

When penetrations must be sealed for air infiltration purposes, there are several options available. A good grade of silicone, acrylic, or siliconized acrylic caulking (DO NOT use oil-base caulks), most of the canned expanding foams, and open- or closed-cell pipe insulation are good sealing materials and may be used in direct contact with PEX tubing. Other materials may be used provided they do not cause short or long term damage to the PEX tubing.

If there is no information available on the compatibility of the proposed sealing material, wrap the tubing with several layers of aluminum foil in the area of contact and extending a few inches on both sides before applying any sealing material.

Most building codes require the use of a fire-stopping compound when tubing penetrates a fire-rated wall. There are a number of fire stopping compounds readily available that have been listed for use with PEX tubing. These compounds come in standard caulking tubes and are identified as waterbased, acrylic or latex. Consult the compound manufacturers' instructions for proper application.



**DO NOT APPLY CHEMICALS TO THIS MANABLOC PLUMBING SYSTEM**

## 5.1 MOUNTING THE MANABLOC

### 5.1 Mounting The MANABLOC Between Studs

*NOTICE! Please leave this installation guide for the homeowners reference. Local code may also require additional labeling directly adjacent to the MANABLOC or on the inside of any cover panel.*

Dimensions in these instructions are for 16" stud centers, and must be adjusted for other stud spacing.

Once the general location of the MANABLOC has been determined (see page 11 for guidelines), the MANABLOC may be mounted to a suitable surface between a pair of adjacent studs. For 16" stud spacing, the MBB2 Mounting Straps can simplify installation.

#### Tools Required

- Electric Drill
- Pencil or Pen
- Framing Square
- Tape Measure
- 3/4" and 1-1/4" Wood Drill Bits
- #2 Phillips Head Screwdriver
- Permanent Marking Pen\*
- Tubing Cutter - Stock Code 21304 or HAK67
- PEX Press/Crimp Tool(s)\*
- MANABLOC Wrench - Part No. MW1 (Compression Blocs only)

#### Additional Materials

- Wood or Drywall Screws - 1/2" or longer
  - 1/2" or 3/4" Plywood - only required when not mounting between studs
  - Nylon Ties - Part No. HB14120
  - PEX Distribution Line Tubing
  - 3/4" or 1" Supply Line Tubing
  - MANABLOC 1" Swivel Supply Fittings
  - Fixture Transition Fittings
  - Tubing Clamps and Hangers
  - MANAPANEL Access Panel\*
  - Tubing Uncoiler\*
  - Tube Turnouts (recommended)
- \* Optional or may not be required for some installations

1. Lay the MANABLOC, plastic brackets down, on a suitable flat surface that is large enough to accommodate the full-length of the MANABLOC. Place a MBB2 Mounting Strap under each plastic mounting bracket (located at the top and bottom ends of the MANABLOC). Attach the plastic mounting bracket at one end of the MANABLOC to the center two holes of a Mounting Strap using the provided self-tapping pan-head screws. The screw heads must be on the accessible side of the mounting strap. Repeat at the other end of the MANABLOC. Tighten screws securely.
2. Standing behind the studwall, measure up from the floor and make a mark on the back of one of the studs to represent the top of the MANABLOC as shown in the illustration.

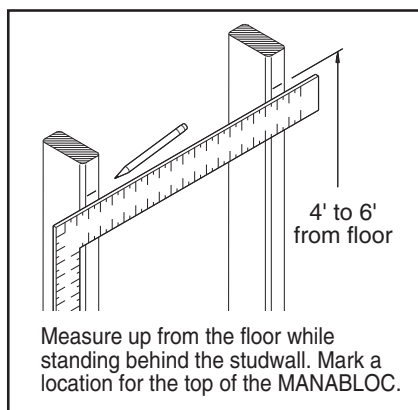

This mark should be between 4 feet and 6 feet from the floor but may be at any height, provided the height will allow all valves on the MANABLOC to be accessible. With a framing square or level, transfer and mark the noted height on the other stud.

**NOTE:** A residence intended for disabled persons may require that the MANABLOC be mounted lower in the wall to provide access.

3. Standing behind the stud wall, hold the MANABLOC facing away from you and align the top of the UPPER MBB2 Mounting Strap to the line on the stud that you made in Step 2. Loosely attach this Mounting Strap flush to the back outer edge of one stud using a 3/4" or longer drywall or other suitable wood screw (A). See illustration.

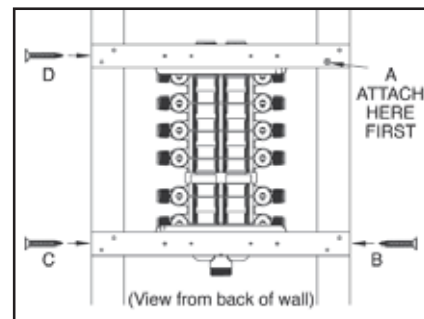

4. Line up the LOWER Mounting Strap with the back outer edge of the stud and attach it in the same manner (B). Attach the remaining strap ends (C & D) to the other stud, and tighten all screws.
5. Standing in front of the wall, use a framing square or straight edge and mark the center line position of the top and bottom ports onto both studs (see illustration).

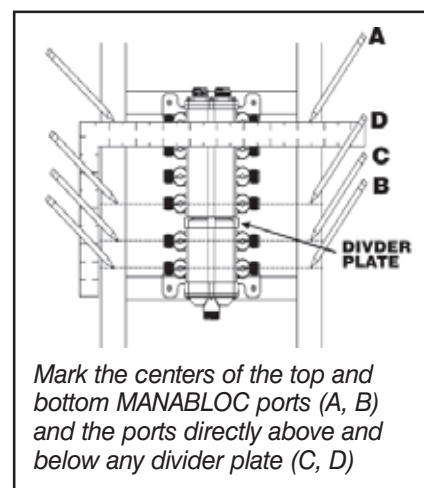

When the MANABLOC includes a divider plate, also mark the location of the ports directly above and below the divider plate onto both studs.

6. Detach the MANABLOC from its Mounting Straps (or 1 x 4s) and remove it from the installation area to prevent wood chips or other debris from falling into the unit.
7. Transfer the port location marks made in step 5 to the insides of the stud cavity using a square and pencil.
8. Measure 1-5/8" from the mounting surface. Draw a vertical line on the studs that passes through each of the horizontal port center lines marked in step 7 (see illustration). Be sure to mark the inside of both studs.
9. Push a small nail through the printed center line at one end of the Drill Guide (A). Push the nail into the cross formed where the top port mark intersects with the 1-5/8" mark. Tap the nail into the stud to hold the Drill Guide in place.
10. Push a small nail through the printed center line on the Drill Guide with the center line of the ports above the divider plate (B). Tap the nail into the stud to hold the Drill Guide in place.

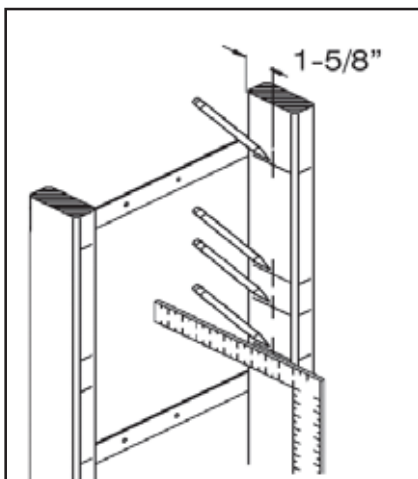

If the MANABLOC does not have a divider plate, push the nail into the printed center line of the bottom most port (E) and on into the corresponding mark on the stud. Tap the nail into the stud to hold the drill guide in place.

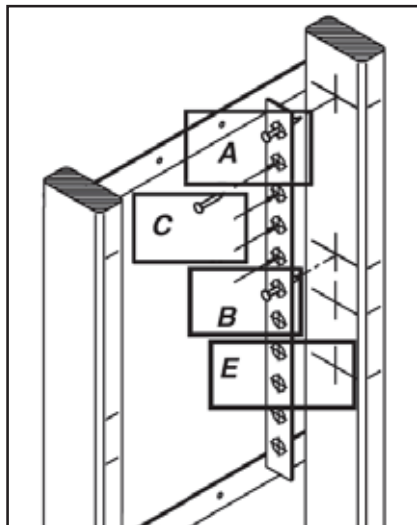

11. Using an awl, nail, or other pointed tool (C) mark the stud by tapping through the Drill Guide at each printed center line between the two nails. Carefully remove the Drill Guide. If the MANABLOC does not have a divider plate, go to step 13.
12. Marking port locations below a divider plate: Put the top nail in the Drill Guide (D) on the cross formed by the center line of the first port below the divider plate and the 1-5/8" measurement from the back of the stud. Tap the nail into the stud to hold the drill guide in place. Push another nail (E) through the center line on the Drill Guide which corresponds to the bottom port of the MANABLOC.

Then place the nail at the point on the stud where the bottom port center line intersects with the 1-5/8" measurement. Tap the nail into the stud to hold the drill guide in place. With a nail or awl (F), tap and mark the stud at each center line between the two nails.

13. Carefully remove the Drill Guide and repeat the marking procedure on the adjacent stud.

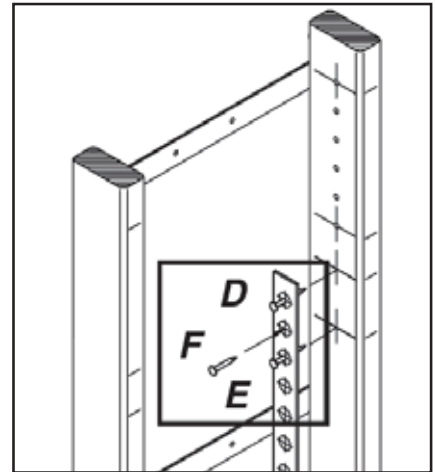

14. Drill 3/4" holes through both studs at each marked location. Be sure to hold the drill level and perpendicular to the stud to prevent drilling holes at an angle. Remove any splinters or burrs made during drilling.

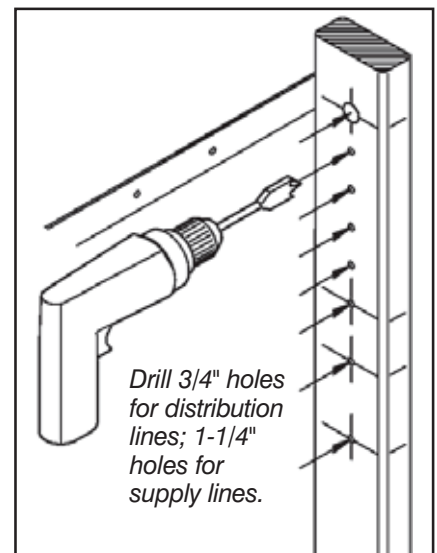

15. Mark and drill any holes for main water supply and hot water supply/return lines at this time. An 1-1/4" bit will provide adequate clearance for 3/4" or 1" tubing. The tubing shall enter and/or exit the MANABLOC in a straight line

so as not to induce bending stress on the MANABLOC. Necessary elbows, couplings, and tees are allowed in the main water supply lines.

16. Reattach the MANABLOC to the mounting straps.



When the MANABLOC is installed prior to wall finishing operations, the unit **MUST** be protected from paint, texture compounds and drywall dust.

NOTE: The wall in which the MANABLOC is to be mounted must be accessible from both sides during installation to use the MBB2 Mounting Straps.

## 5.2 Mounting The MANABLOC Without Use Of MBB2 Straps

*If not using the MBB2 Mounting Straps, this procedure applies:*

1. Cut two pieces of lumber (1 x 4 - or 3/4" plywood - about 3-1/2" wide) to a length which provides a snug fit BETWEEN two studs.

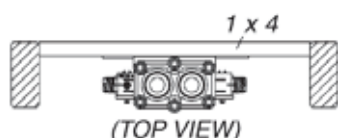

1 x 4s attach at the back, inside the studs, and the MANABLOC is centered between the studs.

2. The top of the MANABLOC should be between 4 ft. and 6 ft. from the floor (but may be at any height provided that it maintains accessibility to all of the ports on the MANABLOC).

Make a mark near the back of the inside of one stud which would represent the top of the MANABLOC.

With a framing square or level, transfer the mark to the inside back of the other stud.

## 3. ATTACHING THE MANABLOC BETWEEN THE STUDS:

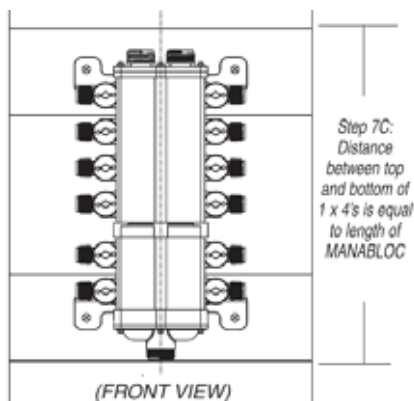

- A. Measure the total length of the MANABLOC.
  - B. Attach the first (UPPER) 1 x 4 inside and flush to the back of the studs (see TOP VIEW) at a height where the center of its width is centered on the marks from step 2.
  - C. Attach the remaining (LOWER) 1 x 4 inside and flush to the back of the studs at a distance below the upper 1 x 4 that is equal to the length of the MANABLOC (step 7A) when measured from the top of the upper 1 x 4 to the bottom of the lower 1 x 4. See FRONT VIEW illustration.
4. CENTER THE MANABLOC IN THE STUD CAVITY: Attach the MANABLOC to the 1 x 4s with four 1/2" - 3/4" drywall.
  5. Refer back to section 5, step 5.1 to finish installation.

## 5.3 Surface Mounting The MANABLOC

1. A suitable base for the MANABLOC can be constructed from a section of 1/2" or thicker plywood that is a minimum 22-1/2" wide and slightly longer than the overall length of the MANABLOC.
2. Securely attach a length of 2 x 4, or other suitable framing material with

a thickness of 1-1/2" and about 3-1/2" wide on the left and right sides of the mounting base and running the full-length of the MANABLOC (see illustration, step 4.5). The 2 x 4s will be used to secure the distribution lines at the correct height as they exit the MANABLOC.

3. Attach the mounting base to the structure in a suitable location (see page 4). The base should be mounted so the top of the MANABLOC is between 4 feet and 6 feet from the floor but may be at any height provided that the height maintains accessibility to all the ports on the MANABLOC.
4. The mounting base must be firmly attached to a structure solid enough to support, at a minimum, the weight of the MANABLOC filled with water. The base should be square and level.
5. Center the MANABLOC on the base both vertically and horizontally as shown here. Attach the MANABLOC to the mounting base with four 1/2" or longer drywall or wood screws through the holes in the plastic brackets on the MANABLOC.

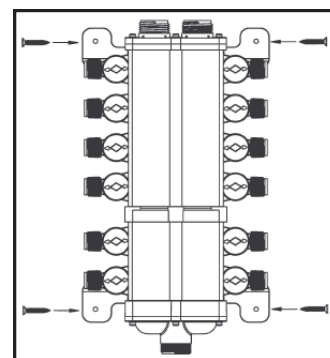

6. As the distribution lines are connected to the MANABLOC (see section 6), ensure that the tubing exits the unit at a 90 degree angle to the centerline of the MANABLOC so as not to induce bending stress on the MANABLOC.

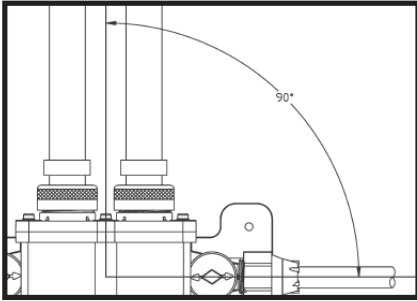

7. When attaching the distribution line tubing to the 2 x 4 supports, be sure to use appropriately-sized Viega tubing clamps (For example, use stock code 52 000 for 3/8" tubing and stock code 52 020 for 1/2" tubing).

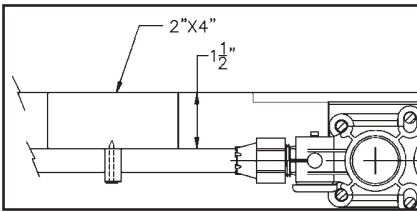

Use one clamp per tube to ensure that the tubing is held securely. Clamps shall be positioned NO FURTHER than six (6) inches from the end of the port. DO NOT pull tubing tight. Leave at least 7" of slack per 50' of tubing run.

## 6. INSTALLING DISTRIBUTION LINES

### 6.1 Installing Distribution Lines

Distribution lines should be run continuously in the most direct route from the MANABLOC to the fixtures.

A distribution line may contain a coupling or other fitting for purposes such as repairing a damaged section of tubing, handling a change of direction which cannot be made within the minimum bend radius guidelines, accommodating a fixture location change which requires a longer line, or to supply a low-demand accessory (i.e., ice maker). However, several pieces of shorter tubing should not be connected with fittings for the purpose of using up leftover lengths of tubing.

**NOTE:** It is the responsibility of the installer to ensure that further construction, finishing and other mechanical system installations do not compromise the MANABLOC plumbing system as installed according to these instructions.

1. The tubing coils are usually placed at the MANABLOC location and tubing is pulled to the fixture through stud cavities, holes drilled overhead in floor joists, etc. Several tubes may be pulled at one time. Viega's color coded ViegaPEX tubing will help prevent cross-connections.
2. Tubing should not be pulled tightly and some slack (typically, 7" per 50') is necessary to accommodate expansion and contraction. Leave enough excess tubing at the beginning and end of runs to make connections without putting strain on the tubing.
3. Care should be exercised when pulling PEX tubing to prevent cutting or abrading. Care also must be taken to prevent kinking of the

coiled tubing. If kinking or cutting should occur, these sections must be cut out and a coupling installed.

4. For the best results, connect the distribution lines to fixtures and the MANABLOC immediately upon installation, and label the end-use fixture on the MANABLOC cover plate next to the port.

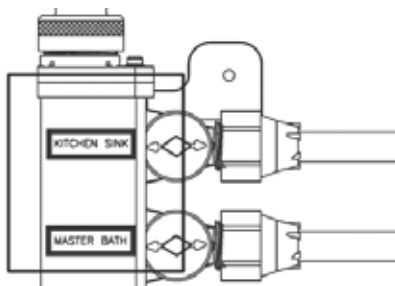

*Self-adhesive labels are supplied with the MANABLOC. Tubes pulled as a bundle, or those not connected immediately, should be marked at both ends with a permanent marker designating the fixture supplied.*

5. Since plumbing fixtures are generally located in groups, and there may be several ViegaPEX distribution lines running to approximately the same location, it is easiest to run these distribution lines bundled together.

Hot and cold lines may be run in the same bundle. For a neat appearance, bundles can be tied with nylon ties (Stock Code HB14120 or HBPT) or plastic strapping at regular intervals.

**NOTE: Bundles shall be sufficiently tied for tubing support but shall NOT restrict tubing expansion and contraction caused by temperature variations.**



**CAUTION: DO NOT USE DUCT TAPE FOR BUNDLING.** Duct tape will not permit tubing movement.

6. Bundles may be supported with hangers designed for larger tubing sizes.

7. The HB14120 or HBPT can be used to support PEX lines directly from wooden framing members.

Other plastic cable ties capable of supporting the weight of the tube or bundle when filled with water can also be used.

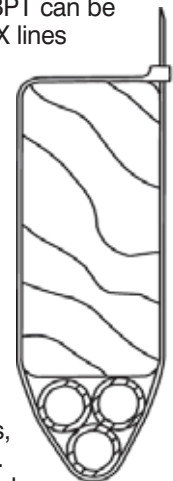

8. Holes drilled through studs, joists, plates, headers, etc. must be large enough to accommodate tubing bundles without binding, to allow free movement. Several smaller holes (accommodating a few lines each) may be preferable to drilling a bundle-size hole. In no case should the hole size exceed building code guidelines, as this could weaken the structural support members.

For more detailed instructions, refer to PureFlow Installation Guide, section 7.

### 6.2 Connecting Distribution Lines to the MANABLOC

PEX Press, PEX Crimp, and Compression connections are available and included with the MANABLOC, except Supply connections which must be ordered separately.



**UNDER NO CIRCUMSTANCES** shall any form of thread sealant (Teflon® paste, pipe dope) be used on the distribution line connections. The carriers present in these compounds can crack the plastic port connections, resulting in leaks and water damage.

## 6.2.1 Compression Connections (3/8" & 1/2" ports)

THE WATER SUPPLY TO THE MANABLOC SHALL BE TURNED OFF WHILE MAKING DISTRIBUTION LINE CONNECTIONS.

NOTE: The red caps on the MANABLOC designate hot ports, the blue caps designate cold ports. Make sure the distribution lines are being connected to the correct ports (hot or cold). The use of color coded ViegaPEX tubing also reduces the possibility of cross connections.

1. For each distribution line, slide the Lock-In compression nut (A), Lock-In insert (B) and the plastic ferrule (C) onto the tubing in that order. See illustration below.

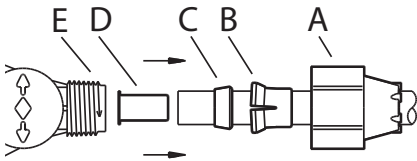

The long taper of a 3/8" ferrule (C) must be TOWARD THE END OF THE TUBE; a 1/2" ferrule is symmetrical and may be installed facing either direction. Insert the stainless steel stiffener (D) COMPLETELY into the end of the tubing.

**WARNING:** DO NOT attempt to install the Lock-In insert backwards as breakage may result. ALWAYS insert the long portion of the insert sleeve over the tube first.

DO NOT attempt to use or reuse inserts that are defective, cracked, broken or otherwise damaged, as connection failure will result.

2. Push the tubing into the port socket (E) until it bottoms out.

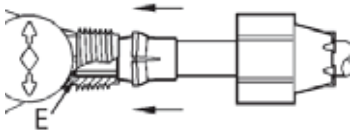

Holding the tube so that it does not back out of the fitting, slide the white Lock-In insert and ferrule snugly against the chamfer inside the port socket.

While holding the tube against the bottom of the socket, thread the Lock-In compression nut onto the port and tighten hand-tight.

3. While holding the tube securely to prevent turning, finish tightening the nut with the MANABLOC Wrench (Viega Part No. MW1) until the white Lock-In insert appears between the lugs and becomes flush with the ends of the lugs, plus 1/4 to 1/2 turn.

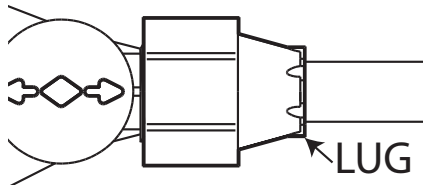

Complete the connection as soon as each distribution line is connected to the MANABLOC.

**WARNING:** DO NOT use slip-joint pliers to tighten the Lock-In nuts. Use the MW1 MANABLOC Wrench to tighten the compression connections.

**Each valve should be turned to the open position after completing each connection.**

4. After all connections are complete, recheck that all of the Lock-In inserts are visible between the lugs and are flush or protruding slightly beyond the lugs.
5. As the distribution lines are connected to the MANABLOC, they should immediately be labeled on the cover plate as to which fixture that line supplies.

Fixture labels are included with each MANABLOC. Affix the appropriate label to the cover plate next to the port.



### COMPRESSION CONNECTION CAUTION

This plumbing system relies upon the proper tightening of distribution line compression connections.

Failure to properly complete ALL connections will result in failure. Incomplete or improper connections can hold pressure during a system test but will fail at a later date, resulting in water damage.



### DO NOT OVERTIGHTEN.

Compression fittings can be OVER TIGHTENED.

Overtightening of the Lock-In compression nuts may cause damage to the tubing, nut, valve or fitting body. DO NOT tighten Lock-In nuts beyond the recommendation of these instructions (Step 3).

## 6.2.2 PEX Press Connections (1/2" ports)

THE WATER SUPPLY TO THE MANABLOC AND THE PORT VALVES SHALL BE TURNED OFF BEFORE ATTEMPTING INSTALLATION OF PRESS ADAPTERS.



### CAUTION

Use only sealing elements supplied with the adapters.

1. Slide the supplied swivel nut (D) and a press sleeve (C) 61000 for 3/8" tubing; 61020 for 1/2" onto the tubing (threads of the nut toward the end of the tubing).

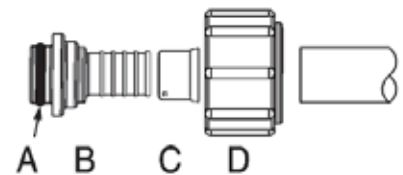

Insert the barbed end of the fitting (B) fully into the end of the tubing as shown.

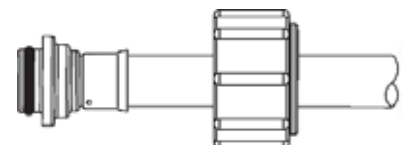

2. Check full tubing insertion at view hole of sleeve, then press the sleeve with an appropriately sized press tool. See section 5 from the PureFlow installation manual for pressing instructions.

DO NOT PRESS TWICE.



3. Insuring sealing element (A) is in place, insert the fitting into the desired port until the fitting flange sets flush with the end of the port.

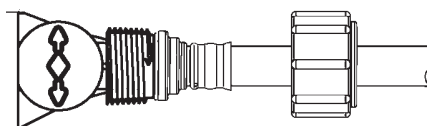

4. Slide the swivel nut (D) over the press sleeve (C) and thread the nut onto the MANABLOC port, hand tighten only.

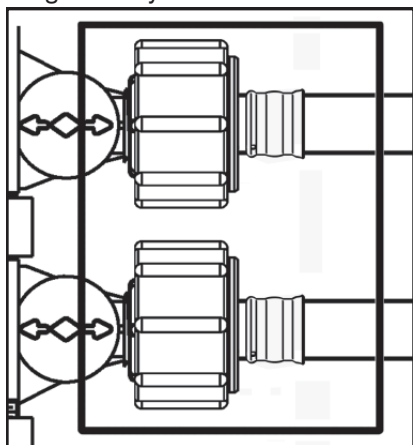

5. Open the port valve(s) before turning on the main water supply.

### 6.2.3 PEX Crimp Connections (1/2" ports)

THE WATER SUPPLY TO THE MANABLOC AND THE PORT VALVES SHALL BE TURNED OFF BEFORE ATTEMPTING INSTALLATION OF CRIMP ADAPTERS.



**CAUTION**  
Use only sealing elements supplied with the adapters.

1. Slide the supplied swivel nut (D) and a crimp ring (C) XLCR2 for 3/8" tubing; XLCR3 for 1/2" onto the tubing (threads of the nut toward the end of the tubing).

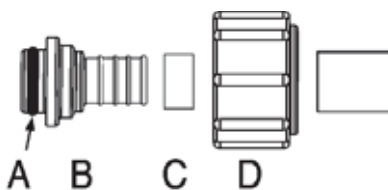

Insert the barbed end of the fitting (B) fully into the end of the tubing as shown.

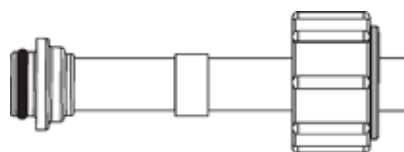

2. Insuring sealing element (A) is in place, insert the fitting into the desired port until the fitting flange sets flush with the end of the port.

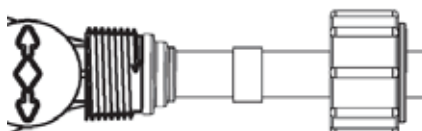

3. Slide the crimp ring (C) to within 1/8" to 1/4" from the end of tube. Crimp the ring with an appropriately sized full-circle crimp tool.

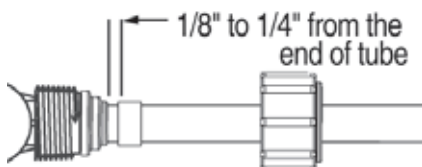

See section 6 from the PureFlow installation manual for crimping instructions.

DO NOT CRIMP TWICE.

4. Slide the swivel nut (D) over the crimped ring (C) and thread the nut onto the MANABLOC port, hand tighten only.

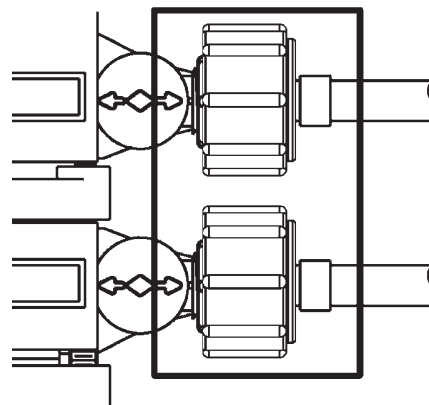

5. Open the port valve(s) before turning on the main water supply.

### 6.2.4 Crimp Connection (3/8" ports)

THE WATER SUPPLY TO THE MANABLOC AND THE PORT VALVES SHALL BE TURNED OFF BEFORE ATTEMPTING INSTALLATION OF CRIMP ADAPTERS.

This connection is for when you need to convert a 3/8" compression port to 1/2" PEX using a crimp connection.



**CAUTION**  
Use only sealing elements supplied with the adapters.

1. Wet the sealing element (A) with tap water or silicone lubricant only. DO NOT USE Vaseline®, grease, oil, or any other lubricant. Use of petroleum-based lubricant can cause cracking of the plastic and result in a leak. Place the sealing element against the flange of the brass adapter (B) the end of the tubing.

Place the wet sealing element (A)...

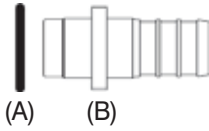

...against the brass adapter flange (B).

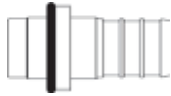

- Slide a crimp ring (C) - XLCR2 for 3/8" tubing; XLCR3 for 1/2" - and the supplied swivel nut (D) onto the tubing (threads of the nut toward the end of the tubing).

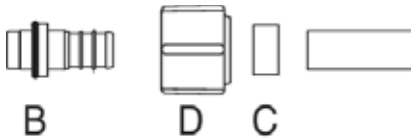

Insert the brass adapter (B) fully into the end of the tubing as shown.

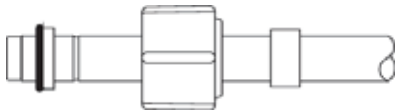

- Slide the swivel nut (D) back to brass adapter and slide the crimp ring (C) to within 1/8" to 1/4" from the end of tube. Crimp the ring with an appropriately sized full-circle crimp tool.

**DO NOT CRIMP TWICE.**

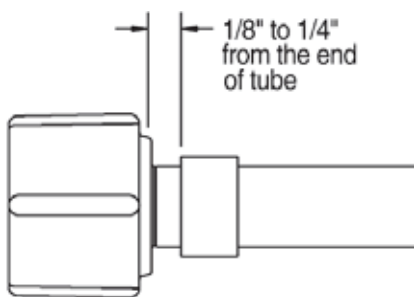

- With the sealing element still in place, thread the nut onto the MANABLOC port and tighten hand tight plus NO MORE THAN 1/8 turn additional.

### 6.3 Connecting Distribution

#### WATER CLOSET CONNECTIONS

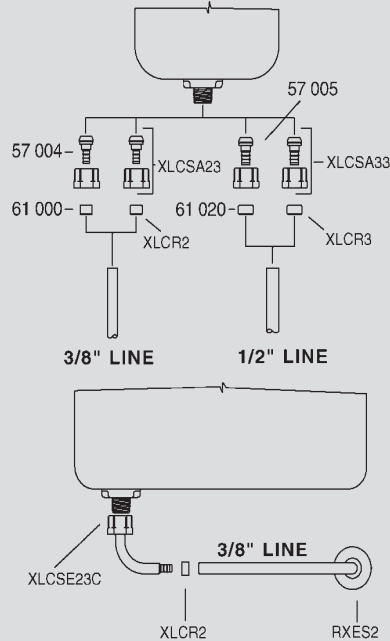

Tighten fixture nut hand tight plus an additional 1/4 turn. Check all connections for leaks.

**DO NOT OVERTIGHTEN.**

#### RISER CONNECTIONS

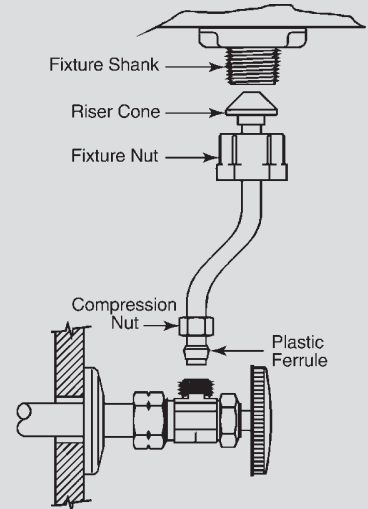

Thread fixture nut onto fixture shank. Tighten fixture nut hand tight plus an additional 1/2 turn. Slide compression nut and supplied plastic ferrule over tube as shown. The long taper of the ferrule goes towards valve. Tighten compression nut according to valve manufacturer's recommendations.

#### HOSE BIBB CONNECTIONS

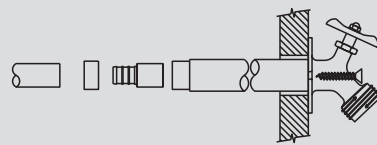

Hose bibbs supported by the structure can be connected directly.

Free standing hose bibbs shall not be supported by ViegaPEX.

Well-anchored drop-ear fittings or metal pipe shall be used to install hose bibbs.

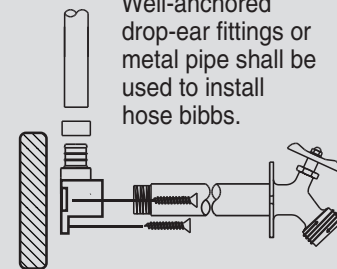

#### FAUCET CONNECTIONS LAV or KITCHEN

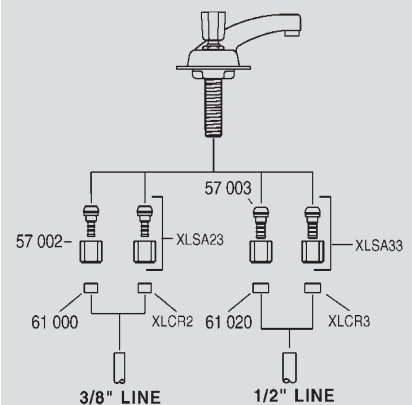

Tighten fixture nut hand tight plus an additional 1/4 turn. Check all connections for leaks.

**DO NOT OVERTIGHTEN.**

## 6.4 Water Supply Connections

The main water supply shall be turned off before making water supply connections.

The MANABLOC water supply connection uses a special 1" swivel MANABLOC transition fitting which seals with a rubber washer.

This connection is used on the cold water supply and the hot water supply/return lines. This connection to the MANABLOC does not require any form of thread sealant and none shall be used.

**DO NOT USE ANY FORM OF THREAD SEALANT TO MAKE THIS CONNECTION.**

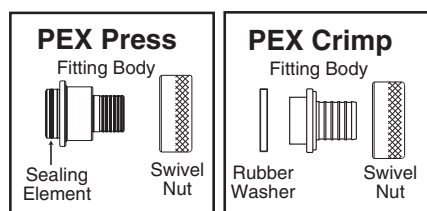

**NOTE:** Water Service connections to adapt to any type of plumbing supply materials are available. Consult the Viega Product Catalog for a complete listing of available connections.

1. Connect water service adapters to water supply piping before attaching the swivel fitting to the MANABLOC (instructions included with adapters.) Excessive force from threaded fittings, or solvents from solvent welding (PVC or CPVC) will cause damage to the MANABLOC.

Drill all holes in wood members for water supply/return tubing **BEFORE** mounting the MANABLOC.

2. When using male or female pipe thread transition fittings, use only Teflon® TAPE to seal pipe threads. **DO NOT** use pipe dopes, thread sealers, Teflon® pastes, etc.
3. If copper sweat fittings are used anywhere in the MANABLOC water

supply line or water heater supply/return lines, these fittings must be soldered, cooled, and flushed of any flux residue before these lines are connected to the MANABLOC.

Soldering creates a tremendous amount of heat which could melt the MANABLOC, and solder flux contains strong acids and may also contain petroleum products.

These compounds can attack the plastic materials from which the MANABLOC is made and cause crazing, cracking and failure of the MANABLOC, resulting in leaks and water damage.

4. Ensure that the hot/cold supply lines are connected to the correct supply inlet/outlet on the MANABLOC. Red valves designate hot ports, blue valves designate cold ports.
5. Supply lines shall enter and/or exit the MANABLOC in a straight line. If bending of the supply lines is required, the tubing must be anchored to a framing member to isolate the bend stress from the MANABLOC or use a directional fitting.
6. After the supply tubing has been connected to the transition fitting, place the rubber washer onto the swivel adapter, remove the plastic protective cap from the MANABLOC fitting and thread the swivel nut onto the threaded male adapter by hand. **DO NOT CROSS THREAD.**
7. Tightening the swivel connections on the inlet/outlet ports:
  - a. PEX Press, tighten the 1" swivel nut hand tight only.
  - b. PEX Crimp, tighten the 1" swivel nut hand-tight, then a quarter of a turn with channel locks. **DO NOT OVERTIGHTEN.** Excessive force could damage the MANABLOC. Repeat for all remaining supply line connections.

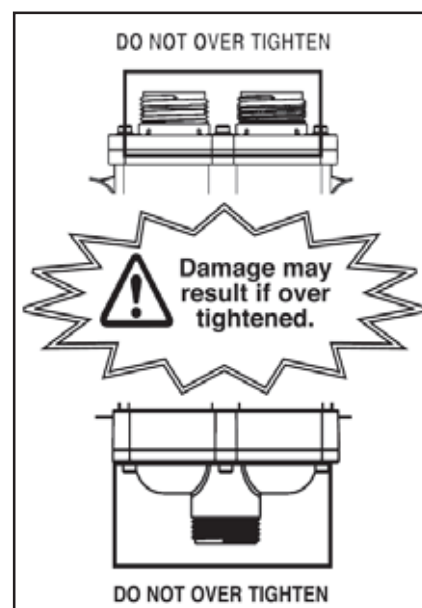
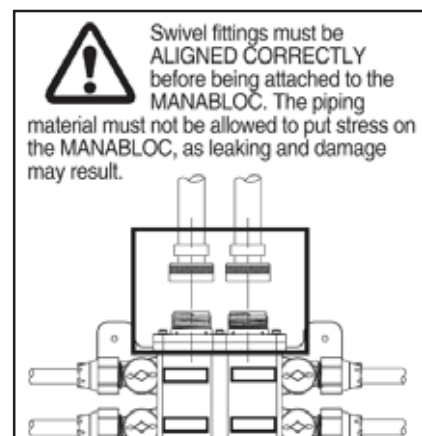
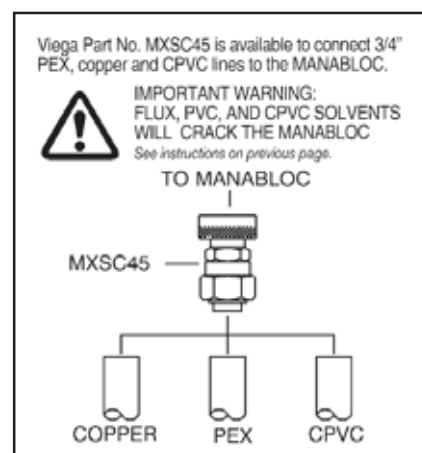

**DO NOT ELECTRICALLY GROUND TO THIS SYSTEM.**

## 7. FILLING AND TESTING

1. Upon completion of the installation, the system should be filled and hydrostatically tested. Use only POTABLE water for testing.



**WATER TESTING SHALL BE AVOIDED DURING FREEZING CONDITIONS.**

UNDER NO CIRCUMSTANCES SHALL THE SYSTEM BE TESTED AT TEMPERATURES LOWER THAN 10°F (-12°C).

2. Open all connected port valves before filling the system with water or air and pressurizing. If the MANABLOC is filled and pressurized before the port valves have been opened, read the following notice:



**NOTICE - VALVE INFORMATION!**

Opening a port valve to an empty or

unpressurized distribution line may cause valve damage.

To prevent potential valve damage or failure, open the port valves before filling and pressurizing the lines. The force of water rushing to fill an empty line can cause the valve's sealing to "clip off", resulting in incomplete sealing or complete valve failure.

CARE must be exercised when opening a port valve to an empty or unpressurized line. The fixture to which the line is connected should be in the OFF position and the valve must be opened slowly until water starts to flow into the line.

DO NOT CONTINUE to open the valve until the line is full and pressurized. Open the valve fully only after the line is up to system pressure. The fixture can then be opened to purge the line of air.

Valve stems are replaceable. Order Stock Code MBRS4.

3. Hydrostatic testing of the MANABLOC plumbing system is to be conducted according to local code requirements. In the absence of local codes, test pressure shall be at least the expected working pressure of the system, but not less than 40 psi nor greater than 225 psi.

NOTE: Some plumbing fixtures may not withstand test pressures greater than 80 psi. Consult fixture manufacturers instructions for pressure limitations or plug all distribution lines at the fixture end. The system shall, at a minimum, withstand the test pressure, without leaking, for a period of 15 minutes.



**WARNING! PRESSURES USED IN TESTING CAN BLOW UNMADE OR INCOMPLETE**

**CONNECTIONS APART WITH TREMENDOUS FORCE!**

This force is many times greater when air is used as a test medium. To reduce the risk of personal injury, ensure that all connections are completed before testing. Use only the pressure and time required to determine that the system is leak free.

4. Fluid testing the MANABLOC system at temperatures below freezing (less than 32°F, 0°C) may be performed using a solution of water and NON-TOXIC antifreeze such as propylene glycol (typically called RV antifreeze).

If such a solution is used, the antifreeze solution must be sufficiently concentrated to withstand the lowest temperature encountered while the testing fluid is in the system. Antifreeze solutions should be purged and the system flushed with potable water prior to consumer use.



The water heater shall be isolated and not included in the system air test.

5. Air pressure testing of a MANABLOC is acceptable and preferred to hydrostatic testing in areas where cold weather could freeze the system or where water is not available. MANABLOC valves shall be in the open position during the test, which shall utilize a pressure of not less than 40 psi and not greater than 100 psi. The system shall be tested for a minimum of 15 minutes but no longer than 1 hour. During the test, system pressure shall drop no more than 8 psi in the one hour period.

If the pressure in the system declines more than 8 psi during the minimum 15 minute period, repressurize the system to the original test pressure, and retest.\*

If the system pressure declines more than 8 psi again during the test period, test the distribution line test caps or any other fittings in the system with the approved leak detection solution. (Any connection found to be in question must be replaced or remade and the pressure test repeated.)

If the solution does not show a leak on any of the caps or fittings, isolate the MANABLOC by turning the valves to the "OFF" position, repressurize if needed, and apply the same solution to the MANABLOC manifold components.

For leak detection, use only a mixture of Original Palmolive Green™ dishwashing soap (#46100-46200) or Palmolive Ultra™ (#356140 or 46128) mixed with potable water at a ratio of 2 ounces of soap to one gallon of water (mix Ultra at a ratio of 1.5 ounces per gallon.)

\*During the initial test pressurization period, the system pressure indicated on the gauge may decrease due to the initial deformation of the pipe, followed

by slow expansion. The pressure drop is dependent on ambient temperature, system capacity, and test pressure but shall not be more than 8 psi in an hour.



Test shall be conducted when significant changes to temperature are not expected. Please note significant changes in ambient temperature also can affect system pressure.

6. Due to the normal contraction of the MANABLOC in extremely cold weather, the tie rods may appear loose. This is normal. DO NOT tamper with the tie rods, they are factory pre-set.



**DO NOT ALLOW FLUIDS TO FREEZE IN THE MANABLOC SYSTEM!**  
Fluids freezing in the MANABLOC will damage the unit.



**WATER (NOT ANTIFREEZE SOLUTION) MUST BE PURGED OR DRAINED FROM THE SYSTEM IF TEMPERATURES ARE EXPECTED TO FALL BELOW FREEZING (32°F, 0°C).**  
Low pressure compressed air can be used for purging.



**FOLLOW ANTIFREEZE MANUFACTURERS INSTRUCTIONS FOR CONCENTRATIONS. USE ONLY NON-TOXIC ANTIFREEZE APPROVED FOR USE IN DRINKING WATER SYSTEMS.**

## 8. SYSTEM DISINFECTION

### 8.1 General

Local codes may require system disinfection. When no other method is available, follow the time limitations and exposure levels show below

1. Use a chlorine solution and one of the exposure durations listed below:

Concentration	Period	Authority
200 PPM	3 hours	IPC/UPC®
50 PPM	24 hours	IPC/UPC®

2. Mix the disinfection solution thoroughly before adding it to the system.
3. The chlorine solution must reach all parts of the system. Open all fixtures (both sides) and flow water until a chlorine smell is present. As an alternative, chlorine test tablets can be used to detect chlorine at each fixture.
4. The chlorine source for the solution can be, but is not limited to, the following:

Chlorine Source	% Active Chlorine	Form	Amount Per 100 Gallon Water for a 200 PPM solution
Laundry bleach	5.25	Liquid	3 pints (48 oz.)

5. After the solution has been in the system for the time required by the Authority Having Jurisdiction or the exposure durations listed in step 1 above, the system shall be flushed completely with potable water.
6. The system must be purged or drained of all water or protected from freezing.

**FAILURE TO FLUSH THE SYSTEM NOTICE!**

To prevent reduced service life of system components, disinfection solutions shall not be allowed to stand in the system longer than 24 hours. Thoroughly flush the system with potable water after disinfection.



# Professional products, service and training for professional contractors



Rely on Viega for the most complete line of high tech/high quality plumbing, heating and snow melting systems available today... plus the most comprehensive customer field support in the industry.

Dedicated to education, Viega has been recognized by industry professionals as offering some of the most innovative, informative and interactive training courses. We have a comprehensive list of sessions in a variety of forms from half day workshops to rigorous three-day programs. Call to receive our complete course catalog.



## **ProPress® System**

Flameless  
copper joining  
technology.



## **ProPressG™ System**

Flameless  
copper fuel  
gas joining  
technology.



## **PureFlow® Systems**

Flexible  
PEX tubing  
plumbing  
technology.



## **ProRadiant Systems**

Comfortable,  
efficient heating  
technology.



## **S-no-Ice® System**

Snow and  
ice melting  
technology.



## **Viega LLC**

301 N. Main, Floor 9, Wichita, KS 67202  
Phone: 1-877-VIEGA-NA Fax: 1-800-976-9817  
[www.viega-na.com](http://www.viega-na.com) [service@viega.com](mailto:service@viega.com)