



USAIRE™



**GRILLES, REGISTERS,
DIFFUSERS,
DAMPERS &
LOUVERS**

Product Catalog

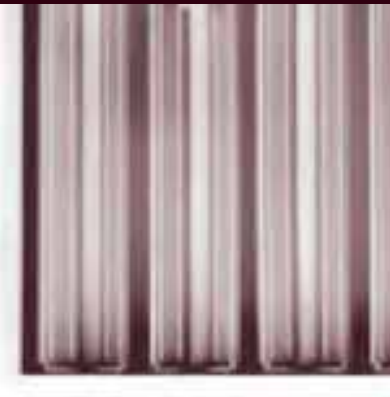
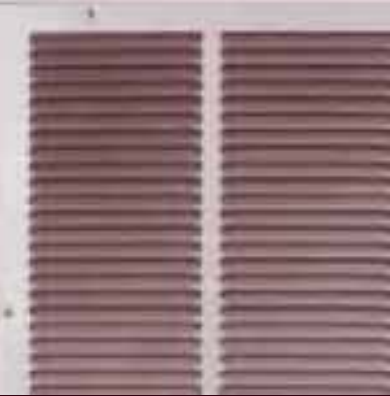

USAire • 1985 Carroll Street • Clearwater, Florida 33765

800-998-9929 toll free

800-965-8383 toll free fax

www.usaire.com

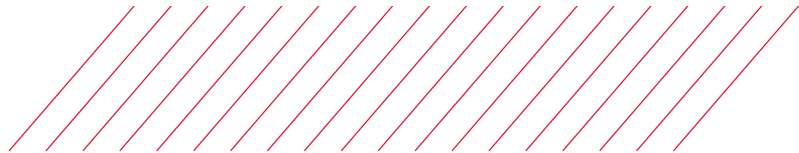
**RESIDENTIAL
GRILLES, REGISTERS AND DIFFUSERS**

Model	Description	Page
Ceiling / Sidewall Products		
101M	1 way Stamped Sidewall Supply	4
102M	2 way Stamped Sidewall Supply	4
103M	3 way Stamped Sidewall Supply	5
104M	4 way Stamped Sidewall Supply	5
201M	1 way Curved Blade Ceiling/Sidewall Supply	6
202M	2 way Curved Blade Ceiling/Sidewall Supply	6
203M	3 way Curved Blade Ceiling/Sidewall Supply	7
204M	4 way Curved Blade Ceiling/Sidewall Supply	7
1300	Baseboard Return Grille	8
1320	Toe Space Grille	8
1340	Baseboard Diffuser	9
1400	Return Air Grille	9
1410AD	Access Door	10
1410F	Return Air Filter Grille	10

Floor Products

1500	Floor Register - Face Only	11
1510D	Floor Register	11
1510DX	Floor Register w/ holes	12
1510X	Floor Register and Damper Box Only	12
1520M	Floor Register - Multi-Shutter Damper	12
1530	Bar Style Floor Grille	13
1530M	Bar Style Floor Register	13

Round and Square Ceiling Products

900/900S	Round Ceiling Diffuser	14
900D/900DS	Round Damper w/Ring	14
5200	Louver Face Ceiling Diffuser, Face Only	15
5200-D	Louver Face Ceiling Diffuser, w/Damper	15
5200-2C	Louver Face Ceiling Diffuser, Corner	16
5200D-2C	Louver Face Ceiling Diffuser, Corner, w/Damper	16

**COMMERCIAL
GRILLES, REGISTERS AND DIFFUSERS**

Model	Description	Page
Steel Sidewall / Ceiling Products		
4000SVM	Single Deflection Sidewall Supply	17
SRH	Fixed Bar Return Air Grille	17
SRHF	Fixed Bar Return Air Filter Grille	18

Aluminum Sidewall / Ceiling Products

V	Single Deflection Sidewall Supply - Grille Only	18
VD	Single Deflection Sidewall Supply, w/OBD	19
VM	Single Deflection Sidewall Supply, w/MS Damper	19
VH	Double Deflection Sidewall Supply, Grille Only	20
VHD	Double Deflection Sidewall Supply, w/OBD	20
L	1 way Curved Blade Ceiling Supply, Face Only	21
LT	2 way Curved Blade Ceiling Supply, Face Only	21
LS3	3 way Curved Blade Ceiling Supply, Face Only	22
LS4	4 way Curved Blade Ceiling Supply, Face Only	22
LTC	2 way Corner Curved Blade Ceiling Supply, Face Only	22
LTC3	3 way Corner Curved Blade Ceiling Supply, Face Only	22
LD	1 way Curved Blade Ceiling Supply, w/OBD	23
LTD	2 way Curved Blade Ceiling Supply, w/OBD	23
LTC3D	3 way Corner Curved Blade Ceiling Supply, w/OBD	24
LTC4D	4 way Curved Blade Ceiling Supply, w/OBD	24
LM	1 way Curved Blade Ceiling Supply, w/MS Damper	25
LTM	2 way Curved Blade Ceiling Supply, w/MS Damper	25
LS3M	3 way Curved Blade Ceiling Supply, w/MS Damper	26
LS4M	4 way Curved Blade Ceiling Supply, w/MS Damper	26
LMH	1 way Curved Blade Ceiling Supply, w/MS Damper, Border Handle	27
LTMH	2 way Curved Blade Ceiling Supply, w/MS Damper, Border Handle	27
RH	Fixed Bar Return Air Grille	28
RHD	Fixed Bar Return Air Grille, w/OBD	28
RHF	Fixed Bar Return Air Filter Grille	29

Extruded Aluminum Sidewall / Ceiling Products

H4002	Single Deflection Sidewall Supply, Grille Only, Horizontal	30
V4002	Single Deflection Sidewall Supply, Grille Only, Vertical	30
H4002D	Single Deflection Sidewall Supply, w/OBD, Horizontal	31
V4002D	Single Deflection Sidewall Supply, w/OBD, Vertical	31
H4002M	Single Deflection Sidewall Supply, w/MS Damper, Horizontal	32

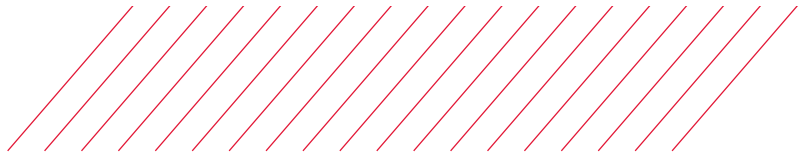

V4002M	Single Deflection Sidewall Supply, w/MS Damper, Vertical	32
H4004	Double Deflection Sidewall Supply, Grille Only, Horizontal	33
V4004	Double Deflection Sidewall Supply, Grille Only, Vertical	33
H4004D	Double Deflection Sidewall Supply, w/OBD, Horizontal	34
V4004D	Double Deflection Sidewall Supply, w/OBD, Vertical	34
RHE	Fixed Bar Return Air Grille	35
RHED	Fixed Bar Return Air Grille, w/OBD	35
RHEF	Fixed Bar Return Air Filter Grille	36

**Extruded Aluminum Ceiling Diffusers -
Cube Core, Mod Core / Louver**

CC5	Cube Core Return Air Grille	37
CC5D	Cube Core Return air Grille, w/OBD	37
CC5F	Cube Core Return Air Filter Grille	38
5500 DAF-CC5	Concentric Supply/Return Diffuser, Louver/Cube Core	39
9000	Mod Core Ceiling Diffuser	39
4900	Square/Rectangular Louver Face Ceiling Diffuser	40
4900D	Sq/Rectangular Louver Face Ceiling Diffuser w/OBD	40

Door Grilles / Transfer Grilles

DG	Transfer Door Grille	41
DGDF	Transfer Door Grille, w/Telescoping Frame (2) sides	41
DGSF	Transfer Door Grille, w/Partition Frame (1) side	42

Rounds and Spirals

3100A/3100SA	Commercial Round - Adjustable Core	43
3100/3100S	Commercial Round - Fixed Core	43
D3/SD3	Radial Opposed Blade Damper for 3100 Series	43
4004P	Spiral Pipe Grille, w/Scoop - Aluminum	44
4004SP	Spiral Pipe Grille, w/Scoop - Galvanized Steel	44

Linears and Slots

2000F	Linear Bar Floor Grille	45
2000FD	Linear Bar Floor Grille, w/OBD	45
6600	Linear Slot Diffuser	46
PHPR	Plenum Slot Return Diffuser	47
PHPS	Plenum Slot Supply Diffuser	47
PHPRI	Insulated Plenum Slot Return Diffuser	48
PHPSI	Insulated Plenum Slot Supply Diffuser	48

T-Bar Diffusers - Stamped/Bar Type/Cube Core

1410FTB	Return Air Filter Grille, T-Bar	49
----------------	---------------------------------	----

1410FTBI	Return Air Filter Grille, T-Bar, R-6 Molded Back	49
1420F	Return Air Filter Grille, T-Bar, Plenum Back	50
SRH-6	Fixed Bar Return Air Grille, T-Bar	50
SRHF-6	Fixed Bar Return Air Filter Grille, T-Bar	51
SRHFI-6	Fixed Bar Return Air Filter Grille, T-Bar, R-6 Molded Back	51
SRH20F	Fixed Bar Return Air Filter Grille, T-Bar, Plenum Back	52
RHTB	Fixed Bar Return Air Grille, T-Bar, Aluminum	52
RHFTB	Fixed Bar Return Air Filter Grille, T-Bar, Aluminum	53
RHFTBI	Fixed Bar Return Air Filter Grille, T-Bar, R-6 Molded Back, Aluminum	53
RH20F	Fixed Bar Return Air Filter Grille, T-Bar, Plenum Back, Aluminum	54
RHETB	Fixed Bar Return Air Grille, T-Bar, Ext. Alum.	54
RHEFTB	Fixed Bar Return Air Filter Grille, T-Bar, Ext. Alum.	55
RHEFTBI	Fixed Bar Return Air Filter Grille, T-Bar, R-6 Molded Back, Ext. Aluminum	55
CC5TB	Cube Core Return Air Grille, T-Bar	56
CC5DTB	Cube Core Return Air Grille, w/OBD, T-Bar	56
CC5FTB	Cube Core Return Air Filter Grille, T-Bar, Ext. Alum.	57
CC5FTBI	Cube Core Return Air Filter Grille, T-Bar, R-6 Molded Back, Ext. Aluminum	57
CC520F	Cube Core Return Air Filter Grille, T-Bar, Plenum Back, Ext. Aluminum	58
CC5CO	Cube Core Return Air Grille, Core Only, T-Bar, Ext. Alum.	58

T-Bar Diffusers - Louver Face

5200-6	Louver Face Ceiling Diffuser, T-Bar	59
5200-6D	Louver Face Ceiling Diffuser, w/OBD, T-Bar	59
5200-6 2C	Louver Face Ceiling Diffuser, Corner, T-Bar	60
5200-6D 2C	Louver Face Ceiling Diffuser, Corner, w/OBD, T-Bar	60

T-Bar Diffusers - Expanded/Perforated

7300-6	Expanded Metal Supply w/Round Disk, R6 Molded Back, T-Bar	61
7300R-6	Expanded Metal Return, R6 Molded Back, T-Bar	61
7305-6	Expanded Metal Supply w/Adjustable Deflectors, R6 Molded Back, T-Bar	62
SPRTB	Perforated Panel - Face Only, T-Bar	62
SPRFTB	Perforated Face Filter Grille, T-Bar	63
SPR20F	Perforated Face Filter Grille, T-Bar, Plenum Back	63
7500-6	Perforated Supply Diffuser, w/Pattern Deflectors, Removable Face, Steel Back, T-Bar	64
7500R-6	Perforated Return Diffuser, Removable Face, Steel Back, TBar	64
7550R-6	Perforated Return Diffuser, Removable Face, Sq Neck, Steel Back, T-Bar	65

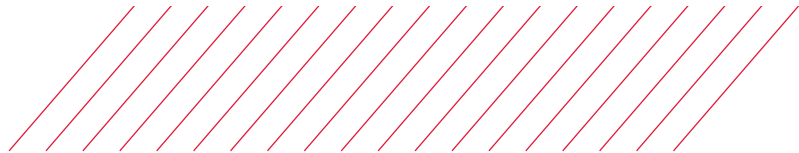

7600-6	Curved Blade Perforated Supply, Removable Face, Steel Back, T-Bar	66
7600R-6	Perforated Return, Removable Face, Steel Back, T-Bar	66

T-Bar Diffusers - Step Down / Plaque

4700-6	Step Down Ceiling Diffuser, 2 Cone, T-Bar	67
4700D-6	Step Down Ceiling Diffuser, 2 Cone, w/Damper, T-Bar	67
4706-6	Step Down Ceiling Diffuser, 2 Cone, w/R-6 Molded Back, T-Bar	68
4706D-6	Step Down Ceiling Diffuser, 2 Cone, w/R-6 Molded Back, w/Damper, T-Bar	68
4750-6	Plaque Panel Ceiling Diffuser, T-Bar	69
4750D-6	Plaque Panel Ceiling Diffuser, w/Damper, T-Bar	69
4756-6	Plaque Panel Ceiling Diffuser, w/R-6 Molded Back, T-Bar	70
4756D-6	Plaque Panel Ceiling Diffuser, w/R-6 Molded Back, w/Damper, T-Bar	70
4800-6	Step Down Ceiling Diffuser, 3 Cone, T-Bar	71
4800D-6	Step Down Ceiling Diffuser, 3 Cone, w/Damper, T-Bar	71
4806-6	Step Down Ceiling Diffuser, 3 Cone, w/R-6 Molded Back, T-Bar	72
4806D-6	Step Down Ceiling Diffuser, 3 Cone, w/R-6 Molded Back, w/Damper, T-Bar	72
5906-6	Step Down Ceiling Diffuser, 2 Cone, w/R-6 Molded Back, for Spin-in Collars, T-Bar	73
5906-3-6	Step Down Ceiling Diffuser, 3 Cone, w/R-6 Molded Back, T-Bar	73
5956-6	Plaque Panel Ceiling Diffuser, w/R-6 Molded Back, for Spin-in Collars, T-Bar	74

T-Bar Diffusers - Louvered / Mod Core / Concentric

4900-6	Square Louver Face Ceiling Diffuser, T-Bar, Aluminum	74
9000-6	Mod Core Ceiling Diffuser, T-Bar	75
5500SI-6	Louvered Face Ceiling Diffuser, w/R-6 Molded Back, for Spin-in Collars, T-Bar	75
5500 DAF-CC5-6	Concentric Supply/Return Diffuser, Louver Face - Cube Core, T-Bar	76

T-Bar Diffusers - Accessories

SNAP 59	Snap-in Collar, 1 1/2" high	77
SNAP 59-2	Snap-in Collar, 2" high	77
SNAP 58	Convert 2 Cone to 3 Cone	77
BDS	Round Butterfly Damper	78
RSD	Radial Shutter Damper	78
TBP/STBP	T-Bar Mounting Panel	78
TBPF/STBPF	Plaster Frame, T-Bar - Aluminum/Steel	79
PF	Plaster Frame - Ceiling/Sidewall	79
FGB-R6	R-6 Molded Fiberglass Back	79
OBD	Opposed Blade Damper, Steel	80

OBDA	Opposed Blade Damper, Aluminum	80
TR	Square to Round Transition, 1 1/8" Neck Height	81
TRD	Square to Round Transition, 1 7/8" Neck Height, 3" Deep Box	81

LOUVERS AND DAMPERS

Model	Description	Page
-------	-------------	------

Dampers

PBD-20 RS	Round Balancing Damper w/Locking Quadrant	85
PBD-20	Sq/Rect Balancing Damper w/Locking Quadrant	85
XABD-2	Backdraft Damper	86

Louvers

XAJ-4-GL	Stationary Louver, Straight Blade	87
XAD-4-45-GL	Stationary Louver, Drainable Blade	87

Fire Dampers

FD-A	1-1/2 Hour, Type A Static Fire Damper	88
FD-A-SL	1-1/2 Hour, Slimline Static Fire Damper	88
FD-B	1-1/2 Hour, Type B Static Fire Damper	89
FD-C	1-1/2 Hour, Type C Static Fire Damper	89
FD-A-S	1-1/2 Hour, Type A Static Fire Damper with Integral Sleeve	90
FD-B-S	1-1/2 Hour, Type B Static Fire Damper with Integral Sleeve	90
FD-C-S	1-1/2 Hour, Type C Static Fire Damper with Integral Sleeve and Transition	91
FDD-A	1-1/2 Hour, Type A Dynamic Fire Damper	92
FDD-A-SL	1-1/2 Hour, Slimline Dynamic Fire Damper	92
FDD-B	1-1/2 Hour, Type B Dynamic Fire Damper	93
FDD-C	1-1/2 Hour, Type C Dynamic Fire Damper	93
FDD-A-S	1-1/2 Hour, Type A Dynamic Fire Damper with Integral Sleeve	94
FDD-B-S	1-1/2 Hour, Type B Dynamic Fire Damper with Integral Sleeve	94
FDD-C-S	1-1/2 Hour, Type C Dynamic Fire Damper with Integral Sleeve and Transition	95

Ceiling Radiation Dampers

CD-RD-A	Ceiling Radiation Damper - Round (3-4 Hours)	96
CD-S/R-A	Ceiling Radiation Damper - Square/Rect. (3-4 Hours)	96
CD-S/R-HC	Wood Truss Ceiling Radiation Damper - Square/Rect. (1 Hour)	97

PERFORMANCE DATA

		98
--	--	----

INDEX

		117
--	--	-----



MODEL 101M

One Way Stamped Sidewall Supply STEEL

Performance data – page 98

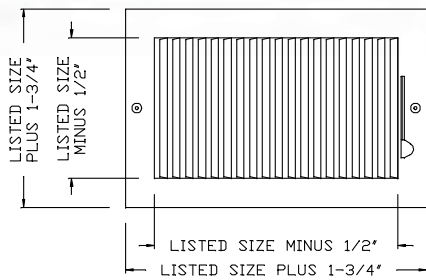

FEATURES

- Steel construction
- One way deflection
- 1/2" spacing lanced face
- Multi-shutter damper
- Riveted damper
- Steel handle operator
- Countersunk mounting holes
- 2" long zip screws
- White finish

Height	Width			
	8"	10"	12"	14"
4"	X			
6"		X	X	X

Other sizes available upon request

MODEL 102M

Two Way Stamped Sidewall Supply STEEL

Performance data – page 98

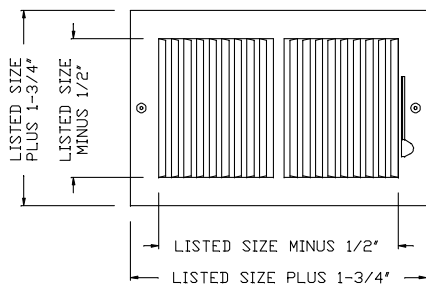

FEATURES

- Steel construction
- Two way deflection
- 1/2" spacing lanced face
- Multi-shutter damper
- Riveted damper
- Steel handle operator
- Countersunk mounting holes
- 2" long zip screws
- White finish

Height	Width					
	6"	8"	10"	12"	14"	16"
4"		X	X	X	X	
6"	X	X	X	X	X	X
8"		X	X	X	X	X

Other sizes available upon request

FEATURES

- Steel construction
- Three way deflection
- 1/2" spacing lanced face
- Multi-shutter damper
- Riveted damper
- Steel handle operator
- Countersunk mounting holes
- 2" long zip screws
- White finish

Height	Width					
	6"	8"	10"	12"	14"	16"
4"		X	X	X	X	
6"	X	X	X	X	X	X
8"		X	X	X	X	X
10"			X			
12"				X		
14"					X	

Other sizes available upon request

FEATURES

- Steel construction
- Four way deflection
- 1/2" spacing lanced face
- Multi-shutter damper
- Riveted damper
- Steel handle operator
- Countersunk mounting holes
- 2" long zip screws
- White finish

Height	Width				
	6"	8"	10"	12"	14"
6"	X				
8"		X			
10"			X		
12"				X	
14"					X

Other sizes available upon request

MODEL 103M
Three Way Stamped Sidewall Supply
STEEL

Performance data – page 98

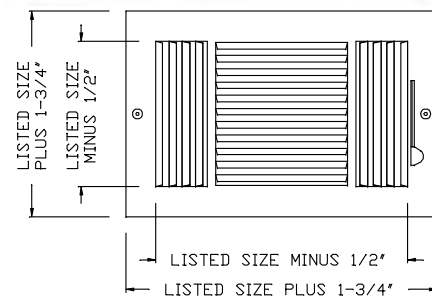
MODEL 104M
Four Way Stamped Sidewall Supply
STEEL

Performance data – page 98

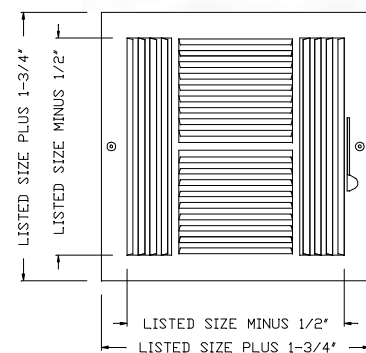



MODEL 201M

One Way Curved Blade Ceiling/Sidewall Supply STEEL

Performance data – page 99

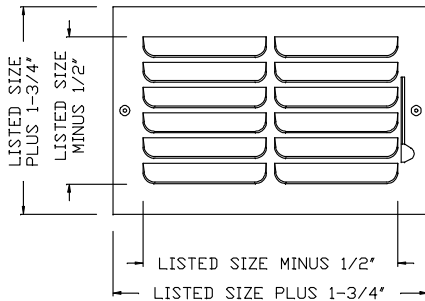

FEATURES

- Steel construction
- One way deflection
- Stamped curved blade face
- Multi-shutter damper
- Riveted damper
- Steel handle operator
- Countersunk mounting holes
- 2" long zip screws
- White finish

Height	Width				
	6"	8"	10"	12"	14"
4"		X	X		X
6"	X	X	X	X	X
8"			X	X	X
10"			X		
12"				X	

Other sizes available upon request

MODEL 202M

Two Way Curved Blade Ceiling/Sidewall Supply STEEL

Performance data – page 99

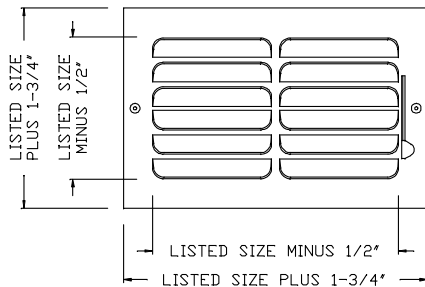

FEATURES

- Steel construction
- Two way deflection
- Stamped curved blade face
- Multi-shutter damper
- Riveted damper
- Steel handle operator
- Countersunk mounting holes
- 2" long zip screws
- White finish

Height	Width		
	10"	12"	14"
6"	X	X	X
8"	X	X	
10"	X		
12"		X	

Other sizes available upon request



FEATURES

- Steel construction
- Three way deflection
- Stamped curved blade face
- Multi-shutter damper
- Riveted damper
- Steel handle operator
- Countersunk mounting holes
- 2" long zip screws
- White finish

Height	Width				
	8"	10"	12"	14"	16"
4"	X	X			
6"	X	X	X	X	X
8"	X	X	X	X	
10"		X			
12"			X		
14"				X	

Other sizes available upon request

FEATURES

- Steel construction
- Four way deflection
- Stamped curved blade face
- Multi-shutter damper
- Riveted damper
- Steel handle operator
- Countersunk mounting holes
- 2" long zip screws
- White finish

Height	Width				
	6"	8"	10"	12"	14"
6"	X				
8"		X			
10"			X		
12"				X	
14"					X

Other sizes available upon request

MODEL 203M

Three Way Curved Blade Ceiling/Sidewall Supply

STEEL

Performance data – page 99

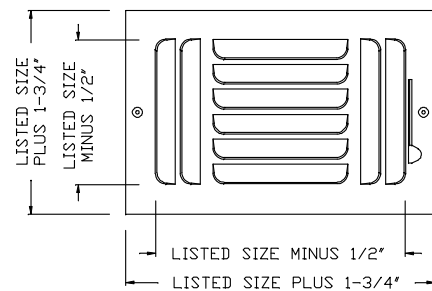

MODEL 204M

Four Way Curved Blade Ceiling/Sidewall Supply

STEEL

Performance data – page 99

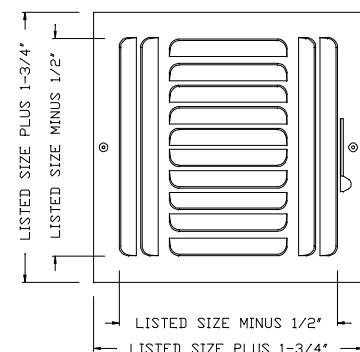



MODEL 1300

Baseboard Return Grille

STEEL

Performance data – page 98

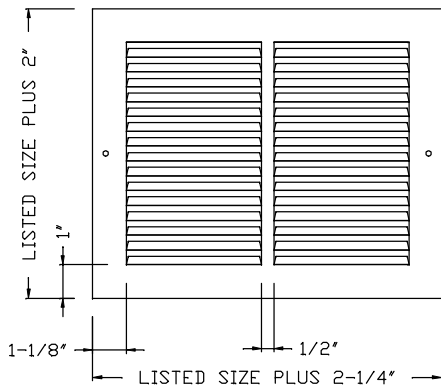

FEATURES

- Steel construction
- 1/2" stamped lanced face
- Fins set at 30 degree angle
- 7/8" turnback
- 2" long zip screws
- White finish

Height	Width									
	8"	10"	12"	14"	16"	18"	20"	24"	30"	36"
4"			X						X	
6"	X	X	X	X	X	X	X	X	X	X
8"		X	X	X	X	X	X	X	X	X
10"			X		X		X	X	X	X
12"		X			X		X	X	X	X
14"									X	

Other sizes available upon request

MODEL 1320

Toe Space Grille

STEEL

Performance data – page 98

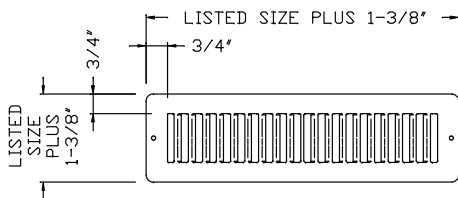

FEATURES

- Steel construction
- Stamped lanced face
- Multi-angle fins
- Includes screws
- White or brown finish

Height	Width		
	10"	12"	14"
2"	X	X	X

FEATURES

- Steel construction
- Fan shape air pattern
- Flap-style damper
- Removable face panel
- White or brown finish

ORDER AS MODEL 1340R RETURN (no damper)

Height	Width	
	15"	18"
4 1/2"	X	X

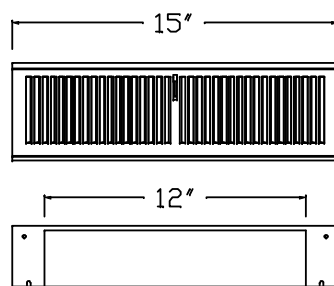
MODEL 1340
Baseboard Diffuser
STEEL

Performance data – page 99

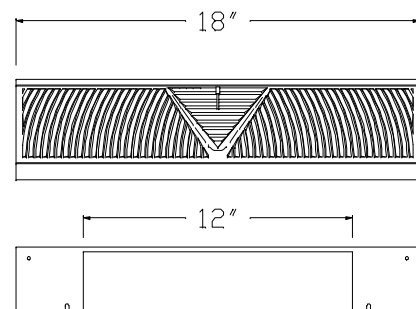

18" shown

FEATURES

- Steel construction
- 1/2" spaced louvers
- Fixed fins set at 50 degree angle
- White finish

Height	Width												
	6"	8"	10"	12"	14"	16"	18"	20"	22"	24"	25"	28"	30"
4"	X	X	X	X	X	X	X	X		X			X
6"	X	X	X	X	X	X	X	X		X			X
8"		X	X	X	X	X	X	X		X			X
10"			X	X	X	X	X	X		X			X
12"				X	X	X	X	X		X			X
14"		X	X		X	X	X	X		X	X	X	X
16"		X		X	X	X	X	X		X	X		X
18"				X	X		X	X		X	X		X
20"		X	X	X	X	X	X	X		X			X
24"		X	X	X	X	X	X	X	X	X			X
25"					X	X		X			X		
30"			X	X	X	X	X	X		X			X

Other sizes available upon request

MODEL 1400
Return Air Grille
STEEL

Performance data – page 100

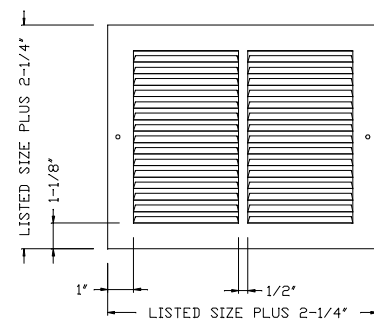



MODEL 1410AD

Access Door

STEEL

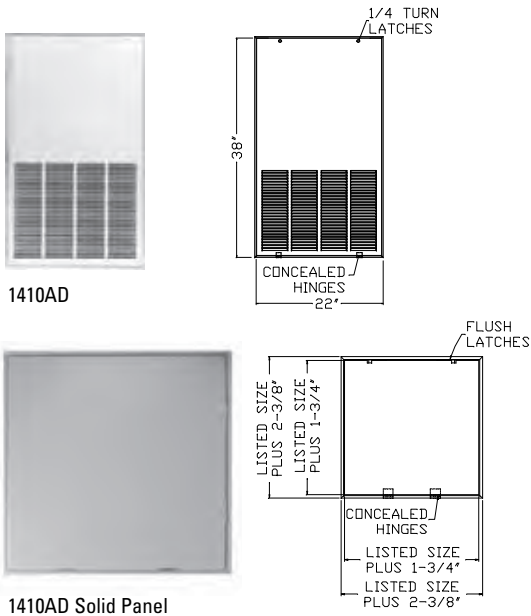

1410AD

1410AD Solid Panel

FEATURES

- Steel construction
- Model 1410AD Size 20" x 36" – Face panel is 1/2 stamped face and 1/2 solid panel.
- Quick-release panel permits easy access to equipment
- Designed for installation into 20" x 36" wall opening
- Model 1410AD Square Sizes – full solid panel
- White finish

Height	Width			
	12"	14"	20"	24"
12"	X			
14"		X		
24"				X
36"			X	

MODEL 1410F

Return Air Filter Grille

STEEL

Performance data – page 100

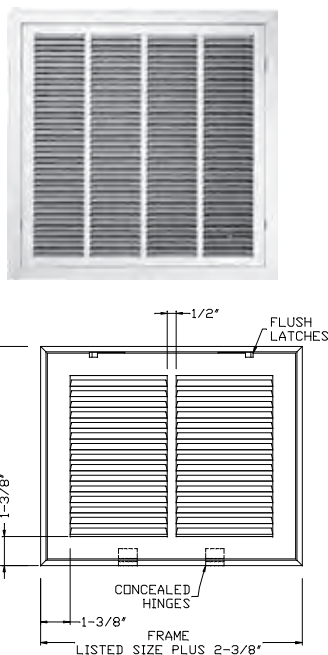

FEATURES

- Steel construction
- Stamped 1/2" lanced face
- Fins fixed at 50 degrees
- Removable face
- Flush latches
- Uses standard 1" filter (not included)
- White finish

Height	Width										
	8"	10"	12"	14"	16"	18"	20"	24"	25"	28"	30"
6"		X	X	X				X			X
8"	X		X	X	X		X	X			
10"		X			X		X	X			X
12"			X		X	X	X	X	X		X
14"				X	X	X	X	X	X	X	X
16"			X		X	X	X	X	X		X
18"			X	X		X	X	X	X		X
20"		X	X	X	X	X	X	X	X		X
24"		X	X	X	X	X	X	X			X
25"				X	X	X	X		X		
28"				X							
30"		X	X	X	X	X	X	X	X		X

Other sizes available upon request

Hinge bottom is standard when width is greater than height

Hinge side is standard when height is greater than width

Can be ordered as hinge bottom when height is greater than width – order as 1410F BH

FEATURES

- Steel construction
- Multi-angle fin setting
- Heavy-gauge rolled fins
- Face only for return application
- Holes in face to provide for screws
- White or brown finish

Height	Width		
	2"	4"	6"
8"		X	
10"	X	X	X
12"	X	X	X
14"	X	X	X

MODEL 1500
Floor Register – Face Only w/ Holes

STEEL

Performance data – page 101

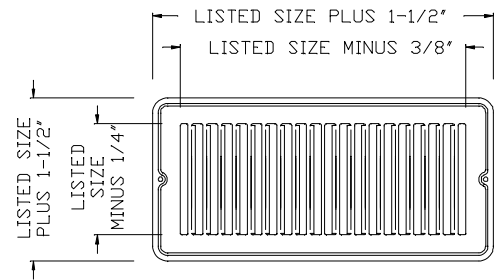
FEATURES

- Steel construction
- Multi-angle fin setting
- Heavy-gauge rolled fins
- Foot-operated dial control for damper operation
- White or brown finish

Height	Width		
	2"	4"	6"
8"		X	
10"	X	X	X
12"	X	X	X
14"	X	X	X

MODEL 1510D
Floor Register

STEEL

Performance data – page 101

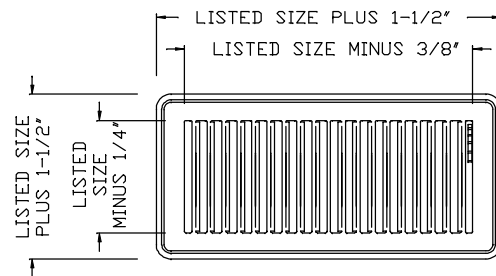



MODEL 1510DX/1510X

Floor Register w/ Holes

STEEL

Performance data – page 101

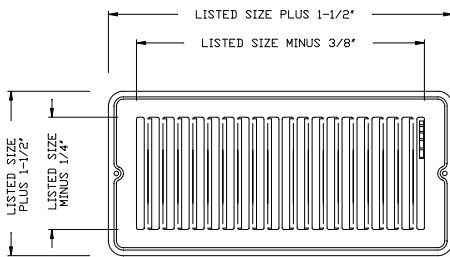

FEATURES

- Steel construction
- Model 1510DX – Floor register with holes
- Model 1510X – Face and damper box only
- Multi-angle fin setting
- Heavy-gauge rolled fins
- Foot-operated dial control for damper operation
- Mounting holes in face
- White or brown finish

Height	Width		
	2"	4"	6"
8"		X	
10"	X	X	X
12"	X	X	X
14"	X	X	X

MODEL 1520M

Floor Register – Multi-Shutter Damper

STEEL

Performance data – page 101

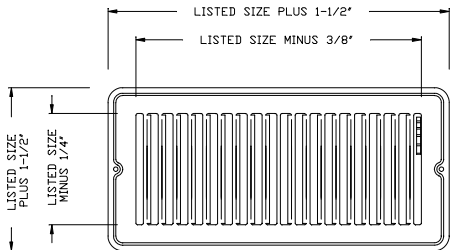

FEATURES

- Steel construction
- Multi-angle fin setting
- Mounting holes in face
- White or brown finish

Height	Width
	4"
8"	X
10"	X

FEATURES

- Steel construction
- Heavy gauge bar type construction
- Face bars interlock with crossbracing
- Smooth surface
- White or brown finish

Height	Width													
	4"	6"	8"	10"	12"	14"	16"	18"	20"	22"	24"	26"	28"	30"
6"		X												
8"	X	X	X											
10"	X	X	X	X										
12"	X	X	X	X	X									
14"	X	X	X	X	X	X								
16"	X	X	X	X	X	X	X							
18"	X	X	X	X	X	X	X	X						
20"	X	X	X	X	X	X	X	X	X					
22"	X		X	X	X	X	X	X	X	X				
24"	X	X	X	X	X	X	X	X	X	X	X			
26"	X	X	X	X	X	X	X	X	X	X	X	X		
28"	X	X	X		X	X	X	X	X	X	X	X	X	
30"	X	X	X	X	X	X	X	X	X	X	X	X	X	X

Other sizes available upon request

FEATURES

- Steel construction
- Heavy gauge bar type construction
- Face bars interlock with crossbracing
- Smooth surface
- Lever-operated dial control for damper operation
- White or brown finish

Height	Width						
	4"	6"	8"	10"	12"	14"	16"
6"	X	X					
8"	X	X	X				
10"	X	X	X	X			
12"	X	X	X	X	X		
14"	X	X	X	X	X	X	
16"		X	X			X	X
18"			X				
24"		X			X		

MODEL 1530
Bar Style Floor Grille

STEEL

Performance data – page 101

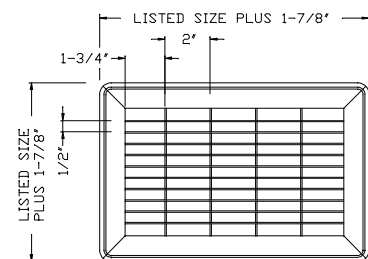
MODEL 1530M
Bar Style Floor Register

STEEL

Performance data – page 101

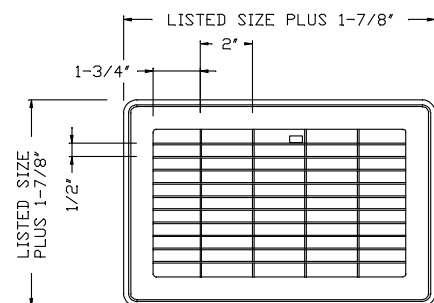



MODEL 900/900S

Round Ceiling Diffuser

ALUMINUM/STEEL

Performance data – page 105

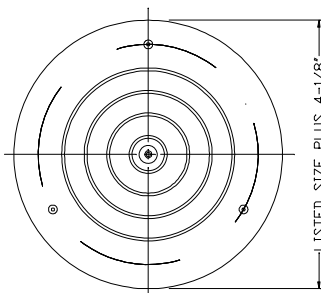

FEATURES

- Model 900 – Aluminum construction
- Model 900S – Steel construction
- 360 degree air pattern
- Concentric rings for even air distribution
- Mounting holes in outer ring
- Utilizes Model 900D damper (below)
- Hole in center core for damper control
- White finish

Diameter				
6"	8"	10"	12"	14"
X	X	X	X	X

MODEL 900D/900DS

Round Damper w/ Ring

ALUMINUM/STEEL

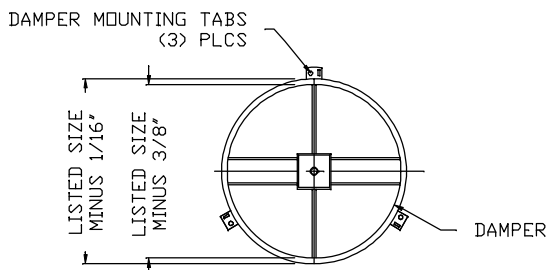

FEATURES

- Model 900D – Aluminum construction
- Model 900DS – Steel construction
- For use with Model 900 Round Diffuser
- Butterfly style damper
- Supplied with mounting hardware
- Includes damper operator
- Model 900D – Mill finish
- Model 900DS – Black finish

Diameter				
6"	8"	10"	12"	14"
X	X	X	X	X

FEATURES

5200-1 Flush Frame

5200-2 Bevel Frame

- All aluminum construction
- Face/frame only
- Removable core
- White finish
- Patterns: S1 – One Way S2 – Two Way
 S3 – Three Way S4 – Four Way

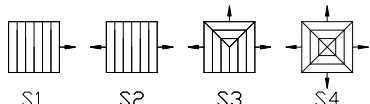

- For no screw holes on face, order as 5200 NSH

Height	Width						
	6"	8"	10"	12"	14"	16"	18"
6"	X						
8"		X					
10"			X				
12"				X			
14"					X		
16"						X	
18"							X

MODEL 5200

Louver Face Ceiling Diffuser – Face Only

ALUMINUM

Performance data – page 103

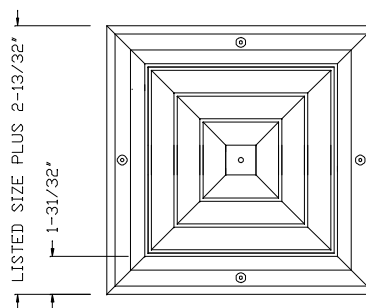

FEATURES

5200D-1 Flush Frame

5200D-2 Bevel Frame

- All aluminum construction
- Removable core
- Integral opposed blade damper
- Lever-operated damper control
- White finish
- Patterns: S1 – One Way S2 – Two Way
 S3 – Three Way S4 – Four Way

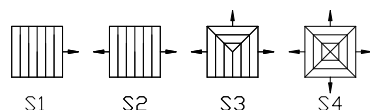

- For no screw holes on face, order as 5200D NSH

Height	Width						
	6"	8"	10"	12"	14"	16"	18"
6"	X						
8"		X					
10"			X				
12"				X			
14"					X		
16"						X	
18"							X

MODEL 5200-D

Louver Face Ceiling Diffuser – w/ Damper

ALUMINUM

Performance data – page 103

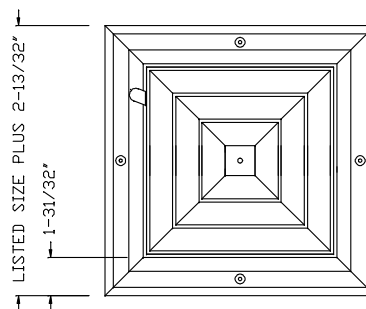



MODEL 5200-2C

**Louver Face Ceiling Diffuser
– Face Only Two Way Corner**

ALUMINUM

Performance data – page 103

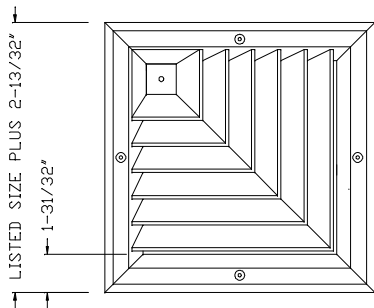

FEATURES

5200-2C-1 Flush Frame

5200-2C-2 Bevel Frame

- All aluminum construction
- Face/frame only
- Removable core
- White finish
- Pattern: 2C – Two Way Corner



2C

- For no screw holes on face, order as 5200-2C NSH

Height	Width						
	6"	8"	10"	12"	14"	16"	18"
6"	X						
8"		X					
10"			X				
12"				X			
14"					X		
16"						X	
18"							X

MODEL 5200D-2C

**Louver Face Ceiling Diffuser – w/Damper
Two Way Corner**

ALUMINUM

Performance data – page 103

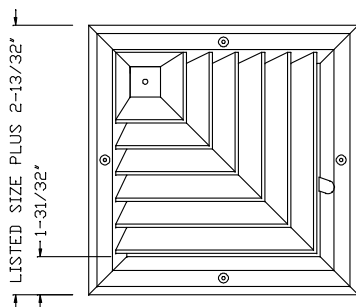

FEATURES

5200D-2C-1 Flush Frame

5200D-2C-2 Bevel Frame

- All aluminum construction
- Removable core
- Integral opposed blade damper
- Lever-operated damper control
- White finish
- Pattern: 2C – Two Way Corner



2C

- For no screw holes on face, order as 5200D-2C NSH

Height	Width						
	6"	8"	10"	12"	14"	16"	18"
6"	X						
8"		X					
10"			X				
12"				X			
14"					X		
16"						X	
18"							X

FEATURES

- Steel construction
- Adjustable vertical blades
- Blades spaced at 2/3" on center
- Multi-shutter damper
- Steel handle operator
- White finish

Height	Width								
	8"	10"	12"	14"	16"	18"	20"	24"	30"
4"	X	X	X	X	X				
6"	X	X	X	X	X		X	X	X
8"	X	X	X	X	X	X	X	X	
10"		X	X		X		X	X	
12"			X				X	X	
14"				X					

MODEL 4000SVM
Single Deflection Sidewall Supply
STEEL

Performance data – page 102

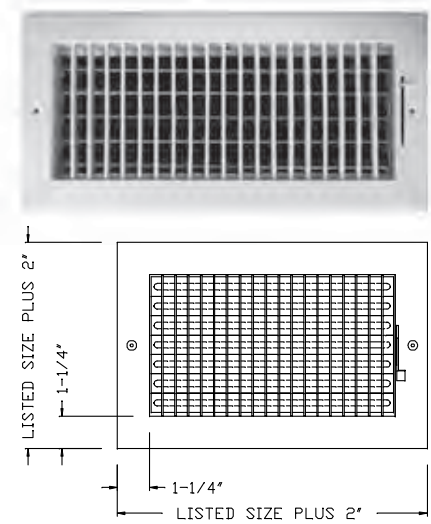
FEATURES

- Steel construction
- Fixed horizontal blades set at 45 degree angle
- Blades spaced at 2/3" on center
- White finish

Height	Width												
	6"	8"	10"	12"	14"	16"	18"	20"	22"	24"	26"	28"	30"
4"	X	X	X	X	X	X	X	X	X	X	X	X	X
5"	X	X	X	X	X	X	X	X	X	X	X	X	X
6"	X	X	X	X	X	X	X	X	X	X	X	X	X
8"		X	X	X	X	X	X	X	X	X	X	X	X
10"			X	X	X	X	X	X	X	X	X	X	X
12"				X	X	X	X	X	X	X	X	X	X
14"					X	X	X	X	X	X	X	X	X
16"						X	X	X	X	X	X	X	X
18"							X	X	X	X	X	X	X
20"								X	X	X	X	X	X
22"									X	X	X	X	X
24"										X	X	X	X
26"											X	X	X
28"												X	X
30"													X

Other sizes available upon request

MODEL SRH
Fixed Bar Return Air Grille
STEEL

Performance data – page 107

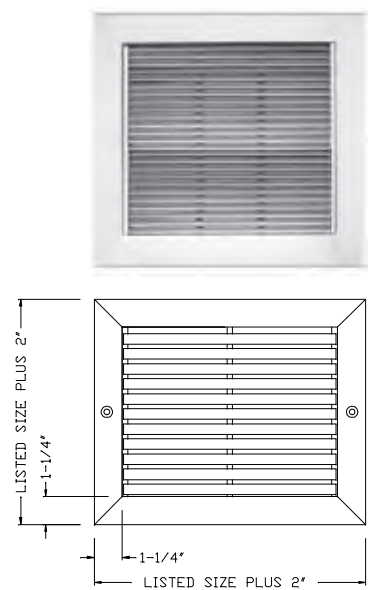



MODEL SRHF

Fixed Bar Return Air Filter Grille

STEEL

Performance data – page 107

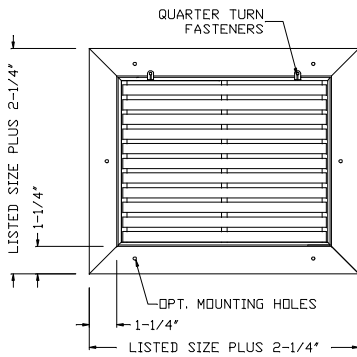

FEATURES

- Steel construction
- Fixed horizontal blades set at 45 degree angle
- Blades spaced at 2/3" on center
- Accepts disposable 1" filter (not included)
- Hinged face with 1/4 turn latches
- White finish

Height	Width												
	6"	8"	10"	12"	14"	16"	18"	20"	22"	24"	26"	28"	30"
4"	X	X	X	X	X	X	X	X	X	X	X	X	X
5"	X	X	X	X	X	X	X	X	X	X	X	X	X
6"	X	X	X	X	X	X	X	X	X	X	X	X	X
8"		X	X	X	X	X	X	X	X	X	X	X	X
10"			X	X	X	X	X	X	X	X	X	X	X
12"				X	X	X	X	X	X	X	X	X	X
14"					X	X	X	X	X	X	X	X	X
16"						X	X	X	X	X	X	X	X
18"							X	X	X	X	X	X	X
20"								X	X	X	X	X	X
22"									X	X	X	X	X
24"										X	X	X	X
26"											X	X	X
28"												X	X
30"													X

Other sizes available upon request

MODEL V

Single Deflection Sidewall Supply – Grille Only

ALUMINUM

Performance data – page 105

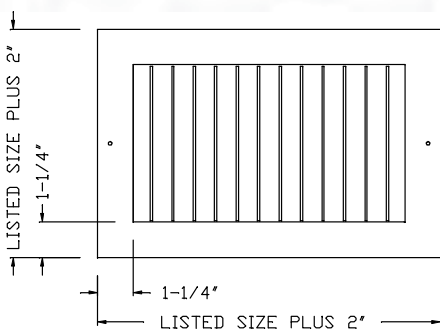

FEATURES

- Roll-formed aluminum construction
- Adjustable vertical blades
- Blades spaced at 2/3" on center
- White finish (optional aluminum finish)

Height	Width				
	6"	8"	10"	12"	14"
4"	X	X	X	X	X
6"	X	X	X	X	X
8"		X	X	X	X
10"			X		
12"				X	

Other sizes available upon request



FEATURES

- Roll-formed aluminum construction
- Adjustable vertical blades
- Blades spaced at 2/3" on center
- Integral opposed blade damper
- Damper controlled by screwdriver
- White finish (optional aluminum finish)

Height	Width				
	6"	8"	10"	12"	14"
4"	X	X	X	X	X
6"	X	X	X	X	X
8"		X	X	X	X
10"			X		
12"				X	

Other sizes available upon request

FEATURES

- Roll-formed aluminum construction
- Adjustable vertical blades
- Blades spaced at 2/3" on center
- Integral multi-shutter damper
- Damper controlled by lever
- White finish (optional aluminum finish)

Height	Width				
	6"	8"	10"	12"	14"
4"	X	X	X	X	X
6"	X	X	X	X	X
8"		X	X	X	X
10"			X		
12"				X	

Other sizes available upon request

MODEL VD

Single Deflection Sidewall Supply w/OBD
ALUMINUM

Performance data – page 105

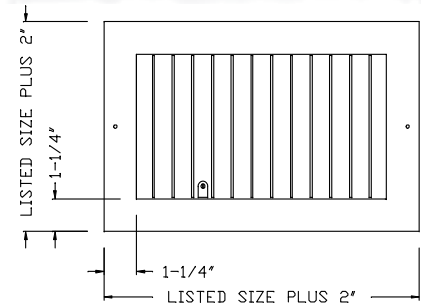
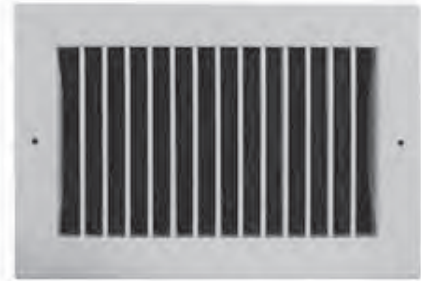

MODEL VM

Single Deflection Sidewall Supply w/MS Damper
ALUMINUM

Performance data – page 105

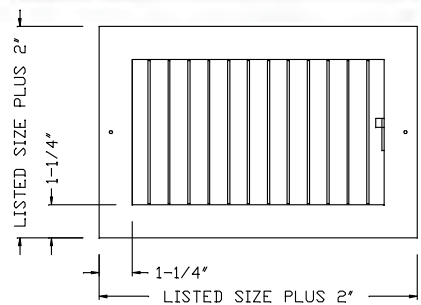
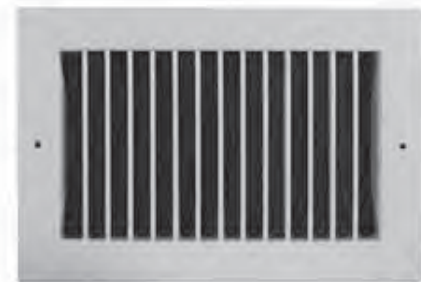

COMMERCIAL

GRILLES AND REGISTERS - ALUMINUM



MODEL VH

Double Deflection Sidewall Supply – Grille Only ALUMINUM

Performance data – page 105

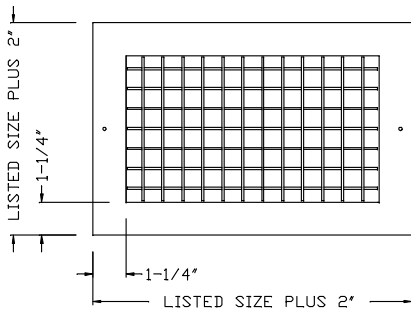
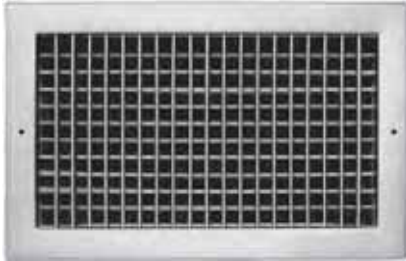

FEATURES

- Roll-formed aluminum construction
- Adjustable vertical blades in front
- Adjustable horizontal blades in back
- Blades spaced at 2/3" on center
- White finish (optional aluminum finish)

Height	Width				
	6"	8"	10"	12"	14"
4"	X	X	X	X	X
6"	X	X	X	X	X
8"		X	X	X	X
10"			X		
12"				X	

Other sizes available upon request

MODEL VHD

Double Deflection Sidewall Supply w/OBD ALUMINUM

Performance data – page 105

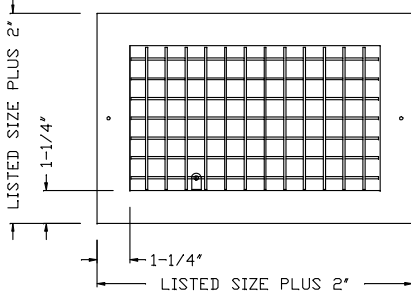
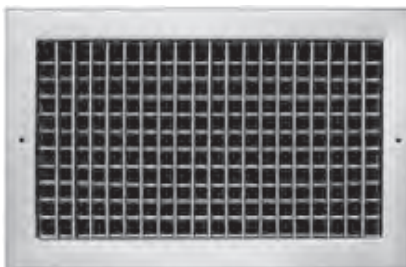

FEATURES

- Roll-formed aluminum construction
- Adjustable vertical blades in front
- Adjustable horizontal blades in back
- Blades spaced at 2/3" on center
- Integral opposed blade damper
- Damper is operated by screwdriver
- White finish (optional aluminum finish)

Height	Width				
	6"	8"	10"	12"	14"
4"	X	X	X	X	X
6"	X	X	X	X	X
8"		X	X	X	X
10"			X		
12"				X	

Other sizes available upon request

FEATURES

- Roll-formed aluminum construction
- Adjustable curved blades at 15/16" centers
- One way air pattern
- Grille only
- White finish (optional aluminum finish)

Height	Width												
	6"	8"	10"	12"	14"	16"	18"	20"	22"	24"	26"	28"	30"
4"	X	X	X	X	X	X	X	X	X	X	X	X	X
5"	X	X	X	X	X	X	X	X	X	X	X	X	X
6"	X	X	X	X	X	X	X	X	X	X	X	X	X
8"		X	X	X	X	X	X	X	X	X	X	X	X
10"			X	X	X	X	X	X	X	X	X	X	X
12"				X	X	X	X	X	X	X	X	X	X
14"					X	X	X	X	X	X	X	X	X
16"						X	X	X	X	X	X	X	X
18"							X	X	X	X	X	X	X
20"								X	X	X	X	X	X
22"									X	X	X	X	X
24"										X	X	X	X
26"											X	X	X
28"												X	X
30"													X

Other sizes available upon request

FEATURES

- Roll-formed aluminum construction
- Adjustable curved blades at 15/16" centers
- Two way air pattern
- Grille only
- White finish (optional aluminum finish)

Height	Width												
	6"	8"	10"	12"	14"	16"	18"	20"	22"	24"	26"	28"	30"
4"	X	X	X	X	X	X	X	X	X	X	X	X	X
5"	X	X	X	X	X	X	X	X	X	X	X	X	X
6"	X	X	X	X	X	X	X	X	X	X	X	X	X
8"		X	X	X	X	X	X	X	X	X	X	X	X
10"			X	X	X	X	X	X	X	X	X	X	X
12"				X	X	X	X	X	X	X	X	X	X
14"					X	X	X	X	X	X	X	X	X
16"						X	X	X	X	X	X	X	X
18"							X	X	X	X	X	X	X
20"								X	X	X	X	X	X
22"									X	X	X	X	X
24"										X	X	X	X
26"											X	X	X
28"												X	X
30"													X

Other sizes available upon request

MODEL L
Curved Blade Ceiling Supply Face Only – 1-Way
ALUMINUM

Performance data – page 104

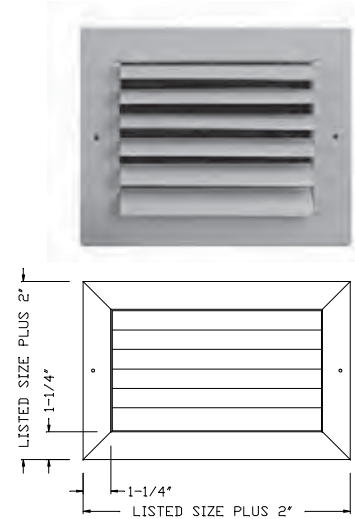
MODEL LT
Curved Blade Ceiling Supply Face Only – 2-Way
ALUMINUM

Performance data – page 104

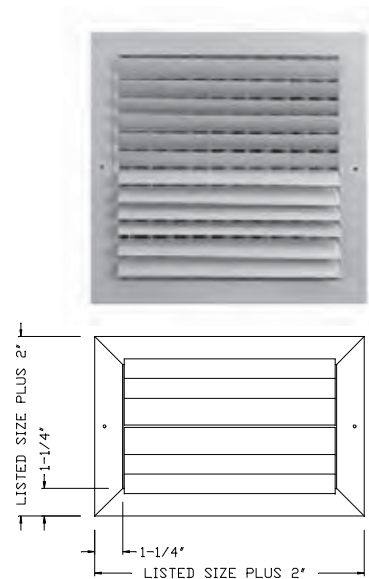



MODEL LS3/LS4

Curved Blade Ceiling Supply Face Only

LS3 – 3-Way

LS4 – 4-Way

ALUMINUM

Performance data – page 104

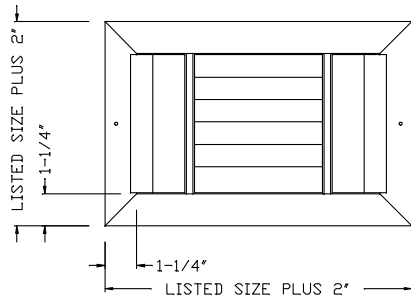

FEATURES

- Roll-formed aluminum construction
- Adjustable curved blades at 15/16" centers
- Three and four way air patterns
- Grille only
- White finish (optional aluminum finish)

Height	Width												
	6"	8"	10"	12"	14"	16"	18"	20"	22"	24"	26"	28"	30"
4"	X	X	X	X	X	X	X	X	X	X	X	X	X
5"	X	X	X	X	X	X	X	X	X	X	X	X	X
6"	X	X	X	X	X	X	X	X	X	X	X	X	X
8"		X	X	X	X	X	X	X	X	X	X	X	X
10"			X	X	X	X	X	X	X	X	X	X	X
12"				X	X	X	X	X	X	X	X	X	X
14"					X	X	X	X	X	X	X	X	X
16"						X	X	X	X	X	X	X	X
18"							X	X	X	X	X	X	X
20"								X	X	X	X	X	X
22"									X	X	X	X	X
24"										X	X	X	X
26"											X	X	X
28"												X	X
30"													X

Other sizes available upon request

FEATURES

- Roll-formed aluminum construction
- Adjustable curved blades at 15/16" centers
- Two and three way corner air patterns
- Grille only
- White finish (optional aluminum finish)

MODEL LTC/LTC3

Curved Blade Ceiling Supply Face Only

LTC – 2-Way Corner

LTC3 – 3-Way Corner

ALUMINUM

Performance data – page 104

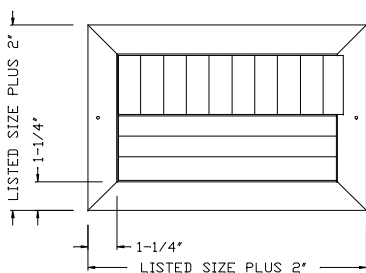

Height	Width												
	6"	8"	10"	12"	14"	16"	18"	20"	22"	24"	26"	28"	30"
4"	X	X	X	X	X	X	X	X	X	X	X	X	X
5"	X	X	X	X	X	X	X	X	X	X	X	X	X
6"	X	X	X	X	X	X	X	X	X	X	X	X	X
8"		X	X	X	X	X	X	X	X	X	X	X	X
10"			X	X	X	X	X	X	X	X	X	X	X
12"				X	X	X	X	X	X	X	X	X	X
14"					X	X	X	X	X	X	X	X	X
16"						X	X	X	X	X	X	X	X
18"							X	X	X	X	X	X	X
20"								X	X	X	X	X	X
22"									X	X	X	X	X
24"										X	X	X	X
26"											X	X	X
28"												X	X
30"													X

Other sizes available upon request

FEATURES

- Roll-formed aluminum construction
- Adjustable curved blades at 15/16" centers
- One way air pattern
- Includes opposed blade damper
- White finish (optional aluminum finish)

Height	Width												
	6"	8"	10"	12"	14"	16"	18"	20"	22"	24"	26"	28"	30"
4"	X	X	X	X	X	X	X	X	X	X	X	X	X
5"	X	X	X	X	X	X	X	X	X	X	X	X	X
6"	X	X	X	X	X	X	X	X	X	X	X	X	X
8"		X	X	X	X	X	X	X	X	X	X	X	X
10"			X	X	X	X	X	X	X	X	X	X	X
12"				X	X	X	X	X	X	X	X	X	X
14"					X	X	X	X	X	X	X	X	X
16"						X	X	X	X	X	X	X	X
18"							X	X	X	X	X	X	X
20"								X	X	X	X	X	X
22"									X	X	X	X	X
24"										X	X	X	X
26"											X	X	X
28"												X	X
30"													X

Other sizes available upon request

FEATURES

- Roll-formed aluminum construction
- Adjustable curved blades at 15/16" centers
- Two way air pattern
- Includes opposed blade damper
- White finish (optional aluminum finish)

Height	Width												
	6"	8"	10"	12"	14"	16"	18"	20"	22"	24"	26"	28"	30"
4"	X	X	X	X	X	X	X	X	X	X	X	X	X
5"	X	X	X	X	X	X	X	X	X	X	X	X	X
6"	X	X	X	X	X	X	X	X	X	X	X	X	X
8"		X	X	X	X	X	X	X	X	X	X	X	X
10"			X	X	X	X	X	X	X	X	X	X	X
12"				X	X	X	X	X	X	X	X	X	X
14"					X	X	X	X	X	X	X	X	X
16"						X	X	X	X	X	X	X	X
18"							X	X	X	X	X	X	X
20"								X	X	X	X	X	X
22"									X	X	X	X	X
24"										X	X	X	X
26"											X	X	X
28"												X	X
30"													X

Other sizes available upon request

MODEL LD
Curved Blade Ceiling Supply w/OBD – 1-Way
ALUMINUM

Performance data – page 104

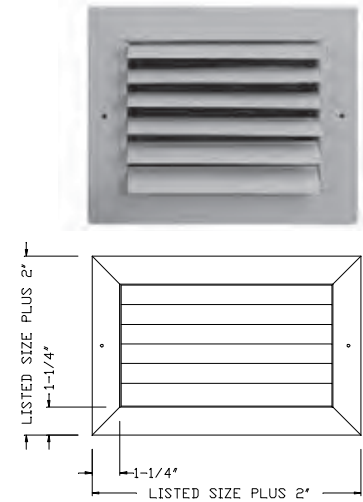
MODEL LTD
Curved Blade Ceiling Supply w/OBD – 2-Way
ALUMINUM

Performance data – page 104

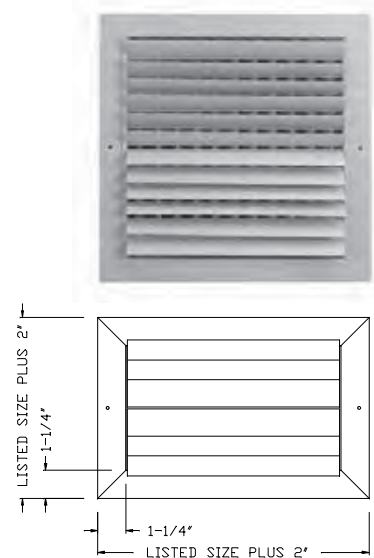



MODEL LTCD/LTC3D

Curved Blade Ceiling Supply w/OBD

LTCD – 2-Way Corner

LTC3D – 3-Way Corner

ALUMINUM

Performance data – page 104

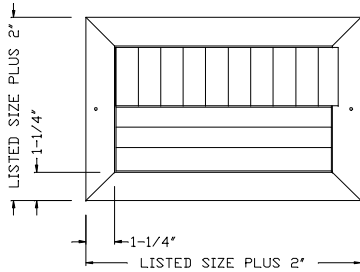

FEATURES

- Roll-formed aluminum construction
- Adjustable curved blades at 15/16" centers
- Two and three way corner air patterns
- Includes opposed blade damper
- White finish (optional aluminum finish)

Height	Width												
	6"	8"	10"	12"	14"	16"	18"	20"	22"	24"	26"	28"	30"
4"	X	X	X	X	X	X	X	X	X	X	X	X	X
5"	X	X	X	X	X	X	X	X	X	X	X	X	X
6"	X	X	X	X	X	X	X	X	X	X	X	X	X
8"		X	X	X	X	X	X	X	X	X	X	X	X
10"			X	X	X	X	X	X	X	X	X	X	X
12"				X	X	X	X	X	X	X	X	X	X
14"					X	X	X	X	X	X	X	X	X
16"						X	X	X	X	X	X	X	X
18"							X	X	X	X	X	X	X
20"								X	X	X	X	X	X
22"									X	X	X	X	X
24"										X	X	X	X
26"											X	X	X
28"												X	X
30"													X

Other sizes available upon request

COMMERCIAL

MODEL LS3D/LS4D

Curved Blade Ceiling Supply w/OBD

LS3D – 3-Way

LS4D – 4-Way

ALUMINUM

Performance data – page 104

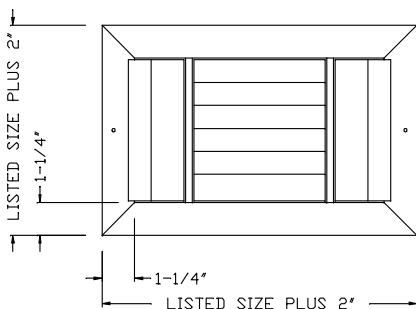

FEATURES

- Roll-formed aluminum construction
- Adjustable curved blades at 15/16" centers
- Three and Four way air patterns
- Includes opposed blade damper
- White finish (optional Aluminum finish)

Height	Width												
	6"	8"	10"	12"	14"	16"	18"	20"	22"	24"	26"	28"	30"
4"	X	X	X	X	X	X	X	X	X	X	X	X	X
5"	X	X	X	X	X	X	X	X	X	X	X	X	X
6"	X	X	X	X	X	X	X	X	X	X	X	X	X
8"		X	X	X	X	X	X	X	X	X	X	X	X
10"			X	X	X	X	X	X	X	X	X	X	X
12"				X	X	X	X	X	X	X	X	X	X
14"					X	X	X	X	X	X	X	X	X
16"						X	X	X	X	X	X	X	X
18"							X	X	X	X	X	X	X
20"								X	X	X	X	X	X
22"									X	X	X	X	X
24"										X	X	X	X
26"											X	X	X
28"												X	X
30"													X

Other sizes available upon request

GRILLES AND REGISTERS – ALUMINUM

FEATURES

- Roll-formed aluminum construction
- Adjustable curved blades at 15/16" centers
- One way air pattern
- Includes multi-shutter damper
- White finish (optional aluminum finish)

Height	Width									
	6"	8"	10"	12"	14"	16"	18"	20"	22"	24"
4"	X	X	X	X	X	X	X	X	X	X
5"	X	X	X	X	X	X	X	X	X	X
6"	X	X	X	X	X	X	X	X	X	X
8"		X	X	X	X	X	X	X	X	X
10"			X	X	X	X	X	X	X	X
12"				X	X	X	X	X	X	X
14"					X	X	X	X	X	X
16"						X	X	X	X	X
18"							X	X	X	X
20"								X	X	X
22"									X	X
24"										X

MODEL LM
Curved Blade Ceiling Supply w/MS Damper – 1-Way

ALUMINUM

Performance data – page 104

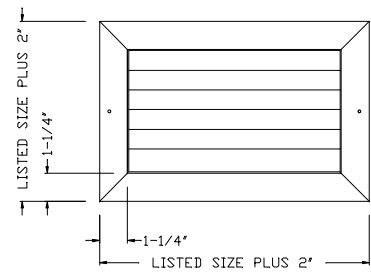
FEATURES

- Roll-formed aluminum construction
- Adjustable curved blades at 15/16" centers
- Two way air pattern
- Includes multi-shutter damper
- White finish (optional aluminum finish)

Height	Width									
	6"	8"	10"	12"	14"	16"	18"	20"	22"	24"
4"	X	X	X	X	X	X	X	X	X	X
5"	X	X	X	X	X	X	X	X	X	X
6"	X	X	X	X	X	X	X	X	X	X
8"		X	X	X	X	X	X	X	X	X
10"			X	X	X	X	X	X	X	X
12"				X	X	X	X	X	X	X
14"					X	X	X	X	X	X
16"						X	X	X	X	X
18"							X	X	X	X
20"								X	X	X
22"									X	X
24"										X

MODEL LTM
Curved Blade Ceiling Supply w/MS Damper – 2-Way

ALUMINUM

Performance data – page 104

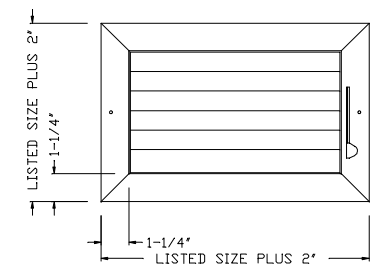



MODEL LS3M

**Curved Blade Ceiling Supply
w/MS Damper – 3-Way**

ALUMINUM

Performance data – page 104

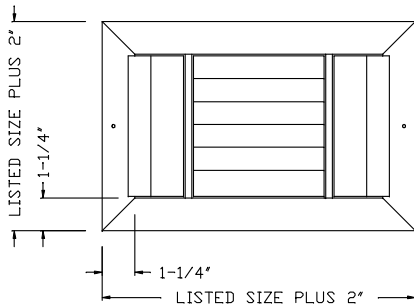

FEATURES

- Roll-formed aluminum construction
- Adjustable curved blades at 15/16" centers
- Three way air pattern
- Includes multi-shutter damper
- White finish (optional aluminum finish)

Height	Width									
	6"	8"	10"	12"	14"	16"	18"	20"	22"	24"
4"	X	X	X	X	X	X	X	X	X	X
5"	X	X	X	X	X	X	X	X	X	X
6"	X	X	X	X	X	X	X	X	X	X
8"		X	X	X	X	X	X	X	X	X
10"			X	X	X	X	X	X	X	X
12"				X	X	X	X	X	X	X
14"					X	X	X	X	X	X
16"						X	X	X	X	X
18"							X	X	X	X
20"								X	X	X
22"									X	X
24"										X

COMMERCIAL

MODEL LS4M

**Curved Blade Ceiling Supply
w/MS Damper – 4-Way**

ALUMINUM

Performance data – page 104

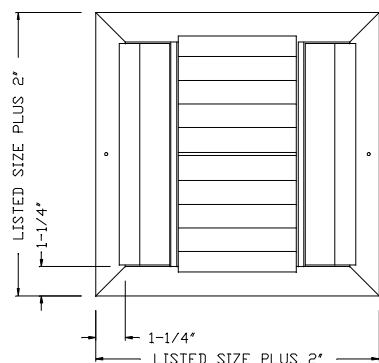

FEATURES

- Roll-formed aluminum construction
- Adjustable curved blades at 15/16" centers
- Four way air pattern
- Includes multi-shutter damper
- White finish (optional aluminum finish)

Height	Width				
	6"	8"	10"	12"	14"
6"	X				
8"		X			
10"			X		
12"				X	
14"					X

GRILLES AND REGISTERS – ALUMINUM



FEATURES

- Roll-formed aluminum construction
- Adjustable curved blades at 15/16" centers
- One way air pattern
- Includes multi-shutter damper
- Handle on outside of frame
- White finish (optional aluminum finish)

Height	Width				
	6"	8"	10"	12"	14"
4"	X	X	X	X	X
6"	X	X	X	X	X
8"		X	X	X	X
10"			X		
12"				X	

MODEL LMH

**Curved Blade Ceiling Supply w/MS Damper 1-Way,
Handle on Border**

ALUMINUM

Performance data – page 104

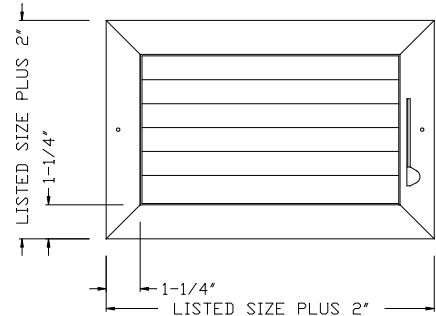

FEATURES

- Roll-formed aluminum construction
- Adjustable curved blades at 15/16" centers
- Two way air pattern
- Includes multi-shutter damper
- Handle on outside of frame
- White finish (optional aluminum finish)

Height	Width				
	6"	8"	10"	12"	14"
4"	X	X	X	X	X
6"	X	X	X	X	X
8"		X	X	X	X
10"			X		
12"				X	

MODEL LTMH

**Curved Blade Ceiling Supply w/MS Damper 2-Way,
Handle on Border**

ALUMINUM

Performance data – page 104

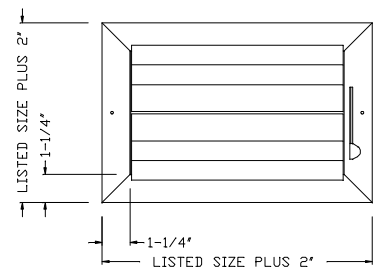

COMMERCIAL

CEILING GRILLES AND DIFFUSERS - ALUMINUM



MODEL RH

Fixed Bar Return Air Grille

ALUMINUM

Performance data – page 107

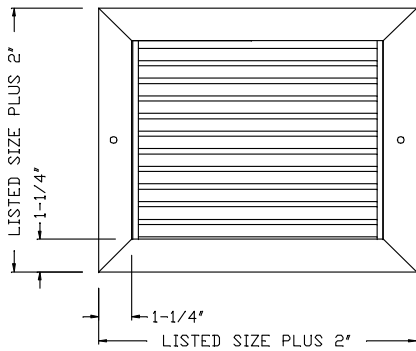

FEATURES

- Roll-formed aluminum construction
- Horizontal fixed blades at 45 degrees
- Blades spaced at 2/3" centers
- Grille only
- White finish (optional aluminum finish)

Height	Width												
	6"	8"	10"	12"	14"	16"	18"	20"	22"	24"	26"	28"	30"
4"	X	X	X	X	X	X	X	X	X	X	X	X	X
5"	X	X	X	X	X	X	X	X	X	X	X	X	X
6"	X	X	X	X	X	X	X	X	X	X	X	X	X
8"		X	X	X	X	X	X	X	X	X	X	X	X
10"			X	X	X	X	X	X	X	X	X	X	X
12"				X	X	X	X	X	X	X	X	X	X
14"					X	X	X	X	X	X	X	X	X
16"						X	X	X	X	X	X	X	X
18"							X	X	X	X	X	X	X
20"								X	X	X	X	X	X
22"									X	X	X	X	X
24"										X	X	X	X
26"											X	X	X
28"												X	X
30"													X

Other sizes available upon request

COMMERCIAL

MODEL RHD

Fixed Bar Return Air Grille w/OBD

ALUMINUM

Performance data – page 107

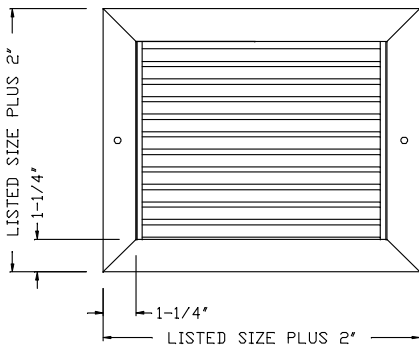

FEATURES

- Roll-formed aluminum construction
- Horizontal fixed blades at 45 degrees
- Blades spaced at 2/3" centers
- Includes opposed blade damper
- White finish (optional aluminum finish)

Height	Width												
	6"	8"	10"	12"	14"	16"	18"	20"	22"	24"	26"	28"	30"
4"	X	X	X	X	X	X	X	X	X	X	X	X	X
5"	X	X	X	X	X	X	X	X	X	X	X	X	X
6"	X	X	X	X	X	X	X	X	X	X	X	X	X
8"		X	X	X	X	X	X	X	X	X	X	X	X
10"			X	X	X	X	X	X	X	X	X	X	X
12"				X	X	X	X	X	X	X	X	X	X
14"					X	X	X	X	X	X	X	X	X
16"						X	X	X	X	X	X	X	X
18"							X	X	X	X	X	X	X
20"								X	X	X	X	X	X
22"									X	X	X	X	X
24"										X	X	X	X
26"											X	X	X
28"												X	X
30"													X

Other sizes available upon request

GRILLES AND REGISTERS – ALUMINUM



FEATURES

- Roll-formed aluminum construction
- Horizontal fixed blades at 45 degrees
- Blades are set at 2/3" centers
- Accepts 1" disposable filter (not included)
- Hinged face with 1/4 turn latches for easy access
- White finish (optional aluminum finish)

Height	Width												
	6"	8"	10"	12"	14"	16"	18"	20"	22"	24"	26"	28"	30"
4"	X	X	X	X	X	X	X	X	X	X	X	X	X
5"	X	X	X	X	X	X	X	X	X	X	X	X	X
6"	X	X	X	X	X	X	X	X	X	X	X	X	X
8"		X	X	X	X	X	X	X	X	X	X	X	X
10"			X	X	X	X	X	X	X	X	X	X	X
12"				X	X	X	X	X	X	X	X	X	X
14"					X	X	X	X	X	X	X	X	X
16"						X	X	X	X	X	X	X	X
18"							X	X	X	X	X	X	X
20"								X	X	X	X	X	X
22"									X	X	X	X	X
24"										X	X	X	X
26"											X	X	X
28"												X	X
30"													X

Other sizes available upon request

MODEL RHF
Fixed Bar Return Air Filter Grille
 ALUMINUM

Performance data – page 107

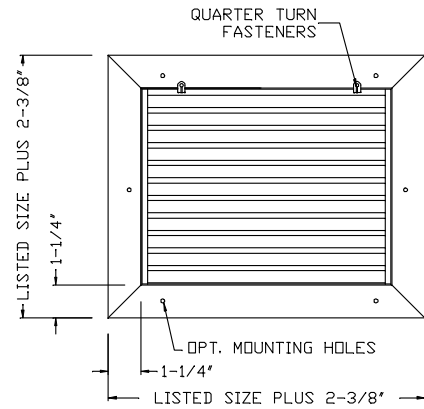

COMMERCIAL

GRILLES AND REGISTERS - ALUMINUM



MODEL H4002

Single Deflection Sidewall Supply Grille Only – Horizontal Blades

EXTRUDED ALUMINUM

Performance data – page 102

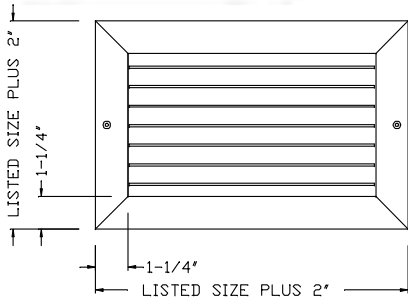

FEATURES

- Extruded aluminum construction
- Single deflection
- Adjustable horizontal blades
- Blades spaced at 2/3" centers
- Grille only
- White finish (optional aluminum finish)

Height	Width												
	6"	8"	10"	12"	14"	16"	18"	20"	22"	24"	26"	28"	30"
4"	X	X	X	X	X	X	X	X	X	X	X	X	X
5"	X	X	X	X	X	X	X	X	X	X	X	X	X
6"	X	X	X	X	X	X	X	X	X	X	X	X	X
8"		X	X	X	X	X	X	X	X	X	X	X	X
10"			X	X	X	X	X	X	X	X	X	X	X
12"				X	X	X	X	X	X	X	X	X	X
14"					X	X	X	X	X	X	X	X	X
16"						X	X	X	X	X	X	X	X
18"							X	X	X	X	X	X	X
20"								X	X	X	X	X	X
22"									X	X	X	X	X
24"										X	X	X	X
26"											X	X	X
28"												X	X
30"													X

Other sizes available upon request

COMMERCIAL

MODEL V4002

Single Deflection Sidewall Supply Grille Only – Vertical Blades

EXTRUDED ALUMINUM

Performance data – page 102

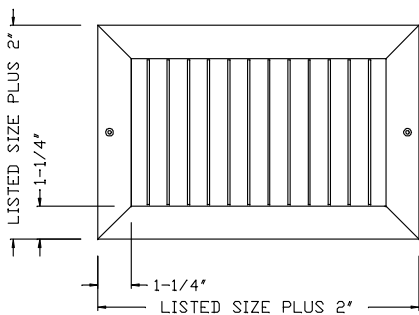
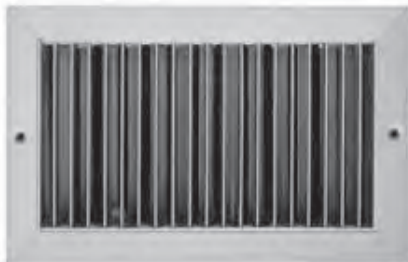

FEATURES

- Extruded aluminum construction
- Single deflection
- Adjustable vertical blades
- Blades spaced at 2/3" centers
- Grille only
- White finish (optional aluminum finish)

Height	Width												
	6"	8"	10"	12"	14"	16"	18"	20"	22"	24"	26"	28"	30"
4"	X	X	X	X	X	X	X	X	X	X	X	X	X
5"	X	X	X	X	X	X	X	X	X	X	X	X	X
6"	X	X	X	X	X	X	X	X	X	X	X	X	X
8"		X	X	X	X	X	X	X	X	X	X	X	X
10"			X	X	X	X	X	X	X	X	X	X	X
12"				X	X	X	X	X	X	X	X	X	X
14"					X	X	X	X	X	X	X	X	X
16"						X	X	X	X	X	X	X	X
18"							X	X	X	X	X	X	X
20"								X	X	X	X	X	X
22"									X	X	X	X	X
24"										X	X	X	X
26"											X	X	X
28"												X	X
30"													X

Other sizes available upon request

GRILLES AND REGISTERS – EXTRUDED ALUMINUM

FEATURES

- Extruded aluminum construction
- Single deflection
- Adjustable horizontal blades
- Blades spaced at 2/3" centers
- Includes opposed blade damper
- White finish (optional aluminum finish)

Height	Width												
	6"	8"	10"	12"	14"	16"	18"	20"	22"	24"	26"	28"	30"
4"	X	X	X	X	X	X	X	X	X	X	X	X	X
5"	X	X	X	X	X	X	X	X	X	X	X	X	X
6"	X	X	X	X	X	X	X	X	X	X	X	X	X
8"		X	X	X	X	X	X	X	X	X	X	X	X
10"			X	X	X	X	X	X	X	X	X	X	X
12"				X	X	X	X	X	X	X	X	X	X
14"					X	X	X	X	X	X	X	X	X
16"						X	X	X	X	X	X	X	X
18"							X	X	X	X	X	X	X
20"								X	X	X	X	X	X
22"									X	X	X	X	X
24"										X	X	X	X
26"											X	X	X
28"												X	X
30"													X

Other sizes available upon request

FEATURES

- Extruded aluminum construction
- Single deflection
- Adjustable vertical blades
- Blades spaced at 2/3" centers
- Includes opposed blade damper
- White finish (optional aluminum finish)

Height	Width												
	6"	8"	10"	12"	14"	16"	18"	20"	22"	24"	26"	28"	30"
4"	X	X	X	X	X	X	X	X	X	X	X	X	X
5"	X	X	X	X	X	X	X	X	X	X	X	X	X
6"	X	X	X	X	X	X	X	X	X	X	X	X	X
8"		X	X	X	X	X	X	X	X	X	X	X	X
10"			X	X	X	X	X	X	X	X	X	X	X
12"				X	X	X	X	X	X	X	X	X	X
14"					X	X	X	X	X	X	X	X	X
16"						X	X	X	X	X	X	X	X
18"							X	X	X	X	X	X	X
20"								X	X	X	X	X	X
22"									X	X	X	X	X
24"										X	X	X	X
26"											X	X	X
28"												X	X
30"													X

Other sizes available upon request

MODEL H4002D
Single Deflection Sidewall Supply w/OBD – Horizontal Blades

EXTRUDED ALUMINUM

Performance data – page 102

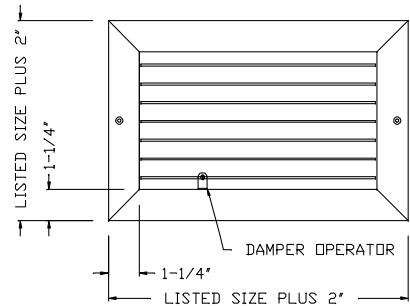
MODEL V4002D
Single Deflection Sidewall Supply w/OBD – Vertical Blades

EXTRUDED ALUMINUM

Performance data – page 102

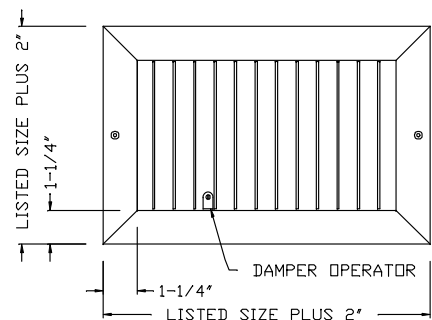



MODEL H4002M

**Single Deflection Sidewall Supply
w/MS Damper – Horizontal Blades**

EXTRUDED ALUMINUM

Performance data – page 102

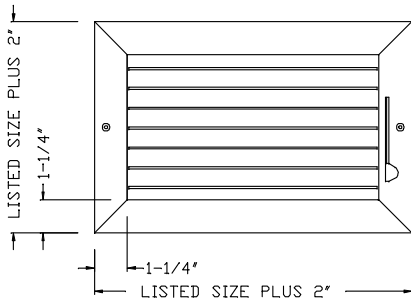
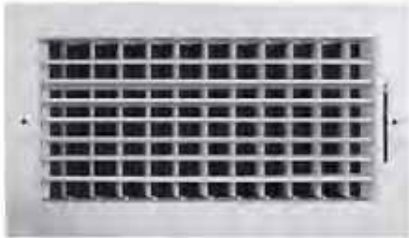

FEATURES

- Extruded aluminum construction
- Single deflection
- Adjustable horizontal blades
- Blades spaced at 2/3" centers
- Includes multi-shutter damper
- White finish (optional aluminum finish)

Height	Width									
	6"	8"	10"	12"	14"	16"	18"	20"	22"	24"
4"	X	X	X	X	X	X	X	X	X	X
5"	X	X	X	X	X	X	X	X	X	X
6"	X	X	X	X	X	X	X	X	X	X
8"		X	X	X	X	X	X	X	X	X
10"			X	X	X	X	X	X	X	X
12"				X	X	X	X	X	X	X
14"					X	X	X	X	X	X
16"						X	X	X	X	X
18"							X	X	X	X
20"								X	X	X
22"									X	X
24"										X

COMMERCIAL

MODEL V4002M

**Single Deflection Sidewall Supply
w/MS Damper – Vertical Blades**

EXTRUDED ALUMINUM

Performance data – page 102

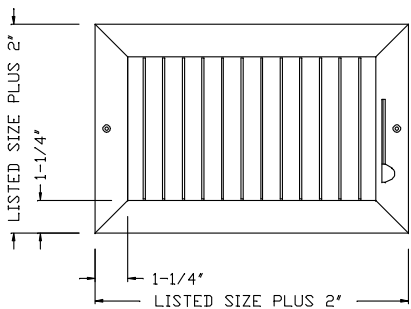
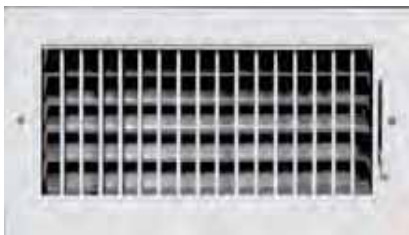

FEATURES

- Extruded aluminum construction
- Single deflection
- Adjustable vertical blades
- Blades spaced at 2/3" centers
- Includes multi-shutter damper
- White finish (optional aluminum finish)

Height	Width									
	6"	8"	10"	12"	14"	16"	18"	20"	22"	24"
4"	X	X	X	X	X	X	X	X	X	X
5"	X	X	X	X	X	X	X	X	X	X
6"	X	X	X	X	X	X	X	X	X	X
8"		X	X	X	X	X	X	X	X	X
10"			X	X	X	X	X	X	X	X
12"				X	X	X	X	X	X	X
14"					X	X	X	X	X	X
16"						X	X	X	X	X
18"							X	X	X	X
20"								X	X	X
22"									X	X
24"										X

GRILLES AND REGISTERS – EXTRUDED ALUMINUM

FEATURES

- Extruded aluminum construction
- Double deflection
- Adjustable horizontal front blades
- Adjustable vertical back blades
- Blades spaced at 2/3" centers
- Grille only
- White finish (optional aluminum finish)

Height	Width												
	6"	8"	10"	12"	14"	16"	18"	20"	22"	24"	26"	28"	30"
4"	X	X	X	X	X	X	X	X	X	X	X	X	X
5"	X	X	X	X	X	X	X	X	X	X	X	X	X
6"	X	X	X	X	X	X	X	X	X	X	X	X	X
8"		X	X	X	X	X	X	X	X	X	X	X	X
10"			X	X	X	X	X	X	X	X	X	X	X
12"				X	X	X	X	X	X	X	X	X	X
14"					X	X	X	X	X	X	X	X	X
16"						X	X	X	X	X	X	X	X
18"							X	X	X	X	X	X	X
20"								X	X	X	X	X	X
22"									X	X	X	X	X
24"										X	X	X	X
26"											X	X	X
28"												X	X
30"													X

Other sizes available upon request

FEATURES

- Extruded aluminum construction
- Double deflection
- Adjustable vertical front blades
- Adjustable horizontal back blades
- Blades spaced at 2/3" centers
- Grille only
- White finish (optional aluminum finish)

Height	Width												
	6"	8"	10"	12"	14"	16"	18"	20"	22"	24"	26"	28"	30"
4"	X	X	X	X	X	X	X	X	X	X	X	X	X
5"	X	X	X	X	X	X	X	X	X	X	X	X	X
6"	X	X	X	X	X	X	X	X	X	X	X	X	X
8"		X	X	X	X	X	X	X	X	X	X	X	X
10"			X	X	X	X	X	X	X	X	X	X	X
12"				X	X	X	X	X	X	X	X	X	X
14"					X	X	X	X	X	X	X	X	X
16"						X	X	X	X	X	X	X	X
18"							X	X	X	X	X	X	X
20"								X	X	X	X	X	X
22"									X	X	X	X	X
24"										X	X	X	X
26"											X	X	X
28"												X	X
30"													X

Other sizes available upon request

MODEL H4004
Double Deflection Sidewall Supply Grille Only – Horizontal Blades

EXTRUDED ALUMINUM

Performance data – page 102

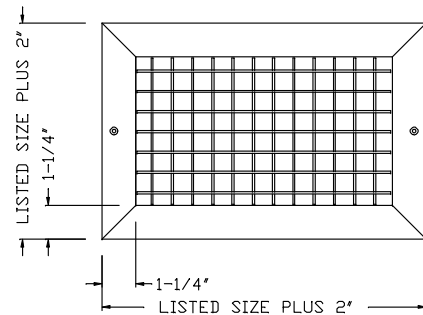
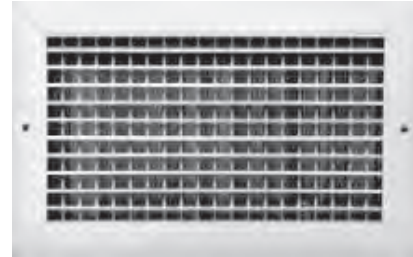
MODEL V4004
Double Deflection Sidewall Supply Grille Only – Vertical Blades

EXTRUDED ALUMINUM

Performance data – page 102

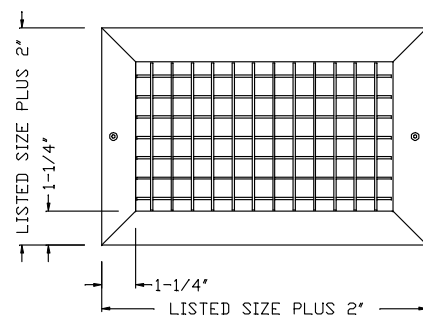
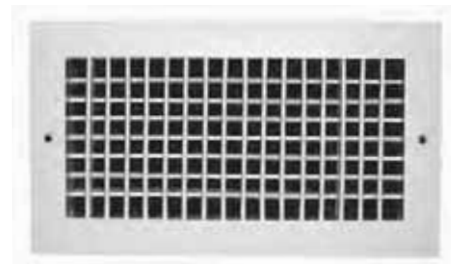



MODEL H4004D

Double Deflection Sidewall Supply w/OBD – Horizontal Blades

EXTRUDED ALUMINUM

Performance data – page 102

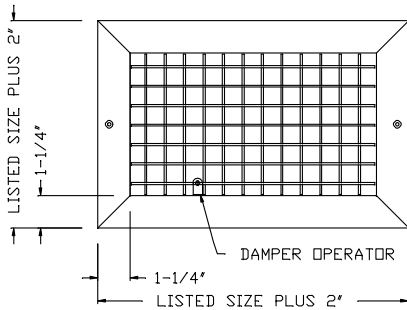

FEATURES

- Extruded aluminum construction
- Double deflection
- Adjustable horizontal front blades
- Adjustable vertical back blades
- Blades spaced at 2/3" centers
- Includes opposed blade damper
- White finish (optional aluminum finish)

Height	Width												
	6"	8"	10"	12"	14"	16"	18"	20"	22"	24"	26"	28"	30"
4"	X	X	X	X	X	X	X	X	X	X	X	X	X
5"	X	X	X	X	X	X	X	X	X	X	X	X	X
6"	X	X	X	X	X	X	X	X	X	X	X	X	X
8"		X	X	X	X	X	X	X	X	X	X	X	X
10"			X	X	X	X	X	X	X	X	X	X	X
12"				X	X	X	X	X	X	X	X	X	X
14"					X	X	X	X	X	X	X	X	X
16"						X	X	X	X	X	X	X	X
18"							X	X	X	X	X	X	X
20"								X	X	X	X	X	X
22"									X	X	X	X	X
24"										X	X	X	X
26"											X	X	X
28"												X	X
30"													X

Other sizes available upon request

COMMERCIAL

MODEL V4004D

Double Deflection Sidewall Supply w/OBD – Vertical Blades

EXTRUDED ALUMINUM

Performance data – page 102

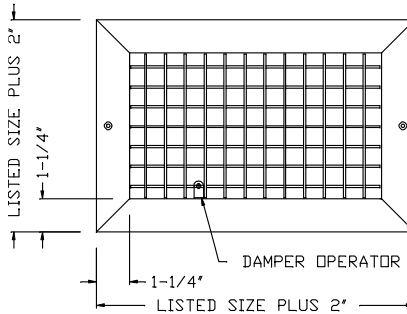
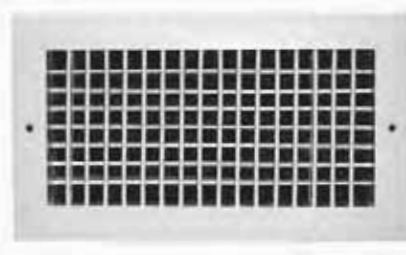

FEATURES

- Extruded aluminum construction
- Double deflection
- Adjustable vertical front blades
- Adjustable horizontal back blades
- Blades spaced at 2/3" centers
- Includes opposed blade damper
- White finish (optional aluminum finish)

Height	Width												
	6"	8"	10"	12"	14"	16"	18"	20"	22"	24"	26"	28"	30"
4"	X	X	X	X	X	X	X	X	X	X	X	X	X
5"	X	X	X	X	X	X	X	X	X	X	X	X	X
6"	X	X	X	X	X	X	X	X	X	X	X	X	X
8"		X	X	X	X	X	X	X	X	X	X	X	X
10"			X	X	X	X	X	X	X	X	X	X	X
12"				X	X	X	X	X	X	X	X	X	X
14"					X	X	X	X	X	X	X	X	X
16"						X	X	X	X	X	X	X	X
18"							X	X	X	X	X	X	X
20"								X	X	X	X	X	X
22"									X	X	X	X	X
24"										X	X	X	X
26"											X	X	X
28"												X	X
30"													X

Other sizes available upon request

GRILLES AND REGISTERS – EXTRUDED ALUMINUM

FEATURES

- Extruded aluminum construction
- Fixed horizontal blades set at 45 degrees
- Blades spaced at 2/3" centers
- Grille only
- White finish

Height	Width												
	6"	8"	10"	12"	14"	16"	18"	20"	22"	24"	26"	28"	30"
4"	X	X	X	X	X	X	X	X	X	X	X	X	X
5"	X	X	X	X	X	X	X	X	X	X	X	X	X
6"	X	X	X	X	X	X	X	X	X	X	X	X	X
8"		X	X	X	X	X	X	X	X	X	X	X	X
10"			X	X	X	X	X	X	X	X	X	X	X
12"				X	X	X	X	X	X	X	X	X	X
14"					X	X	X	X	X	X	X	X	X
16"						X	X	X	X	X	X	X	X
18"							X	X	X	X	X	X	X
20"								X	X	X	X	X	X
22"									X	X	X	X	X
24"										X	X	X	X
26"											X	X	X
28"												X	X
30"													X

Other sizes available upon request

FEATURES

- Extruded aluminum construction
- Fixed horizontal blades set at 45 degrees
- Blades spaced at 2/3" centers
- Includes opposed blade damper
- White finish

Height	Width												
	6"	8"	10"	12"	14"	16"	18"	20"	22"	24"	26"	28"	30"
4"	X	X	X	X	X	X	X	X	X	X	X	X	X
5"	X	X	X	X	X	X	X	X	X	X	X	X	X
6"	X	X	X	X	X	X	X	X	X	X	X	X	X
8"		X	X	X	X	X	X	X	X	X	X	X	X
10"			X	X	X	X	X	X	X	X	X	X	X
12"				X	X	X	X	X	X	X	X	X	X
14"					X	X	X	X	X	X	X	X	X
16"						X	X	X	X	X	X	X	X
18"							X	X	X	X	X	X	X
20"								X	X	X	X	X	X
22"									X	X	X	X	X
24"										X	X	X	X
26"											X	X	X
28"												X	X
30"													X

Other sizes available upon request

MODEL RHE
Fixed Bar Return Air Grille
 EXTRUDED ALUMINUM

Performance data – page 107

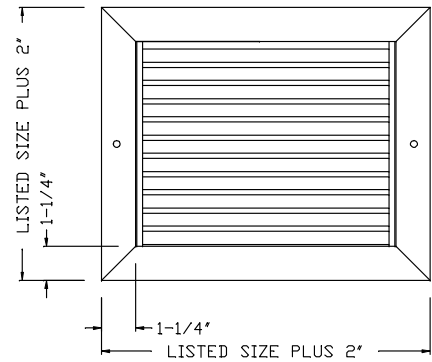
MODEL RHED
Fixed Bar Return Air Grille w/OBD
 EXTRUDED ALUMINUM

Performance data – page 107

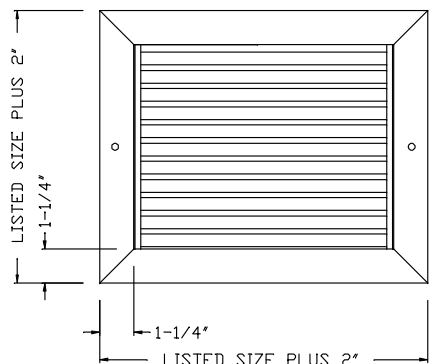



MODEL RHEF

Fixed Bar Return Air Filter Grille

EXTRUDED ALUMINUM

Performance data – page 107

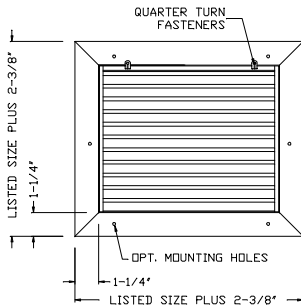

FEATURES

- Extruded aluminum construction
- Fixed horizontal blades set at 45 degrees
- Blades spaced at 2/3" centers
- Accepts standard 1" disposable filter
- Hinged face with 1/4 turn latches
- Face opens for access to filter box
- White finish

Height	Width												
	6"	8"	10"	12"	14"	16"	18"	20"	22"	24"	26"	28"	30"
4"	X	X	X	X	X	X	X	X	X	X	X	X	X
5"	X	X	X	X	X	X	X	X	X	X	X	X	X
6"	X	X	X	X	X	X	X	X	X	X	X	X	X
8"		X	X	X	X	X	X	X	X	X	X	X	X
10"			X	X	X	X	X	X	X	X	X	X	X
12"				X	X	X	X	X	X	X	X	X	X
14"					X	X	X	X	X	X	X	X	X
16"						X	X	X	X	X	X	X	X
18"							X	X	X	X	X	X	X
20"								X	X	X	X	X	X
22"									X	X	X	X	X
24"										X	X	X	X
26"											X	X	X
28"												X	X
30"													X

Other sizes available upon request

FEATURES

- Extruded aluminum construction
- 1/2" x 1/2" x 1/2" cube core
- Offers 90% free area
- Grille only for surface mount applications
- White finish

Height	Width												
	6"	8"	10"	12"	14"	16"	18"	20"	22"	24"	26"	28"	30"
4"	X	X	X	X	X	X	X	X	X	X	X	X	X
5"	X	X	X	X	X	X	X	X	X	X	X	X	X
6"	X	X	X	X	X	X	X	X	X	X	X	X	X
8"		X	X	X	X	X	X	X	X	X	X	X	X
10"			X	X	X	X	X	X	X	X	X	X	X
12"				X	X	X	X	X	X	X	X	X	X
14"					X	X	X	X	X	X	X	X	X
16"						X	X	X	X	X	X	X	X
18"							X	X	X	X	X	X	X
20"								X	X	X	X	X	X
22"									X	X	X	X	X
24"										X	X	X	X
26"											X	X	X
28"												X	X
30"													X

Other sizes available upon request

FEATURES

- Extruded aluminum construction
- 1/2" x 1/2" x 1/2" cube core
- Offers 90% free area
- Includes opposed blade damper
- White finish

Height	Width												
	6"	8"	10"	12"	14"	16"	18"	20"	22"	24"	26"	28"	30"
4"	X	X	X	X	X	X	X	X	X	X	X	X	X
5"	X	X	X	X	X	X	X	X	X	X	X	X	X
6"	X	X	X	X	X	X	X	X	X	X	X	X	X
8"		X	X	X	X	X	X	X	X	X	X	X	X
10"			X	X	X	X	X	X	X	X	X	X	X
12"				X	X	X	X	X	X	X	X	X	X
14"					X	X	X	X	X	X	X	X	X
16"						X	X	X	X	X	X	X	X
18"							X	X	X	X	X	X	X
20"								X	X	X	X	X	X
22"									X	X	X	X	X
24"										X	X	X	X
26"											X	X	X
28"												X	X
30"													X

Other sizes available upon request

MODEL CC5
Cube Core Return Air Grille
 EXTRUDED ALUMINUM

Performance data – page 107

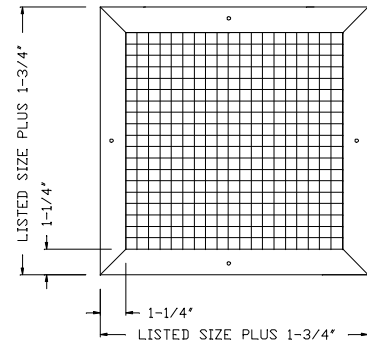
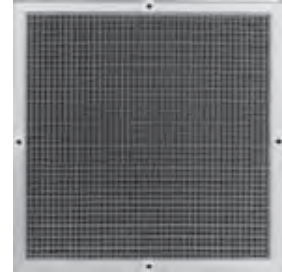
MODEL CC5D
Cube Core Return Air Grille w/OBD
 EXTRUDED ALUMINUM

Performance data – page 107

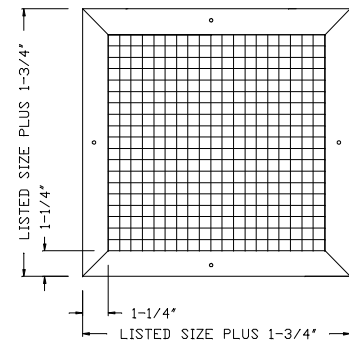
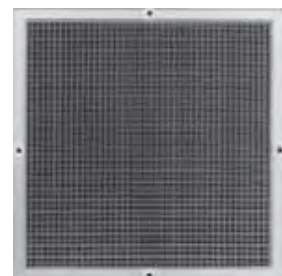



MODEL CC5F

Cube Core Return Air Filter Grille

EXTRUDED ALUMINUM

Performance data – page 107

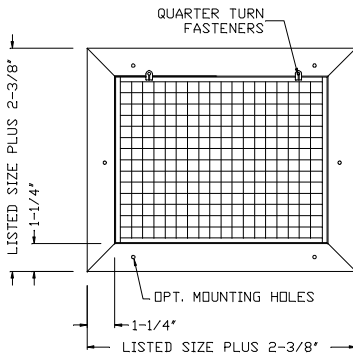

FEATURES

- Extruded aluminum construction
- 1/2" x 1/2" x 1/2" cube core
- Offers 90% free area
- Accepts 1" disposable filter (not included)
- Hinged face with 1/4 turn latches
- Face swings open for easy access to filter box
- White finish

Height	Width												
	6"	8"	10"	12"	14"	16"	18"	20"	22"	24"	26"	28"	30"
4"	X	X	X	X	X	X	X	X	X	X	X	X	X
5"	X	X	X	X	X	X	X	X	X	X	X	X	X
6"	X	X	X	X	X	X	X	X	X	X	X	X	X
8"		X	X	X	X	X	X	X	X	X	X	X	X
10"			X	X	X	X	X	X	X	X	X	X	X
12"				X	X	X	X	X	X	X	X	X	X
14"					X	X	X	X	X	X	X	X	X
16"						X	X	X	X	X	X	X	X
18"							X	X	X	X	X	X	X
20"								X	X	X	X	X	X
22"									X	X	X	X	X
24"										X	X	X	X
26"											X	X	X
28"												X	X
30"													X

Other sizes available upon request



FEATURES

5500 DAF-CC5-1 Flush Frame

5500 DAF-CC5-2 Bevel Frame

- Extruded aluminum louver outer 4 way supply
- Cube core center snap-in/out return
- Supply/return plenums by others
- White finish

Square Neck Sizes	
Supply	Return
12"x12"	9"x9"
15"x15"	9"x9"
18"x18"	12"x12"
	15"x15"
21"x21"	15"x15"
24"x24"	18"x18"
27"x27"	18"x18"
30"x30"	21"x21"

Other sizes available upon request

MODEL 5500 DAF-CC5

Concentric Supply/Return Diffuser, Louver Face/Cube Core, Surface Mount

EXTRUDED ALUMINUM

Performance data – page 108

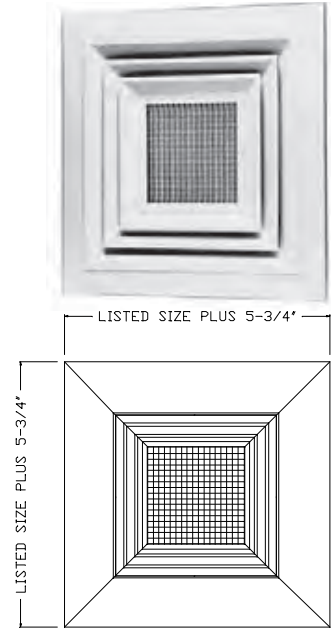

FEATURES

9000-1 Flush Frame

9000-2 Bevel Frame

- Extruded aluminum construction
- Snap-in modular core
- Provides one, two, three or four way air pattern
- White finish

Height	Width									
	6"	8"	10"	12"	14"	16"	18"	20"	22"	24"
6"	X									
8"		X								
10"			X							
12"				X						
14"					X					
16"						X				
18"							X			
20"								X		
22"									X	
24"										X

Other sizes available upon request

MODEL 9000

Mod Core Ceiling Diffuser

EXTRUDED ALUMINUM

Performance data – page 106

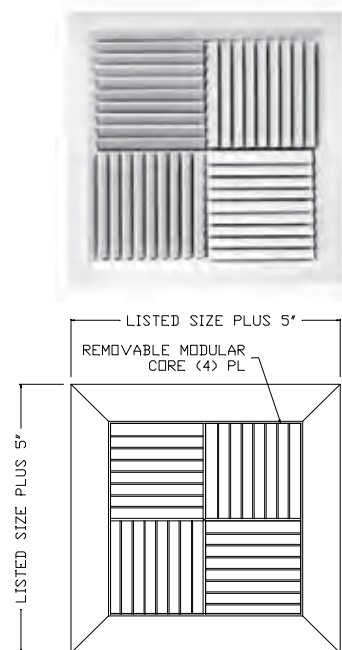



MODEL 4900

Square/Rectangular Louver Face Ceiling Diffuser

EXTRUDED ALUMINUM

Performance data – page 116

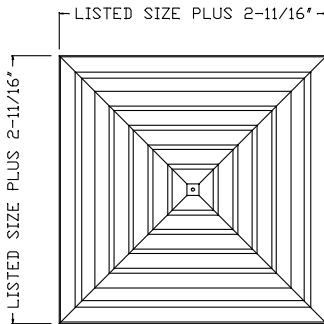
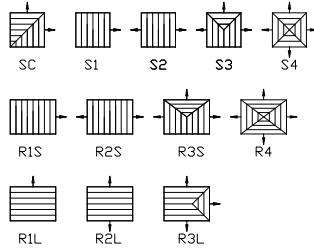

FEATURES

4900-1 Flush Frame

4900-2 Bevel Frame

- Extruded aluminum construction
- Square/rectangular sizes
- Louver face ceiling diffuser
- Surface mount
- Provides four way air pattern
- White finish

Height	Width								
	6"	9"	12"	15"	18"	21"	24"	27"	30"
6"	X	X	X	X	X	X	X	X	X
9"		X	X	X	X	X	X	X	X
12"			X	X	X	X	X	X	X
15"				X	X	X	X	X	X
18"					X	X	X	X	X
21"						X	X	X	X
24"							X	X	X
27"								X	X
30"									X

Other sizes available upon request

MODEL 4900D

Square/Rectangular Louver Face Ceiling Diffuser with OBD

EXTRUDED ALUMINUM

Performance data – page 116

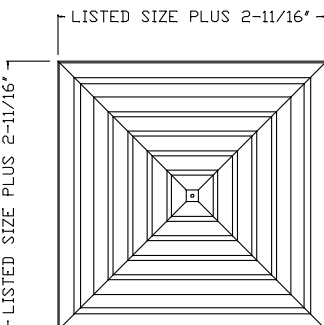
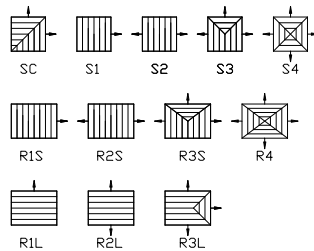

FEATURES

- Extruded aluminum construction
- Square/rectangular sizes
- Louver face ceiling diffuser
- Surface mount
- Provides four way air pattern
- Includes opposed blade damper
- White finish

Height	Width								
	6"	9"	12"	15"	18"	21"	24"	27"	30"
6"	X	X	X	X	X	X	X	X	X
9"		X	X	X	X	X	X	X	X
12"			X	X	X	X	X	X	X
15"				X	X	X	X	X	X
18"					X	X	X	X	X
21"						X	X	X	X
24"							X	X	X
27"								X	X
30"									X

Other sizes available upon request

FEATURES

- Extruded aluminum construction
- U-channel frame
- Fixed inverted 'V' blades set at 70 degrees
- Sightproof
- Blades spaced at 2/3" centers
- White finish

Height	Width												
	6"	8"	10"	12"	14"	16"	18"	20"	22"	24"	26"	28"	30"
4"	X	X	X	X	X	X	X	X	X	X	X	X	X
5"	X	X	X	X	X	X	X	X	X	X	X	X	X
6"	X	X	X	X	X	X	X	X	X	X	X	X	X
8"		X	X	X	X	X	X	X	X	X	X	X	X
10"			X	X	X	X	X	X	X	X	X	X	X
12"				X	X	X	X	X	X	X	X	X	X
14"					X	X	X	X	X	X	X	X	X
16"						X	X	X	X	X	X	X	X
18"							X	X	X	X	X	X	X
20"								X	X	X	X	X	X
22"									X	X	X	X	X
24"										X	X	X	X
26"											X	X	X
28"												X	X
30"													X

MODEL DG
Transfer Door Grille
 EXTRUDED ALUMINUM

Performance data – page 106

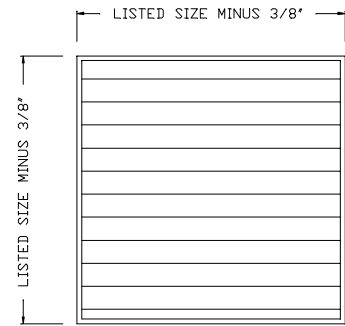
FEATURES

- Extruded aluminum construction
- Fixed inverted 'V' blades set at 70 degrees
- Sightproof
- Blades spaced at 2/3" centers
- 2 sided telescoping frame
- Fits door 1 1/16" to 2 1/8" thick
- White finish

Height	Width												
	6"	8"	10"	12"	14"	16"	18"	20"	22"	24"	26"	28"	30"
4"	X	X	X	X	X	X	X	X	X	X	X	X	X
5"	X	X	X	X	X	X	X	X	X	X	X	X	X
6"	X	X	X	X	X	X	X	X	X	X	X	X	X
8"		X	X	X	X	X	X	X	X	X	X	X	X
10"			X	X	X	X	X	X	X	X	X	X	X
12"				X	X	X	X	X	X	X	X	X	X
14"					X	X	X	X	X	X	X	X	X
16"						X	X	X	X	X	X	X	X
18"							X	X	X	X	X	X	X
20"								X	X	X	X	X	X
22"									X	X	X	X	X
24"										X	X	X	X
26"											X	X	X
28"												X	X
30"													X

Other sizes available upon request

MODEL DGDF
Transfer Door Grille
 w/ Telescoping Frame (2 Sides)
 EXTRUDED ALUMINUM

Performance data – page 106

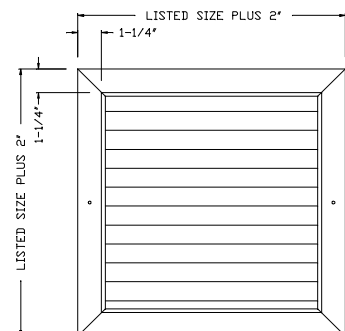



MODEL DGSF

Transfer Door Grille w/Partition Frame (1 Side)

EXTRUDED ALUMINUM

Performance data – page 106

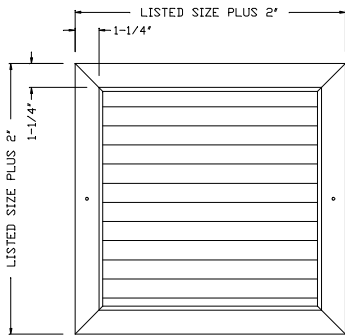

FEATURES

- Extruded aluminum construction
- Fixed inverted 'V' blades set at 70 degrees
- Sightproof
- Blades spaced at 2/3" centers
- 1 sided partition frame
- White finish

Height	Width												
	6"	8"	10"	12"	14"	16"	18"	20"	22"	24"	26"	28"	30"
4"	X	X	X	X	X	X	X	X	X	X	X	X	X
5"	X	X	X	X	X	X	X	X	X	X	X	X	X
6"	X	X	X	X	X	X	X	X	X	X	X	X	X
8"		X	X	X	X	X	X	X	X	X	X	X	X
10"			X	X	X	X	X	X	X	X	X	X	X
12"				X	X	X	X	X	X	X	X	X	X
14"					X	X	X	X	X	X	X	X	X
16"						X	X	X	X	X	X	X	X
18"							X	X	X	X	X	X	X
20"								X	X	X	X	X	X
22"									X	X	X	X	X
24"										X	X	X	X
26"											X	X	X
28"												X	X
30"													X

FEATURES

3100A – Aluminum construction

3100SA – Steel construction

- Low profile flush face
- Fully adjustable 2 cone diffuser
- Adjustable from horizontal to vertical discharge
- White finish

Round Neck Sizes									
6"	8"	10"	12"	14"	16"	18"	20"	24"	
X	X	X	X	X	X	X	X	X	X

SIZE	A	B
6"	16-1/8"	2-3/4"
8"	16-1/8"	2-3/4"
10"	21-7/8"	3-1/8"
12"	21-7/8"	3-1/8"
14"	28-3/4"	3-7/8"
16"	28-3/4"	3-7/8"
18"	34-3/8"	5"
20"	34-3/8"	5"
24"	40-3/8"	5-1/2"

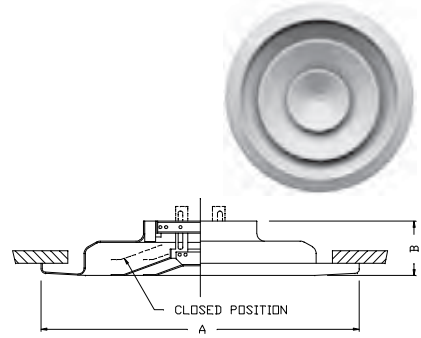

MODEL 3100A/3100SA

Commercial Round – Adjustable Core

ALUMINUM/STEEL

Performance data – page 103

FEATURES

3100 – Aluminum construction

3100S – Steel construction

- Low profile flush face
- Fixed 2 cone core
- White finish

Round Neck Sizes										
6"	8"	10"	12"	14"	16"	18"	20"	24"	30"	
X	X	X	X	X	X	X	X	X	X	X

SIZE	A	B
6"	16-1/8"	2-3/4"
8"	16-1/8"	2-3/4"
10"	21-7/8"	3-1/8"
12"	21-7/8"	3-1/8"
14"	28-3/4"	3-7/8"
16"	28-3/4"	3-7/8"
18"	34-3/8"	5"
20"	34-3/8"	5"
24"	40-3/8"	5-1/2"

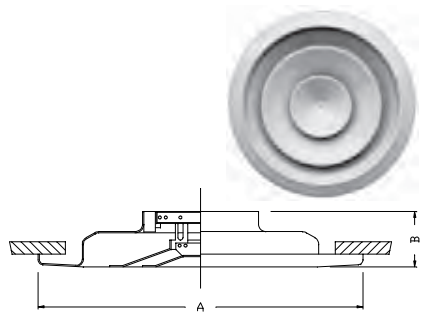

MODEL 3100/3100S

Commercial Round – Fixed Core

ALUMINUM/STEEL

Performance data – page 103

FEATURES

D3 – Aluminum construction

SD3 – Steel construction

- Radial opposed blade damper
- Mill finish

Damper Neck Sizes									
6"	8"	10"	12"	14"	16"	18"	20"	24"	30"
X	X	X	X	X	X	X	X	X	X

MODEL D3/SD3

Radial Opposed Blade Damper

ALUMINUM/STEEL

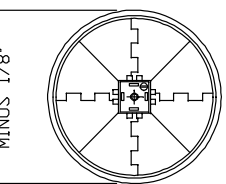
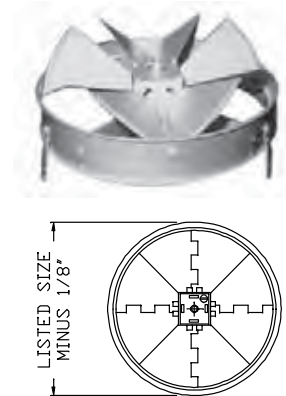



MODEL 4004P

Spiral Pipe Grille w/Scoop

ALUMINUM

Performance data – page 102

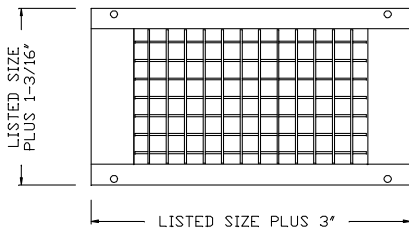

FEATURES

- Aluminum construction
- Exposed spiral duct applications
- Vertical front blades
- Can be installed in round duct diameters from 10" to 48"
- Integral gasket seals grille tightly to duct
- Includes built-in scoop extractor
- Scoop allows for accurate balancing and air control
- White finish, mill finish optional

Height	Width										
	10"	12"	14"	16"	18"	20"	22"	24"	26"	28"	30"
3"	X	X	X	X	X	X	X	X	X	X	X
4"	X	X	X	X	X	X	X	X	X	X	X
6"	X	X	X	X	X	X	X	X	X	X	X
8"			X	X	X	X	X	X	X	X	X
10"				X	X	X	X	X	X	X	X
12"					X	X	X	X	X	X	X

Other sizes available upon request

COMMERCIAL

MODEL 4004SP

Spiral Pipe Grille w/Scoop

GALVANIZED STEEL

Performance data – page 102

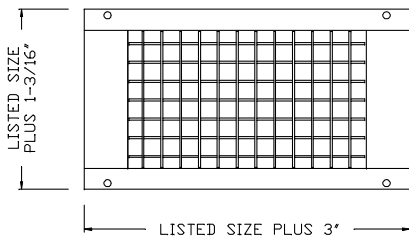

FEATURES

- Galvanized steel construction
- Exposed spiral duct applications
- Vertical front blades
- Can be installed in round duct diameters from 10" to 48"
- Integral gasket seals grille tightly to duct
- Includes built-in scoop extractor
- Scoop allows for accurate balancing and air control
- Mill finish

Height	Width										
	10"	12"	14"	16"	18"	20"	22"	24"	26"	28"	30"
3"	X	X	X	X	X	X	X	X	X	X	X
4"	X	X	X	X	X	X	X	X	X	X	X
6"	X	X	X	X	X	X	X	X	X	X	X
8"		X	X	X	X	X	X	X	X	X	X
10"				X	X	X	X	X	X	X	X
12"					X	X	X	X	X	X	X

Other sizes available upon request

SPIRAL DIFFUSERS

FEATURES

- Extruded aluminum construction
- Designed for floor applications
- 7/32" bars set at 1/2" centers
- Cross bracing
- Clear anodized finish

Height	Width					
	10"	12"	14"	24"	36"	48"
2"	X	X	X			
4"	X	X	X	X	X	X
6"	X	X	X	X	X	X

Other sizes available upon request

MODEL 2000F
Linear Bar Floor Grille
 EXTRUDED ALUMINUM

Performance data – page 101

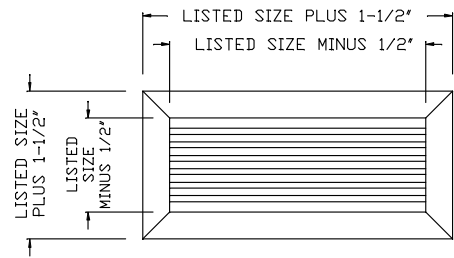
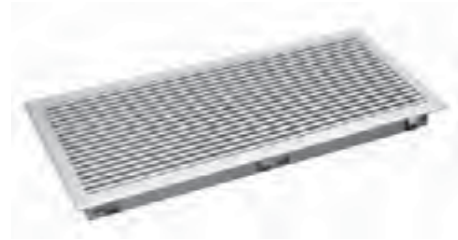
FEATURES

- Extruded aluminum construction
- Designed for floor applications
- 7/32" bars set at 1/2" centers
- Includes opposed blade damper
- Cross bracing
- Clear anodized finish

Height	Width					
	10"	12"	14"	24"	36"	48"
2"	X	X	X			
4"	X	X	X	X	X	X
6"	X	X	X	X	X	X

Other sizes available upon request

MODEL 2000FD
Linear Bar Floor Grille w/OBD
 EXTRUDED ALUMINUM

Performance data – page 101

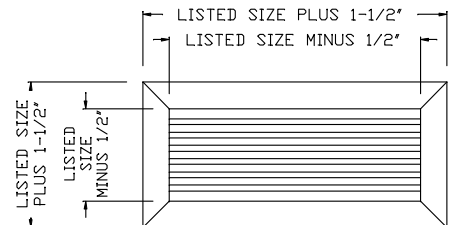
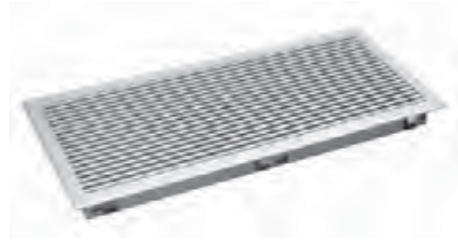



MODEL 6600

Linear Slot Diffuser

EXTRUDED ALUMINUM

Performance data – pages 110-112



FEATURES

6650 – 1/2" slot

6675 – 3/4" slot

6610 – 1" slot

- Extruded aluminum construction
- Available in 1 to 4 slots
- Available in 2', 3', 4' and 5' lengths
- Pattern controllers are adjustable from face
- Volume or throw direction able to be adjusted from vertical to horizontal
- Optional BP Boot Plenum available
- Optional BPI Insulated Boot Plenum available
- White finish

Length	1,2,3,4 Slot
24"	X
36"	X
48"	X
60"	X

COMMERCIAL

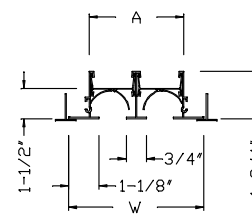
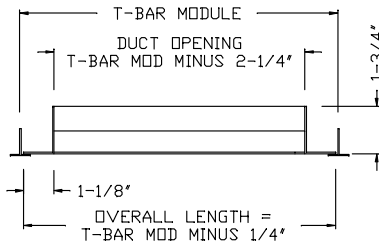
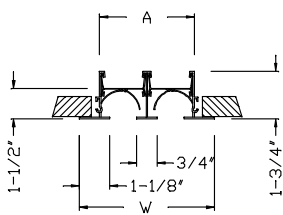
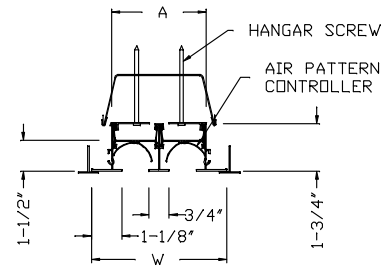
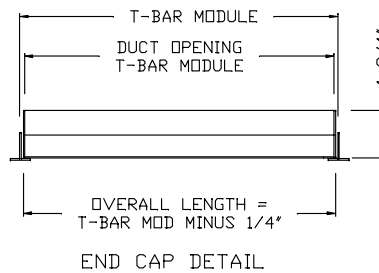
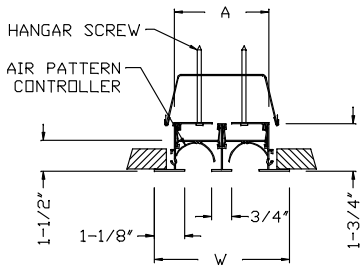

MODEL 6650 - 1/2" SLOT				
NUMBER OF AIR SLOTS				
	1	2	3	4
A	1-1/4"	2-1/2"	3-3/4"	5"
W	2-3/4"	4"	5-1/4"	6-1/2"

MODEL 6675 - 3/4" SLOT				
NUMBER OF AIR SLOTS				
	1	2	3	4
A	1-1/2"	3"	4-1/2"	6"
W	3"	4-1/2"	6"	7-1/2"

MODEL 6610 - 1" SLOT				
NUMBER OF AIR SLOTS				
	1	2	3	4
A	1-3/4"	3-1/2"	5-1/4"	7"
W	3-1/4"	5"	6-3/4"	8-1/2"

LINEARS AND SLOT DIFFUSERS



FEATURES

PHPR-50 – 1/2" slot

PHPR-75 – 3/4" slot

PHPR-10 – 1" slot

PHPR-15 – 1-1/2" slot

- Extruded aluminum construction
- Available in 1 to 4 slots
- Available in 2', 3', 4' and 5' lengths
- Offers low pressure drop
- Integral light shield hides interior of unit
- Plenum inlets available in 6", 8", 10" and 12"
- White finish

Length	1,2,3,4 Slot
24"	X
36"	X
48"	X
60"	X

Other sizes available upon request

MODEL PHPR

Plenum Slot Return Diffuser, T-Bar

ALUMINUM/STEEL

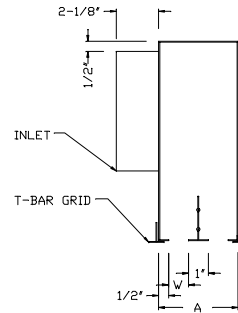

MODEL PHPR		1 SLOT	2 SLOT	3 SLOT	4 SLOT	
	W	A	A	A	A	
	L	A	A	A	A	
PHPR-50-6	1/2'	24", 36", 48", 60"	1-1/2'	3'	4-1/2'	6'
PHPR-75-6	3/4'	24", 36", 48", 60"	1-3/4'	3-1/2'	5-1/4'	7'
PHPR-10-6	1'	24", 36", 48", 60"	2'	4'	6'	8'
PHPR-15-6	1-1/2'	24", 36", 48", 60"	2-1/2'	5'	7-1/2'	10'

FEATURES

PHPS-50 – 1/2" slot

PHPS-75 – 3/4" slot

PHPS-10 – 1" slot

PHPS-15 – 1-1/2" slot

- Extruded aluminum construction
- Available in 1 to 4 slots
- Available in 2', 3', 4' and 5' lengths
- Pattern controllers are adjustable from face
- Volume or throw direction able to be adjusted from vertical to horizontal
- Plenum inlets available in 6", 8", 10" and 12"
- White finish

Length	1,2,3,4 Slot
24"	X
36"	X
48"	X
60"	X

Other sizes available upon request

MODEL PHPS

Plenum Slot Supply Diffuser, T-Bar

ALUMINUM/STEEL

Performance data – pages 113-114

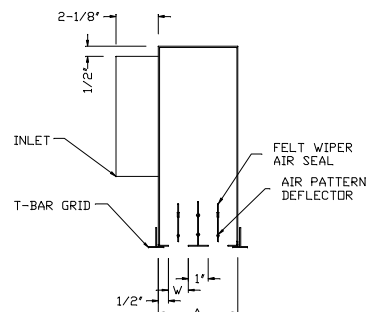

MODEL PHPS		1 SLOT	2 SLOT	3 SLOT	4 SLOT	
	W	A	A	A	A	
	L	A	A	A	A	
PHPS-50-6	1/2'	24", 36", 48", 60"	1-1/2'	3'	4-1/2'	6'
PHPS-75-6	3/4'	24", 36", 48", 60"	1-3/4'	3-1/2'	5-1/4'	7'
PHPS-10-6	1'	24", 36", 48", 60"	2'	4'	6'	8'
PHPS-15-6	1-1/2'	24", 36", 48", 60"	2-1/2'	5'	7-1/2'	10'



MODEL PHPRI

Insulated Plenum Slot Return Diffuser, T-Bar
ALUMINUM/STEEL

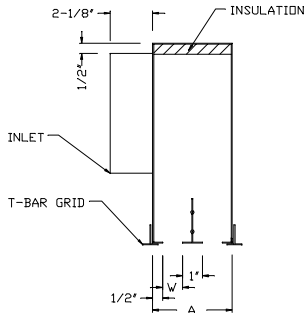

MODEL PHPRI		1 SLOT	2 SLOT	3 SLOT	4 SLOT
	W	L	A	A	A
PHPRI-50-6	1/2"	24", 36", 48", 60"	1-1/2"	3"	4-1/2"
PHPRI-75-6	3/4"	24", 36", 48", 60"	1-3/4"	3-1/2"	5-1/4"
PHPRI-10-6	1"	24", 36", 48", 60"	2"	4"	6"
PHPRI-15-6	1-1/2"	24", 36", 48", 60"	2-1/2"	5"	7-1/2"

FEATURES

PHPR-50 – 1/2" slot

PHPR-75 – 3/4" slot

PHPR-10 – 1" slot

PHPR-15 – 1-1/2" slot

- Extruded aluminum construction
- Available in 1 to 4 slots
- Available in 2', 3', 4' and 5' lengths
- Offers low pressure drop
- Integral light shield hides interior of unit
- Plenum inlets available in 6", 8", 10" and 12"
- White finish

Length	1,2,3,4 Slot
24"	X
36"	X
48"	X
60"	X

Other sizes available upon request

COMMERCIAL

MODEL PHPSI

Insulated Plenum Slot Supply Diffuser, T-Bar
ALUMINUM/STEEL

Performance data – pages 113-114

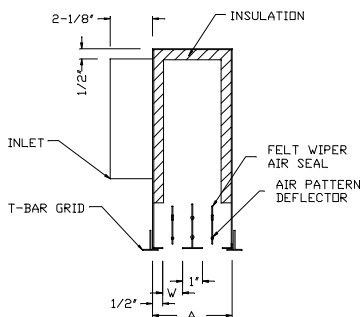

MODEL PHPSI		1 SLOT	2 SLOT	3 SLOT	4 SLOT
	W	L	A	A	A
PHPSI-50-6	1/2"	24", 36", 48", 60"	1-1/2"	3"	4-1/2"
PHPSI-75-6	3/4"	24", 36", 48", 60"	1-3/4"	3-1/2"	5-1/4"
PHPSI-10-6	1"	24", 36", 48", 60"	2"	4"	6"
PHPSI-15-6	1-1/2"	24", 36", 48", 60"	2-1/2"	5"	7-1/2"

FEATURES

PHPS-50 – 1/2" slot

PHPS-75 – 3/4" slot

PHPS-10 – 1" slot

PHPS-15 – 1 1/2" slot

- Extruded aluminum construction
- Available in 1 to 4 slots
- Available in 2', 3', 4' and 5' lengths
- Pattern controllers are adjustable from face
- Volume or throw direction able to be adjusted from vertical to horizontal
- Plenum inlets available in 6", 8", 10" and 12"
- White finish

Length	1,2,3,4 Slot
24"	X
36"	X
48"	X
60"	X

Other sizes available upon request

LINEARS AND SLOT DIFFUSERS



FEATURES

- Steel construction
- 24" x 24" T-bar lay-in
- 1/2" stamped louver face
- Concealed hinges and latches
- Accepts 1" disposable filter (not included)
- White finish

MODEL 1410FTB

Return Air Filter Grille, T-Bar

STEEL

Performance data – page 100

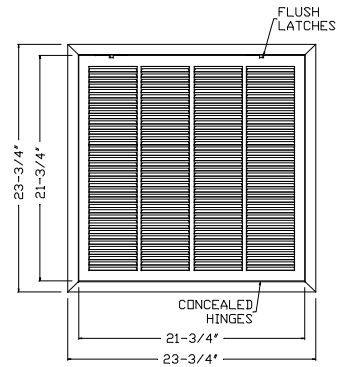

FEATURES

- Steel construction
- 24" x 24" T-Bar Lay-in
- 1/2" stamped louver face
- Concealed hinges and latches
- Accepts 1" disposable filter (not included)
- Includes R6 molded fiberglass back
- White finish

MODEL 1410FTBI

Return Air Filter Grille w/R6 Molded Back, T-Bar

STEEL

Performance data – page 100

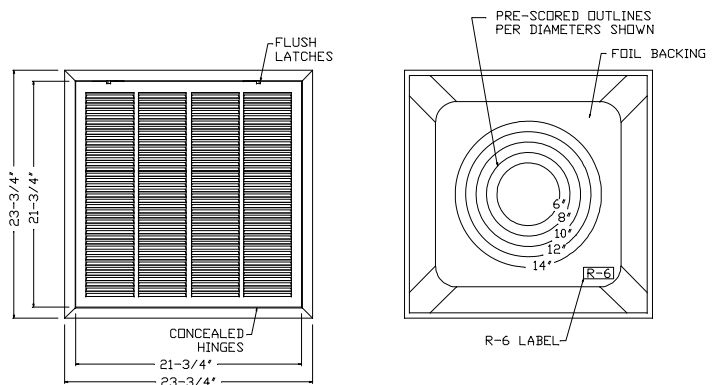

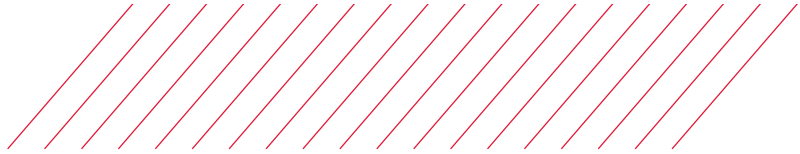

MODEL 1420F

Return Air Filter Grille, T-Bar w/Plenum Back
STEEL

Performance data – page 100

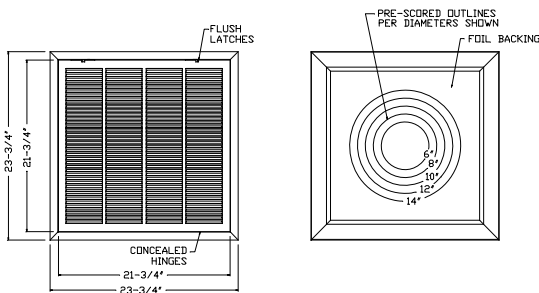

FEATURES

- Steel construction
- 24" x 24" T-bar lay-in
- 1/2" stamped louver face
- Concealed hinges and latches
- Accepts 1" disposable filter (not included)
- R6 fiberglass back plenum accepts 6" to 18" round spin-in collars (not included)
- White finish

COMMERCIAL

MODEL SRH-6

Fixed Bar Return Air Grille, T-Bar
STEEL

Performance data – page 107

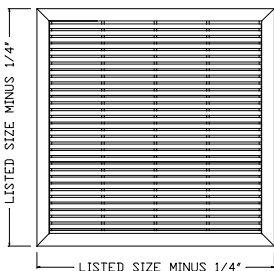

FEATURES

- Steel construction
- T-bar lay-in
- 2/3" Bar Spacing
- Horizontal bars are fixed at 45 degrees
- White finish

Height	Width	
	24"	48"
12"	X	
24"	X	X

LINEARS AND SLOT DIFFUSERS



FEATURES

- Steel construction
- 24" x 24" T-bar lay-in
- 2/3" bar spacing
- Horizontal bars are fixed at 45 degrees
- Concealed hinges
- 1/4 turn latches for easy access to filter box
- Accepts 1" disposable filter (not included)
- White finish

MODEL SRHF-6

Fixed Bar Return Air Filter Grille, T-Bar
STEEL

Performance data – page 107

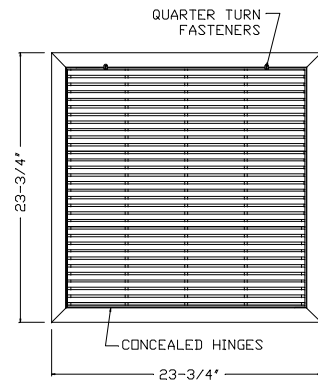

FEATURES

- Steel construction
- 24" x 24" T-bar lay-in
- 2/3" bar spacing
- Horizontal bars are fixed at 45 degrees
- Concealed hinges
- 1/4 turn latches for easy access to filter box
- Accepts 1" disposable filter (not included)
- Includes R6 molded fiberglass back
- White finish

MODEL SRHF1-6

Fixed Bar Return Air Filter Grille w/R6 Molded Back, T-Bar
STEEL

Performance data – page 107

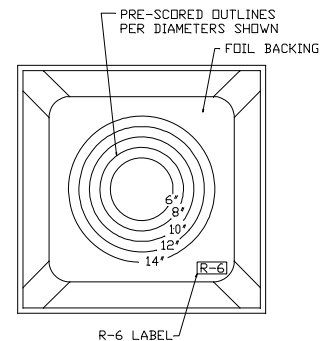
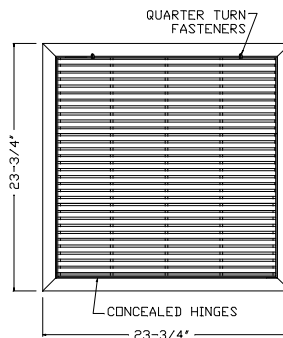

COMMERCIAL

T-BAR DIFFUSERS

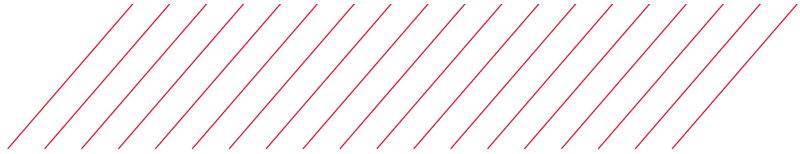

MODEL SRH20F

Fixed Bar Return Air Filter Grille, T-Bar w/ Plenum Back

STEEL

Performance data – page 107



FEATURES

- Steel construction
- 24" x 24" T-bar lay-in
- 2/3" bar spacing
- Horizontal bars are fixed at 45 degrees
- Concealed hinges
- 1/4 turn latches for easy access to filter box
- Accepts 1" disposable filter (not included)
- 5" deep plenum
- R6 fiberglass back plenum accepts 6" to 18" round spin-in collars (not included)
- White finish

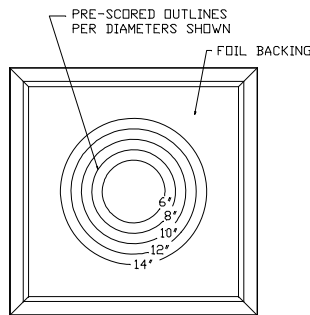
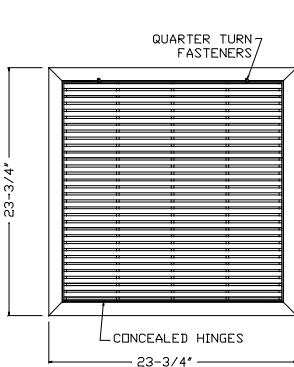

COMMERCIAL

MODEL RHTB

Fixed Bar Return Air Grille, T-Bar

ALUMINUM

Performance data – page 107



FEATURES

- Aluminum construction
- T-bar lay-in
- 2/3" bar spacing
- Horizontal bars are fixed at 45 degrees
- Grille only
- White finish

Height	Width	
	24"	48"
12"	X	
24"	X	X

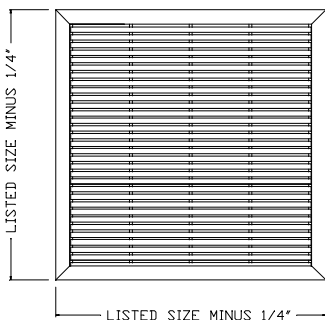

T-BAR DIFFUSERS



FEATURES

- Aluminum construction
- T-bar lay-in
- 2/3" bar spacing
- Horizontal bars are fixed at 45 degrees
- Concealed hinges
- 1/4 turn latches for access to filter box
- Accepts nominal 1" filters (not included)
- White finish

Height	Width		
	24"	36"	48"
12"	X		
24"	X	X	X

MODEL RHFTB

Fixed Bar Return Air Filter Grille, T-Bar
ALUMINUM

Performance data – page 107

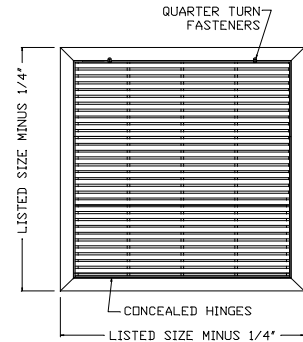

FEATURES

- Aluminum construction
- 24" x 24" T-bar lay-in
- 2/3" bar spacing
- Horizontal bars are fixed at 45 degrees
- Concealed hinges
- 1/4 turn latches for access to filter box
- Accepts nominal 1" filters (not included)
- Includes R6 molded fiberglass back
- White finish

MODEL RHFTBI

Fixed Bar Return Air Filter Grille w/R6 Molded Back, T-Bar
ALUMINUM

Performance data – page 107

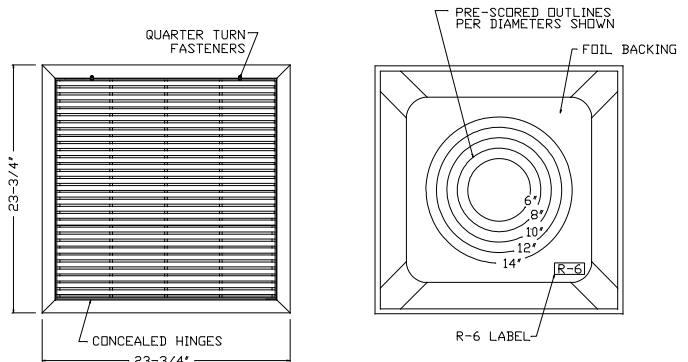

COMMERCIAL

T-BAR DIFFUSERS

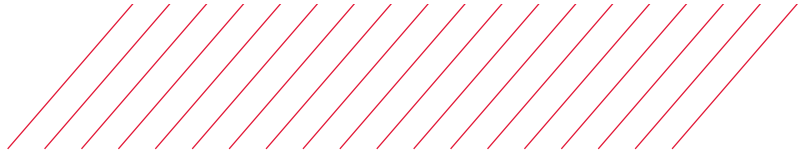

MODEL RH20F

Fixed Bar Return Air Filter Grille, T-Bar w/ Plenum Back

ALUMINUM

Performance data – page 107



FEATURES

- Aluminum construction
- 24" x 24" T-bar lay-in
- Horizontal bar type face at 2/3" centers
- Blades set at 45 degrees
- Concealed hinges
- 1/4 turn latches for easy access to filter box
- Accepts 1" disposable filter (not included)
- 5" deep plenum
- R6 fiberglass back plenum accepts 6" to 18" round spin-in collars (not included)
- White finish

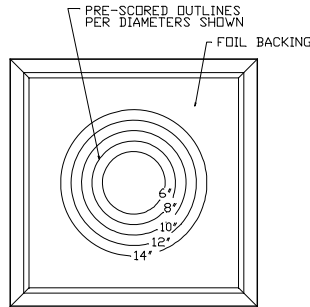
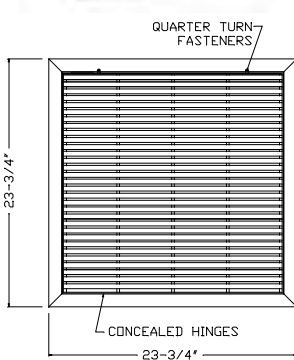

COMMERCIAL

MODEL RHETB

Fixed Bar Return Air Grille, T-Bar

EXTRUDED ALUMINUM

Performance data – page 107



FEATURES

- Extruded aluminum construction
- T-bar lay-in
- 2/3" bar spacing
- Horizontal bars are fixed at 45 degrees
- Grille only
- White finish

Height	Width	
	24"	48"
12"	X	
24"	X	X

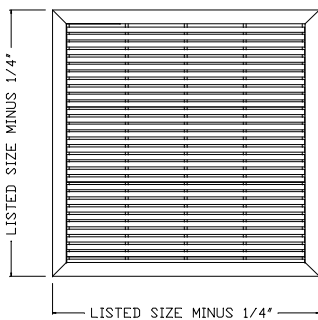

T-BAR DIFFUSERS



FEATURES

- Extruded aluminum construction
- T-bar lay-in
- 2/3" bar spacing
- Horizontal bars are fixed at 45 degrees
- Concealed hinges
- 1/4 turn latches for access to filter box
- Accepts nominal 1" filters (not included)
- White finish

Height	Width		
	24"	36"	48"
12"	X		
24"	X	X	X

MODEL RHEFTB

Fixed Bar Return Air Filter Grille, T-Bar

EXTRUDED ALUMINUM

Performance data – page 107

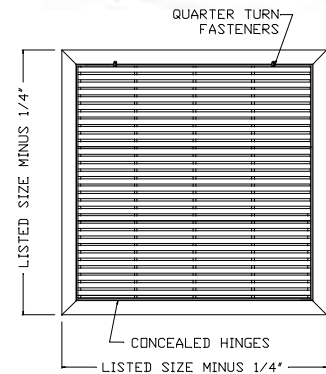

FEATURES

- Aluminum construction
- 24" x 24" T-bar lay-in
- 2/3" bar spacing
- Horizontal bars are fixed at 45 degrees
- Concealed hinges
- 1/4 turn latches for access to filter box
- Accepts nominal 1" filters (not included)
- Includes R6 molded fiberglass back
- White finish

MODEL RHEFTBI

Fixed Bar Return Air Filter Grille w/R6 Molded Back, T-Bar

EXTRUDED ALUMINUM

Performance data – page 107

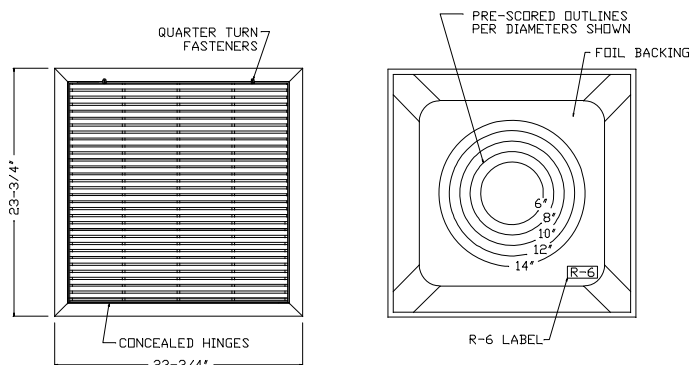



MODEL CC5TB

Cube Core Return Air Grille, T-Bar

EXTRUDED ALUMINUM

Performance data – page 107

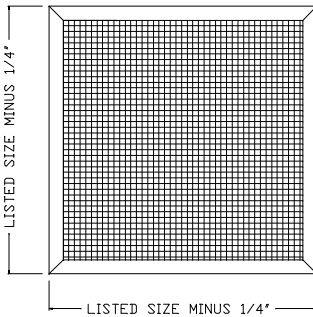
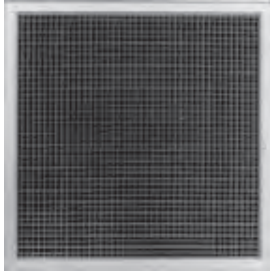

FEATURES

- Extruded aluminum construction
- 24" x 24" T-bar lay-in
- 1/2" x 1/2" x 1/2" cube core
- Offers 90% free area
- Grille only
- White finish

Module	24"	48"
12"	X	
24"	X	X

COMMERCIAL

MODEL CC5DTB

Cube Core Return Air Grille w/OBD, T-Bar

EXTRUDED ALUMINUM

Performance data – page 107

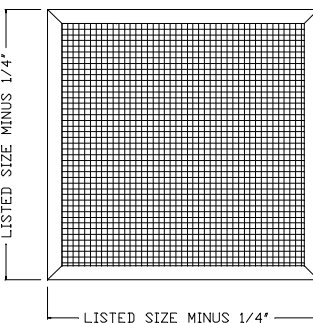
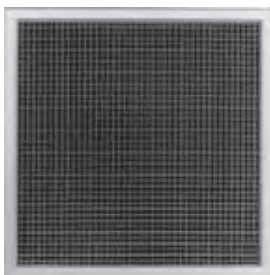

FEATURES

- Extruded aluminum construction
- T-bar lay-in
- 1/2" x 1/2" x 1/2" cube core
- Offers 90% free area
- Includes opposed blade damper
- White finish

Module	24"	48"
12"	X	
24"	X	X

T-BAR DIFFUSERS



FEATURES

- Extruded aluminum construction
- T-bar lay-in
- 1/2" x 1/2" x 1/2" cube core
- Offers 90% free area
- Accepts nominal 1" filter (not included)
- Concealed hinges
- 1/4 turn latches for easy access to damper box
- White finish

Module	24"	48"
12"	X	
24"	X	X

MODEL CC5FTB

Cube Core Return Air Filter Grille, T-Bar

EXTRUDED ALUMINUM

Performance data – page 107

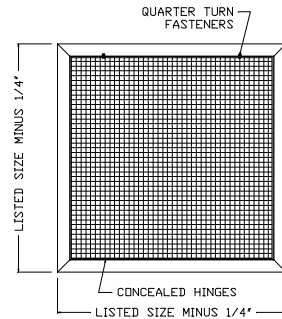
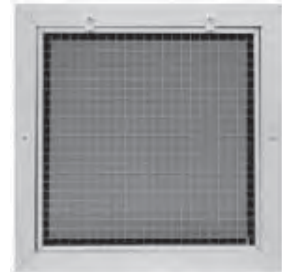

FEATURES

- Extruded aluminum construction
- 24"x24" T-bar lay-in
- 1/2" x 1/2" x 1/2" cube core
- Offers 90% free area
- Accepts nominal 1" filter (not included)
- Concealed hinges
- 1/4 turn latches for easy access to damper box
- Includes R6 molded fiberglass back
- White finish

MODEL CC5FTBI

Cube Core Return Air Filter Grille w/R6 Molded Back, T-Bar

EXTRUDED ALUMINUM

Performance data – page 107

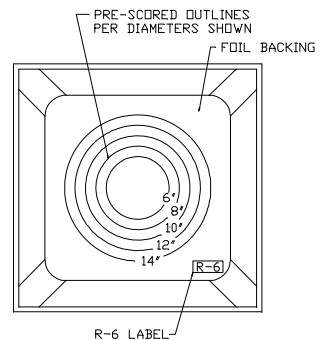
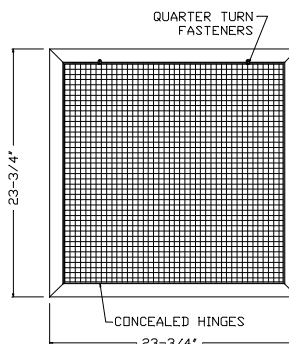

COMMERCIAL

T-BAR DIFFUSERS

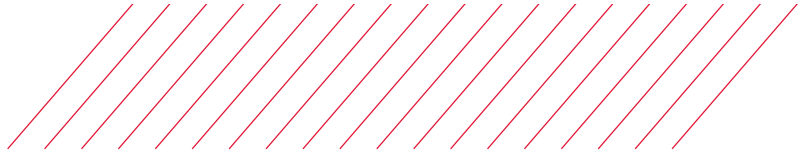

MODEL CC520F

Cube Core Return Air Filter Grille, T-Bar w/Plenum Back

EXTRUDED ALUMINUM

Performance data – page 107



FEATURES

- Aluminum construction
- 24" x 24" T-bar lay-in
- 1/2" x 1/2" x 1/2" cube core
- Offers 90% free area
- Concealed hinges
- 1/4 turn latches for easy access to filter box
- Accepts 1" disposable filter (not included)
- 5" deep plenum
- R6 fiberglass back plenum accepts 6"-18" round spin-in collars (not included)
- White finish

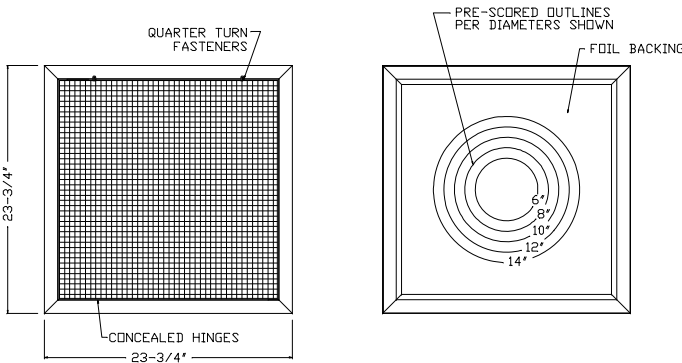

COMMERCIAL

MODEL CC5C0

Cube Core Return Air Grille, T-Bar, Core Only

EXTRUDED ALUMINUM

Performance data – page 107

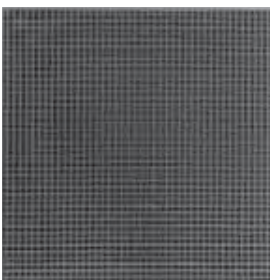

FEATURES

- Extruded aluminum construction
- T-bar lay-in
- 1/2" x 1/2" x 1/2" cube core
- Offers 90% free area
- Core only, channel frame
- White finish

Module	24"	48"
12"	X	
24"	X	X

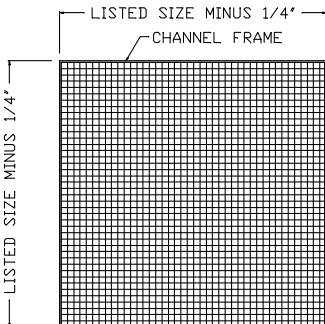

T-BAR DIFFUSERS

FEATURES

- All aluminum construction
- 24" x 24" T-bar lay-in
- Face/frame only in panel
- Removable core
- White finish

- Patterns: S1 – One Way S2 – Two Way
S3 – Three Way S4 – Four Way

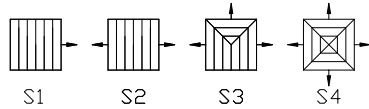

	Height	Width						
		6"	8"	10"	12"	14"	16"	18"
Module Size 24"x24"	6"	X						
	8"		X					
	10"			X				
	12"				X			
	14"					X		
	16"						X	
	18"							X

MODEL 5200-6
Louver Face Ceiling Diffuser, T-Bar
 ALUMINUM

Performance data – page 103

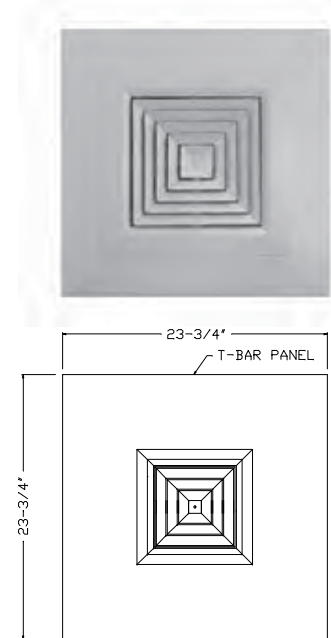
FEATURES

- All aluminum construction
- 24" x 24" T-bar lay-in
- Removable core
- Includes opposed blade damper
- White finish

- Patterns: S1 – One Way S2 – Two Way
S3 – Three Way S4 – Four Way

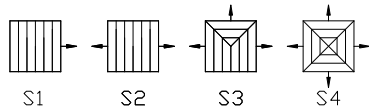

	Height	Width						
		6"	8"	10"	12"	14"	16"	18"
Module Size 24"x24"	6"	X						
	8"		X					
	10"			X				
	12"				X			
	14"					X		
	16"						X	
	18"							X

MODEL 5200-6D
Louver Face Ceiling Diffuser w/OBD, T-Bar
 ALUMINUM

Performance data – page 103

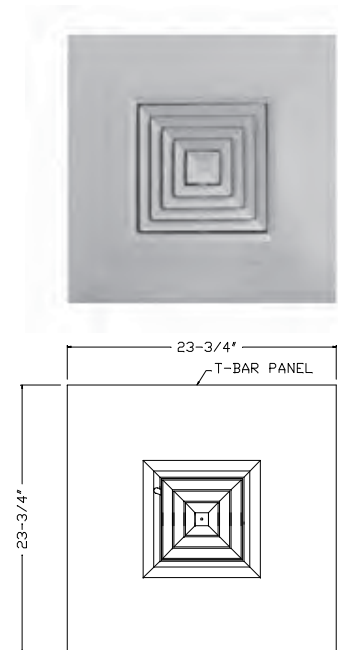



MODEL 5200-6 2C

Louver Face Ceiling Diffuser, Corner, T-Bar
ALUMINUM

Performance data – page 103

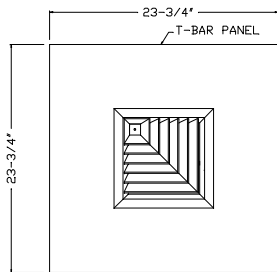

FEATURES

- All aluminum construction
- 24" x 24" T-bar lay-in
- Face/frame only in panel
- Removable core
- White finish
- Pattern: 2C – Two Way Corner



2C

	Height	Width						
		6"	8"	10"	12"	14"	16"	18"
Module Size 24"x24"	6"	X						
	8"		X					
	10"			X				
	12"				X			
	14"					X		
	16"						X	
	18"							X

MODEL 5200-6D 2C

Louver Face Ceiling Diffuser, Corner,
w/OBD, T-Bar
ALUMINUM

Performance data – page 103

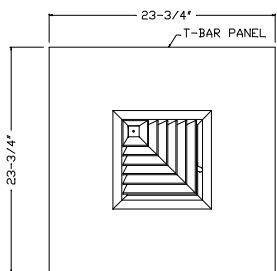

FEATURES

- All aluminum construction
- 24" x 24" T-bar lay-in
- Removable core
- Includes opposed blade damper
- White Finish
- Pattern: 2C – Two Way Corner



2C

	Height	Width						
		6"	8"	10"	12"	14"	16"	18"
Module Size 24"x24"	6"	X						
	8"		X					
	10"			X				
	12"				X			
	14"					X		
	16"						X	
	18"							X



FEATURES

- Steel construction
- 24" x 24" T-bar lay-in
- Expanded metal face panel
- R6 molded fiberglass back panel
- Includes round disk on face
- White finish

MODEL 7300-6

**Expanded Metal Supply w/Round Disk,
R6 Molded Back, T-Bar**

STEEL

Performance data – page 115

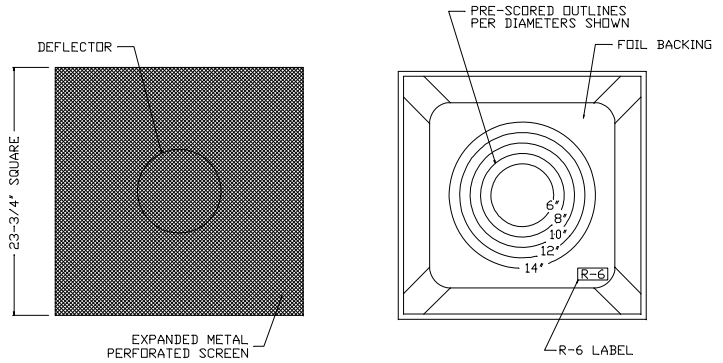

COMMERCIAL

FEATURES

- All aluminum construction
- 24" x 24" T-bar lay-in
- Expanded metal face panel
- R6 molded fiberglass back panel
- Used for return applications
- White finish

MODEL 7300R-6

Expanded Metal Return, R6 Molded Back, T-Bar

STEEL

Performance data – page 115

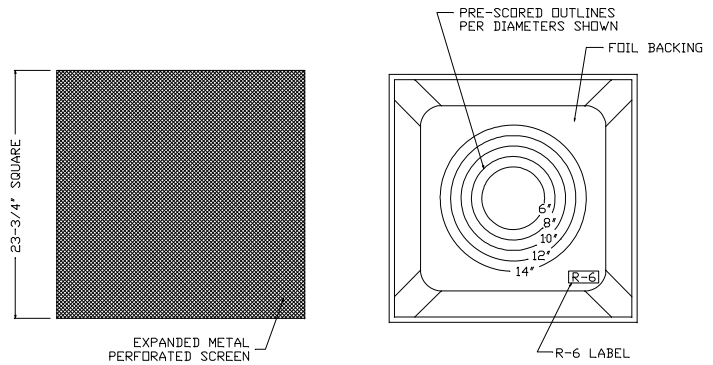

T-BAR DIFFUSERS

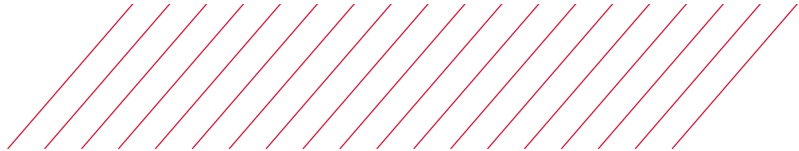

MODEL 7305-6

Expanded Metal Supply w/Adjustable Deflectors, R6 Molded Back, T-Bar

STEEL

Performance data – page 115



FEATURES

- Steel construction
- 24" x 24" T-bar lay-in
- Expanded metal face panel
- R6 molded fiberglass back panel
- Includes adjustable deflectors on face panel
- White finish

COMMERCIAL

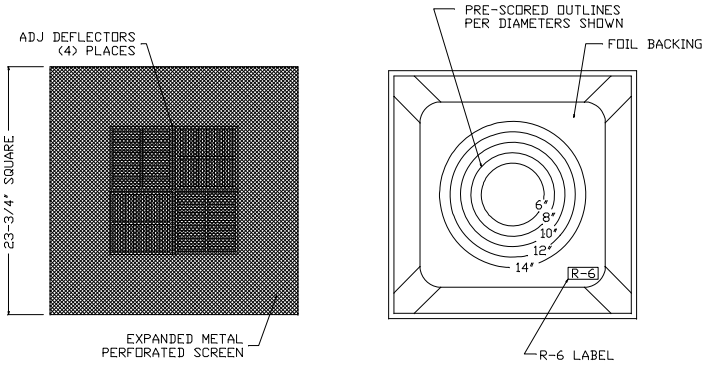

MODEL SPRTB

Perforated Panel – Face Only, T-Bar

STEEL

Performance data – page 115



FEATURES

- Steel construction
- T-bar lay-in
- Perforated face panel only
- White finish

Height	Width			
	12"	24"	36"	48"
12"	X	X		X
24"		X	X	X

T-BAR DIFFUSERS

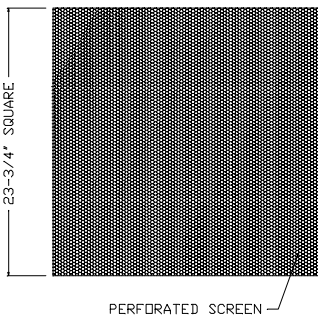



FEATURES

- Steel construction
- 24" x 24" T-bar lay-in
- Perforated face panel
- Concealed hinges and latches
- Accepts 1" disposable filter (not included)
- White finish

MODEL SPRFTB

Perforated Face Filter Grille, T-Bar

STEEL

Performance data – page 115

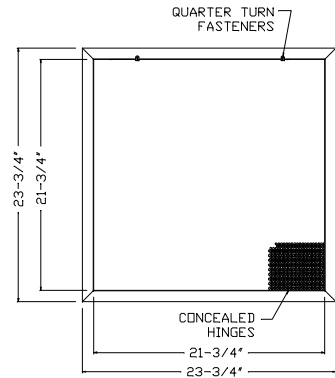

FEATURES

- Steel construction
- 24" x 24" T-bar lay-in
- Perforated face panel
- Concealed hinges and latches
- Accepts 1" disposable filter (not included)
- 5" deep plenum box
- R6 fiberglass back plenum accepts 6" to 18" round spin-in collars (not included)
- White finish

MODEL SPR20F

Perforated Face Filter Grille, T-Bar w/ Plenum Back

STEEL

Performance data – page 115

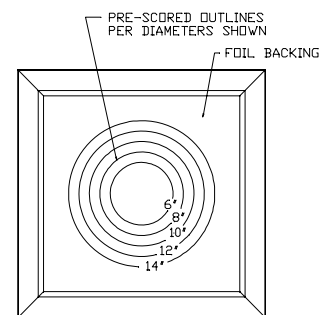
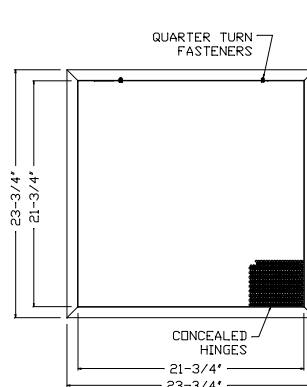

COMMERCIAL

T-BAR DIFFUSERS



MODEL 7500-6

Perforated Supply Diffuser w/ Pattern Deflectors, Removable Face, Steel Back, T-Bar

STEEL

Performance data – page 115

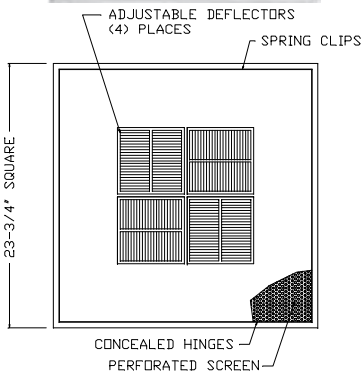

FEATURES

- Steel construction
- 24" x 24" T-bar lay-in
- Perforated steel face
- Steel back panel
- Concealed hinges and latches
- Includes adjustable pattern deflectors on back of face panel
- Includes integral collar to accept Model BDS or RDS dampers
- White finish (optional black finish on back panel)

Module	Diameter				
	6"	8"	10"	12"	14"
24x24	X	X	X	X	X

COMMERCIAL

MODEL 7500R-6

Perforated Return Diffuser, Removable Face, Steel Back, T-Bar

STEEL

Performance data – page 115

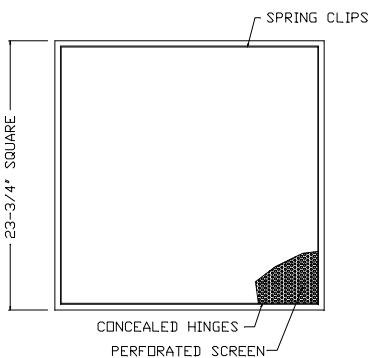

FEATURES

- Steel construction
- 24" x 24" T-bar lay-in
- Perforated steel face
- Steel back panel
- Concealed hinges and latches
- Includes integral collar to accept Model BDS or RDS dampers
- White finish (optional black finish on back panel)

Module	Diameter				
	6"	8"	10"	12"	14"
24x24	X	X	X	X	X

T-BAR DIFFUSERS



FEATURES

- Steel construction
- 24" x 24" T-bar lay-in
- Perforated steel face
- Steel back panel
- Concealed hinges and latches
- Square collar
- White finish (optional black finish on back panel)

Module	Neck Size							
	6"x6"	8"x8"	10"x10"	12"x12"	14"x14"	16"x16"	18"x18"	22"x22"
24x24	X	X	X	X	X	X	X	X

MODEL 7550R-6

Perforated Return Diffuser, Removable Face, Square Neck, Steel Back, T-Bar

STEEL

Performance data – page 115

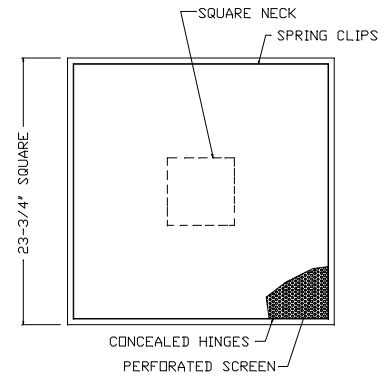

COMMERCIAL

T-BAR DIFFUSERS



MODEL 7600-6

**Curved Blade Perforated Supply,
Removable Face, Steel Back, T-Bar**

STEEL

Performance data – page 115

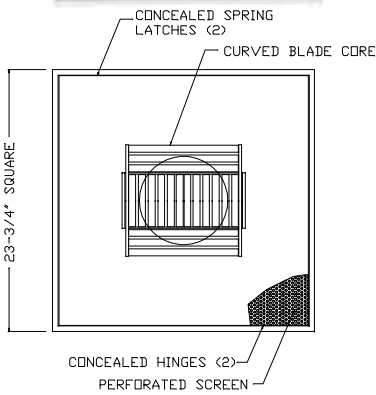

FEATURES

- Steel construction
- 24" x 24" T-bar lay-in
- Perforated steel face
- Steel back panel
- Concealed hinges and latches
- Includes adjustable curved blade pattern deflectors attached to back panel
- Includes integral collar to accept Model BDS or RDS dampers
- White finish (optional black finish on back panel)

Module	Diameter				
	6"	8"	10"	12"	14"
24x24	X	X	X	X	X

COMMERCIAL

MODEL 7600R-6

**Perforated Return, Removable Face,
Steel Back, T-Bar**

STEEL

Performance data – page 115

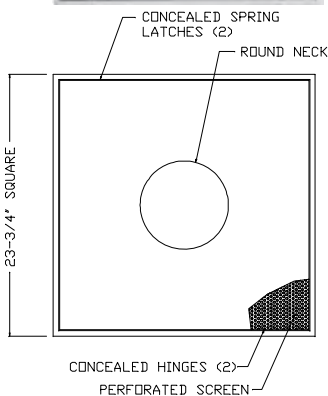

FEATURES

- Steel construction
- 24" x 24" T-bar lay-in
- Perforated steel face
- Steel back panel
- Concealed hinges and latches
- Includes integral collar to accept Model BDS or RDS dampers
- White finish (optional black finish on back panel)

Module	Diameter				
	6"	8"	10"	12"	14"
24x24	X	X	X	X	X

T-BAR DIFFUSERS

FEATURES

- Steel construction
- 24" x 24" T-bar lay-in
- 2 cone fixed design
- High capacity performance
- 2" standard inlet collar with integral bead
- 360 degree air pattern
- Removable center plug for damper access
- White finish

Module	Diameter				
	6"	8"	10"	12"	14"
24x24	X	X	X	X	X

MODEL 4700-6
Step Down Ceiling Diffuser, 2 Cone, T-Bar

STEEL

Performance data – page 109

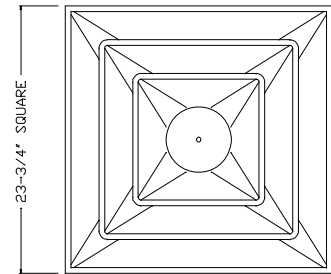
FEATURES

- Steel construction
- 24" x 24" T-bar lay-in
- 2 cone fixed design
- High capacity performance
- 2" standard inlet collar with integral bead
- 360 degree air pattern
- Includes Model BDS damper
- Removable center plug for damper access
- White finish

Module	Diameter				
	6"	8"	10"	12"	14"
24x24	X	X	X	X	X

MODEL 4700D-6
Step Down Ceiling Diffuser, 2 Cone, w/ Damper, T-Bar

STEEL

Performance data – page 109

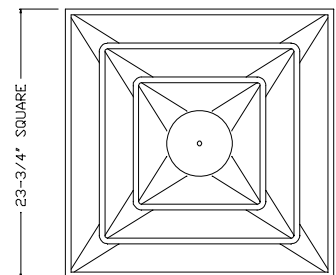



MODEL 4706-6

Step Down Ceiling Diffuser, 2 Cone, w/R6 Molded Back, T-Bar

STEEL

Performance data – page 109



- FEATURES
- Steel construction
- 24" x 24" T-bar lay-in
- 2 cone fixed design
- High capacity performance
- 2" standard inlet collar with integral bead
- 360 degree air pattern
- Removable center plug for damper access
- Includes R6 molded fiberglass back
- White finish

Module	Diameter				
	6"	8"	10"	12"	14"
24x24	X	X	X	X	X

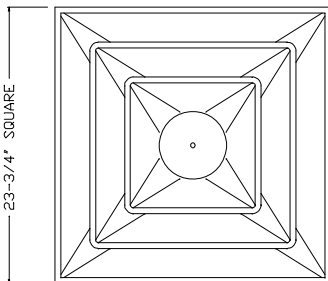

COMMERCIAL

MODEL 4706D-6

Step Down Ceiling Diffuser, 2 Cone, w/R6 Molded Back, w/Damper, T-Bar

STEEL

Performance data – page 109



- FEATURES
- Steel construction
- 24" x 24" T-bar lay-in
- 2 cone fixed design
- High capacity performance
- 2" standard inlet collar with integral bead
- 360 degree air pattern
- Includes Model BDS damper
- Includes R6 molded fiberglass back
- Removable center plug for damper access
- White finish

Module	Diameter				
	6"	8"	10"	12"	14"
24x24	X	X	X	X	X

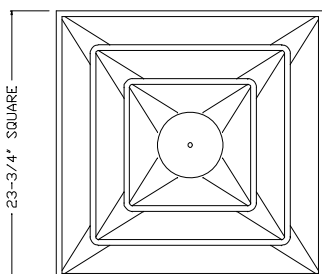

T-BAR DIFFUSERS

FEATURES

- Steel construction
- 24" x 24" T-bar lay-in
- Plaque panel design
- High capacity performance
- 2" standard inlet collar with integral bead
- 360 degree air pattern
- Removable panel
- White finish

Module	Diameter				
	6"	8"	10"	12"	14"
24x24	X	X	X	X	X

MODEL 4750-6
Plaque Panel Ceiling Diffuser, T-Bar
STEEL

Performance data – page 109

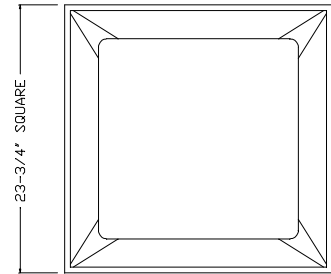

FEATURES

- Steel construction
- 24" x 24" T-bar lay-in
- Plaque panel design
- High capacity performance
- 2" standard inlet collar with integral bead
- 360 degree air pattern
- Includes Model BDS damper
- Removable panel
- White finish

Module	Diameter				
	6"	8"	10"	12"	14"
24x24	X	X	X	X	X

MODEL 4750D-6
Plaque Panel Ceiling Diffuser w/Damper, T-Bar
STEEL

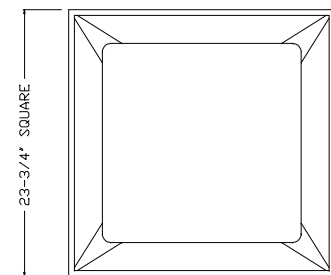
Performance data – page 109



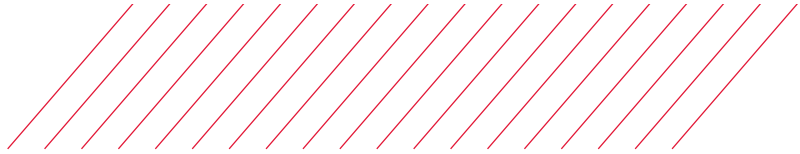

MODEL 4756-6

**Plaque Panel Ceiling Diffuser
w/R6 Molded Back, T-Bar**

STEEL

Performance data – page 109



FEATURES

- Steel construction
- 24" x 24" T-bar lay-in
- Plaque panel design
- High capacity performance
- 2" standard inlet collar with integral bead
- 360 degree air pattern
- Includes R6 molded fiberglass back
- Removable panel
- White finish

Module	Diameter				
	6"	8"	10"	12"	14"
24x24	X	X	X	X	X

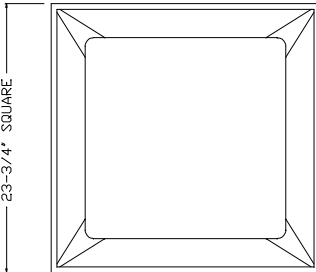

COMMERCIAL

MODEL 4756D-6

**Plaque Panel Ceiling Diffuser
w/R6 Molded Back, Damper, T-Bar**

STEEL

Performance data – page 109



FEATURES

- Steel construction
- 24" x 24" T-bar lay-in
- Plaque panel design
- High capacity performance
- 2" standard inlet collar with integral bead
- 360 degree air pattern
- Includes Model BDS damper
- Includes R6 molded fiberglass back
- Removable panel
- White finish

Module	Diameter				
	6"	8"	10"	12"	14"
24x24	X	X	X	X	X

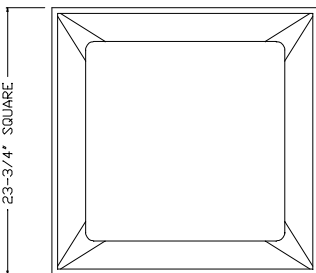

T-BAR DIFFUSERS



FEATURES

- Steel construction
- 24" x 24" T-bar lay-in
- 3 cone fixed design
- High capacity performance
- 2" standard inlet collar with integral bead
- 360 degree air pattern picture
- Removable center plug for damper access
- White finish

		Diameter				
Module	6"	8"	10"	12"	14"	
24x24	X	X	X	X	X	

MODEL 4800-6

Step Down Ceiling Diffuser, 3 Cone, T-Bar

STEEL

Performance data – page 109

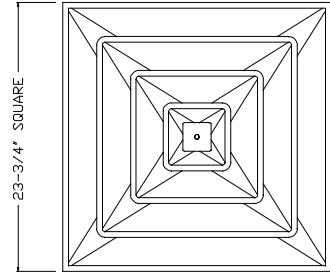

FEATURES

- Steel construction
- 24" x 24" T-bar lay-in
- 3 cone fixed design
- High capacity performance
- 2" standard inlet collar with integral bead
- 360 degree air pattern
- Includes Model BDS damper
- Removable center plug for damper access
- White finish

		Diameter				
Module	6"	8"	10"	12"	14"	
24x24	X	X	X	X	X	

MODEL 4800D-6

Step Down Ceiling Diffuser, 3 Cone w/ Damper, T-Bar

STEEL

Performance data – page 109

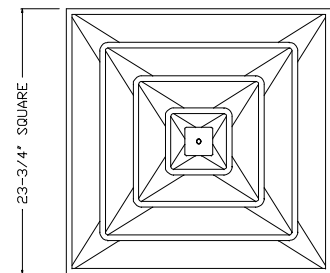

COMMERCIAL

T-BAR DIFFUSERS

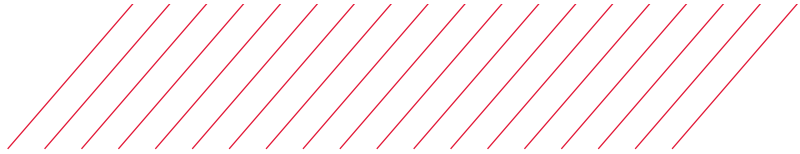

MODEL 4806-6

Step Down Ceiling Diffuser, 3 Cone, w/R6 Molded Back, T-Bar

STEEL

Performance data – page 109

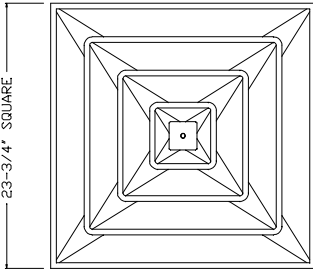

FEATURES

- Steel construction
- 24" x 24" T-bar lay-in
- 3 cone fixed design
- High capacity performance
- 2" standard inlet collar with integral bead
- 360 degree air pattern
- Removable center plug for damper access
- Includes R6 molded fiberglass back
- White finish

Module	Diameter				
	6"	8"	10"	12"	14"
24x24	X	X	X	X	X

COMMERCIAL

MODEL 4806D-6

Step Down Ceiling Diffuser, 3 Cone, w/R6 Molded Back, Damper, T-Bar

STEEL

Performance data – page 109

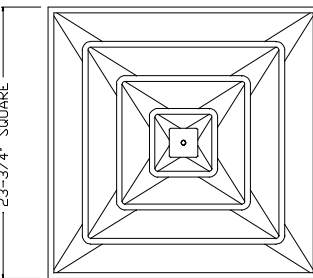

FEATURES

- Steel construction
- 24" x 24" T-bar lay-in
- 3 cone fixed design
- High capacity performance
- 2" standard inlet collar with integral bead
- 360 degree air pattern
- Includes Model BDS damper
- Includes R6 molded fiberglass back
- Removable center plug for damper access
- White finish

Module	Diameter				
	6"	8"	10"	12"	14"
24x24	X	X	X	X	X

T-BAR DIFFUSERS

FEATURES

- Steel construction
- 24" x 24" T-bar lay-in
- 2 cone fixed design
- High capacity performance
- Includes R6 molded fiberglass back
- Accepts 6" to 15" spin-in collar (by others)
- Accepts Snap-59 collar (order separately)
- 360 degree air pattern
- Removable center plug for damper access
- White finish

MODEL 5906-6

**Step Down Ceiling Diffuser, 2 Cone,
w/R6 Molded Back for Spin-in Collars, T-Bar**

STEEL

Performance data – page 109

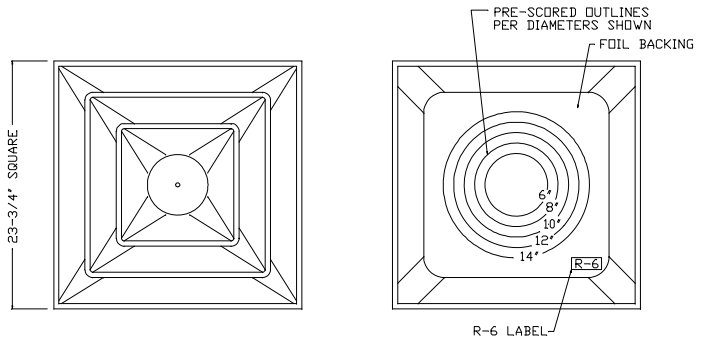
FEATURES

- Steel construction
- 24" x 24" T-bar lay-in
- 3 cone fixed design
- High capacity performance
- Includes R6 molded fiberglass back
- Accepts 6" to 15" spin-in collar (by others)
- Accepts Snap-59 collar (order separately)
- 360 degree air pattern
- Removable center plug for damper access
- White finish

MODEL 5906-3-6

**Step Down Ceiling Diffuser, 3 Cone,
w/R6 Molded Back for Spin-in Collars, T-Bar**

STEEL

Performance data – page 109

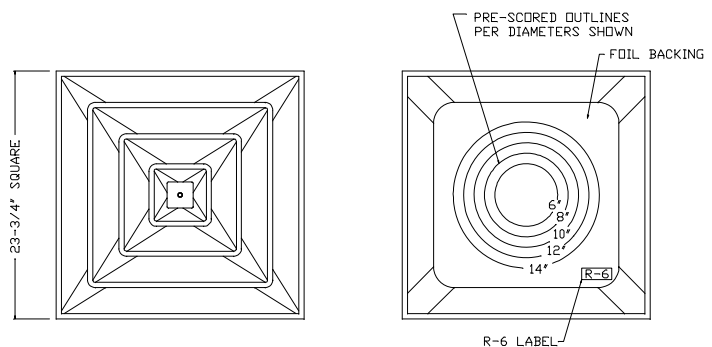

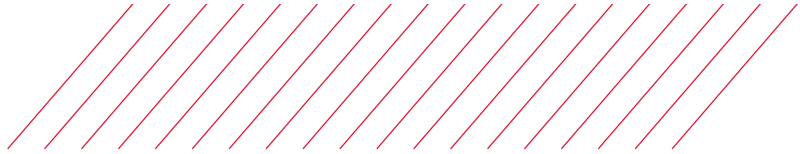

MODEL 5956-6

**Plaque Panel Ceiling Diffuser
w/R6 Molded Back for Spin-in Collars, T-Bar**

STEEL

Performance data – page 109



FEATURES

- Steel construction
- 24" x 24" T-bar lay-in
- Plaque panel design
- High capacity performance
- 360 degree air pattern
- Includes R6 molded fiberglass back
- Removable panel
- Accepts 6" to 15" spin-in collars (by others)
- Accepts Snap-59 collar (order separately)
- White finish

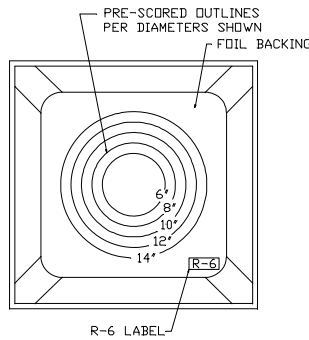
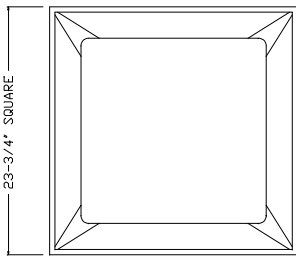

COMMERCIAL

MODEL 4900-6

Square Louver Face Ceiling Diffuser, T-Bar

EXTRUDED ALUMINUM

Performance data – page 116



FEATURES

- Extruded aluminum construction
- 24" x 24" T-bar lay-in
- Louver face design on 12" x 12" or 24" x 24" panel
- High capacity performance
- 360 degree air pattern
- White finish

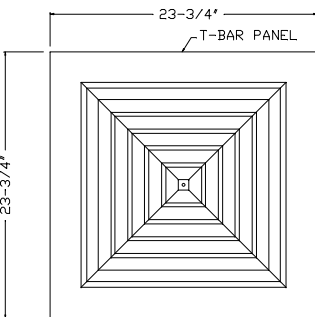
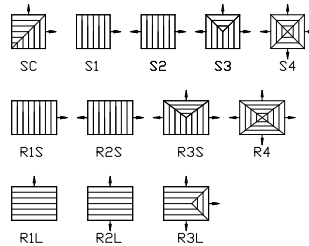

Panel	Height	Width					
		6"	9"	12"	15"	18"	21"
12x12	6"	X					
	9"	X	X				
24x24	12"	X	X	X			
	15"	X	X	X	X		
	18"	X	X	X	X	X	
	21"						X

T-BAR DIFFUSERS

FEATURES

- Extruded aluminum construction
- 24" x 24" T-bar lay-in
- Modular core design
- Removable cores for 1, 2, 3 and 4 way patterns
- White finish

Module	Height	Width							
		6"	8"	10"	12"	14"	16"	18"	20"
12x12	8"		X						
24x24	6"	X							
	8"		X						
	10"			X					
	12"				X				
	14"					X			
	16"						X		
	18"							X	
	20"							X	

MODEL 9000-6
Mod Core Ceiling Diffuser, T-Bar
 EXTRUDED ALUMINUM

Performance data – page 106

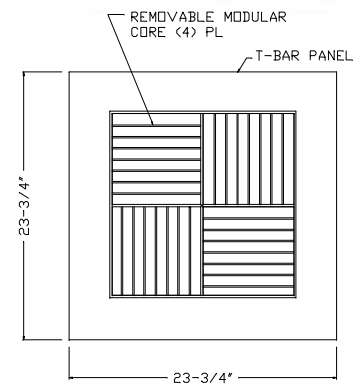

FEATURES

- Steel construction
- 24" x 24" T-bar lay-in
- 4 way louver face design
- 360 degree air pattern
- Includes R6 molded fiberglass back
- Accepts 6" to 15" spin-in collars (by others)
- White finish

MODEL 5500SI-6
Louvered Face Ceiling Diffuser w/R6 Molded Back
 for Spin-in Collars, T-Bar

STEEL

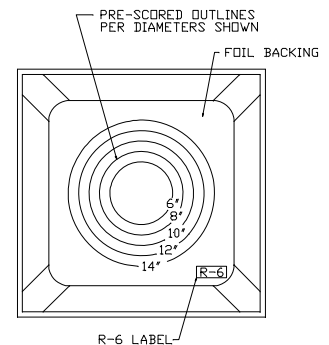
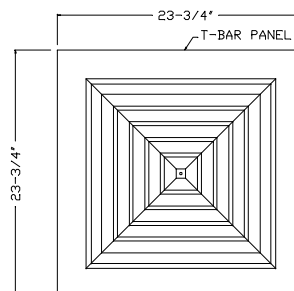
Performance data – page 108





MODEL 5500 DAF-CC5-6

**Concentric Supply/Return Diffuser,
Louver Face – Cube Core, T-Bar**

EXTRUDED ALUMINUM

Performance data – page 108

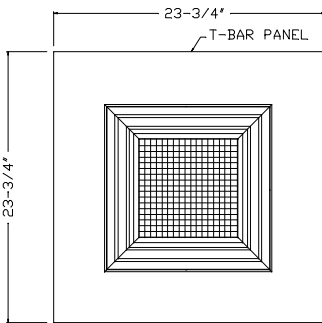

FEATURES

- 1/2 24" x 24" T-bar lay-in
- Extruded aluminum louver outer 4 way supply
- Cube core center snap-in/out return
- White finish
- Supply/return plenums by others

Module	Square Neck Sizes	
	Supply	Return
24x24	12"x12"	9"x9"
	15"x15"	9"x9"
	18"x18"	12"x12"
	18"x18"	15"x15"
	21"x21"	15"x15"
	12"x12"	9"x9"
48x24	15"x15"	9"x9"
	18"x18"	12"x12"
	18"x18"	15"x15"
	24"x24"	18"x18"
	27"x27"	18"x18"
	30"x30"	21"x21"
48x48	33"x33"	21"x21"
	36"x36"	24"x24"
	39"x39"	27"x27"
	42"x42"	27"x27"
	42"x42"	30"x30"
	42"x42"	33"x33"

FEATURES

- Steel construction
- Round panel with 6" to 14" integral neck
- Neck is 1-1/2" high

Diameter				
6"	8"	10"	12"	14"
X	X	X	X	X

MODEL SNAP 59
Snap-in Collar, 1 1/2" high

STEEL

FEATURES

- Steel construction
- Round panel with 6" to 14" integral neck
- Neck is 2" high

Diameter				
6"	8"	10"	12"	14"
X	X	X	X	X

MODEL SNAP 59-2
Snap-in Collar, 2" high

STEEL



FEATURES

- Steel construction
- Center cup that converts 2 cone 4700 to 3 cone

MODEL SNAP 58
Converts 2 Cone Diffuser to 3 Cone

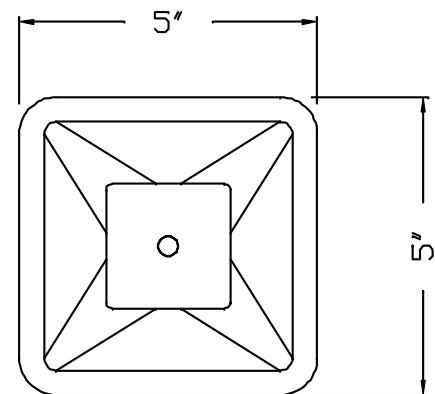
STEEL

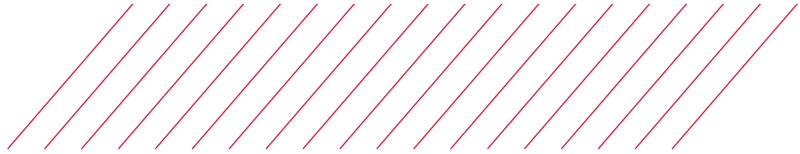



MODEL BDS
Round Butterfly Damper
 STEEL

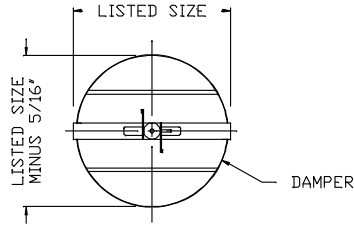

FEATURES

- Steel construction
- Butterfly style damper
- Blades are adjustable through diffuser face
- Includes damper operator
- Clips to top of collars

Diameter				
6"	8"	10"	12"	14"
X	X	X	X	X

COMMERCIAL

MODEL RSD
Radial Shutter Damper
 STEEL

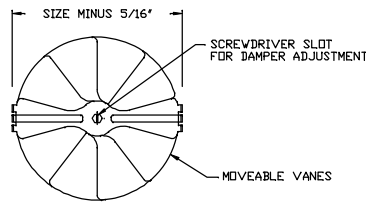

FEATURES

- Steel construction
- Radial shutter style damper
- 5 blades are adjusted through diffuser face
- Screwdriver adjustable
- Clips to top of collars

Diameter			
6"	8"	10"	12"
X	X	X	X

MODEL TBP/STBP
T-Bar Mounting Panel
 ALUMINUM/STEEL

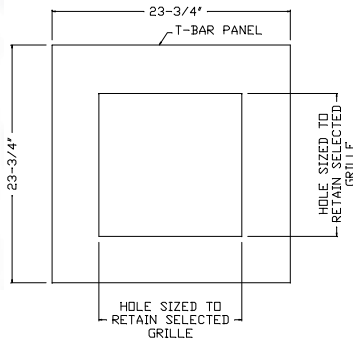

FEATURES

TBP – Aluminum

STBP – Steel

- T-bar mounting panel for grilles, registers and diffusers
- Can also be used as a solid filler panel for T-bar ceiling
- 24" x 24" panel
- Specify required hole size
- White finish

T-BAR ACCESSORIES



FEATURES

TBPF – Aluminum

STBPF – Steel

- Allows for installation of T-bar products in plaster ceilings
- Kit includes screws and angle brackets

Width x Height
12x24
24x24

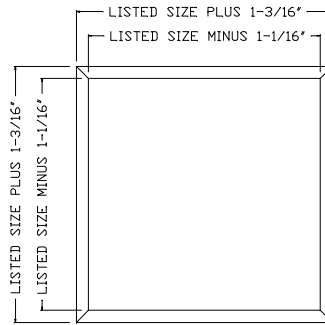

MODEL TBPF/STBPF

Plaster Frame – T-Bar

ALUMINUM/STEEL



FEATURES

- Aluminum construction
- Allows for installation of grilles, registers and diffusers into plaster walls or ceilings
- Designate register size for ordering

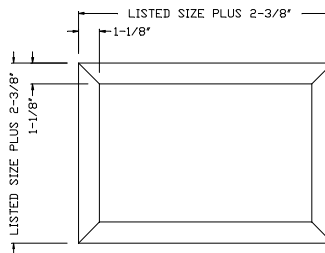

MODEL PF

Plaster Frame – Ceiling/Sidewall

ALUMINUM



FEATURES

- R6 fiberglass insulated back panel
- Foil facing
- Pre-scored for round necks – 6" to 14"

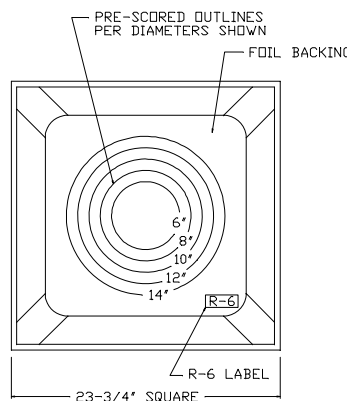

MODEL FGB-R6

R-6 Molded Fiberglass Back

INSULATION





MODEL OBD

Opposed Blade Damper

STEEL

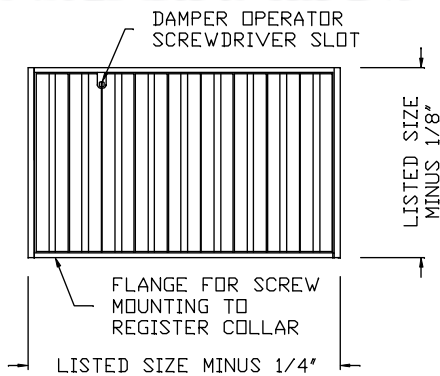

FEATURES

- Steel construction
- Opposed blade damper
- Tapered blades set in U-channel frame
- Screwdriver operated
- Mill finish

Height	Width												
	6"	8"	10"	12"	14"	16"	18"	20"	22"	24"	26"	28"	30"
4"	X	X	X	X	X	X	X	X	X	X	X	X	X
5"	X	X	X	X	X	X	X	X	X	X	X	X	X
6"	X	X	X	X	X	X	X	X	X	X	X	X	X
8"		X	X	X	X	X	X	X	X	X	X	X	X
10"			X	X	X	X	X	X	X	X	X	X	X
12"				X	X	X	X	X	X	X	X	X	X
14"					X	X	X	X	X	X	X	X	X
16"						X	X	X	X	X	X	X	X
18"							X	X	X	X	X	X	X
20"								X	X	X	X	X	X
22"									X	X	X	X	X
24"										X	X	X	X
26"											X	X	X
28"												X	X
30"													X

FEATURES

- Aluminum construction
- Opposed blade damper
- Double wall blades set in U-channel frame
- Blades set on 1-1/2" centers
- Snaps easily on selected USAIRE grilles
- Screwdriver operated
- Mill finish

Height	Width												
	6"	8"	10"	12"	14"	16"	18"	20"	22"	24"	26"	28"	30"
4"	X	X	X	X	X	X	X	X	X	X	X	X	X
5"	X	X	X	X	X	X	X	X	X	X	X	X	X
6"	X	X	X	X	X	X	X	X	X	X	X	X	X
8"		X	X	X	X	X	X	X	X	X	X	X	X
10"			X	X	X	X	X	X	X	X	X	X	X
12"				X	X	X	X	X	X	X	X	X	X
14"					X	X	X	X	X	X	X	X	X
16"						X	X	X	X	X	X	X	X
18"							X	X	X	X	X	X	X
20"								X	X	X	X	X	X
22"									X	X	X	X	X
24"										X	X	X	X
26"											X	X	X
28"												X	X
30"													X

MODEL OBDA

Opposed Blade Damper

ALUMINUM

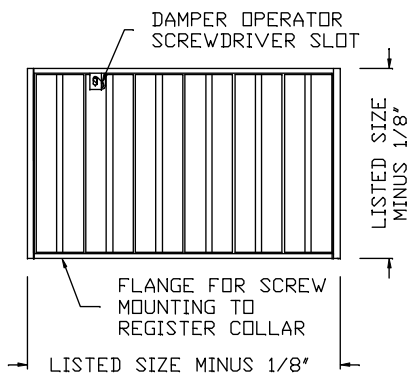

FEATURES

- Steel construction
- Converts square neck to round neck
- Box is 1-9/16" deep
- Round neck height is 1-1/8"

Square Neck Size	Round Duct Size												
	5"	6"	7"	8"	9"	10"	11"	12"	14"	15"	16"	18"	
6"x6"	X	X											
8"x8"	X	X	X	X									
9"x9"	X	X	X	X	X								
10"x10"	X	X	X	X	X	X							
12"x12"	X	X	X	X	X	X	X	X					
14"x14"	X	X	X	X	X	X	X	X	X				
15"x15"	X	X	X	X	X	X	X	X	X	X			
16"x16"	X	X	X	X	X	X	X	X	X	X	X		
18"x18"	X	X	X	X	X	X	X	X	X	X	X	X	

MODEL TR

Square to Round Transition, 1-1/8" Neck
STEEL

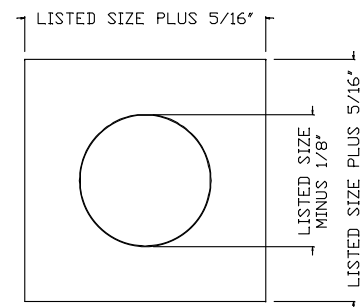

FEATURES

- Steel construction
- Converts square neck to round neck
- Box is 3" deep
- Round neck height is 1-7/8"

Square Neck Size	Round Duct Size												
	5"	6"	7"	8"	9"	10"	11"	12"	14"	15"	16"	18"	
6"x6"	X	X											
8"x8"	X	X	X	X									
9"x9"	X	X	X	X	X								
10"x10"	X	X	X	X	X	X							
12"x12"	X	X	X	X	X	X	X	X					
14"x14"	X	X	X	X	X	X	X	X	X				
15"x15"	X	X	X	X	X	X	X	X	X	X			
16"x16"	X	X	X	X	X	X	X	X	X	X	X		
18"x18"	X	X	X	X	X	X	X	X	X	X	X	X	

MODEL TRD

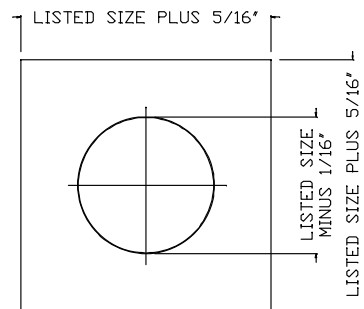
Square to Round Transition, 1-7/8" Neck Height, 3" Deep Box
STEEL



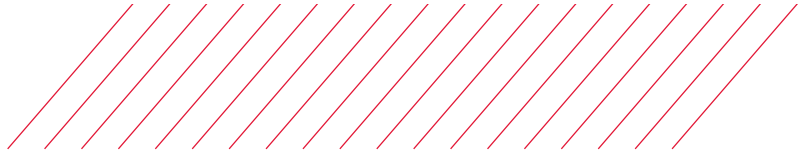

UL FIRE DAMPERS

Fire Dampers are used to prevent transmission of flame where air ducts and transfers penetrate fire barriers.

The basic standard used to evaluate fire dampers is the Standard for Fire Dampers, UL 555. Dampers certified by UL carry an hourly fire resistance rating, usually 1-1/2 or 3 hours.

Fire dampers are available in two types: static fire dampers and dynamic fire dampers:

Static Rated

- Used in duct systems or penetrations where there is no (or negligible) airflow when the damper closes. (Fans off during a fire)



Dynamic Rated

- Required at locations in which fan pressure will be on during a fire incident, and are expected to be able to operate (close) against the air velocity and pressure produced by the system fan. Fire dampers for use in dynamic systems are provided with an airflow rating which indicates the maximum velocity and static pressure that the damper is designed for. (Fans on during a fire)

NFPA 90A defines what damper hourly rating to use. It states that:

- Fire dampers used for the protection of openings in walls, partitions, or floors with fire resistance ratings of less than 3 hours shall have a 1-1/2 hour fire protection rating.
- Fire dampers used for the protection of openings in walls, partitions, or floors having a fire resistance rating of 3 hours or more shall have a 3 hour fire protection rating.



Stainless Steel Closure Spring



Fire Dampers are intended for either vertical or horizontal mount. The mounting direction is based upon the orientation of the DAMPER, and is therefore the opposite of the duct.

- Vertical mount dampers are for wall penetrations only. (They would connect to horizontal ducts)
- Horizontal mount dampers are spring loaded. Typically, they may be installed in floors or walls. (They would install into vertical ducts)

All UL-listed dampers are provided with UL-approved installation instructions. The specific damper's installation instructions must be followed in order to maintain the UL listing of the damper.



DAMPER SLEEVES

In order to be legally installed, fire dampers normally need to be mounted into a sleeve. If the damper frame is of sufficient depth and gauge, it can act as the damper sleeve (known as integral sleeve dampers – see the S series).

The required gauge of the sleeve depends upon the duct connection method:

- Rigid connections require heavy gauge sleeves (16ga and in some cases 14ga).
- Duct gauge sleeves can be used when using a UL-approved breakaway joint for duct connection.

Damper sleeves can be field or factory supplied and still comply with UL installations.

RETAINING ANGLES

Fire dampers must be installed using retaining angles. Retaining angles are attached to the fire damper sleeve, typically on both sides of the wall or floor, in order to hold the fire damper in place. The angles serve a second purpose of covering the required expansion gap between the fire damper and the wall or floor it is installed in. As with the damper sleeve, retaining angles can be factory or field supplied.

DAMPER CONFIGURATIONS

Standard industry terminology for curtain fire damper sizing and transitions, as published by SMACNA are:

- Type A – Damper blades and damper frame are in the airstream.
- Type B – Damper is oversized in height to remove blades from airstream; damper frame on sides and bottom are in the airstream.
- Type C – Damper is oversized in width and height to remove blades and frame from airstream to achieve 100% free area. Done through the use of transitions fitted to the damper or damper sleeve.

C is a rectangular to rectangular transition

CR is a rectangular to round transition (for use with round ductwork)

CO is a rectangular to oval transition (for use with flat oval ductwork)

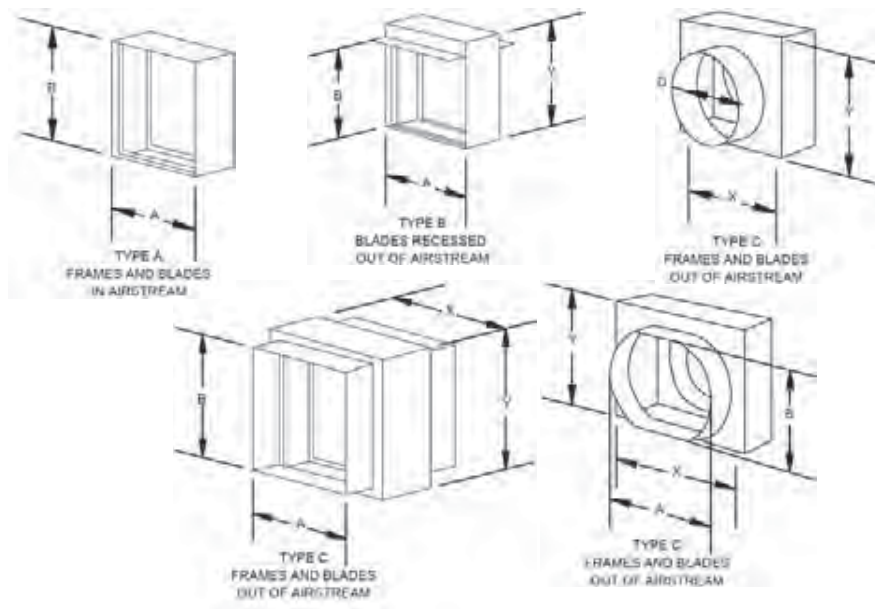

In all cases, the damper is ordered by the duct dimensions, where 'A' is the duct width and 'B' is the duct height. The values 'X' and 'Y' vary by product and must be confirmed on the product submittal sheet to verify overall damper size.

Unless otherwise noted, all dampers are provided 1/4" undercut from ordered dimensions.

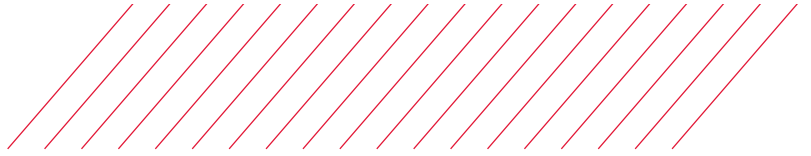

CEILING RADIATION DAMPERS

Ceiling dampers, also known as radiation dampers, are used to limit the passage of heat – not flame. They are applied in fire resistive floor-ceiling or roof-ceiling assemblies where ducts or other HVAC penetrations are made only through the ceiling membrane of the fire resistive assembly.

The basic standard used to evaluate fire dampers is the Standard for Ceiling Dampers, UL 555C. Dampers certified by UL carry an hourly fire resistance rating that is normally tied to the floor/ceiling or roof/ceiling assembly – from as little as 1 hour and in rare cases up to 4 hours.

Based upon the fact that ceiling dampers are only used to protect ceiling penetrations, they will always be for horizontal mount.

Ceiling dampers are installed in or on the neck of a grille or diffuser at the rated ceiling. In some instances they are also installed in steel duct drop above the opening being protected. Ceiling dampers should not be used behind wall or floor grilles.

All UL listed dampers are provided with UL-approved installation instructions. The specific damper's installation instructions must be followed in order to maintain the UL listing of the damper.





FEATURES

- Galvanized steel frame and blade
- 1/4" square plated, steel axles
- Locking quadrant included
- Provided 1/8" under duct size
- Not recommended for motor operation
- Maximum recommended velocity: 1500 fpm

Sizes
6", 8", 10", 12", 14", 16"

Listed sizes are width by height.
Contact factory for sizes exceeding published limits.

MODEL PBD-20 RS
True Round Manual Balancing Damper

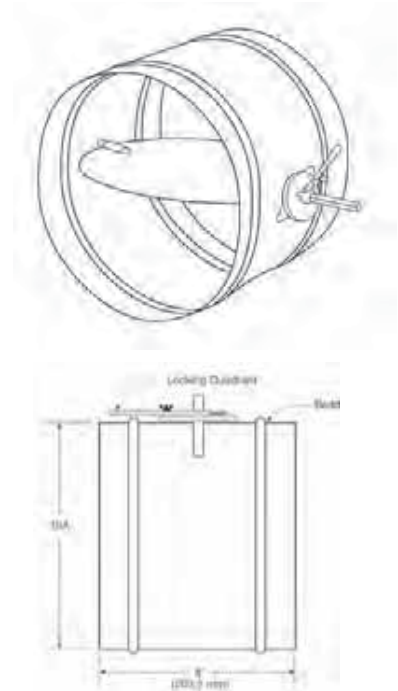

BALANCING DAMPERS

FEATURES

- Galvanized steel frame and blade
- 1/4" square plated, steel axles
- Locking quadrant included
- Provided 1/4" under duct size
- Not recommended for motor operation
- Damper blade must run horizontally
- Maximum recommended velocity: 1500 fpm
- SMACNA compliant

Sizes
6"x6", 8"x8", 10"x10", 12"x12"

Listed sizes are width by height.
Contact factory for sizes exceeding published limits.

MODEL PBD-20
Square Manual Balancing Damper

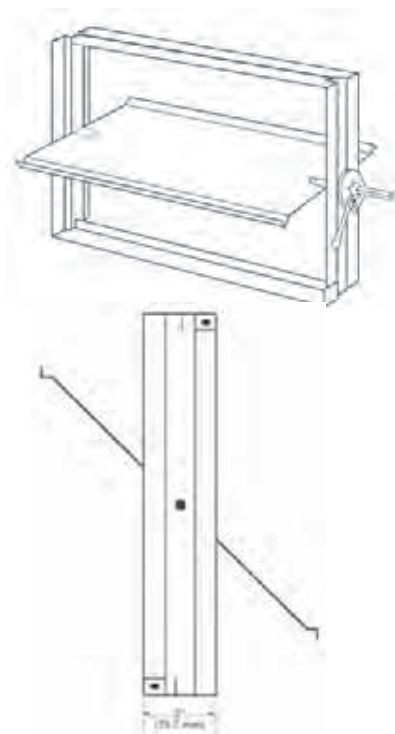

DAMPERS & LOUVERS

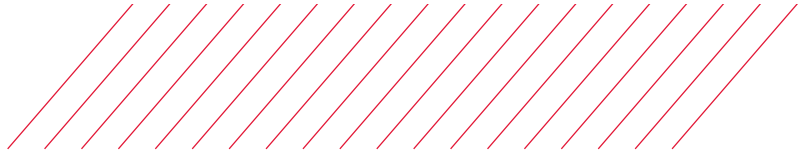

MODEL XABD-2

Extruded Aluminum Backdraft Damper

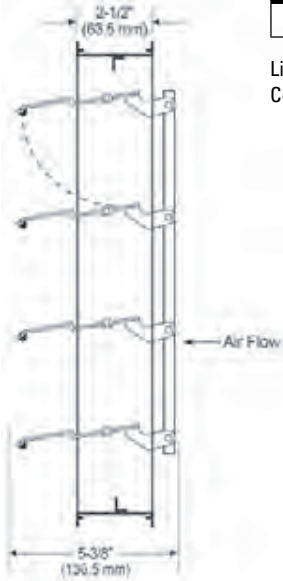
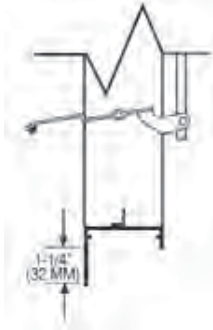

FEATURES

- Extruded aluminum frame and blades
- Nylon bearings and axles
- Maximum velocity: 2500 fpm
- Flange frame available (front or rear flange)

Minimum Size	Maximum Size
6" x 6"	40" x 52"

Listed sizes are width by height.
Contact factory for sizes exceeding published limits.

FEATURES

- Extruded aluminum frame and blades
- Flattened expanded aluminum birdscreen standard, insect screen optional
- Blades fixed at 45 angle
- Provided 1/4" under ordered size
- Standard mill finish aluminum (finish options are available)
- Flange frame available (optional)
- Ideal for exhaust air applications

Minimum Size	Maximum Size
8" x 12"	96" x 96"

Listed sizes are width by height.
Contact factory for sizes exceeding published limits.

MODEL XAJ-4-GL

Straight Blade Air Louver



FEATURES

- Extruded aluminum frame and blades
- Flattened expanded aluminum birdscreen standard, insect screen optional
- Blades fixed at 45 angle
- Provided 1/4" under ordered size
- Standard mill finish aluminum (finish options are available)
- Flange frame available (optional)
- Typically used for intake air
- Maximum recommend velocity: 600 fpm

Minimum Size	Maximum Size
12" x 12"	96" x 96"

Listed sizes are width by height.
Contact factory for sizes exceeding published limits.

MODEL XAD-4-45-GL

Drainable Blade Air Louver



MODEL FD-A

1-1/2 Hour, Type A Static Fire Damper

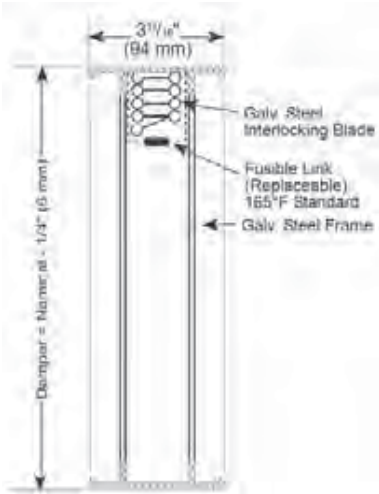

FEATURES

- Roll-formed galvanized steel frame and blades
- Available in vertical (V) or horizontal (H) models
- Stainless steel closure spring (horizontal models only)
- Provided 1/4" under duct size
- Provided with UL-listed fusible link (165°F standard, 212°F optional)
- Meets UL 555 and NFPA requirements

Damper Mounting	Minimum Size	Maximum Single Section Size
Vertical	4" x 4"	60" x 60"
Horizontal	4" x 4"	40" x 40"

Listed sizes are width by height.
Contact factory for sizes exceeding published limits.

MODEL FD-A-SL

1-1/2 Hour, Slimline Static Fire Damper

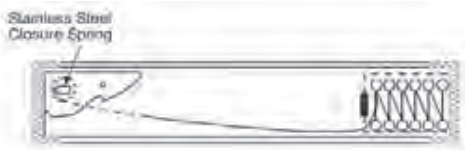
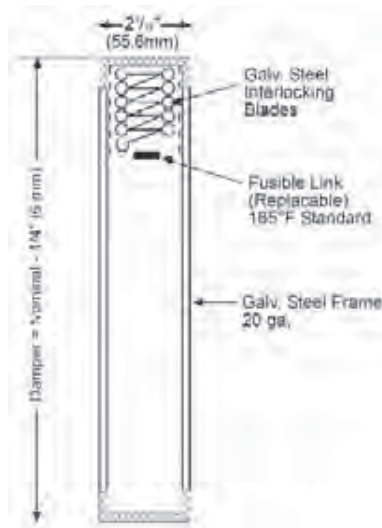

FEATURES

- Roll-formed galvanized steel frame and blades
- Available in vertical (V) or horizontal (H) models
- Stainless steel closure spring (horizontal models only)
- Provided 1/4" under duct size
- Provided with UL-listed fusible link (165°F standard, 212°F optional)
- Meets UL 555 and NFPA requirements

Damper Mounting	Minimum Size	Maximum Single Section Size
Vertical	4" x 4"	60" x 60"
Horizontal	4" x 4"	40" x 40"

Listed sizes are width by height.
Contact factory for sizes exceeding published limits.

FEATURES

- Roll-formed galvanized steel frame and blades
- Available in vertical (V) or horizontal (H) models
- Stainless steel closure spring (horizontal models only)
- Provided 1/4" under duct size
- Provided with UL-listed fusible link (165°F standard, 212°F optional)
- Meets UL 555 and NFPA requirements

Damper Mounting	Minimum Size	Maximum Single Section Size
Vertical	4" x 3"	60" x 55"
Horizontal	4" x 3"	40" x 36"

Listed sizes are width by height.
Contact factory for sizes exceeding published limits.

See damper sizing chart for damper oversize allowance.

MODEL FD-B

1-1/2 Hour, Type B Static Fire Damper

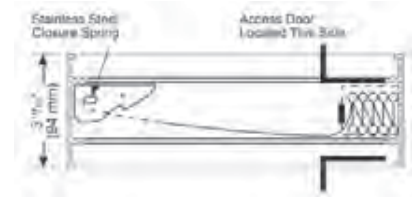
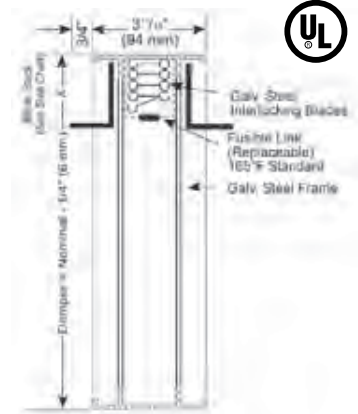

MODEL FD-C

1-1/2 Hour, Type C Static Fire Damper

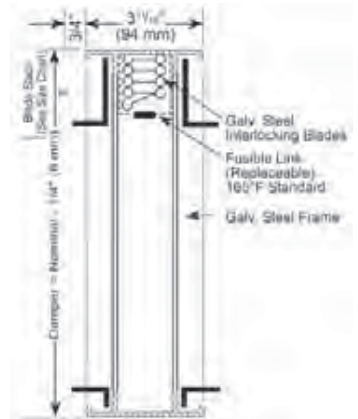

FEATURES

- Roll-formed galvanized steel frame and blades
- Available in vertical (V) or horizontal (H) models
- Stainless steel closure spring (horizontal models only)
- Provided 1/4" under duct size
- Provided with UL-listed fusible link (165°F standard, 212°F optional)
- Meets UL 555 and NFPA requirements
- Available with square to square, square to round or square to oval connections

Damper Mounting	Minimum Size	Maximum Single Section Size
Vertical	3" x 3"	59" x 54"
Horizontal	3" x 3"	39" x 35"

Listed sizes are width by height.
Contact factory for sizes exceeding published limits.

See damper sizing chart for damper oversize allowance.

Minimum round connection size is 4" diameter.

MODEL FD-A-S

1-1/2 Hour, Type A Static Fire Damper w/Integral Sleeve

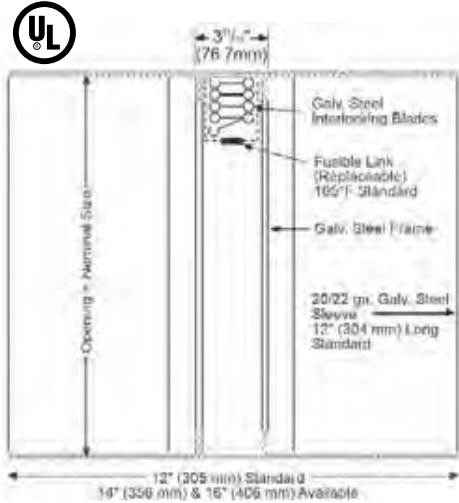

FEATURES

- Roll-formed galvanized steel frame and blades
- Available in vertical (V) or horizontal (H) models
- Stainless steel closure spring (horizontal models only)
- Provided 1/4" under duct size
- Provided with UL-listed fusible link (165°F standard, 212°F optional)
- Meets UL 555 and NFPA requirements

Damper Mounting	Minimum Size	Maximum Single Section Size
Vertical	6" x 6"	48" x 48"
Horizontal	6" x 6"	40" x 40"

Listed sizes are width by height. Contact factory for sizes exceeding published limits.

MODEL FD-B-S

1-1/2 Hour, Type B Static Fire Damper w/Integral Sleeve

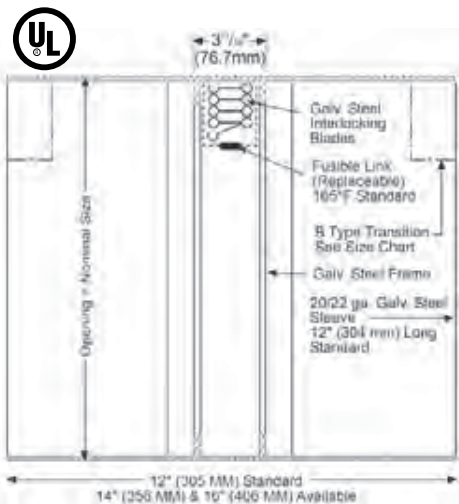

FEATURES

- Roll-formed galvanized steel frame and blades
- Available in vertical (V) or horizontal (H) models
- Stainless steel closure spring (horizontal models only)
- Provided 1/4" under duct size
- Provided with UL-listed fusible link (165°F standard, 212°F optional)
- Meets UL 555 and NFPA requirements

Damper Mounting	Minimum Size	Maximum Single Section Size
Vertical	6" x 3"	48" x 43"
Horizontal	6" x 3"	40" x 36"

Listed sizes are width by height. Contact factory for sizes exceeding published limits.

See damper sizing chart for damper oversize allowance.



FEATURES

- Roll-formed galvanized steel frame and blades
- Available in vertical (V) or horizontal (H) models
- Stainless steel closure spring (horizontal models only)
- Provided 1/4" under duct size
- Provided with UL-listed fusible link (165°F standard, 212°F optional)
- Meets UL 555 and NFPA requirements
- Available with square to square, square to round or square to oval connections

Damper Mounting	Minimum Size	Maximum Single Section Size
Vertical	4" x 3"	47" x 42"
Horizontal	4" x 3"	39" x 35"

Listed sizes are width by height.
Contact factory for sizes exceeding published limits.

See damper sizing chart for damper oversize allowance.

Minimum round connection size is 4" diameter.

MODEL FD-C-S

**1-1/2 Hour, Type C Static Fire Damper
w/Integral Sleeve and Transitions**

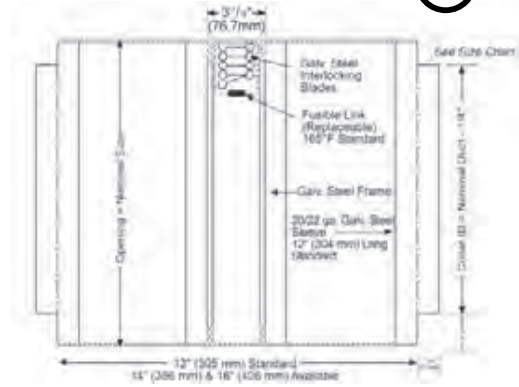

INTEGRAL SLEEVE STATIC FIRE DAMPERS

DAMPERS & LOUVERS

MODEL FDD-A

1-1/2 Hour, Type A Dynamic Fire Damper

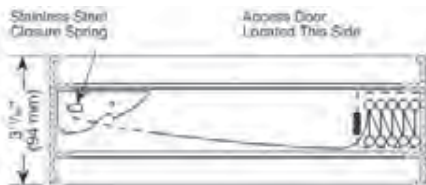
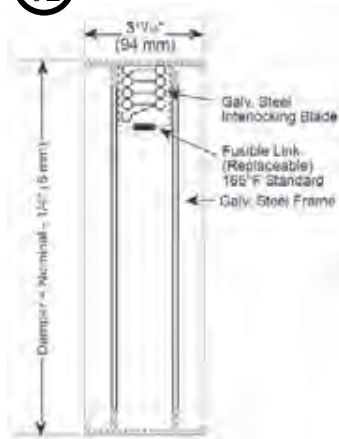

FEATURES

- Roll-formed galvanized steel frame and blades
- Available in vertical (V) or horizontal (H) models
- Stainless steel closure spring
- Provided 1/4" under duct size
- Provided with UL-listed fusible link (165°F standard, 212°F optional)
- Meets UL 555 and NFPA requirements

Damper Mounting	Minimum Size	Maximum Single Section Size
Vertical	6" x 6"	36" x 36"
Horizontal	6" x 6"	24" x 24"

Listed sizes are width by height.
Contact factory for sizes exceeding published limits.

MODEL FDD-A-SL

1-1/2 Hour, Slimline Dynamic Fire Damper

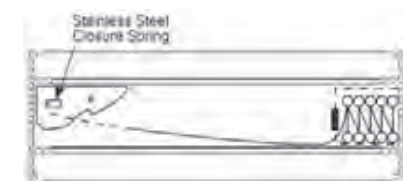
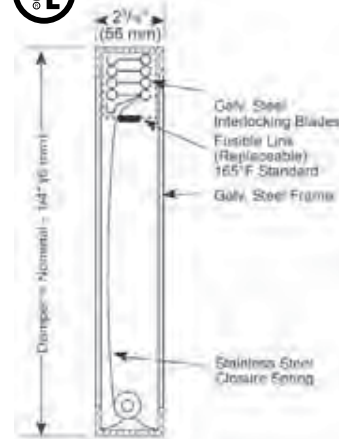

FEATURES

- Roll-formed galvanized steel frame and blades
- Available in vertical (V) or horizontal (H) models
- Stainless steel closure spring
- Provided 1/4" under duct size
- Provided with UL-listed fusible link (165°F standard, 212°F optional)
- Meets UL 555 and NFPA requirements

Damper Mounting	Minimum Size	Maximum Single Section Size
Vertical	6" x 6"	36" x 36"
Horizontal	6" x 6"	24" x 24"

Listed sizes are width by height.
Contact factory for sizes exceeding published limits.

FEATURES

- Roll-formed galvanized steel frame and blades
- Available in vertical (V) or horizontal (H) models
- Stainless steel closure spring
- Provided 1/4" under duct size
- Provided with UL-listed fusible link (165°F standard, 212°F optional)
- Meets UL 555 and NFPA requirements

Damper Mounting	Minimum Size	Maximum Single Section Size
Vertical	6" x 4"	36" x 32"
Horizontal	6" x 4"	24" x 21"

Listed sizes are width by height.

Contact factory for sizes exceeding published limits.

See damper sizing chart for damper oversize allowance.

FEATURES

- Roll-formed galvanized steel frame and blades
- Available in vertical (V) or horizontal (H) models
- Stainless steel closure spring
- Provided 1/4" under duct size
- Provided with UL-listed fusible link (165°F standard, 212°F optional)
- Meets UL 555 and NFPA requirements
- Available with square to square, square to round or square to oval connections

Damper Mounting	Minimum Size	Maximum Single Section Size
Vertical	5" x 3"	35" x 31"
Horizontal	5" x 3"	23" x 20"

Listed sizes are width by height.

Contact factory for sizes exceeding published limits.

See damper sizing chart for damper oversize allowance.

Minimum round connection size is 4" diameter.

MODEL FDD-B

1-1/2 Hour, Type B Dynamic Fire Damper

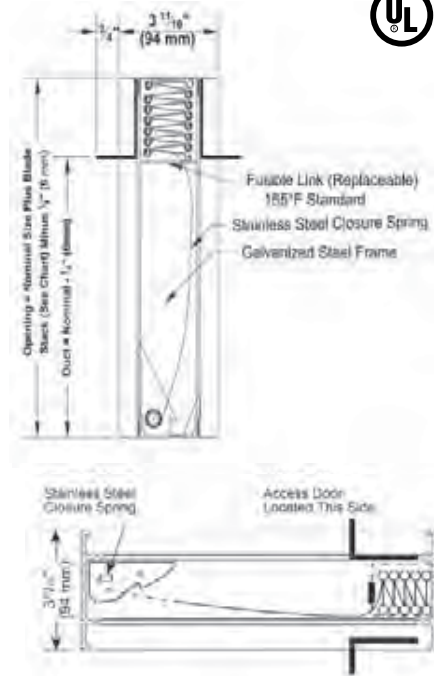

MODEL FDD-C

1-1/2 Hour, Type C Dynamic Fire Damper

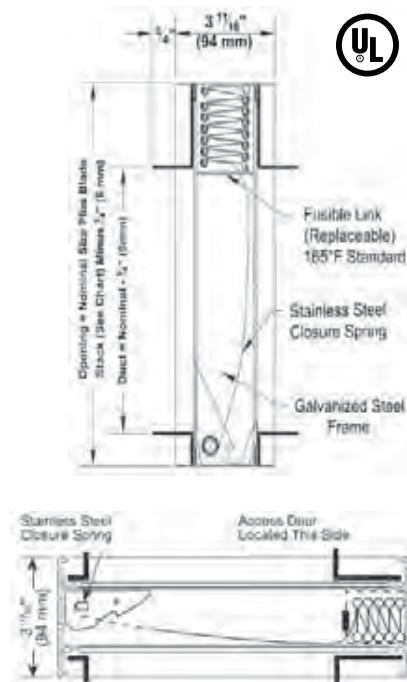



MODEL FDD-A-S

1-1/2 Hour, Type A Dynamic Fire Damper w/Integral Sleeve

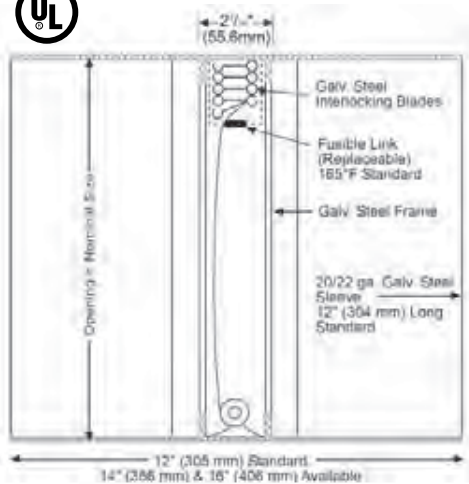

FEATURES

- Roll-formed galvanized steel frame and blades
- Available in vertical (V) or horizontal (H) models
- Stainless steel closure spring
- Provided 1/4" under duct size
- Provided with UL-listed fusible link (165°F standard, 212°F optional)
- Meets UL 555 and NFPA requirements

Damper Mounting	Minimum Size	Maximum Single Section Size
Vertical	6" x 6"	36" x 36"
Horizontal	6" x 6"	24" x 24"

Listed sizes are width by height.
Contact factory for sizes exceeding published limits.

MODEL FDD-B-S

1-1/2 Hour, Type B Dynamic Fire Damper w/Integral Sleeve

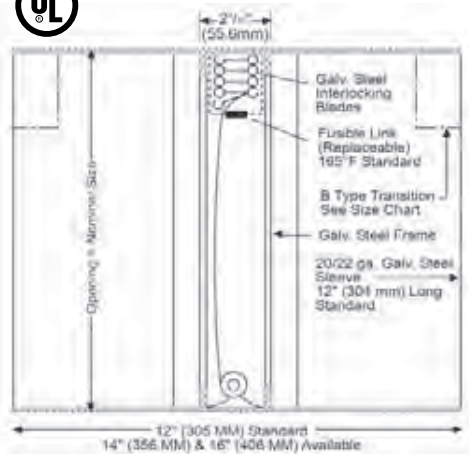

FEATURES

- Roll-formed galvanized steel frame and blades
- Available in vertical (V) or horizontal (H) models
- Stainless steel closure spring
- Provided 1/4" under duct size
- Provided with UL-listed fusible link (165°F standard, 212°F optional)
- Meets UL 555 and NFPA requirements

Damper Mounting	Minimum Size	Maximum Single Section Size
Vertical	6" x 4"	36" x 32"
Horizontal	6" x 4"	24" x 21"

Listed sizes are width by height.
Contact factory for sizes exceeding published limits.

See damper sizing chart for damper oversize allowance.



FEATURES

- Roll-formed galvanized steel frame and blades
- Available in vertical (V) or horizontal (H) models
- Stainless steel closure spring
- Provided 1/4" under duct size
- Provided with UL-listed fusible link (165°F standard, 212°F optional)
- Meets UL 555 and NFPA requirements
- Available with square to square, square to round or square to oval connections

Damper Mounting	Minimum Size	Maximum Single Section Size
Vertical	5" x 3"	35" x 31"
Horizontal	5" x 3"	23" x 20"

Listed sizes are width by height.
 Contact factory for sizes exceeding published limits.
 See damper sizing chart for damper oversize allowance.
 Minimum round connection size is 4" diameter.

MODEL FDD-C-S

1-1/2 Hour, Type C Dynamic Fire Damper w/Integral Sleeve and Transitions

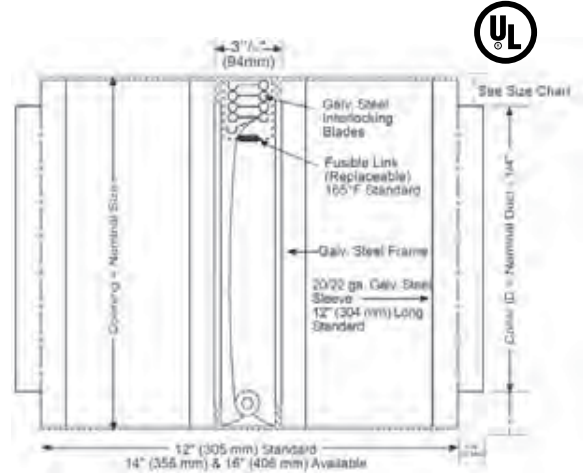



MODEL CD-RD-A

True Round Ceiling Damper

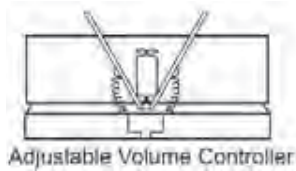
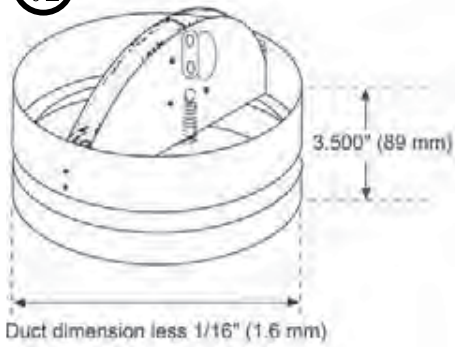

FEATURES

- Galvanized steel frame and blades
- Corrosion resistant steel closure spring
- Provided 1/16" under duct size
- Provided with UL-listed fusible link (212°F standard, 165°F optional)
- Ceramic blanket blade insulation on larger sizes
- Available with optional adjustable volume control
- Meets UL 555 and NFPA requirements

Minimum Size	Maximum Size
5" dia.	18" dia.

Listed sizes are width by height.
Contact factory for sizes exceeding published limits.

MODEL CD-S/R-A

Square/Rectangular Ceiling Damper

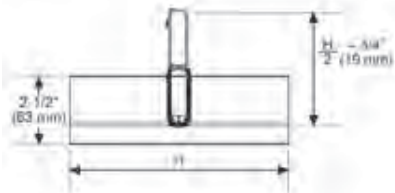
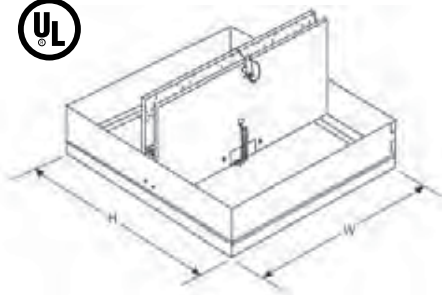

FEATURES

- Galvanized steel frame and blades
- Corrosion resistant steel closure spring
- Provided 1/8" under duct size
- Provided with UL-listed fusible link (212°F standard, 165°F optional)
- Ceramic blanket blade insulation on larger sizes
- Available with optional adjustable volume control
- Meets UL 555 and NFPA requirements

Minimum Size	Maximum Size
4" x 6"	22" x 22"

Listed sizes are width by height.
Contact factory for sizes exceeding published limits.



FEATURES

- Galvanized steel frame and blades
- Corrosion resistant steel closure spring
- Provided 1/16" under duct size
- Provided with UL-listed fusible link (212°F standard, 165°F optional)
- Ceramic blanket blade insulation on larger sizes
- Available with optional adjustable volume control
- Meets UL 555 and NFPA requirements

Minimum Size	Maximum Size
4" x 6"	16" x 12"

Listed sizes are width by height.
Contact factory for sizes exceeding published limits.

These dampers have been approved for, but not limited to, wood joist systems incorporating gypsum wall board ceilings. Designs specifically tested pertain to UL L501, L502, L503, L506, L507, L508, L512, L513, L514, L515, L516, L517, L519, L522, L523, L524, L533, L545 designs and the ULC M500 design, but are not limited to them. New UL ceiling designs are constantly being added. Refer to the UL Fire Resistance Directory for currently approved listings.

MODEL CD-S/R-HC

Ceiling Damper for Gypsum Ceilings



Model 101M & 102M
1 & 2 Way Stamped Face Grille

CFM	Outlet Size	8x4	10x6	12x6	14x6	12x8	14x8
50	Neck Velocity	225					
	Ps	.006					
	Throw	6					
100	Neck Velocity	450	240	200			
	Ps	.023	.006	.004			
	Throw	9	7	7			
150	Neck Velocity	675	360	300	257	225	
	Ps	.051	.015	.10	.007	.006	
	Throw	12	10	9	9	8	
200	Neck Velocity	900	480	400	343	300	257
	Ps	.091	.026	.018	.013	.010	.007
	Throw	15	12	11	11	10	10
250	Neck Velocity	600	500	429	375	321	
	Ps	.040	.128	.021	.016	.012	
	Throw	14	13	12	12	11	
300	Neck Velocity	720	600	514	450	386	
	Ps	.058	.040	.030	.023	.017	
	Throw	16	15	14	13	13	
350	Neck Velocity	840	700	600	525	450	
	Ps	.079	.055	.040	.031	.023	
	Throw	17	16	16	15	14	
400	Neck Velocity	800	686	600	514		
	Ps	.091	.067	.051	.038		
	Throw	20	19	18	17		
450	Neck Velocity	900	771	675	579		
	Ps	.112	.082	.063	.046		
	Throw	21	20	19	18		
500	Neck Velocity	857	750	643			
	Ps	.100	.076	.056			
	Throw	21	20	19			
550	Neck Velocity	825	707				
	Ps	.091	.067				
	Throw	22	20				
600	Neck Velocity	900	771				
	Ps	.107	.078				
	Throw	23	22				
650	Neck Velocity	836					
	Ps	.091					
	Throw	23					
700	Neck Velocity	900					
	Ps	.096					
	Throw	25					

Model 103M
3 Way Stamped Face Grille

CFM	Outlet Size	8x4	12x4	10x6	12x6	14x6	12x8
50	Neck Velocity	225					
	Ps	.006					
	Throw	6 4					
100	Neck Velocity	450	300	240	200		
	Ps	.023	.009	.006	.004		
	Throw	8 6	9 7	7 6	7 5		
150	Neck Velocity	675	450	360	300	257	225
	Ps	.051	.020	.015	.010	.007	.006
	Throw	12 9	11 8	10 7	9 7	9 7	8 6
200	Neck Velocity	900	600	480	400	343	300
	Ps	.091	.035	.026	.018	.013	.010
	Throw	15 11	13 10	12 9	11 8	11 8	10 8
250	Neck Velocity	750	600	500	429	375	
	Ps	.055	.040	.028	.021	.016	
	Throw	15 11	14 10	13 10	12 9	12 9	
300	Neck Velocity	900	720	600	514	450	
	Ps	.079	.058	.040	.030	.023	
	Throw	17 13	16 12	15 11	14 11	13 10	
350	Neck Velocity	840	700	600	525		
	Ps	.079	.055	.040	.031		
	Throw	17 13	16 12	16 12	15 11		
400	Neck Velocity	800	686	600			
	Ps	.091	.067	.051			
	Throw	20 15	19 14	18 13			
450	Neck Velocity	900	771	675			
	Ps	.112	.082	.063			
	Throw	21 16	20 15	19 14			
500	Neck Velocity	857	760				
	Ps	.100	.076				
	Throw	21 16	20 15				
550	Neck Velocity	825					
	Ps	.091					
	Throw	22 16					
600	Neck Velocity	900					
	Ps	.107					
	Throw	23 17					

Performance Notes

1. Neck Velocity – The neck velocity is in feet per minute.
2. Ps – Static pressure readings are in inches water gauge.
3. Throw – Throws indicated are based on total number of feet of projected air when a terminal velocity of 50 feet per minute is reached. Values reflect side louver throw and center louver throw respectively. Throw should extend at least 75% of the distance from the face of the grille to the wall opposite the outlet. Throws are based on a 9 foot ceiling height.

Model 104M
4 Way Stamped Face Grille

CFM	Outlet Size	6x6	8x8	10x10	12x12
50	Neck Velocity	200			
	Ps	.004			
	Throw	5 4			
100	Neck Velocity	400	225		
	Ps	.018	.066		
	Throw	9 7	7 5		
150	Neck Velocity	600	338	216	
	Ps	.040	.014	.004	
	Throw	9 7	9 7	8 6	
200	Neck Velocity	800	450	238	225
	Ps	.072	.025	.007	.004
	Throw	14 11	11 8	10 7	9 7
250	Neck Velocity	563	360	250	
	Ps	.038	.012	.006	
	Throw	13 10	11 9	10 8	
300	Neck Velocity	675	432	300	
	Ps	.055	.017	.008	
	Throw	15 11	13 10	11 9	
350	Neck Velocity	787	504	350	
	Ps	.075	.023	.011	
	Throw	16 12	14 11	13 10	
400	Neck Velocity	900	576	400	
	Ps	.125	.038	.018	
	Throw	20 15	17 13	15 11	
450	Neck Velocity	648	450		
	Ps	.047	.023		
	Throw	18 14	16 12		
500	Neck Velocity	720	500		
	Ps	.057	.027		
	Throw	20 15	17 13		
550	Neck Velocity	792	550		
	Ps	.067	.032		
	Throw	21 16	18 14		
600	Neck Velocity	864	600		
	Ps	.079	.038		
	Throw	22 16	19 15		
700	Neck Velocity	700			
	Ps	.044			
	Throw	20 15			

Model 1300
Stamped Face Baseboard Return Grille

CFM	Outlet Size	12x6	18x6	24x6	20x8	24x8	30x8	24x12	30x12	
100	Face Velocity	200								
150	Face Velocity	300	200	150						
200	Face Velocity	400	267	200	180	150				
250	Face Velocity	500	333	250	225	188	150			
300	Face Velocity	600	400	300	270	225	180			
350	Face Velocity	467	350	315	263	210	150			
400	Face Velocity	533	400	360	300	240	175			
450	Face Velocity	600	450	405	338	270	200	160		
500	Face Velocity	500	450	375	300	225	180			
550	Face Velocity	550	495	413	330	250	200			
600	Face Velocity	600	540	450	360	275	220			
650	Face Velocity	585					488	390	300	240
700	Face Velocity	525					420	325	260	

Performance Notes

1. Face Velocity – The average face velocity is in feet per minute as measured 1" from face.
2. Stated performance are the most popular sizes; complete performance for all sizes is available upon request.

Model 1320
Stamped Face Toe-Space Grille

CFM	Outlet Size	2x10	2x12	2x14
25	Neck Velocity	120	100	
	Ps	.003	.002	
	Spread / Throw	2 2	1 1	
50	Neck Velocity	204	200	171
	Ps	.012	.008	.006
	Spread / Throw	5 4	5 4	4 3
75	Neck Velocity	360	300	257
	Ps	.026	.008	.013
	Spread / Throw	7 5	5 5	6 5
100	Neck Velocity	480	400	343
	Ps	.047	.032	.024
	Spread / Throw	8 7	8 6	7 6
125	Neck Velocity	600	500	429
	Ps	.073	.051	.037
	Spread / Throw	10 6	9 7	8 7
150	Neck Velocity	720	600	514
	Ps	.105	.073	.054
	Spread / Throw	11 9	10 8	10 8
200	Neck Velocity	800	686	
	Ps	.130	.095	
	Spread / Throw	12 10	12 9	

Performance Notes

1. Ps – Static pressure readings are in inches water gauge.
2. Throw – Throws indicated are based on total number of feet projected air when a terminal velocity of 50 feet per minute is reached.
3. Spread – Horizontal spread is measured in feet.
4. Neck Velocity – The neck velocity is in feet per minute.

Model 201M

1 Way Curved Blade Stamped Face Grille

CFM	Outlet Size	8x4	10x4	12x4	8x6	10x6	12x6	14x6	12x8
50	Neck Velocity	225	180	150	150				
	Ps	.002	.001	.001	.001				
	Throw	13	12	11	11				
100	Neck Velocity	450	360	300	300	240	200	171	150
	Ps	.007	.003	.002	.003	.002	.001	.001	.001
	Throw	21	20	19	19	17	16	15	14
150	Neck Velocity	450	360	300	300	240	200	171	150
	Ps	.008	.005	.006	.003	.002	.002	.001	
	Throw	26	24	24	23	21	20	19	
200	Neck Velocity		600	600	480	400	343	300	
	Ps		.010	.010	.006	.003	.003	.002	
	Throw		30	30	28	26	25	23	
250	Neck Velocity				600	500	429	375	
	Ps				.010	.005	.005	.003	
	Throw				32	30	29	27	
300	Neck Velocity				600	514	450		
	Ps				.008	.007	.004		
	Throw				34	32	31		
350	Neck Velocity				600	525			
	Ps				.010	.006			
	Throw				36	34			
400	Neck Velocity				600				
	Ps				.010				
	Throw				41				

Model 203M

3 Way Curved Blade Stamped Face Grille

CFM	Outlet Size	10x6	8x8	12x6	10x8	14x6	12x8	14x8
100	Neck Velocity	240	225	200	180	171	150	
	Ps	.002	.001	.001	.001	.001	.001	
	Throw	12	10	12	10	11	9	10
150	Neck Velocity	360	338	300	270	257	225	193
	Ps	.004	.003	.002	.002	.002	.001	.001
	Throw	16	14	15	13	14	13	13
200	Neck Velocity	480	450	400	360	343	300	257
	Ps	.007	.005	.004	.004	.003	.002	.001
	Throw	19	17	19	16	17	15	15
250	Neck Velocity	563	500	450	429	375	321	
	Ps	.008	.007	.006	.005	.003	.002	
	Throw	22	19	21	18	20	17	18
300	Neck Velocity		600	540	450	386		
	Ps		.010	.008	.007	.004	.003	
	Throw		24	21	23	20	21	19
350	Neck Velocity			600	525	450		
	Ps			.010	.006	.004		
	Throw			25	22	24	21	23
400	Neck Velocity			600	514			
	Ps			.010	.007			
	Throw			28	25	27	24	
450	Neck Velocity					579		
	Ps					.015		
	Throw					35	30	

Model 202M

2 Way Curved Blade Stamped Face Grille

CFM	Outlet Size	10x6	12x6	12x8
100	Neck Velocity	240	200	150
	Ps	.002	.001	.001
	Throw	14	13	12
150	Neck Velocity	360	300	225
	Ps	.004	.002	.001
	Throw	19	18	16
200	Neck Velocity	480	400	300
	Ps	.007	.004	.002
	Throw	23	22	20
250	Neck Velocity	600	500	375
	Ps	.012	.007	.004
	Throw	27	25	23
300	Neck Velocity	600	450	
	Ps	.010	.005	
	Throw	28	26	
350	Neck Velocity	600		
	Ps	.007		
	Throw	29		
400	Neck Velocity	600		
	Ps	.012		
	Throw	34		

Model 204M

4 Way Curved Blade Stamped Face Grille

CFM	Outlet Size	6x6	8x8
50	Neck Velocity	200	
	Ps	.001	
	Throw	8	7
100	Neck Velocity	400	225
	Ps	.005	.001
	Throw	14	12
150	Neck Velocity	600	338
	Ps	.012	.003
	Throw	19	16
200	Neck Velocity	450	
	Ps	.005	
	Throw	19	16
250	Neck Velocity	563	
	Ps	.008	
	Throw	11	19

Model 1340

Stamped Face Baseboard Diffuser

CFM	18" Width	
50	Face Velocity	246
	Ps	.005
	Ps	.004
	Spread / Throw	4 / 5
	Face Velocity	389
75	Ps	.009
	Ps	.006
	Spread / Throw	5 / 6
	Face Velocity	490
	Ps	.026
100	Ps	.018
	Spread / Throw	10 / 10
	Face Velocity	612
	Ps	.036
	Ps	.030
125	Spread / Throw	11 / 11
	Face Velocity	735
	Ps	.050
	Ps	.034
	Spread / Throw	12 / 13
150	Face Velocity	858
	Ps	.064
	Ps	.043
	Spread / Throw	14 / 15
	Face Velocity	980
175	Ps	.098
	Ps	.066
	Spread / Throw	16 / 17
	Face Velocity	
	Ps	

Performance Notes

1. Neck Velocity – The neck velocity is in feet per minute.
2. Face Velocity – The discharge velocity is in feet per minute.
3. Ps – Static pressure readings are in inches water gauge.
4. Throw – Throws indicated are based on total number of feet of projected air when a terminal velocity of 50 feet per minute is reached. Values reflect side louver throw and center louver throw respectively. Throw should extend at least 75% of the distance from the face of the grille to the wall opposite the outlet. Throws are based on a 9 foot ceiling height.
5. Spread - Horizontal spread is measured in feet per minute.

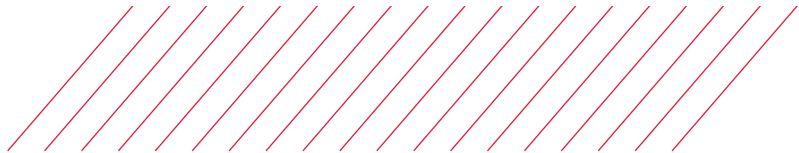
Model 1400, 1410F, 1420F, 1410FTB, 1410FTBI
Stamped Face Return / Return Air Filter Grille

Size	Area		Inlet Velocity		200	300	400	500	600	700	800	900	1000
	Ak	PS	.004	.008	.014	.022	.032	.044	.057	.072	.089		
10x10	.69	CFM	139	208	278	347	417	486	556	625	694		
	.69	NC	16	20	26	31	37	44	50	57	64		
12x8	.67	CFM	133	200	267	333	400	467	533	600	667		
	.65	NC	15	20	25	31	37	43	50	57	64		
12x12	1.00	CFM	200	300	400	500	600	700	800	900	1000		
	.98	NC	15	20	25	31	37	43	50	57	64		
14x6	.58	CFM	117	175	233	292	350	408	467	525	583		
	.57	NC	<15	20	25	31	37	43	49	56	63		
14x8	.78	CFM	156	233	311	389	467	544	622	700	778		
	.76	NC	16	21	26	32	38	44	51	58	65		
14x14	1.36	CFM	272	408	544	681	817	953	1089	1225	1361		
	1.33	NC	19	23	29	34	40	47	53	60	>65		
16x16	1.78	CFM	356	533	711	889	1067	1244	1422	1600	1778		
	1.74	NC	20	24	30	35	41	48	54	61	>65		
18x12	1.50	CFM	300	450	600	750	900	1050	1200	1350	1500		
	1.47	NC	19	24	29	35	41	47	54	60	>65		
18x18	2.25	CFM	450	675	900	1125	1350	1575	1800	2025	2250		
	2.21	NC	21	25	31	36	42	49	55	62	>65		
20x10	1.36	CFM	278	417	556	694	833	972	1111	1250	1389		
	1.36	NC	19	23	29	34	40	47	53	6	>65		
20x12	1.67	CFM	333	500	667	833	1000	1167	1333	1500	1667		
	1.63	NC	19	24	29	35	41	47	54	61	>65		
20x14	1.94	CFM	389	583	778	972	1167	1361	1556	1750	1944		
	1.91	NC	20	25	30	36	42	48	55	62	>65		
20x16	2.22	CFM	444	667	889	1111	1333	1556	1778	2000	2222		
	2.18	NC	21	25	31	36	42	49	55	62	>65		
20x18	2.5	CFM	500	750	1000	1250	1500	1750	2000	2250	2500		
	2.45	NC	21	26	31	37	43	49	56	63	>65		
20x20	2.78	CFM	556	833	1111	1389	1667	1944	2222	2500	2778		
	2.72	NC	22	26	32	37	43	50	56	63	>65		
22x22	3.36	CFM	672	1008	1344	1681	2017	2353	2689	3025	3361		
	3.29	NC	22	27	32	38	44	50	57	64	>65		
24x8	1.33	CFM	267	400	533	667	800	933	1067	1200	1333		
	1.31	NC	18	23	28	34	40	46	53	60	>65		
24x10	1.67	CFM	333	500	667	833	1000	1167	1333	1500	1667		
	1.63	NC	19	24	29	35	41	47	54	61	>65		
24x12	2.00	CFM	400	600	800	1000	1200	1400	1600	1800	2000		
	1.96	NC	20	25	30	36	42	48	55	62	>65		
24x14	2.33	CFM	467	700	933	1167	1400	1633	1867	2100	2333		
	2.29	NC	21	26	31	37	43	49	55	62	>65		
24x16	2.67	CFM	533	800	1067	1333	1600	1867	2133	2400	2667		
	2.61	NC	21	26	31	37	43	49	56	63	>65		
24x18	3.00	CFM	600	900	1200	1500	1800	2100	2400	2700	3000		
	2.94	NC	22	27	32	38	44	50	57	63	>65		
24x20	3.33	CFM	667	1000	1333	1667	2000	2333	2667	3000	3333		
	3.27	NC	22	27	32	38	44	50	57	64	>65		
Throw			N/A	N/A	N/A	N/A	N/A	N/A	N/A	N/A	N/A	N/A	N/A

Size	Area		Inlet Velocity		200	300	400	500	600	700	800	900	1000
	Ak	PS	.005	.011	.020	.031	.045	.061	.080	.101	.125		
24x24	4.00	CFM	800	1200	1600	2000	2400	2800	3200	3600	4000		
	3.92	NC	23	28	33	39	45	51	58	65	>65		
25x12	2.08	CFM	417	625	833	1042	1250	1458	1667	1875	2083		
	2.04	NC	20	25	30	36	42	48	55	62	>65		
25x14	2.43	CFM	486	729	972	1215	1458	1701	1944	2188	2431		
	2.38	NC	21	26	31	37	43	49	56	62	>65		
25x16	2.78	CFM	556	833	1111	1389	1667	1944	2222	2500	2778		
	2.72	NC	22	26	32	37	43	50	56	63	>65		
25x18	3.13	CFM	625	938	1250	1563	1875	2188	2500	2813	3125		
	3.06	NC	22	27	32	38	44	50	57	64	>65		
25x20	3.47	CFM	694	1042	1389	1736	2083	2431	2778	3125	3472		
	3.40	NC	23	27	33	38	44	51	57	64	>65		
25x25	4.34	CFM	868	1302	1736	2170	2604	3038	3472	3906	4340		
	4.25	NC	24	28	34	39	45	52	58	>65	>65		
28x14	2.72	CFM	544	817	1089	1361	1633	1906	2178	2450	2722		
	2.67	NC	22	26	32	37	43	50	56	63	>65		
30x6	1.25	CFM	250	375	500	625	750	875	1000	1125	1250		
	1.23	NC	18	23	28	34	40	46	53	60	>65		
30x10	2.08	CFM	417	625	833	1042	1250	1458	1667	1875	2083		
	2.04	NC	20	25	30	36	42	48	55	62	>65		
30x12	2.5	CFM	500	750	1000	1250	1500	1750	2000	2250	2500		
	2.45	NC	21	26	31	37	43	49	56	63	>65		
30x14	2.92	CFM	583	875	1167	1458	1750	2042	2333	2625	2917		
	2.86	NC	22	27	32	38	44	50	56	63	>65		
30x16	3.33	CFM	667	1000	1333	1667	2000	2333	2667	3000	3333		
	3.27	NC	22	27	32	38	44	50	57	64	>65		
30x18	3.75	CFM	750	1125	1500	1875	2250	2625	3000	3375	3750		
	3.68	NC	23	28	33	39	45	51	58	64	>65		
30x20	4.17	CFM	833	1250	1667	2083	2500	2917	333	3750	4167		
	4.08	NC	23	28	33	39	45	51	58	65	>65		
30x24	5.00	CFM	1000	1500	2000	2500	3000	3500	4000	4500	5000		
	4.90	NC	24	29	34	40	46	52	59	>65	>65		
30x25	5.21	CFM	1042	1563	2083	2604	3125	3646	4167	4688	5208		
	5.10	NC	24	29	34	40	46	52	59	>65	>65		
30x30	6.25	CFM	1250	1875	2500	3125	3750	4375	5000	5625	6250		
	6.13	NC	25	30	35	41	47	53	60	>65	>65		
32x25	5.56	CFM	1111	1667	2222	2778	3333	3889	4444	5000	5556		
	5.44	NC	25	29	35	40	46	53	59	>65	>65		
36x12	3.00	CFM	600	900	1200	1500	1800	2100	2400	2700	3000		
	2.94	NC	22	27	32	38	44	50	57	63	>65		
36x18	4.50	CFM	900	1350	1800	2250	2700	3150	3600	4050	4500		
	4.41	NC	24	28	34	39	45	52	58	>65	>65		
36x20	5.00	CFM	1000	1500	2000	2500	3000	3500	4000	4500	5000		
	4.90	NC	24	29	34	40	46	52	59	>65	>65		
36x24	6.00	CFM	1200	1800	2400	3000	3600	4200	4800	5400	6000		
	5.88	NC	25	30	35	41	47	53	60	>65	>65		
Throw			N/A	N/A	N/A	N/A	N/A	N/A	N/A	N/A	N/A	N/A	N/A

Performance Notes:

- All units have been tested in accordance with ANSI / ASHRAE 70-2006. Data in table is derived from such testing.
- Ps – Static pressure required to obtain listed cfm, units of inches water gauge (in. wg.).
- NC – Calculated noise criteria using 10 dB per octave room attenuation (dimensionless).
- Throw – Non-isothermal throw, in feet, for a terminal velocity of 50 fpm.
- For reverse size grilles use the performance as per the example below:
Example: 1



Model 1500, 1510D, 1510DX, 1510X, 1520M
Steel Stamped Face Floor Grilles / Registers

CFM	Outlet Size	2x10	2x12	2x14	4x8	4x10	4x12	4x14	6x10	6x12	6x14	
25	Face Velocity	160										
	Ps	.007										
	Spread / Throw	3 2										
50	Face Velocity	320	267	229	225	180	150					
	Ps	.029	.020	.015	.015	.009	.006					
	Spread / Throw	6 4	5 4	5 4	5 4	4 3	4 3					
75	Face Velocity	480	400	343	338	270	225	193	180	150		
	Ps	.066	.046	.034	.034	.021	.014	.011	.009	.006		
	Spread / Throw	7 6	7 5	7 5	7 5	6 5	6 4	5 4	5 4	5 4		
100	Face Velocity	640	533	457	450	360	300	257	240	200	171	
	Ps	.117	.081	.060	.060	.037	.026	.019	.011	.011	.008	
	Spread / Throw	9 7	8 6	8 6	8 6	7 6	7 5	7 5	6 5	6 5	6 4	
125	Face Velocity	800	667	571	563	450	375	321	300	250	214	
	Ps	.183	.127	.093	.093	.058	.040	.030	.026	.018	.013	
	Spread / Throw	11 6	10 7	9 7	9 7	9 6	8 6	8 6	8 6	7 5	7 5	
150	Face Velocity	800										
	Ps	.183	.135	.135	.083	.058	.043	.037	.026	.019		
	Spread / Throw	11 6										
175	Face Velocity	800										
	Ps	.183	.183	.114	.079	.058	.050	.035	.026			
	Spread / Throw	12 9										
200	Face Velocity	900										
	Ps	.239	.188	.130	.096	.083	.058	.043				
	Spread / Throw	14 11										
225	Face Velocity	810										
	Ps	.232	.161	.118	.103	.072	.053					
	Spread / Throw	14 10										
250	Face Velocity	900										
	Ps	.272	.195	.143	.125	.067	.064					
	Spread / Throw	16 12										
275	Face Velocity	825										
	Ps	.232	.170	.148	.103	.076						
	Spread / Throw	15 11										
300	Face Velocity	900										
	Ps	.272	.200	.174	.121	.089						
	Spread / Throw	16 12										
325	Face Velocity	836										
	Ps	.232	.202	.140	.103							
	Spread / Throw	15 12										
350	Face Velocity	900										
	Ps	.267	.232	.161	.118							
	Spread / Throw	16 13										

Performance Notes:

1. Neck Velocity – The neck velocity is in feet per minute.
2. Face Velocity – The discharge velocity is in feet per minute.
3. Ps – Static pressure readings are in inches water gauge.
4. Throw – Throws indicated are based on total number of feet of projected air when a terminal velocity of 50 feet per minute is reached. Values reflect side louver throw and center louver throw respectively. Throw should extend at least 75% of the distance from the face of the grille to the wall opposite the outlet. Throws are based on a 9 foot ceiling height.
5. Spread – Horizontal spread is measured in feet per minute.

Model 2000F, 2000FD (0* Deflection)
Extruded Aluminum Bar Grille

Listed Width (in inches)	Outlet Velocity Static Pressure (Ps)	NC	500	700	900	1000	1100	1200	1300
			.016	.031	.051	.062	.076	.090	.105
2 0.086	Flow CFM / LFT		43	60	77	85	94	102	111
	Throw, Sill or Floor		5 8	8 12	10 14	11 16	13 18	13 19	14 20
	Throw Side Wall		7 10	10 15	13 18	14 20	15 22	17 24	17 25
4 0.176	Flow CFM / LFT		110	154	198	220	242	264	286
	Throw, Sill or Floor		8 11	13 18	14 20	16 23	18 26	19 27	20 29
	Throw Side Wall		10 14	15 22	17 25	20 29	22 32	24 34	25 26
6 0.265	Flow CFM / LFT		133	186	239	265	292	318	345
	Throw, Sill or Floor		8 12	13 18	15 22	17 25	18 26	20 28	21 30
	Throw Side Wall		10 15	15 22	19 27	22 31	23 33	24 35	27 38

Model 1530, 1530M
Steel Bar Floor Grille

Outlet Size	6x6	4x8	4x10	4x12	8x8	6x12	6x14	4x24	8x12		
Area	0.250	0.260	0.278	0.333	0.444	0.500	0.583	0.667	0.667		
CFM	Face Velocity										
50	200										
75	300	289	270	225							
100	400	385	360	300	225	200					
125	500	481	450	375	282	250	215				
150	600	577	540	450	338	300	258	225	225		
200	769		720	600	450	400	343	300	300		
250				750	563	500	429	375	375		
300					675	600	515	450	450		
350						788	700	600	525	525	
400							686	600	600	600	
450								772	675	675	675

Outlet Size	10x10	8x14	10x14	6x24	12x12	6x30	8x24	12x18	12x30	
Area	0.694	0.778	0.972	1.000	1.000	1.250	1.333	1.500	2.500	
CFM	Face Velocity									
150	216									
200	288	257	206	200	200					
250	360	321	257	250	250	200				
300	432	386	309	300	300	240	225	200		
400	576	514	411	400	400	320	300	267		
500	720	643	514	500	500	400	375	333	200	
600	771		617	600	600	480	450	400	240	
700				720	700	560	525	467	280	
800					640	600	533	320		
900						720	675	600	360	
1000							667	400		

Outlet Size	18x18	20x20	18x24	18x30	24x24	18x36	20x36	24x30	24x36
Area	2.250	2.778	3.000	3.750	4.000	4.500	5.000	5.000	6.000
CFM	Face Velocity								
500	222								
600	267	216	200						
700	311	252	233						
800	356	288	267	213	200				
900	400	324	300	240	225	200			
1000	444	360	333	267	250	222	200	200	
1500	667	540	500	400	375	333	300	300	250
2000	720		667	533	500	444	400	400	333
2500				667	625	556	500	500	417
3000					667	600	600	500	600
4000						667	600	600	600

Performance Notes:

1. All units have been tested in accordance with ANSI / ASHRAE 70-2006. Data in table is derived from such testing.
2. Ps – Static pressure readings are in inches water gauge.
3. NC – Calculated noise criteria using 10 dB per octave room attenuation (dimensionless).
4. Ak – Area factors per foot.

PERFORMANCE DATA

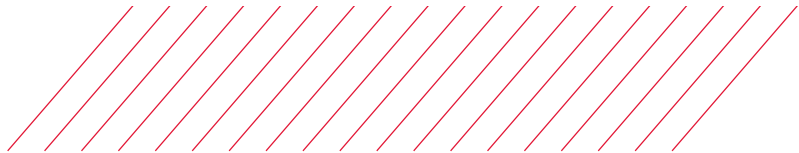

Model 4000SVM, (HV) 4002, (HV) 4002D, (HV) 4002M, (HV) 4004, (HV) 4004D, (HV) 4002S, (HV) 4004S, 4004P, 4004SP

Single and Double Deflection Sidewall Supplies

PERFORMANCE DATA

Size	Area		Inlet Velocity	Throw																			
	Ak	PS		.200	.300	.400	.500	.600	.700	.800	.900	1000											
6x6	.25	CFM	50	75	125	125	150	175	200	225	250	24x6	1.00	CFM	200	300	400	500	600	700	800	900	1000
	.20	NC	<15	<15	<15	<15	<15	<15	16	19	23		.78	NC	<15	<15	<15	<15	<15	16	19	22	26
8x8	.44	CFM	89	133	178	222	267	311	356	400	444	24x8	1.33	CFM	267	400	533	667	800	933	1067	1200	1333
	.35	NC	<15	<15	<15	<15	<15	16	19	22	25		1.04	NC	<15	<15	<15	<15	15	18	20	24	27
10x6	.42	CFM	83	125	167	208	250	292	333	375	417	24x10	1.67	CFM	333	500	667	833	1000	1167	1333	1500	1667
	.33	NC	<15	<15	<15	<15	<15	16	18	22	25		1.30	NC	<15	<15	<15	<15	16	19	21	25	28
10x8	.56	CFM	111	167	222	278	333	389	444	500	556	24x12	2.00	CFM	400	600	800	1000	1200	1400	1600	1800	2000
	.43	NC	<15	<15	<15	<15	<15	17	20	23	26		1.56	NC	<15	<15	<15	15	17	20	22	25	29
10x10	.69	CFM	139	208	278	347	417	486	556	625	694	24x16	2.67	CFM	533	800	1067	1333	1600	1867	2133	2400	2667
	.54	NC	<15	<15	<15	<15	16	18	21	24	27		2.08	NC	<15	<15	<15	16	18	21	24	27	30
12x6	.50	CFM	100	150	200	250	300	350	400	450	500	24x18	3.00	CFM	600	900	1200	1500	1800	2100	2400	2700	3000
	.39	NC	<15	<15	<15	<15	<15	16	19	22	26		2.34	NC	<15	<15	15	17	19	21	24	27	31
12x8	.67	CFM	133	200	267	333	400	467	533	600	667	24x24	2.00	CFM	800	1200	1600	2000	2400	2800	3200	3600	4000
	.52	NC	<15	<15	<15	<15	15	18	20	24	27		3.12	NC	<15	<15	16	18	20	23	25	28	32
12x12	1.00	CFM	200	300	400	500	600	700	800	900	1000	26x12	2.17	CFM	433	650	867	1083	1300	1517	1733	1950	2167
	.78	NC	<15	<15	<15	15	17	19	22	25	29		1.69	NC	<15	<15	<15	15	17	20	23	26	29
14x6	.58	CFM	117	175	233	292	350	408	467	525	583	26x26	4.69	CFM	939	1408	1878	2347	2817	3286	3756	4225	4694
	.46	NC	<15	<15	<15	<15	<15	<15	17	20	24		3.66	NC	<15	16	17	19	21	23	26	29	33
14x8	.78	CFM	156	233	311	389	467	544	622	700	778	28x12	2.33	CFM	467	700	933	1167	1400	1633	1867	2100	2333
	.61	NC	<15	<15	<15	<15	16	18	21	24	28		1.82	NC	<15	<15	<15	16	18	20	23	26	30
16x6	.67	CFM	133	200	267	333	400	467	533	600	667	28x28	5.44	CFM	1089	1633	2178	2722	3267	3811	4356	4900	5444
	.52	NC	<15	<15	<15	<15	<15	<15	17	21	24		4.25	NC	16	17	18	19	21	24	27	30	33
16x8	.89	CFM	178	267	356	444	533	622	711	800	889	30x6	1.25	CFM	250	375	500	625	750	875	1000	1125	1250
	.69	NC	<15	<15	<15	<15	17	19	22	25	28		.98	NC	<15	<15	<15	<15	15	17	20	23	27
18x6	.75	CFM	150	225	300	375	450	525	600	675	750	30x8	1.67	CFM	333	500	667	833	1000	1167	1333	1500	1667
	.59	NC	<15	<15	<15	<15	<15	15	18	21	25		1.30	NC	<15	<15	<15	<15	15	18	20	24	27
18x8	1.00	CFM	200	300	400	500	600	700	800	900	1000	30x10	2.08	CFM	417	625	833	1042	1250	1458	1667	1875	2083
	.78	NC	<15	<15	<15	15	17	19	22	25	29		1.63	NC	<15	<15	<15	15	17	20	22	26	29
20x6	.83	CFM	167	250	333	417	500	583	667	750	833	30x12	2.50	CFM	500	750	1000	1250	1500	1750	2000	2250	2500
	.65	NC	<15	<15	<15	<15	<15	16	18	22	25		1.95	NC	<15	<15	<15	16	18	20	23	26	30
20x8	1.11	CFM	222	333	444	556	667	778	889	1000	1111	36x8	2.00	CFM	400	600	800	1000	1200	1400	1600	1800	2000
	.87	NC	<15	<15	<15	<15	<15	17	20	23	26		1.56	NC	<15	<15	<15	15	17	20	22	25	29
20x10	1.39	CFM	200	300	400	500	600	700	800	900	1000	36x12	3.00	CFM	600	900	1200	1500	1800	2100	2400	2700	3000
	1.08	NC	<15	<15	<15	15	17	19	22	25	29		2.34	NC	<15	<15	15	17	19	21	24	27	31
20x12	1.67	CFM	267	400	533	667	800	933	1067	1200	1333	36x24	6.00	CFM	1200	1800	2400	3000	3600	4200	4800	5400	6000
	1.30	NC	<15	<15	<15	<15	15	18	20	24	27		4.68	NC	16	17	18	20	22	24	27	30	34
20x16	2.22	CFM	444	667	889	1111	1333	1556	1778	2000	2222	42x24	7.00	CFM	1400	2100	2800	3500	4200	4900	5600	6300	7000
	1.73	NC	<15	<15	<15	16	18	20	23	26	29		5.46	NC	17	18	19	21	23	25	28	31	34
20x18	2.50	CFM	500	750	1000	1250	1500	1750	2000	2250	2500	48x12	4.00	CFM	800	1200	1600	2000	2400	2800	3200	3600	4000
	1.95	NC	<15	<15	<15	16	18	20	23	26	30		3.12	NC	<15	15	16	18	20	23	25	28	32
20x20	2.78	CFM	556	833	1111	1389	1667	1944	2222	2500	2778	48x24	8.00	CFM	1600	2400	3200	4000	4800	5600	6400	7200	8000
	2.17	NC	<15	<15	<15	17	19	21	24	27	30		6.24	NC	17	18	19	21	23	26	28	31	35
22x10	1.53	CFM	306	458	611	764	917	1069	1222	1375	1528	48x36	12.00	CFM	2400	3600	4800	6000	7200	8400	9600	10800	12000
	1.19	NC	<15	<15	<15	<15	16	18	21	24	28		9.36	NC	19	20	21	23	25	27	30	33	37
22x22	3.36	CFM	672	1008	1344	1681	2017	2353	2689	3025	3361	48x48	16.00	CFM	3200	4800	6400	8000	9600	11200	12800	14400	16000
	2.62	NC	<15	<15	16	17	19	22	25	28	31		12.48	NC	20	21	22	24	26	29	31	34	38
Throw			12	18	24	30	36	42	47	53	59	Throw			12	18	24	30	36	42	47	53	59

Performance Notes:

1. All units have been tested in accordance with ANSI / ASHRAE 70-2006. Data in table is derived from such testing.
2. Ps – Static pressure required to obtain listed cfm, units of inches water gauge (in. wg.).
3. NC – Calculated noise criteria using 10 dB per octave room attenuation (dimensionless).
4. Throw – Non-isothermal throw, in feet, for a terminal velocity of 50 fpm.
5. Inlet Velocity = fpm (feet per minute).



Model 3100A, 3100SA, 3100, 3100S Commercial Round Ceiling Diffuser

Neck Size	Neck Area Sq FT	Inlet Velocity	CFM										
			200	300	400	500	600	700	800	900	1000	1100	
		PS	.006	.014	.025	.039	.056	.077	.100	.127	.156	.189	
6"	.165	CFM	39	59	79	98	118	137	157	177	196	216	
		NC	<15	<15	16	18	21	23	26	28	31	33	
8"	.307	CFM	70	105	140	175	209	244	279	314	349	384	
		NC	<15	16	18	21	23	26	28	31	33	36	
10"	.493	CFM	109	164	218	273	327	382	436	491	545	600	
		NC	16	18	20	23	25	28	30	33	35	38	
12"	.722	CFM	157	236	314	393	471	550	628	707	785	864	
		NC	17	20	22	24	27	29	32	34	37	39	
14"	.995	CFM	214	321	428	535	641	748	855	962	1069	1176	
		NC	18	21	23	26	28	31	33	36	38	40	
16"	1.312	CFM	279	419	559	698	838	977	1117	1257	1396	1536	
		NC	20	22	25	27	29	32	34	37	39	42	
18"	1.673	CFM	353	530	707	884	1060	1237	1414	1590	1767	1944	
		NC	21	23	26	28	30	33	35	38	40	43	
20"	1.673	CFM	436	654	873	1091	1309	1527	1745	1963	2182	2400	
		NC	22	24	26	29	31	34	36	39	41	44	
22"	1.673	CFM	528	792	1056	1320	1584	1848	2112	2376	2640	2904	
		NC	22	25	27	30	32	35	37	39	42	44	
24"	3.016	CFM	628	942	1257	1571	1885	2199	2513	2827	3142	3456	
		NC	23	26	28	30	33	35	38	40	43	45	
Throw			5	8	10	13	15	18	20	23	25	28	

Damper Table	
% Damper Open	Add to Listed NC
100 %	0
82 %	4
70 %	8
50 %	16

Performance Notes:

- Tabulated radial throw in feet is based on a 9' ceiling height, with supply air 20°F cooler than room temperature, MAX Horizontal Throw @ Vt = 50 fpm.
- Vertical down projection air pattern with cooling supply air temperature 20° below room temperature, and diffuser inner cones in up position: multiply the tabulated radial throw values by a factor of 0.80 to obtain vertical down projection distance at MIN and MAX (Vt) terminal velocities.
- Vertical down projection air pattern with heating supply air temperature 20° above room temperature, and diffuser inner cones in up position: multiply the tabulated radial throw values by a factor of 0.60 to obtain vertical down projection distance at MIN and MAX (Vt) terminal velocities.
- PS – are in inches of water.
- 3100 Round Diffusers are tested in accordance with ASHRAE 70-2006. Sound data are calculated in accordance with International Standard ISO 3741 comparison method. The NC values are based on a room absorption of 10 dB for sound power level (Lw) RE: 10E-12 watts. (<) symbol indicates NC less than number given. The NC data are for single diffusers: for results of throttling a volume damper, see Damper Table.
- All data are applicable for exposed duct mounting or ceiling installation.
- Inlet Velocity = fpm (feet per minute).

Model 5200 Square Ceiling Diffuser

CFM	Size	6x6	8x8	10x10	12x12	14x14	16x16	18x18	20x20	22x22	24x24
100	Neck Velocity	400	225	114	100						
	PS	.004	.001	.001	.001						
	Throw	20 17 14 12	17 14 12 10	14 12 10 9	12 10 8 7						
200	Neck Velocity	800	450	288	200	147					
	PS	.014	.004	.002	.001	.001					
	Throw	33 27 23 20	27 22 19 16	23 19 16 14	21 17 14 12	18 15 13 11					
300	Neck Velocity	900	576	400	294						
	PS	.008	.004	.002	.001						
	Throw	35 30 25 22	35 30 25 22	27 22 19 15	24 20 17 15						
400	Neck Velocity	900	576	400	294						
	PS	.019	.008	.004	.002						
	Throw	47 39 32 29	40 34 28 24	35 30 25 22	32 27 22 19						
600	Neck Velocity	864	600	441	216						
	PS	.017	.008	.003	.001						
	Throw		52 43 36 32	43 36 30 26	41 34 28 25	30 25 21 19					
800	Neck Velocity	800	588	450	356	288	238	200			
	PS	.018	.008	.005	.003	.002	.001	.001			
	Throw		57 48 40 35	51 43 36 31	47 39 32 29	43 37 30 27	40 34 28 24	35 29 24 21	33 27 23 20		
1000	Neck Velocity	735	563	444	360	298	250				
	PS	.014	.009	.006	.003	.002	.001				
	Throw		63 52 43 38	57 48 40 35	53 45 37 33	49 41 34 30	40 34 28 25	38 32 26 23			

Performance Notes:

- All data are tested in accordance with ANSI / ASHRAE 70-2006.
- PS – Static Pressure.
- Throw – Throws indicated are based on total number of feet of projected air when a terminal velocity of 50 fpm is reached. Numbers reported in chart are, from left to right, for 1, 2, 3 and 4-way throw patterns.
- Inlet Velocity = fpm (feet per minute).

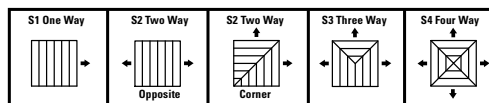

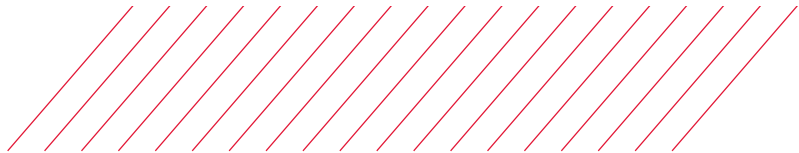

Model L, LD, LM, LMH, LT, LTD, LTM, LTMH, LTC, LTC3, LTCM, LS3, LS3D, LS3M, LTC3, LTC3D, LTC3M, LS4, LS4D, LS4M

Curve Blade (1 Way, 2 Way Opposite, 2 Way Corner, 3 Way, 3 Way Corner, 4 Way FLOW)

Size Area Ak	Inlet Velocity Ps	100	200	300	400	500	600	700	800	900	1000
		.003	.011	.026	.045	.075	.108	.145	.185	.236	.290
6x4	CFM	17	34	51	68	85	102	119	136	153	170
	.17 Throw	10-9-7-6	11-9-8-7	12-9-8-8	16-13-11-10	18-14-13-11	19-15-13-12	23-18-16-15	26-20-18-17	34-27-24-22	37-29-26-24
	.11 NC	<15	<15	<15	15	20	24	28	32	35	24
6x6	CFM	25	50	75	100	125	150	175	200	225	250
	.25 Throw	10-8-7-6	12-9-8-7	14-11-10-9	18-14-13-11	22-17-16-14	24-19-17-15	26-20-18-17	34-27-24-20	38-30-27-23	42-33-30-25
	.16 NC	<15	<15	<15	16	21	26	32	33	37	41
8x4	CFM	22	44	66	88	110	132	154	176	198	220
	.22 Throw	11-9-8-7	12-9-8-7	13-10-9-8	17-13-12-10	21-17-15-13	22-17-16-13	25-20-18-15	32-25-23-19	36-28-25-22	40-31-28-24
	.14 NC	<15	<15	<15	15	21	26	29	33	35	39
8x6	CFM	33	66	99	132	165	198	231	264	297	330
	.33 Throw	6-5-4-4	8-6-6-5	11-9-8-7	15-12-11-9	20-16-14-12	24-19-17-14	32-25-23-19	37-29-26-22	41-32-29-25	45-35-32-27
	.21 NC	<15	<15	15	17	23	28	32	35	38	41
8x8	CFM	44	88	132	176	220	264	308	352	396	440
	.44 Throw	7-6-5-4	9-7-6-5	12-9-8-7	17-13-12-10	21-21-19-18	26-20-18-16	35-28-25-21	40-31-28-24	44-35-31-26	49-39-35-29
	.28 NC	<15	<15	15	18	24	29	33	37	38	41
10x6	CFM	42	84	126	168	210	252	294	336	378	420
	.42 Throw	7-6-5-4	9-7-6-5	12-9-8-7	17-13-12-10	21-21-19-18	26-20-18-16	35-28-25-21	40-31-28-24	44-35-31-26	49-39-35-29
	.27 NC	<15	<15	15	18	24	29	33	37	38	41
10x8	CFM	56	112	168	224	280	336	392	448	504	560
	.56 Throw	9-7-6-5	11-9-8-7	17-13-12-10	22-17-16-13	23-18-16-14	32-25-23-19	37-29-26-22	42-33-30-25	47-37-33-28	53-42-37-32
	.36 NC	<15	<15	16	19	26	30	34	38	41	44
10x10	CFM	69	138	207	276	345	414	483	552	621	690
	.69 Throw	6-5-4-4	12-9-8-7	18-14-13-11	20-16-14-12	30-24-21-18	35-28-25-21	41-34-31-24	46-38-34-28	51-40-36-31	57-45-40-34
	.44 NC	<15	<15	15	20	26	31	36	39	42	45
12x6	CFM	50	100	150	200	250	300	350	400	450	500
	.50 Throw	8-6-6-5	9-7-6-5	12-9-8-7	18-14-13-11	22-17-16-13	31-24-22-19	36-28-25-22	41-32-2-25	46-36-33-28	51-40-36-31
	.32 NC	<15	<15	15	18	22	31	36	41	46	51
12x8	CFM	67	134	201	268	335	402	469	536	603	670
	.67 Throw	6-5-4-4	12-9-8-7	18-14-13-11	20-16-14-12	30-24-21-18	35-28-25-21	41-34-31-24	46-38-34-28	51-40-36-31	57-45-40-34
	.43 NC	<15	<15	15	20	26	31	36	39	42	45
12x12	CFM	100	200	300	400	500	600	700	800	900	1000
	1.00 Throw	7-6-5-4	14-11-10-8	20-16-14-12	22-17-16-13	32-25-23-19	39-31-28-23	45-35-32-27	50-39-35-30	56-44-40-34	63-50-45-38
	.64 NC	<15	<15	15	22	28	33	37	40	43	46
14x6	CFM	58	116	174	232	290	348	406	464	522	580
	.58 Throw	9-7-6-5	11-9-8-7	17-13-12-10	22-17-16-13	23-18-16-14	32-25-23-19	37-29-26-22	42-33-30-25	47-37-33-28	53-42-37-32
	.37 NC	<15	<15	16	19	26	30	34	38	41	44
14x10	CFM	97	194	291	388	485	582	679	776	873	970
	.97 Throw	7-6-5-4	13-10-9-8	20-16-14-12	22-17-16-13	32-25-23-19	38-30-27-23	44-35-31-26	49-39-35-29	55-43-39-33	62-49-44-37
	.62 NC	<15	<15	15	22	28	33	37	40	43	46
14x14	CFM	136	272	408	544	680	816	952	1088	1224	1360
	1.36 Throw	8-6-6-5	11-9-8-7	18-14-13-11	25-20-18-15	35-28-25-21	42-33-30-25	48-38-34-29	55-43-39-33	62-49-44-37	69-54-49-41
	.87 NC	<15	<15	16	24	29	34	40	43	46	49
16x6	CFM	67	134	201	268	335	402	469	536	603	670
	.67 Throw	6-5-4-4	12-9-8-7	18-14-13-11	20-16-14-12	30-24-21-18	35-28-25-21	41-34-31-24	46-38-34-28	51-40-36-31	57-45-40-34
	.43 NC	<15	<15	15	20	26	31	36	39	42	45
16x8	CFM	89	178	267	356	445	534	623	712	801	890
	.89 Throw	7-6-5-4	13-10-9-8	20-16-14-12	22-17-16-13	32-25-23-19	38-30-27-23	44-35-31-26	49-39-35-29	55-43-39-33	62-49-44-37
	.57 NC	<15	<15	15	22	28	33	37	40	43	46
20x10	CFM	139	278	417	556	695	834	973	1112	1251	1390
	1.39 Throw	8-6-6-5	11-9-8-7	18-14-13-11	25-20-18-15	35-28-25-21	42-33-30-25	48-38-34-29	55-43-39-33	62-49-44-37	69-54-49-41
	.89 NC	<15	<15	16	24	29	34	40	43	46	49
22x10	CFM	153	306	459	612	765	918	1071	1224	1377	1530
	1.53 Throw	8-6-6-5	11-9-8-7	19-15-13-11	25-20-18-15	36-28-25-22	43-34-30-26	50-39-35-30	56-44-40-34	63-50-45-38	70-55-50-42
	.98 NC	<15	<15	17	24	30	35	39	42	45	48

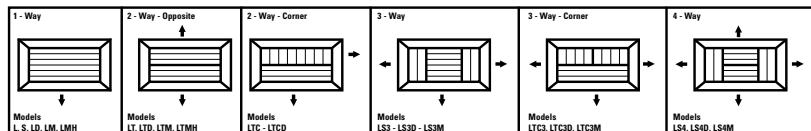

Performance Notes:

- All units have been tested in accordance with ANSI / ASHRAE 70-2006. Data in table is derived from such testing.
- Ps – Static pressure required to obtain listed cfm, units of inches water gauge (in. wg.).
- NC – Calculated noise criteria using 10 dB per octave room attenuation (dimensionless).
- Throw – Non-isothermal throw, in feet, for a terminal velocity of 50 fpm. Example: 25-20-18-15 (1 Way - 2 Way - 3 Way - 4 Way).
- Inlet Velocity = fpm (feet per minute).

Model V, VD, VM, VH, VHD Aluminum Roll Formed Single Deflection Aluminum Roll Formed Double Deflection

CFM	Outlet Size	8x4	10x6	12x6	14x6	12x8	14x8
50	Neck Velocity	225					
	Ps	.006					
	Throw	11 18					
100	Neck Velocity	450	240	200			
	Ps	.025	.007	.005			
	Throw	18 13	14 11	13 10			
150	Neck Velocity	675	360	300	257	225	
	Ps	.056	.016	.011	.008	.006	
	Throw	23 18	19 14	18 13	17 13	16 12	
200	Neck Velocity	900	480	400	343	300	257
	Ps	.100	.028	.020	.015	.011	.008
	Throw	28 21	23 17	22 16	20 15	20 15	19 14
250	Neck Velocity		600	500	429	375	321
	Ps		.045	.031	.023	.017	.013
	Throw		27 20	25 19	24 18	24 18	22 16
300	Neck Velocity		720	600	514	450	386
	Ps		.064	.045	.033	.025	.018
	Throw		30 23	28 21	27 20	26 19	24 18
350	Neck Velocity		840	700	600	525	450
	Ps		.087	.061	.045	.034	.025
	Throw		34 25	32 24	30 22	29 21	27 20
400	Neck Velocity			800	686	600	514
	Ps			.100	.074	.034	.041
	Throw			38 28	36 27	34 25	32 34
450	Neck Velocity			900	771	675	579
	Ps			.124	.091	.070	.051
	Throw			40 30	38 29	37 27	35 26
500	Neck Velocity				857	750	643
	Ps				.110	.084	.062
	Throw				41 31	39 29	37 28
550	Neck Velocity					825	707
	Ps					.100	.074
	Throw					41 31	39 29
600	Neck Velocity					900	771
	Ps					.118	.086
	Throw					44 33	42 33
650	Neck Velocity						836
	Ps						.066
	Throw						44 33
700	Neck Velocity						900
	Ps						.100
	Throw						44 33

Model 900, 900S Residential Round Ceiling Diffuser

CFM	Outlet Size	6"	8"	10"	12"	14"	
50	Neck Velocity	265					
	Ps	.008					
	Throw	3 5					
75	Neck Velocity	398	222				
	Ps	.017	.006				
	Throw	3 6	4 6				
100	Neck Velocity	531	296				
	Ps	.034	.011				
	Throw	4 6	4 6				
150	Neck Velocity	796	443	265			
	Ps	.075	.023	.009			
	Throw	5 7	5 7	5 8			
200	Neck Velocity	1062	591	353	260		
	Ps	.130	.040	.017	.009		
	Throw	6 8	5 8	5 9	6 9		
250	Neck Velocity	739	442	325	238		
	Ps	.060	.025	.013	.008		
	Throw	5 8	5 10	7 11	6 9		
300	Neck Velocity	887	530	390	286		
	Ps	.085	.035	.018	.010		
	Throw	5 9	6 12	7 12	7 11		
400	Neck Velocity	1183	706	520	381		
	Ps	.145	.060	.031	.018		
	Throw	7 11	7 13	8 13	8 13		
500	Neck Velocity		883	650	467		
	Ps		.090	.046	.027		
	Throw		7 14	9 14	9 14		
600	Neck Velocity		1060	780	571		
	Ps		.130	.064	.037		
	Throw		8 15	11 15	11 15		
700	Neck Velocity			910	667		
	Ps			.086	.049		
	Throw			12 17	12 17		
800	Neck Velocity				1040	762	
	Ps				.110	.062	
	Throw				13 19	13 19	
900	Neck Velocity					1170	857
	Ps					.140	.078
	Throw					15 21	15 21
1000	Neck Velocity						952
	Ps						.094
	Throw						18 23

Throws First Value 100 fpm - Second Value 50 fpm

Performance Notes:

1. Neck Velocity – The neck velocity is in feet per minute.
2. Ps – Static pressure readings are in inches water gauge.
3. Throw – Throws indicated are based on total number of feet of projected air when a terminal velocity of 50 feet per minute is reached. Values reflect side louver throw and center louver throw respectively. Throw should extend at least 75% of the distance from the face of the grille to the wall opposite the outlet. Throws are based on a 9 foot ceiling height. The first values of the throw at 0° deflection; second value represents throw at 22° deflection.



Model 9000-1, 9000-6 Louvered Directional Supply

Size Area Ak	Inlet Velocity Ps	200	300	400	500	600	700
6x6	CFM	50	75	100	125	150	175
	Throw	6-4-4-3	8-6-6-4	10-7-7-5	12-8-8-6	14-10-10-7	16-11-11-8
	NC	<20	<20	<20	20	26	31
8x8	CFM	90	130	175	220	265	310
	Throw	8-6-6-4	10-7-7-5	14-10-10-7	16-11-11-8	18-13-13-9	20-14-14-10
	NC	<20	<20	<20	23	28	33
10x10	CFM	140	205	275	345	415	485
	Throw	10-7-7-5	14-10-10-7	18-13-13-9	20-14-14-10	24-17-17-12	26-18-18-13
	NC	<20	<20	<20	23	26	31
12x12	CFM	200	300	400	500	600	700
	Throw	12-8-8-6	16-11-11-8	20-14-14-10	24-17-17-12	28-20-20-14	30-21-21-15
	NC	<20	<20	<20	25	31	36
14x14	CFM	270	405	545	680	815	950
	Throw	14-10-10-7	20-14-14-10	24-17-17-12	28-20-20-14	34-24-24-17	36-25-25-18
	NC	<20	<20	21	27	33	38
16x16	CFM	355	530	710	885	1070	1245
	Throw	16-11-11-8	22-16-16-11	28-20-20-14	32-22-22-16	38-27-27-19	40-28-28-20
	NC	<20	<20	21	28	33	38
18x18	CFM	450	670	900	1120	1345	1570
	Throw	18-13-13-9	24-17-17-12	30-21-21-15	36-25-25-18	42-30-30-21	46-32-32-23
	NC	<20	<20	22	29	34	39
20x20	CFM	555	830	1110	1390	1670	1945
	Throw	20-14-14-10	26-18-18-13	32-22-22-16	40-28-28-20	46-32-32-23	48-34-34-24
	NC	<20	<20	23	30	35	40
22x22	CFM	670	1010	1345	1680	2015	2350
	Throw	22-16-16-11	30-21-21-15	36-25-25-18	44-31-31-22	50-35-35-25	54-38-38-27
	NC	<20	<20	23	31	36	41
24x24	CFM	800	1200	1600	2000	2400	2800
	Throw	24-17-17-12	32-22-22-16	40-28-25-20	48-34-34-24	56-39-39-28	60-42-42-30
	NC	<20	<20	26	32	38	42

Performance Notes:

- All units have been tested in accordance with ANSI / ASHRAE 70-2006. Data in table is derived from such testing.
- Ps – Static pressure required to obtain listed cfm, units of inches water gauge (in. wg.).
- NC – Calculated noise criteria using 10 dB per octave room attenuation (dimensionless).
- Throw – Non-isothermal throw, in feet, for a terminal velocity of 50 fpm.
- Inlet Velocity = fpm (feet per minute).

Model DGSE, DGDF Transfer Door Grille

Size	Area Ak	Inlet Velocity PS	.024	.055	.097	.151	.218	.297	.388	.491	.606
6x6	.25	CFM	50	75	100	125	150	175	200	225	250
	.25	NC	<15	19	23	26	29	32	34	37	39
8x6	.33	CFM	67	100	133	167	200	233	267	300	333
	.33	NC	16	20	24	27	30	33	36	38	40
8x8	.44	CFM	89	133	178	222	267	311	356	400	444
	.44	NC	17	22	25	29	32	34	37	39	42
10x6	.42	CFM	83	125	167	208	250	292	333	375	417
	.41	NC	17	21	25	28	31	34	37	39	41
10x8	.56	CFM	111	167	222	278	333	389	444	500	556
	.54	NC	18	23	26	30	32	35	38	40	43
10x10	.69	CFM	139	208	278	347	417	486	556	625	694
	.68	NC	19	24	27	30	33	36	39	41	44
12x10	.83	CFM	1678	250	333	417	500	583	667	750	833
	.82	NC	20	24	28	31	34	37	40	42	44
12x12	1.00	CFM	200	300	400	500	600	700	800	900	1000
	.98	NC	21	25	29	32	35	38	40	43	45
14x12	1.17	CFM	233	350	467	583	700	817	933	1050	1167
	1.14	NC	21	26	29	33	36	38	41	43	46
14x14	1.36	CFM	272	408	544	681	817	953	1089	1225	1361
	1.33	NC	22	26	30	33	36	39	42	44	46
16x12	1.33	CFM	267	400	533	667	800	933	1067	1200	1333
	1.31	NC	22	26	30	33	36	39	42	44	46
16x16	1.78	CFM	356	533	711	889	1067	1244	1422	1600	1778
	1.74	NC	23	28	31	35	38	40	43	45	48

Size	Area Ak	Inlet Velocity PS	.024	.055	.097	.151	.218	.297	.388	.491	.606
18x12	1.5	CFM	300	450	600	750	900	1050	1200	1350	1500
	1.47	NC	23	27	31	34	37	40	42	45	47
18x18	2.25	CFM	450	675	900	1125	1350	1575	1800	2025	2250
	2.21	NC	24	29	32	36	39	41	44	46	49
20x12	1.67	CFM	333	500	667	833	1000	1167	1333	1500	1667
	1.63	NC	23	27	31	34	37	40	43	45	47
20x20	2.78	CFM	556	833	1111	1389	1667	1944	2222	2500	2778
	2.72	NC	25	30	33	36	39	42	45	47	50
24x12	2.00	CFM	400	600	800	1000	1200	1400	1600	1800	2000
	1.96	NC	24	28	32	35	38	41	43	46	48
24x18	3.00	CFM	600	900	1200	1500	1800	2100	2400	2700	3000
	2.94	NC	26	30	34	37	40	43	45	48	50
24x24	4.00	CFM	800	1200	1600	2000	2400	2800	3200	3600	4000
	3.92	NC	27	31	35	38	41	44	46	49	51
30x12	2.50	CFM	500	750	1000	1250	1500	1750	2000	2250	2500
	2.45	NC	25	29	33	36	39	42	44	47	49
30x20	1.17	CFM	833	1250	1667	2083	2500	2917	3333	3750	4167
	4.08	NC	27	31	35	38	41	44	47	49	51
30x24	5.00	CFM	1000	1500	2000	2500	3000	3500	4000	4500	5000
	4.90	NC	28	32	36	39	42	45	47	50	52
30x30	6.25	CFM	1250	1875	2500	3125	3750	4375	5000	5625	6250
	6.13	NC	29	33	37	40	43	46	48	51	53
		Throw	N/A	N/A	N/A	N/A	N/A	N/A	N/A	N/A	N/A

Performance Notes:

- All units have been tested in accordance with ANSI / ASHRAE 70-2006. Data in table is derived from such testing.
- Ps – Static pressure required to obtain listed cfm, units of inches water gauge (in. wg.).
- NC – Calculated noise criteria using 10 dB per octave room attenuation (dimensionless).
- Throw – Non-isothermal throw, in feet, for a terminal velocity of 50 fpm.
- Inlet Velocity = fpm (feet per minute).

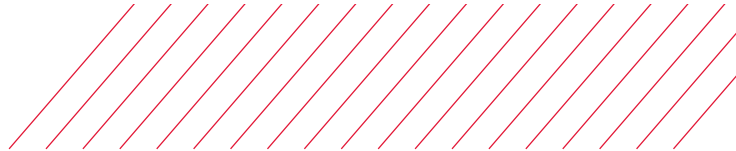

Model CC5, CC5F, CC5TB, CC5DTB, CC5FTB, CC5FTBI, CC520F, CC5C0

Cube Core Return / Return Filter

Size	Area	Inlet Velocity	Throw									
			200	300	400	500	600	700	800	900	1000	
	Ak	PS	.004	.008	.014	.022	.032	.044	.057	.072	.089	
6x6	.25	CFM	50	75	100	125	150	175	200	225	250	
	.25	NC	<15	<15	<15	<15	<15	<15	<15	16	19	
8x6	.33	CFM	67	100	133	167	200	233	267	300	333	
	.33	NC	<15	<15	<15	<15	<15	<15	<15	17	20	
8x8	.44	CFM	89	133	178	222	267	311	356	400	444	
	.44	NC	<15	<15	<15	<15	<15	<15	15	18	21	
10x6	.42	CFM	83	125	167	208	250	292	333	375	417	
	.41	NC	<15	<15	<15	<15	<15	<15	15	18	21	
10x8	.56	CFM	111	167	222	278	333	389	444	500	556	
	.54	NC	<15	<15	<15	<15	<15	<15	16	19	22	
10x10	.69	CFM	139	208	278	347	417	486	556	625	694	
	.68	NC	<15	<15	<15	<15	<15	<15	17	20	23	
12x6	.50	CFM	100	150	200	250	300	350	400	450	500	
	.49	NC	<15	<15	<15	<15	<15	<15	16	19	22	
12x8	.67	CFM	133	200	267	333	400	467	533	600	667	
	.65	NC	<15	<15	<15	<15	<15	<15	16	19	22	
12x10	.83	CFM	167	250	333	417	500	583	667	750	833	
	.82	NC	<15	<15	<15	<15	<15	15	18	21	24	
12x12	1.00	CFM	200	300	400	500	600	700	800	900	1000	
	.98	NC	<15	<15	<15	<15	<15	16	19	22	25	
14x6	.58	CFM	117	175	233	292	350	408	467	525	583	
	.57	NC	<15	<15	<15	<15	<15	<15	17	19	22	
14x8	.78	CFM	156	233	311	389	467	544	622	700	778	
	.76	NC	<15	<15	<15	<15	<15	15	18	21	24	
14x14	1.36	CFM	272	408	544	681	817	953	1089	1225	1361	
	1.33	NC	<15	<15	<15	<15	<15	17	20	23	26	
16x16	1.78	CFM	356	533	711	889	1067	1244	1422	1600	1778	
	1.74	NC	<15	<15	<15	<15	16	19	21	24	27	
18x18	2.25	CFM	450	675	900	1125	1350	1575	1800	2025	2250	
	2.21	NC	<15	<15	<15	<15	17	20	22	25	28	
20x12	1.67	CFM	333	500	667	833	1000	1167	1333	1500	1667	
	1.62	NC	<15	<15	<15	<15	16	18	21	24	27	
20x20	2.78	CFM	556	833	1111	1389	1667	1944	2222	2500	2778	
	2.72	NC	<15	<15	<15	15	18	21	23	26	29	
22x22	3.36	CFM	672	1008	1334	1681	2017	2353	2689	3025	3361	
	3.29	NC	<15	<15	<15	16	19	21	24	27	30	
24x12	2.00	CFM	400	600	800	1000	1200	1400	1600	1800	2000	
	1.96	NC	<15	<15	<15	<15	16	19	22	25	28	
24x14	2.33	CFM	467	700	933	1167	1400	1633	1867	2100	2333	
	2.29	NC	<15	<15	<15	<15	17	20	23	26	28	
24x24	4.00	CFM	800	1200	1600	2000	2400	2800	3200	3600	4000	
	3.96	NC	<15	<15	<15	17	19	22	25	28	31	
26x4	.72	CFM	144	217	289	361	433	506	578	650	722	
	1.06	NC	<15	<15	<15	<15	<15	<15	18	20	23	
48x24	8.00	CFM	1600	2400	3200	4000	4800	5600	6400	7200	8000	
	7.84	NC	<15	<15	17	20	22	25	28	31	34	
		Throw	N/A	N/A	N/A	N/A	N/A	N/A	N/A	N/A	N/A	

Model SRH, SRHF, RH, RHD, RHF, RHE, RHED, RHEF, SRH-6, SRHF-6, SRHF-6, SRH20F, RHTB, RHFTB, RHFTBI, RH20F, RHETB, RHEFTB, RHEFTBI

Fixed Bar Return / Return Air Filter Grille

Size	Area	Inlet Velocity	Throw											
			200	300	400	500	600	700	800	900	1000			
	Ak	PS	.005	.011	.020	.031	.045	.061	.080	.101	.125			
6x6	.25	CFM	50	75	100	125	150	175	200	225	250			
	.12	NC	<15	<15	<15	17	20	22	25	27	29			
8x4	.22	CFM	44	67	89	111	133	156	178	200	222			
	.11	NC	<15	<15	<15	16	19	22	24	27	29			
8x6	.33	CFM	67	100	133	167	200	233	267	300	333			
	.16	NC	<15	<15	<15	18	21	24	26	29	31			
8x8	.44	CFM	89	133	178	222	267	311	356	400	444			
	.22	NC	<15	<15	16	19	22	25	27	30	32			
10x10	.69	CFM	139	208	278	347	417	486	556	625	694			
	.68	NC	<15	<15	18	21	24	27	29	32	34			
12x6	.50	CFM	100	150	200	250	300	350	400	450	500			
	.49	NC	<15	<15	17	20	23	25	28	30	32			
12x12	1.00	CFM	200	300	400	500	600	700	800	900	1000			
	.98	NC	<15	16	20	23	26	28	31	33	35			
14x6	.58	CFM	117	175	233	292	350	408	467	525	583			
	.57	NC	<15	<15	17	21	23	26	29	31	33			
14x8	.78	CFM	156	233	311	389	467	544	622	700	778			
	.76	NC	<15	<15	19	22	25	27	30	32	34			
14x10	.97	CFM	194	292	389	486	583	681	778	875	972			
	.95	NC	<15	16	19	23	26	28	31	33	35			
14x14	1.36	CFM	272	408	544	681	817	953	1089	1225	1361			
	1.33	NC	<15	17	21	24	27	30	32	35	37			
16x12	1.33	CFM	267	400	533	667	800	933	1067	1200	1333			
	1.31	NC	<15	17	21	24	27	30	32	35	37			
20x12	1.67	CFM	333	500	667	833	1000	1167	1333	1500	1667			
	1.63	NC	<15	18	22	25	28	31	33	35	38			
20x14	1.94	CFM	389	583	778	972	1167	1361	1556	1750	1944			
	1.91	NC	<15	19	22	26	29	31	34	36	38			
20x20	2.78	CFM	556	833	1111	1389	1667	1944	2222	2500	2778			
	2.72	NC	16	20	24	27	30	33	35	38	40			
24x8	1.33	CFM	267	400	533	667	800	933	1067	1200	1333			
	1.31	NC	<15	17	21	24	27	30	32	35	37			
24x12	2.00	CFM	400	600	800	1000	1200	1400	1600	1800	2000			
	1.96	NC	<15	19	23	26	32	34	36	38	40			
30x6	1.25	CFM	250	375	500	625	750	875	1000	1125	1250			
	1.23	NC	<15	17	21	24	27	29	32	34	36			
30x12	2.50	CFM	500	750	1000	1250	1500	1750	2000	2250	2500			
	2.45	NC	15	20	24	27	30	32	35	37	39			
30x20	4.17	CFM	833	1250	1667	2083	2500	2917	3333	3750	4167			
	4.08	NC	17	22	26	29	32	35	37	39	42			
36x12	3.00	CFM	600	900	1200	1500	1800	2100	2400	2700	3000			
	2.94	NC	16	21	24	28	31	33	36	38	40			
48x12	4.00	CFM	800	1200	1600	2000	2400	2800	3200	3600	4000			
	3.92	NC	17	22	26	29	32	35	37	39	41			
48x24	8.00	CFM	1600	2400	3200	4000	4800	5600	6400	7200	8000			
	7.84	NC	20	25	29	32	35	38	40	42	44			
		Throw	N/A	N/A	N/A	N/A	N/A	N/A	N/A	N/A	N/A			

Performance Notes:

- All units have been tested in accordance with ANSI / ASHRAE 70-2006. Data in table is derived from such testing.
- Ps – Static pressure required to obtain listed cfm, units of inches water gauge (in. wg.).
- NC – Calculated noise criteria using 10 dB per octave room attenuation (dimensionless).
- Throw – Non-isothermal throw, in feet, for a terminal velocity of 50 fpm.
- Inlet Velocity = fpm (feet per minute).

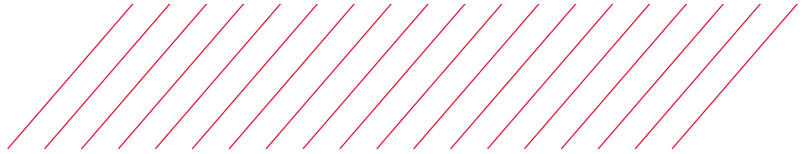

Model 5500 DAF-CC5 Aluminum Concentric Supply / Return

Based on 100% Return of Supply Air for 2 – 10 Ton Roof Packages							
Tonnage	2	2 1/2	3	4	5	7 1/2	10
Capacity (CFM)	800	1000	1200	1600	2000	3000	4000
Supply Neck Size	21x21	21x21	24x24	27x27	30x30	39x39	45x45
Ak	.60	.60	.70	1.10	1.30	2.20	2.60
Vk	1335	1665	1715	1430	1575	1365	1540
Ps	.09	.15	.15	.11	.13	.10	.12
Throw	14	16	17	20	23	31	39
Return Neck Size	15X15	15X15	18X18	18X18	21X21	27X27	33X33
Ak	1.56	1.56	2.25	2.25	3.06	5.06	7.56
Inlet Velocity	513	640	535	710	654	500	529
Ps	.04	.06	.04	.07	.06	.05	.04
NC	25	35	37	30	37	37	38

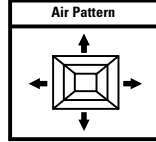

Based on 75% Return of Supply Air								
All Supplies	Face Velocity	500	750	1000	1250	1500	1750	2000
12X12	Total CFM	90	130	175	220	265	310	350
Supply	Throw	4	5	8	10	12	13	14
Ak = .18	NC	<15	16	21	26	31	35	39
9X9	Total CFM	70	100	130	165	200	230	260
Return	Inlet Velocity	125	180	230	295	355	410	465
Ak = .56	Ps	.01	.01	.01	.01	.02	.03	.04
15x15	Total CFM	200	300	400	500	600	700	800
Supply	Throw	5	8	10	12	14	17	19
Ak = .40	NC	<15	16	21	26	35	40	45
9x9	Total CFM	150	225	300	375	450	525	600
Return	Inlet Velocity	265	400	535	670	805	935	1070
Ak = .56	Ps	.01	.02	.04	.06	.09	.12	.16
18x18	Total CFM	250	375	500	625	750	875	1000
Supply	Throw	5	8	11	12	14	16	19
Ak = .50	NC	<15	19	24	29	34	38	42
12x12	Total CFM	190	280	375	470	560	655	750
Return	Inlet Velocity	190	280	375	470	560	655	750
Ak = 1.00	Ps	.01	.01	.02	.03	.04	.06	.08
21x21	Total CFM	300	450	600	750	900	1050	1200
Supply	Throw	5	8	12	13	15	17	20
Ak = .60	NC	15	20	25	30	35	39	43
15x15	Total CFM	225	340	450	560	675	790	900
Return	Inlet Velocity	145	220	290	360	430	505	575
Ak = 1.56	Ps	.01	.01	.01	.02	.03	.04	.05
24x24	Total CFM	350	525	700	875	1050	1225	1400
Supply	Throw	5	8	11	13	16	20	25
Ak = .70	NC	16	21	26	31	36	40	43
18x18	Total CFM	260	395	525	655	790	920	1050
Return	Inlet Velocity	115	175	235	290	350	410	465
Ak = 2.25	Ps	.01	.01	.01	.01	.02	.03	.04

Based on 75% Return of Supply Air								
All Supplies	Face Velocity	500	750	1000	1250	1500	1750	2000
30x30	Total CFM	640	955	1275	1595	1915	2235	2550
Supply	Throw	7	12	16	17	21	25	30
Ak = 1.30	NC	15	20	27	33	38	42	45
21x21	Total CFM	480	715	955	1195	1435	1675	1910
Return	Inlet Velocity	155	235	310	390	470	545	625
Ak = 3.06	Ps	.01	.01	.01	.02	.03	.04	.05
36x36	Total CFM	1000	1500	2000	2500	3000	3500	4000
Supply	Throw	8	13	18	22	30	34	38
Ak = 2.00	NC	15	20	28	34	39	43	47
24x24	Total CFM	750	1125	1500	1875	2250	2625	3000
Return	Inlet Velocity	185	280	375	470	560	655	750
Ak = 4.00	Ps	.01	.01	.02	.03	.05	.06	.08
42x42	Total CFM	1440	2160	2875	3595	4315	5035	5750
Supply	Throw	10	21	28	34	39	43	49
Ak = 2.90	NC	17	23	30	36	41	45	48
27x27	Total CFM	1080	1615	2160	2695	3235	3775	4310
Return	Inlet Velocity	215	320	425	530	640	745	850
Ak = 6.25	Ps	.01	.01	.03	.04	.06	.08	.10
48x48	Total CFM	1690	2530	3380	4220	5065	5910	6750
Supply	Throw	11	23	24	30	41	48	55
Ak = 2.60	NC	16	23	32	37	41	45	49
33x33	Total CFM	1265	1900	2530	3165	3800	4430	5065
Return	Inlet Velocity	170	250	335	420	500	585	670
Ak = 7.56	Ps	.01	.01	.02	.03	.04	.05	.06
60x60	Total CFM	2190	3280	4375	5470	6565	7660	8750
Supply	Throw	13	25	28	32	43	50	56
Ak = 4.37	NC	21	28	32	35	38	41	46
45x45	Total CFM	1640	2460	3280	4100	4925	5745	6565
Return	Inlet Velocity	115	175	235	290	350	410	465
Ak = 14.06	Ps	.002	.004	.007	.01	.02	.025	.03

PERFORMANCE DATA

Model 5500 SI Steel Square Louver Face / Insulated

Module Size	Neck Size	Neck Velocity		200	300	400	500	600	700	800	900
		CFM	Ps	.032	.060	.094	.133	.176	.224	.275	.330
24x24	6"	CFM		40	60	80	100	120	135	155	175
		Throw		5	7	8	8	9	10	11	11
		NC		<15	<15	<15	18	23	26	32	34
24x24	8"	CFM		70	105	140	175	210	245	280	315
		Throw		7	9	10	11	12	13	14	15
		NC		<15	<15	<15	21	26	30	34	37
24x24	10"	CFM		110	165	220	275	325	380	435	490
		Throw		9	11	13	15	16	17	18	20
		NC		<15	<15	17	23	28	32	35	38
24x24	12"	CFM		155	235	315	395	470	550	630	705
		Throw		11	14	16	18	19	21	22	23
		NC		<15	<15	18	23	26	31	36	39
24x24	14"	CFM		215	320	430	535	640	750	855	960
		Throw		13	16	18	21	23	24	26	28
		NC		<15	16	23	26	31	37	39	43
24x24	15"	CFM		245	370	490	615	735	860	980	1105
		Throw		13	17	20	22	24	26	28	30
		NC		<15	17	23	29	34	38	40	43

Performance Notes

- All units have been tested in accordance with ANSI / ASHRAE 70-2006. Data in table is derived from such testing.
- Ps – Static pressure required to obtain listed cfm, units of inches water gauge (in. wg.).
- NC – Calculated noise criteria using 10 dB per octave room attenuation (dimensionless).
- Throw – Non-isothermal throw, in feet, for a terminal velocity of 50 fpm.
- Inlet Velocity = fpm (feet per minute).

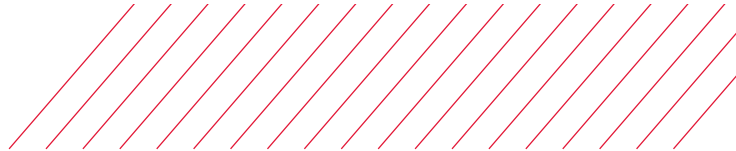

Model 4700, 4700D, 4706, 4706D, 5906
Steel 2-Cone Louver Face

Panel Size	Neck Size	Area Ak	Inlet Velocity	400	500	600	700	800	900	1000	1200
24x24	6"	.20	CFM	80	100	120	135	155	175	195	235
			Ps	.014	.021	.031	.039	.051	.065	.081	.118
		.093	Throw	5	5	6	6	6	7	7	8
			NC	<15	<15	<15	<15	<15	16	18	23
24x24	8"	.20	CFM	140	175	210	245	280	315	350	420
			Ps	.016	.025	.036	.048	.063	.080	.099	.142
		.093	Throw	6	7	7	8	9	9	10	10
			NC	<15	<15	<15	<15	<15	16	18	21
24x24	10"	.20	CFM	220	275	325	380	435	490	545	655
			Ps	.019	.030	.042	.057	.075	.096	.118	.171
		.093	Throw	8	8	9	10	11	11	12	13
			NC	<15	<15	<15	<15	<15	16	20	24
24x24	12"	.20	CFM	315	395	470	55	63	725	785	940
			Ps	.021	.033	.046	.063	.083	.104	.129	.185
		.093	Throw	9	10	11	12	13	14	14	16
			NC	<15	<15	<15	<15	19	23	27	33
24x24	14"	.20	CFM	430	535	640	750	855	960	1070	1285
			Ps	.026	.041	.058	.080	.104	.131	.163	.234
		.093	Throw	11	12	13	14	15	16	17	18
			NC	<15	<15	<15	<15	18	23	28	35
24x24	15"	.20	CFM	490	615	735	860	980	1105	1225	1475
			Ps	.032	.051	.072	.099	.129	.164	.201	.292
		.093	Throw	11	13	14	16	16	17	18	20
			NC	<15	<15	<15	16	22	27	31	39

Model 4800, 4800D, 4806, 4806D, 5906-3
Steel 3-Cone Louver Face

Panel Size	Neck Size	Area Ak	Inlet Velocity	400	500	600	700	800	900	1000	1200
24x24	6"	.20	CFM	80	100	120	135	155	175	195	235
			Ps	.013	.020	.029	.037	.048	.061	.076	.111
		.093	Throw	5	6	7	7	7	8	8	9
			NC	<15	<15	<15	<15	<15	18	21	25
24x24	8"	.20	CFM	140	175	210	245	280	315	350	420
			Ps	.014	.022	.032	.043	.056	.071	.088	.126
		.093	Throw	7	8	9	9	10	11	11	12
			NC	<15	<15	<15	<15	<15	17	21	24
24x24	10"	.20	CFM	220	275	325	380	435	490	545	655
			Ps	.018	.028	.039	.053	.070	.088	.109	.158
		.093	Throw	9	10	11	12	12	13	14	15
			NC	<15	<15	<15	<15	19	23	27	33
24x24	12"	.20	CFM	315	395	470	55	63	725	785	940
			Ps	.022	.035	.049	.067	.088	.111	.137	.197
		.093	Throw	11	12	12	14	15	16	17	18
			NC	<15	<15	<15	16	21	26	30	36
24x24	14"	.20	CFM	430	535	640	750	855	960	1070	1285
			Ps	.032	.049	.071	.097	.126	.159	.198	.285
		.093	Throw	12	14	15	16	17	18	19	21
			NC	<15	<15	<15	17	22	27	32	39
24x24	15"	.20	CFM	490	615	735	860	980	1105	1225	1475
			Ps	.036	.056	.080	.109	.142	.181	.222	.322
		.093	Throw	13	15	16	17	19	20	21	23
			NC	<15	<15	<15	16	22	27	31	39

Model 4750, 4750D, 4756, 4756D, 5956
Steel Square Plaque Face

Panel Size	Neck Size	Area Ak	Inlet Velocity	400	500	600	700	800	900	1000	1200
24x24	6"	.20	CFM	80	100	120	135	155	175	195	235
			Ps	.003	.004	.006	.006	.008	.011	.014	.021
			Throw	4	6	7	8	8	9	9	10
			NC	<15	<15	<15	<15	15	18	21	26
24x24	8"	.20	CFM	140	175	210	245	280	315	350	420
			Ps	.007	.012	.017	.023	.030	.038	.047	.067
			Throw	6	7	9	10	11	12	13	14
			NC	<15	<15	<15	17	21	25	28	34
24x24	10"	.20	CFM	220	275	325	380	435	490	545	655
			Ps	.016	.025	.034	.047	.061	.078	.096	.139
			Throw	7	9	11	13	14	15	16	17
			NC	<15	<15	15	21	26	30	33	37
24x24	12"	.20	CFM	315	395	470	55	63	725	785	940
			Ps	.027	.042	.059	.081	.107	.133	.165	.236
			Throw	9	11	13	15	17	18	19	21
			NC	<15	<15	17	22	27	30	33	38
24x24	14"	.20	CFM	430	535	640	750	855	960	1070	1285
			Ps	.031	.049	.069	.095	.124	.156	.194	.280
			Throw	10	13	15	18	20	21	22	24
			NC	<15	<15	20	25	30	33	36	40
24x24	15"	.20	CFM	490	615	735	860	980	1105	1225	1475
			Ps	.038	.060	.086	.117	.152	.194	.238	.345
			Throw	11	14	16	19	21	23	24	26
			NC	<15	<15	20	27	32	35	37	41

Performance Notes:

1. (4700-4706) / (4750-4756) / (4800-4806-4806D) / (5906).
2. All units have been tested in accordance with ANSI / ASHRAE 70-2006. Data in table is derived from such testing.
3. Ps – Static pressure required to obtain listed cfm, units of inches water gauge (in. wg.).
4. NC – Calculated noise criteria using 10 dB per octave room attenuation (dimensional).
5. Throw – Non-isothermal horizontal throw, in feet, for a terminal velocity of 50 fpm.
6. Ak – Area Factors.
7. Inlet Velocity = fpm (feet per minute).

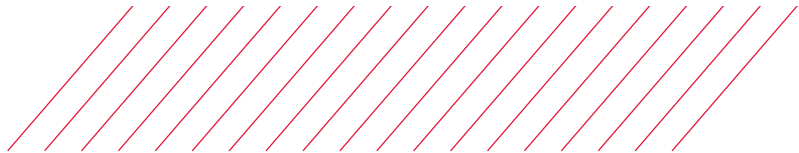
Model 6650 1/2" Slot – CFM Per Linear Foot

Slots	Static Pressure	Horizontal Vertical	.005 .004	.021 .015	.047 .033	.083 .058	.130 .091	.188 .132	.255 .179	.334 .234	.422 .295	.521 .365
1	CFM/LF		5	10	15	20	25	30	335	40	45	50
	Horizontal Throw , Ft		6	12	14	17	19	20	22	24	25	26
	Vertical Throw , Ft		2	7	9	11	12	13	14	15	16	17
	Horizontal NC		<15	<15	<15	17	22	27	30	34	36	38
	Vertical NC		<15	<15	<15	<15	<15	15	18	22	24	26
2	CFM/LF		10	20	30	40	50	60	70	80	90	100
	Horizontal Throw , Ft		8	17	20	24	26	29	31	33	35	37
	Vertical Throw , Ft		3	9	13	15	17	18	20	21	23	24
	Horizontal NC		<15	<15	<15	20	25	30	33	37	39	41
	Vertical NC		<15	<15	<15	<15	<15	18	21	25	27	29
3	CFM/LF		15	30	45	60	75	90	105	120	135	150
	Horizontal Throw , Ft		13	20	25	29	32	35	38	41	43	45
	Vertical Throw , Ft		5	11	16	18	21	23	24	26	28	29
	Horizontal NC		<15	<15	15	22	27	32	35	39	41	43
	Vertical NC		<15	<15	<15	<15	15	20	23	27	29	31
4	CFM/LF		20	40	60	80	100	120	140	160	180	200
	Horizontal Throw , Ft		15	24	29	33	37	41	44	47	50	53
	Vertical Throw , Ft		5	13	18	21	24	26	28	30	32	34
	Horizontal NC		<15	<15	17	24	29	33	36	40	42	44
	Vertical NC		<15	<15	<15	<15	17	21	24	28	30	32
5	CFM/LF		25	50	75	100	125	150	175	200	225	250
	Horizontal Throw , Ft		16	25	32	37	42	46	49	53	56	59
	Vertical Throw , Ft		6	19	23	26	29	32	34	37	39	41
	Horizontal NC		<15	<15	19	26	31	35	37	41	43	45
	Vertical NC		<15	<15	<15	<15	19	23	25	29	31	33
6	CFM/LF		30	60	90	120	150	180	210	240	270	300
	Horizontal Throw , Ft		20	29	35	41	46	50	54	58	61	65
	Vertical Throw , Ft		6	16	23	26	29	32	34	37	39	41
	Horizontal NC		<15	17	20	27	32	36	38	42	44	46
	Vertical NC		<15	<15	<15	15	20	24	26	30	32	35
7	CFM/LF		35	70	105	140	175	210	245	280	315	350
	Horizontal Throw , Ft		18	31	38	44	49	54	59	63	66	70
	Vertical Throw , Ft		7	17	24	28	31	34	37	40	42	45
	Horizontal NC		<15	18	21	28	33	37	39	43	45	47
	Vertical NC		<15	<15	<15	16	21	25	31	33	35	37
8	CFM/LF		40	80	120	160	200	240	280	320	360	400
	Horizontal Throw , Ft		19	33	41	47	53	58	63	67	71	75
	Vertical Throw , Ft		7	18	26	30	34	37	40	43	45	48
	Horizontal NC		<15	20	22	29	34	39	40	44	45	48
	Vertical NC		<15	<15	<15	17	22	27	28	32	34	36

Performance Notes:

- On units without plenums, pressure drop reported is across the diffuser element only. The field supply pressure drop should be included when determining system fan requirements. A good approximation of the static pressure requirements can be calculated by adding the velocity pressure through the plenum inlet to the diffuser section pressure drop.
- NC is based on a 4-ft. section of diffuser. The following table should be used to calculate sound levels for lengths other than 4 ft.
- To correct throws for lengths other than the 4-ft. lengths used in determining catalog performance, throws should be adjusted per the following table:

NC Correction for Length					
Length (feet)	2	4	6	8	10
NC Correction	-2	+0	+2	+3	+5
Throw Correction Multiplier for Length					
Length (feet)	2	4	8	10	12
Throw Correction	0.7	1.0	1.5	1.7	1.8

- All pressures are in inches of water.
- Isothermal throw is given for terminal velocity 50 fpm, based on 4 ft. section.
- Vertical throw values are based on a 50 fpm terminal velocity.
- For vertical supply, subtract one NC.
- For return minus pattern controllers, deduct 12 NC.
- Throw values are based on a 1-way discharge from the slot. For 2-way discharges, throw is based upon the number and size of the slots throwing in each direction, with the total supply air flow split equally between all slots in the units.
- Data were collected in accordance to ASHRAE Standard 70-1991 "Method of Testing for Rating in the Performance of Air Outlets and Inlets."



Model 6675 3/4" Slot – CFM Per Linear Foot

Slots	Static Pressure	Horizontal Vertical	.011 .007	.024 .014	.042 .025	.066 .040	.095 .057	.129 .077	.168 .101	.213 .128	.263 .158	.318 .191
1	CFM/LF		10	15	20	25	30	35	40	45	50	55
	Horizontal Throw , Ft		6	14	22	24	27	29	31	33	35	36
	Vertical Throw , Ft		2	6	10	12	13	14	15	16	17	18
	Horizontal NC		<15	<15	<15	15	19	23	25	28	31	33
	Vertical NC		<15	<15	<15	<15	<15	<15	<15	16	19	21
2	CFM/LF		20	30	40	50	60	70	80	90	100	110
	Horizontal Throw , Ft		10	22	29	35	38	41	44	46	49	51
	Vertical Throw , Ft		4	8	14	17	18	20	21	23	24	25
	Horizontal NC		<15	<15	<15	18	22	26	28	31	34	36
	Vertical NC		<15	<15	<15	<15	<15	<15	16	19	22	24
3	CFM/LF		30	45	60	75	90	105	120	135	150	165
	Horizontal Throw , Ft		13	27	36	41	44	48	51	54	57	60
	Vertical Throw , Ft		4	10	17	21	23	24	26	28	29	31
	Horizontal NC		<15	<15	<15	20	24	28	30	33	35	37
	Vertical NC		<15	<15	<15	<15	<15	16	18	21	23	25
4	CFM/LF		40	60	80	100	120	140	160	180	200	220
	Horizontal Throw , Ft		24	36	42	47	51	55	59	63	66	70
	Vertical Throw , Ft		5	11	20	24	26	28	30	32	34	36
	Horizontal NC		<15	15	16	22	25	30	31	35	37	39
	Vertical NC		<15	<15	<15	<15	<15	18	19	23	25	27
5	CFM/LF		50	75	100	125	150	175	200	225	250	275
	Horizontal Throw , Ft		30	41	47	52	57	62	66	70	74	78
	Vertical Throw , Ft		6	13	22	27	29	31	34	36	38	39
	Horizontal NC		<15	16	17	23	26	32	33	36	38	40
	Vertical NC		<15	<15	<15	<15	<15	20	21	24	26	28
6	CFM/LF		60	90	120	150	180	210	240	270	300	330
	Horizontal Throw , Ft		29	44	51	57	63	68	73	77	81	85
	Vertical Throw , Ft		6	14	24	29	32	34	37	39	41	43
	Horizontal NC		<15	17	19	24	28	33	34	37	39	41
	Vertical NC		<15	<15	<15	<15	16	21	22	25	27	29
7	CFM/LF		70	105	140	175	210	245	280	315	350	385
	Horizontal Throw , Ft		32	48	55	63	68	73	78	83	88	92
	Vertical Throw , Ft		7	15	26	31	34	37	40	42	45	47
	Horizontal NC		16	18	20	24	29	34	35	38	40	42
	Vertical NC		<15	<15	<15	<15	17	22	23	26	28	30
8	CFM/LF		80	120	160	200	240	280	320	360	400	440
	Horizontal Throw , Ft		34	51	59	66	73	78	84	89	94	99
	Vertical Throw , Ft		7	16	28	34	37	40	43	45	48	50
	Horizontal NC		18	19	22	25	30	35	37	39	41	43
	Vertical NC		<15	<15	<15	<15	18	23	25	27	29	31

Performance Notes:

- On units without plenums, pressure drop reported is across the diffuser element only. The field supply pressure drop should be included when determining system fan requirements. A good approximation of the static pressure requirements can be calculated by adding the velocity pressure through the plenum inlet to the diffuser section pressure drop.
- NC is based on a 4-ft. section of diffuser. The following table should be used to calculate sound levels for lengths other than 4 ft.
- To correct throws for lengths other than the 4-ft. lengths used in determining catalog performance, throws should be adjusted per the following table:

NC Correction for Length					
Length (feet)	2	4	6	8	10
NC Correction	-2	+0	+2	+3	+5
Throw Correction Multiplier for Length					
Length (feet)	2	4	8	10	12
Throw Correction	0.7	1.0	1.5	1.7	1.8

- All pressures are in inches of water.
- Isothermal throw is given for terminal velocity 50 fpm, based on 4-ft. section.
- Vertical throw values are based on a 50 fpm terminal velocity.
- For vertical supply, subtract one NC.
- For return minus pattern controllers, deduct 12 NC.
- Throw values are based on a 1-way discharge from the slot. For 2-way discharges, throw is based upon the number and size of the slots throwing in each direction, with the total supply air flow split equally between all slots in the units.
- Data were collected in accordance to ASHRAE Standard 70-1991 "Method of Testing for Rating in the Performance of Air Outlets and Inlets."

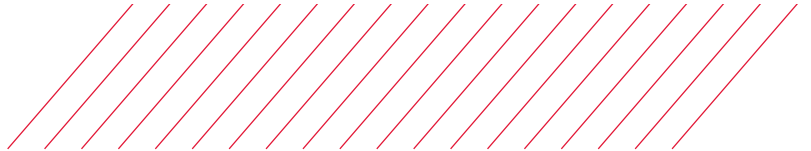

Model 6610 1" Slot – CFM Per Linear Foot

Slots	Static Pressure	Horizontal Vertical	.008 .003	.030 .012	.047 .020	.068 .028	.092 .037	.120 .040	.152 .061	.188 .076	.227 .092	.270 .109
1	CFM/LF		10	20	25	30	35	40	45	50	55	60
	Horizontal Throw , Ft		6	22	24	27	29	31	33	35	36	38
	Vertical Throw , Ft		2	10	12	13	14	15	16	17	18	19
	Horizontal NC		<15	<15	<15	<15	19	22	24	26	28	30
	Vertical NC		<15	<15	<15	<15	<15	<15	<15	<15	16	18
2	CFM/LF		20	40	50	60	70	80	90	100	110	120
	Horizontal Throw , Ft		10	29	35	38	41	44	46	49	51	54
	Vertical Throw , Ft		4	14	17	18	20	21	23	24	25	26
	Horizontal NC		<15	<15	<15	<15	21	25	27	29	31	33
	Vertical NC		<15	<15	<15	<15	<15	<15	15	17	19	21
3	CFM/LF		30	60	75	90	105	120	135	150	165	180
	Horizontal Throw , Ft		18	36	41	44	48	51	54	57	60	63
	Vertical Throw , Ft		4	17	21	23	24	26	28	29	31	32
	Horizontal NC		<15	<15	<15	17	22	27	28	30	32	34
	Vertical NC		<15	<15	<15	<15	<15	15	16	18	20	22
4	CFM/LF		40	80	100	120	140	160	180	200	220	240
	Horizontal Throw , Ft		24	42	47	51	55	59	63	66	70	73
	Vertical Throw , Ft		5	20	24	26	28	30	32	34	35	37
	Horizontal NC		<15	<15	15	19	24	29	30	32	34	36
	Vertical NC		<15	<15	<15	<15	<15	17	18	20	22	24
5	CFM/LF		50	100	125	150	175	200	225	250	275	300
	Horizontal Throw , Ft		30	47	52	57	62	66	70	74	78	81
	Vertical Throw , Ft		6	24	29	32	34	37	39	41	43	45
	Horizontal NC		<15	<15	16	21	25	31	32	34	35	37
	Vertical NC		<15	<15	<15	<15	<15	19	20	22	23	25
6	CFM/LF		60	120	150	180	210	240	270	300	330	360
	Horizontal Throw , Ft		29	51	57	63	68	73	77	81	85	89
	Vertical Throw , Ft		6	24	29	32	34	37	39	41	43	45
	Horizontal NC		<15	15	17	22	27	33	34	35	36	38
	Vertical NC		<15	<15	<15	<15	<15	21	22	23	24	26
7	CFM/LF		70	140	175	210	245	280	315	350	385	420
	Horizontal Throw , Ft		32	55	62	68	73	78	83	88	92	96
	Vertical Throw , Ft		7	26	31	34	37	40	42	45	47	49
	Horizontal NC		<15	16	18	24	28	34	36	37	38	39
	Vertical NC		<15	<15	<15	<15	16	22	24	25	26	27
8	CFM/LF		80	160	200	240	280	320	360	400	440	480
	Horizontal Throw , Ft		34	59	66	73	78	84	89	94	98	103
	Vertical Throw , Ft		7	28	34	37	40	43	45	48	50	52
	Horizontal NC		<15	16	20	26	30	35	37	38	39	41
	Vertical NC		<15	<15	<15	<15	18	23	25	26	27	29

Performance Notes:

- On units without plenums, pressure drop reported is across the diffuser element only. The field supply pressure drop should be included when determining system fan requirements. A good approximation of the static pressure requirements can be calculated by adding the velocity pressure through the plenum inlet to the diffuser section pressure drop.
- NC is based on a 4-ft. section of diffuser. The following table should be used to calculate sound levels for lengths other than 4 ft.
- To correct throws for lengths other than the 4-ft. lengths used in determining catalog performance, throws should be adjusted per the following table:

NC Correction for Length					
Length (feet)	2	4	6	8	10
NC Correction	-2	+0	+2	+3	+5
Throw Correction Multiplier for Length					
Length (feet)	2	4	8	10	12
Throw Correction	0.7	1.0	1.5	1.7	1.8

- All pressures are in inches of water.
- Isothermal throw is given for terminal velocity 50 fpm, based on 4-ft section.
- Vertical throw values are based on a 50 fpm terminal velocity.
- For vertical supply, subtract one NC.
- For return minus pattern controllers, deduct 12 NC.
- Throw values are based on a 1-way discharge from the slot. For 2-way discharges, throw is based upon the number and size of the slots throwing in each direction, with the total supply air flow split equally between all slots in the units.
- Data were collected in accordance to ASHRAE Standard 70-1991 "Method of Testing for Rating in the Performance of Air Outlets and Inlets."

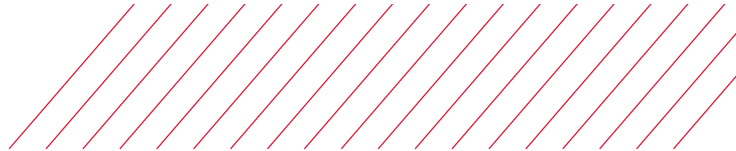

Model PHPS-6, PHPSI-6 One Slot

		CFM/LF	1/2" Slot Width										CFM/LF	1" Slot Width							
			10	15	25	40	60	75	90	120				10	15	25	40	60	75	90	120
3/4" Slot Width	2' Length 8" Inlet	Horizontal	CFM	20	30	50	80	120	150	180	240	Horizontal	CFM	20	30	50	80	120	150	180	240
			PS	.010	.023	.064	.163	.367	.574	.826	1.469		PS	.005	.010	.028	.073	.163	.255	.368	.654
			Throw	6	8	10	12	15	17	19	22		Throw	6	7	9	11	14	15	17	19
		Vertical	NC	<10	<10	17	29	39	43	47	56	Vertical	NC	<10	<10	10	23	32	36	39	44
			PS	.013	.029	.082	.209	.471	.736	1.060	1.885		PS	.007	.016	.044	.113	.254	.396	.571	1.015
			Throw	3	4	7	11	16	20	24	32		Throw	1	2	4	6	9	11	13	18
	4' Length 8" Inlet	Horizontal	CFM	40	60	100	160	240	300	360	Horizontal	CFM	40	60	100	160	240	300	360	480	
			PS	.010	.023	.063	.160	.360	.563	.81		PS	.004	.010	.028	.071	.160	.250	.361	.641	
			Throw	7	10	14	18	22	24	26		Throw	4	7	11	16	19	22	24	28	
		Vertical	NC	<10	<10	20	32	42	46	50	Vertical	NC	<10	<10	13	26	35	39	42	47	
			PS	.013	.029	.080	.205	.462	.722	1.039		PS	.007	.016	.043	.111	.249	.389	.560	.995	
			Throw	5	8	13	20	30	38	46		Throw	3	5	8	13	19	24	29	38	
3/4" Slot Width	2' Length 8" Inlet	Horizontal	CFM	20	30	50	80	120	150	180	240	Horizontal	CFM	20	30	50	80	120	150	180	240
			PS	.007	.015	.041	.104	.235	.367	.528	.939		PS	.004	.010	.027	.069	.155	.242	.349	.620
			Throw	5	7	9	12	14	16	17	20		Throw	3	5	8	11	13	15	16	18
		Vertical	NC	<10	<10	<10	23	32	37	40	47	Vertical	NC	<10	<10	<10	13	22	29	34	42
			PS	.008	.017	.048	.123	.277	.433	.623	1.108		PS	.003	.007	.020	.052	.117	.183	.263	.468
			Throw	2	3	5	9	13	16	20	26		Throw	1	2	3	4	7	8	10	13
	4' Length 8" Inlet	Horizontal	CFM	40	60	100	160	240	300	360	Horizontal	CFM	40	60	100	160	240	300	360	480	
			PS	.006	.014	.040	.102	.230	.360	.518		PS	.004	.009	.026	.068	.152	.237	.342	.608	
			Throw	6	8	13	16	20	22	25		Throw	5	7	12	15	18	21	23	26	
		Vertical	NC	<10	<10	15	26	35	40	43	Vertical	NC	<10	<10	<10	16	25	32	37	45	
			PS	.008	.017	.047	.121	.272	.424	.611		PS	.003	.007	.020	.051	.115	.179	.258	.458	
			Throw	4	6	10	17	25	31	37		Throw	2	4	6	10	14	18	21	29	
4' Length 8" Inlet	Horizontal	CFM	40	60	100	160	240	300	360	Horizontal	CFM	40	60	100	160	240	300	360	480		
		PS	.006	.014	.040	.102	.230	.360	.518		PS	.004	.009	.026	.068	.152	.237	.342	.608		
		Throw	6	8	13	16	20	22	25		Throw	5	7	12	15	18	21	23	26		
	Vertical	NC	<10	<10	15	26	35	40	43	Vertical	NC	<10	<10	<10	16	25	32	37	45		
		PS	.008	.017	.047	.121	.272	.424	.611		PS	.003	.007	.020	.051	.115	.179	.258	.458		
		Throw	4	6	10	17	25	31	37		Throw	2	4	6	10	14	18	21	29		

Model PHPS-6, PHPSI-6 Two Slot

		CFM/LF	1/2" Slot Width										CFM/LF	1" Slot Width							
			10	15	25	40	60	75	90	120				10	15	25	40	60	75	90	120
3/4" Slot Width	2' Length 8" Inlet	Horizontal	CFM	20	30	50	80	120	150	180	240	Horizontal	CFM	20	30	50	80	120	150	180	240
			PS	.005	.012	.032	.083	.186	.291	.419	.745		PS	.002	.005	.014	.035	.080	.124	.179	.318
			Throw	3	5	8	13	17	19	21	24		Throw	3	4	7	12	17	19	21	24
		Vertical	NC	<10	<10	<10	15	26	32	37	43	Vertical	NC	<10	<10	<10	<10	17	24	29	35
			PS	.005	.011	.029	.075	.169	.264	.380	.675		PS	.002	.005	.013	.034	.077	.120	.172	.306
			Throw	2	3	6	9	14	17	21	28		Throw	1	2	4	6	9	12	14	19
	4' Length 8" Inlet	Horizontal	CFM	40	60	100	160	240	300	360	480	Horizontal	CFM	40	60	100	160	240	300	360	480
			PS	.005	.011	.032	.081	.183	.285	.411	.730		PS	.002	.005	.014	.035	.078	.122	.176	.312
			Throw	4	7	11	18	24	27	30	34		Throw	4	6	11	17	24	27	30	34
		Vertical	NC	<10	<10	<10	18	29	35	40	46	Vertical	NC	<10	<10	<10	<10	20	27	32	38
			PS	.005	.010	.029	.074	.165	.258	.372	.662		PS	.002	.005	.013	.033	.075	.117	.169	.300
			Throw	2	5	8	13	20	24	29	39		Throw	1	2	5	9	13	16	20	26
3/4" Slot Width	2' Length 8" Inlet	Horizontal	CFM	20	30	50	80	120	150	180	240	Horizontal	CFM	20	30	50	80	120	150	180	240
			PS	.004	.008	.023	.059	.133	.208	.299	.532		PS	.001	.002	.007	.018	.040	.062	.089	.159
			Throw	3	5	8	12	17	19	21	24		Throw	3	4	7	11	16	19	21	24
		Vertical	NC	<10	<10	<10	<10	20	26	31	38	Vertical	NC	<10	<10	<10	<10	12	17	21	29
			PS	.003	.008	.021	.054	.122	.191	.275	.490		PS	.001	.002	.006	.014	.033	.051	.073	.130
			Throw	2	3	6	9	14	17	21	27		Throw	1	1	2	4	7	8	10	13
	4' Length 10" Inlet	Horizontal	CFM	40	60	100	160	240	300	360	480	Horizontal	CFM	40	60	100	160	240	300	360	480
			PS	.004	.008	.023	.058	.130	.204	.293	.521		PS	.001	.002	.007	.017	.039	.060	.087	.154
			Throw	5	8	13	20	24	27	30	34		Throw	5	7	12	19	24	27	30	34
		Vertical	NC	<10	<10	<10	14	23	29	34	41	Vertical	NC	<10	<10	<10	<10	15	20	24	32
			PS	.003	.008	.021	.053	.120	.188	.270	.480		PS	.001	.002	.005	.014	.032	.049	.071	.127
			Throw	2	5	8	13	19	24	29	38		Throw	1	1	2	6	9	11	14	18
4' Length 8" Inlet	Horizontal	CFM	40	60	100	160	240	300	360	480	Horizontal	CFM	40	60	100	160	240	300	360	480	
		PS	.004	.008	.023	.058	.130	.204	.293	.521		PS	.001	.002	.007	.017	.039	.060	.087	.154	
		Throw	5	8	13	20	24	27	30	34		Throw	5	7	12	19	24	27	30	34	
	Vertical	NC	<10	<10	<10	14	23	29	34	41	Vertical	NC	<10	<10	<10	<10	15	20	24	32	
		PS	.003	.008	.021	.053	.120	.188	.270	.480		PS	.001	.002	.005	.014	.032	.049	.071	.127	
		Throw	2	5	8	13	19	24	29	38		Throw	1	1	2	6	9	11	14	18	

Performance Notes:

- All units have been tested in accordance with ANSI / ASHRAE 70-2006. Data in table is derived from such testing.
- Ps – Static pressure required to obtain listed cfm, units of inches water gauge (in. wg).
- NC – Calculated noise criteria using 10 dB per octave room attenuation (dimensionless).
- Throw – Non-isothermal throw, in feet, for a terminal velocity of 50 fpm. Throw are listed in one-way direction.
- Two-way throw can be determined by dividing the supply air volume equally in each direction and use the one-way throw values listed.

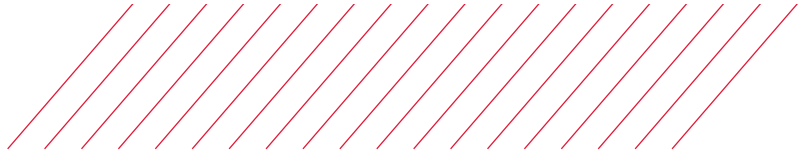
Model PHPS-6, PHPSI-6 Three Slot

		CFM/LF	25	40	60	80	100	120	160	200	
1/2" Slot Width	2' Length 8" Inlet	Horizontal	CFM	50	80	120	160	200	240	320	400
			PS	.012	.030	.068	.121	.188	.271	.483	.754
			Throw	12	15	19	21	24	26	30	34
		Vertical	NC	<10	<10	16	23	29	34	41	48
			PS	.009	.023	.052	.092	.144	.207	.368	.576
			Throw	3	7	11	15	18	21	25	27
	4' Length 8" Inlet	Horizontal	CFM	100	160	240	320	400	480	640	800
			PS	.012	.030	.067	.118	.185	.266	.473	.739
			Throw	12	19	26	30	34	37	43	48
		Vertical	NC	<10	<10	11	20	26	31	36	40
			PS	.009	.023	.051	.090	.141	.203	.361	.564
			Throw	4	10	15	21	26	30	35	39
3/4" Slot Width	2' Length 8" Inlet	Horizontal	CFM	50	80	120	160	200	240	320	400
			PS	.008	.022	.049	.087	.135	.195	.346	.541
			Throw	9	15	19	21	24	26	30	34
		Vertical	NC	<10	<10	<10	18	23	27	34	40
			PS	.006	.016	.037	.066	.103	.148	.263	.411
			Throw	2	5	9	13	16	19	25	27
	4' Length 10" Inlet	Horizontal	CFM	100	160	240	320	400	480	640	800
			PS	.008	.021	.048	.085	.133	.191	.339	.530
			Throw	15	21	26	30	34	37	43	48
		Vertical	NC	<10	<10	15	21	26	30	37	43
			PS	.006	.016	.036	.065	.101	.145	.258	.403
			Throw	7	13	19	25	27	30	35	39
1" Slot Width	2' Length 10" Inlet	Horizontal	CFM	50	80	120	160	200	240	320	400
			PS	.003	.006	.015	.026	.041	.058	.104	.162
			Throw	6	10	15	20	24	26	30	34
		Vertical	NC	<10	<10	<10	11	15	19	27	33
			PS	.002	.005	.011	.020	.031	.044	.079	.123
			Throw	1	3	4	6	7	9	12	15
	4' Length 12" Inlet	Horizontal	CFM	100	160	240	320	400	480	640	800
			PS	.002	.006	.014	.025	.040	.057	.102	.159
			Throw	7	11	16	22	27	32	42	48
		Vertical	NC	<10	<10	<10	14	18	22	30	36
			PS	.002	.005	.011	.019	.030	.044	.077	.121
			Throw	2	4	6	9	11	13	17	22
1-1/2" Slot Width	2' Length 10" Inlet	Horizontal	CFM	50	80	120	160	200	240	320	400
			PS	.003	.006	.015	.026	.041	.058	.104	.162
			Throw	6	10	15	20	24	26	30	34
		Vertical	NC	<10	<10	<10	11	15	19	27	33
			PS	.002	.005	.011	.020	.031	.044	.079	.123
			Throw	1	3	4	6	7	9	12	15
	4' Length 12" Inlet	Horizontal	CFM	100	160	240	320	400	480	640	800
			PS	.002	.006	.014	.025	.040	.057	.102	.159
			Throw	7	11	16	22	27	32	42	48
		Vertical	NC	<10	<10	<10	14	18	22	30	36
			PS	.002	.005	.011	.019	.030	.044	.077	.121
			Throw	2	4	6	9	11	13	17	22

Model PHPS-6, PHPSI-6 Four Slot

		CFM/LF	50	75	80	100	150	175	200	250	
1/2" Slot Width	2' Length 8" Inlet	Horizontal	CFM	100	150	160	200	300	350	400	500
			PS	.033	.074	.084	.131	.295	.401	.524	.819
			Throw	16	20	21	23	28	30	33	36
		Vertical	NC	<10	<10	17	23	35	39	42	48
			PS	.029	.066	.075	.117	.262	.357	.466	.729
			Throw	8	12	12	16	20	21	23	25
	4' Length 10" Inlet	Horizontal	CFM	200	300	320	400	600	700	800	1000
			PS	.032	.072	.082	.129	.289	.394	.514	.803
			Throw	23	28	29	33	40	43	46	51
		Vertical	NC	<10	<10	20	26	38	42	45	51
			PS	.029	.064	.073	.114	.257	.350	.457	.714
			Throw	11	16	17	22	28	30	32	36
3/4" Slot Width	2' Length 8" Inlet	Horizontal	CFM	100	150	160	200	300	350	400	500
			PS	.025	.057	.065	.101	.228	.311	.406	.634
			Throw	16	20	21	23	28	30	33	36
		Vertical	NC	<10	<10	<10	18	29	33	36	42
			PS	.25	.057	.065	.101	.227	.310	.404	.632
			Throw	5	10	11	13	20	21	23	25
	4' Length 10" Inlet	Horizontal	CFM	200	300	320	400	600	700	800	1000
			PS	.025	.056	.064	.099	.224	.305	.398	.622
			Throw	23	28	29	33	40	43	46	51
		Vertical	NC	<10	<10	<10	14	21	32	36	45
			PS	.025	.056	.063	.099	.223	.304	.396	.620
			Throw	13	20	20	23	28	30	32	36
1" Slot Width	2' Length 10" Inlet	Horizontal	CFM	100	150	160	200	300	350	400	500
			PS	.016	.037	.042	.066	.148	.202	.264	.412
			Throw	16	20	21	23	28	30	33	36
		Vertical	NC	<10	<10	<10	10	19	23	27	33
			PS	.012	.028	.032	.050	.112	.152	.198	.310
			Throw	16	20	21	23	28	30	33	36
	4' Length 12" Inlet	Horizontal	CFM	200	300	320	400	600	700	800	1000
			PS	.016	.036	.041	.065	.145	.198	.258	.404
			Throw	21	28	29	33	40	43	46	51
		Vertical	NC	<10	<10	<10	13	22	26	30	36
			PS	.012	.027	.031	.049	.109	.149	.194	.304
			Throw	4	6	7	9	13	15	17	22

Performance Notes:

- All units have been tested in accordance with ANSI / ASHRAE 70-2006. Data in table is derived from such testing.
- Ps – Static pressure required to obtain listed cfm, units of inches water gauge (in. wg).
- NC – Calculated noise criteria using 10 dB per octave room attenuation (dimensionless).
- Throw – Non-isothermal throw, in feet, for a terminal velocity of 50 fpm. Throw are listed in one-way direction.
- Two-way throw can be determine by dividing the supply air volume equally in each direction and use the one-way throw values listed.

Model 7305-6, 7500-6
Perforated Face With 4 Deflectors

Neck Size	Inlet Velocity	300	400	500	600	700	800	1000	
6"	CFM	60	80	100	115	135	155	195	
	Ps	.006	.012	.018	.022	.031	.043	.069	
	NC	<	<	<	<	20	24	31	
	Throw	4-W	3	4	4	5	6	7	8
		3-W	3	4	5	6	6	8	8
		2-W	4	5	5	6	7	9	9
		1-W	5	5	6	7	8	9	10
	8"	CFM	105	140	175	210	246	28	350
		Ps	.011	.021	.032	.047	.064	.084	.133
		NC	<	<	<	21	26	30	36
Throw		4-W	3	5	5	6	8	10	11
		3-W	3	5	5	6	8	11	12
		2-W	4	6	6	7	9	12	13
		1-W	5	6	7	8	10	13	14
10"		CFM	165	220	270	325	380	435	545
		Ps	.014	.025	.037	.054	.075	.098	.156
		NC	<	<	<	22	28	33	43
	Throw	4-W	4	5	6	7	8	10	12
		3-W	4	6	7	8	9	12	13
		2-W	5	6	8	8	10	14	15
		1-W	6	7	9	10	11	14	16
	12"	CFM	235	315	390	470	550	630	785
		Ps	.026	.049	.074	.108	.149	.196	.305
		NC	<	<	<	25	29	35	46
Throw		4-W	4	8	8	10	11	12	14
		3-W	5	8	9	11	13	14	15
		2-W	6	9	11	12	13	15	16
		1-W	8	9	12	13	14	16	18
14"		CFM	320	425	535	640	750	855	1070
		Ps	.033	.058	.092	.133	.182	.237	.373
		NC	<	23	29	34	39	44	50
	Throw	4-W	6	8	11	13	14	15	17
		3-W	7	9	12	14	16	17	18
		2-W	8	10	13	15	17	18	19
		1-W	9	11	14	16	18	19	20

Model 7600-6
Perforated Face With Curved Blades, Deflectors

Neck Size	Inlet Velocity	300	400	500	600	700	800	1000	1200	
6"	CFM	60	80	100	120	135	155	195	235	
	Ps	.009	.016	.025	.038	.044	.059	.095	0.139	
	NC	<	<	<	15	19	23	26	30	
	Throw	4-W	5	6	6	7	7	8	9	10
		3-W	5	6	7	7	8	9	10	10
		2-W	5	7	8	8	9	10	11	12
		1-W	9	11	12	13	14	15	17	18
	8"	CFM	105	140	175	210	245	280	350	420
		Ps	.010	.018	.028	.041	.055	.072	.113	.162
		NC	<	<	<	15	19	24	27	31
Throw		4-W	6	7	8	9	10	10	12	13
		3-W	7	8	9	10	11	11	13	14
		2-W	7	9	10	11	12	13	14	16
		1-W	12	14	16	17	19	20	22	24
10"		CFM	165	220	275	325	380	435	545	655
		Ps	.011	.020	.031	.044	.059	.078	.124	.178
		NC	<	<	<	15	20	25	29	34
	Throw	4-W	8	9	10	11	12	13	15	16
		3-W	8	10	11	12	13	14	16	18
		2-W	9	11	13	14	15	16	18	20
		1-W	15	18	20	21	23	25	28	30
	12"	CFM	235	315	395	470	550	630	785	940
		Ps	.012	.023	.036	.052	.070	.093	.144	.205
		NC	<	<	<	15	22	27	31	36
Throw		4-W	9	11	12	13	15	16	17	19
		3-W	10	12	14	15	16	17	19	21
		2-W	11	14	15	17	18	19	21	23
		1-W	18	21	24	26	28	30	33	36
14"		CFM	320	430	535	640	750	855	1070	1285
		Ps	.011	.021	.032	.046	.063	.082	.129	.186
		NC	<	<	<	15	16	24	29	33
	Throw	4-W	12	15	16	18	19	21	23	25
		3-W	13	16	18	20	21	23	26	28
		2-W	14	18	20	22	24	26	29	31
		1-W	24	28	31	34	37	40	44	49

Model 7300-6
Perforated Face With Target Disc

Neck Size	Inlet Velocity	200	300	400	500	600	700	800	900	1000
6"	CFM	40	60	80	100	115	135	155	175	196
	Ps	.002	.003	.006	.011	.013	.019	.026	.028	.043
	NC	<	<	<	<	22	26	30	35	38
	Throw	1	1	4	4	5	6	7	8	10
8"	CFM	70	105	140	175	210	245	280	315	350
	Ps	.004	.007	.016	.021	.032	.043	.056	.071	.088
	NC	<	<	<	<	20	23	26	30	34
	Throw	2	3	5	5	6	8	10	11	12
10"	CFM	110	160	215	270	325	380	435	490	545
	Ps	.006	.012	.023	.036	.053	.081	.095	.121	.160
	NC	<	<	<	<	20	23	26	30	34
	Throw	3	4	5	6	7	8	10	12	14
12"	CFM	155	235	315	390	470	550	630	705	785
	Ps	.007	.015	.029	.043	.064	.088	.115	.144	.178
	NC	<	<	<	<	20	24	27	30	34
	Throw	4	5	7	9	11	13	14	18	21
14"	CFM	210	320	425	535	640	750	855	960	1070
	Ps	.008	.016	.029	.047	.069	.094	.122	.160	.191
	NC	<	<	<	<	20	24	28	32	36
	Throw	6	9	11	13	16	18	23	27	32
15"	CFM	245	370	490	610	735	860	980	1105	1225
	Ps	.013	.028	.050	.077	.113	.155	.200	.255	.313
	NC	<	<	<	<	23	28	33	38	43
	Throw	9	11	13	16	18	23	27	32	33

Model 7300R-6, 7500R-6, 7600R-6, 7550R-6
Perforated Face Return Units

Neck Size	Inlet Velocity	300	400	500	600	700	800	900	1000
6"	Ps	-.01	-.02	-.03	-.04	-.05	-.06	-.08	-.10
	CFM	60	80	100	115	135	155	175	195
8"	CFM	105	140	175	210	245	280	315	350
10"	CFM	165	220	270	325	380	435	490	545
12"	CFM	235	315	390	470	550	630	705	785
14"	CFM	320	425	535	640	750	855	930	1070
15"	CFM	369	492	615	738	861	984	1107	1203

Model SPRTB, SPR20F, SPRFB
Perforated Face Return Units

Neck Size	Inlet Velocity	200	300	400	500	600	700	800
12x12	CFM	170	250	335	420	505	590	670
	NC	<	<	<	<	20	25	30
24x12	CFM	350	525	700	875	1050	1225	1400
	NC	<	<	<	<	20	25	30
24x24	CFM	735	1100	1470	1835	2200	2570	2935
	NC	<	<	<	<	20	28	33
48x12	CFM	735	1100	1470	1835	2200	2570	2935
	NC	<	<	<	<	20	28	33
48x24	CFM	1500	2250	3000	3750	4500	5250	6000
	NC	<	<	<	<	20	28	33

Performance Notes:

- All units have been tested in accordance with ANSI / ASHRAE 70-2006. Data in table is derived from such testing.
- Ps – Static pressure required to obtain listed cfm, units of inches water gauge (in. wg.).
- NC – Calculated noise criteria using 10 dB per octave room attenuation (dimensionless).
- Throw – Non-isothermal throw, in feet, for a terminal velocity of 50 fpm.
- Inlet Velocity = fpm (feet per minute).



Model 4900 Square Necks (S4) 4 Way Square Pattern

Neck Size Area Ak	Ps Pt	Neck Velocity					
		200	300	400	500	600	700
		.006	.013	.022	.035	.050	.068
6" X 6" A=.25 Ak=.145	Total CFM	52	76	100	124	152	176
	CFM/Side	13	19	25	31	38	44
	Throw NC	2-4	4-8	7-11	9-13	11-16	13-17
9" X 9" A=.563 Ak=.325	Total CFM	112	168	224	280	336	392
	CFM/Side	28	42	56	70	84	98
	Throw NC	<15	<15	15	21	26	31
12" X 12" A=1.000 Ak=.578	Total CFM	200	300	400	500	600	700
	CFM/Side	50	75	100	125	150	175
	Throw NC	3-7	6-10	9-14	11-16	13-18	15-20
15" X 15" A=1.563 Ak=.903	Total CFM	312	468	624	780	936	1092
	CFM/Side	78	117	156	195	234	273
	Throw NC	4-8	7-12	10-15	12-18	15-20	17-22
18" X 18" A=2.25 Ak=1.301	Total CFM	452	676	900	1124	1352	1576
	CFM/Side	113	169	225	281	338	394
	Throw NC	5-10	8-14	11-17	14-20	16-22	18-23
21" X 21" A=3.063 Ak=1.77	Total CFM	612	920	1224	1532	1836	2144
	CFM/Side	153	230	306	383	459	536
	Throw NC	6-12	9-16	12-19	15-21	17-23	19-25
24" X 24" A=4.000 Ak=2.312	Total CFM	800	1200	1600	2000	2400	2800
	CFM/Side	200	300	400	500	600	700
	Throw NC	7-14	10-17	13-20	16-23	18-25	21-27



(S3) 3 Way Square Pattern

Neck Size Area Ak	Ps Pt	Neck Velocity					
		200	300	400	500	600	700
		.006	.013	.022	.035	.050	.068
6" X 6" A=.25 Ak=.145	Total CFM	51	75	99	123	153	177
	CFM/Side	17	25	33	41	51	59
	Throw NC	2-4	4-8	7-11	9-13	11-16	13-17
9" X 9" A=.563 Ak=.304	Total CFM	111	168	225	279	336	393
	CFM/Side	37	56	75	93	112	131
	Throw NC	<15	<15	15	21	26	31
12" X 12" A=1.000 Ak=.541	Total CFM	201	300	399	501	600	699
	CFM/Side	67	100	133	167	200	233
	Throw NC	3-7	6-10	9-14	11-16	13-18	15-20
15" X 15" A=1.563 Ak=.845	Total CFM	312	468	624	780	936	1092
	CFM/Side	104	156	208	260	312	364
	Throw NC	4-8	7-12	10-15	12-18	15-20	17-22
18" X 18" A=2.25 Ak=1.216	Total CFM	453	675	900	1125	1353	1575
	CFM/Side	151	225	300	375	451	525
	Throw NC	5-10	8-14	11-17	14-20	16-22	18-23
21" X 21" A=3.063 Ak=1.655	Total CFM	612	921	1224	1533	1836	2145
	CFM/Side	204	307	408	511	612	715
	Throw NC	6-12	9-16	12-19	15-21	17-23	19-25
24" X 24" A=4.000 Ak=2.162	Total CFM	801	1200	1599	2001	2400	2799
	CFM/Side	267	400	533	667	800	933
	Throw NC	7-14	10-17	13-20	16-23	18-25	21-27

(S2) 2 Way Opposite / (SC) 2 Way Adjacent Square Pattern

Neck Size Area Ak	Ps Pt	Neck Velocity					
		200	300	400	500	600	700
		.006	.013	.022	.035	.050	.068
6" X 6" A=.25 Ak=.132	Total CFM	52	76	100	124	152	176
	CFM/Side	26	38	50	62	76	88
	Throw NC	2-5	5-9	8-12	10-14	12-17	14-18
9" X 9" A=.563 Ak=.298	Total CFM	112	168	224	280	336	392
	CFM/Side	56	84	112	140	168	196
	Throw NC	3-7	6-11	9-14	12-17	14-19	16-20
12" X 12" A=1.000 Ak=.529	Total CFM	200	300	400	500	600	700
	CFM/Side	100	150	200	250	300	350
	Throw NC	5-10	8-13	11-16	13-19	15-21	17-23
15" X 15" A=1.563 Ak=.827	Total CFM	312	468	624	780	936	1092
	CFM/Side	156	234	312	390	468	546
	Throw NC	6-12	9-16	12-19	15-21	17-24	19-25
18" X 18" A=2.25 Ak=1.190	Total CFM	452	676	900	1124	1352	1576
	CFM/Side	226	338	450	562	676	788
	Throw NC	7-14	10-18	14-21	17-24	19-26	21-28
21" X 21" A=3.063 Ak=1.620	Total CFM	612	920	1224	1532	1836	2144
	CFM/Side	306	460	612	766	918	1072
	Throw NC	8-17	12-20	15-23	18-26	21-28	23-30
24" X 24" A=4.000 Ak=2.116	Total CFM	800	1200	1600	2000	2400	2800
	CFM/Side	400	600	800	1000	1200	1400
	Throw NC	9-18	13-22	16-25	19-28	22-30	24-30



(S1) 1 Way Square Pattern

Neck Size Area Ak	Ps Pt	Neck Velocity					
		200	300	400	500	600	700
		.006	.013	.022	.035	.050	.068
6" X 6" A=.25 Ak=.122	Total CFM	50	75	100	125	150	175
	Throw NC	3-7	6-10	9-14	11-16	13-18	15-20
	CFM/Side	<15	<15	<15	15	20	25
9" X 9" A=.563 Ak=.275	Total CFM	113	169	225	281	338	394
	Throw NC	5-10	8-14	11-17	14-20	16-22	18-23
	CFM/Side	<15	<15	15	21	26	31
12" X 12" A=1.000 Ak=.541	Total CFM	201	300	399	501	600	699
	CFM/Side	67	100	133	167	200	233
	Throw NC	3-7	6-10	9-14	11-16	13-18	15-20
15" X 15" A=1.563 Ak=.845	Total CFM	312	468	624	780	936	1092
	CFM/Side	104	156	208	260	312	364
	Throw NC	4-8	7-12	10-15	12-18	15-20	17-22
18" X 18" A=2.25 Ak=1.216	Total CFM	453	675	900	1125	1353	1575
	CFM/Side	151	225	300	375	451	525
	Throw NC	5-10	8-14	11-17	14-20	16-22	18-23
21" X 21" A=3.063 Ak=1.655	Total CFM	612	921	1224	1533	1836	2145
	CFM/Side	204	307	408	511	612	715
	Throw NC	6-12	9-16	12-19	15-21	17-23	19-25
24" X 24" A=4.000 Ak=2.162	Total CFM	801	1200	1599	2001	2400	2799
	CFM/Side	267	400	533	667	800	933
	Throw NC	7-14	10-17	13-20	16-23	18-25	21-27

Performance for rectangular neck units go to usaire.com

Performance Notes:

1. Ps – Static Pressure = Pt-Pv (Inches of water column).
2. Pt – Total Pressure (Inches of water column).
3. Throw – Horizontal distances in feet to the terminal velocities of 150-50 fpm with ambient supply air temperature
4. fpm – Velocity of air stream in feet per minute

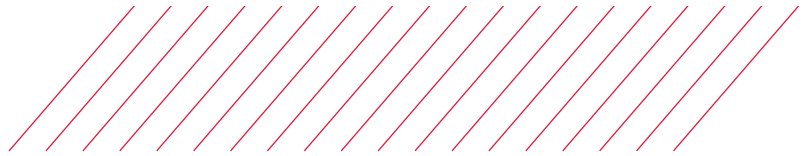

Index

Model	Page
101M	4
102M	4
103M	5
104M	5
201M	6
202M	6
203M	7
204M	7
900	14
900S	14
900D	14
900DS	14
1300	8
1320	8
1340	9
1400	9
1410AD	10
1410F	10
1410FTB	49
1420F	50
1410FTBI	49
1500	11
1510D	11
1510DX	12
1510X	12
1520M	12
1530	13
1530M	13
2000F	45
2000FD	45
3100	43
3100S	43
3100A	43
3100SA	43
4000SVM	17
4004P	44
4004SP	44
4700-6	67
4700D-6	67
4706-6	68
4706D-6	68
4750-6	69
4750D-6	69
4756-6	70
4756D-6	70
4800-6	71
4800D-6	71
4806-6	72
4806D-6	72
4900	40
4900D	40
4900-6	74
5200	15
5200-D	15
5200-2C	16
5200D-2C	16
5200-6	59
5200-6D	59
5200-6 2C	60
5200-6D 2C	60
5500 DAF-CC5	39
5500 DAF-CC5-6	76
5500SI-6	75

Model	Page
5906-6	73
5906-3-6	73
5956-6	74
6600	46
7300-6	61
7300R-6	61
7305-6	62
7500-6	64
7500R-6	64
7550R-6	65
7600-6	66
7600R-6	66
9000	39
9000-6	75
BDS	78
CC5	37
CC520F	58
CC5CO	58
CC5D	37
CC5DTB	56
CC5F	38
CC5FTB	57
CC5FTBI	57
CC5TB	56
D3	43
DG	41
DGDF	41
DGSF	42
FGB-R6	79
H4002	30
H4002D	31
H4002M	32
H4004	33
H4004D	34
L	21
LD	23
LM	25
LMH	27
LS3	22
LS3D	24
LS3M	26
LS4M	26
LS4	22
LS4D	24
LT	21
LTC	22
LTC3	22
LTC3D	24
LTD	23
LTM	25
LTMH	27
OBD	80
OBDA	80
PF	79
PHPR	47
PHPRI	48
PHPS	47
PHPSI	48
RH	28
RH20F	54
RHD	28
RHE	35

Model	Page
RHED	35
RHEF	36
RHEFTB	55
RHEFTBI	55
RHETB	54
RHF	29
RHFTB	53
RHFTBI	53
RHTB	52
RSD	78
SD3	43
SNAP 58	77
SNAP 59	77
SNAP 59-2	77
SPRFTB	63
SPRTB	62
SPR20F	63
SRH	17
SRHF	18
SRH-6	50
SRHF-6	51
SRHFI-6	51
SRH20F	52
STBP	78
STBPF	79
TBP	78
TBPF	79
TR	81
TRD	81
V	18
VD	19
VH	20
VHD	20
VM	19
V4002	30
V4002D	31
V4002M	32
V4004	33
V4004D	34
PBD-20 RS	85
PBD-20	85
XABD-2	86
XAJ-4-GL	87
XAD-4-45-GL	87
FD-A	88
FD-A-SL	88
FD-B	89
FD-C	89
FD-A-S	90
FD-B-S	90
FD-C-S	91
FDD-A	92
FDD-A-SL	92
FDD-B	93
FDD-C	93
FDD-A-S	94
FDR-B-S	94
FDD-C-S	95
CD-RD-A	96
CD-S/R-A	96
CR-S/R-HC	97

USAIRE® reserves the right to make changes to product descriptions, configurations, available sizes, packaging and pricing without notice. Please visit www.usaire.com for additional information.



**METAL
INDUSTRIES, INC.**

BUILT ON THE PAST, FOCUSED ON THE FUTURE

Metal Industries, Inc. offers a complete line of quality air distribution products and air terminal units. Our company is dedicated to providing the highest level of service in the HVAC industry. Since our inception in 1947, Metal Industries, Inc. has grown to become a leading worldwide supplier of commercial air distribution products. Metal Industries, Inc. products are sold under several brands throughout the United States and around the world.

The Metal Industries, Inc. product offering includes grilles, registers, diffusers, air terminal units, louvers, penthouses, equipment screens, sun shades, dampers and life-safety products. Metal Industries, Inc. has a broad network of representatives knowledgeable in all phases of HVAC design and selection; our experienced team, along with the technical expertise of our representative network can provide custom solutions for even the most complex air distribution challenges and energy saving strategies.

Metal Industries, Inc. is a privately owned company located in Clearwater, Florida.

www.usaire.com • 800-998-9929

Metal Industries, Inc. • 1985 Carroll Street • Clearwater, Florida 33765

Registered Trademarks: Roto-Louver®, Mod-Flo®, METALAIR®

Trademarks: Formations™, Phenomentor™

Patents: U.S. D 311,577; U.S. 4,912,973; U.S. 5,236,393; U.S. 6,386,970; U.S. 6,648,752;
Other Patents Pending