



Limited One Year Warranty

T&S warrants to the original purchaser (other than for purposes of resale) that such product is free from defects in material and workmanship for a period of one (1) year from the date of purchase. During this one-year warranty period, if the product is found to be defective, T&S shall, at its options, repair and/or replace it. To obtain warranty service, products must be returned to...

*T&S Brass and Bronze Works, Inc.
Attn: Warranty Repair Department
2 Saddleback Cove
Travelers Rest, SC 29690*

Shipping, freight, insurance, and other transportation charges of the product to T&S and the return of repaired or replaced product to the purchaser are the responsibility of the purchaser. Repair and/or replacement shall be made within a reasonable time after receipt by T&S of the returned product. This warranty does not cover items which have received secondary finishing or have been altered or modified after purchase, or for defects caused by physical abuse or misuse of the product, or shipment of the products.

Any express warranty not provided herein, and any remedy for Breach of Contract which might arise, is hereby excluded and disclaimed. Any implied warranties of merchantability or fitness for a particular purpose are limited to one year in duration. Under no circumstances shall T&S be liable for loss of use or any special consequential costs, expenses or damages.

Some states do not allow limitations on how long an implied warranty lasts or the exclusion or limitation of incidental or consequential damages, so the above limitations or exclusions may not apply to you. Specific rights under this warranty and other rights vary from state to state.

P/N: 098-016361-45 Rev.6
Date: 04-22-14
Drawn: TEH
Checked: GEF 05-07-14
Approved: JHB 05-07-14

Installation and Maintenance Instructions



EC-3100 Series ChekPoint ELECTRONIC FAUCET DECK-MOUNT & WALL-MOUNT GOOSENECK, SPOUT & 4" CENTERSET SENSOR OPERATED

Exploded View

EC-3100

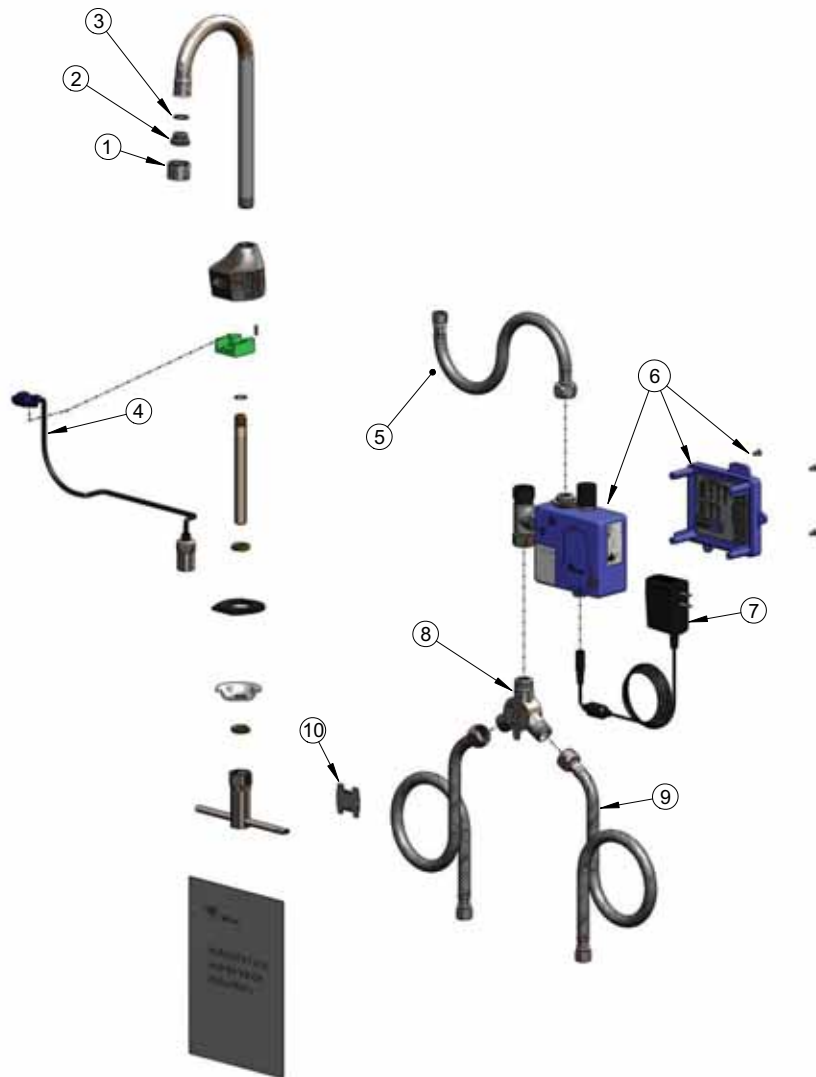

Exploded View

EC-3101

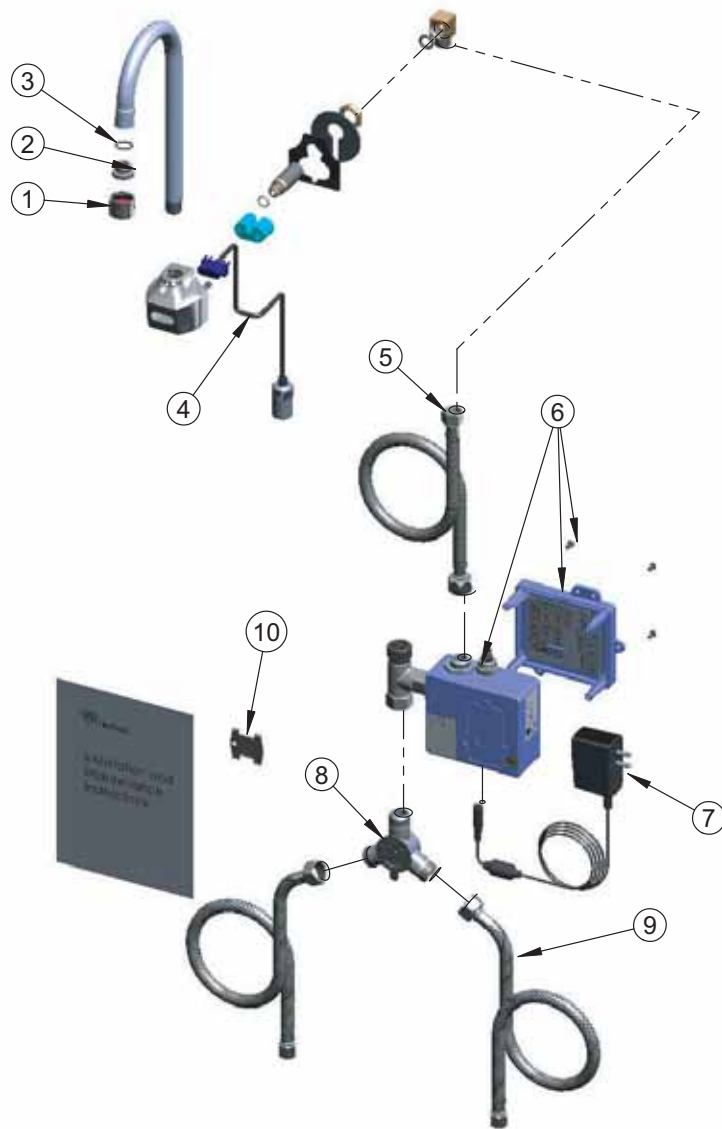

Exploded View

EC-3102

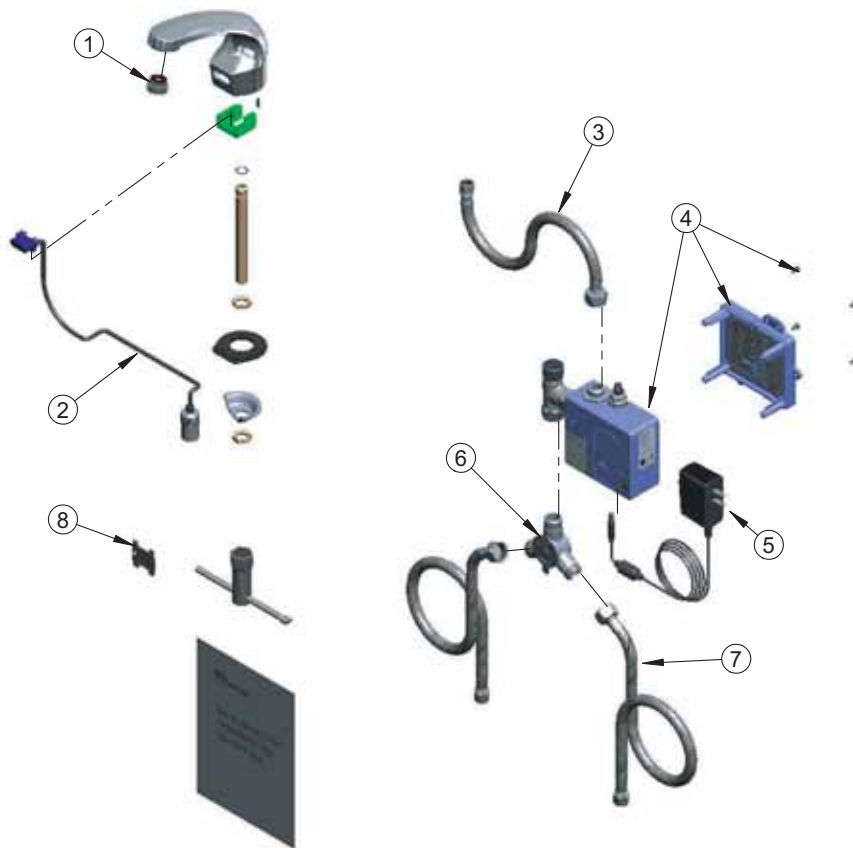

Exploded View

EC-3103

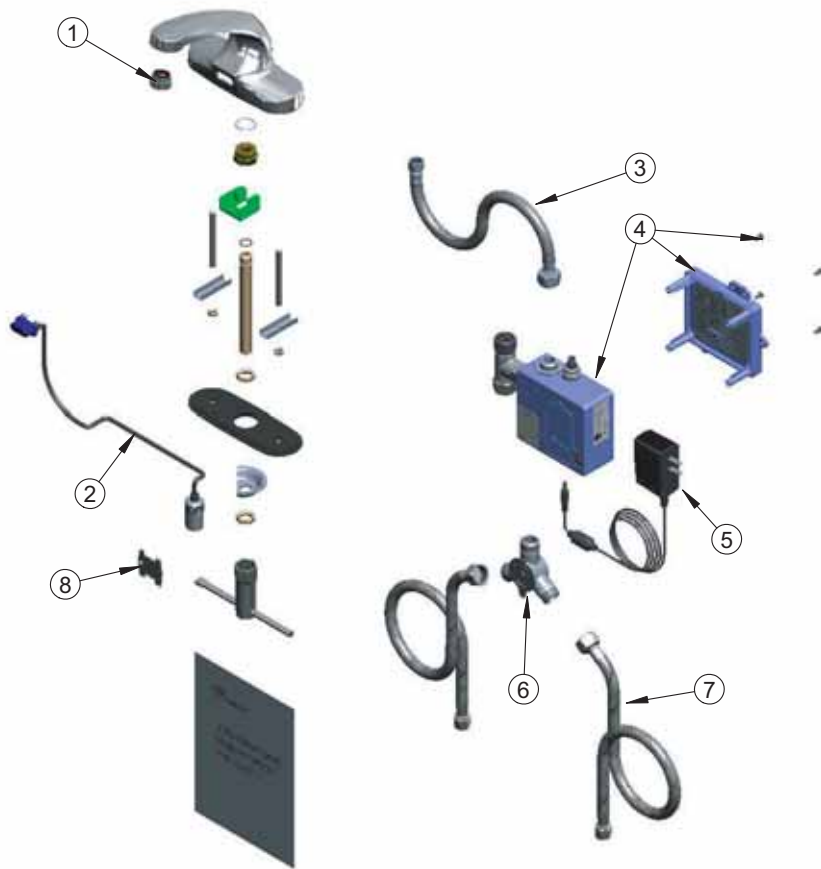

Exploded View

EC-3106

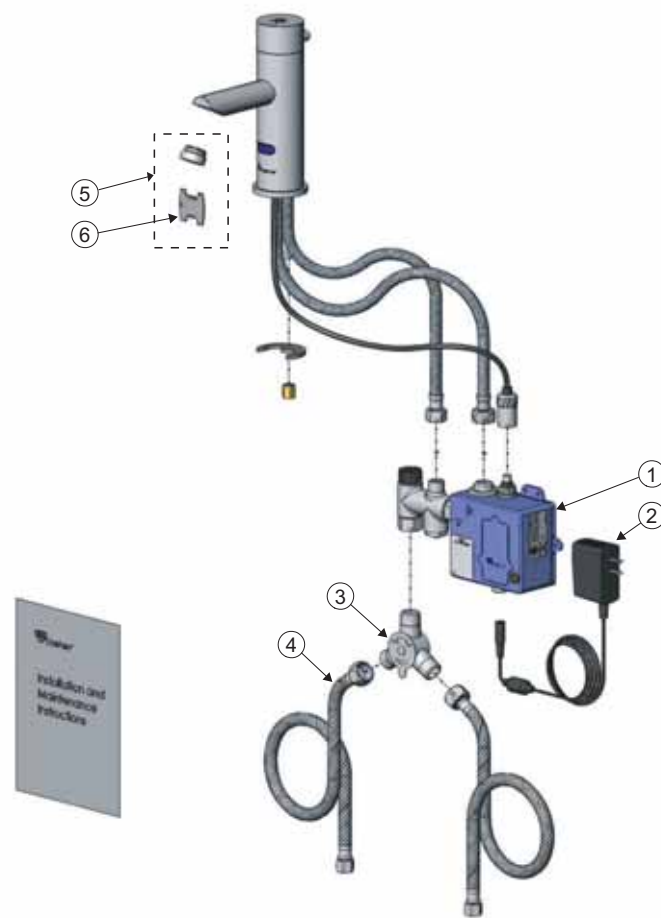

Part Number Guide

EC-3100 & EC-3101 Electronic Faucets

1	Aerator, Vandal Resistant	B-0199-06
2	Adapter for Non-Splash Aerator	044A
3	O-Ring	006575-45
4	Angled Sensor w/ Cable	017195-45
5	Inlet Hose for use with EC-3100 1/2" NPSM-F x 1/4" NPSM-F x 18" Long	016297-45
5	Inlet Hose for use with EC-3101 1/2" NPSM-F x 3/8" NPSM-F x 30" Long	016325-45
6	Electronic Module	016647-45
7	A/C Transformer	5EF-0002
8	Manual Mixing Valve	5EF-0006
9	Supply Hose, 9/16-24 UN Female x 1/2" NPSM	5EF-0005
10	Vandal Resistant Key	Q015425-45

EC-3102 & EC-3103 Electronic Faucets

1	Aerator, Vandal Resistant, 2.2 GPM	016355-45
2	Angled Sensor w/ Cable	017195-45
3	Inlet Hose, Faucet, 1/2" NPSM-F x 1/4" NPSM-F	016297-45
4	Electronic Module	016647-45
5	A/C Transformer	5EF-0002
6	Manual Mixing Valve	5EF-0006
7	Supply Hose, 9/16-24 UN Female x 1/2" NPSM	5EF-0005
8	Vandal Resistant Key	Q015425-45

EC-3106 Electronic Faucet

1	ChekPoint Module (Blue) with Bypass Tee	017493-45
2	A/C Transformer	5EF-0002
3	Manual Mixing Valve	5EF-0006
4	Supply Hose, 9/16-24 UN Female x 1/2" NPSM	5EF-0005
5	VR Aerator with Key	B-0199-09
6	Vandal Resistant Key	Q015425-45

General Instructions

Important:

- ALL ELECTRICAL WIRING IS TO BE INSTALLED IN ACCORDANCE WITH NATIONAL/LOCAL CODES AND REGULATIONS.
- ALL PLUMBING IS TO BE INSTALLED IN ACCORDANCE WITH APPLICABLE CODES AND REGULATIONS.
- USE APPROPRIATE PRECAUTIONS WHILE CONNECTING TRANSFORMER TO 120 VAC POWER SOURCE.
- DO NOT PLUG TRANSFORMER INTO POWER SOURCE (RECEPTACLE) UNTIL ALL WIRING IS COMPLETED.
- FLUSH ALL WATER LINES UNTIL WATER IS CLEAR BEFORE CONNECTING FAUCET TO SUPPLY STOPS.

Tools Required For Installation of Faucets

- 8" (200mm) adjustable wrench
- 1/8" hex key wrench
- Basin wrench
- Slotted screwdriver, 3/16"
- Phillips head screwdriver, #1
- Pliers

Prior to Installation:

Prior to installing the T&S ChekPoint Series Faucet, install the items listed on next column. Also, refer to Figure 1.

- Provide electrical receptacle within approximately 6' from sink for plug-in transformer — 120 VAC, 2 amp service for each plug-in transformer used.
- Scrub or wash-up sink
- Drain line
- Hot and cold water supply lines

Mixing Valve

When installing the faucet with the mixing valve the Installation Instructions MUST be followed.

Figure 1

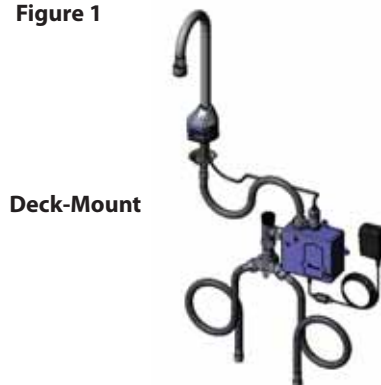

General Instructions

Installation of ChekPoint Faucets

The T&S ChekPoint Sensor Operated Faucet is a pre-tempered faucet. A mixing valve (supplied) must be used in conjunction with the faucet. Water temperature can be controlled by adjusting the mixing valve.

Install Faucet Assembly (Figures 2A, 2B, 2C and 2D)

TO MOUNT ON A SURFACE UP TO 1" (25mm) THICK

Insert faucet cable and spout shank through base gasket and then through the mounting hole of scrub or wash-up sink. Secure using lockwasher and nut supplied.

Note: T&S Brass does NOT supply hardware necessary for mounting the faucet on surfaces thicker than 1" (25 mm) thick.



Figure 2A
Wall-Mount
(Front View)

(Back View)

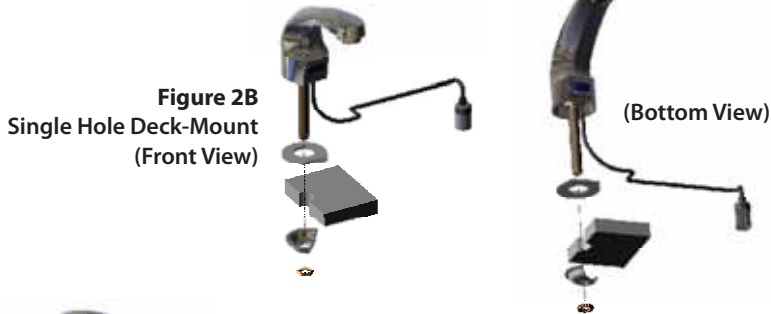

Figure 2B
Single Hole Deck-Mount
(Front View)

(Bottom View)

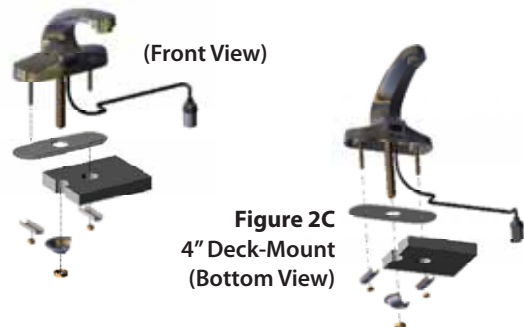

Figure 2C
4" Deck-Mount
(Bottom View)



Figure 2D
EC-3106

General Instructions

OPTIONAL ANTI-ROTATION FEATURE

Wall-Mount Model: EC-3101

(Figure 2D)

Note: The anti-rotation feature uses a set screw to anchor the faucet in the vertical position and is intended for use ONLY on stainless steel sinks.

Use the mounting hole diagram or faucet base gasket as a template by placing it in position over the faucet mounting hole. Mark the stainless steel mounting surface at the center of the small notch at the bottom of the base gasket. Drill a 9/32" (7.14 mm) diameter hole through the stainless steel mounting surface. Extend the 1/4-20 set screw installed in the back of the faucet body by unscrewing it (counterclockwise) with a 1/8" hex key wrench. Unscrew it far enough that it protrudes past the base gasket and into the 9/32" drilled hole. Assemble the washer and nut to secure the faucet in place.

EC-3101 MOUNTING HOLE DIAGRAM

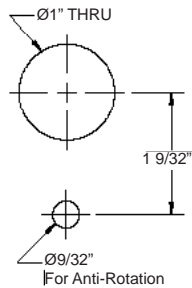
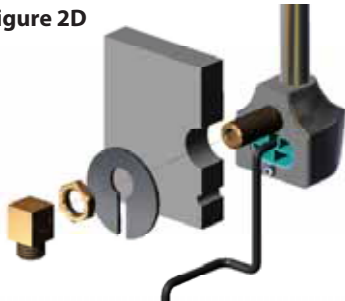

Figure 2D



OPTIONAL ANTI-ROTATION FEATURE

Deck-Mount Models: EC-3100 & EC-3102

(Figure 2E)

Note: The anti-rotation feature uses a pin to anchor the faucet in position and is intended for use ONLY on stainless steel sinks.

Use the mounting hole diagram or the faucet base gasket as a template by placing it in position over the faucet mounting hole. Mark the stainless steel mounting surface at the center of the small hole at the bottom of the base gasket. Drill a 5/32" (4 mm) diameter hole through the stainless steel mounting surface. Install the faucet aligning the pin with the small hole. Assemble the washer and nut to secure the faucet in place.

Note: The pin can be removed with pliers if not needed.

EC-3100 & EC-3102 MOUNTING HOLE DIAGRAM

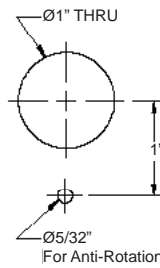
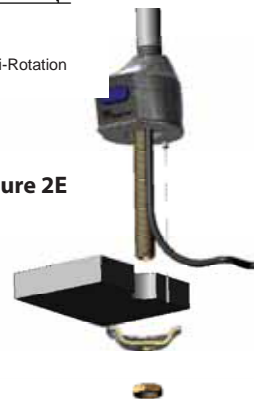

Figure 2E



General Instructions

Install Mixing Valve Assembly (Figure 3) (If supplied separately)

Install mixing valve into fitting on control module as shown in Figure 3. Tighten fitting snugly **BUT DO NOT OVERTIGHTEN**. No thread sealant is necessary.

Important: Orient mixing valve as shown in Figure 3.

Mount Control Module to Wall

Install the control module in an appropriate location. When installed all cables and hoses should have some slack. Mount control module to wall using mounting screws and plastic anchors (not included). It is important to have the control box mounted securely before any further connections are made.

FOR HOT AND COLD WATER SUPPLY APPLICATIONS

Supply stops must be furnished by installer or purchased from T&S. Flush supply lines of any debris. Tighten compression fittings securely on supply lines.

Sensor Cable and Supply Line Connections

(Figures 4, 4a and 4b)

Route the sensor cable from the spout to the top of the control module. Align the (2) white arrows (one on the male side and one on the female side) and plug the mating connectors together. Drop the chrome sleeve down over the sensor plug and screw to tighten (fig. 4a ①). Secure the supply line from the spout to the fitting on top of the controller (do not overtighten). (Fig. 4a ②) For the EC-3106, also secure the second supply line to the manual by-pass on the manifold next to the controller (Fig. 4b ③). Tighten the compression fitting securely on the supply lines but do not over tighten.

Figure 3



Figure 4



Figure 4a

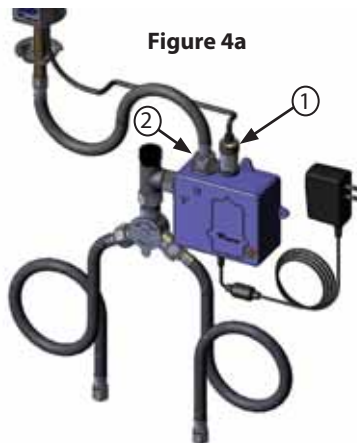
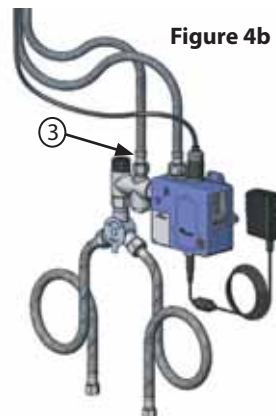

Figure 4b



General Instructions

TRANSFORMER OPTION (Figure 5)

Important: DO NOT plug Transformer into receptacle until all wiring has been completed.

This type of Transformer is designed to be plugged into a 120 VAC wall receptacle. The Transformer is supplied with a 6 foot Cable. Remove the rubber plug from the transformer connector on the control module. Plug the transformer cable into the transformer connector.

Figure 5



plug-in transformer

BATTERY OPTION

Note: Should you choose to run your sensor faucet on battery power, it will require (4) AA alkaline batteries.

1. If the AC adapter is plugged in, unplug it from its power source and the control module.
2. With the help of a phillips head screwdriver, remove the battery cover's three (3) fasteners and pull cover away from the control box.
3. Replace old batteries if needed.
4. Install the new AA batteries, making sure that the + and - ends are facing the correct direction. Return the battery cover to its spot and tighten fasteners.
5. Re-set the sensor range if needed (see sensor range setup).

Note: For the Hydro Generator (EC-HYDROGEN) power option, refer to the instruction manual in the EC-HYDROGEN kit ordered separately. For hard wiring and hard wire ganging (EC-HARDWIRE) and easy-wire (EC-EASYWIRE) ganging power options, refer to the instruction manual in each respective kit when ordered separately.

SENSOR RANGE SETUP

1. AF-serial sensor range can only be set by using the on/off button situated on the bottom right corner of the control box. Do not attempt to open control box.
2. Push and hold the on/off button for 5-7 seconds. Water flow will stop and the red LED light inside the electronic eye will blink on. Release the on/off button. The LED should turn itself off, signaling that the faucet is ready for setup.
3. Place and hold your hand at the desired sensor distance. The LED will turn "ON".
4. Use the other hand to press the on/off button. The LED will flash 5 times to save the new sensor range setting.
5. The default sensor range is 5-1/2" (14cm). Sensing distance is adjustable from 3/4" (2cm) to 5-1/2" (14cm).



General Instructions

OPERATION

1. Place hands under spout. Water will flow for as long as the user's hands remain within sensor range and will shut off after 15 seconds (time adjustable).
2. Keep electronic eye cover clean.
3. Red flashing in the electronic eye indication low batteries.
(Replacement batteries: Alkaline AA.)
4. Solid red light in the electronic eye and no water flow indicated batteries are dead.
5. When used in conjunction with the optional AC adapter, the faucet will automatically switch to AC power and conserve its battery power.

Fresh alkaline batteries should last 450,000 on/off cycles.

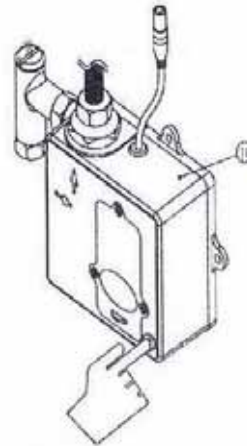

Running Time Range: 15 seconds - 20 minutes (6 presets selectable)
Response Time: 0.3 seconds
Sensing Range: 3/4" to 5-1/2" (2-14 cm) from sensor
Power Source: AC and/or DC
Low Battery Indicator: Red LED on

(See next page for EC-3106 Manual/Auto Operation.)

CARE AND CLEANING OF CHROME AND SPECIAL FINISHES

DO NOT use abrasive or chemical cleaners (including chlorine bleach) to clean faucets as they may dull the luster and attack the chrome or special decorative finishes. Use ONLY soap and water, then wipe dry with clean cloth or towel. While cleaning the bathroom tile, the faucet should be protected from any splattering of cleaner. Acids and cleaning fluids will discolor or remove chrome plating. Do not use abrasive or chemical cleaners on the sensor lens as this will damage it and affect operation.

General Instructions

EC-3106 (MANUAL/AUTO OPERATION)

The EC-3106 model has the ability to be switched from the sensor mode to a manual mode. The manual mode can be used if a constant flow of water is needed for an extended period of time (e.g. the unit loses power, etc.). To switch from sensor to manual mode, press the red button behind the unit toward the top and turn counterclockwise 180° until the red button clicks. The window on top of the unit will be changed from 'auto' to 'OFF'. The unit is now in manual mode and will operate as a manual faucet delivering water according to the temperature set on the manual mixing valve. To activate water flow, turn the top of the unit counterclockwise 90°, clockwise 90° to shut it off. To return to sensor mode, press the red button and rotate the top of the unit clockwise until the red button is in the back of the faucet and "clicks" into position. "Auto" will show in the window to indicate the unit is now in the sensor mode.

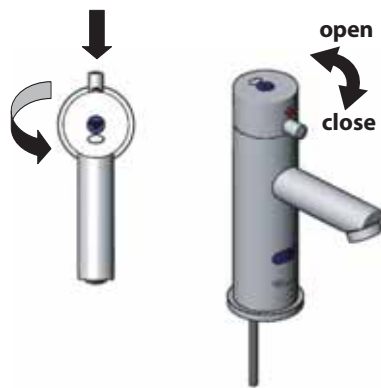

Sensor Module ByPass Operation (EC-3106 only)

If the sensor faucet is in need of repair and must be serviced and the blue control module removed, the by-pass valve must be closed with a flat head screwdriver by accessing the shut-off screw on the bottom-side of the manifold (fig. 6 ①). The controller can then be removed for servicing and the faucet can continue to be used by changing it to the manual mode as described above.

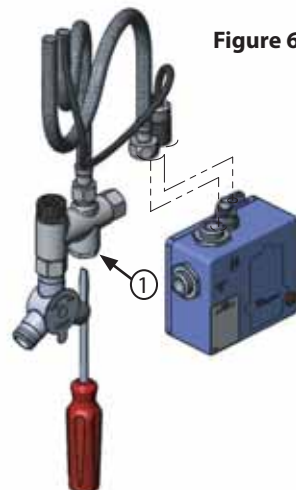

Figure 6

General Instructions

FEATURES

➤AUTO-ADJUSTMENT SCAN PERIOD

- Two scan periods of 0.4 seconds or 0.7 seconds are automatically adjusted. The scan period at 0.4 seconds occurs while the faucet is at standby. The scan period will change to 0.7 seconds when the faucet detects an object in the front of the sensor.

➤WATER FLOW CONTROL ADJUSTMENTS

- The ChekPoint controller offers a selection of pre-set flow control adjustments. These selections are made by configuring a bank of six switches, SW(1) to SW(6), according to the tables below. The flow control switches are located inside the ChekPoint control module in a black box next to the battery compartment. To access the switches, remove the (4) screws and back cover of the control module.

➤AUTO TIME-OUT ADJUSTMENT (SWITCHES 1-3)

- The ChekPoint controller provides six periods to select from for shutting off the water when the object is left in front of the electronic eye. The time periods to select from are: 15 seconds, 30 seconds, 45 seconds, 60 seconds, 3 minutes and 20 minutes. The default setting is 15 seconds.

Note: The chart below indicates the switch positions required for each auto time-out mode.

Auto Time Out Selection			
PERIOD	SW(1)	SW(2)	SW(3)
15 seconds	OFF	OFF	OFF
30 seconds	OFF	OFF	ON
45 seconds	OFF	ON	OFF
60 seconds	OFF	ON	ON
3 minutes	ON	OFF	OFF
20 minutes	ON	OFF	ON

Water Shut Off Delay Selection		
PERIOD	SW(5)	SW(6)
1 seconds	OFF	OFF
10 seconds	OFF	ON
15 seconds	ON	OFF
30 seconds	ON	ON

Auto Flush Mode SW (4)
ON - (Enable)
OFF - (Disable)

➤WATER SHUT-OFF DELAY ADJUSTMENT (SWITCHES 5 & 6)

- The ChekPoint controller provides four periods to select from for shutting off the water when the object is removed from in front of the electronic eye. The time periods to select from are: 1 second, 10 seconds, 15 seconds, and 30 second. The default setting is 1 second.

➤AUTO-FLUSH (SWITCH 4)

- The ChekPoint controller offers the option to select the Auto Flush mode in switch 4 position. When enabled, the controller will flush the ChekPoint faucet every 12 hours for 25-30 seconds when the faucet is not used. Default setting from the factory is in the "off" position.

General Instructions

➤ LOW BATTERY DETECTION

- A red flashing light in the electronic eye indicates low batteries.
- A solid red light in the electronic eye and no water flow indicates the batteries are dead.
- The user should change new batteries immediately.

➤ POWER SAVING

- If the electronic eye (sensor) has not detected object motion within 30 minutes, the controller will enter its lowest scan period of 1.4 seconds
- When object motion is detected, the controller will change the scan period from 0.4 seconds to 0.7 seconds and change back to 0.4 seconds when the object removed.

➤ ANTI-INTERFERENCE SYSTEM

- Sunlight or other types of lighting may interfere with the distance sensing range. In this case, the controller will compensate the sensing distance to a safe range temporarily. The controller will adjust the distance to the normal range when no interference is detected.

General Instructions

Q&A

Q: Can I operate the faucet manually, without using the electronic eye?

A: Yes. Press the on/off button and water will start flowing. To turn water off, press on/off button again. If you forget to turn the water off, the faucet will automatically turn it off after 60 seconds.

Q: What is the optimal sensing distance?

A: About 2" from sensor.

Q: Does the electronic eye require special maintenance?

A: In order for the sensor to function, the electronic eye must be clean. Use only mild soaps and water. Wipe with a soft cloth.

Q: Why doesn't the water shut itself off after I have moved my hands away from the electronic eye?

A: Sensor range could be too long. User may have to adjust sensor range.

Q: No water will come out of the faucet and the red LED stays on. What is the problem?

A: Replace the batteries.



016647-45



5EF-0002



5EF-0006



017195-45

General Instructions

TROUBLESHOOTING GUIDE

PROBLEM	POSSIBLE CAUSE/SOLUTION
<p>No Water When Activated Red LED in electronic eye</p>	<p>If red LED stays on or is flashing:</p> <ol style="list-style-type: none"> 1. Replace batteries and/or make sure transformer is plugged in 2. If appropriate action from no. 1 does not correct problem: <ul style="list-style-type: none"> • Sensor range too long/picking up sink. Reduce range. • Sensor is faulty; replace sensor module.
<p>Very Low Flow or Slow Dribble</p>	<ol style="list-style-type: none"> 1. Check supply stop(s); open if closed. 2. Debris in solenoid filter; remove, clean and reinstall. 3. Debris in aerator or spray head; remove, clean and reinstall
<p>False Triggering (Unit goes on by itself)</p>	<ol style="list-style-type: none"> 1. Range too long; decrease detection zone. Check surroundings for factors that can contribute to the range; for example, bright lights, highly reflective surfaces, sunlight, etc.
<p>Continues to Run (Even after power to faucet has been disconnected)</p>	<ol style="list-style-type: none"> 1. Debris in solenoid valve, won't close properly. 2. Control module is faulty; replace control module.

RELATED T&S BRASS PRODUCT LINE

T&S BRASS AND BRONZE WORKS, INC.

A firm commitment to application-engineered plumbing products

2 Saddleback Cove, P.O. Box 1088,
Travelers Rest, SC 29690

Phone: (864) 834-4102

Fax: (864) 834-3518

E-mail: tsbrass@tsbrass.com

T & S Brass-Europe
'De Veenhoeve'

Oude Nieuwveenseweg 84

2441 CW Nieuwveen

The Netherlands



RELIABILITY BUILT IN[®]