



Water Connects Us™

Model

### WETS 9003-1.6

Two Piece Floor Mounted Elongated Toilet Tank System

#### DESCRIPTION

Complete two piece vitreous china, elongated, floor mounted toilet tank system.

#### Flush Cycle

☐ Model WETS-9003.9013-1.6 gpf/6.0 Lpf (Left Handle)

- ST-9003-A 1.6 gpf Bowl  
Code: 2109003
- ST-9013-A 1.6 gpf Left Handle Tank  
Code: 2109013

☐ Model WETS-9003.9113-1.6 gpf/6.0 Lpf (Right Handle)

- ST-9003-A 1.6 gpf Bowl  
Code: 2109003
- ST-9113-A 1.6 gpf Right Handle Tank  
Code: 2109113



Left Handle Model Shown

#### SPECIFICATIONS

Quiet, two piece toilet tank system with vitreous china floor mounted elongated water closet and compact tank for left or right handle with the following features:

#### Two Piece Toilet System

- Vitreous china
- Siphon jet flushing action
- Elongated bowl
- 12" rough-in
- 3" valve opening for better flush performance
- Color matched floor caps
- 2 1/8" fully glazed trapway
- Tank and bowl must be ordered as two (2) separate items
- Water spot area 7 7/8" x 6 1/4"
- Water supply & toilet seat not included
- Compatible with toilet seat models:  
Olsonite 10CT, Bemis 1955CT & Church Commercial 295CT
- Toilet tank system is in compliance to the applicable sections of ASME A12.19.2/CSA B45.0/CSA B45.1
- 1,000g maximum performance (Map) score

#### FEATURES

##### Performance

Sloan's toilet tank system incorporates a high performance flapper flush valve to ensure an efficient and optimum flushing performance. 3" valve opening offers better waste removal and powerfully clears the bowl.

##### Colors and Accessories

Available in the color White with polished chrome left or right trip handle. For additional information refer to our price book.

##### Functional

The tank valve provides a 1.6 gpf low consumption flush. Durable construction provides non-corrosive dependability. Anti-siphon ballcock allows reliable operation at high or low water pressures. Adjustment screw allows water level adjustment for individual preference.

##### Economical

Efficient Toilet tank system provides additional savings in water usage. Reduces maintenance and operation costs. Designed for commercial use and also ideal for residential.

##### Warranty

3 year (limited)

#### Product Specification

Elongated toilet tank system shall be made of vitreous china. Toilet tank system shall be installed at required height of 29" from floor to top of tank fixture. Toilet tank system shall be floor mounted. Toilet tank system shall include floor mount bolts and caps. Toilet tank system shall be a 1.6 gpf. Toilet tank system shall be Sloan model WETS-9003.9013-1.6 (left handle) or Sloan model WETS-9003.9113-1.6 (right handle).



Listed by I.A.P.M.O.

This space for Architect/Engineer approval	
Job Name	Date
Model Specified	Quantity
Variations Specified	
Customer/Wholesaler	
Contractor	
Architect	

The information contained in this document is subject to change without notice.



Sloan Valve Company  
 10500 Seymour Avenue  
 Franklin Park, IL 60131  
 Phone: 1-800-9-VALVE-9 (982-5839)  
 or 1-847-671-4300  
 Fax: 1-800-447-8329  
 or 1-847-671-4380  
 www.sloanvalve.com

Copyright © 2014 Sloan Valve Company  
WETS-9003-1.6 (11-14)

### DESCRIPTION

Complete two piece vitreous china, elongated, floor mounted toilet tank system.

#### Flush Cycle

□ Model WETS-9003.9013-1.6 gpf/6.0 Lpf (Left Handle)

- ST-9003-A 1.6 gpf Bowl
- ST-9013-A 1.6 gpf Left Handle Tank

□ Model WETS-9003.9113-1.6 gpf/6.0 Lpf (Right Handle)

- ST-9003-A 1.6 gpf Bowl
- ST-9113-A 1.6 gpf Right Handle Tank

### DIMENSIONS/ROUGH-IN

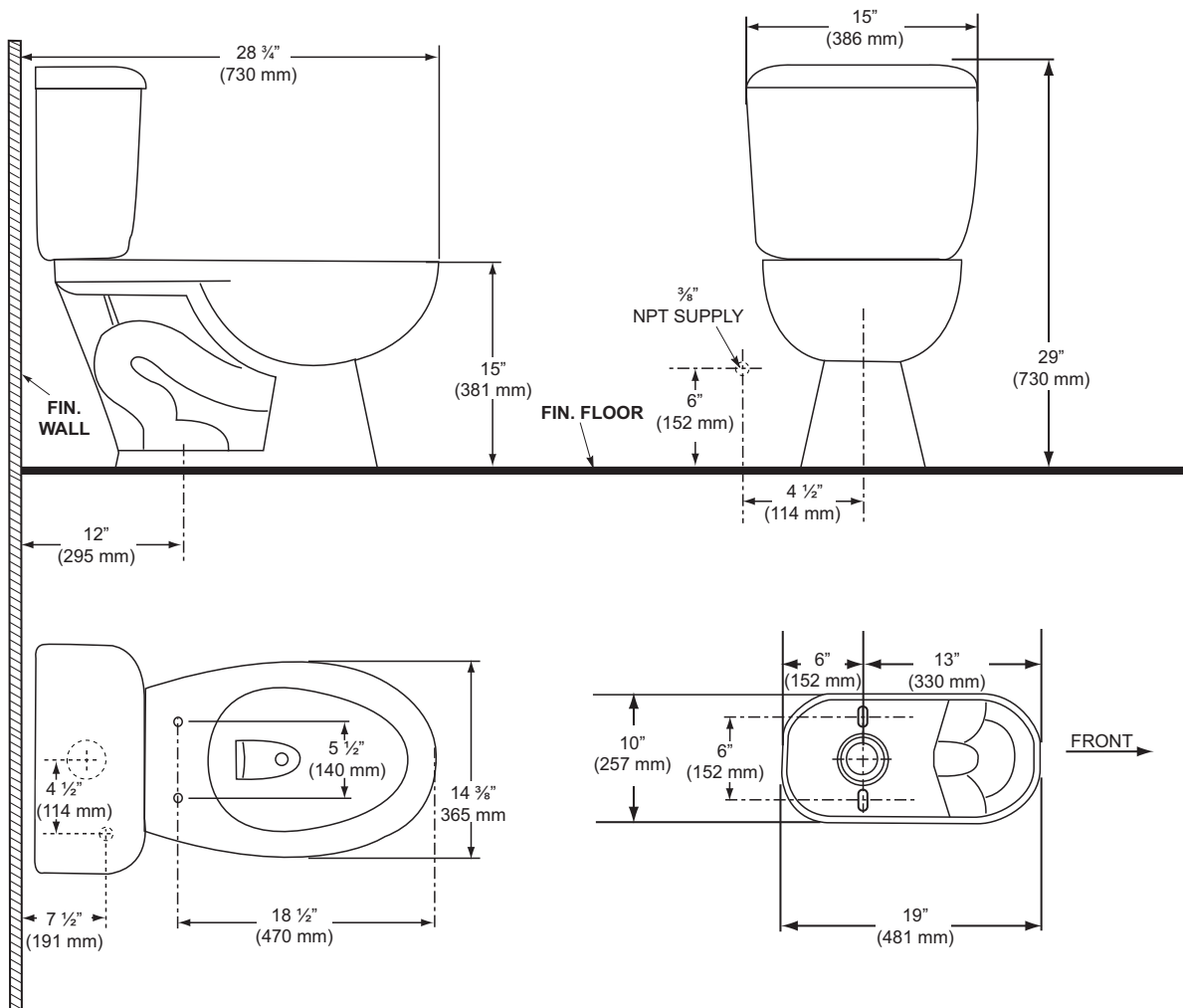

**NOTE:** All vitreous china dimensions shown in these drawings are nominal. Dimensions can vary within the tolerances established in the governing ASME A112.19.2/CSA B45.1 standard. Please take this into consideration when planning rough-in and plumbing layouts.

**SLOAN VALVE COMPANY • 10500 SEYMOUR AVENUE • FRANKLIN PARK, IL 60131**

Phone: 1-800-9-VALVE-9 or 1-847-671-4300 • Fax: 1-800-447-8329 or 1-847-671-4380 • www.sloanvalve.com