



# The Green Solution

## Inline 4" Floor Drain Trap Sealer

### Model SS4009



**Specification:** Sure Seal Model SS4009 preassembled Inline Floor Drain Trap Sealer. 2 pieces: 1 commercial grade ABS plastic housing & proprietary neoprene rubber diaphragm with 1 soft rubber sealing gaskets. Floor rating ASSE – 1072 AF-GW.

**Function:** Inline 4" Floor Drain Trap Sealer. Creates a physical barrier to block sewer gases and their odors from escaping. Can be used in either the strainer or in the floor drain outlet.

· **New Construction:** Used in floor drains to provide added protection against escaping sewer gases. Can be used in either the strainer or in the floor drain outlet. Eliminates the need to repair/replace trap primers when they fail.

· **Retrofit:** Used in situations where trap primers have failed or where trap primers were never installed.

**Benefits:** Simple to install, eliminates the need for complex, time consuming, and expensive repairs. Provides added protection against noxious sewer gasses. ECO friendly saving water.

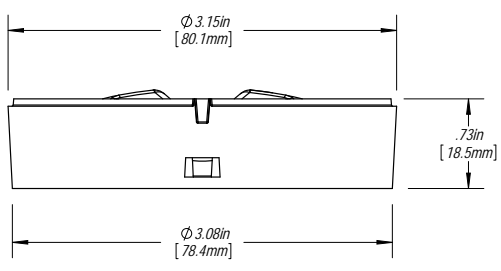
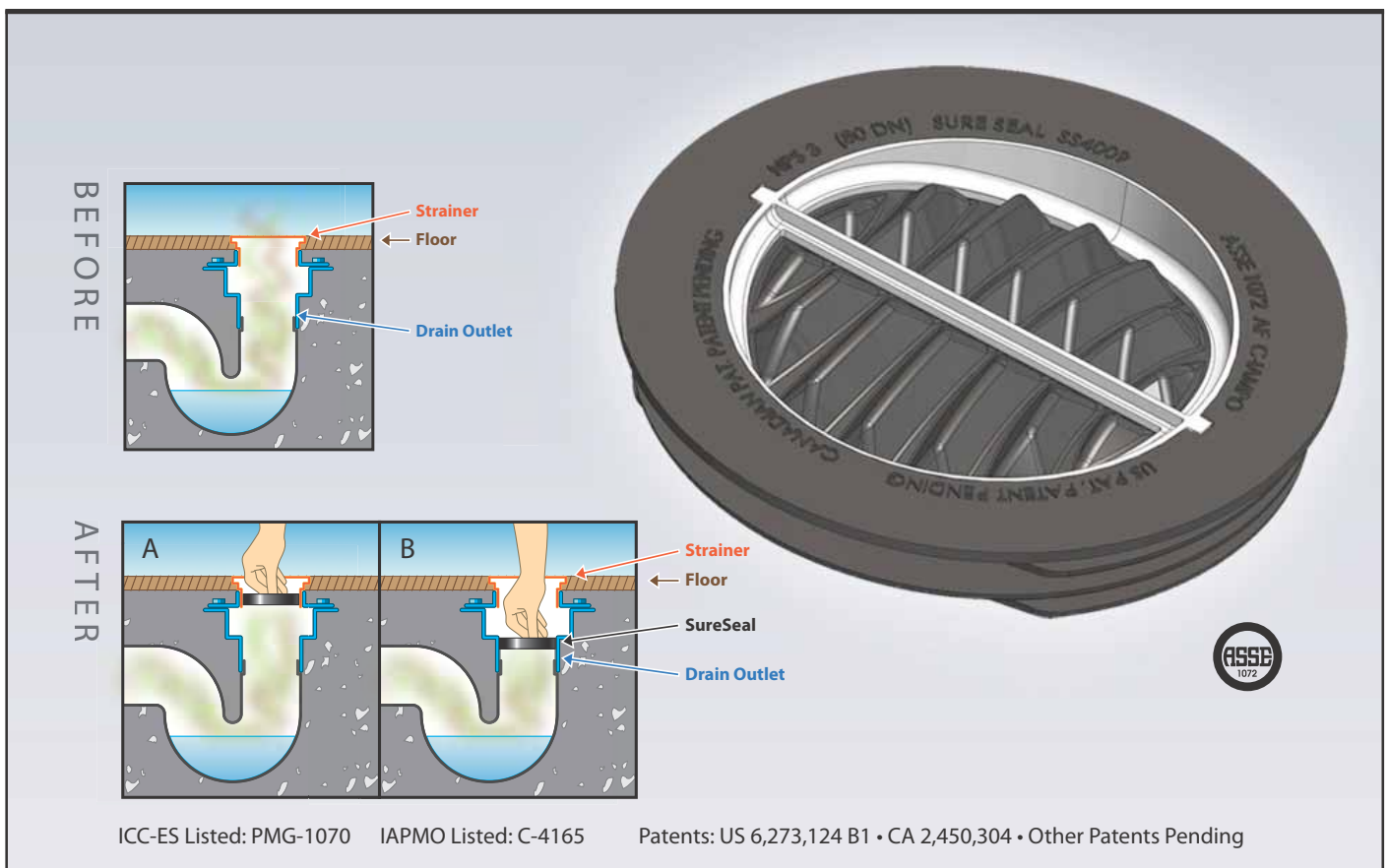

Housing (No Gasket)

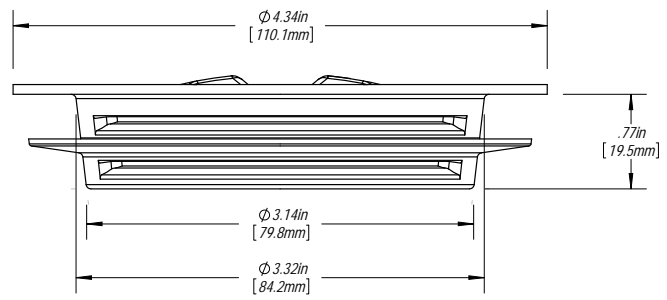

Housing & Gasket