



STA-RITE[®] RESIDENTIAL WATER SYSTEMS

PUMPS, TANKS AND CONTROLS

WWW.STA-RITE.COM



PENTEK® XE-SERIES® SUBMERSIBLE MOTORS

IT'S A MATTER OF TRUST.

You should never install a pump without a motor you can trust for performance and reliability.

Pentek XE Series 4" submersible motors consistently deliver outstanding performance through years of operation in the field... performance that has earned the trust of water well professionals.

XE Series quality comes from the latest design, manufacturing and testing technology. We never compromise on quality, because at the end of the day, your trust is all that matters.

And now, NEW 10 HP motors join the Pentek XE Series... a full line offering a choice for every 4" water well application.



Table of Contents

PRODUCT SELECTION GUIDE	3-5
SUBMERSIBLE PUMPS	
HS+ Series Stainless Steel	6-8
HS Series 5 and 7 GPM TrimLine™ 4" Stainless Steel	9-13
HS Series 10, 15, 20, 30 and 50 GPM 4" Stainless Steel	14-24
JP Series 5 and 7 GPM TrimLine 4" Composite	25-29
JP Series 10, 15, 20 and 30 GPM 4" Composite	30-37
70 GPM 4" Submersible Pump	38-40
90 GPM 4" Submersible Pump	41-43
4" to 6" Submersible Motor Adapter	44
PENTEK® MOTORS AND CONTROLS	
Pentek® XE Series™ 4" Submersible Motors	45-47
Cable Selection 4" Submersible Motors	48-49
Pentek XE Series Coal Bed Methane Motors	50-51
Submersible Motor Controls	52-53
Single-Phase Pump Protection	54-57
Pentek Intellidrive™	58-59
Pentek Intellikit™	60-61
Pentek Pump Controllers	62-63
6" Submersible Motors	64-67
SHALLOW WELL JET PUMPS	
CJ Self-Priming	68-69
HN Self-Priming Cast Iron	70-71
SN Self-Priming Cast Iron	72-73
FN Self-Priming Cast Iron	74-75
PN Self-Priming Corrosion-Resistant	76-77
CONVERTIBLE DEEP WELL JET PUMPS	
HL Self-Priming Cast Iron	78-81
SL Self-Priming Cast Iron	82-85
FL Self-Priming Cast Iron	86-88
PL Corrosion-Resistant	89-91
HMS Horizontal Multi-Stage Jet/Centrifugal	92-95

(Continued on next page)

Table of Contents

CONVERTIBLE DEEP WELL JET PUMPS (CONT'D)

Jet Tank Packages	96-97
MS Vertical Multi-Stage.....	98-100
SSJ Vertical Single-Stage	101-103

JET PACKAGES AND ACCESSORIES	104-107
---	----------------

TANKS

Pro-Source™ Composite Fibrewound Pressure.....	108-110
Pro-Source Composite Fibrewound Contact and Sideport Contact	111-112
Pro-Source PLUS Steel Pressurized.....	113-115
Pro-Source Steel Pressurized	116-120
Pro-Source Epoxy Lined	121-122

CENTRIFUGAL AND UTILITY PUMPS

DSS4HG Pro-Storm™ Self-Priming Multi-Stage.....	123-124
DS3 Pro-Storm Self-Priming Cast Iron	125-127
PD Self-Priming Corrosion-Resistant.....	128-129
D Self-Priming Cast Iron	130-133
CC Straight Centrifugal Cast Iron.....	134-135
DPC Self-Priming Cast Iron.....	136-137
J/JB General Purpose Cast Iron.....	138-140
HP/HPS High-Pressure Booster	141-144
Pro-Source Pumper.....	145-146
EDD/EEDD Engine-Driven Self-Priming	147-148

GENERAL INFORMATION

Water Systems Product Nomenclature.....	149-150
Sizing Home Water Systems	151
Pipe Friction Loss Charts	152-153
Cable Selection Guide – Hitachi® 6"–8" Submersible Motors.....	154-157
Cable Selection Guide – Pentek 6" Submersible Motors.....	154-157

IMPORTANT NOTES

Specifications and/or materials are subject to change without notice.
Dimensions are for estimating purposes only.
Products are tested and rated in accordance with
Water Systems Council Standards.

Delrin® is a registered trademark of E.I. DuPont de Nemours and Co.
Lexan® and Noryl® are registered trademarks of General Electric Co.
Nylatron® is a registered trademark of Polymer Corp.
Hitachi® is a registered trademark of Hitachi Industrial Equipment Systems
Co., Ltd.
All other brand or product names are trademarks or registered trademarks of
Pentair Ltd.

Product Selection Guide



PENTEK® MOTORS AND CONTROLS					
PRODUCT TYPE	4" SUBMERSIBLE MOTORS	SUBMERSIBLE MOTOR CONTROLS	SINGLE-PHASE MOTOR PROTECTORS	CONSTANT PRESSURE CONTROLLER	6" SUBMERSIBLE MOTORS
APPLICATION	Water systems for residential, industrial, commercial, multiple housing and farm clean water use	Water systems for residential, industrial, commercial, multiple housing and farm clean water use	Water systems for residential, industrial, commercial, multiple housing and farm clean water use	Residential, commercial and irrigation constant pressure systems	Water systems for residential, industrial, commercial, multiple housing and farm clean water use
DESCRIPTION	Single- and three-phase 4" submersible high thrust motor	Single-phase motor controls for submersible applications	Single-phase motor protectors for submersible applications	Constant pressure controller for below and above ground applications	Single- and three-phase 6" submersible motor
MATERIALS	Stainless steel construction	NEMA 3R Enclosure	NEMA 3R Enclosure	NEMA 3R Enclosure	Corrosion-resistant components
PERFORMANCE					
Capacity	N/A	N/A	N/A	N/A	N/A
Head	N/A	N/A	N/A	N/A	N/A
SUCTION/DISCHARGE	N/A	N/A	N/A	N/A	N/A
HORSEPOWER	1/2 to 10 HP	1/2 to 15 HP	1/3 to 15 HP	1/2 to 3 HP	5 to 60 HP
SERIES	XE	SMC	SPP	PID	6-inch

Product Selection Guide

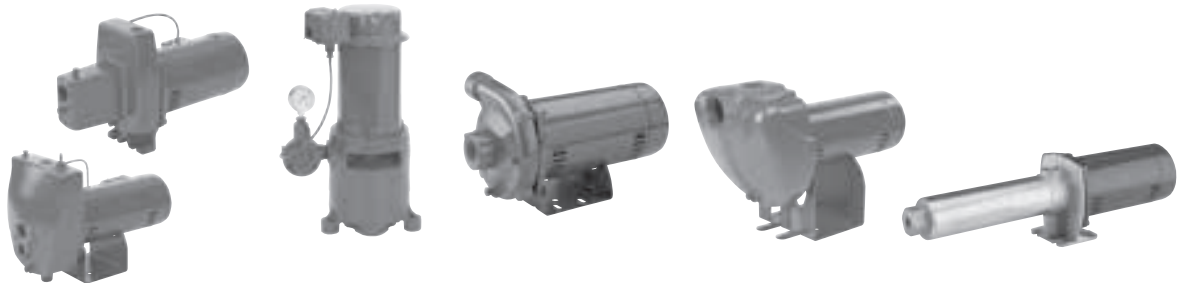

PRODUCT TYPE	SELF-PRIMING SHALLOW WELL AND CONVERTIBLE JET	VERTICAL SINGLE & MULTI-STAGE AND SELF-PRIMING HORIZONTAL MULTI-STAGE DEEP WELL JET	SMALL, STRAIGHT CENTRIFUGAL	SELF-PRIMING CENTRIFUGAL	HIGH PRESSURE BOOSTER PUMPS
APPLICATION	Residential and general water supply systems booster, and light irrigation	General water supply, booster and light irrigation for 2", 3" and 4" or larger water wells	General purpose, process, booster and liquid transfer	Lawn sprinkling, light irrigation, general dewatering and sump drainage, liquid transfer	General purpose booster, warm and cold water wash down, cleaning
DESCRIPTION	Threaded connections Motor-drive Mechanical seal Back pull-out design Convertible to deep well use	Threaded connections Motor-drive Mechanical seals	Threaded connections Motor-drive, ODP and TEFC Mechanical seals – standard and high temperature Back pull-out design 4-position discharge	Fast priming Threaded connections Motor- and engine-drive Portable or permanent installation Mechanical seals Back pull-out design	Threaded connections Motor-drive Mechanical seals ODP and TEFC motors
MATERIALS	Cast iron or fiberglass reinforced thermoplastic with thermoplastic impellers	Cast iron with thermoplastic impellers	Cast iron with bronze (high temperature) or thermoplastic impellers	Cast iron or fiberglass reinforced thermoplastic with bronze, cast iron or thermoplastic impellers	Signature 2000® – Stainless steel or cast iron construction with thermoplastic impellers/diffusers
PERFORMANCE					
Capacity	To 45 GPM	To 55 GPM	To 260 GPM	To 240 GPM	To 40 GPM
Head	To 160 TDH/ft.	To 325 TDH/ft.	To 140 TDH/ft.	To 160 TDH/ft.	To 690 TDH/ft.
SUCTION/DISCHARGE	1" to 1-1/4" 3/4" to 1"	1-1/4" suction, 1" drive 1"	1-1/4" to 2-1/2" 1" to 2"	1" to 3" 1" to 2-1/2"	3/4" to 1-1/4" 1" to 1-1/2"
HORSEPOWER	1/3 to 1-1/2 HP	1/2 to 2 HP	1/3 to 5 HP	1/2 to 5 HP	1/2 to 3 HP
SERIES	SN, HN, FN, PN, SL, HL, FL, PL	SSJ, MS, HMS	J/JB, CC	D, DS3, EDD, DPC, PD	HP, HPS

Product Selection Guide



6" STAINLESS STEEL SUBMERSIBLE TURBINE	4" SUBMERSIBLE	WATER SYSTEMS TANKS		
		PRO-SOURCE® COMPOSITE PRESSURIZED FIBREWOUND	PRO-SOURCE PRO-SOURCE PLUS PRESSURIZED STEEL	PRO-SOURCE COMPOSITE CONTACT & SIDEPORT CONTACT "AIR OVER WATER" STEEL
General water supply, irrigation, booster, sump, circulation, dewatering	General water supply, booster, sump, circulation, and irrigation	General water storage and transfer	General water storage and transfer	General water storage and transfer
Threaded connections Completely submerged sealed motor coupled to pump	Threaded connections Completely submerged sealed motor 2 and 3 wire	Pre-pressurized composite well tank CSA Classified to ANSI/NSF 61 Field serviceable	Pre-pressurized steel well tank CSA Classified to ANSI/NSF 61	Air over water standard tank
All stainless steel construction	Signature 2000® – Stainless steel and composite construction with thermoplastic impellers/diffusers 70 GPM Series – Cast iron bowls with thermoplastic impellers 90 GPM High-Flo Series	Pressure vessel: polyethylene Exterior: continuous, overlapping fiberglass strands, sealed with high-grade epoxy resin, then oven-cured	Pressure vessel: steel Exterior: baked-on powder polyester paint Water separator: PVC	Pressure vessel: steel Exterior: baked-on powder polyester paint Interior: baked-on epoxy paint
To 365 GPM To 1400 TDH/ft.	To 125 GPM To 1900 TDH/ft.	Physical Capacity: 14 - 119 gallons Drawdown: 5.3 - 43.8 gallons Maximum operating pressure: 125 PSI	Physical Capacity: 2 - 119 gallons Drawdown: 0.7 - 41.3 gallons Maximum operating pressure: 125 PSI	Physical Capacity: 30 - 264 gallons Drawdown: 7 - 50 gallons Maximum operating pressure: 100 PSI
3" to 4"	1-1/4" to 2"	1" to 1-1/4" NPT	3/4" to 1-1/4" NPT	1-1/4" NPT
1 to 60 HP	1/2 to 10 HP	N/A	N/A	N/A
L6TS	Signature 2000 Series, 70 GPM Series and 90 GPM Series	Pro-Source Composite	Pro-Source Plus	Pro-Source Composite

HS+ Series Signature 2000®

Stainless Steel



POWERED BY
PENTEK®



HS+ Series SubPAK

Ships complete with HS+ Series pump, XE Series motor and SMC-CR Control Box. Factory assembled and tested.

Precision-engineered, high-quality, rugged Signature 2000® Stainless Steel Series Pumps deliver efficient, dependable performance even in rough, aggressive water.

The Signature 2000 HS+ series puts the plus in HS+ with the advanced Pentek® XE Series™ motor. Superior Pentek motor technology supercharges an HS+ pump with extra stages, raising the performance bar without exceeding recommended service factor amps.

APPLICATIONS

Water systems...for residential, industrial, commercial, multiple housing and farm use.

SPECIFICATIONS

Shell: Stainless steel

Diameter: 3-7/8"

Discharge: Stainless steel

Discharge Bearing: Nylatron®

Intermediate Bearing: (On larger units) polycarbonate, nitrile rubber and stainless steel

Impellers: Acetal

Diffusers: Polycarbonate

Suction Caps: Polycarbonate with stainless steel insert

Thrust Pads: Proprietary spec.

Shaft and Coupling: Stainless steel

Intake: Stainless steel

Intake Screen: Stainless steel

Cable Guard: Stainless steel

Check Valve: Acetal†

Agency Listings: CSA

FEATURES

Proven Staging System: Our proven SignaSeal™ staging system incorporates a harder-than-sand ceramic wear surface that when incorporated with our floating impeller design, greatly reduces problems with abrasives, sand lock-up and running dry.

Discharge: Corrosion-resistant 300 grade stainless steel for durability in aggressive water. Large octagon wrench area for ease of installation.

Discharge Bearing: Exclusive self-lubricating Nylatron bearing resists wear from sand.

Intake: Corrosion-resistant 300 grade stainless steel for durability in aggressive water.

Shaft: Positive drive from 7/16" hexagonal heavy-duty 300 grade stainless steel.

Coupling: Stainless steel press fit to pump shaft. Couples to all standard NEMA motors.

Shell: Heavy-walled corrosion-resistant 300 grade stainless steel. Threaded for easy servicing.

Hardware: All screws, washers and nuts are corrosion-resistant 300 grade stainless steel.

Check Valve†: Durable internal spring-loaded check valve.

Cable Guard: Corrosion-resistant stainless steel guard protects motor leads. Tapered ends prevent pump from catching on well.

Intake Screen: Corrosion-proof.

Pentek® XE Series™ Motor: 2 and 3 wire NEMA standard all stainless construction water-filled motors.

†Except where noted.

Nylatron® is a registered trademark of Polymer Corp. All other brand or product names are trademarks or registered trademarks of Pentair Ltd.



HS+ Series Signature 2000®

Stainless Steel

ORDERING INFORMATION

HP	STGS.	PH	VOLTS	ASSEMBLED PUMP		
				CATALOG NUMBER	LENGTH INCHES	WT. LBS.
5 GPM/3 WIRE						
1/2	15	1	230	S5P4HS+05231	29	26
3/4	21	1	230	S5P4HS+07231	35-1/4	32
1	24	1	230	S5P4HS+10231	38-3/4	32
7 GPM/3 WIRE						
1/2	12	1	230	S7P4HS+05231	27	26
3/4	15	1	230	S7P4HS+07231	30-3/4	30
1	19	1	230	S7P4HS+10231	35-1/2	30
10 GPM/3 WIRE						
1/2	9	1	230	S10P4HS05231PLUS	24-3/4	26-1/2
3/4	12	1	230	S10P4HS07231PLUS	27-3/4	29-1/2
1	15	1	230	S10P4HS10231PLUS	30-3/4	29-1/2
15 GPM/3 WIRE						
1/2	7	1	230	S15P4HS+05231	24-1/2	27
3/4	9	1	230	S15P4HS+07231	28	30
1	11	1	230	S15P4HS+10231	31-1/2	30
20 GPM/3 WIRE						
3/4	7	1	230	S20P4HS+07231	26	29
1	9	1	230	S20P4HS+10231	29-1/2	29

OUTLINE DIMENSIONS

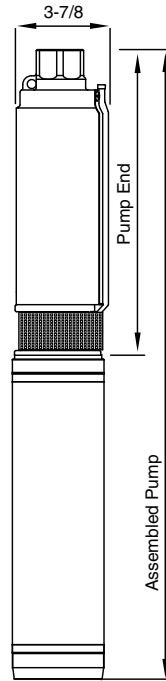

DISCHARGE

5 GPM	1-1/4" NPT
7 GPM	1-1/4" NPT
10 GPM	1-1/4" NPT
15 GPM	1-1/4" NPT
20 GPM	1-1/4" NPT

For dimensions, refer to Ordering Information table.

Dimensions (in inches) are for estimating purposes only.

PUMP PERFORMANCE: 5 GPM

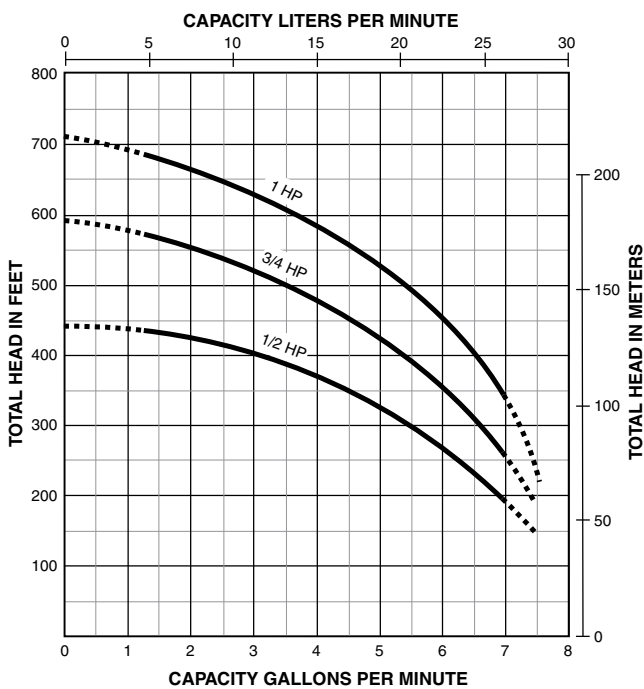

PUMP PERFORMANCE: 7 GPM

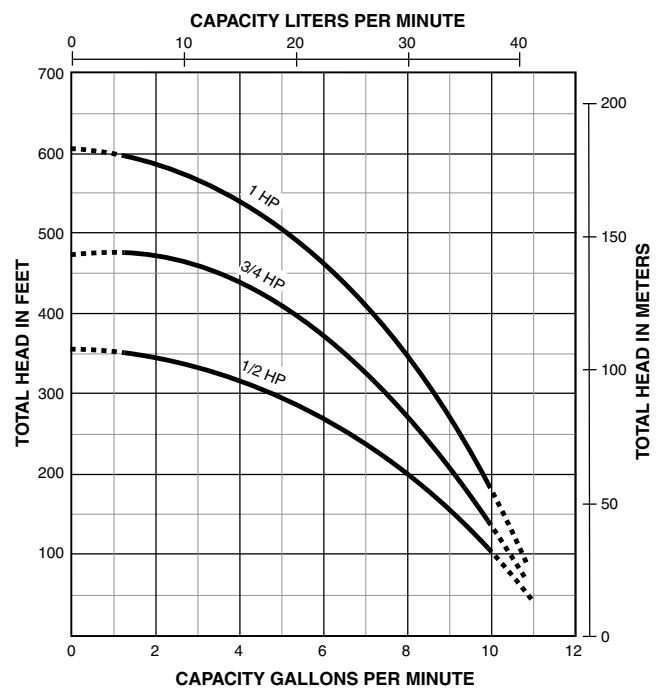

HS+ Series Signature 2000®

Stainless Steel

PUMP PERFORMANCE: 10 GPM

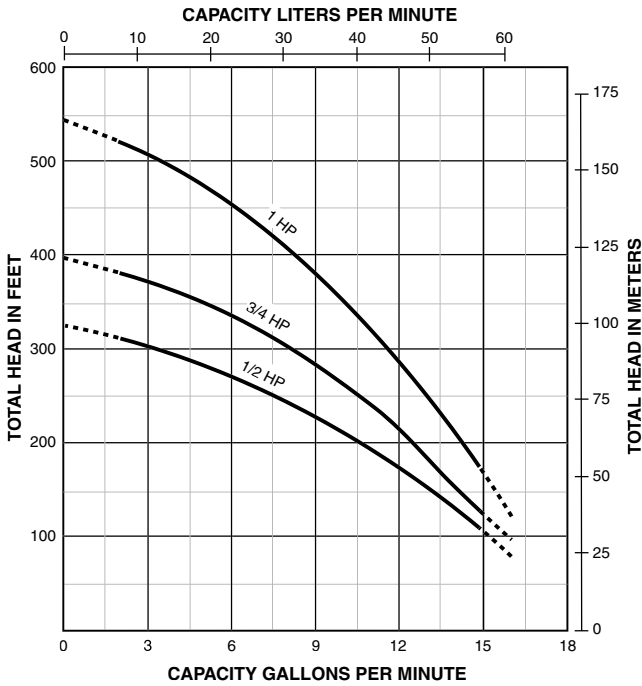

PUMP PERFORMANCE: 15 GPM

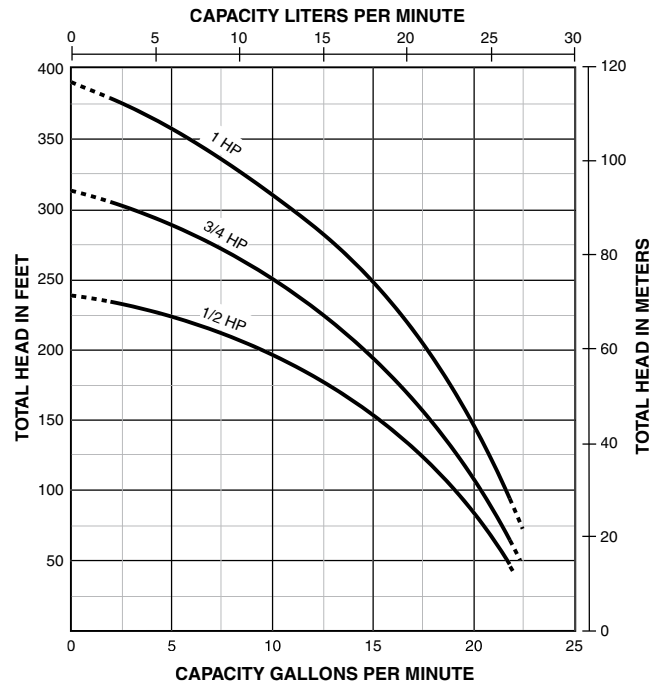

PUMP PERFORMANCE: 20 GPM

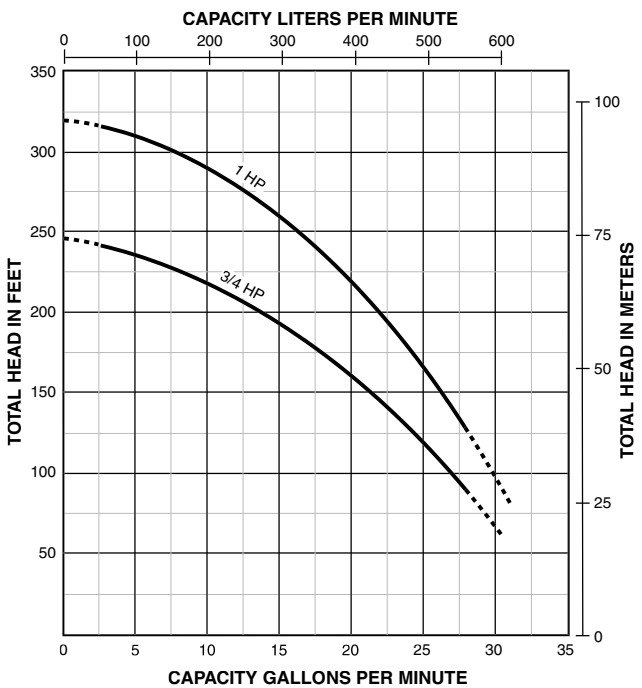

HS Series Signature 2000® 5 and 7 gpm TrimLine™

Stainless Steel



POWERED BY
PENTEK®



Precision-engineered, high-quality, rugged Signature 2000® Stainless Steel Series Pumps deliver efficient, dependable performance even in rough, aggressive water.

The TrimLine™ 5 and 7 GPM Series Pumps are 3-3/4" maximum O.D. Heads to 1,150 feet and capacities to 10.5 GPM. Built to deliver long-term, trouble-free service. Floating impeller design resists sand and reduces sand locking. These pumps feature the proven SignaSeal™ staging system.

APPLICATIONS

Water systems...for residential, industrial, commercial, multiple housing and farm use.

SPECIFICATIONS

Shell: Stainless steel

Discharge: Stainless steel

Discharge Bearing: Nylatron®

Intermediate Bearing: (On larger units) polycarbonate, nitrile rubber and stainless steel

Impellers: Acetal

Diffusers: Polycarbonate

Suction Caps: Polycarbonate with stainless steel insert

Thrust Pads: Proprietary spec.

Shaft and Coupling: Stainless steel

Intake: Stainless steel

Intake Screen: Stainless steel

Cable Guard: Stainless steel

Agency Listings: CSA

Check Valve: Acetal

FEATURES

Proven Staging System: Our proven SignaSeal staging system incorporates a harder-than-sand ceramic wear surface that when incorporated with our floating impeller design, greatly reduces problems with abrasives, sand lock-up and running dry.

Discharge: Corrosion-resistant 300 grade stainless steel for durability in aggressive water. Large octagon wrench area for ease of installation.

Discharge Bearing: Exclusive self-lubricating Nylatron bearing resists wear from sand.

Intake: Corrosion-resistant 300 grade stainless steel for durability in aggressive water.

Shaft: Positive drive from 7/16" hexagonal heavy-duty 300 grade stainless steel.

Coupling: Stainless steel press fit to pump shaft. Couples to all standard NEMA motors.

Shell: Heavy-walled corrosion-resistant 300 grade stainless steel. Threaded for easy servicing.

Hardware: All screws, washers and nuts are corrosion-resistant 300 grade stainless steel.

Check Valve: Durable internal spring-loaded check valve.

Cable Guard: Corrosion-resistant stainless steel guard protects motor leads. Tapered ends prevent pump from catching on well.

Intake Screen: Corrosion-proof stainless steel.

Pentek® XE Series™ Motor: 2 and 3 wire NEMA standard all stainless construction water-filled motors.

Nylatron® is a registered trademark of Polymer Corp.
All other brand or product names are trademarks or registered trademarks of Pentair Ltd.

HS Series Signature 2000[®] 5 and 7 gpm TrimLine[™]

Stainless Steel

ORDERING INFORMATION

GPM	MOTOR TYPE	HP	STGS.	PH	VOLT	ASSEMBLED PUMP			PUMP END			MOTOR		CONTROL BOX	
						CATALOG NUMBER	LENGTH IN.*	WEIGHT LBS.*	CATALOG NUMBER	LENGTH IN.*	WEIGHT LBS.*	CATALOG NUMBER	WEIGHT LBS.*	CATALOG NUMBER	WEIGHT LBS.*
5	2 WIRE	1/2	13	1	115	S5P4HS05121	27-1/2	28	L5P4CHL	18	12	P42B0005A1	19		
		1/2	13	1	230	S5P4HS05221	27-1/2	28	L5P4CHL	18	12	P42B0005A2	19		
		3/4	18	1	230	S5P4HS07221	32-3/4	34	L5P4DHL	22	15	P42B0007A2	23		
		1	22	1	230	S5P4HS10221	37	39	L5P4EHL	25-1/4	17	P42B0010A2	25		
		1-1/2	30	1	230	S5P4HS15221	47	51	L5P4FHL	32	21	P42B0015A2	29		
	3 WIRE	1/2	13	1	115	S5P4HS05131	27-1/2	28	L5P4CHL	18	12	P43B0005A1	19	SMC-IR0511	4
		1/2	13	1	230	S5P4HS05231	27-1/2	28	L5P4CHL	18	12	P43B0005A2	18	SMC-CR0521	4
		3/4	18	1	230	S5P4HS07231	32-3/4	34	L5P4DHL	22	15	P43B0007A2	21	SMC-CR0721	4
		1	22	1	230	S5P4HS10231	37	39	L5P4EHL	25-1/4	17	P43B0010A2	23	SMC-CR1021	4
		1-1/2	30	1	230	S5P4HS15231	45-1/2	48	L5P4FHL	32	21	P43B0015A2	27	SMC-CR1521	7
		1-1/2	30	3	230				L5P4FHL	32	21	P43B0015A3	23		
		1-1/2	30	3	460				L5P4FHL	32	21	P43B0015A4	23		
		2	38	1	230				L5P4GHL	37-3/4	25	P43B0020A2	31	SMC-CR2021	7
		2	38	3	230				L5P4GHL	37-3/4	25	P43B0020A3	23		
2	38	3	460				L5P4GHL	37-3/4	25	P43B0020A4	23				
7	2 WIRE	1/2	10	1	115	S7P4HS05121	25-1/2	27	L7P4CHL	16	11	P42B0005A1	19		
		1/2	10	1	230	S7P4HS05221	25-1/2	27	L7P4CHL	16	11	P42B0005A2	19		
		3/4	13	1	230	S7P4HS07221	29	32	L7P4DHL	18-1/2	13	P42B0007A2	23		
		1	17	1	230	S7P4HS10221	33-3/4	37	L7P4EHL	22	15	P42B0010A2	25		
		1-1/2	22	1	230	S7P4HS15221	42-1/2	47	L7P4FHL	27-1/4	17	P42B0015A2	29		
		1-1/2	22	3	230				L7P4FHL	27-1/4	17	P43B0015A3	23		
	3 WIRE	1/2	10	1	115	S7P4HS05131	25-1/2	27	L7P4CHL	16	11	P43B0005A1	19	SMC-IR0511	4
		1/2	10	1	230	S7P4HS05231	25-1/2	27	L7P4CHL	16	11	P43B0005A2	18	SMC-CR0521	4
		3/4	13	1	230	S7P4HS07231	29	32	L7P4DHL	18-1/2	13	P43B0007A2	21	SMC-CR0721	4
		1	17	1	230	S7P4HS10231	33-3/4	37	L7P4EHL	22	15	P43B0010A2	23	SMC-CR1021	4
		1-1/2	22	1	230	S7P4HS15231	41	44	L7P4FHL	27-1/4	17	P43B0015A2	27	SMC-CR1521	7
		1-1/2	22	3	230				L7P4FHL	27-1/4	17	P43B0015A4	23		
		1-1/2	22	3	460				L7P4FHL	27-1/4	17	P43B0015A4	23		
		2	28	1	230				L7P4GHL	32-1/2	20	P43B0020A2	31	SMC-CR2021	7
		2	28	3	230				L7P4GHL	32-1/2	20	P43B0020A3	27		
		2	28	3	460				L7P4GHL	32-1/2	20	P43B0020A4	27		
		3	36	1	230				L7P4HHL	39-1/2	24	P43B0030A2	37	SMC-CR3021	8
		3	36	3	230				L7P4HHL	39-1/2	24	P43B0030A3	37		
3	36	3	460				L7P4HHL	39-1/2	24	P43B0030A4	37				

*Length and Weight are approximate.

TrimLine[™] version maximum outside diameter is 3-3/4". Standard version maximum outside diameter is 3-7/8".

NOTE: Motor, Control Box or Magnetic Starter must be ordered separately, if ordering pump end only. Discharge NPT is 1-1/4".

HS Series Signature 2000[®] 5 and 7 gpm TrimLine[™]

Stainless Steel

OUTLINE DIMENSIONS

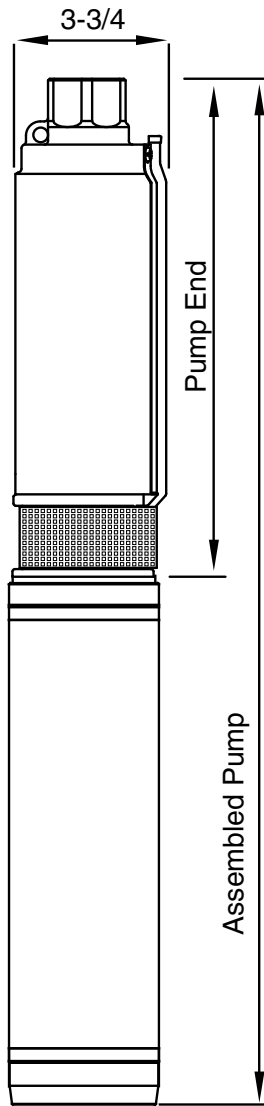

DISCHARGE	
5 GPM	1-1/4" NPT
7 GPM	1-1/4" NPT

For dimensions, refer to Ordering Information table.
 Dimensions (in inches) are for estimating purposes only.

PUMP PERFORMANCE: 5 GPM

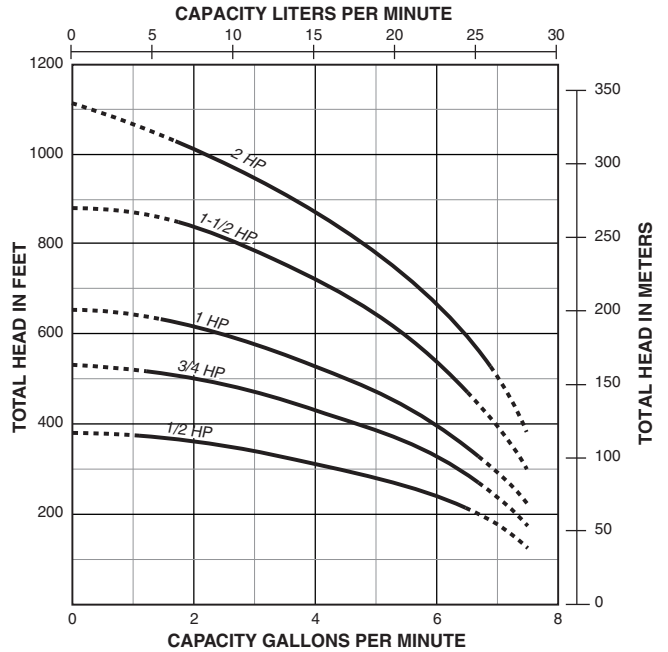

PUMP PERFORMANCE: 7 GPM

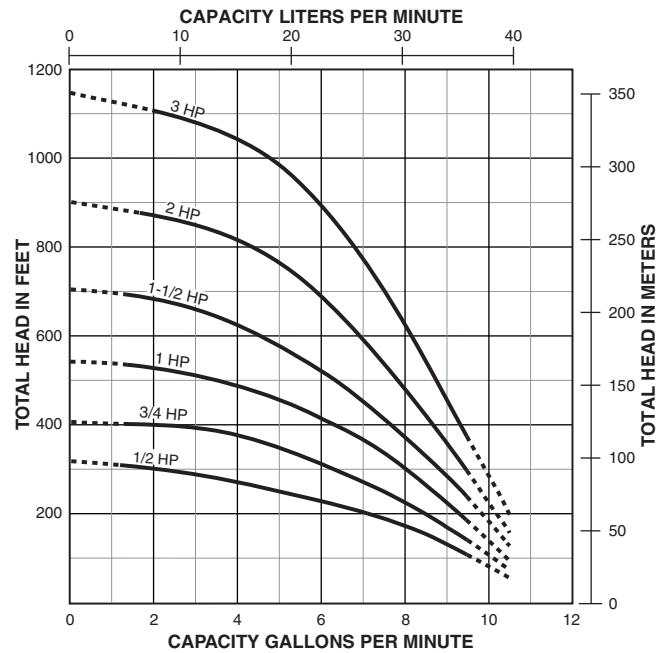

Tested and rated in accordance with Water Systems Council Standards.
 NOTE: Pumps installed with a Pro-Source[®] tank require a 100 PSI relief valve. Pumps installed with a conventional tank require a 75 PSI relief valve.
 Relief valve must be capable of relieving entire flow of pump at relief pressure.

HS Series Signature 2000®

Stainless Steel



POWERED BY
PENTEK®



Precision-engineered, high-quality, rugged Signature 2000® Stainless Steel Series Pumps deliver efficient, dependable performance even in rough, aggressive water. Heads to 1,950 feet and capacities to 65 GPM. Built to deliver long-term, trouble-free service. Floating impeller design resists sand and reduces sand locking. These pumps feature the proven SignaSeal™ staging system.

APPLICATIONS

Water systems...for residential, industrial, commercial, multiple housing and farm use.

SPECIFICATIONS

Shell: Stainless steel

Diameter: 3-7/8"

Discharge: Stainless steel

Discharge Bearing: Nylatron®

Intermediate Bearing: (On larger units) polycarbonate, nitrile rubber and stainless steel

Impellers: Acetal

Diffusers: Polycarbonate

Suction Caps: Polycarbonate with stainless steel insert

Thrust Pads: Proprietary spec.

Shaft and Coupling: Stainless steel

Intake: Stainless steel

Intake Screen: Polypropylene

Cable Guard: Stainless steel

Check Valve: Acetal†

Agency Listings: CSA

FEATURES

Proven Staging System: Our proven SignaSeal staging system incorporates a harder-than-sand ceramic wear surface that when incorporated with our floating impeller design, greatly reduces problems with abrasives, sand lock-up and running dry.

Discharge: Corrosion-resistant 300 grade stainless steel for durability in aggressive water. Large octagon wrench area for ease of installation.

Discharge Bearing: Self-lubricating Nylatron bearing resists wear from sand.

Intake: Corrosion-resistant 300 grade stainless steel for durability in aggressive water.

Shaft: Positive drive from 7/16" hexagonal heavy-duty 300 grade stainless steel.

Coupling: Stainless steel press fit to pump shaft. Couples to all standard NEMA motors.

Shell: Highest grade, heavy-walled corrosion-resistant stainless steel. Threaded for easy servicing.

Hardware: All screws, washers and nuts are corrosion-resistant 300 grade stainless steel.

Check Valve: Durable internal spring-loaded check valve.

Cable Guard: Corrosion-resistant stainless steel guard protects motor leads. Tapered ends prevent pump from catching on well.

Intake Screen: Corrosion-proof.

Pentek® XE Series™ Motor: 2 and 3 wire NEMA standard all stainless construction water-filled motors.

†Except where noted.

Nylatron® is a registered trademark of Polymer Corp.

All other brand or product names are trademarks or registered trademarks of Pentair Ltd.

HS Series Signature 2000®

Stainless Steel

ORDERING INFORMATION

GPM	MOTOR TYPE	HP	STGS.	PH	VOLT	ASSEMBLED PUMP			PUMP END			MOTOR		CONTROL BOX	
						CATALOG NUMBER	LENGTH INCHES*	WEIGHT POUNDS*	CATALOG NUMBER	LENGTH INCHES*	WEIGHT POUNDS*	CATALOG NUMBER	WEIGHT POUNDS*	CATALOG NUMBER	WEIGHT POUNDS*
10**	2 WIRE	1/2	7	1	115	S10P4HS05121	22-3/4	27-1/2	L10P4CH	12-3/4	9	P42B0005A1	19		
		1/2	7	1	230	S10P4HS05221	22-3/4	27-1/2	L10P4CH	12-3/4	9	P42B0005A2	19		
		3/4	10	1	230	S10P4HS07221	25-3/4	30-1/2	L10P4DH	14-1/2	10	P42B0007A2	23		
		1	13	1	230	S10P4HS10221	28-3/4	34-1/2	L10P4EH	16-1/2	10-3/4	P42B0010A2	25		
		1-1/2	17	1	230	S10P4HS15221	34-3/4	41-1/2	L10P4FH	19-3/4	12-1/2	P42B0015A2	29		
	3 WIRE	1/2	7	1	115	S10P4HS05131	22-3/4	27-1/2	L10P4CH	12-3/4	9	P43B0005A1	19	SMC-IR0511	4
		1/2	7	1	230	S10P4HS05231	22-3/4	27-1/2	L10P4CH	12-3/4	9	P43B0005A2	18	SMC-CR0521	4
		3/4	10	1	230	S10P4HS07231	25-3/4	30-1/2	L10P4DH	14-1/2	10	P43B0007A2	21	SMC-CR0721	4
		1	13	1	230	S10P4HS10231	28-3/4	34-1/2	L10P4EH	16-1/2	10-3/4	P43B0010A2	23	SMC-CR1021	4
		1-1/2	17	1	230	S10P4HS15231	33-1/2	41-1/2	L10P4FH	19-3/4	12-1/2	P43B0015A2	27	SMC-CR1521	7
		1-1/2	17	3	230				L10P4FH	19-3/4	12-1/2	P43B0015A3	23		
		1-1/2	17	3	460				L10P4FH	19-3/4	12-1/2	P43B0015A4	23		
		2	22	1	230				L10P4GH	22	13-3/4	P43B0020A2	31	SMC-CR2021	7
		2	22	3	230				L10P4GH	22	13-3/4	P43B0020A3	23		
		2	22	3	460				L10P4GH	22	13-3/4	P43B0020A4	23		
		3	30	1	230				L10P4HH	22	16-3/4	P43B0030A2	40	SMC-CR3021	8
		3	30	3	230				L10P4HH	28	16-3/4	P43B0030A3	32		
		3	30	3	460				L10P4HH	28	16-3/4	P43B0030A4	32		
		5	50	1	230				L10P4JH	43-1/2	25-1/2	P43B0050A2	70	SMC-CR5021	12
		5	50	3	230				L10P4JH	43-1/2	25-1/2	P43B0050A3	55		
5	50	3	460				L10P4JH	43-1/2	25-1/2	P43B0050A4	55				
15**	2 WIRE	1/2	5	1	115	S15P4HS05121	22-1/4	27	L15P4CH	12-1/4	9	P42B0005A1	19		
		1/2	5	1	230	S15P4HS05221	22-1/4	27	L15P4CH	12-1/4	9	P42B0005A2	19		
		3/4	7	1	230	S15P4HS07221	25-3/4	31	L15P4DH	14-1/2	10	P42B0007A2	23		
		1	9	1	230	S15P4HS10221	29-1/4	35	L15P4EH	16-3/4	11	P42B0010A2	25		
		1-1/2	12	1	230	S15P4HS15221	35-1/4	43	L15P4FH	20-1/4	13	P42B0015A2	29		
	3 WIRE	1/2	5	1	115	S15P4HS05131	22-1/4	27	L15P4CH	12-1/4	9	P43B0005A1	19	SMC-IR0511	4
		1/2	5	1	230	S15P4HS05231	22-1/4	27	L15P4CH	12-1/4	9	P43B0005A2	18	SMC-CR0521	4
		3/4	7	1	230	S15P4HS07231	25-3/4	31	L15P4DH	14-1/2	10	P43B0007A2	21	SMC-CR0721	4
		1	9	1	230	S15P4HS10231	29-1/4	35	L15P4EH	16-3/4	11	P43B0010A2	23	SMC-CR1021	4
		1-1/2	12	1	230	S15P4HS15231	33-3/4	41	L15P4FH	20-1/4	13	P43B0015A2	27	SMC-CR1521	7
		1-1/2	12	3	230				L15P4FH	20-1/4	13	P43B0015A3	23		
		1-1/2	12	3	460				L15P4FH	20-1/4	13	P43B0015A4	23		
		2	15	1	230				L15P4GH	23-1/2	15	P43B0020A2	31	SMC-CR2021	7
		2	15	3	230				L15P4GH	23-1/2	15	P43B0020A3	23		
		2	15	3	460				L15P4GH	23-1/2	15	P43B0020A4	23		
		3	22	1	230				L15P4HH	31-1/4	18	P43B0030A2	40	SMC-CR3021	7
		3	22	3	230				L15P4HH	31-1/4	18	P43B0030A3	32		
		3	22	3	460				L15P4HH	31-1/4	18	P43B0030A4	32		

*Length and Weight are approximate.

**For 10 GPM, 15 GPM and 20 GPM discharge is 1-1/4" NPT.

***For 30 GPM and 50 GPM discharge is 2" NPT.

NOTE: On 2 HP and larger – Pump, Motor, Control Box or Magnetic Starter must be ordered separately.

†Check Valve not included on 5 HP, 7-1/2 HP and 10 HP models. Check Valve not included on 50 GPM models.

TrimLine™ version maximum outside diameter is 3-3/4". Standard version maximum outside diameter on all models is 3-7/8".

HS Series Signature 2000®

Stainless Steel

ORDERING INFORMATION

GPM	MOTOR TYPE	HP	STGS.	PH	VOLT	ASSEMBLED PUMP			PUMP END			MOTOR		CONTROL BOX	
						CATALOG NUMBER	LENGTH INCHES*	WEIGHT POUNDS*	CATALOG NUMBER	LENGTH INCHES*	WEIGHT POUNDS*	CATALOG NUMBER	WEIGHT POUNDS*	CATALOG NUMBER	WEIGHT POUNDS*
20**	2 WIRE	3/4	5	1	230	S20P4HS07221	23-3/4	30	L20P4DH	12-1/2	8-1/2	P42B0007A2	23		
		1	7	1	230	S20P4HS10221	27-1/4	34	L20P4EH	14-3/4	9-3/4	P42B0010A2	25		
		1-1/2	9	1	230	S20P4HS15221	32	39	L20P4FH	16-3/4	10-3/4	P42B0015A2	29		
	3 WIRE	3/4	5	1	230	S20P4HS07231	23-3/4	30	L20P4DH	12-1/2	8-1/2	P43B0007A2	23	SMC-CR0721	5
		1	7	1	230	S20P4HS10231	27-1/4	34	L20P4EH	14-3/4	9-3/4	P43B0010A2	25	SMC-CR1021	5
		1-1/2	9	1	230	S20P4HS15231	30-1/2	39	L20P4FH	16-3/4	10-3/4	P43B0015A2	29	SMC-CR1521	7
		1-1/2	9	3	230				L20P4FH	16-3/4	10-3/4	P43B0015A3	23		
		1-1/2	9	3	460				L20P4FH	16-3/4	10-3/4	P43B0015A4	23		
		2	12	1	230				L20P4GH	20-1/4	12-1/2	P43B0020A2	31	SMC-CR2021	7
		2	12	3	230				L20P4GH	20-1/4	12-1/2	P43B0020A3	32		
		2	12	3	460				L20P4GH	20-1/4	12-1/2	P43B0020A4	32		
		3	17	1	230				L20P4HH	25-3/4	15	P43B0030A2	40	SMC-CR3021	7
		3	17	3	230				L20P4HH	25-3/4	15	P43B0030A3	32		
		3	17	3	460				L20P4HH	25-3/4	15	P43B0030A4	32		
		5	28	1	230				L20P4JH	38	21	P43B0050A2	70	SMC-CR5021	8
		5	28	3	230				L20P4JH	38	21	P43B0050A3	55		
		5	28	3	460				L20P4JH	38	21	P43B0050A4	55		
		7-1/2	40	3	230				L20P4KH	53-3/4	30	P43B0075A3	70		
		7-1/2	40	3	460				L20P4KH	53-3/4	30	P43B0075A4	70		
		10	54	3	460				L20P4LH	71	41	P43B0100A4	78		
30***	2 WIRE	1	5	1	230	S30P4HS10221	26-1/2	35	L30P4EH	14	9-3/4	P42B0010A2	25		
		1-1/2	6	1	230	S30P4HS15221	30-1/2	39	L30P4FH	15-1/4	10-3/4	P42B0015A2	29		
	3 WIRE	1	5	1	230	S30P4HS10231	26-1/2	35	L30P4EH	14	10	P43B0010A2	25	SMC-CR1021	5
		1-1/2	6	1	230	S30P4HS15231	29	39	L30P4FH	15-1/4	11	P43B0015A2	29	SMC-CR-1521	7
		1-1/2	6	3	230				L30P4FH	15-1/4	11	P43B0015A3	23		
		1-1/2	6	3	460				L30P4FH	15-1/4	11	P43B0015A4	23		
		2	8	1	230				L30P4GH	18-1/4	12	P43B0020A2	31	SMC-CR2021	7
		2	8	3	230				L30P4GH	18-1/4	12	P43B0020A3	23		
		2	8	3	460				L30P4GH	18-1/4	12	P43B0020A4	23		
		3	12	1	230				L30P4HH	24	15	P43B0030A2	40	SMC-CR3021	7
		3	12	3	230				L30P4HH	24	15	P43B0030A3	32		
		3	12	3	460				L30P4HH	24	15	P43B0030A4	32		
		5	20	1	230				L30P4JH	35-3/4	20	P43B0050A2	70	SMC-CR5021	8
		5	20	3	230				L30P4JH	35-3/4	20	P43B0050A3	55		
		5	20	3	460				L30P4JH	35-3/4	20	P43B0050A4	55		
		7-1/2	28	3	230				L30P4KH	50	27	P43B0075A3	70		
		7-1/2	28	3	460				L30P4KH	50	27	P43B0075A4	70		
		10	38	3	460				L30P4LH	65-1/2	35	P43B0100A4	70		

*Length and Weight are approximate.

**For 10 GPM, 15 GPM and 20 GPM discharge is 1-1/4" NPT.

***For 30 GPM and 50 GPM discharge is 2" NPT.

NOTE: On 2 HP and larger – Pump, Motor, Control Box or Magnetic Starter must be ordered separately.

†Check Valve not included on 5 HP, 7-1/2 HP and 10 HP models. Check Valve not included on 50 GPM models.

TrimLine™ version maximum outside diameter is 3-3/4". Standard version maximum outside diameter on all models is 3-7/8".

HS Series Signature 2000®

Stainless Steel

ORDERING INFORMATION

GPM	MOTOR TYPE	HP	STGS.	PH	VOLT	PUMP END			MOTOR		CONTROL BOX	
						CATALOG NUMBER	LENGTH INCHES*	WEIGHT POUNDS*	CATALOG NUMBER	WEIGHT POUNDS*	CATALOG NUMBER	WEIGHT POUNDS*
50***	2 WIRE	1-1/2	4	1	230	L50P4FH	15-1/4	10	P42B0015A2	29		
		1-1/2	4	1	230	L50P4FH	15-1/4	10	P43B0015A2	27	SMC-CR1521	7
	3 WIRE	1-1/2	4	3	230	L50P4FH	15-1/4	10	P43B0015A3	23		
		1-1/2	4	3	460	L50P4FH	15-1/4	10	P43B0015A4	23		
		2	6	1	230	L50P4GH	19-1/4	12	P43B0020A2	31	SMC-CR2021	7
		2	6	3	230	L50P4GH	19-1/4	12	P43B0020A3	27		
		2	6	3	460	L50P4GH	19-1/4	12	P43B0020A4	27		
		3	8	1	230	L50P4HH	23-1/4	15	P43B0030A2	40	SMC-CR3021	7
		3	8	3	230	L50P4HH	23-1/4	15	P43B0030A3	32		
		3	8	3	460	L50P4HH	23-1/4	15	P43B0030A4	32		
		5	13	1	230	L50P4JH	33-1/2	20	P43B0050A2	70	SMC-CR5021	8
		5	13	3	230	L50P4JH	33-1/2	20	P43B0050A3	55		
		5	13	3	460	L50P4JH	33-1/2	20	P43B0050A4	55		
		7-1/2	20	3	230	L50P4KH	47-1/2	25	P43B0075A3	70		
		7-1/2	20	3	460	L50P4KH	47-1/2	25	P43B0075A4	70		
		10	25	3	460	L50P4LH	57-3/4	35	P43B0100A4	70		

*Length and Weight are approximate.

**For 10 GPM, 15 GPM and 20 GPM discharge is 1-1/4" NPT.

***For 30 GPM and 50 GPM discharge is 2" NPT.

NOTE: Pump, Motor, Control Box or Magnetic Starter must be ordered separately.
Check Valve not included on 50 GPM models.

HS Series Signature 2000[®]

Stainless Steel

OUTLINE DIMENSIONS: 10, 15 AND 20 GPM

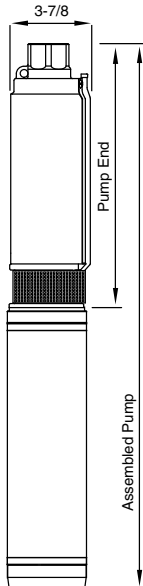

DISCHARGE	
10 GPM	1-1/4" NPT
15 GPM	1-1/4" NPT
20 GPM	1-1/4" NPT

For lengths, refer to Ordering Information tables.
Dimensions (in inches) are for estimating purposes only.

OUTLINE DIMENSIONS: 30 AND 50 GPM

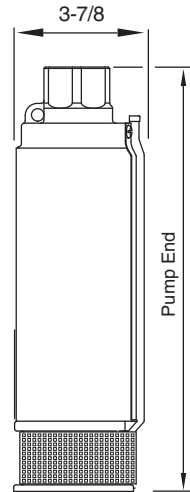

DISCHARGE	
30 GPM	2" NPT
50 GPM	2" NPT

Pump diameter is 3-7/8".
For lengths, refer to Ordering Information tables.
Dimensions (in inches) are for estimating purposes only.

PUMP PERFORMANCE: 10 GPM

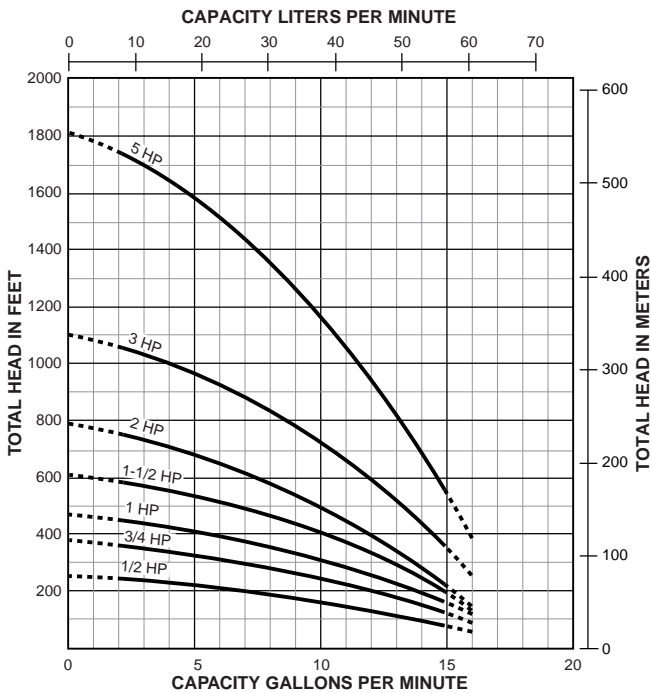

PUMP PERFORMANCE: 15 GPM

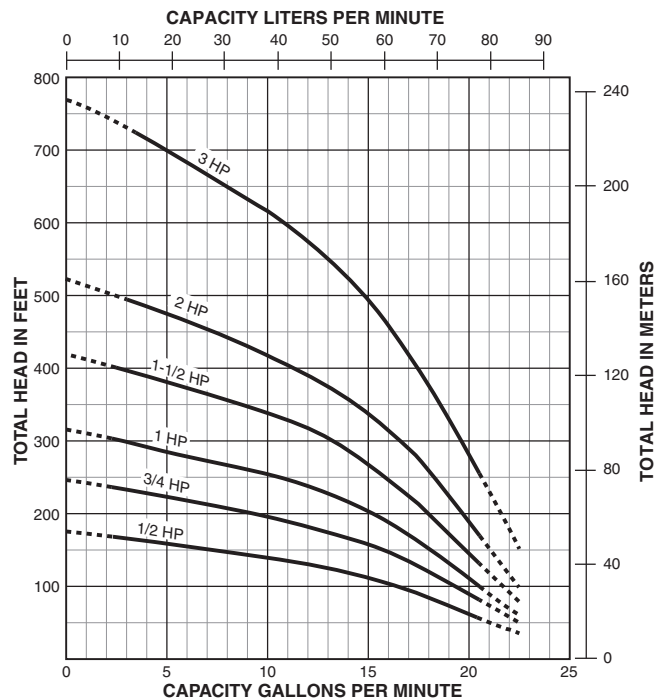

Tested and rated in accordance with Water Systems Council Standards.

NOTE: Pumps installed with a Pro-Source[®] tank require a 100 PSI relief valve. Pumps installed with a conventional tank require a 75 PSI relief valve. Relief valve must be capable of relieving entire flow of pump at relief pressure.

HS Series Signature 2000®

Stainless Steel

PUMP PERFORMANCE: 20 GPM

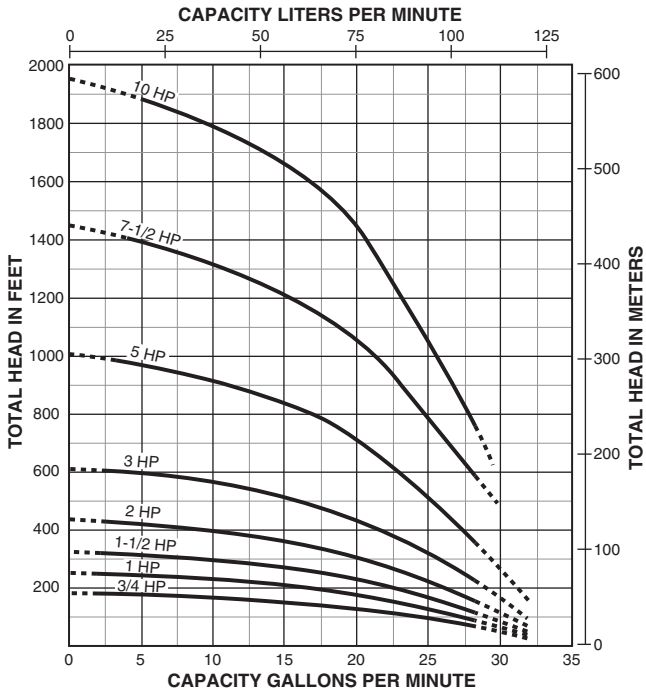

PUMP PERFORMANCE: 30 GPM

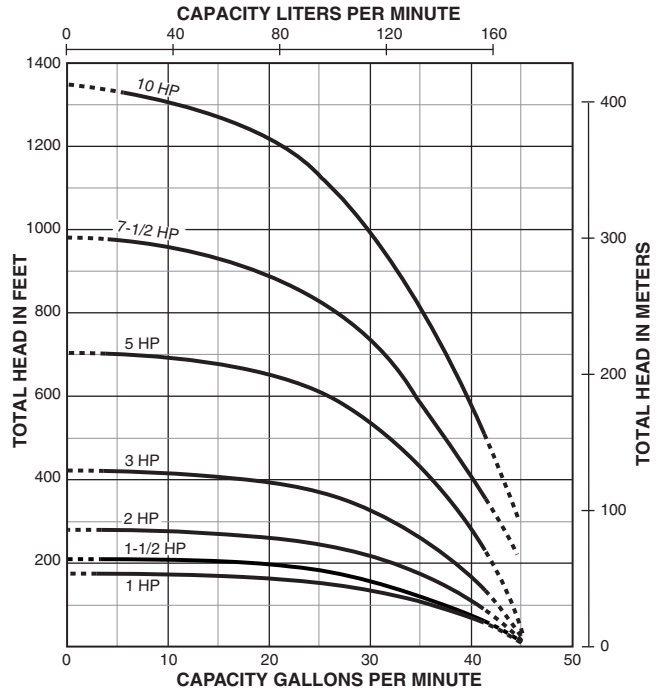

PUMP PERFORMANCE: 50 GPM

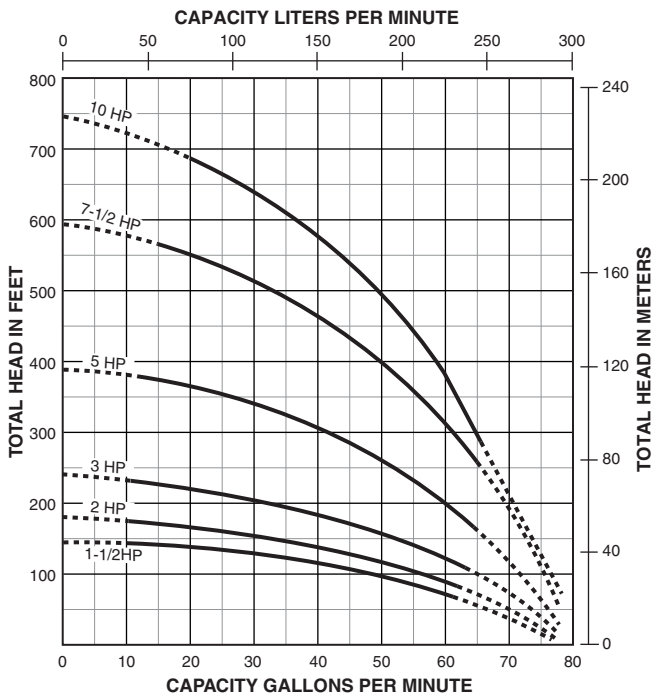

HS Series Signature 2000®

Stainless Steel

15 GALLONS PER MINUTE		PUMP PERFORMANCE (CAPACITY IN GALLONS PER MINUTE)																				SHUT-OFF HEAD					
HP	PSI	PUMPING DEPTH IN FEET																				FEET	PSI				
		20	40	60	80	100	125	150	175	200	250	300	350	400	450	500	550	600	650	700	750			800			
1/2	0	—	—	20.0	18.7	16.9	13.1	7.4															175	76			
	20	19.7	18.3	16.3	13.0	8.8																					
	30	18.0	15.6	12.4	7.9	2.0																					
	40	15.2	11.9	7.0																							
	50	11.2	5.8																								
	60	4.8																									
3/4	0	—	—	21.2	20.2	19.3	17.8	16.0	13.2	9.6													245	106			
	20	20.9	19.9	19.0	17.7	16.4	13.7	10.0	4.9																		
	30	19.8	18.8	17.6	16.1	14.0	10.7	5.5																			
	40	18.6	17.5	15.9	13.5	10.9	6.0																				
	50	17.2	15.4	13.1	10.0	6.4																					
	60	15.0	12.7	9.7	5.5																						
1	0	—	—	—	—	20.4	19.4	18.4	17.2	15.5	10.3	2.7											318	138			
	20	—	20.9	20.2	19.3	18.7	17.5	15.8	13.4	10.9	3.2																
	30	20.8	20.0	19.1	18.5	17.6	16.0	13.7	11.1	7.5																	
	40	19.8	19.0	18.3	17.4	16.2	13.9	11.3	8.1	3.7																	
	50	18.9	18.2	17.1	15.8	14.0	11.4	8.2	4.0	0																	
	60	18.0	17.0	15.6	13.7	11.7	8.4	4.4																			
1-1/2	0	—	—	—	—	—	20.4	19.9	19.3	18.4	16.4	13.1	8.3	2.8									420	182			
	20	—	—	21.2	20.5	20.0	19.3	18.6	17.6	16.5	13.5	9.1	3.2														
	30	—	21.1	20.3	19.9	19.3	18.7	17.7	16.6	15.4	11.7	6.3															
	40	21.0	20.2	19.8	19.2	18.7	17.9	16.7	15.5	13.7	9.4	3.6															
	50	20.2	19.7	19.2	18.6	18.0	16.8	15.6	13.8	11.9	6.7																
	60	19.6	19.0	18.5	17.7	16.9	15.7	13.9	12.0	9.7	3.8																
2	0	—	—	—	—	—	—	20.7	20.2	19.6	18.3	16.9	14.4	11.6	7.4	2.7							525	227			
	20	—	—	—	21.2	20.9	20.2	19.7	19.1	18.4	17.0	14.7	11.8	7.8	3.2												
	30	—	—	21.2	20.8	20.3	19.7	19.1	18.5	17.9	16.1	13.5	10.2	5.5													
	40	—	21.1	20.6	20.2	19.8	19.2	18.6	17.9	17.1	14.9	12.0	8.1	3.4													
	50	21.1	20.6	20.1	19.7	19.2	18.6	17.9	17.1	16.2	13.6	10.8	6.0														
	60	20.5	20.1	19.6	19.1	18.7	18.0	17.2	16.2	15.1	12.2	8.6	3.7														
3	0	—	—	—	—	—	—	—	—	21.0	20.2	19.5	18.7	17.8	16.6	15.0	13.0	10.8	8.0	4.9	1.6			770	333		
	20	—	—	—	—	—	—	21.1	20.8	20.3	19.5	18.8	17.9	16.7	15.1	13.2	11.1	8.3	5.2	1.9							
	30	—	—	—	—	—	21.2	20.8	20.3	19.9	19.2	18.3	17.4	16.1	14.3	12.2	10.4	7.0	3.5	3.6							
	40	—	—	—	21.6	21.2	20.9	20.4	19.9	19.6	18.8	18.0	16.8	15.2	13.4	11.2	8.4	5.4	2.1								
	50	—	—	21.6	21.1	20.9	20.4	20.0	19.7	19.2	18.4	17.5	16.2	14.4	12.3	10.5	7.1	3.8									
	60	—	21.4	21.1	20.8	20.5	20.0	19.7	19.3	18.9	18.0	16.9	15.3	13.5	11.4	8.8	5.5										

CAUTION: DO NOT use pump at flow rates indicated by the symbol '—'. To do so can cause premature failure of unit. Pump warranty void when failure occurs under these conditions.

Tested and rated in accordance with Water Systems Council Standards.

NOTE: Pumps installed with a Pro-Source® tank require a 100 PSI relief valve. Pumps installed with a conventional tank require a 75 PSI relief valve. Relief valve must be capable of relieving entire flow of pump at relief pressure.

HS Series Signature 2000®

Stainless Steel

20 GALLONS PER MINUTE		PUMP PERFORMANCE (CAPACITY IN GALLONS PER MINUTE)																				SHUT-OFF HEAD										
HP	PSI	PUMPING DEPTH IN FEET																				FEET	PSI									
		20	40	60	80	100	125	150	175	200	250	300	350	400	450	500	550	600	650	700	750			800	850	900	950	1000				
3/4	0	—	—	29.2	26.9	23.5	19.0	13.7																			180	78				
	20	—	25.8	22.5	18.5	14.5	3.4																									
	30	25.2	22.0	18.3	13.9	4.5																										
	40	21.3	17.6	13.0	3.0																											
	50	17.2	11.4																													
	60	10.2																														
1	0	—	—	—	—	25.3	22.4	18.8	15.5																		251	109				
	20	—	—	27.4	25.1	22.8	19.5	16.1	10.1																							
	30	—	27.2	24.9	22.5	19.8	16.5	10.6																								
	40	27.0	24.5	22.0	19.4	16.8	11.6	2.6																								
	50	24.2	21.5	19.0	16.3	12.5	3.3																									
	60	21.3	18.6	16.0	11.1	3.7																										
1-1/2	0	—	—	—	—	—	26.4	24.0	21.6	16.4	5.4																323	140				
	20	—	—	—	—	26.8	24.4	22.0	19.5	16.8	6.8																					
	30	—	—	—	—	26.5	24.7	22.2	19.6	17.1	13.9																					
	40	—	27.8	26.2	24.3	22.3	19.8	17.3	14.2	8.0																						
	50	27.5	26.0	24.1	22.1	20.0	17.5	14.5	8.3																							
	60	25.6	23.9	21.9	19.8	17.5	14.8	9.1	2.2																							
2	0	—	—	—	—	—	27.3	26.0	23.2	20.2	16.2	8.5															420	275				
	20	—	—	—	—	—	26.1	24.9	23.4	20.6	16.7	9.5																				
	30	—	—	—	—	27.6	26.2	25.0	23.5	22.1	19.1	13.8	4.8																			
	40	—	—	—	—	27.5	26.4	25.1	23.7	22.2	20.8	17.2	10.1																			
	50	—	—	27.2	26.1	25.1	23.8	22.3	20.9	19.3	14.0	5.7																				
	60	—	27.1	26.0	25.0	23.9	22.4	21.0	19.4	17.3	10.8																					
3	0	—	—	—	—	—	—	—	—	27.2	25.3	23.5	21.3	19.1	16.0	11.3	3.6										605	349				
	20	—	—	—	—	—	—	—	—	27.3	25.4	23.6	21.6	19.3	16.1	12.0	5.0															
	30	—	—	—	—	—	—	—	—	27.4	26.6	24.8	22.7	20.6	18.1	14.5	9.0															
	40	—	—	—	—	—	—	—	—	27.5	26.7	25.5	23.8	21.7	19.6	16.8	12.5	5.3														
	50	—	—	—	—	—	—	—	—	27.6	26.7	25.6	24.9	22.8	20.8	18.5	15.0	9.5														
	60	—	—	—	—	—	—	—	—	27.7	26.8	25.7	24.9	23.9	21.8	19.8	16.9	12.7	5.6													
5	0	—	—	—	—	—	—	—	—	—	—	—	27.5	26.5	25.2	24.0	22.8	21.5	20.2	18.9	17.0	14.3	11.0	6.8		1005	476					
	20	—	—	—	—	—	—	—	—	—	—	—	27.6	26.6	25.3	24.1	22.9	21.6	20.3	19.0	17.3	14.0	11.2	7.3								
	30	—	—	—	—	—	—	—	—	—	—	—	27.1	26.0	24.9	23.5	22.2	21.0	19.9	18.2	16.2	13.3	9.5	5.2								
	40	—	—	—	—	—	—	—	—	—	—	—	27.7	26.7	25.4	24.2	22.9	21.7	20.4	19.1	17.5	14.4	11.5	7.7	3.1							
	50	—	—	—	—	—	—	—	—	—	—	—	27.2	26.0	25.0	23.6	22.3	21.1	20.0	18.4	16.3	13.5	9.9	5.7								
	60	—	—	—	—	—	—	—	—	—	27.8	26.8	25.5	24.3	23.0	21.8	20.5	19.2	17.7	14.9	12.0	8.0	3.7									
7-1/2	0	—	—	—	—	—	—	—	—	—	—	—	—	—	27.3	25.7	24.3	23.1	21.5	19.9	16.4	11.3	4.1		1450	628						
	20	—	—	—	—	—	—	—	—	—	—	—	—	—	26.7	25.3	23.7	22.3	20.8	18.9	14.7	8.5										
	30	—	—	—	—	—	—	—	—	—	—	—	—	—	26.5	25.1	23.5	22.1	20.6	18.3	13.4	7.0										
	40	—	—	—	—	—	—	—	—	—	—	—	—	—	27.5	26.3	24.7	23.3	21.7	20.2	17.3	12.1	5.3									
	50	—	—	—	—	—	—	—	—	—	—	—	—	—	27.3	25.7	24.5	22.7	21.3	19.7	16.0	10.6	3.6									
	60	—	—	—	—	—	—	—	—	—	—	—	—	—	26.9	25.5	24.3	22.5	21.0	19.3	15.1	9.5										
10	0	—	—	—	—	—	—	—	—	—	—	—	—	—	—	—	—	—	—	—	—	—	—	—	—	1950	844					
	20	—	—	—	—	—	—	—	—	—	—	—	—	—	26.8	25.7	24.7	23.7	22.6	21.6	20.7	19.5	17.1									
	30	—	—	—	—	—	—	—	—	—	—	—	—	—	27.5	26.4	25.3	24.4	23.3	22.1	21.3	20.1	18.5	16.0								
	40	—	—	—	—	—	—	—	—	—	—	—	—	—	27.3	26.2	25.0	24.1	23.0	21.9	21.0	19.9	18.0	15.0								
	50	—	—	—	—	—	—	—	—	—	—	—	—	—	27.0	25.7	24.9	24.0	22.8	21.7	20.8	19.7	17.6	14.7								
	60	—	—	—	—	—	—	—	—	—	—	—	—	—	27.8	26.7	25.5	24.7	23.6	22.5	21.5	20.6	19.4	17.0	14.0							

CAUTION: DO NOT use pump at flow rates indicated by the symbol '—'. To do so can cause premature failure of unit. Pump warranty void when failure occurs under these conditions. Tested and rated in accordance with Water Systems Council Standards.

NOTE: Pumps installed with a Pro-Source® tank require a 100 PSI relief valve. Pumps installed with a conventional tank require a 75 PSI relief valve. Relief valve must be capable of relieving entire flow of pump at relief pressure.

HS Series Signature 2000®

Stainless Steel

30 GALLONS PER MINUTE										PUMP PERFORMANCE (CAPACITY IN GALLONS PER MINUTE)										SHUT-OFF HEAD					
HP	PSI	PUMPING DEPTH IN FEET																		FEET	PSI				
		20	40	60	80	100	125	150	175	200	250	300	350	400	450	500	550	600	650			700			
1	0	—	42.5	40.9	39.1	36.8	32.5	26.0	8.0												175	76			
	20	40.4	38.8	36.0	32.4	27.7	13.3																		
	30	38.0	35.3	31.7	26.3	14.3																			
	40	35.0	31.4	25.9	12.1																				
	50	30.2	24.0	3.0																					
	60	21.9																							
1-1/2	0	—	—	41.9	39.9	37.5	34.1	30.9	26.9	17.0											210	91			
	20	41.2	39.1	36.5	34.0	31.5	27.8	21.5																	
	30	38.9	36.1	33.8	31.0	27.9	21.8																		
	40	36.0	33.5	30.8	27.7	20.2																			
	50	32.9	30.1	26.8	21.5																				
	60	29.5	25.9	18.1																					
2	0	—	—	—	41.8	40.5	38.8	36.8	34.7	31.6	23.7										280	121			
	20	—	41.3	40.1	38.7	37.1	34.9	32.1	29.0	24.8															
	30	41.2	40.0	38.5	37.0	35.0	32.2	29.1	24.9	15.2															
	40	39.9	38.3	36.6	34.8	32.7	29.8	25.1	16.1																
	50	38.0	36.3	34.5	32.1	30.0	25.3	17.5																	
	60	36.0	34.0	31.9	29.1	26.0	18.0																		
3	0	—	—	—	—	42.7	41.6	40.1	39.6	38.2	35.5	32.0	27.3								420	182			
	20	—	—	42.4	41.5	41.0	39.8	38.5	37.1	35.7	32.1	28.0	18.5												
	30	42.9	42.2	41.3	40.6	39.9	38.7	37.2	35.8	34.2	30.3	24.9	6.0												
	40	42.1	41.2	40.4	39.7	38.8	37.3	35.9	34.5	32.6	28.3	19.9													
	50	41.1	40.3	39.5	38.5	37.4	36.0	34.6	32.7	31.0	25.2	9.5													
	60	40.2	39.3	38.3	37.2	36.1	34.7	32.8	31.0	28.5	20.5														
5	0	—	—	—	—	—	—	—	42.6	42.0	40.7	39.2	38.0	36.0	34.2	31.9	29.2	26.0	20.0		705	305			
	20	—	—	—	—	—	42.7	42.0	41.3	40.8	39.3	38.2	36.2	34.4	32.4	30.0	26.1	21.5							
	30	—	—	—	—	42.8	42.1	41.4	40.8	40.1	38.7	37.0	35.1	33.1	31.1	26.0	24.1	16.0							
	40	—	—	—	—	42.1	41.5	40.9	40.2	39.3	37.9	36.1	34.3	32.0	29.4	26.2	20.4								
	50	—	—	42.6	42.0	41.5	41.2	40.2	39.5	38.8	37.1	35.4	33.2	31.2	28.8	24.5	16.0								
	60	—	42.5	42.0	41.4	41.1	40.3	39.8	38.9	38.1	36.2	34.2	32.1	30.0	26.7	22.0									
HP	PSI	PUMPING DEPTH IN FEET														SHUT-OFF HEAD									
		200	300	400	500	600	700	800	900	1000	1100	1200	1300	1400	FEET	PSI									
7-1/2	0	—	—	—	40.4	37.6	34.8	32.0	28.1	20.0											975	422			
	20	—	42.0	39.3	36.5	33.8	30.5	25.5	13.8																
	30	—	41.3	38.6	35.8	33.1	29.8	23.3	6.5																
	40	—	40.7	38.1	35.6	32.6	29.3	21.7																	
	50	42.7	40.1	37.3	34.6	31.7	27.4	19.3																	
	60	42.0	39.4	36.5	33.7	30.7	25.1	13.9																	
10	0	—	—	—	41.3	39.5	37.3	35.1	33.1	30.4	27.1	22.5	11.9								1345	582			
	20	—	—	42.3	40.5	38.6	36.4	34.5	31.8	29.2	25.3	18.7													
	30	—	—	42.0	40.1	43.0	35.7	33.7	31.3	28.4	24.2	16.3													
	40	—	—	41.6	39.7	37.7	35.5	33.5	30.9	27.7	23.4	14.4													
	50	—	42.7	41.0	39.3	37.1	34.9	32.8	30.2	26.7	21.7	7.7													
	60	—	42.3	40.6	38.7	36.5	34.5	32.3	29.5	25.7	20.1	5.0													

CAUTION: DO NOT use pump at flow rates indicated by the symbol '—'. To do so can cause premature failure of unit. Pump warranty void when failure occurs under these conditions. Tested and rated in accordance with Water Systems Council Standards.

NOTE: Pumps installed with a Pro-Source® tank require a 100 PSI relief valve. Pumps installed with a conventional tank require a 75 PSI relief valve. Relief valve must be capable of relieving entire flow of pump at relief pressure.

HS Series Signature 2000®

Stainless Steel

50 GALLONS PER MINUTE		PUMP PERFORMANCE (CAPACITY IN GALLONS PER MINUTE)															SHUT-OFF HEAD		
HP	PSI	PUMPING DEPTH IN FEET															FEET	PSI	
		20	40	60	80	100	125	150	175	200	250	300	350	450	550	650			700
1-1/2	0	—	—	—	58.2	49.3	33.5											145	63
	20	—	55.9	46.5	32.5														
	30	54.8	45.0	30.0															
	40	43.3	26.9																
	50	21.9																	
	60																		
2	0	—	—	—	63.3	57.0	47.8	33.9										180	78
	20	—	62.2	55.1	46.8	37.1	13.0												
	30	61.1	53.6	46.0	34.3	14.1													
	40	52.8	45.0	32.5	11.0														
	50	42.7	27.9																
	60	25.2																	
3	0	—	—	—	—	64.5	59.4	52.5	45.0	33.8								235	102
	20	—	—	63.7	59.0	53.5	46.5	36.2	18.2										
	30	—	62.9	58.1	53.0	47.0	37.0	20.5											
	40	62.5	57.6	52.0	46.2	38.8	22.1												
	50	56.5	51.0	44.7	36.2	22.8													
	60	50.0	43.7	34.0	20.5														
5	0	—	—	—	—	—	—	65.9	63.2	59.9	51.9	41.9	22.5					385	166
	20	—	—	—	—	—	63.5	60.8	56.1	52.4	42.5	24.9							
	30	—	—	—	—	63.8	60.9	56.9	53.0	47.9	35.5	12.9							
	40	—	—	65.5	63.2	61.0	57.0	53.2	48.0	43.5	27.0								
	50	—	65.1	63.0	60.8	57.1	53.3	48.1	43.6	36.4	14.2								
	60	64.9	62.4	60.0	56.9	53.7	48.7	44.1	37.5	28.0									
7-1/2	0	—	—	—	—	—	—	—	—	—	66.0	61.0	55.3	43.1	20.0			595	257
	20	—	—	—	—	—	—	—	—	64.8	61.1	56.0	50.0	34.9					
	30	—	—	—	—	—	—	—	64.9	63.3	58.7	53.2	47.2	28.8					
	40	—	—	—	—	—	—	65.0	63.6	61.7	56.2	50.9	44.1	22.0					
	50	—	—	—	—	—	65.1	63.7	61.8	58.9	53.9	47.5	41.0	13.2					
	60	—	—	—	—	65.2	63.8	61.9	59.0	56.5	51.1	44.9	36.0						
10	0	—	—	—	—	—	—	—	—	—	65.0	62.1	54.2	44.7	29.0	15.2		745	322
	20	—	—	—	—	—	—	—	—	65.5	62.5	59.1	50.1	39.2	17.1				
	30	—	—	—	—	—	—	—	—	66.9	64.1	61.2	56.9	47.5	35.0	10.5			
	40	—	—	—	—	—	—	—	67.0	65.8	63.0	59.3	54.9	45.2	30.5				
	50	—	—	—	—	—	—	67.1	65.9	64.2	61.5	57.2	53.0	42.9	25.0				
	60	—	—	—	—	—	67.2	66.0	64.3	63.2	59.9	55.0	51.0	40.6	19.7				

CAUTION: DO NOT use pump at flow rates indicated by the symbol '—'. To do so can cause premature failure of unit. Pump warranty void when failure occurs under these conditions.

Tested and rated in accordance with Water Systems Council Standards.

NOTE: Pumps installed with a Pro-Source® tank require a 100 PSI relief valve. Pumps installed with a conventional tank require a 75 PSI relief valve. Relief valve must be capable of relieving entire flow of pump at relief pressure.

JP Series Signature 2000[®] 5 and 7 gpm TrimLine[™]

Composite



POWERED BY
PENTEK[®]



Precision-engineered, corrosion-resistant Signature 2000[®] Composite Pumps in 5 and 7 GPM deliver efficient, dependable performance even in rough, aggressive water. Heads to over 850 feet and capacities to 10 GPM. Built to deliver long-term, trouble-free service.

These pumps feature the proven SignaSeal[™] staging system. Floating stack design resists sand and reduces sand locking.

The 5 and 7 GPM models are the smaller 3-3/4" diameter TrimLine.

APPLICATIONS

Water systems...for residential, industrial, commercial, multiple housing and farm use.

SPECIFICATIONS

Shell: Stainless steel

Discharge: Fiberglass-reinforced thermoplastic

Discharge Bearing: Nylatron[®]

Intermediate Bearing: (On larger units) polycarbonate, nitrile rubber and stainless steel

Impellers: Acetal

Diffusers: Polycarbonate

Suction Caps: Polycarbonate with stainless steel insert

Thrust Pads: Proprietary spec.

Shaft and Coupling : Stainless steel

Intake: Fiberglass-reinforced thermoplastic

Intake Screen: Polypropylene

Cable Guard: Stainless steel

Agency Listings: CSA

Check Valve: Acetal

FEATURES

Proven Staging System:

Our proven SignaSeal staging system incorporates a harder-than-sand ceramic wear surface that when incorporated with our floating impeller design, greatly reduces problems with abrasives, sand lock-up and running dry.

Discharge: Corrosion-resistant fiberglass-reinforced thermoplastic for durability in aggressive water. Large octagon wrench area for ease of installation.

Discharge Bearing: Exclusive self-lubricating Nylatron bearing resists wear from sand.

Intake: Corrosion-resistant fiberglass-reinforced thermoplastic for durability in aggressive water.

Shaft: Positive drive from 7/16" hexagonal heavy-duty 300 grade stainless steel.

Coupling: Stainless steel press fit to pump shaft. Couples to all standard NEMA motors.

Shell: Heavy-walled corrosion-resistant stainless steel. Threaded for easy servicing.

Hardware: All screws, washers and nuts are corrosion-resistant 300 grade stainless steel.

Check Valve: Durable internal poppet-type check valve.

Cable Guard: Corrosion-resistant stainless steel guard protects motor leads. Tapered ends prevent pump from catching on well.

Intake Screen: Corrosion-proof polypropylene.

Pentek[®] XE Series[™] Motor: 2 and 3 wire NEMA standard all stainless construction water-filled motors.

Nylatron[®] is a registered trademark of Polymer Corp.
All other brand or product names are trademarks or registered trademarks of Pentair Ltd.

JP Series Signature 2000[®] 5 and 7 gpm TrimLine[™] Composite

ORDERING INFORMATION

GPM	MOTOR TYPE	HP	STGS.	PH	VOLT	ASSEMBLED PUMP			PUMP END			MOTOR		CONTROL BOX	
						CATALOG NUMBER	LENGTH INCHES*	WEIGHT POUNDS*	CATALOG NUMBER	LENGTH INCHES*	WEIGHT POUNDS*	CATALOG NUMBER	WEIGHT POUNDS*	CATALOG NUMBER	WEIGHT POUNDS*
5	2 WIRE	1/2	13	1	115	S5P4JP05121	27-1/2	29	L5P4CJL	18	12	P42B0005A1	19		
		1/2	13	1	230	S5P4JP05221	27-1/2	29	L5P4CJL	18	12	P42B0005A2	19		
		3/4	18	1	230	S5P4JP07221	32-3/4	34	L5P4DJL	22	15	P42B0007A2	23		
		1	22	1	230	S5P4JP10221	37	38	L5P4EJL	25-1/4	17	P42B0010A2	25		
		1-1/2	30	1	230	S5P4JP15221	47	45	L5P4FJL	32	21	P42B0015A2	29		
	3 WIRE	1/2	13	1	115	S5P4JP05131	27-1/2	29	L5P4CJL	18	12	P43B0005A1	19	SMC-IR0511	4
		1/2	13	1	230	S5P4JP05231	27-1/2	29	L5P4CJL	18	12	P43B0005A2	18	SMC-CR0521	4
		3/4	18	1	230	S5P4JP07231	32-3/4	24	L5P4DJL	22	15	P43B0007A2	21	SMC-CR0721	4
		1	22	1	230	S5P4JP10231	37	38	L5P4EJL	25-1/4	17	P43B0010A2	23	SMC-CR1021	4
		1	22	3	230				L5P4EJL	25-1/4	17	P43B0010A3	23		
		1	22	3	460				L5P4EJL	25-1/4	17	P43B0010A4	23		
		1-1/2	30	1	230	S5P4JP15231	45-1/2	45	L5P4FJL	32	21	P43B0015A2	27	SMC-CR1521	7
		1-1/2	30	3	230				L5P4FJL	32	21	P43B0015A3	23		
		1-1/2	30	3	460				L5P4FJL	32	21	P43B0015A4	23		
7	2 WIRE	1/2	10	1	115	S7P4JP05121	25-1/2	27	L7P4CJL	16	12	P42B0005A1	19		
		1/2	10	1	230	S7P4JP05221	25-1/2	27	L7P4CJL	16	12	P42B0005A2	19		
		3/4	13	1	230	S7P4JP07221	29	32	L7P4DJL	18-1/2	15	P42B0007A2	23		
		1	17	1	230	S7P4JP10221	33-3/4	37	L7P4EJL	22	17	P42B0010A2	25		
		1-1/2	22	1	230	S7P4JP15221	42-1/2	47	L7P4FJL	27-1/4	21	P42B0015A2	29		
	3 WIRE	1/2	10	1	115	S7P4JP05131	25-1/2	27	L7P4CJL	16	12	P43B0005A1	19	SMC-IR0511	4
		1/2	10	1	230	S7P4JP05231	25-1/2	27	L7P4CJL	16	12	P43B0005A2	18	SMC-CR0521	4
		3/4	13	1	230	S7P4JP07231	29	32	L7P4DJL	18-1/2	15	P43B0007A2	21	SMC-CR0721	4
		1	17	1	230	S7P4JP10231	33-3/4	37	L7P4EJL	22	17	P43B0010A2	23	SMC-CR1021	4
		1	17	3	230				L7P4EJL	22	17	P43B0010A3	23		
		1	17	3	460				L7P4EJL	22	17	P43B0010A4	23		
		1-1/2	22	1	230	S7P4JP15231	41	44	L7P4FJL	27-1/4	21	P43B0015A2	27	SMC-CR1521	7
		1-1/2	22	3	230				L7P4FJL	27-1/4	21	P43B0015A3	23		
		1-1/2	22	3	460				L7P4FJL	27-1/4	21	P43B0015A4	23		

*Length and Weight are approximate.

TrimLine[™] version maximum outside diameter is 3-3/4". Standard version maximum outside diameter is 3-7/8".

NOTE: Motor, Control Box or Magnetic Starter must be ordered separately. Discharge NPT is 1-1/4".

JP Series Signature 2000[®] 5 and 7 gpm TrimLine[™] Composite

OUTLINE DIMENSIONS

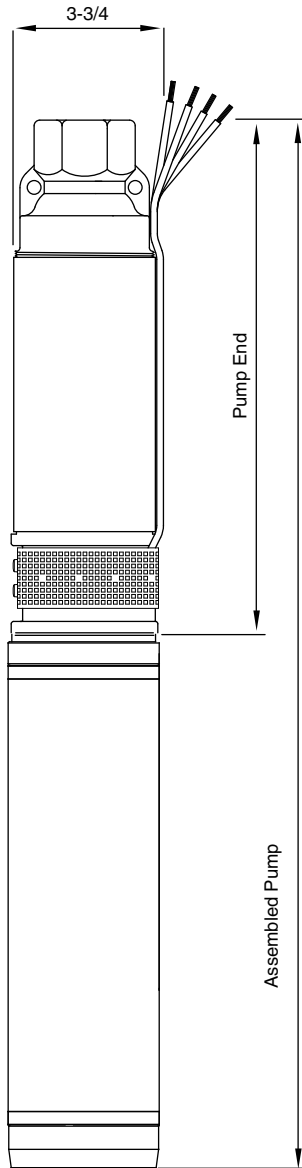

DISCHARGE	
5 GPM	1-1/4" NPT
7 GPM	1-1/4" NPT

For dimensions, refer to Ordering Information table.
 Dimensions (in inches) are for estimating purposes only.

PUMP PERFORMANCE: 5 GPM

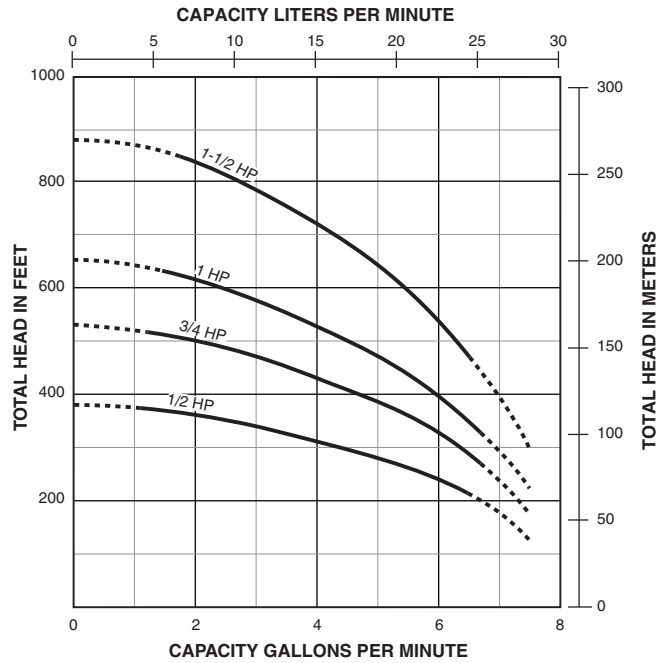

PUMP PERFORMANCE: 7 GPM

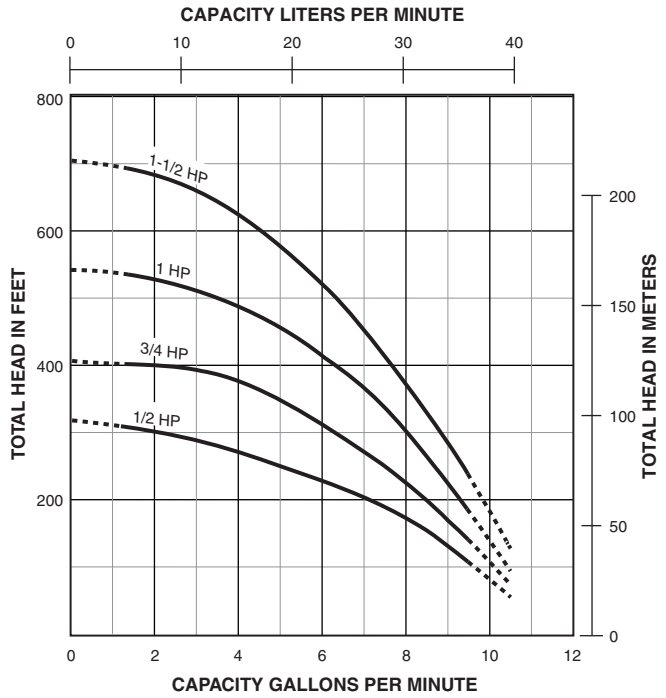

Tested and rated in accordance with Water Systems Council Standards.
 NOTE: Pumps installed with a Pro-Source[®] tank require a 100 PSI relief valve. Pumps installed with a conventional tank require a 75 PSI relief valve.
 Relief valve must be capable of relieving entire flow of pump at relief pressure.

JP Series Signature 2000®

Composite



POWERED BY
PENTEK®



Precision-engineered, corrosion-resistant Signature 2000® Composite Pumps in 10, 15, 20 and 30 GPM deliver efficient, dependable performance even in rough, aggressive water. Heads to over 650 feet and capacities to 45 GPM. Built to deliver long-term, trouble-free service.

These pumps feature the proven SignaSeal™ staging system. Floating impeller design resists sand and reduces sand locking.

APPLICATIONS

Water systems...for residential, industrial, commercial, multiple housing and farm use.

SPECIFICATIONS

Shell: Stainless steel

Diameter: 3-7/8"

Discharge: Fiberglass-reinforced thermoplastic

Discharge Bearing: Nylatron®

Intermediate Bearing: (On larger units) polycarbonate, nitrile rubber and stainless steel

Impellers: Acetal

Diffusers: Polycarbonate

Suction Caps: Polycarbonate with stainless steel insert

Thrust Pads: Proprietary spec.

Shaft and Coupling: Stainless steel

Intake: Fiberglass-reinforced thermoplastic

Intake Screen: Polypropylene

Cable Guard: Stainless steel

Check Valve: Acetal

Agency Listings: CSA

FEATURES

Proven Staging System: Our proven SignaSeal staging system incorporates a harder-than-sand ceramic wear surface that when incorporated with our floating impeller design, greatly reduces problems with abrasives, sand lock-up and running dry.

Discharge: Corrosion-resistant fiberglass-reinforced thermoplastic for durability in aggressive water. Large octagon wrench area for ease of installation.

Discharge Bearing: Exclusive self-lubricating Nylatron bearing resists wear from sand.

Intake: Corrosion-resistant fiberglass-reinforced thermoplastic for durability in aggressive water.

Shaft: Positive drive from 7/16" hexagonal heavy-duty 300 grade stainless steel.

Coupling: Stainless steel press fit to pump shaft. Couples to all standard NEMA motors.

Shell: Heavy-walled corrosion-resistant stainless steel. Threaded for easy servicing.

Hardware: All screws, washers and nuts are corrosion-resistant 300 grade stainless steel.

Check Valve: Durable internal poppet-type check valve.

Cable Guard: Corrosion-resistant stainless steel guard protects motor leads. Tapered ends prevent pump from catching on well.

Intake Screen: Corrosion-proof polypropylene.

Pentek® XE Series™ Motor: 2 and 3 wire NEMA standard all stainless construction water-filled motors.

Nylatron® is a registered trademark of Polymer Corp.
All other brand or product names are trademarks or registered trademarks of Pentair Ltd.

JP Series Signature 2000®

Composite

ORDERING INFORMATION

GPM	MOTOR TYPE	HP	STGS.	PH	VOLT	ASSEMBLED PUMP			PUMP END			MOTOR		CONTROL BOX	
						CATALOG NUMBER	LENGTH INCHES*	WEIGHT POUNDS*	CATALOG NUMBER	LENGTH INCHES*	WEIGHT POUNDS*	CATALOG NUMBER	WEIGHT POUNDS*	CATALOG NUMBER	WEIGHT POUNDS*
10**	2 WIRE	1/2	7	1	115	S10P4JP05121	22-3/4	27-1/2	L10P4CJ	12-3/4	9	P42B0005A1	19		
		1/2	7	1	230	S10P4JP05221	22-3/4	27-1/2	L10P4CJ	12-3/4	9	P42B0005A2	19		
		3/4	10	1	230	S10P4JP07221	25-3/4	30-1/2	L10P4DJ	14-1/2	10	P42B0007A2	23		
		1	13	1	230	S10P4JP10221	28-3/4	34-1/2	L10P4EJ	16	10-3/4	P42B0010A2	25		
		1-1/2	17	1	230	S10P4JP15221	34-3/4	41-1/2	L10P4FJ	19-3/4	12-1/2	P42B0015A2	29		
	3 WIRE	1/2	7	1	115	S10P4JP05131	22-3/4	27-1/2	L10P4CJ	12-3/4	9	P43B0005A1	19	SMC-IR0511	4
		1/2	7	1	230	S10P4JP05231	22-3/4	27-1/2	L10P4CJ	12-3/4	9	P43B0005A2	18	SMC-CR0521	4
		3/4	10	1	230	S10P4JP07231	25-3/4	30-1/2	L10P4DJ	14-1/2	10	P43B0007A2	21	SMC-CR0721	4
		1	13	1	230	S10P4JP10231	28-3/4	34-1/2	L10P4EJ	16-1/4	10-3/4	P43B0010A2	23	SMC-CR1021	4
		1	13	3	230				L10P4EJ	15-1/2	10-1/4	P43B0010A3	23		
		1	13	3	460				L10P4EJ	15-1/2	10-1/4	P43B0010A4	23		
		1-1/2	17	1	230	S10P4JP15231	33-1/2	41-1/2	L10P4FJ	19-3/4	12-1/2	P43B0015A2	27	SMC-CR1521	7
		1-1/2	17	3	230				L10P4FJ	19-3/4	12-1/2	P43B0015A3	23		
		1-1/2	17	3	460				L10P4FJ	19-3/4	12-1/2	P43B0015A4	23		
15**	2 WIRE	1/2	5	1	115	S15P4JP05121	22-1/4	27	L15P4CJ	12-1/4	9	P42B0005A1	19		
		1/2	5	1	230	S15P4JP05221	22-1/4	27	L15P4CJ	12-1/4	9	P42B0005A2	19		
		3/4	7	1	230	S15P4JP07221	25-3/4	31	L15P4DJ	14-1/2	10	P42B0007A2	23		
		1	9	1	230	S15P4JP10221	29-1/4	35	L15P4EJ	16-3/4	11	P42B0010A2	25		
		1-1/2	12	1	230	S15P4JP15221	35-1/4	43	L15P4FJ	20-1/4	13	P42B0015A2	29		
	3 WIRE	1/2	5	1	115	S15P4JP05131	22-1/4	27	L15P4CJ	12-1/4	9	P43B0005A1	19	SMC-IR0511	4
		1/2	5	1	230	S15P4JP05231	22-1/4	27	L15P4CJ	12-1/4	9	P43B0005A2	18	SMC-CR0521	4
		3/4	7	1	230	S15P4JP07231	25-3/4	31	L15P4DJ	14-1/2	10	P43B0007A2	21	SMC-CR0721	4
		1	9	1	230	S15P4JP10231	29-1/4	35	L15P4EJ	16-3/4	11	P43B0010A2	23	SMC-CR1021	4
		1	9	3	230				L15P4EJ	15-1/2	10-1/4	P43B0010A3	23		
		1	9	3	460				L15P4EJ	15-1/2	10-1/4	P43B0010A4	23		
		1-1/2	12	1	230	S15P4JP15231	33-3/4	41	L15P4FJ	20-1/4	13	P43B0015A2	27	SMC-CR1521	7
		1-1/2	12	3	230				L15P4FJ	20-1/4	13	P43B0015A3	23		
		1-1/2	12	3	460				L15P4FJ	20-1/4	13	P43B0015A4	23		
20**	2 WIRE	3/4	5	1	230	S20P4JP07221	23-3/4	30	L20P4DJ	12-1/2	8-1/2	P42B0007A2	23		
		1	7	1	230	S20P4JP10221	27-1/4	34	L20P4EJ	14-3/4	9-3/4	P42B0010A2	25		
		1-1/2	9	1	230	S20P4JP15221	32	39	L20P4FJ	16-3/4	10-3/4	P42B0015A2	29		
		3/4	5	1	230	S20P4JP07231	23-3/4	30	L20P4DJ	12-1/2	8-1/2	P43B0007A2	21	SMC-CR0721	4
	3 WIRE	1	7	1	230	S20P4JP10231	27-1/4	34	L20P4EJ	14-3/4	9-3/4	P43B0010A2	23	SMC-CR1021	4
		1	7	3	230				L20P4EJ	15-1/2	10-1/4	P43B0010A3	23		
		1	7	3	460				L20P4EJ	15-1/2	10-1/4	P43B0010A4	23		
		1-1/2	9	1	230	S20P4JP15231	30-1/2	39	L20P4FJ	16-3/4	10-3/4	P43B0015A2	27	SMC-CR1521	7
		1-1/2	9	3	230				L20P4FJ	16-3/4	10-3/4	P43B0015A3	23		
		1-1/2	9	3	460				L20P4FJ	16-3/4	10-3/4	P43B0015A4	23		
		2	12	1	230				L20P4GJ	20-1/4	12-1/2	P43B0020A2	31	SMC-CR2021	7
		2	12	3	230				L20P4GJ	20-1/4	12-1/2	P43B0020A3	23		
		2	12	3	460				L20P4GJ	20-1/4	12-1/2	P43B0020A4	23		
		30**	2 WIRE	1	5	1	230	S30P4JP10221	26-1/2	35	L30P4EJ	14	10	P42B0010A2	25
1-1/2	6			1	230	S30P4JP15221	30-1/2	39	L30P4FJ	15-1/4	11	P42B0015A2	29		
3 WIRE	1		5	1	230	S30P4JP10231	26-1/2	35	L30P4EJ	14	10	P43B0010A2	23	SMC-CR1021	4
	1		5	3	230				L30P4EJ	15-1/2	10-1/4	P43B0010A3	23		
	1		5	3	460				L30P4EJ	15-1/2	10-1/4	P43B0010A4	23		
	1-1/2		6	1	230	S30P4JP15231	29	39	L30P4FJ	15-1/4	11	P43B0015A2	27	SMC-CR1521	7
	1-1/2		6	3	230				L30P4FJ	15-1/4	11	P43B0015A3	23		
	1-1/2		6	3	460				L30P4FJ	15-1/4	11	P43B0015A4	23		
	2		8	1	230				L30P4GJ	18-1/4	12	P43B0020A2	31	SMC-CR2021	7
	2		8	3	230				L30P4GJ	18-1/4	12	P43B0020A3	23		
	2		8	3	460				L30P4GJ	18-1/4	12	P43B0020A4	23		

*Length and Weight are approximate.

**For 10 GPM, 15 GPM, 20 GPM and 30 GPM discharge is 1-1/4" NPT.

NOTE: On 2 HP and larger pumps – Motor, Control Box or Magnetic Starter must be ordered separately.

JP Series Signature 2000®

Composite

PUMP PERFORMANCE: 10 GPM

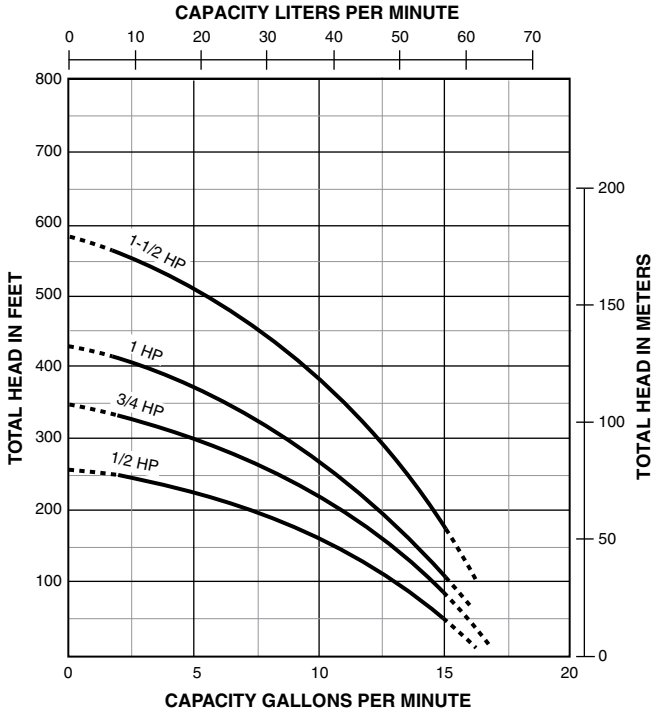

PUMP PERFORMANCE: 15 GPM

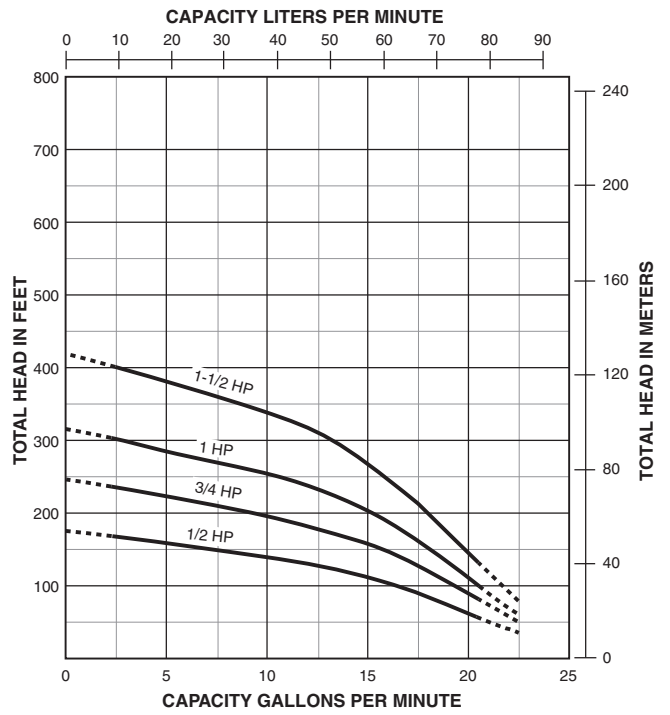

PUMP PERFORMANCE: 20 GPM

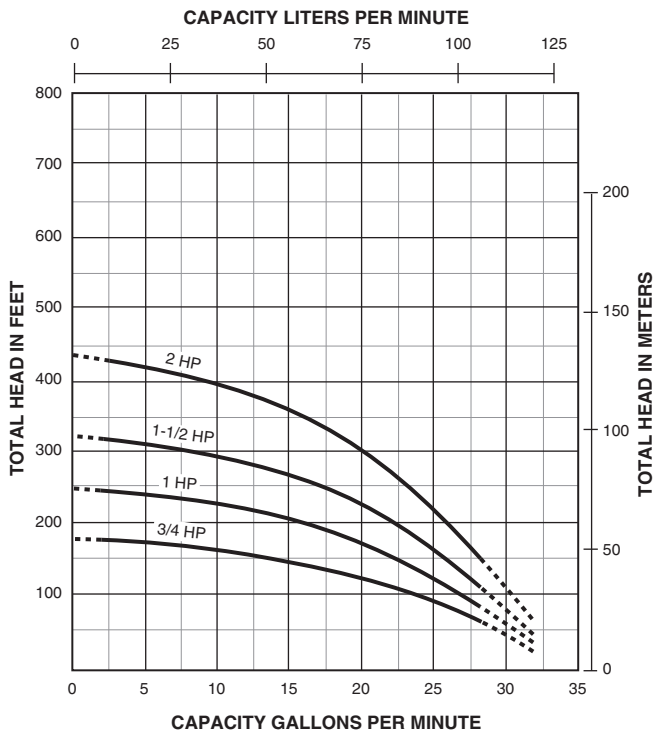

PUMP PERFORMANCE: 30 GPM

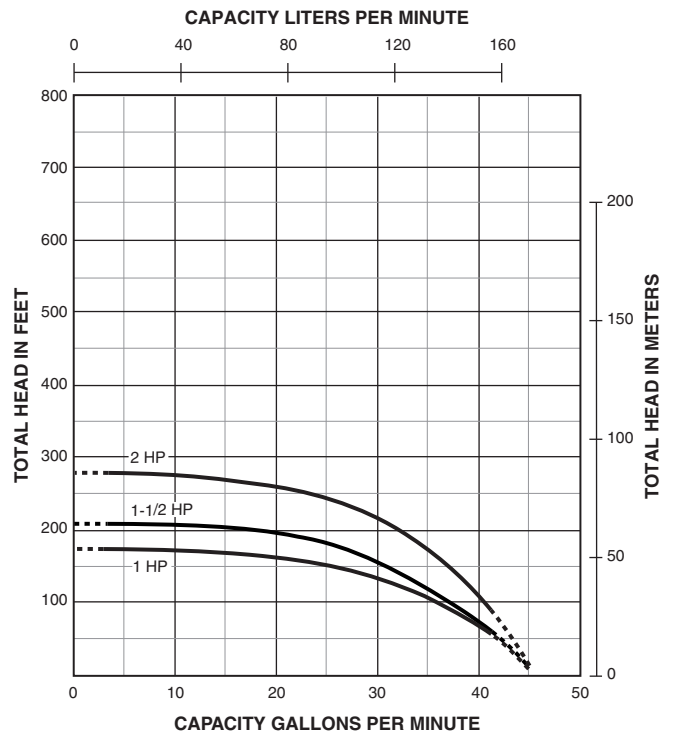

JP Series Signature 2000®

Composite

OUTLINE DIMENSIONS

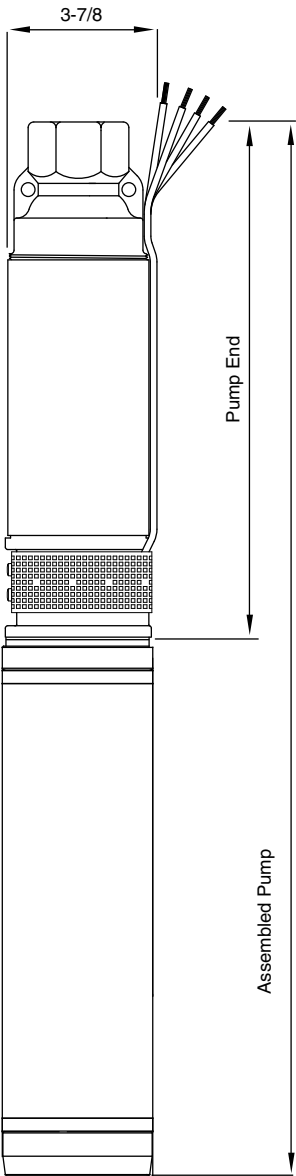

DISCHARGE

10 GPM	1-1/4" NPT
15 GPM	1-1/4" NPT
20 GPM	1-1/4" NPT
30 GPM	1-1/4" NPT

For lengths, refer to Ordering Information tables.
Dimensions (in inches) are for estimating purposes only.

JP Series Signature 2000®

Composite

10 GALLONS PER MINUTE																		PUMP PERFORMANCE (CAPACITY IN GALLONS PER MINUTE)																	
HP	PSI	PUMPING DEPTH IN FEET																SHUT-OFF HEAD																	
		20	40	60	80	100	125	150	175	200	250	300	350	400	450	500	550	600	FEET	PSI															
1/2	0	—	—	14.1	13.5	12.8	12.0	10.8	9.5	7.4	4.7								255	110															
	20	14.0	13.3	12.7	12.0	11.0	9.6	7.8	5.2	1.4																									
	30	13.2	12.6	11.8	10.9	9.8	8.0	5.5	1.7																										
	40	12.4	11.7	10.8	9.7	8.2	8.8	2.0																											
	50	11.5	10.5	9.4	7.8	5.8	2.2																												
	60	10.4	9.2	7.5	5.4	2.8																													
3/4	0	—	—	—	14.8	14.4	13.8	13.0	12.0	11.0	8.4	4.7							340	147															
	20	—	14.7	14.3	13.7	13.0	12.2	11.2	9.9	8.6	5.0																								
	30	14.4	14.2	13.7	13.0	12.3	11.2	10.0	8.8	7.2	3.0																								
	40	14.2	13.5	12.9	12.1	11.3	10.2	8.9	7.4	5.3																									
	50	13.4	12.7	12.0	11.0	10.2	8.9	7.4	5.5	3.2																									
	60	12.6	11.9	11.0	10.0	9.1	7.5	5.7	4.4	1.4																									
1	0	—	—	—	—	14.9	14.4	13.8	13.3	12.8	11.5	10.1	8.2	5.8	2.1				467	202															
	20	—	—	14.7	14.4	14.0	13.4	12.9	12.3	11.7	10.2	8.3	6.0	2.6																					
	30	—	14.7	14.4	13.8	13.4	12.9	12.3	11.7	11.0	9.4	7.4	4.6																						
	40	14.6	14.2	13.8	13.3	13.0	12.5	11.8	11.1	10.3	8.5	6.2	3.0																						
	50	14.1	13.7	13.3	12.9	12.4	11.8	11.1	10.2	9.5	7.4	4.8																							
	60	13.7	13.2	12.8	12.4	11.9	11.2	10.3	9.5	8.7	6.3	3.2																							
1-1/2	0	—	—	—	—	—	—	14.7	14.4	14.0	13.2	12.2	11.2	10.1	8.6	7.1	5.2	2.5	636	275															
	20	—	—	—	—	14.8	14.4	14.0	13.6	13.2	12.4	11.3	10.2	8.7	7.3	5.3	2.8																		
	30	—	—	—	14.7	14.4	14.0	13.6	13.2	12.8	11.9	10.7	9.6	8.1	6.4	4.4																			
	40	—	15.0	14.7	14.4	14.1	13.7	13.3	12.8	12.4	11.4	10.2	8.9	7.3	5.5	3.0																			
	50	14.9	14.6	14.3	14.0	13.6	13.2	12.8	12.4	12.0	10.8	9.7	8.2	6.5	4.5																				
	60	14.5	14.3	14.0	13.6	13.3	12.8	12.4	12.0	11.5	10.2	9.0	7.5	5.6	3.3																				

CAUTION: DO NOT use pump at flow rates indicated by the symbol '—'. To do so can cause premature failure of unit. Pump warranty void when failure occurs under these conditions. Tested and rated in accordance with Water Systems Council Standards.

NOTE: Pumps installed with a Pro-Source® tank require a 100 PSI relief valve. Pumps installed with a conventional tank require a 75 PSI relief valve. Relief valve must be capable of relieving entire flow of pump at relief pressure.

JP Series Signature 2000®

Composite

15 GALLONS PER MINUTE																	PUMP PERFORMANCE (CAPACITY IN GALLONS PER MINUTE)		
HP	PSI	PUMPING DEPTH IN FEET															SHUT-OFF HEAD		
		20	40	60	80	100	125	150	175	200	250	300	350	400	450	500	FEET	PSI	
1/2	0	—	21.5	20.0	18.7	16.9	13.1	7.4									175	76	
	20	19.7	18.3	16.3	13.0	8.8													
	30	18.0	15.6	12.4	7.9	2.0													
	40	15.2	11.9	7.0															
	50	11.2	5.8																
	60	4.8																	
3/4	0	—	—	21.2	20.2	19.3	17.8	16.0	13.2	9.6							245	106	
	20	20.9	19.9	19.0	17.7	16.4	13.7	10.0	4.9										
	30	19.8	18.8	17.6	16.1	14.0	10.7	5.5											
	40	18.6	17.5	15.9	13.5	10.9	6.0												
	50	17.2	15.4	13.1	10.0	6.4													
	60	15.0	12.7	9.7	5.5	1.8													
1	0	—	—	—	—	20.4	19.4	18.4	17.2	15.5	10.3	2.7					318	138	
	20	—	20.9	20.2	19.3	18.7	17.5	15.8	13.4	10.9	3.2								
	30	20.8	20.0	19.1	18.5	17.6	16.0	13.7	11.1	7.5									
	40	19.8	19.0	18.3	17.4	16.2	13.9	11.3	8.1	3.7									
	50	18.9	18.2	17.1	15.8	14.0	11.4	8.2	4.0										
	60	18.0	17.0	15.6	13.7	11.7	8.4	4.4											
1-1/2	0	—	—	—	—	—	20.5	19.9	19.3	18.4	16.4	13.1	8.3	2.8			420	182	
	20	—	—	21.2	20.5	20.0	19.3	18.6	17.6	16.5	13.5	9.1	3.2						
	30	—	21.1	20.3	19.9	19.3	18.7	17.7	16.6	15.4	11.7	6.3							
	40	21.0	20.2	19.8	19.2	18.7	17.9	16.7	15.5	13.7	9.4	3.6							
	50	20.2	19.7	19.2	18.6	18.0	16.8	15.6	13.8	11.9	6.7								
	60	19.6	19.0	18.5	17.7	16.9	15.7	13.9	12.0	9.7	3.8								

CAUTION: DO NOT use pump at flow rates indicated by the symbol '—'. To do so can cause premature failure of unit. Pump warranty void when failure occurs under these conditions.

Tested and rated in accordance with Water Systems Council Standards.

NOTE: Pumps installed with a Pro-Source® tank require a 100 PSI relief valve. Pumps installed with a conventional tank require a 75 PSI relief valve. Relief valve must be capable of relieving entire flow of pump at relief pressure.

JP Series Signature 2000®

Composite

20 GALLONS PER MINUTE																PUMP PERFORMANCE (CAPACITY IN GALLONS PER MINUTE)	
HP	PSI	PUMPING DEPTH IN FEET														SHUT-OFF HEAD	
		20	40	60	80	100	125	150	175	200	250	300	350	400	450	FEET	PSI
3/4	0	—	—	—	26.9	23.5	19.0	13.7								180	78
	20	—	25.8	22.5	18.5	14.5	3.4										
	30	25.2	22.0	18.3	13.9	4.5											
	40	21.3	17.6	13.0	3.0												
	50	17.2	11.4														
	60	10.2															
1	0	—	—	—	—	—	25.3	22.4	18.8	15.5					251	109	
	20	—	—	—	25.1	22.8	19.5	16.1	10.1								
	30	—	—	24.9	22.5	19.8	16.5	10.6									
	40	27.0	24.5	22.0	19.4	16.8	11.6	2.6									
	50	24.2	21.5	19.0	16.3	12.5	3.3										
	60	21.3	18.6	16.0	11.1	3.7											
1-1/2	0	—	—	—	—	—	—	26.4	24.0	21.6	16.4	5.4			323	140	
	20	—	—	—	—	26.8	24.4	22.0	19.5	16.8	6.8						
	30	—	—	—	26.5	24.7	22.2	19.6	17.1	13.9							
	40	—	—	26.2	24.3	22.3	19.8	17.3	14.2	8.0							
	50	—	26.0	24.1	22.1	20.0	17.5	14.5	8.3								
	60	25.6	23.9	21.9	19.8	17.5	14.8	9.1									
2	0	—	—	—	—	—	—	—	27.3	26.0	23.2	20.2	16.2	8.5	435	188	
	20	—	—	—	—	—	—	26.1	24.9	23.4	20.6	16.7	9.5				
	30	—	—	—	—	—	26.2	25.0	23.5	22.1	19.1	13.8	4.8				
	40	—	—	—	—	26.4	25.1	23.7	22.2	20.8	17.2	10.1					
	50	—	—	27.2	26.1	25.1	23.8	22.3	20.9	19.3	14.0	5.7					
	60	—	27.1	26.0	25.0	23.9	22.4	21.0	19.4	17.3	10.8						

CAUTION: DO NOT use pump at flow rates indicated by the symbol '—'. To do so can cause premature failure of unit. Pump warranty void when failure occurs under these conditions. Tested and rated in accordance with Water Systems Council Standards.

NOTE: Pumps installed with a Pro-Source® tank require a 100 PSI relief valve. Pumps installed with a conventional tank require a 75 PSI relief valve. Relief valve must be capable of relieving entire flow of pump at relief pressure.

JP Series Signature 2000®

Composite

30 GALLONS PER MINUTE																PUMP PERFORMANCE (CAPACITY IN GALLONS PER MINUTE)	
HP	PSI	PUMPING DEPTH IN FEET														SHUT-OFF HEAD	
		20	40	60	80	100	125	150	175	200	250	300	350	400	450	FEET	PSI
1	0	—	—	40.9	39.1	36.8	32.5	26.0	8.0							175	76
	20	40.4	38.8	36.0	32.4	27.7	13.3										
	30	38.0	35.3	31.7	26.3	14.3											
	40	35.0	31.4	25.9	12.1												
	50	30.2	24.0	3.0													
	60	21.9															
1-1/2	0	—	—	41.9	39.9	37.5	34.1	30.9	26.9	17.0					210	91	
	20	41.2	39.1	36.5	34.0	31.5	27.8	21.5									
	30	38.9	36.1	33.8	31.0	27.9	21.8										
	40	36.0	33.5	30.8	27.7	20.2											
	50	32.9	30.1	26.8	21.5												
	60	29.5	25.9	18.1													
2	0	—	—	—	41.8	40.5	38.8	36.8	34.7	31.6	23.7				280	121	
	20	—	41.3	40.1	38.7	37.1	34.9	32.1	29.0	24.8							
	30	41.2	40.0	38.5	37.0	35.0	32.2	29.1	24.9	15.2							
	40	39.9	38.3	36.6	34.8	32.7	29.8	25.1	16.1								
	50	38.0	36.3	34.5	32.1	30.0	25.3	17.5									
	60	36.0	34.0	31.9	29.1	26.0	18.0										

CAUTION: DO NOT use pump at flow rates indicated by the symbol '—'. To do so can cause premature failure of unit. Pump warranty void when failure occurs under these conditions. Tested and rated in accordance with Water Systems Council Standards.

NOTE: Pumps installed with a Pro-Source® tank require a 100 PSI relief valve. Pumps installed with a conventional tank require a 75 PSI relief valve. Relief valve must be capable of relieving entire flow of pump at relief pressure.

70 GPM Series

Cast Iron



Precision-engineered, quality-built and rugged 70 GPM Series submersibles may be used in wells 4" or larger. Maximum outside diameter 3-7/8".

APPLICATIONS

Water systems...for residential, industrial, commercial, multiple housing and farm use.

SPECIFICATIONS

Discharge: Cast iron, ASTM A48 Class 30

Pump Bowls: Cast iron, ASTM A48 Class 30

Impellers: Polycarbonate with brass insert

Collets: Stainless steel, AISI 416

Upthrust Bearing: Bronze, ASTM B255 Type II

Pump Shaft: Stainless steel, AISI 416

Bowl and Intake Bearings: Nitrile (proprietary spec.)

Lead Guard: Stainless steel, AISI 430

Intake Bracket: Cast iron, ASTM A48 Class 30

Screen: Stainless steel, AISI 430

Pump/Motor Coupling: Stainless steel, AISI 416

FEATURES

Discharge: Heavy-duty cast iron construction provides smooth water passage to column pipe. NPT threads standard.

Bowl and Intake Bearings: Fluted, cutless rubber type assures superior abrasive-handling characteristics, located at each stage.

Polycarbonate Impellers: Glass-reinforced polycarbonate resists abrasives and provides smooth water passages for minimum friction loss. Ensures optimum pump efficiency.

Pump Bowls: Highly efficient hydraulic design...threaded bowl design in gray cast iron.

Upthrust Bearing: Bronze upthrust bearing provides positive momentary upthrust protection during start-up.

Intake Bracket: Efficient hydraulic design minimizes entrance losses, ensuring maximum pump performance.

Stainless Steel Pump Shaft: Precision straightened shaft is corrosion-resistant stainless steel.

Pump/Motor Coupling: Stainless steel for maximum corrosion resistance...precision machined to ensure accurate alignment and power transfer.

Intake Screen: Stainless steel material offers maximum corrosion resistance...protects against damaging solids entering the pump assembly.

70 GPM Series

Cast Iron

ORDERING INFORMATION

MOTOR TYPE	HP	STGS.	PH	VOLT	PUMP END			MOTOR		CONTROL BOX	
					CATALOG NUMBER	LENGTH INCHES*	WEIGHT POUNDS*	CATALOG NUMBER	WEIGHT POUNDS*	CATALOG NUMBER	WEIGHT POUNDS*
2 WIRE	1-1/2	4	1	230	L70F4	20-25/32	26	P42B0015A2	29		
	1-1/2	4	1	230	L70F4	20-25/32	26	P43B0015A2	27	SMC-CR1521	7
	1-1/2	4	3	230	L70F4	20-25/32	26	P43B0015A3	23		
	1-1/2	4	3	460	L70F4	20-25/32	26	P43B0015A4	23		
	2	5	1	230	L70G4	24-1/16	31	P43B0020A2	31	SMC-CR2021	7
	2	5	3	230	L70G4	24-1/16	31	P43B0020A3	27		
3 WIRE	2	5	3	460	L70G4	24-1/16	31	P43B0020A4	27		
	3	7	1	230	L70H4	30-5/8	39	P43B0030A2	40	SMC-CR3021	7
	3	7	3	230	L70H4	30-5/8	39	P43B0030A3	32		
	3	7	3	460	L70H4	30-5/8	39	P43B0030A4	32		
	5	12	1	230	L70J4	47-1/32	60	P43B0050A2	70	SMC-CR5021	8
	5	12	3	230	L70J4	47-1/32	60	P43B0050A3	55		
	5	12	3	460	L70J4	47-1/32	60	P43B0050A4	55		
	7-1/2	17	3	230	L70K4	63-7/16	81	P43B0075A3	70		
	7-1/2	17	3	460	L70K4	63-7/16	81	P43B0075A4	70		
	10	23	3	460	L70L4	83-1/8	106	P43B0100A4	70		

*Length and Weight are approximate.

NOTE: Pump end and motor purchased separately.

OUTLINE DIMENSIONS

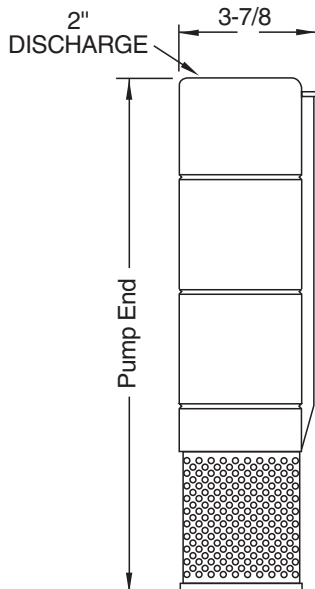

For lengths, refer to Ordering Information tables.

PUMP PERFORMANCE: 70 GPM

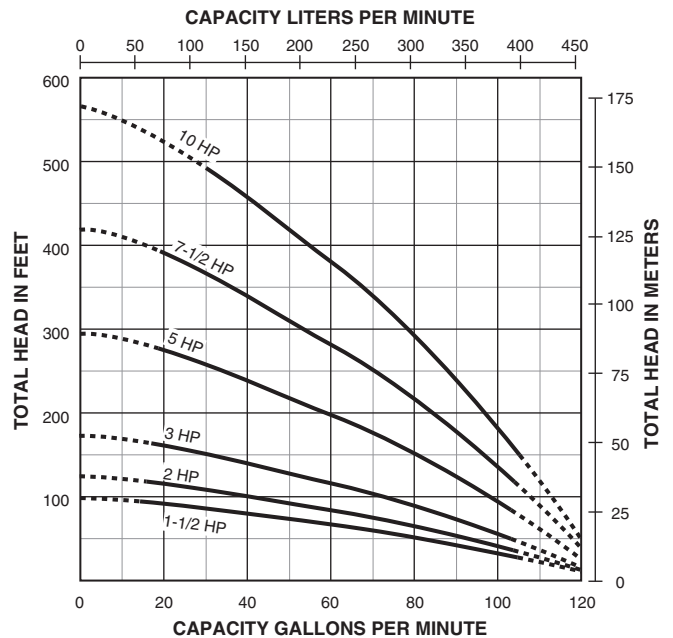

Dimensions (in inches) are for estimating purposes only.

Tested and rated in accordance with Water Systems Council Standards.

NOTE: Pumps installed with a Pro-Source® tank require a 100 PSI relief valve. Pumps installed with a conventional tank require a 75 PSI relief valve. Relief valve must be capable of relieving entire flow of pump at relief pressure.

70 GPM Series

Cast Iron

70 GALLONS PER MINUTE		PUMP PERFORMANCE (CAPACITY IN GALLONS PER MINUTE)																						
HP	PSI	PUMPING DEPTH IN FEET																						
		20	40	60	80	100	125	150	175	200	225	250	275	300	325	350	375	400	425	450	475	500	525	550
1-1/2	0	—	92.5	70.0	40.0																			
	20	61.5	31.0																					
	30	25.0																						
	40																							
	50																							
	60																							
2	0	—	100.0	85.0	64.0	40.0																		
	20	79.0	57.0	32.5																				
	30	52.5	28.0																					
	40	25.0																						
	50																							
	60																							
3	0	—	104.0	98.0	86.0	73.5	52.5	31.0																
	20	95.0	82.5	68.0	52.0	35.0																		
	30	81.0	66.0	49.0	32.0																			
	40	64.0	47.0	29.0																				
	50	43.0	25.5																					
	60	22.0																						
5	0	—	—	—	106.0	99.0	91.0	82.0	72.0	60.0	47.5	35.0	21.0											
	20	—	104.0	97.0	90.5	83.5	74.0	62.0	49.5	37.0	23.0													
	30	102.5	96.0	88.5	82.5	74.5	63.0	50.0	38.0	25.0														
	40	95.0	87.5	81.5	73.5	64.0	51.5	39.0	26.0															
	50	86.0	80.0	72.0	62.0	52.0	39.5	27.0																
	60	78.0	70.0	61.0	50.0	40.0	27.5																	
7-1/2	0	—	—	—	—	108.0	103.0	97.0	91.0	85.0	78.0	75.0	62.5	54.0	45.5	35.5								
	20	—	—	108.0	102.5	97.5	92.0	86.0	80.0	76.0	64.9	56.0	47.0	37.5	27.5									
	30	—	107.5	102.0	97.0	92.5	87.0	80.5	76.5	65.0	56.5	47.5	38.0	28.0										
	40	107.0	101.5	96.5	92.0	87.5	81.5	77.0	65.5	57.0	48.0	38.5	29.0											
	50	101.0	96.0	91.0	86.0	82.0	77.0	66.0	57.5	48.0	39.0	30.0	20.0											
	60	95.0	90.0	85.0	80.5	77.5	66.5	57.5	49.0	40.0	31.0	21.0												
10	0	—	—	—	—	—	110.0	106.0	102.0	97.5	93.0	88.0	84.0	79.0	74.9	68.0	62.0	55.0	48.0	42.5	36.0			
	20	—	—	—	110.0	107.0	102.5	98.5	93.5	89.0	85.0	80.0	75.5	69.5	62.5	56.0	49.5	43.0	37.0	31.0				
	30	—	—	109.5	106.5	103.0	99.0	94.0	89.5	85.0	80.5	76.0	70.0	63.0	57.0	55.0	43.5	37.5	31.5					
	40	—	109.0	106.0	102.5	99.5	95.0	90.0	85.5	81.0	76.5	70.5	64.0	57.5	51.0	44.0	38.0	32.0						
	50	108.0	105.5	102.0	98.5	95.0	90.0	86.0	81.5	76.5	71.0	64.5	57.5	51.5	44.5	38.0	32.5							
	60	104.5	101.5	98.0	94.0	91.0	86.5	82.0	77.0	72.0	65.0	58.0	52.0	46.0	38.5	32.5								

CAUTION: DO NOT use pump at flow rates indicated by the symbol '—'. To do so can cause premature failure of unit. Pump warranty void when failure occurs under these conditions.

Tested and rated in accordance with Water Systems Council Standards.

NOTE: Pumps installed with a Pro-Source® tank require a 100 PSI relief valve. Pumps installed with a conventional tank require a 75 PSI relief valve. Relief valve must be capable of relieving entire flow of pump at relief pressure.

90 GPM Series High-Flo 4"

Stainless Steel



The 90 GPM Stainless Steel High-Flo 4" Submersible Pumps deliver efficient and dependable performance even in rough, aggressive water. Heads to 410 feet and capabilities to 120 GPM. Built to deliver long-term, trouble-free service. FDA-compliant engineered composite and stainless steel components.

APPLICATIONS

Water systems...for residential, industrial, commercial, multiple housing and farm use.

SPECIFICATIONS

Discharge: 300 grade stainless steel with 2" NPT threads

Top Bearing: Acetal

Top Bearing Journal: 300 grade stainless steel

Diffuser Assembly: Noryl® (20% glass filled) urethane 300 grade stainless steel

Upthrust Washers: Phenolic

Impellers: Polycarbonate (20% glass filled)

Impeller Eye Seals: Urethane

Bowls: Noryl (20% glass filled)

Intermediate Bearing: Acetal

Intermediate Bearing Journal: 300 grade stainless steel

Shaft: 300 grade stainless steel

Coupling: 300 grade stainless steel, 7/16" hex stock

Shell: 300 grade stainless steel

Motor Adapter: 300 grade stainless steel

Suction Screen: 300 grade stainless steel

Cable Guard: 300 grade stainless steel

Fasteners: 300 grade stainless steel

FEATURES

Discharge: Heavy-duty 300 grade stainless steel construction provides smooth water passage to column pipe. Large wrench flats and rope hole.

Top Bearing: Field-proven, sealed and lubricated top bearing assembly keeps abrasives out, ensuring long bearing life.

Impellers: 20% glass-reinforced polycarbonate to resist abrasives and provide smooth water passage for minimal friction loss.

Upthrust Bearing: Phenolic washers and stainless steel upthrust rings at each stage provide excellent wear-resistant surfaces.

Diffuser Bearing: Urethane bearings at each stage provide radial protection and stability, and excellent resistance to sand damage.

Motor Bracket: 300 grade precision cast stainless steel. Incorporates an efficient hydraulic design for maximum volume and access to motor mounting nuts.

Shaft: 300 grade "treated" stainless steel pump shaft is corrosion-resistant. The hex shape offers generous impeller drive surfaces.

Motor Coupling: Pressed-on, sintered 300 grade stainless steel for maximum corrosion resistance provides trouble-free transfer of power between motor and pump shaft.

Shell: Heavy-gauge, 300 series stainless steel pump shell is durable and offers high corrosion resistance.

Intake Screen: 300 series stainless steel material offers maximum corrosion resistance and protects against damaging solids entering the pump.

90 GPM Series High-Flo 4"

Stainless Steel

ORDERING INFORMATION

MOTOR TYPE	HP	STGS.	PH	VOLT	PUMP END			MOTOR		CONTROL BOX	
					CATALOG NUMBER	LENGTH INCHES*	WEIGHT POUNDS*	CATALOG NUMBER	WEIGHT POUNDS*	CATALOG NUMBER	WEIGHT POUNDS*
3 WIRE	2	5	1	230	L90HF20	21	15	P43B0020A2	31	SMC-CR2021	7
			3	230	L90HF20	21	15	P43B0020A3	31		
			3	460	L90HF20	21	15	P43B0020A4	31		
	3	7	1	230	L90HF30	26-5/8	17	P43B0030A2	40	SMC-CR3021	7
			3	230	L90HF30	26-5/8	17	P43B0030A3	32		
			3	460	L90HF30	26-5/8	17	P43B0030A4	32		
	5	12	1	230	L90HF50	41-1/2	19	P43B0050A2	70	SMC-CR5021	8
			3	230	L90HF50	41-1/2	19	P43B0050A3	55		
			3	460	L90HF50	41-1/2	19	P43B0050A4	55		
	7-1/2	17	3	230	L90HF75	56	26	P43B0075A3	70		
			3	460	L90HF75	56	26	P43B0075A4	70		
	10	23	3	460	L90HF100	72-3/8	35	P43B0100A4	78		

*Length and Weight are approximate.

CROSS-SECTIONAL VIEW/OUTLINE DIMENSIONS

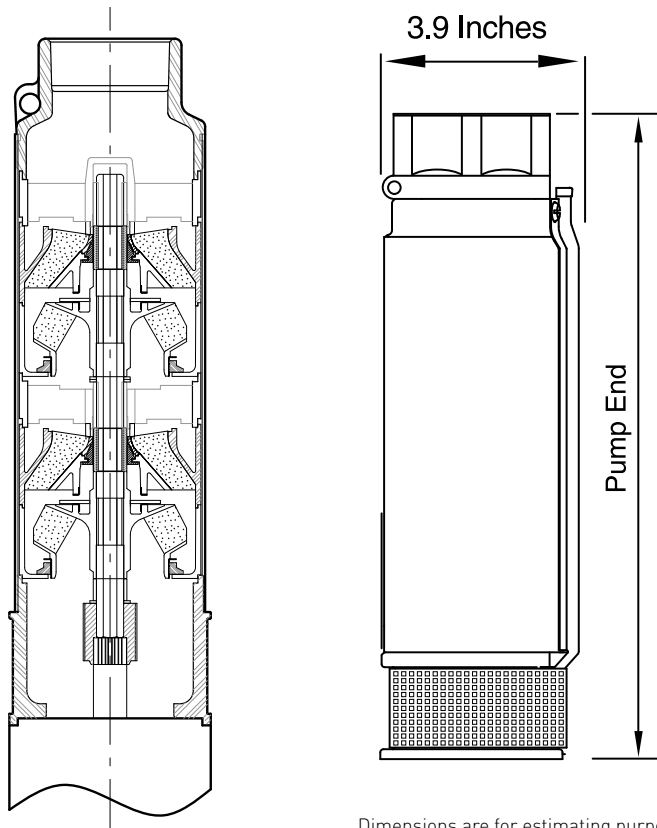

MODEL NUMBER	DISCHARGE
L90HF20	2" NPT
L90HF30	
L90HF50	
L90HF75	
L90HF100	

For lengths, refer to Ordering Information tables.

Dimensions are for estimating purposes only.

90 GPM Series High-Flo 4"

Stainless Steel

90 GALLONS PER MINUTE

PUMP PERFORMANCE (CAPACITY IN GALLONS PER MINUTE)

HP	PSI	PUMPING DEPTH IN FEET													SHUT-OFF HEAD	
		20	40	60	80	100	125	150	175	200	250	300	350	400	FEET	PSI
2	0	-	115	90	60										109	48
	20	80	53													
	30	50														
	40															
	50															
	60															
3	0	-	-	113	96	75	50							153	67	
	20	108	90	69	50											
	30	87	66													
	40															
	50															
	60															
5	0	-	-	-	-	115	103	86	72	56				258	112	
	20	-	122	112	102	88	74	59								
	30	119	111	101	87	73	58									
	40	108	98	84	72	57										
	50	96	83	71	56											
	60	82	70	55												
7-1/2	0	-	-	-	-	124	116	108	103	92	73	50		402	175	
	20	-	-	122	116	110	101	93	87	74	52					
	30	-	121	115	109	102	94	84	79	65						
	40	120	114	108	101	94	85	76	70	54						
	50	113	107	100	93	86	76	66	60							
	60	106	99	92	85	77	67	56								
10	0	-	-	-	-	-	-	-	118	112	99	81	66	52	491	213
	20	-	-	-	-	-	119	113	106	100	83	67	53			
	30	-	-	-	-	120	114	107	101	93	75	60				
	40	-	-	-	119	114	107	101	94	84	68	54				
	50	-	-	118	114	108	102	95	85	77	62					
	60	125	117	113	108	102	94	86	78	70	55					

PUMP PERFORMANCE: 90 GPM

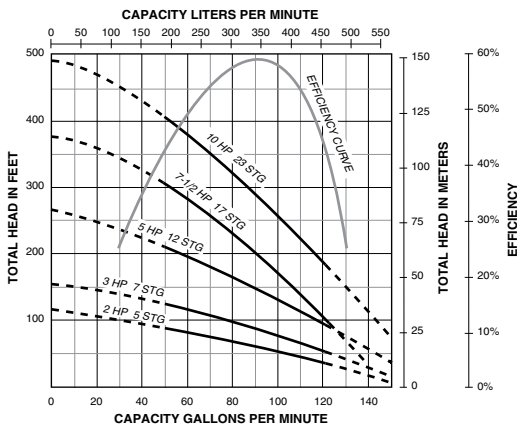

4"x6" Submersible Motor Adapter

Stainless Steel



The PKG 4x6, Pump/Motor Adapter offers the professional distributor and dealer the flexibility to stock standard 4" submersible pump ends, and 4" and 6" motors, better utilizing inventory dollars and delivery demands!

APPLICATIONS

Water systems...for residential, industrial, commercial, multiple housing and farm use.

ORDERING INFORMATION

CATALOG NUMBER	PUMP END*	MOTOR*	MAXIMUM HP	WEIGHT POUNDS**
PKG 4x6	4" NEMA	6" NEMA	10	5

*Pump end and motor ordered separately.

**Shipping weight is approximate.

FEATURES

Extends Single-Phase Power

Availability: To all Signature 2000® submersibles through 10 HP using 6" single-phase motors.

Easy Assembly: Easy job-site assembly.

Double-Suction Screens: Reduces inlet suction velocity, reducing the amount of suspended solids ingested by pump.



SPECIFICATIONS

Adapter Casting: Stainless steel

Coupling: Stainless steel

Intake Screen: Stainless steel

Beveled Wire Forms: Stainless steel

Socket Head Cap-Screws: Stainless steel

Studs: Stainless steel

Fasteners: Stainless steel

PENTEK® XE Series™ Motors

Stainless Steel



Introducing the new Pentek® XE Series™ 4" submersible high-thrust motors. Built with the latest design, manufacturing and testing technology, they feature laser-welded 304L stainless steel construction, higher thrust capacities and higher efficiencies. The Pentek XE Series submersible motors incorporate “encapsulated, epoxy stator design,” and professional-grade Class F insulation provides longer life in harsh environments. Each motor is 100% factory pressure and run tested to support our quality standards.

APPLICATIONS

Water systems...for residential, industrial, commercial, multiple housing and farm clean water use.

SPECIFICATIONS

End Bell: 304 stainless steel

Shell: 304 stainless steel

Motor Shaft: 17-4 precipitation hardened stainless steel

Insulation: Class F, 311°F (155°C)

Max. Water Temp: 86°F (30°C)

Fasteners: 304 stainless steel

Sand Boot: Nitrile

Cable: Field-serviceable, Controlled Compression Design, UL and CSA Approved

Cable Length: 48"

Diaphragm: EPDM

Thrust Bearings: Kingsbury-type, pivot shoe, carbon graphite mating ring

Thrust Load Capacity: 700 lbs.

FEATURES

700# Rated Kingsbury Thrust Bearing Design: Large high-performance bearings are standard on all HPs allowing for higher thrust loads, providing many years of trouble-free service under severe-duty operation.

2-Wire Permanent Split Capacitor: Design insures quiet operation and improved operating efficiency.

3-Wire Motors: Operate with Pentek SMC and other single-phase motor controls.

All Stainless Steel Exterior Professional-Grade Class F-Compliant Motor Insulation: Allows for longer service life.

UL, CSA Approved and NSF/ANSI 61 Certified

100% Factory Pressure and Run Tested

Equipped with Surge Arrestor

Automatic Thermal Protection on 1/2 – 1 HP Models

PENTEK® XE Series™ Motors

Stainless Steel

ORDERING INFORMATION

RATING				SERVICE FACTOR	CATALOG NUMBER	FULL LOAD AMPS	MAX. LOAD (SF LOAD) AMPS	LOCKED ROTOR AMPS	WINDING		THRUST RATING	LENGTH		WEIGHT			
HP	kW	VOLTS	Hz						MAIN RESISTANCE	START RESISTANCE		IN.	MM	LB.	KG		
PERMANENT SPLIT CAPACITOR (PSC) 2 WIRE																	
1/2	0.37	115	60	1.6	P42B0005A1	7.4	9.5	36.4	1.3-1.8	700		11.0	279	19.2	8.7		
		230		1.6	P42B0005A2	3.7	4.7	19.5	4.5-5.2			11.0	279	19.2	8.7		
3/4	0.55	230		1.5	P42B0007A2	5.0	6.4	24.8	3.0-4.8			12.4	314	22.7	10.3		
1	0.75	230		1.4	P42B0010A2	7.9	9.1	21.7	4.2-5.2			13.0	337	24.5	11.1		
1-1/2	1.1	230		1.3	P42B0015A2	9.2	11.0	42.0	1.9-2.3			14.9	378	28.9	13.1		
CAPACITOR START/INDUCTION RUN (CSIR) 3 WIRE																	
1/2	0.37	115	60	1.6	P43B0005A1	11.0	12.6	49.6	0.9-1.6	5.7-7.0	700	10.0	253	18.9	8.6		
		230		1.6	P43B0005A2	5.5	6.3	22.3	4.2-4.9	17.4-18.7		9.7	246	18.1	8.2		
3/4	0.55	230		1.5	P43B0007A2	7.2	8.3	32.0	2.6-3.6	11.8-13.0		10.8	275	21.4	9.7		
1	0.75	230		1.4	P43B0010A2	8.4	9.7	41.2	2.2-3.2	11.3-12.3		11.7	297	23.1	10.5		
CAPICITOR START/CAPACITOR RUN (CSCR) 3 WIRE																	
1/2	0.37	230	60	1.6	P43B0005A2	4.1	4.9	22.3	4.2-4.9	17.4-18.7	700	9.7	246	18.1	8.2		
3/4	0.55			1.5	P43B0007A2	5.1	6.3	32.0	2.6-3.6	11.8-13.0		10.8	275	21.4	9.7		
1	0.75			1.4	P43B0010A2	6.1	7.2	41.2	2.2-3.2	11.3-12.3		11.7	297	23.1	10.5		
1-1/2	1.1			1.3	P43B0015A2	9.7	11.1	47.8	1.6-2.3	7.9-8.7		13.6	345	27.4	12.4		
2	1.5			1.25	P43B0020A2	9.9	12.2	49.4	1.6-2.2	10.8-12.0	15.1	383	31.0	14.1			
3	2.2			1.15	P43B0030A2	14.3	16.5	76.4	1.1-1.4	2.0-2.5	18.3	466	40.0	18.1			
5	3.7			1.15	P43B0050A2	24.0	27.0	101.0	0.62-0.76	1.36-1.66	1500	27.7	703	70.0	31.8		
3 PHASE																	
RATING				SERVICE FACTOR	CATALOG NUMBER	FULL LOAD AMPS	MAX. LOAD (SF LOAD) AMPS	LINE TO LINE RESISTANCE OHMS	LOCKED ROTOR AMPS	THRUST RATING	LENGTH		WEIGHT				
HP	kW										VOLTS	Hz	IN.	MM	LB.	KG	
1/2	0.37	200	60	1.6	P43B0005A8	2.9	3.4	4.1-5.2	22.0	700	10.0	254	18.9	8.6			
		230			P43B0005A3	2.4	2.9	5.72-7.2	17.3		10.0	254	18.9	8.6			
		460			P43B0005A4	1.3	1.5	23.6-26.1	9.0		10.0	254	18.9	8.6			
3/4	0.55	200	60	1.5	P43B0007A8	3.8	4.5	2.6-3.0	32.0		10.8	274	21.4	9.7			
		230			P43B0007A3	3.3	3.9	3.3-4.3	27.0		10.8	274	21.4	9.7			
		460			P43B0007A4	1.7	2.0	14.4-16.2	14.0		10.8	274	21.4	9.7			
1	0.75	200	60	1.4	P43B0010A8	4.6	5.5	3.4-3.9	29.0		11.7	297	23.1	10.5			
		230			P43B0010A3	4.0	4.7	4.1-5.1	26.1		11.7	297	23.1	10.5			
		460			P43B0010A4	2.2	2.5	17.8-18.8	13.0		11.7	297	23.1	10.5			
1-1/2	1.1	200	60	1.3	P43B0015A8	6.3	7.2	1.9-2.5	40.0		11.7	297	23.1	10.5			
		230			P43B0015A3	5.2	6.1	2.8-3.4	32.4	11.7	297	23.1	10.5				
		460			P43B0015A4	2.8	3.2	12.3-13.1	16.3	11.7	297	23.1	10.5				
2	1.5	575	60	1.25	P43B0015A5	2.0	2.4	19.8-20.6	11.5	11.7	297	23.1	10.5				
		200			P43B0020A8	7.5	8.8	1.4-2.0	51.0	13.8	351	27.4	12.4				
		230			P43B0020A3	6.5	7.6	1.8-2.4	44.0	13.8	351	27.4	12.4				
3	2.2	460	60	1.15	P43B0020A4	3.3	3.8	8.00-8.67	23.0	13.8	351	27.4	12.4				
		575			P43B0020A5	2.7	3.3	9.4-9.7	21.4	15.3	389	32.0	14.5				
		200			P43B0030A8	10.9	12.0	0.9-1.3	71.0	15.3	389	32.0	14.5				
5	3.7	230	60	1.15	P43B0030A3	9.2	10.1	1.3-1.7	58.9	15.3	389	32.0	14.5				
		460			P43B0030A4	4.8	5.3	5.9-6.5	30.0	15.3	389	32.0	14.5				
		575			P43B0030A5	3.7	4.1	9.4-9.7	21.4	15.3	389	32.0	14.5				
7-1/2	5.6	200	60	1.15	P43B0050A8	18.3	20.2	0.4-0.8	113.0	21.7	551	55.0	24.9				
		230			P43B0050A3	15.7	17.5	0.85-1.25	93.0	21.7	551	55.0	24.9				
		460			P43B0050A4	7.6	8.5	3.58-4.00	48.0	21.7	551	55.0	24.9				
10	7.5	575	60	1.15	P43B0050A5	7.0	7.6	3.6-4.2	55.0	27.7	703	70.0	31.8				
		200			P43B0075A8	27.0	30.0	0.5-0.6	165.0	27.7	703	70.0	31.8				
		230			P43B0075A3	24.0	26.4	0.55-0.85	140.0	27.7	703	70.0	31.8				
		460			P43B0075A4	12.2	13.5	1.9-2.3	87.0	27.7	703	70.0	31.8				
		575			P43B0075A5	9.1	10.0	3.6-4.2	55.0	27.7	703	70.0	31.8				
		460		1.15	P43B0100A4	15.6	17.2	1.8-2.2	110.0	30.7	780	78.0	35.4				

NOTE: Amp ratings on 3-wire motors reflect use with CSIR controls. A CSCR control is recommended for lower values.

PENTEK® XE Series™ Motors

Stainless Steel

OUTLINE DIMENSIONS

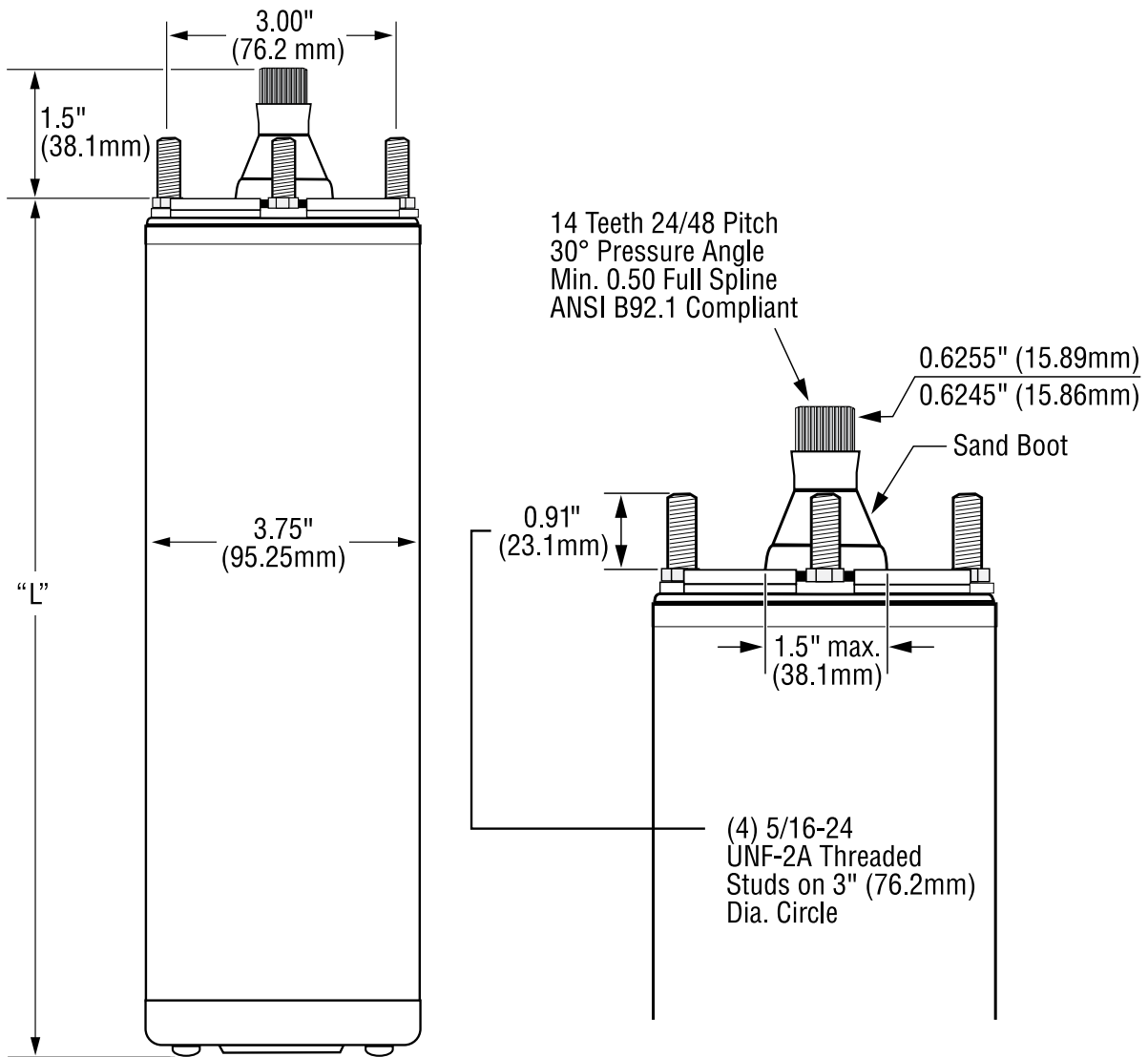

Dimensions (in inches) are for estimating purposes only.

LEAD LENGTH

CATALOG NUMBER	# OF WIRES	TYPE	LENGTH	GAUGE
P18-1485K	2 Wire	XLPE	48"	14 Ga
P18-1486K	3 Wire	XLPE	48"	14 Ga
P18-1486K	3 Wire	XLPE	48"	14 Ga
P18-1486K	3 Wire	XLPE	48"	14 Ga

XE SERIES REPLACEMENT MOTOR LEADS

CATALOG NUMBER	# OF WIRES	TYPE	LENGTH	GAUGE
P18-1485K	2 Wire	XLPE	48"	14 Ga
P18-1486K	3 Wire	XLPE	48"	14 Ga
P18-1486K	3 Wire	XLPE	48"	14 Ga
P18-1486K	3 Wire	XLPE	48"	14 Ga

Cable Selection

Stainless Steel

TWO DIFFERENT CABLE SIZES CAN BE USED

The example below is for reference. Depending on the installation, any number of combinations may be used, as long as the total percentage length of the two cables used does not exceed 100%. This is to ensure that adequate voltage will be supplied to the motor.

EXAMPLE:
1 HP,
230 Volt, 3W,
1 PH Motor

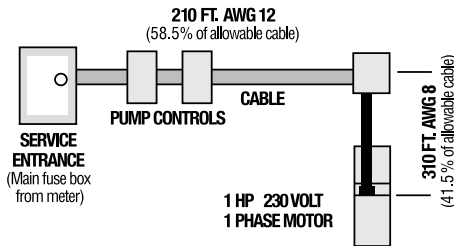

In a replacement installation, the well already has 210 feet of buried #12 cable between the service entrance and the well head. The question is: What size cable is required in the well with a 1 HP, 230 Volt, 1 PH, 3W motor setting at 310 feet?

1. According to the table, #12 cable is large enough for the 1 HP motor so the percent of the maximum allowable cable used by the 210-foot run is $210 \div 359 = 58.5\%$, since 359 feet is the total allowable.
2. With 58.5% of the total allowable cable already used between the service entrance and the well head, only 41.5% is left for the well. Therefore, the 310 feet needed in the well can only utilize 41.5% of the total feet allowed in the table.
3. From the table, 41.5% of the 573 feet for #10 cable equals only 238 feet, so a larger size is needed. For #8, 41.5% of 908 feet = 377 feet. As a result, #8 can be used for the 310 feet in the well.

CAUTION Use of wire size smaller than listed will void warranty.

MOTOR LEAD LENGTHS: PENTEK® 2-WIRE MOTORS

60 HZ MOTOR RATING		60C AND 75C INSULATION - AWG COPPER WIRE SIZE												
VOLTS	HP	14	12	10	8	6	4	3	2	1	1/0	2/0	3/0	4/0
230	1/2	115	183	293	463	721	1150	1445	1825	2299	2902	3662	4623	5824
	3/4	466	742	1183	1874	2915	4648	5843	7379	9295	11733			
	1	342	545	869	1376	2141	3413	4291	5419	6826	8617	10871		
	1-1/2	241	383	611	968	1506	2400	3018	3811	4801	6060	7646	9652	
	1-1/2	199	317	505	801	1246	1986	2496	3153	3972	5013	6325	7985	

MOTOR LEAD LENGTHS: PENTEK 3-WIRE PSC MOTORS

CSIR CONTROL BOXES

60 HZ MOTOR RATING		60C AND 75C INSULATION - AWG COPPER WIRE SIZE												
VOLTS	HP	14	12	10	8	6	4	3	2	1	1/0	2/0	3/0	4/0
230	1/2	87	138	221	349	544	867	1090	1376	1734	2188	2761	3485	4391
	3/4	348	553	883	1398	2175	3467	4359	5505	6935	8753			
	1	264	420	670	1061	1651	2632	3309	4178	5264	6644	8383		
	1	226	359	573	908	1413	2252	2831	3575	4504	5685	7173		

CSCR CONTROL BOXES

60 HZ MOTOR RATING		60C AND 75C INSULATION - AWG COPPER WIRE SIZE												
VOLTS	HP	14	12	10	8	6	4	3	2	1	1/0	2/0	3/0	4/0
230	1/2	447	711	1135	1797	2796	4458	5604	7078	8916	11254			
	3/4	348	553	883	1398	2175	3467	4359	5505	6935	8753	11044		
	1	304	484	772	1223	1903	3034	3814	4817	6068	7659	9663		
	1-1/2	197	314	501	793	1234	1968	2474	3124	3936	4968	6268		
	2	180	286	456	722	1123	1790	2251	2843	3581	4520	5703		
	3	133	211	337	534	830	1324	1664	2102	2648	3342	4217	5323	
	5			206	326	507	809	1017	1284	1618	2042	2577	3253	

All lengths in feet.

NOTE: Based on service factor amps, 30C ambient and 5% voltage drop.

(1) This table is based on copper wire. If aluminum wire is used it must be two sizes larger.

Example: When the table calls for #12 copper wire you would use #10 aluminum wire.

(2) Cables #14 to 4/0 are AWG sizes.

Cable Selection

Stainless Steel

MOTOR LEAD LENGTHS: PENTEK® 3-PHASE MOTORS

60 HZ MOTOR RATING		60C AND 75C INSULATION – AWG COPPER WIRE SIZE												
VOLTS	HP	14	12	10	8	6	4	3	2	1	1/0	2/0	3/0	4/0
200	0.5	657	1045	1667	2641	4109								
	3/4	423	674	1074	1702	2648								
	1	346	551	879	1392	2166	3454	4342						
	1.5	265	421	672	1064	1655	2638	3317						
	2	217	344	549	870	1354	2158	2714	3427	4317	5449			
	3	159	253	403	638	993	1583	1990	2513	3166	3996			
	5	94	150	239	379	590	940	1182	1493	1881	2374	2995	3781	4764
7.5	64	101	161	255	397	633	796	1005	1266	1598	2017	2546	3207	
230	0.5	756	1202	1917	3037	4725	7532	9469						
	0.75	562	894	1426	2258	3513	5601	7041	8892					
	1	466	742	1183	1874	2915	4648	5843	7379					
	1.5	359	571	912	1444	2246	3581	4502	5685	7162	9040			
	2	288	459	732	1159	1803	2874	3613	4563	5748	7256	9155		
	3	217	345	551	872	1357	2163	2719	3434	4326	5460	6889	8696	10956
	5			318	503	783	1248	1569	1982	2496	3151	3976	5019	6323
7.5				334	519	827	1040	1314	1655	2089	2635	3327	4192	
460	0.5	2922	4648	7414										
	0.75	2191	3486	5560	8806									
	1	1753	2789	4448	7045									
	1.5	1370	2179	3475	5504									
	2	1153	1835	2926	4635	7212								
	3	827	1315	2098	3323	5171								
	5	516	820	1308	2072	3224	5140							
	7.5	325	516	824	1305	2030	3236	4068	5138	6472				
	10	255	405	647	1024	1593	2540	3193	4033	5080				
575	1.5	2283	3631	5792										
	2	1660	2641	4212	6671									
	3	1336	2126	3390	5370									
	5	721	1147	1829	2897	4507								
	7.5	548	871	1390	2202	3426								

All lengths in feet.

NOTE: Based on service factor amps, 30C ambient and 5% voltage drop.

- (1) This table is based on copper wire. If aluminum wire is used it must be two sizes larger. Example: When the table calls for #12 copper wire you would use #10 aluminum wire.
- (2) The portion of the total cable that is between the service entrance and a 3-phase motor starter should not exceed 25% of the total maximum length to assure reliable starter operation.
- (3) Cables #14 to 4/0 are AWG sizes.

PENTEK® XE Series™ Coal Bed Methane Motors

Stainless Steel



The quality of the water-filled Pentek XE Series 4" submersible motors has been proven through years of operation in the field. The new Coal Bed Methane Series features water-filled motors which are built for reliability in potentially contaminated (sand or coal fines) well installations.

The Pentek XE Series gives you 40 different choices, including the new Coal Bed lineup:

230-Volt Single-Phase 2 to 5 HP

230-Volt Three-Phase 3 to 7.5 HP

460-Volt Three-Phase 3 to 10 HP

Pentek Coal Bed Methane Series Motors are rated for continuous duty in 86° F water, and feature a silicon carbide mechanical seal and diaphragm filter to help prevent sand/debris entry.

APPLICATIONS

Water systems...for residential, industrial, commercial, multiple housing and farm clean water use.

SPECIFICATIONS

End Bell: 304 stainless steel

Shell: 304 stainless steel

Motor Shaft: 17-4 precipitation hardened stainless steel

Insulation: Class F, 311°F (155°C)

Max. Water Temp: 86°F (30°C)

Fasteners: 304 stainless steel

Sand Boot: Nitrile

Cable: Field-serviceable, Controlled Compression Design, UL and CSA Approved

Cable Length: 80"

Diaphragm: Nitrile rubber

Thrust Bearings: Kingsbury-type, pivot shoe, carbon graphite mating ring

Thrust Load Capacity: Up to 1500 lbs.

FEATURES

Up to 1500# Rated Kingsbury Thrust Bearing Design: Large high-performance bearings are standard on all HPs allowing for higher thrust loads, providing many years of trouble-free service under severe-duty operation.

3-Wire Motors: Operate with Pentek SMC motor controls.

All Stainless Steel Exterior

Professional-Grade Class F-Compliant Motor Insulation: Allows for longer service life.

UL, CSA Approved and NSF/ANSI 61 Certified

100% Factory Pressure and Run Tested

Equipped with Surge Arrestor



PENTEK® XE Series™ Coal Bed Methane Motors

Stainless Steel

ORDERING INFORMATION

MOTOR TYPE	CATALOG NUMBER	RATING					FULL LOAD AMPS	MAX. LOAD (SF LOAD) AMPS	WINDING		LOCKED ROTOR AMPS	LENGTH		WEIGHT		THRUST RATING
		HP	KW	VOLTS	HZ	SERVICE FACTOR			MAIN RESISTANCE	START RESISTANCE		IN.	MM	LB	KG	
CSCR 3-WIRE	P43S0020A2	2	1.5	230	60	1.25	9.9	12.2	1.6-2.2	10.8-12.0	49.4	19.3	491	47.0	21.3	900
	P43S0030A2	3	2.2	230	60	1.15	14.3	16.5	1.1-1.4	2.0-2.5	76.4	22.3	567	53.0	24.0	
	P43S0050A2	5	3.7	230	60	1.15	24	27	0.62-0.76	1.36-1.66	101.0	28.6	726	74.0	33.6	1500

MOTOR TYPE	CATALOG NUMBER	RATING					FULL LOAD AMPS	MAX. LOAD (SF LOAD) AMPS	LINE TO LINE RESISTANCE OHMS	LOCKED ROTOR AMPS	LENGTH		WEIGHT		THRUST RATING
		HP	KW	VOLTS	HZ	SERVICE FACTOR					IN.	MM	LB	KG	
3-PHASE	P43S0030A3	3	2.2	230	60	1.15	9.2	10.1	1.3-1.7	58.9	19.3	491	47	21.3	900
	P43S0030A4	3	2.2	460	60	1.15	4.8	5.3	5.9-6.5	30.0	19.3	491	47	21.3	
	P43S0050A3	5	3.7	230	60	1.15	15.7	17.5	.85-1.25	93.0	22.6	573	59	26.8	1500
	P43S0050A4	5	3.7	460	60	1.15	7.6	8.5	3.58-4.00	48.0	22.6	573	59	26.8	
	P43S0075A3	7 1/2	5.6	230	60	1.15	24.0	26.4	0.55-0.85	140.0	28.6	726	74	33.6	
	P43S0075A4	7 1/2	5.6	460	60	1.15	12.2	13.5	1.9-2.3	87	28.6	726	74	33.6	
	P43S0100A4	10	7.5	460	60	1.15	15.6	17.2	1.8-2.2	110	31.6	802	80	36.3	

OUTLINE DIMENSIONS

DESCRIPTION			"LM" IN. (MM)	WEIGHT (LBS.)
HP	PHASE	VOLTAGE		
2	1	230	19.32 (490,7)	47
3		230	22.32 (566,9)	53
3	3	230	19.32 (490,7)	47
3		460	19.32 (490,7)	47
5	1	230	28.57 (725,7)	74
5	3	230	22.57 (573,3)	59
5		460	22.57 (573,3)	59
7.5		230	28.57 (725,7)	74
7.5		460	28.57 (725,7)	74
10		460	31.57 (801,9)	80

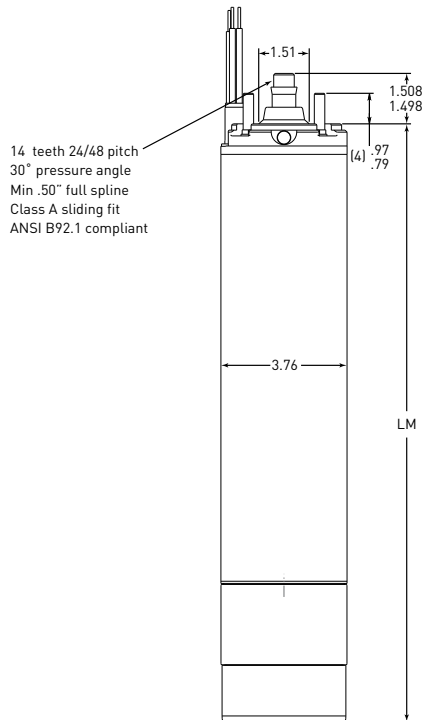

NOTE: Amp ratings on 3-wire motors reflect use with CSIR controls. A CSCR control is recommended for lower values.

Submersible Motor Controls



Pentek® offers a full range of 1/2 - 15 HP models that are interchangeable with existing motor controls for Capacitor Start/Induction Run (CSIR) and Capacitor Start/Capacitor Run (CSCR) applications. Pentek is the professional choice in harsh and high temperature installations.

APPLICATIONS

Water systems...for residential, commercial, multiple housing and farm uses, where a submersible 3-wire motor is used.

FEATURES

ENCLOSURE

Rugged NEMA 3R Enclosure:
Suitable for indoor/outdoor use.

NEW HardBond™ Finish:
5-times more corrosion-resistant.

Multiple-Size Electrical Knockouts

INTERNALS

High-Load Voltage Relay

Heavy-Duty Contacts

External Access to Overload Reset CSCR

Heavy-Duty Terminal Connectors:
Suitable for up to #4 AWG wire.

Industry Standard Wiring Connections:
Easy-to-read wiring diagrams.

Agency Approvals: UL 778 and CUL Recognized (60 Hz)



Submersible Motor Controls

ORDERING INFORMATION

HP	KW	PH	VOLTS	60 HZ CATALOG NUMBER	50 HZ CATALOG NUMBER	WEIGHT		ENCLOSURE SIZE
						LBS.	KG	
CSIR – CAPACITOR START/INDUCTION RUN								
1/2	0.37	1	115	SMC-IR0511 [-6pk]*		4	1.8	A
1/2	0.37	1	230	SMC-IR0521 [-6pk]*		4	1.8	A
3/4	0.55	1	230	SMC-IR0721 [-6pk]*		4	1.8	A
1	0.75	1	230	SMC-IR1021 [-6pk]*		4	1.8	A
CSCR – CAPACITOR START/CAPACITOR RUN								
1/2	0.37	1	230	SMC-CR0521 [-6pk]*	SMC5-CR0521	5	2.3	A
3/4	0.55	1	230	SMC-CR0721 [-6pk]*	SMC5-CR0721	5	2.3	A
1	0.75	1	230	SMC-CR1021 [-6pk]*	SMC5-CR1021	5	2.3	A
1-1/2	1.1	1	230	SMC-CR1521	SMC5-CR1521	7	3.2	B
2	1.5	1	230	SMC-CR2021	SMC5-CR2021	7	3.2	B
3	2.2	1	230	SMC-CR3021	SMC5-CR3021	7	3.2	B
5	3.7	1	230	SMC-CR5021	SMC5-CR5021	8	3.6	B
7-1/2	5.5	1	230	SMC-CR7521		12	5.4	C
10	7.5	1	230	SMC-CR10021		14	6.4	C
CSCR PLUS – CAPACITOR START/CAPACITOR RUN PLUS MAGNETIC CONTACTOR								
2	1.5	1	230	SMC-CRP2021	SMC5-CRP2021	7	3.2	B
3	2.2	1	230	SMC-CRP3021	SMC5-CRP3021	8	3.6	B
5	3.7	1	230	SMC-CRP5021	SMC5-CRP5021	12	5.4	C
7-1/2	5.5	1	230	SMC-CRP7521		14	6.4	C
10	7.5	1	230	SMC-CRP10021		15	6.8	C
15	11	1	230	SMC-CRP15021		17	7.7	C

*Submersible Motor Controls are available in single and six packs. Include the suffix "-6pk" after the catalog number if 6 packs are required.

OUTLINE DIMENSIONS

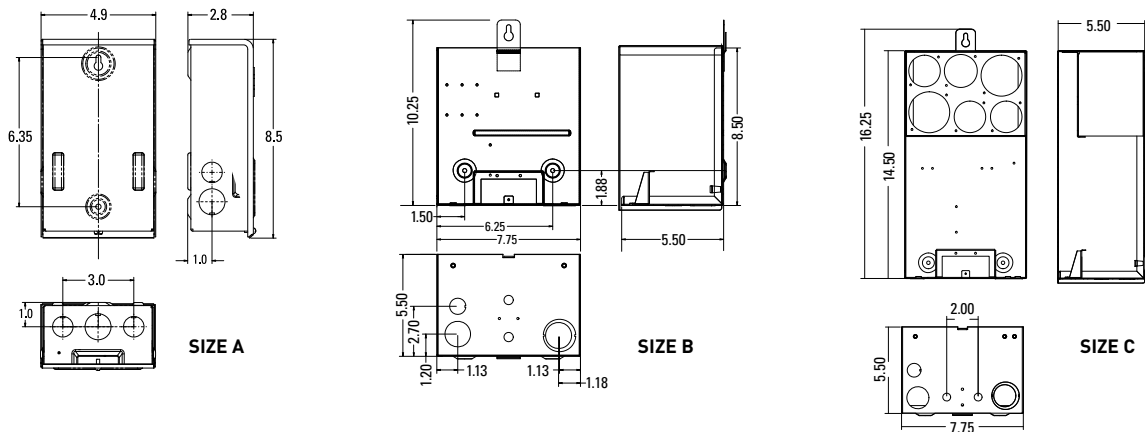

Dimensions (in inches) are for estimating purposes only.

Submersible Motor Controls



Pentek® offers a full range of 1/3 - 15 HP single-phase protectors for residential, commercial, multiple housing and farm water systems applications where a 4" submersible, 2- and 3-wire motor is used and for aboveground pressure-boost applications.

APPLICATIONS

Pentek offers 5 models for your application needs based on HP and Motor Type: SPP-111P, SPP-111-3RLP, SPP-231P, SPP-233P and SPP-235P.

FEATURES

Protects Pumps: From dry well, overcurrent (jammed impeller), flow restriction (dead head), overvoltage, undervoltage, rapid cycling.

ORDERING INFORMATION

	115 VOLT MODELS		230 VOLT MODELS		
Catalog Number	SPP-111P	SPP-111-3RLP	SPP-231P	SPP-233P	SPP-235P
Enclosure Type	Insider	NEMA 3R	Insider	NEMA 3R	NEMA 3R
1-Phase Line Voltage	115VAC	115VAC	230VAC	230VAC	230VAC
Load Range	1/3-1/2 HP	1/3-1 HP	1/2-1 HP	1/2-3 HP	5-15 HP
Frequency	50-60Hz	50-60Hz	50-60Hz	50-60Hz	50-60Hz
Operating Points					
Overload (% of Cal. Point)	125%	125%	125%	125%	125%
Overvoltage Reset Point	132VAC	132VAC	265VAC	265VAC	265VAC
Undervoltage Reset Point	95VAC	95VAC	190VAC	190VAC	190VAC
Trip Delay (Overload)	10 sec.	10 sec.	10 sec.	5 sec.	5 sec.
Trip Delay (Dry Well)	2 sec.	2 sec.	2 sec.	2 sec.	2 sec.
Optional Trip Delay	4 sec.	4 sec.	4 sec.	4 sec.	4 sec.
Restart Delay Time					
Over/Under Voltage Delay	5 sec.	5 sec.	5 sec.	5 sec.	5 sec.
All Other Faults (Dry Well REC. Timer)	2-225 min.	2-225 min.	2-225 min.	2-225 min.	2-225 min.
Output Contact Rating (SPST)	1 HP	1 HP	1 HP (17 amps max.)	3 HP (17 amps max.)	480VA @ 240VAC
Power Consumption (max.)	5 amps	5 amps	5 amps	5 amps	5 amps
Weight w/o Enclosure	10 oz.		10 oz.	14 oz.	14 oz.
Weight w/Enclosure		1.6 lbs.		1.6 lbs.	1.6 lbs.
Enclosure Size	2.2" x 2.8"	6" x 6" x 4"	2.2" x 2.8"	6" x 6" x 4"	6" x 6" x 4"

SPP-111P and SPP-231P The Insider



APPLICATIONS

Water systems...for residential, commercial, multiple housing, farm and turf irrigation uses, where a 4" submersible 3-wire motor is used.

FEATURES

Restart Delay: Can be set up to 225 minutes or placed in manual reset mode.

Calibration: Can be calibrated to specific pump/motor combinations and various conditions.

Infrared Communication: Coupled with the Pentek Informer makes diagnostics simple.

Fits in Existing 3-Wire Motor Control Boxes

For 1/3 - 1 HP applications, the SPP-111P and the SPP-231P Insider fits within 1/3 - 1 HP 115V and 230V CSIR control boxes. It's a "current monitor" designed to protect single-phase pumps. A simple adjustment allows the Insider to be calibrated to your specific pumping applications, reducing the possibility of false or nuisance tripping. Its unique microprocessor constantly monitors the incoming power

for fluctuations in voltage and current. If loss of suction or other abnormality is detected, the Insider deactivates its output relay and directly disconnects the pump motor. Then it begins its user-selectable "Restart Delay/Dry Well Recovery" timer. When the timer counts zero or power is removed and reapplied, the SPP-231P Insider reactivates its output relay and turns the pump back on.

The Pentek® Informer Remote Handheld Diagnostic Tool (sold separately) communicates directly with ALL Pentek Pump Protectors and instantly displays 16 parameters including calibration points, running points and last fault.

ORDERING INFORMATION

HP	PHASE	VOLTS	FREQUENCY	CATALOG NUMBER	WEIGHT		CARTON SIZE
					LBS.	KG	
1/3-1/2	1	115	50-60Hz	SPP-111P	1	0.45	4.4" x 4.4" x 6.8"
1/3-1	1	230	50-60Hz	SPP-231P	1	0.45	4.4" x 4.4" x 6.8"

SPP-111-3RLP, SPP-233P and SPP-235P



SPP-233P



APPLICATIONS

Water systems...for residential, commercial, multiple housing and farm uses, where a 4" 2 or 3-wire submersible motor or aboveground motor is used.

FEATURES

Protects Pumps: From dry well overvoltage, flow restriction (dead head), undervoltage, overcurrent (jammed impeller).

For 1/2 - 15 HP applications the SPP-111-3RLP, SPP-233P and SPP-235P single-phase protectors include a unique microcontroller-based voltage and current-sensing circuit that constantly monitors the incoming power for fluctuations including overcurrent and undercurrent. When an abnormality, such as loss of suction, is detected, the control deactivates its output relay and directly disconnects the pump motor.

The SPP then begins its user-selectable restart delay (dry-well recovery) timer. When the timer counts to zero or power is removed and reapplied, the SPP reactivates its output relay and turns the pump back on. An infrared LED communicates directly with a handheld diagnostic tool called the Informer (sold separately – see page 60). The Informer displays 15 parameters including calibration point, trip point, running points, and last fault. The SPPs are all mounted in a NEMA 3R enclosure.

ORDERING INFORMATION

HP	PHASE	VOLTS	FREQUENCY	CATALOG NUMBER	WEIGHT		CARTON SIZE
					LBS.	KG	
1/2-1	1	115	50-60Hz	SPP-111-3RLP	1.6	0.7	7.25" x 7" x 5.25"
1/2-1-1/2	1	230	50-60Hz	SPP-233P-1.5	1.6	0.7	7.25" x 7" x 5.25"
1/2-3	1	230	50-60Hz	SPP-233P	1.6	0.7	7.25" x 7" x 5.25"
5 and 7-1/2	1	230	50-60Hz	SPP-235P-75*	2	0.9	7.25" x 7" x 5.25"
10	1	230	50-60Hz	SPP-235P-100*	2	0.9	7.25" x 7" x 5.25"
15	1	230	50-60Hz	SPP-235P-150*	2	0.9	7.25" x 7" x 5.25"

*Current transformer included.

The Informer Remote diagnostic



FEATURES

Infrared Receiver: The Pentek® Informer uses an infrared receiver to access data sent from the SPP, allowing remote troubleshooting of the system.

Infrared LED: Each Pentek SPP is equipped with an infrared LED that transmits information from the device. The Informer must be aimed at the SPP as shown in the figure to the left. As soon as power is applied, the Informer begins receiving both past and present information and displays it on the LCD.

Status Light: The green COMM STATUS light indicates when the Informer is receiving data from the SPP. If communication is lost, the Informer will hold the last values it received.

APPLICATIONS

The Pentek® Informer...a remote handheld diagnostic tool designed for use with Pentek single-phase submersible pump protectors (SPP-111P, 231P, 233P and 235P) equipped with infrared LED transmitters.

SPECIFICATIONS

Displayed Parameters: Diagnostic information received and displayed in real time: Voltage, Current, Power, Dry Well.

Overload Trip Points

Calibration Voltage

Last Fault

Highest/Lowest Voltage Since Last Calibration

ORDERING INFORMATION

CATALOG NUMBER	WEIGHT		CARTON SIZE
	LBS.	KG	
SPP-Informer	1	0.45	4.375" x 3.375" x 6.75"

PENTEK Intellidrive™

Water Pressure Control Center



Homeowners with water pressure problems experience weak showers, unclean dishes, dry lawns and more. The Pentek Intellidrive Water Pressure Control Center is an “Intelligent Variable Frequency Drive” that directs changes in submersible pump motor speed, responding to fluctuations in household demand. It maintains constant water pressure, regardless of how many people or appliances are using water at the same time.

APPLICATIONS

Residential water systems, landscape irrigation, water transfer.

SPECIFICATIONS

Enclosure Dimensions:

Width: 9.72” Height: 19” Depth: 6.93”

Carton Dimensions: 10.4” width, 22.3” height, 9.4” depth

Shipping Weight: 22 pounds

Ambient Temperature Range: -20°C (-4°F) to 50°C (122°F)

Ambient Humidity Range: 95% non-condensing

Includes:

Variable Frequency Drive

Transducer: 1/4” thread size, 18 NPT type

Transducer Cable: 10’ length standard

FEATURES

3 MODELS MEET ALL YOUR NEEDS

1-HP, 2-HP & 5-HP Capabilities

2-Wire, 3-Wire & 3-Phase in same unit

3-Phase Output (60 Hz/80 Hz)**

PUMP AND MOTOR LAST LONGER

“Soft Start/Coast to Stop” minimizes mechanical stress.

Constant pressure eliminates frequent on/off “pressure cycling”.

ADVANCED CONTROL SYSTEM

Needed for installation, system monitoring and troubleshooting.

Easy touchpad operation.

GROUND DETECTION

Detects and displays when there is a grounding problem.

Shuts down system until problem is corrected.

60Hz operation is recommended as the industry standard. Intermittent 80Hz operation is an acceptable option. ** Ongoing 80Hz operation may reduce the life of the pump and motor.

ORDERING INFORMATION

MODEL NUMBER	MOTOR TYPE	HP RANGE	INPUT VOLTAGE	MAXIMUM OUTPUT AMPS	ENCLOSURE TYPE				
PID10	2-WIRE* 1-PHASE	0.5-1 HP	190V – 265V	9.5A	NEMA 3R outdoor				
	3-WIRE* 1-PHASE			7.5A					
	3-PHASE			5A					
PID20	2-WIRE* 1-PHASE	0.5-1.5 HP		190V – 265V		11A	NEMA 3R outdoor		
	3-WIRE* 1-PHASE	0.5-2 HP				13.5A			
	3-PHASE					8.5A			
PID50	2-WIRE* 1-PHASE	0.5-1.5 HP				190V – 265V		11A	NEMA 3R outdoor
	3-WIRE* 1-PHASE	0.5 – 2 HP						13.5A	
	3-PHASE	0.5 – 5 HP						18A	

PENTEK Intellidrive™

Water Pressure Control Center

Keyhole Mount

For fast and easy installation

LCD Information Center

Displays installation, status and fault information in easy-to-understand language instead of codes

Ground Detection

Message Center shows if there is a grounding problem

Multiple Accessory Inputs

Additional inputs allow use of multiple drive accessories at the same time

Best-In-Class EMI/RFI Filter

Superior noise and interference protection, including AM radio signals

Spacious Wiring Area

For fast and easy installation

Programmable Input/Output Relays

Provide application flexibility

Easy-Access Conduit Openings

Align with appropriate terminals for straight-in accessibility. Fits 1/2", 3/4" or 1-1/4"

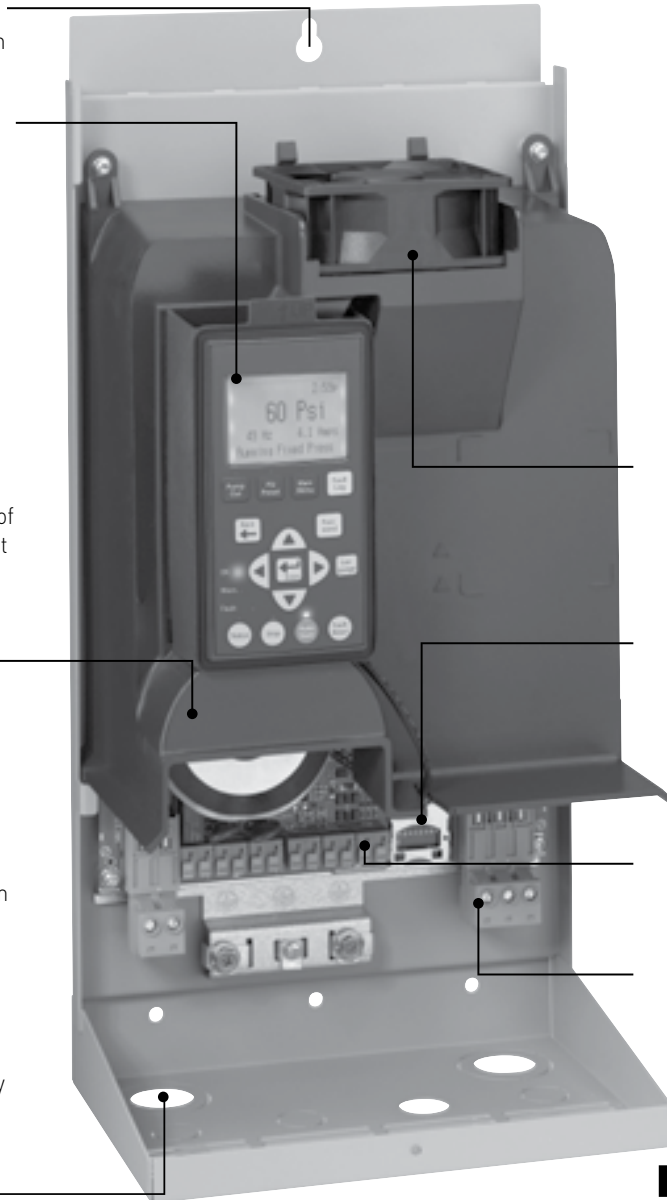

Electronic Pressure Transducer

More accurate and reliable than mechanical pressure switch, with piezo resistive technology designed to resist water hammer

Temperature- Sensitive Intelligent Fan

Operates when needed for quiet operation

SD Card Slot

For easy software updates when provided by manufacturer

Spring Terminals

For secure connections and easy installation without special tools

Removable Terminal Blocks

For easy wiring of motor and power supply – field replaceable

OUTLINE DIMENSIONS

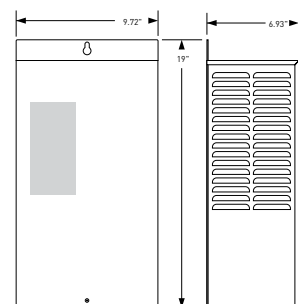

Dimensions (in inches) are for estimating purposes only.

PENTEK Intellikit™

Constant Pressure Controller

Pre-Specified and Packaged Constant Pressure Systems for Residential Well Water

Maintain constant water pressure for submersible well pump systems, similar to municipal water systems



1

PENTEK

Submersible Motor

Built with the latest design, manufacturing and testing technology

Encapsulated stainless steel design and professional-grade insulation provide longer life in harsh environments

100% factory pressure- and run-tested

2

STA-RITE

Submersible Pump

Submersible pumps deliver efficient and dependable performance even in rough, aggressive water

One of the few manufacturers of both pumps and pressurized water storage tanks, now sold in over 100 countries

3

PENTEK INTELLIDRIVE

Variable Frequency Drive

Maintains constant pressure output regardless of fluctuating demand

Extends life of pump and motor

Utilizes a smaller pressure tank for a space-saving solution

KIT CONTAINS:

- Pentek® Submersible Motor
- Sta-Rite® Submersible Pump
- Pentek Intellidrive™ Variable Frequency Drive

The Pentek Intellidrive Constant Pressure Controller automatically adjusts motor speeds to meet changes in water demand. Instantaneous feedback from an electronic pressure transducer instructs the drive to change the submersible well pump motor speed to maintain constant pressure throughout the system.

PENTEK Intellikit™

ORDERING INFORMATION

60Hz NEMA 3 Kits

Order Number	Flow Series	HP	Shut-Off Head	At Rated Flow	at Max Runout		Pump	Drive	Motor
			TDH (ft)	TDH (ft)	Flow (GPM)	TDH (ft)			
S5PIK10-60	5	1HP	650	475	7	300	L5P4EHL	PID10	P43B0010A3-C
S5PIK15-60	5	1.5HP	885	640	7	400	L5P4FHL	PI D20	P43B0015A3-C
S7PIK10-60	7	1HP	540	380	10	140	L7P4EHL	PID10	P43B0010A3-C
S7PIK15-60	7	1.5HP	740	475	10	190	L7P4FHL	PID20	P43B0015A3-C
S7PIK20-60	7	2HP	920	610	10	210	L7P4GHL	PID20	P43B0020A3-C
S10PIK10-60	10	1HP	495	300	15	110	L10P4EH	PID10	P43B0010A3-C
S10PIK15-60	10	1.5HP	629	410	15	150	L10P4FH	PID20	P43B0015A3-C
S10PIK20-60	10	2HP	795	498	15	200	L10P4GH	PID20	P43B0020A3-C
S10PIK30-60	10	3HP	1100	710	15	250	L10P4HH	PID50	P43B0030A3-C
S15PIK10-60	15	1HP	310	200	21	95	L15P4EH	PID10	P43B0010A3-C
S15PIK15-60	15	1.5HP	420	280	21	120	L15P4FH	PID20	P43B0015A3-C
S15PIK20-60	15	2.0HP	522	350	21	150	L15P4GH	PID20	P43B0020A3-C
S15PIK30-60	15	3.0HP	770	520	21	230	L15P4HH	PID50	P43B0030A3-C
S20PIK10-60	20	1HP	250	185	28	80	L20P4EH	PID10	P43B0010A3-C
S20PIK15-60	20	1.5HP	335	232	28	110	L20P4FH	PID20	P43B0015A3-C
S20PIK20-60	20	2.0HP	420	310	28	150	L20P4GH	PID20	P43B0020A3-C
S20PIK30-60	20	3.0HP	640	460	28	200	L20P4HH	PID50	P43B0030A3-C
S30PIK20-60	30	2.0HP	275	195	42	85	L30P4GH	PID20	P43B0020A3-C
S30PIK30-60	30	3.0HP	410	295	42	120	L30P4HH	PID50	P43B0030A3-C
S50PIK20-60	50	2.0HP	180	119	63	80	L50P4GH	PID20	P43B0020A3-C
S50PIK30-60	50	3.0HP	240	162	63	110	L50P4HH	PID50	P43B0030A3-C
S90PIK20-60	90	2.0HP	109	58	120	40	L90HF20	PID20	P43B0020A3-C
S90PIK30-60	90	3.0HP	150	80	120	55	L90HF30	PID50	P43B0030A3-C

80Hz NEMA 3 Kits

S7PIK15-80	7	1.5HP	740	475	10	190	L7P4DHL	PID20	P43B0015A3-C
S7PIK20-80	7	2HP	920	610	10	210	L7P4EHL	PID20	P43B0020A3-C
S7PIK30-80	7	3HP	1205	805	10	290	L7P4FHL	PID50	P43B0030A3-C
S10PIK15-80	10	1.5HP	629	410	15	150	L10P4DH	PID20	P43B0015A3-C
S10PIK20-80	10	2HP	795	498	15	200	L10P4EH	PID20	P43B0020A3-C
S10PIK30-80	10	3HP	1100	710	15	250	L10P4FH	PID50	P43B0030A3-C
S15PIK15-80	15	1.5HP	420	280	21	120	L15P4DH	PID20	P43B0015A3-C
S15PIK20-80	15	2.0HP	522	350	21	150	L15P4EH	PID20	P43B0020A3-C
S15PIK30-80	15	3.0HP	770	520	21	230	L15P4FH	PID50	P43B0030A3-C
S20PIK15-80	20	1.5HP	335	232	28	110	L20P4DH	PID20	P43B0015A3-C
S20PIK20-80	20	2.0HP	420	310	28	150	L20P4EH	PID20	P43B0020A3-C
S20PIK30-80	20	3.0HP	640	460	28	200	L20P4FH	PID50	P43B0030A3-C
S30PIK20-80	30	2.0HP	275	195	42	85	L30P4EH	PID20	P43B0020A3-C
S30PIK30-80	30	3.0HP	410	295	42	120	L30P4FH	PID50	P43B0030A3-C
S50PIK30-80	50	3.0HP	240	162	63	110	L50P4FH	PID50	P43B0030A3-C
S90PIK30-80	90	3.0HP	150	80	120	55	L90HF20	PID50	P43B0030A3-C

Note:

80Hz Kits utilize an undersized liquid end running at higher speed to match pump performance of the curve equivalent to the driving motor. Maximum life expectancy of the liquid end is obtained using 60Hz solutions.

PENTEK® PPC3 and PPC5 Pump Controllers



Pentek Pump Controllers provide innovative pumping solutions for maximizing pump functionality, optimizing pump system design and reducing operating energy costs.

Pentek PPCs can be used on all centrifugal motor-driven pumps including close-coupled motor drive, frame mount, submersible and line shaft turbine pumps, in a wide range of applications.

APPLICATIONS

Turf irrigation, water transfer, light commercial water systems and agricultural.

SPECIFICATIONS

- HP Ratings:**
PPC3: 1 - 30; PPC5: 1/2 - 200
- Voltage:**
PPC3: 230, 460; PPC5: 230, 460, 575
- Frequency:** 50/60 Hz
- Floating Choke:** PPC5 only
- Harmonic Signature:**
PPC3: Good; PPC5: Best
- Number of Relays:**
PPC3: 1; PPC5: 3 (ext. to 6 available)
- Digital Inputs:** PPC3: 5; PPC5: 6
- Multiple Pump Capable:** PPC5 only
- Mod. Bus:** PPC5 only
- Enclosure Type:**
PPC3: NEMA 1; PPC5: NEMA 1, 12

NOTE: The output current (or amps) of the PPC must be greater than or equal to the maximum rated motor current.

FEATURES

PPC Controller

Variable Speed Control: Meets requirements of process control with constant pressure at variable flow conditions or constant flow at variable pressure conditions.

Reduced Energy Costs: Calculate energy savings online using BEC2 software at www.bec2.net.

Pump Protection: From loss of prime, dead head and blocked suction.

Motor Protection: From ground fault, short circuit, phase loss and imbalance, overload, undervoltage and overvoltage.

System Protection (PPC5 only): From harmonics, featuring an input choke that exceeds the performance of a fixed 5% impedance line reactor.

Phase Conversion: The PPC5 will convert 1-phase power into 3-phase power, allowing the use of a 3-phase motor; the PPC3 is available in both 1- and 3-phase models.

Pentek Assistant

Auto-Restart Functionality: Re-starts pump after power loss.

Easily Configured for Constant Flow Applications: By adjusting 2 additional menu parameters.

Multiple System Setpoints or Operating Condition: Includes two independent process control setpoints to allow operation under a second process.

Time Function: Supports 4 daily and weekly Start/Stop/Boost times.

PENTEK® PPC3 and PPC5 Pump Controllers

ORDERING INFORMATION

PPC3 200-240 VOLT – 1-PHASE IN, 3-PHASE OUT

OUTPUT AMPS	ENCLOSURE SIZE	MOUNTING	MODEL NUMBER NEMA 1
4.7	R1	WALL	PPC3-1-4A7-1
6.7	R1	WALL	PPC3-1-6A7-1
7.5	R2	WALL	PPC3-1-7A5-1
9.8	R2	WALL	PPC3-1-9A8-1

PPC3 200-240 VOLT – 3-PHASE IN, 3-PHASE OUT

OUTPUT AMPS	ENCLOSURE SIZE	MOUNTING	MODEL NUMBER NEMA 1
4.7	R1	WALL	PPC3-2-4A7-1
6.7	R1	WALL	PPC3-2-6A7-1
7.5	R1	WALL	PPC3-2-7A5-1
9.8	R2	WALL	PPC3-2-9A8-1
17.6	R2	WALL	PPC3-2-17A6-1
24.4	R3	WALL	PPC3-2-24A4-1
31.0	R4	WALL	PPC3-2-31A0-1
46.2	R4	WALL	PPC3-2-46A2-1

PPC3 380-480 VOLT – 3-PHASE IN, 3-PHASE OUT

OUTPUT AMPS	ENCLOSURE SIZE	MOUNTING	MODEL NUMBER NEMA 1
2.4	R1	WALL	PPC3-4-2A4-1
3.3	R1	WALL	PPC3-4-3A3-1
4.1	R1	WALL	PPC3-4-4A1-1
5.6	R1	WALL	PPC3-4-5A6-1
8.8	R1	WALL	PPC3-4-8A8-1
12.5	R3	WALL	PPC3-4-12A5-1
15.6	R3	WALL	PPC3-4-15A6-1
23.1	R3	WALL	PPC3-4-23A1-1
31.0	R4	WALL	PPC3-4-31A0-1
38.0	R4	WALL	PPC3-4-38A0-1
44.0	R4	WALL	PPC3-4-44A0-1

ORDERING INFORMATION

PPC5 208-240 VOLT – 3-PHASE IN, 3-PHASE OUT

OUTPUT AMPS	ENCLOSURE SIZE	MOUNTING	MODEL NUMBER NEMA 1	MODEL NUMBER NEMA 12
4.6	R1	WALL	PPC5-2-4A6-1	PPC5-2-4A6-12
6.6	R1	WALL	PPC5-2-6A6-1	PPC5-2-6A6-12
7.5	R1	WALL	PPC5-2-7A5-1	PPC5-2-7A5-12
11.8	R1	WALL	PPC5-2-11A-1	PPC5-2-11A-12
16.7	R1	WALL	PPC5-2-16A-1	PPC5-2-16A-12
24.2	R2	WALL	PPC5-2-24A-1	PPC5-2-24A-12
30.8	R2	WALL	PPC5-2-30A-1	PPC5-2-30A-12
46.2	R3	WALL	PPC5-2-46A-1	PPC5-2-46A-12
59.4	R3	WALL	PPC5-2-59A-1	PPC5-2-59A-12
74.8	R4	WALL	PPC5-2-74A-1	PPC5-2-74A-12
88	R4	WALL	PPC5-2-88A-1	PPC5-2-88A-12
114	R4	WALL	PPC5-2-114A-1	PPC5-2-114A-12
143	R6	WALL	PPC5-2-143A-1	—
178	R6	WALL	PPC5-2-178A-1	—
221	R6	WALL	PPC5-2-221A-1	—
248	R6	WALL	PPC5-2-248A-1	—

PPC5 400-480 VOLT – 3-PHASE IN, 3-PHASE OUT

OUTPUT AMPS	ENCLOSURE SIZE	MOUNTING	MODEL NUMBER NEMA 1	MODEL NUMBER NEMA 12
3.3	R1	WALL	PPC5-4-3A3-1	PPC5-4-3A3-12
4.1	R1	WALL	PPC5-4-4A1-1	PPC5-4-4A1-12
6.9	R1	WALL	PPC5-4-6A9-1	PPC5-4-6A9-12
8.8	R1	WALL	PPC5-4-8A8-1	PPC5-4-8A8-12
11.9	R1	WALL	PPC5-4-11A-1	PPC5-4-11A-12
15.4	R2	WALL	PPC5-4-15A-1	PPC5-4-15A-12
23	R2	WALL	PPC5-4-23A-1	PPC5-4-23A-12
31	R3	WALL	PPC5-4-31A-1	PPC5-4-31A-12
38	R3	WALL	PPC5-4-38A-1	PPC5-4-38A-12
44	R4	WALL	PPC5-4-44A-1	PPC5-4-44A-12
59	R4	WALL	PPC5-4-59A-1	PPC5-4-59A-12
72	R4	WALL	PPC5-4-72A-1	PPC5-4-72A-12
77	R5	WALL	PPC5-4-77A-1	PPC5-4-77A-12
96	R5	WALL	PPC5-4-96A-1	PPC5-4-96A-12
124	R6	WALL	PPC5-4-124A-1	—
157	R6	WALL	PPC5-4-157A-1	—
180	R6	WALL	PPC5-4-180A-1	—
196	R7	FLOOR	PPC5-4-196A-1	—
245	R7	FLOOR	PPC5-4-245A-1	—

PPC5 500-600 VOLT – 3-PHASE IN, 3-PHASE OUT

OUTPUT AMPS	ENCLOSURE SIZE	MOUNTING	MODEL NUMBER NEMA 1	MODEL NUMBER NEMA 12
2.7	R1	WALL	PPC5-5-2A7-1	PPC5-5-2A7-12
3.9	R1	WALL	PPC5-5-3A9-1	PPC5-5-3A9-12
6.1	R1	WALL	PPC5-5-6A1-1	PPC5-5-6A1-12
9	R1	WALL	PPC5-5-9A0-1	PPC5-5-9A0-12
11	R1	WALL	PPC5-5-11A-1	PPC5-5-11A-12
17	R2	WALL	PPC5-5-17A-1	PPC5-5-17A-12
22	R2	WALL	PPC5-5-22A-1	PPC5-5-22A-12
27	R3	WALL	PPC5-5-27A-1	PPC5-5-27A-12
32	R3	WALL	PPC5-5-32A-1	PPC5-5-32A-12
41	R4	WALL	PPC5-5-41A-1	PPC5-5-41A-12
52	R4	WALL	PPC5-5-52A-1	PPC5-5-52A-12
62	R4	WALL	PPC5-5-62A-1	PPC5-5-62A-12
77	R5	WALL	PPC5-5-77A-1	PPC5-5-77A-12
99	R6	WALL	PPC5-5-99A-1	PPC5-5-99A-12

NOTE: The output current (or amps) of the PPC must be greater than or equal to the maximum rated motor current.

Specifications are based on a 3-phase supply voltage, 208 volt or 230 volt. For operation on 1-phase input power, de-rate the drive output current by 50%. Drive output is always 3-phase voltage.

Hitachi® 6" Submersible Motors

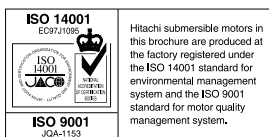

Hitachi Motors are designed for long service life and years of dependable operation. Innovative design and robust characteristics make this the perfect motor for your pumping applications.

Combined with exceptional insulation and a patented epoxy fill resin, these motors exceed NEMA requirements for high water temperature by 18°F (10°C). Designed with internal lubrication and cooling blend of water, antifreeze, and an antirust mixture, Hitachi submersible motors are unique in providing the industry with innovative and robust design features that will extend the serviceable life of your installation.

APPLICATIONS

High-thrust water well applications.

SPECIFICATIONS

- Motor Sleeve:** Stainless steel construction
- Castings:** Baked epoxy-coated gray iron
- Fasteners:** Stainless steel
- Shaft:** NEMA splined stainless steel
- Flange:** NEMA standard type
- Rotor:** Double epoxy-coated
- Thrust Bearings:** Kingsbury-type 420 stainless steel
- Mechanical Seal:** Nitrile rubber (NBR), grease packed
- Diaphragm:** Nitrile rubber
- Sand Cap:** Polyurethane
- Sand Slinger:** Stainless steel
- Lead Wire (or Cable):** Double-insulated, heat and water-resistant, 167°F/75°C, 600V

FEATURES

- Higher Efficiencies and Lower Current Consumption:** For reduced energy costs.
- Corrosion-Resistant Design:** For long life.
- High-Capacity Kingsbury-Type Bearings:** For dependable performance.
- Low-Profile NEMA Design:** For ease of installation.
- Replaceable Plug-in Motor Lead:** For ease of maintenance.
- Dual Voltage Type:** For application versatility (5 HP – 30 HP 3-Phase Motors).
- VFD-Compatible**

Hitachi Control Box

- Type 1 NEMA Enclosure
- In-Panel Circuit Breaker
- Magnetic Contactor
- Terminal Blocks for External Controls
- UL Recognized



Hitachi® is a registered trademark of Hitachi Industrial Equipment Systems Co., Ltd. All other brand or product names are trademarks or registered trademarks of Pentair Ltd.

Hitachi® 6" Submersible Motors

ORDERING INFORMATION

HP	KW	VOLTS	PH	SERVICE FACTOR	CATALOG NUMBER	RATED INPUT AMPS	SERVICE FACTOR INPUT AMPS	WINDING RESISTANCE (OHMS)	THRUST CAPACITY	LENGTH (L)		DIAMETER (D)		WEIGHT	
										IN.	MM	IN.	MM	LBS.	KG
6" DIAMETER 60 HZ															
5	3.7	200	3	1.15	6HIT2-5-8	17.5	19.5		3,500	22.95"	582.9	5.5"	139.7	95	43.0
5	3.7	230	1	1.15	6HIT2-5-1	24	27.5	R-Y, B-Y, R-B, 2.172, 0.512, 2.627	3,500	26.97"	685.0	5.5"	139.7	110	49.9
5	3.7	230	3	1.15	6HIT2-5-2	15	17	0.806	3,500	22.95"	582.9	5.5"	139.7	95	43.0
5	3.7	460	3	1.15	6HIT2-5-4	7.5	8.5	3.05	3,500	22.95"	582.9	5.5"	139.7	95	43.0
7.5	5.5	200	3	1.15	6HIT2-7-8	25.4	28.5		3,500	24.80"	629.9	5.5"	139.7	99	43.0
7.5	5.5	230	1	1.15	6HIT2-7-1	36	41	R-Y, B-Y, R-B, 1.401, 0.400, 1.774	3,500	29.92"	760.0	5.5"	139.7	128	58.1
7.5	5.5	230	3	1.15	6HIT2-7-2	22	26	0.651	3,500	24.80"	629.9	5.5"	139.7	99	43.0
7.5	5.5	460	3	1.15	6HIT2-7-4	11	13	2.43	3,500	24.80"	629.9	5.5"	139.7	99	43.0
10	7.5	200	3	1.15	6HIT2-10-8	33.3	37.2		3,500	26.97"	685.0	5.5"	139.7	110	49.9
10	7.5	230	1	1.15	6HIT2-10-1	50	58	R-Y, B-Y, R-B, 1.052, 0.316, 1.310	3,500	29.92"	760.0	5.5"	139.7	128	58.1
10	7.5	230	3	1.15	6HIT2-10-2	29	33	0.448	3,500	26.97"	685.0	5.5"	139.7	110	49.9
10	7.5	460	3	1.15	6HIT2-10-4	14.5	16.5	1.619	3,500	26.97"	685.0	5.5"	139.7	110	49.9
15	11	200	3	1.15	6HIT2-15-8	47.4	53.5		3,500	29.92"	760.0	5.5"	139.7	128	58.1
15	11	230	1	1.15	6HIT2-15-1	72	85	R-Y, B-Y, R-B, 0.678, 0.230, 0.850	3,500	33.46"	849.9	5.5"	139.7	148	67.1
15	11	230	3	1.15	6HIT2-15-2	42	46	0.312	3,500	29.92"	760.0	5.5"	139.7	128	58.1
15	11	460	3	1.15	6HIT2-15-4	21	23	1.074	3,500	29.92"	760.0	5.5"	139.7	128	58.1
20	15	200	3	1.15	6HIT2-20-8	61.2	69.5		3,500	31.5"	800.1	5.5"	139.7	137	62.1
20	15	230	3	1.15	6HIT2-20-2	54	60	0.258	3,500	31.5"	800.1	5.5"	139.7	137	62.1
20	15	460	3	1.15	6HIT2-20-4	27	30	0.861	3,500	31.5"	800.1	5.5"	139.7	137	62.1
25	18.5	200	3	1.15	6HIT2-25-8	77.3	87.5		3,500	36.22"	920.0	5.5"	139.7	161	73.0
25	18.5	230	3	1.15	6HIT2-25-2	68	76	0.21	3,500	36.22"	920.0	5.5"	139.7	161	73.0
25	18.5	460	3	1.15	6HIT2-25-4	34	38	0.666	3,500	36.22"	920.0	5.5"	139.7	161	73.0
30	22	200	3	1.15	6HIT2-30-8	91.8	104		3,500	38.19"	970.0	5.5"	139.7	176	79.8
30	22	230	3	1.15	6HIT2-30-2	82	94	0.166	3,500	39.19"	970.0	5.5"	139.7	176	79.8
30	22	460	3	1.15	6HIT2-30-4	41	47	0.554	3,500	38.19"	970.0	5.5"	139.7	176	79.8
40	30	460	3	1.15	6HIT2-40-4	56	61	0.358	5,000	40.55"	1,030.0	5.5"	139.7	187	84.8
8" DIAMETER 60 HZ															
50	37	460	3	1.15	86HIT2-50-4*	65	73	0.331	5,000	45.28"	1,150.0	7.52"	191.0	353	160.1
60	45	460	3	1.15	86HIT2-60-4*	80	90	0.278	5,000	48.03"	1,220.0	7.52"	191.0	408	185.1

NOTE: 6" motors are 3450 rpm, 60 Hz, 1.15 SF.

See pages 154-157 for Cable Selection Guides.

*8" motor with 6" pump connection

OUTLINE DIMENSIONS

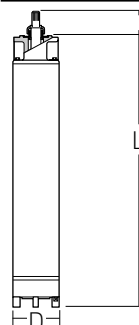

Shaft Extension
2.87" (72.9 mm)

For lengths, refer to Ordering Information tables.

Dimensions are for estimating purposes only.

Single phase motors require a control box.

ORDERING INFORMATION

HP	KW	VOLTS	PH	CATALOG NUMBER
HITACHI CONTROL BOX				
5	3.7	230	1	HIT-5CBD
7.5	5.5	230	1	HIT-7.5CBD
10	7.5	230	1	HIT-10CBD
15	11	230	1	HIT-15CBD

PENTEK® 6" Submersible Motors



Pentek® motors are designed for long service life and years of dependable operation. Innovative design and robust characteristics make this the perfect motor for your pumping applications.

Combining internal lubrication, a cooling blend of water, glycol, and propylene, and superior materials, Pentek submersible motors provide the industry with innovative and advanced design features that will extend the serviceable life of your installation.

APPLICATIONS

High-thrust water well applications.

SPECIFICATIONS

Motor sleeve, fasteners – 304 stainless steel

Castings – cast iron - epoxy electrodisposition coating

Shaft – NEMA splined, 431 stainless steel

Thrust bearings – Kingsbury-type disc - carbon (resin impregnated) pad - 420 stainless steel

Mechanical seal – silicon carbide

Diaphragm, sand slinger – nitrile rubber

FEATURES

Exceptional insulation / temperature rating – exceeds NEMA requirements for high water temperature by 18°F (10°C).

Higher efficiencies and lower current consumption – for reduced energy costs

High-capacity Kingsbury-type bearings – for dependable performance

Superior materials / corrosion-resistant design – for extended life

Sand slinger protection / silicon-carbide mechanical seal / pressure-equalizing diaphragm – advanced design features for superior performance, reliability, and quality

VFD-compatible

PENTEK® 6" Submersible Motors

ORDERING INFORMATION

MOTOR TYPE	PHASE	NOTE	PENTEK MODEL #	HP	KW	HZ	VOLTS	SERVICE FACTOR 1.00			SERVICE FACTOR 1.15			LOCKED ROTOR AMPS	THRUST LOAD	KVA CODE	INSULATION CLASS	WINDING RESISTANCE (OHM)	RPM	LENGTH		WEIGHT							
								AMPS	EFF. %	P.F. %	AMPS	EFF. %	P.F. %							IN	MM	LBS	KG						
6"	Three	Motors are 60 Hz only	6PM2-5-2	5	4	60	230	15.2	75	83	16.4	77	85	102.1	1763	K	F	0.7873	3460	22.7	577	90	41						
			6PM2-7-2	7-1/2	6			21.2	79	85	23.2	79	86	146.4				0.5389	3460	24.9	632	102	46						
			6PM2-10-2	10	8			30.8	77	81	33.0	78	83	187.6				0.3964	3440	29.2	741.5	116	53						
			6PM2-15-2	15	11			43.2	78	84	47.0	78	86	281.8				0.2782	3450	31.8	807.5	121	55						
			6MP2-20-2	20	15			57.4	79	85	63.0	79	87	394.5				0.2101	3450	35.1	892.5	147	67						
			6PM2-25-2	25	19			69	81	86	76.0	80	88	480.2				0.1605	3450	38.0	964.5	165	75						
			6PM2-30-2	30	22			76.6	84	88	85.0	84	89	614.2				0.1445	3500	41.8	1,060.5	190	86						
			Motors are dual rated 50 Hz & 60 Hz	6PM2-5-4	5			4	50	380	8.9	75	87							45.6	1763	K	F	2.9674	2820	22.7	577	90	41
									60	460	10.6	75	83	8.2				77	85	51.1					3460				
				6PM2-7-4	7-1/2			6	50	380	12.5	79	87							66.8	1763	J	F	1.9828	2820	24.9	632	102	46
									60	460	15.4	79	85	11.6				79	86	73.2					3460				
				6PM2-10-4	10			8	50	380	17.8	78	85							85.6	3485	J	F	1.4648	2800	29.2	741.5	116	53
		60				460	15.4		77	81	16.5	78	83	93.8	3440														
		6PM2-15-4	15	11	50	380	25.6	77	87				127	3485	J	F	0.9916	2810	31.8	807.5	131	55							
					60	460	21.6	78	84	23.5	78	86	140.9					3450											
		6PM2-20-4	20	15	50	380	34	78	89				170.2	3485	J	F	0.7192	2810	35.1	892.5	147	67							
					60	460	28.5	79	85	31.5	79	87	197.3					3450											
		6MP2-25-4	25	19	50	380	41	79	89				219	3485	J	F	0.5640	2820	38.0	964.5	165	75							
					60	460	34.5	81	86	38.0	80	88	240.1					3450											
		6PM2-30-4	30	22	50	380	46	83	90				276.8	3485	K	F	0.5036	2880	41.8	1060.5	190	86							
					60	460	38	84	88	42.5	84	89	307.1					3500											
		6PM2-40-4	40	30	50	380	62.5	83	90				393.1	6182	K	F	0.3958	2860	47.1	1197	209	95							
					60	460	52.7	84	88	58.0	84	89	439.7					3490											
		6PM2-50-4	50	37	50	380	77.6	83	90				449.8	6182	K	F	.3295	2840	49.9	1267	292	132							
60	460				64.3	85	87	70.8	85	89	500.5	3480																	

See pages 158-159 for Cable Selection Guides.

OUTLINE DIMENSIONS

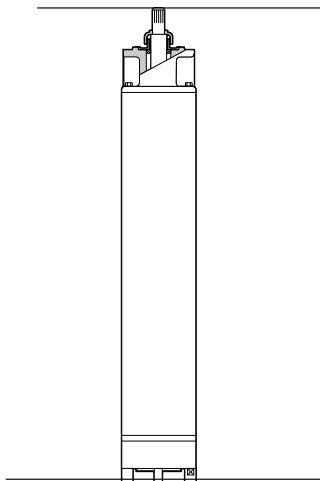

Nominal diameter 6"/152.4 mm
 Effective diameter 5.43"/138 mm
 Shaft extension length 2.87" / 73 mm

For lengths, refer to Ordering Information tables.
 Dimensions are for estimating purposes only.

CJ Series Self-priming shallow well jet pumps

Stainless Steel Body



ClearJet models provide excellent performance with good pressure for wells to 25' deep. Self-priming after the priming chamber has been filled with water.

APPLICATIONS

Water systems and sprinkling... for homes, farms and cottages.

SPECIFICATIONS

Maximum Liquid Temperature Limits: 122°F (50°C)

Max. Inlet Pressure: 50 PSI

Average Priming Time at 20 Feet:

CJ90E = 5.3 min.

CJ90F = 4.2 min.

Body: 304 Stainless steel

Jet Assembly, Diffuser, Impeller: Noryl®

Shaft: One-piece threaded, 416 grade stainless steel

Base: Polypropylene

FEATURES

Corrosion Free: Stainless steel pump body provides maximum resistance to corrosion.

Built-in Jet: High-strength thermoplastic components are corrosion resistant.

Mechanical Shaft Seal: Highly polished carbon-ceramic and stainless steel construction.

Motor Windings: Superior insulation materials protect against excessive moisture and contaminants... assure prolonged motor life.

Balanced Rotor: Diecast under high pressures for uniform performance and greater efficiency, dynamically balanced.

Heavy-Duty Ball Bearings: Shielded, permanently lubricated bearings, extensively tested to ensure extended life and smooth, quiet operation.

Pump and Motor Shaft: Stainless steel for maximum corrosion resistance; one-piece threaded shaft for positive impeller drive and alignment.

Dustproof Cover: All electrical components are protected from dirt, dust and insects by a dustproof canopy; ventilating air cannot contaminate vital switching components.

Pressure Switch: Quality, fixed differential (20 PSI).

ORDERING INFORMATION

CATALOG NUMBER	HP	SWITCH SETTING	DESCRIPTION	PIPE TAPPING SIZES		MOTOR VOLTAGE	APPROX. WT. LBS.
				SUCTION	DISCHARGE		
CJ90E	1	30-50	Shallow Well Jet	1-1/4"	1"	115/230	26
CJ90F	1-1/2	40-60	Shallow Well Jet	1-1/4"	1"	115/230	29

Noryl® is a registered trademark of General Electric Co.
All other brand or product names are trademarks or registered trademarks of Pentair Ltd.

CJ Series Self-priming shallow well jet pumps

Stainless Steel

OUTLINE DIMENSIONS

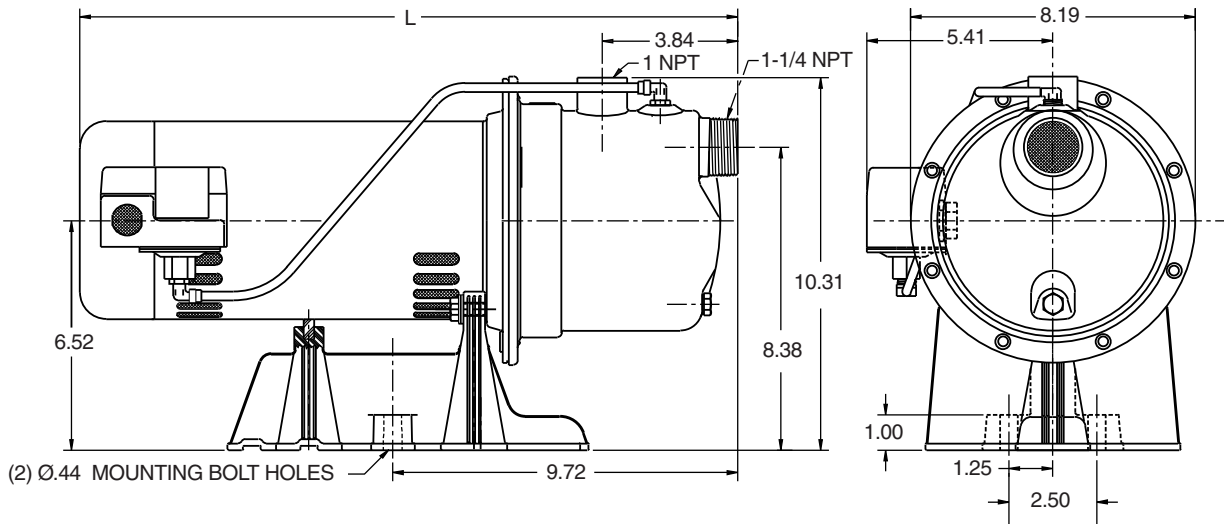

CATALOG NUMBER	L
CJ9E	18.19
CJ90F	19.25

Dimensions (in inches) are for estimating purposes only.

PUMP PERFORMANCE

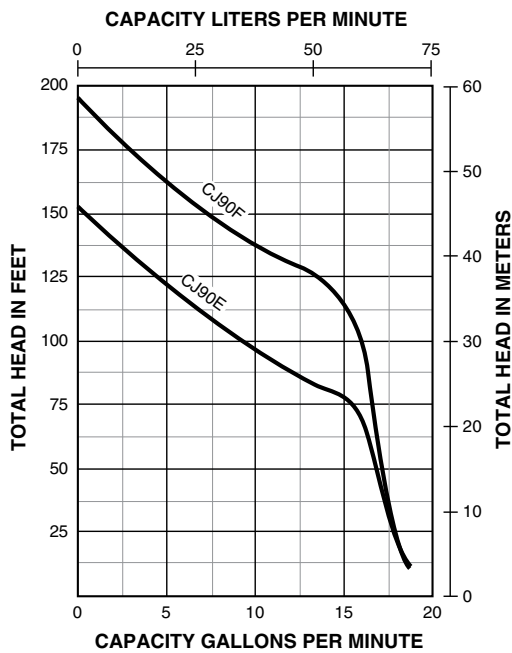

2.31 FT. OF HEAD = 1 PSI
1 FT. OF HEAD = .433 PSI

PUMP PERFORMANCE (CAPACITY IN GALLONS PER MINUTE)

CATALOG NUMBER	HP	DISCH. PRESSURE PSI	DEPTH TO WATER					SHUT-OFF PRESSURE PSI
			5'	10'	15'	20'	25'	
CJ90E	1	30	16.1	14.4	12.6	10.1	7.5	64
		40	11	11	11	9.0	7.2	
		50	5.8	5.8	5.8	5.8	5.8	
CJ90F	1-1/2	40	16.2	14.6	12.6	10.6	7.5	80
		50	15.4	14.3	12.3	10.3	7.3	
		60	9.5	9.5	9.5	9.5	7.1	

Tested and rated in accordance with Water Systems Council Standards.

NOTE: CJ90E used 30-50 PSI pressure switch; CJ90F used 40-60 PSI pressure switch.

Pumps installed with a Pro-Source® tank require a 100 PSI relief valve. Pumps installed with a conventional tank require a 75 PSI relief valve. Relief valve must be capable of relieving entire flow of pump at relief pressure.

ProJet™ HN Series Self-priming shallow well jet pumps

Cast Iron

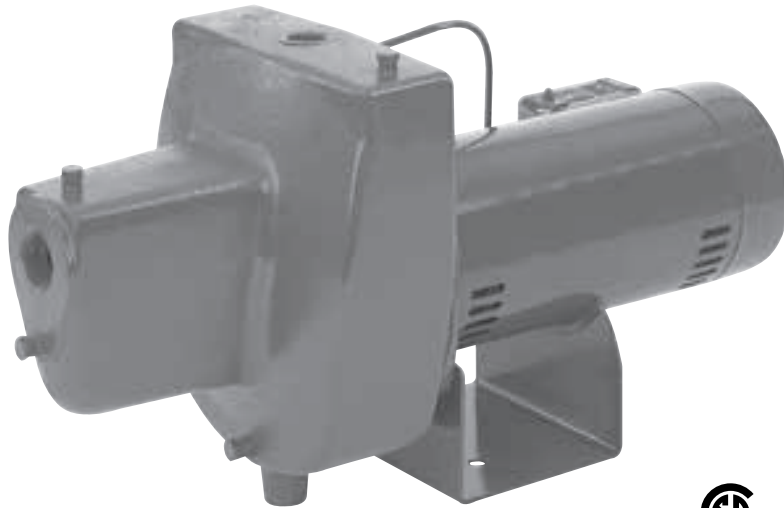

The ProJet HN models provide excellent performance with good pressure for wells to 25' deep. Self-priming after the priming chamber has been filled with water.

APPLICATIONS

Water systems and sprinkling... for homes, farms and cottages.

SPECIFICATIONS

Max. Liquid Temperature: 140°F

Max. Inlet Pressure: 50 PSI

Average Priming Time (in minutes) at 15 Feet:

HNC = 1.7; HND = 1.1; HNE = 1.3

Average Priming Time (in minutes) at 25 Feet:

HNC = 4.4; HND = 4.4; HNE = 2.6

Body: Close-grained cast iron

Nozzle: High-strength Lexan®

Venturi: Lexan®

Impeller: Noryl®

Diffuser: Reinforced polypropylene

Shaft: One-piece threaded, 416 grade stainless steel

Base: Steel, 12 gauge

FEATURES

Quality Construction: Close-grained cast iron body, specially treated for corrosion resistance. Drain port provided for easy winterizing.

Built-in Jet: High-strength Lexan nozzle and venturi for maximum resistance to corrosion and abrasion. Cleanout plug provided for ease of service.

Noryl Impeller: Precision-molded for perfect balance...ultra-smooth for highest performance and efficiency.

Precision-Molded Diffuser: Pump primes faster, handles more air, with multi-port, precision-molded, reinforced polypropylene diffuser.

Mechanical Shaft Seal: Precision lapped and highly polished carbon-ceramic, stainless steel construction. Internal design guarantees continuous water lubrication.

Motor Windings: Superior insulation materials protect against excessive moisture and contaminants...assure prolonged motor life.

Balanced Rotor: Diecast under high pressures for uniform performance and greater efficiency, dynamically balanced.

Heavy-Duty Ball Bearings: Shielded, permanently lubricated bearings, extensively tested to ensure extended life and smooth, quiet operation.

Pump and Motor Shaft: Stainless steel for maximum corrosion resistance; one-piece threaded shaft for positive impeller drive and alignment.

Pressure Switch: Professional quality, allows cut-in and differential adjustments.

ORDERING INFORMATION

CATALOG NUMBER	HP	SWITCH SETTING	DESCRIPTION	PIPE TAPPING SIZES		MOTOR VOLTAGE	APPROX. WT. LBS.
				SUCTION	DISCHARGE		
HNC	1/2	30-50	Shallow Well Jet	1-1/4"	1"	115/230	47
HND	3/4	30-50	Shallow Well Jet	1-1/4"	1"	115/230	65
HNE	1	30-50	Shallow Well Jet	1-1/4"	1"	115/230	70

Lexan® and Noryl® are registered trademarks of General Electric Co. All other brand or product names are trademarks or registered trademarks of Pentair Ltd.

ProJet™ HN Series Self-priming shallow well jet pumps

Cast Iron

OUTLINE DIMENSIONS

CATALOG NUMBER	L	B
HNC	18.7	7.1
HND	21.3	7.0
HNE	22.4	8.0

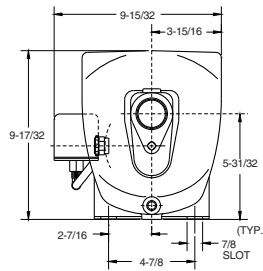

HNC

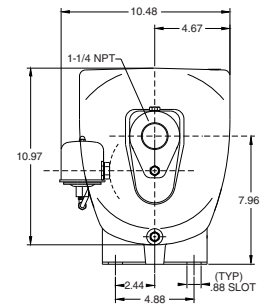

HND and HNE

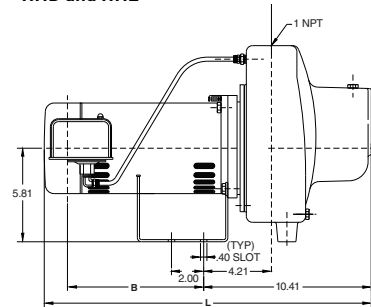
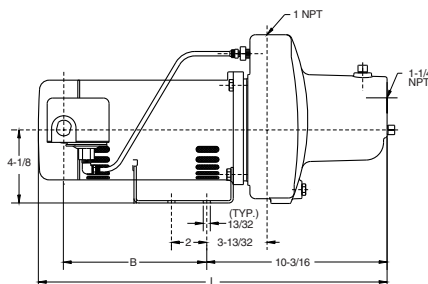

Dimensions (in inches) are for estimating purposes only.

PUMP PERFORMANCE

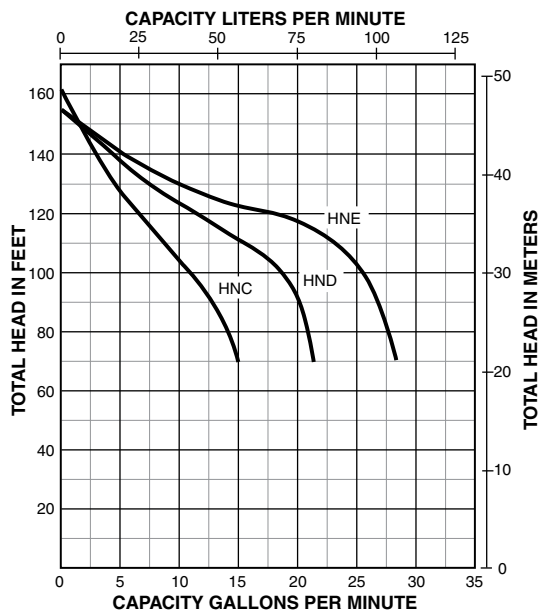

2.31 FT. OF HEAD = 1 PSI
1 FT. OF HEAD = .433 PSI

PUMP PERFORMANCE (CAPACITY IN GALLONS PER MINUTE)

CATALOG NUMBER	HP	DISCH. PRESSURE PSI	DYNAMIC SUCTION LIFT					SHUT-OFF PRESSURE PSI
			5'	10'	15'	20'	25'	
HNC	1/2	30	15.0	13.0	11.6	8.7	6.9	70
		40	12.5	11.4	10.1	8.2	6.8	
		50	8.0	6.8	6.1	4.8	3.5	
HND	3/4	30	21.4	19.1	16.5	13.3	9.5	67
		40	20.8	18.7	15.8	13.2	9.3	
		50	13.5	11.6	10.1	7.4	2.4	
HNE	1	30	28.5	25.0	21.4	17.4	12.6	67
		40	28.3	24.4	21.0	17.2	12.3	
		50	21.5	18.3	10.9	3.1	1.6	

Pump will operate at all depths shown, with pressure switch set at 30-50 PSI.

Tested and rated in accordance with Water Systems Council Standards.

NOTE: Pumps installed with a Pro-Source® tank require a 100 PSI relief valve. Pumps installed with a conventional tank require a 75 PSI relief valve. Relief valve must be capable of relieving entire flow of pump at relief pressure.

ProJet™ SN Series Self-priming shallow well jet pumps

Cast Iron

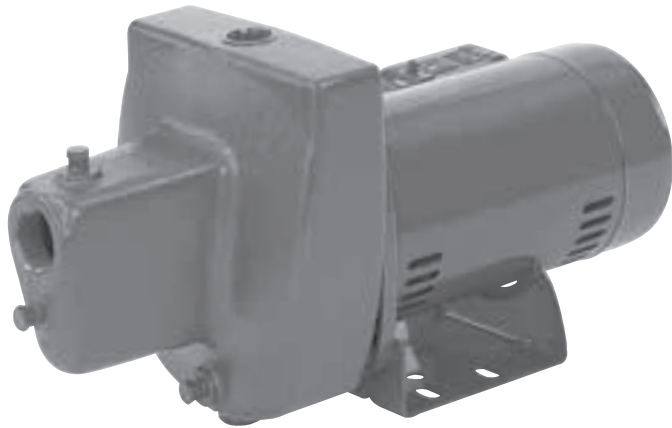

The ProJet SN Series Pumps provide excellent performance with good pressure for wells to 25' deep. Self-priming after the priming chamber has been filled with water.

APPLICATIONS

Water systems and sprinkling... for homes, farms and cottages.

SPECIFICATIONS

Max. Liquid Temperature: 140°F

Max. Inlet Pressure: 50 PSI

Average Priming Time (in minutes) at 15 Feet:

SNC = 2.3; SND = 1.7

SNE = 1.3; SNF = 1.1

Average Priming Time (in minutes) at 25 Feet:

SNC = 6.4; SND = 4.4

SNE = 4.4; SNF = 2.6

Body: Close-grained cast iron

Nozzle: High-strength Lexan®

Venturi: Lexan

Impeller: Noryl®

Diffuser: Reinforced polypropylene

Shaft: One-piece threaded, 416 grade stainless steel

Base: Steel, 12 gauge

ORDERING INFORMATION

CATALOG NUMBER	HP	SWITCH SETTING	DESCRIPTION	PIPE TAPPING SIZES		MOTOR VOLTAGE	APPROX. WT. LBS.
				SUCTION	DISCHARGE		
SNC	1/2	30-50	Shallow Well Jet	1-1/4"	1"	115/230	45
SNC-HF25L	1/2	20-40	Hi Flow, Shallow Well Jet	1-1/4"	1"	115/230	45
SND	3/4	30-50	Shallow Well Jet	1-1/4"	1"	115/230	47
SNE	1	30-50	Shallow Well Jet	1-1/4"	1"	115/230	55
SNF	1-1/2	30-50	Shallow Well Jet	1-1/4"	1"	115/230	60

Lexan® and Noryl® are registered trademarks of General Electric Co. All other brand or product names are trademarks or registered trademarks of Pentair Ltd.

FEATURES

Quality Construction: Close-grained cast iron body. Drain port provided for easy winterizing.

Built-in Jet: High-strength Lexan nozzle and venturi for maximum resistance to corrosion and abrasion. Cleanout plug provided for ease of service.

Noryl Impeller: Precision-molded for perfect balance...ultra-smooth for highest performance and efficiency.

Precision-Molded Diffuser: Pump primes faster, handles more air, with multi-port, precision-molded, reinforced polypropylene diffuser.

Mechanical Shaft Seal: Precision lapped and highly polished carbon-ceramic, stainless steel construction. Internal design guarantees continuous water lubrication.

Motor Windings: Superior insulation materials protect against excessive moisture and contaminants...assure prolonged motor life.

Balanced Rotor: Diecast under high pressures for uniform performance and greater efficiency, dynamically balanced.

Heavy-Duty Ball Bearings: Shielded, permanently lubricated bearings, extensively tested to ensure extended life and smooth, quiet operation.

Pump and Motor Shaft: Stainless steel for maximum corrosion resistance; one-piece threaded shaft for positive impeller drive and alignment.

Dustproof Cover: All electrical components are protected from dirt, dust and insects by a dustproof canopy; ventilating air cannot contaminate vital switching components.

Pressure Switch: Professional quality, allows cut-in adjustments.

ProJet™ SN Series Self-priming shallow well jet pumps

Cast Iron

OUTLINE DIMENSIONS

CATALOG NUMBER	L	B
SNC	18.7	7.1
SND	18.7	7.1
SNE	21.3	7.0
SNF	22.4	8.0

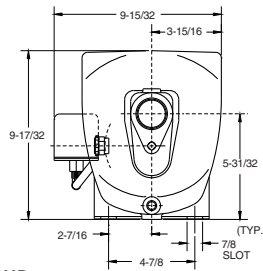

SNC and SND

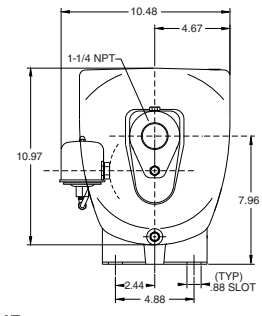

SNE and SNF

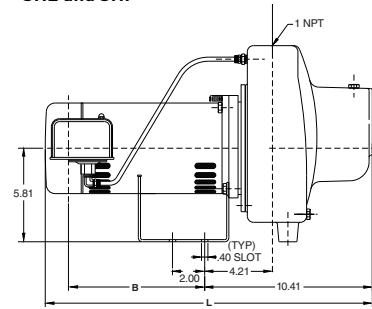
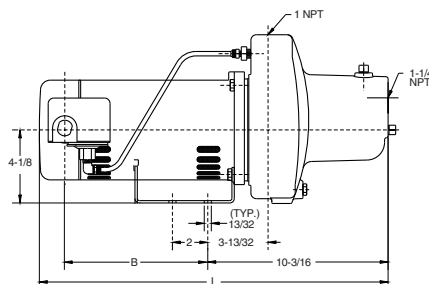

Dimensions (in inches) are for estimating purposes only.

PUMP PERFORMANCE

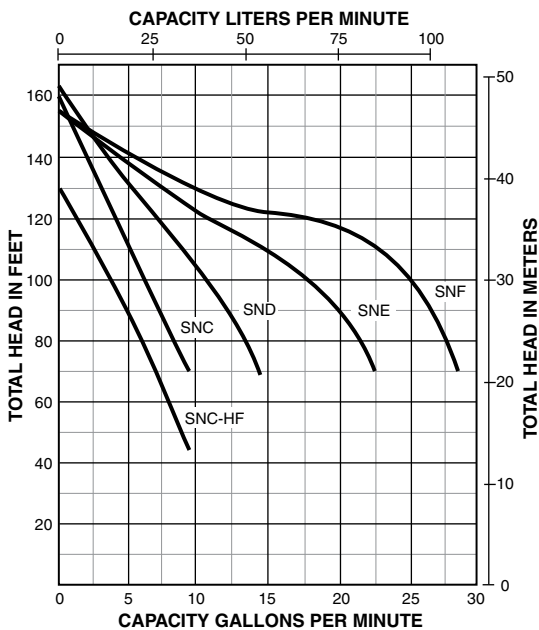

2.31 FT. OF HEAD = 1 PSI
1 FT. OF HEAD = .433 PSI

PUMP PERFORMANCE (CAPACITY IN GALLONS PER MINUTE)

CATALOG NUMBER	HP	DISCH. PRESSURE PSI	DYNAMIC SUCTION LIFT					SHUT-OFF PRESSURE PSI
			5'	10'	15'	20'	25'	
SNC-HF25L	1/2	20	13.7	12.3	10.6	8.8	6.3	56
		30	11.8	10.6	9.3	8.2	6.2	
		40	7.2	6.3	5.2	4.0	2.4	
SNC	1/2	30	9.7	8.3	7.4	5.9	4.3	70
		40	7.9	7.2	6.4	5.6	4.1	
		50	4.5	3.8	3.1	2.7	1.8	
SND	3/4	30	15.0	13.0	11.6	8.7	6.9	70
		40	12.5	11.4	10.1	8.2	6.8	
		50	8.0	6.8	6.1	4.8	3.5	
SNE	1	30	21.4	19.1	16.5	13.3	9.5	67
		40	20.8	18.7	15.8	13.2	9.3	
		50	13.5	11.6	10.1	7.4	2.4	
SNF	1-1/2	30	28.5	25.0	21.4	17.4	12.6	67
		40	28.3	24.4	21.0	17.2	12.3	
		50	21.5	18.3	10.9	3.1	1.6	

Pump will operate at all depths shown, with pressure switch set at 30-50 PSI. Tested and rated in accordance with Water Systems Council Standards.

NOTE: Pumps installed with a Pro-Source® tank require a 100 PSI relief valve. Pumps installed with a conventional tank require a 75 PSI relief valve. Relief valve must be capable of relieving entire flow of pump at relief pressure.

FN Series Self-priming shallow well jet pumps

Cast Iron

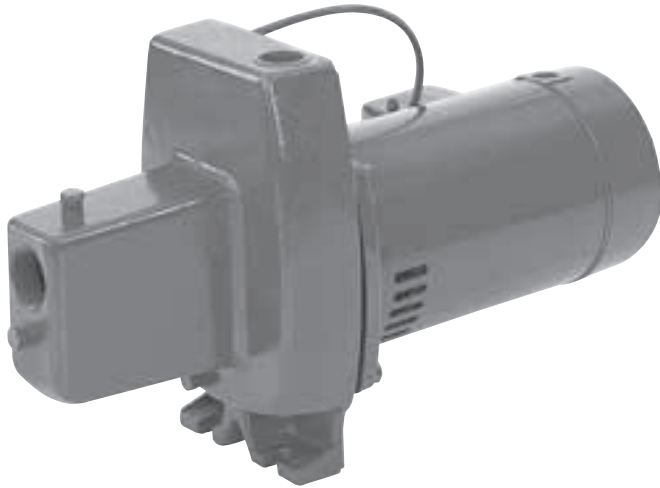

The FN Series provides strong performance with good pressure for wells to 25' deep. Self-priming after the priming chamber has been filled with water.

APPLICATIONS

Water systems and sprinkling... for homes, farms and cottages.

SPECIFICATIONS

FNC Priming Time (in minutes):

at 15': 2.25 minutes max.

at 25': 6.5 minutes max.

FND Priming Time (in minutes):

at 15': 1.7 minutes max.

at 25': 4.4 minutes max.

Max. Liquid Temperature: 140°F

FNC Max. Inlet Pressure: 60 PSI

FND Max. Inlet Pressure: 50 PSI

Max. Inlet PSI + Pump Discharge PSI:

Not to exceed 100 PSI

Body and Base: Close-grained cast iron

Nozzle: High-strength polycarbonate

Venturi: Polycarbonate

Impeller: Noryl®

Diffuser: Reinforced polypropylene

Shaft: One-piece threaded stainless steel

FEATURES

Quality Construction: Close-grained cast iron body and base, specially treated for corrosion resistance. Drain port provided for easy winterizing.

Built-in Jet: High-strength polycarbonate nozzle and venturi for maximum resistance to corrosion and abrasion. Cleanout plug provided for ease of service.

Noryl Impeller: Precision-molded for perfect balance...ultra-smooth for highest performance and efficiency.

Precision-Molded Diffuser: Pump primes faster, handles more air, with multi-port, precision-molded, reinforced polypropylene diffuser.

Mechanical Shaft Seal: Precision lapped and highly polished carbon-ceramic, stainless steel construction. Internal design guarantees continuous water lubrication.

Motor Windings: Superior insulation materials protect against excessive moisture and contaminants...assure prolonged motor life.

Balanced Rotor: Diecast under high pressures for uniform performance and greater efficiency, dynamically balanced.

Heavy-Duty Ball Bearings: Sealed, permanently lubricated bearings, extensively tested to ensure extended life and smooth, quiet operation.

Pump and Motor Shaft: Stainless steel for maximum corrosion resistance; one-piece threaded shaft for positive impeller drive and alignment.

Dustproof Cover: All electrical components are protected from dirt, dust and insects by a dustproof canopy; ventilating air cannot contaminate vital switching components.

Pressure Switch: Adjustable cut-in and fixed differential (20 PSI).

ORDERING INFORMATION

CATALOG NUMBER	HP	SWITCH SETTING	DESCRIPTION	PIPE TAPPING SIZES		MOTOR VOLTAGE	APPROX. WT. LBS.
				SUCTION	DISCHARGE		
FNC	1/2	30-50	Shallow Well Jet	1-1/4"	1"	115/230	46
FND	3/4	30-50	Shallow Well Jet	1-1/4"	1"	115/230	47

Noryl® is a registered trademark of General Electric Co.
All other brand or product names are trademarks or registered trademarks of Pentair Ltd.

FN Series Self-priming shallow well jet pumps

Cast Iron

OUTLINE DIMENSIONS

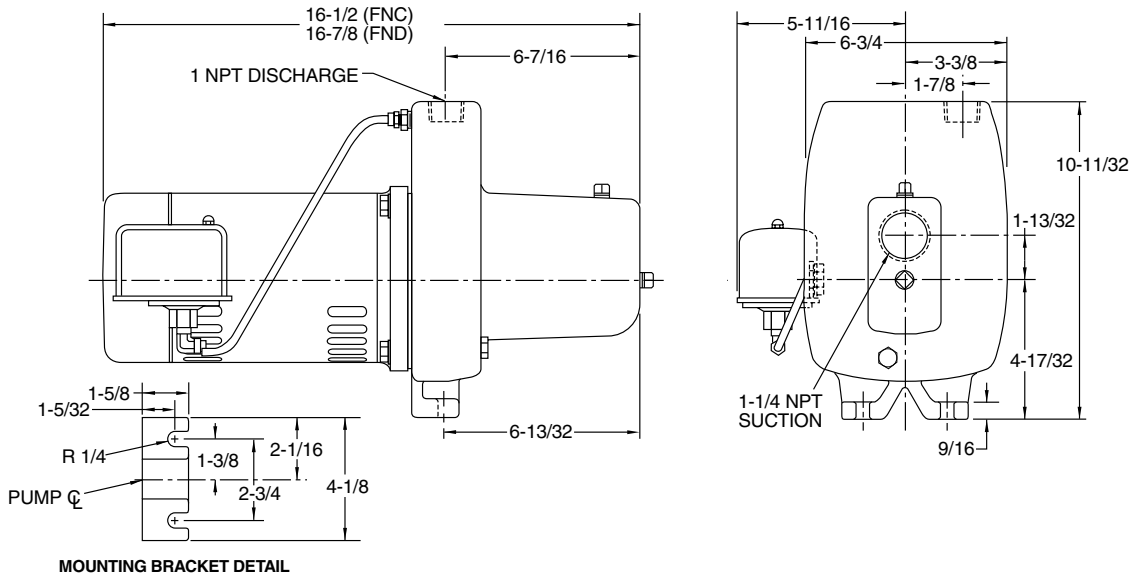

Dimensions (in inches) are for estimating purposes only.

PUMP PERFORMANCE

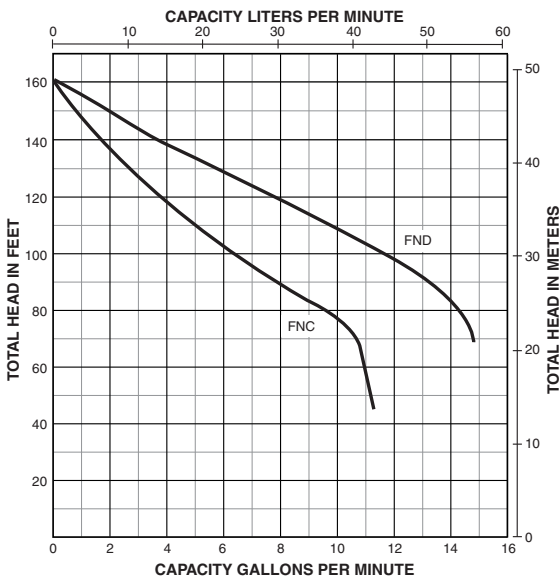

PUMP PERFORMANCE (CAPACITY IN GALLONS PER MINUTE)

CATALOG NUMBER	HP	DISCH. PRESSURE		DYNAMIC SUCTION LIFT					SHUT-OFF PRESSURE PSI
		PSI	FEET HEAD	5'	10'	15'	20'	25'	
FNC	1/2	20	46.2	9.8	8.8	7.5	6.2	4.5	69
		30	69.3	9.2	8.2	7.2	5.9	4.2	
		40	92.4	6.9	6.0	5.3	4.5	4.0	
		50	115.5	3.8	3.5	2.7	1.9	1.4	
FND	3/4	30	69.3	15.0	13.0	11.6	8.7	6.9	70
		40	92.4	12.5	11.4	10.1	8.2	6.8	
		50	115.5	8.0	6.8	6.1	4.8	3.5	

Pump will operate at all depths shown, with pressure switch set at 30-50 PSI.

Tested and rated in accordance with Water Systems Council Standards.

NOTE: Pumps installed with a Pro-Source® tank require a 100 PSI relief valve. Pumps installed with a conventional tank require a 75 PSI relief valve. Relief valve must be capable of relieving entire flow of pump at relief pressure.

PN Series Self-priming shallow well jet pumps

Corrosion-Resistant



PN Series Shallow Well Jet Pumps are corrosion- and abrasion-resistant and are ideal for wells with pumping levels of 25' or less.

Self-priming after the pump housing is initially filled with water.

Capacities to 18 GPM. Available in 1/2, 3/4 and 1 HP models.

Supplied with the industry standard 30-50 pressure switch setting.

APPLICATIONS

- Water Systems
- Booster Pump
- Marine Use
- Mist Sprayers – Poultry
- Fountains and Water Features

SPECIFICATIONS

- Body and Seal Plate:** Fiberglass-reinforced thermoplastic
- Impeller:** Engineered polymer
- Base:** 12-gauge steel
- Nozzle, Venturi, Diffuser:** Polypropylene

FEATURES

Quality Construction: Fiberglass-reinforced thermoplastic body provides total corrosion resistance and high resistance to abrasion.

Built-in Jet: Shallow-well jet has corrosion-resistant polypropylene nozzle and venturi.

Impeller: Precision-molded for perfect balance...ultra-smooth for highest performance and efficiency.

Precision-Molded Diffuser: Polypropylene diffuser allows pump to prime faster, handle more air.

Heavy-Duty Motor: Stainless steel shaft and dual heavy-duty ball bearings.

Heavy-Duty Ball Bearings: Shielded, permanently lubricated bearings, extensively tested to ensure extended life and smooth, quiet operation.

Dual Voltage Capability: Dual voltage motors are shipped at the 230-volt setting.

Professional Quality, Pre-set 30-50 PSI: Allows for cut-in pressure adjustments.

New Nozzle Cleanout: Easy plug removal and access for ease of service.

New Drain Plug: Bottom-mounted for easy draining and winterization.

ORDERING INFORMATION

CATALOG NUMBER	HP	DESCRIPTION	PIPE TAPPING SIZES		MOTOR VOLTAGE	APPROX. WT. LBS./KG
			SUCTION	DISCHARGE		
PNC	1/2	Shallow Well Jet	1-1/4"	1"	115/230	21/9.5
PND	3/4	Shallow Well Jet	1-1/4"	1"	115/230	24/11
PNE	1	Shallow Well Jet	1-1/4"	1"	115/230	26/12

PN Series Self-priming shallow well jet pumps

Corrosion-Resistant

OUTLINE DIMENSIONS

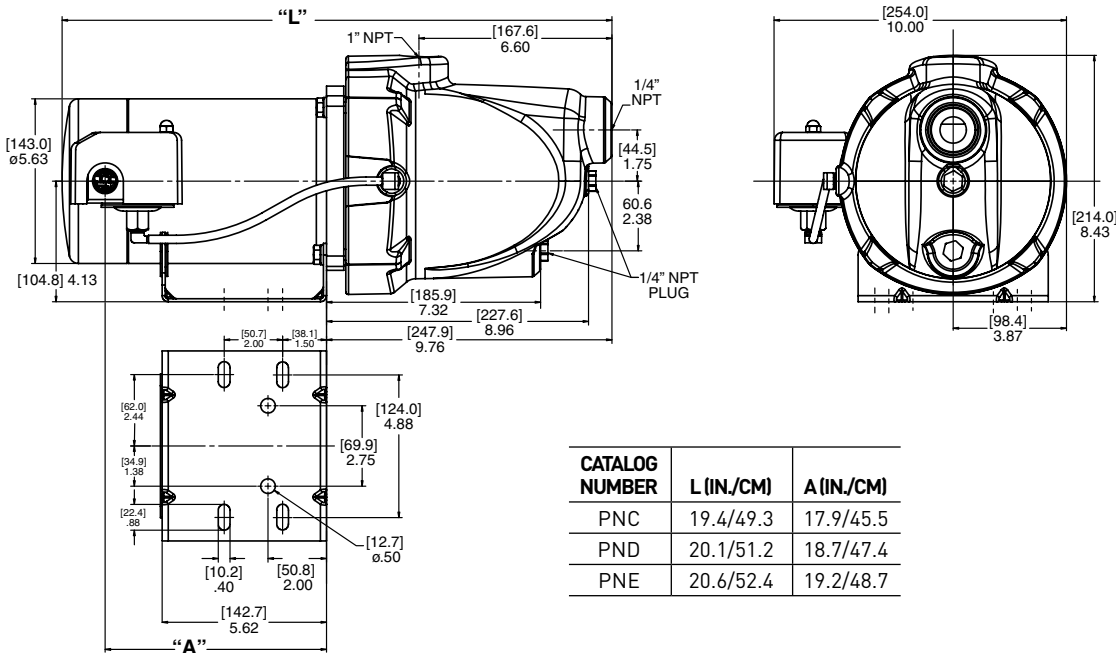

Dimensions (in inches) are for estimating purposes only.

PUMP PERFORMANCE: 10 GPM

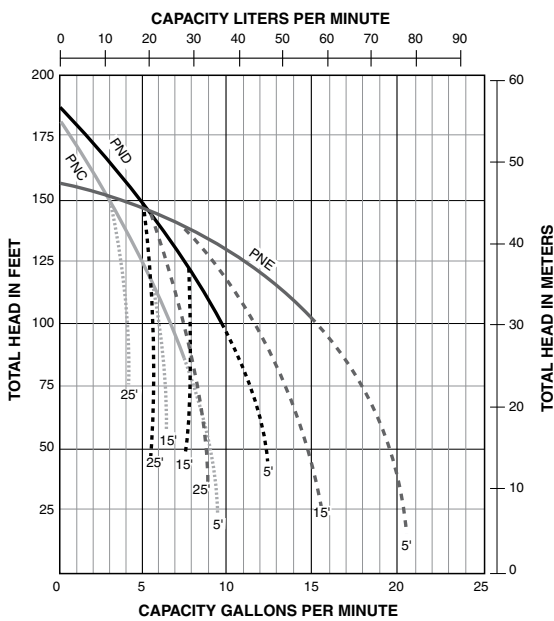

PUMP PERFORMANCE (Capacity in gallons/liters per minute)

CATALOG NUMBER	HP	TOTAL SUCTION LIFT FT./M	DISCHARGE PRESSURE PSI/BAR			SHUT-OFF PSI/BAR
			30/2.1	40/2.8	50/3.5	
PNC	1/2	5/1.5	8.5/32.2	7.4/28.0	5.2/19.7	77/5.30
		10/3.0	7.1/26.9	6.4/24.2	5.1/19.3	
		15/4.6	6.5/24.6	6.1/23.1	4.5/17.0	
		20/6.1	5.4/20.4	5.1/19.3	4.1/15.5	
PND	3/4	5/1.5	12.1/45.8	10.7/40.5	8.5/32.2	78/5.37
		10/3.0	10.7/40.5	10.2/38.6	8.4/31.8	
		15/4.6	9.0/34.1	8.5/32.2	8.1/30.7	
		20/6.1	7.6/28.8	7.3/27.6	7.1/26.9	
PNE	1	5/1.5	18.0/68.1	16.8/63.6	13.5/51.1	67/4.62
		10/3.0	17.1/64.7	16.1/60.9	13.4/50.7	
		15/4.6	14.9/56.4	14.4/54.5	13.0/49.2	
		20/6.1	12.6/47.7	12.2/46.2	12.0/45.4	
		25/7.6	8.8/33.3	8.5/32.2	8.1/30.7	

Pumps will operate at all depths shown, with pressure switch set at 30-50 PSI. Tested and rated in accordance with Water Systems Council Standards.

NOTE: Pumps installed with a Pro-Source® tank require a 100 PSI relief valve. Pumps installed with a conventional tank require a 75 PSI relief valve. Relief valve must be capable of relieving entire flow of pump at relief pressure.

ProJet™ HL Series Self-priming convertible jet pumps

Cast Iron

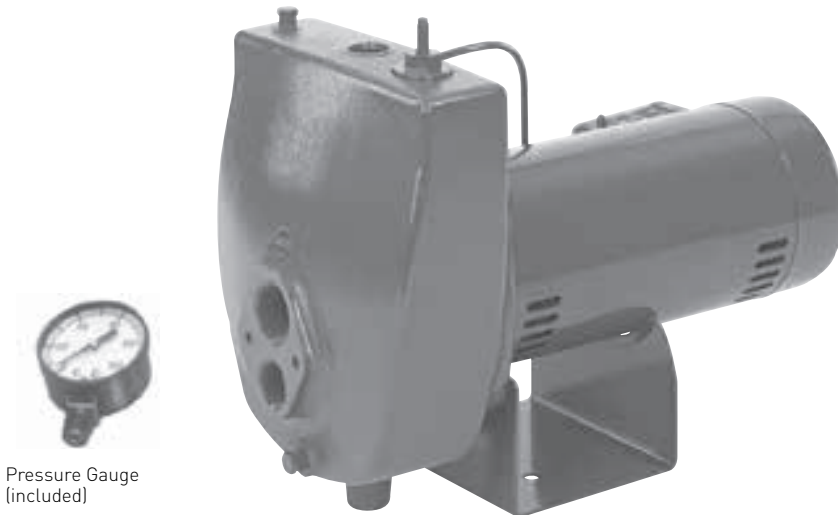

Pressure Gauge (included)



The ProJet HL convertible jet pumps offer a proven cast iron self-priming design available in 1/2 – 1 HP models. The ProJet HL convertible jets utilize built-in regulators offering easier priming and better range of performance from a complete line of shallow well, 4" double pipe, 2" and 3" single pipe jet packages.

APPLICATIONS

Water systems and sprinkling... for homes, farms and cottages.

SPECIFICATIONS

Body and Seal Plate: Close-grained cast iron

Impeller: High-strength Noryl®

Diffuser: Reinforced polypropylene with brass wear ring

Shaft: One-piece threaded 416 stainless steel

Base: Steel, 12 gauge

Max. Liquid Temperature: 140°F

Max. Inlet Pressure: 50 PSI

Pressure Switch Pre-Set: 30-50 PSI

Suction Ports: "Suction-over-Drive"

Pressure Gauge: 0-100 PSI

FEATURES

Quality Construction: Close-grained cast iron pump body is a rugged one-piece unit, specially treated to resist corrosion. Drain port provided for easy winterizing.

Noryl Impeller: Precision-molded for perfect balance...ultra-smooth for highest performance and efficiency.

Precision-Molded Diffuser: Pump primes faster, handles more air, with multi-port, precision-molded, reinforced polypropylene diffuser.

Pressure Switch: High quality, cut-in and differential pressure setting are adjustable.

Mechanical Shaft Seal: Precision lapped and highly polished carbon-ceramic, stainless steel construction. Internal design guarantees continuous water lubrication for maximum protection.

Motor Windings: Superior insulation materials protect against excessive moisture and contaminants...assures prolonged motor life.

Balanced Rotor: Diecast under high pressures for uniform performance and greater efficiency...dynamically balanced.

Heavy-Duty Ball Bearings: Shielded, permanently lubricated bearings, extensively tested to ensure extended life and smooth, quiet operation.

Pump and Motor Shaft: 416 stainless steel for maximum corrosion resistance; one-piece threaded shaft for positive impeller drive and alignment.

ORDERING INFORMATION

CATALOG NUMBER	HP	DESCRIPTION	PIPE TAPPING SIZES			MOTOR VOLTAGE	APPROX. WT. LBS.
			SUCTION	DRIVE	DISCHARGE		
HLC	1/2	Deep Well Jet	1-1/4"	1"	1"	115/230	42
HLD	3/4	Deep Well Jet	1-1/4"	1"	1"	115/230	60
HLE	1	Deep Well Jet	1-1/4"	1"	1"	115/230	65

A Jet Package should be ordered with every Series HL Pump.

NOTE: Pumps installed with a Pro-Source® tank require a 100 PSI relief valve. Pumps installed with a conventional tank require a 75 PSI relief valve. Relief valve must be capable of relieving flow of pump at relief pressure.

Noryl® is registered trademark of General Electric Co.

All other brand or product names are trademarks or registered trademarks of Pentair Ltd.

ProJet™ HL Series Self-priming convertible jet pumps

Cast Iron

OUTLINE DIMENSIONS

CATALOG NUMBER	HP	A	B
HLC	1/2	14.25	7.09

HLC

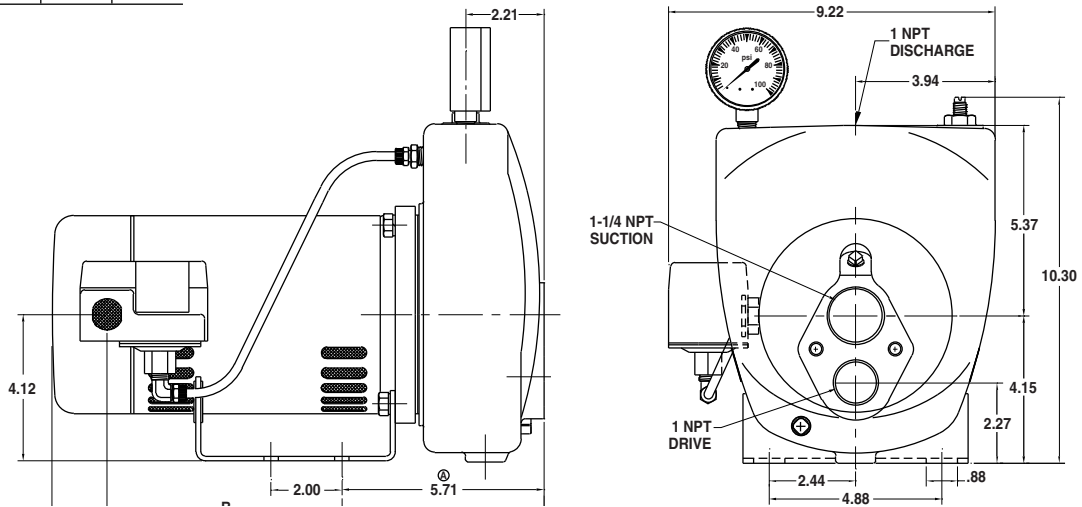

CATALOG NUMBER	HP	A	B
HLD	3/4	15.79	8.03
HLE	1	17.91	9.09

HLD and HLE

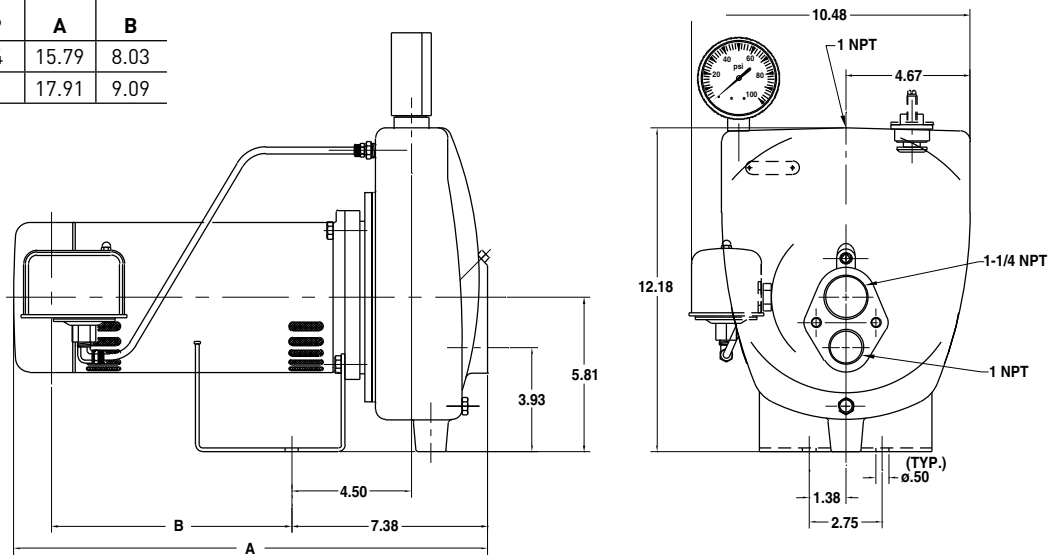

Dimensions (in inches) are for estimating purposes only.

NOTE: 1/4 NPT, 0-100 PSI pressure gauge supplied uninstalled to prevent shipping damage.

ProJet™ HL Series Self-priming convertible jet pumps

Cast Iron

PUMP PERFORMANCE (CAPACITY IN GALLONS PER MINUTE)
SHALLOW WELL – 5', 10', 15', 20' AND 25' PUMPING DEPTHS

CAT. NO.	HP	DISCH. PRESS.	PUMPING DEPTH TO WATER IN FEET																								
			5 FT. LIFT					10 FT. LIFT					15 FT. LIFT					20 FT. LIFT					25 FT. LIFT				
HLC	1/2	JET PACKAGE	11SD	10SD	29SD	CK5		11SD	10SD	29SD	CK5		11SD	10SD	29SD	CK5		11SD	10SD	29SD	CK5		11SD	10SD	29SD	CK5	
		Venturi N32P-	-68B	-67B	-66B	-66B		-68B	-67B	-66B	-66B		-68B	-67B	-66B	-66B		-68B	-67B	-66B	-66B		-68B	-67B	-66B	-66B	
		Nozzle J43P-	-44	-44	-41	-45		-44	-44	-41	-45		-44	-44	-41	-45		-44	-44	-41	-45		-44	-44	-41	-45	
		20 PSI	20.6	14.4	10.1	6.6		19.0	13.2	9.3	6.1		16.5	11.5	8.1	5.3		13.3	9.5	6.9	4.5		9.8	6.9	5.3	3.4	
		30 PSI	19.6	14.3	9.9	6.5		18.1	13.1	9.1	6.0		15.7	11.4	7.9	5.2		13.3	9.5	6.7	4.4		9.8	6.9	5.1	3.4	
		40 PSI	10.3	12.1	9.8	6.4		9.4	11.2	9.0	5.9		8.2	9.7	7.8	5.1		6.4	8.3	6.6	4.3		3.1	6.3	5.1	3.3	
		50 PSI		4.6	7.3	6.3			4.3	6.7	5.8			3.7	5.8	5.0			2.6	4.9	4.3			1.0	3.8	3.3	
		60 PSI			3.5	5.8				3.2	5.3				2.8	4.6				2.4	3.9					3.0	
Shut-off-PSI	55	59	70	72		53	57	66	67		50	55	64	65		48	53	61	63		46	51	59	61			
HLD	3/4	JET PACKAGE	12SD	11SD	CK1	CK5	CK1	12SD	11SD	CK1	CK5	CK1	12SD	11SD	CK1	CK5	CK1	12SD	11SD	CK1	CK5	CK1	12SD	11SD	CK1	CK5	CK1
		Venturi N32P-	-65	-68B	-72E	-67B	-72	-65	-68B	-72E	-67B	-72	-65	-68B	-72E	-67B	-72	-65	-68B	-72E	-67B	-72	-65	-68B	-72E	-67B	-72
		Nozzle J34P-	-44	-44	-43	-45	-43	-44	-44	-43	-45	-43	-44	-44	-43	-45	-43	-44	-44	-43	-45	-43	-44	-44	-43	-45	-43
		20 PSI	24.2	20.3	14.5	12.6	8.6	23.2	19.4	13.9	12.1	8.3	20.2	16.9	12.1	10.5	7.2	17.7	13.6	10.3	8.2	6.1	12.5	10.4	7.9	6.2	4.7
		30 PSI	24.0	20.3	14.4	12.4	8.5	23.0	19.4	13.8	11.8	8.2	20.0	16.9	12.0	10.3	7.1	17.7	13.6	10.2	8.0	6.0	12.5	10.4	7.8	6.0	4.6
		40 PSI	16.7	16.4	13.7	12.2	8.3	16.0	15.8	13.1	11.7	7.9	13.9	13.7	11.4	10.2	6.9	16.0	11.5	9.7	7.8	5.9	10.3	8.3	7.4	5.8	4.5
		50 PSI			12.6	12.0	8.2			12.1	11.5	7.8			10.5	10.0	6.8			8.9	7.7	5.8			6.8	5.7	4.4
		60 PSI			6.0	8.2	6.1			5.8	7.8	5.9			5.0	6.8	5.1			4.3	5.8	4.3			3.3	4.8	3.3
70 PSI				4.2	2.9				4.0	2.8				3.5	2.4				2.8	2.0				2.0	1.6		
Shut-off-PSI	61	62	71	80	82	59	60	69	78	79	57	58	67	76	77	54	55	65	74	75	52	53	63	72	73		
HLE	1	JET PACKAGE	12SD	CK2	60SD			12SD	CK2	60SD			12SD	CK2	60SD			12SD	CK2	60SD			12SD	CK2	60SD		
		Venturi N32P-	-65	-64	-64			-65	-64	-64			-65	-64	-64			-65	-64	-64			-65	-64	-64		
		Nozzle J34P-	-44	-44	-45			-44	-44	-45			-44	-44	-45			-44	-44	-45			-44	-44	-45		
		20 PSI	26.8	21.6	18.4			24.6	19.9	16.9			21.4	17.3	14.7			18.2	14.7	12.5			13.9	11.2	9.6		
		30 PSI	26.5	21.5	18.1			24.4	19.8	16.7			21.2	17.2	14.5			18.0	14.6	12.3			13.8	11.2	9.4		
		40 PSI	22.9	21.3	17.5			21.0	19.6	16.1			18.3	17.0	14.0			15.6	14.5	11.9			11.9	11.1	9.1		
		50 PSI	15.1	16.8	17.3			13.9	15.4	15.9			12.1	13.4	13.8			10.3	11.4	11.7			7.9	8.7	9.0		
		60 PSI		4.0	15.6				3.7	14.4				3.2	12.5				2.7	10.6				2.1	8.1		
70 PSI			4.1					3.8					3.3					2.8									
Shut-off-PSI	61	71	77			59	69	75			57	67	73			55	65	71			53	63	68				

NOTE: Pumps are supplied with 30-50 pressure switch setting. Cut-in/Cut-out pressure settings are adjustable.

ProJet™ HL Series Self-priming convertible jet pumps

Cast Iron

PUMP PERFORMANCE (CAPACITY IN GALLONS PER MINUTE)
DEEP WELL (40 PSI) 4" DOUBLE PIPE

CAT. NO.	HP	JET NO.	USES VENTURI	USES NOZZLE	PUMPING DEPTH IN FEET												MAX. PUMP SHUT-OFF PRESSURE PSI	
					20'	30'	40'	50'	60'	70'	80'	90'	100'	110'	120'	JET AT 20 FT. DEPTH	JET AT MAX. DEPTH	
HLC	1/2	CK3	J32P-26	J34P-41	9.4	8.0	6.6										77	68
		54SD	J32P-22	J34P-44	8.0	6.9	5.7	4.8	3.8	3.2							94	70
		CK5	N32P-66B	J34P-45	7.3	6.2	5.0	4.0									83	69
		55SD	J32P-18	J34P-43	5.0	4.3	3.7	3.2	2.6	2.2	1.8	1.5					96	63
HLD	3/4	CK1	N32P-72	J34P-43	13.2	10.8	8.4	6.3	4.2								74	56
		CK2	J32P-24	J34P-44	13.0	11.5	9.9	8.7	7.5	6.6	5.4						105	80
		54SD	J32P-22	J34P-44	8.2	7.7	6.7	6.3	5.8	5.4	4.8	4.0	3.7	3.4	2.7		122	73
HLE	1	54SD	J32P-22	J34P-44	9.5	8.5	7.4	6.9	6.5	6.0	5.4	4.8	4.2	3.6	2.9		127	76

NOTE: Tank body on HLE pump tapped 1-1/4" x 1". On HLE pump, drop pipe should be increased to 1-1/2" x 1-1/4" to ensure adequate capacity from pump.

PUMP PERFORMANCE (CAPACITY IN GALLONS PER MINUTE)
DEEP WELL (40 PSI) 2" SINGLE PIPE

CAT. NO.	HP	JET NO.	USES VENTURI	USES NOZZLE	PUMPING DEPTH IN FEET												MAX. PUMP SHUT-OFF PRESSURE PSI	
					20'	30'	40'	50'	60'	70'	80'	90'	100'	110'	120'	JET AT 20 FT. DEPTH	JET AT MAX. DEPTH	
HLC	1/2	54AP	J32P-22	J34P-44	7.4	6.3	5.2	3.9	2.5	2.0							82	54
HLD	3/4	10AP	J32P-24	J34P-44	10.5	10.0	8.1	6.2									96	79
		54AP	J32P-22	J34P-44	6.0	5.3	4.8	4.2	4.1	3.7	3.5	2.8	2.1	1.6			95	53
HLE	1	9AP	J32P-29	J34P-44	11.7	11.1	9.8	6.8									69	57
		8AP	J32P-18	J34P-42	6.7	5.8	5.3	4.7	4.5	4.1	3.8	3.1	2.6	2.0	1.6		129	72

DEEP WELL (40 PSI) 3" SINGLE PIPE

HLC	1/2	9CP	J32P-26	J34P-41	9.4	8.0	6.6										77	68
		54CP	J32P-22	J34P-44	8.0	6.9	5.7	4.8	3.8	3.2								94
HLD	3/4	18CP	J32P-24	J34P-44	13.0	11.5	9.9	8.7	7.5	6.6	5.4						106	80
		54CP	J32P-22	J34P-44	8.5	7.7	6.7	6.3	5.8	5.4	4.8	4.0	3.7	3.4	2.7		122	73
		57CP	J32P-33	P122-108	18.0	15.4	12.8	10.8									81	68
HLE	1	54CP	J32P-22	J34P-44	9.5	8.5	7.4	6.9	6.5	6.0	5.4	4.8	4.2	3.6	2.9		127	76

Tank body on HLE pump tapped 1-1/4" x 1". Drop pipe should be increased to 1-1/2" x 1-1/4" to ensure adequate capacity from pump. Tested and rated in accordance with Water Systems Council Standards.

NOTE: Pumps installed with a Pro-Source® tank require a 100 PSI relief valve. Pumps installed with a conventional tank require a 75 PSI relief valve. Relief valve must be capable of relieving entire flow of pump at relief pressure.

ProJet™ SL Series Self-priming convertible jet pumps

Cast Iron

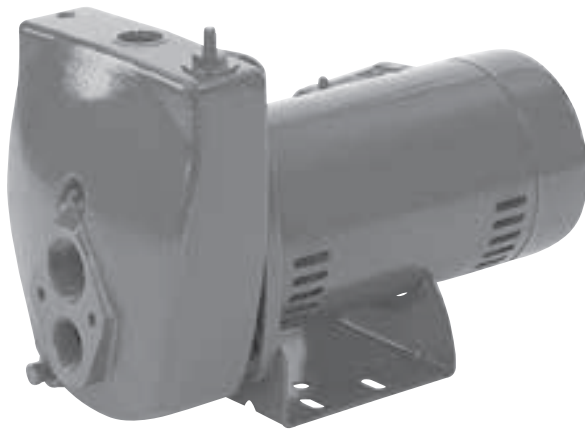

The ProJet SL convertible jet pumps offer a proven cast iron self-priming design available in 1/2 to 1-1/2 HP models. The ProJet SL convertible jets utilize the built-in regulators, offering easier priming and better range of performance from a complete line of shallow well, 4" double pipe, 2" and 3" single pipe jet packages.

APPLICATIONS

Water systems and sprinkling... for homes, farms and cottages.

SPECIFICATIONS

- Body and Seal Plate:** Close-grained cast iron
- Impeller:** High-strength Noryl®
- Diffuser:** Reinforced polypropylene with brass wear ring
- Shaft:** One-piece threaded 416 stainless steel
- Base:** Steel, 12 gauge
- Max. Liquid Temperature:** 140°F
- Max. Inlet Pressure:** 50 PSI
- Pressure Switch Pre-Set:** 30-50 PSI
- Suction Ports:** "Suction-over-Drive"

FEATURES

- Quality Construction:** Close-grained cast iron pump body is rugged one-piece unit, specially treated to resist corrosion. Drain port provided for easy winterizing.
- Noryl Impeller:** Precision-molded for perfect balance...ultra-smooth for highest performance and efficiency.
- Precision-Molded Diffuser:** Pump primes faster, handles more air, with multi-port, precision-molded, reinforced polypropylene diffuser.
- Pressure Switch:** High-quality, cut-in pressure setting is adjustable. Fixed 20 PSI differential.
- Mechanical Shaft Seal:** Precision-lapped and highly polished carbon-ceramic, stainless steel construction. Internal design guarantees continuous water lubrication for maximum protection.
- Motor Windings:** Superior insulation materials protect against excessive moisture and contaminants...assures prolonged motor life.
- Balanced Rotor:** Diecast under high pressures for uniform performance and greater efficiency...dynamically balanced.
- Heavy-Duty Ball Bearings:** Shielded, permanently lubricated bearings, extensively tested to ensure extended life and smooth, quiet operation.
- Pump and Motor Shaft:** 416 stainless steel for maximum corrosion resistance; one-piece threaded shaft for positive impeller drive and alignment.
- Dustproof Cover:** Dustproof canopy protects all electrical components from dirt, dust and insects; ventilating air cannot contaminate vital switching components... eliminates the most common cause of motor failure.

ORDERING INFORMATION

CATALOG NUMBER	HP	DESCRIPTION	PIPE TAPPING SIZES			MOTOR VOLTAGE	APPROX. WT. LBS.
			SUCT.	DRIVE	DISCH.		
SLC	1/2	Deep Well Jet	1-1/4"	1"	1"	115/230	40
SLD	3/4	Deep Well Jet	1-1/4"	1"	1"	115/230	42
SLE	1	Deep Well Jet	1-1/4"	1"	1"	115/230	60
SLF	1-1/2	Deep Well Jet	1-1/4"	1"	1"	115/230	65

A Jet Package should be ordered with every SL Series Pump.

NOTE: Pumps installed with a Pro-Source® tank require a 100 PSI relief valve. Pumps installed with a conventional tank require a 75 PSI relief valve. Relief valve must be capable of relieving flow of pump at relief pressure.

Noryl® is registered trademark of General Electric Co.

All other brand or product names are trademarks or registered trademarks of Pentair Ltd.

ProJet™ SL Series Self-priming convertible jet pumps

Cast Iron

OUTLINE DIMENSIONS

CATALOG NUMBER	HP	ADIM.	BDIM.
SLC	1/2	13.62	6.46
SLD	3/4	14.25	7.09

SLC and SLD

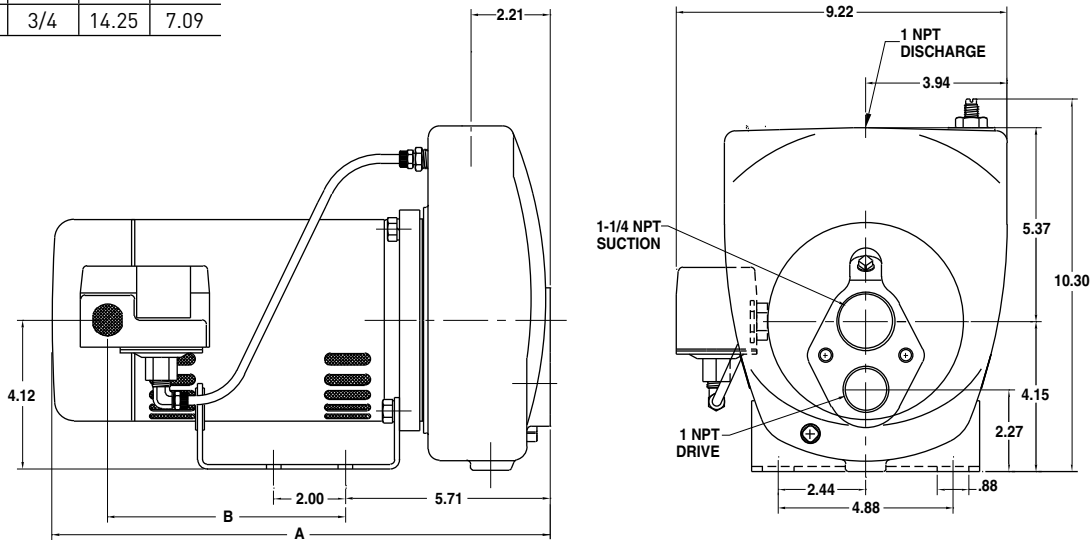

CATALOG NUMBER	HP	ADIM.	BDIM.
SLE	1	15.79	8.03
SLF	1-1/2	17.91	9.09

SLE and SLF

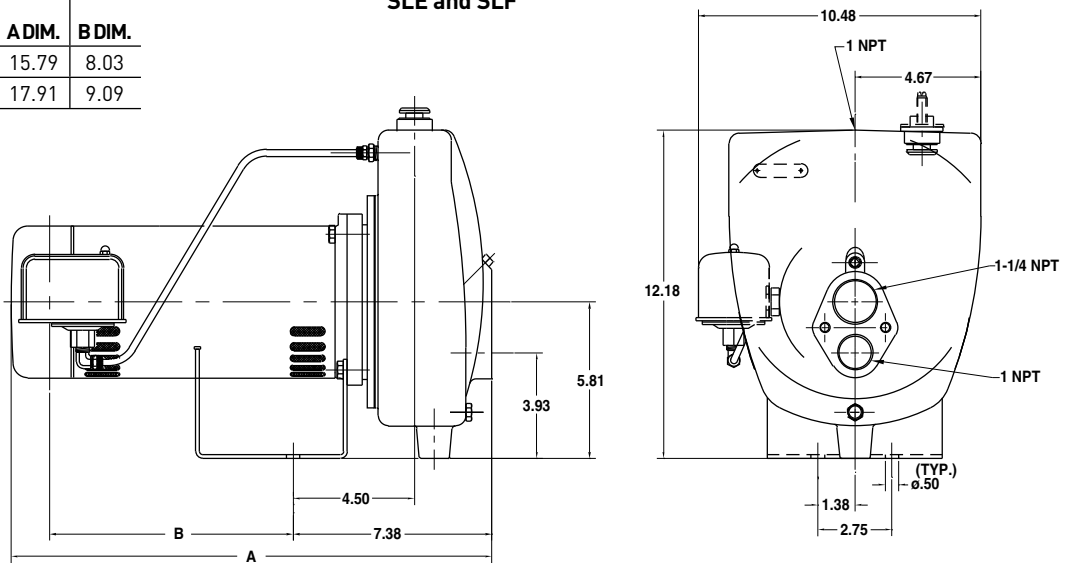

Dimensions (in inches) are for estimating purposes only.

ProJet™ SL Series Self-priming convertible jet pumps

Cast Iron

PUMP PERFORMANCE (CAPACITY IN GALLONS PER MINUTE)
SHALLOW WELL – 5', 10', 15', 20' AND 25' PUMPING DEPTHS

CAT. NO.	HP	DISCH. PRESS.	PUMPING DEPTH TO WATER IN FEET																								
			5 FT. LIFT					10 FT. LIFT					15 FT. LIFT					20 FT. LIFT					25 FT. LIFT				
SLC	1/2	JET PACKAGE	10SD	29SD	CK3			10SD	29SD	CK3			10SD	29SD	CK3			10SD	29SD	CK3			10SD	29SD	CK3		
		Venturi N32P-	-67B	-66B	-78B			-67B	-66B	-78B			-67B	-66B	-78B			-67B	-66B	-78B			-67B	-66B	-78B		
		Nozzle J34P-	-44	-41	-41			-44	-41	-41			-44	-41	-41			-44	-41	-41			-44	-41	-41		
		20 PSI	12.0	9.1	5.9			9.7	8.4	5.4			12.0	7.3	4.7			9.7	6.2	4.0			6.7	4.7	3.1		
		30 PSI	10.8	9.0	5.8			9.5	8.3	5.3			10.8	7.2	4.6			9.5	6.1	3.9			6.7	4.7	3.0		
		40 PSI	5.2	7.9	5.6			4.2	7.2	5.2			5.2	6.3	4.5			4.2	5.4	3.8			2.5	4.1	2.9		
		50 PSI		4.1	4.5				3.8	4.1				3.3	3.6				2.8	3.1				2.1	2.3		
		60 PSI			2.4					2.2					1.9					1.6							
Shut-off-PSI	53	61	70			51	58	66			49	56	64			47	54	61			45	52	58				
SLD	3/4	JET PACKAGE	11SD	10SD	29SD	CK5			11SD	10SD	29SD	CK5			11SD	10SD	29SD	CK5			11SD	10SD	29SD	CK5			
		Venturi N32P-	-68B	-67B	-66B	-66B			-68B	-67B	-66B	-66B			-68B	-67B	-66B	-66B			-68B	-67B	-66B	-66B			
		Nozzle J34P-	-44	-44	-41	-45			-44	-44	-41	-45			-44	-44	-41	-45			-44	-44	-41	-45			
		20 PSI	20.6	14.4	10.1	6.6			19.0	13.2	9.3	6.1			16.5	11.5	8.1	5.3			13.3	9.5	6.9	4.5			
		30 PSI	19.6	14.3	9.9	6.5			18.1	13.1	9.1	6.0			15.7	11.4	7.9	5.2			13.3	9.5	6.7	4.4			
		40 PSI	10.3	12.1	9.8	6.4			9.4	11.2	9.0	5.9			8.2	9.7	7.8	5.1			6.4	8.3	6.6	4.3			
		50 PSI		4.6	7.3	6.3				4.3	6.7	5.8				3.7	5.8	5.0				2.6	4.9	4.3			
		60 PSI			3.5	5.8					3.2	5.3					2.8	4.6					2.4	3.9			
Shut-off-PSI	55	59	70	72			53	57	66	67			50	55	64	65			48	53	61	63					
SLE	1	JET PACKAGE	12SD	11SD	CK1	CK5	CK1	12SD	11SD	CK1	CK5	CK1	12SD	11SD	CK1	CK5	CK1	12SD	11SD	CK1	CK5	CK1	12SD	11SD	CK1	CK5	CK1
		Venturi N32P-	-65	-68B	-72E	-67B	-72	-65	-68B	-72E	-67B	-72	-65	-68B	-72E	-67B	-72	-65	-68B	-72E	-67B	-72	-65	-68B	-72E	-67B	-72
		Nozzle J34P-	-44	-44	-43	-45	-43	-44	-44	-43	-45	-43	-44	-44	-43	45	-43	-44	-44	-43	-45	-43	-44	-44	-43	-45	-43
		20 PSI	24.2	20.3	14.5	12.6	8.6	23.2	19.4	13.9	12.1	8.3	20.2	16.9	12.1	10.5	7.2	17.7	13.6	10.3	8.2	6.1	12.5	10.4	7.9	6.2	4.7
		30 PSI	24.0	20.3	14.4	12.4	8.5	23.0	19.4	13.8	11.8	8.2	20.0	16.9	12.0	10.3	7.1	17.7	13.6	10.2	8.0	6.0	12.5	10.4	7.8	6.0	4.6
		40 PSI	16.7	16.4	13.7	12.2	8.3	16.0	15.8	13.1	11.7	7.9	13.9	13.7	11.4	10.2	6.9	11.8	11.5	9.7	7.8	5.9	10.3	8.3	7.4	5.8	4.5
		50 PSI			12.6	12.0	8.2			12.1	11.5	7.8			10.5	10.0	6.8			8.9	7.7	5.8			6.8	5.7	4.4
		60 PSI			6.0	8.2	6.1			5.8	7.8	5.9			5.0	6.8	5.1			4.3	5.8	4.3			3.3	4.8	3.3
70 PSI				4.2	2.9				4.0	2.8				3.5	2.4				2.8	2.0				2.0	1.6		
Shut-off-PSI	61	62	71	80	82	59	60	69	78	79	57	58	67	76	77	54	55	65	74	75	52	53	63	72	73		
SLF	1-1/2	JET PACKAGE	12SD	CK2	60SD			12SD	CK2	60SD			12SD	CK2	60SD			12SD	CK2	60SD			12SD	CK2	60SD		
		Venturi N32P-	-65	-64	-64			-65	-64	-64			-65	-64	-64			-65	-64	-64			-65	-64	-64		
		Nozzle J34P-	-44	-44	-45			-44	-44	-45			-44	-44	-45			-44	-44	-45			-44	-44	-45		
		20 PSI	26.8	21.6	18.4			24.6	19.9	16.9			21.4	17.3	14.7			18.2	14.7	12.5			13.9	11.2	9.6		
		30 PSI	26.5	21.5	18.1			24.4	19.8	16.7			21.2	17.2	14.5			18.0	14.6	12.3			13.8	11.2	9.4		
		40 PSI	22.9	21.3	17.5			21.0	19.6	16.1			18.3	17.0	14.0			15.6	14.5	11.9			11.9	11.1	9.1		
		50 PSI	15.1	16.8	17.3			13.9	15.4	15.9			12.1	13.4	13.8			10.3	11.4	11.7			7.9	8.7	9.0		
		60 PSI		4.0	15.6				3.7	14.4				3.2	12.5				2.7	10.6				2.1	8.1		
70 PSI			4.1					3.8					3.3					2.8									
Shut-off-PSI	61	71	77			59	69	75			57	67	73			55	65	71			53	63	68				

Pumps are supplied with 30-50 pressure switch setting. Cut-in pressure settings are adjustable.

ProJet™ SL Series Self-priming convertible jet pumps

Cast Iron

PUMP PERFORMANCE (CAPACITY IN GALLONS PER MINUTE) DEEP WELL (40 PSI) 4" SINGLE PIPE

CAT. NO.	HP	JET NO.	USES VENTURI	USES NOZZLE	PUMPING DEPTH IN FEET											MAX. PUMP SHUT-OFF PRESSURE PSI		
					20'	30'	40'	50'	60'	70'	80'	90'	100'	110'	120'	JET AT 20 FT. DEPTH	JET AT MAX. DEPTH	
SLC	1/2	4SD	J32P-24	J34P-41	5.9	4.5	3.4	2.3									68	54
		15SD	J32P-18	J34P-42	4.6	3.9	3.3	2.8	2.3	1.7							84	59
SLD	3/4	CK3	J32P-26	J34P-41	9.4	8.0	6.6										77	68
		54SD	J32P-22	J34P-44	8.0	6.9	5.7	4.8	3.8	3.2							94	70
		CK5	N32P-66B	J34P-45	7.3	6.2	5.0	4.0									83	69
		55SD	J32P-18	J34P-43	5.0	4.3	3.7	3.2	2.6	2.2	1.8	1.5					96	63
SLE	1	CK1	N32P-72	J34P-43	13.2	10.8	8.4	6.3	4.2								74	56
		CK2	J32P-24	J34P-44	13.0	11.5	9.9	8.7	7.5	6.6	5.4						105	80
		54SD	J32P-22	J34P-44	8.5	7.7	6.7	6.3	5.8	5.4	4.8	4.0	3.7	3.4	2.7	122	73	
SLF	1-1/2	54SD	J32P-22	J34P-44	9.5	8.5	7.4	6.9	6.5	6.0	5.5	4.8	4.2	3.6	2.9	127	76	

Tank body on SLF pump tapped 1-1/4" x 1". On SLF pump, drop pipe should be increased to 1-1/2" x 1-1/4" to ensure adequate capacity from pump.

PUMP PERFORMANCE (CAPACITY IN GALLONS PER MINUTE) DEEP WELL (40 PSI) 2" SINGLE PIPE

CAT. NO.	HP	JET NO.	USES VENTURI	USES NOZZLE	PUMPING DEPTH IN FEET											MAX. PUMP SHUT-OFF PRESSURE PSI		
					20'	30'	40'	50'	60'	70'	80'	90'	100'	110'	120'	JET AT 20 FT. DEPTH	JET AT MAX. DEPTH	
SLC	1/2	8AP	J32P-18	J34P-42	4.7	4.1	3.4	2.5	1.9	1.5							84	58
SLD	3/4	54AP	J32P-22	J34P-44	7.4	6.3	5.2	3.9	2.5	2.0							82	54
SLE	1	10AP	J32P-24	J34P-44	10.5	10.0	8.1	6.2									96	79
		54AP	J32P-22	J34P-44	6.0	5.3	4.8	4.2	4.1	3.7	3.5	2.8	2.1	1.6			95	53
SLF	1-1/2	9AP	J32P-29	J34P-44	11.7	11.1	9.8	6.8									69	57
		8AP	J32P-18	J34P-42	6.7	5.8	5.3	4.7	4.5	4.1	3.8	3.1	2.6	2.0	1.6	129	72	

DEEP WELL (40 PSI) 3" SINGLE PIPE

SLC	1/2	19CP	J32P-24	J34P-41	5.9	4.5	3.4	2.3									68	54
		16CP	J32P-18	J34P-42	4.6	3.9	3.3	2.8	2.3	1.7							84	59
		9CP	J32P-26	J34P-41	9.4	8.0	6.6										77	68
SLD	3/4	54CP	J32P-22	J34P-44	8.0	6.9	5.7	4.8	3.8	3.2							94	70
SLE	1	18CP	J32P-24	J34P-44	13.0	11.5	9.9	8.7	7.5	6.6	5.4						106	80
		54CP	J32P-22	J34P-44	8.5	7.7	6.7	6.3	5.8	5.4	4.8	4.0	3.7	3.4	2.7	122	73	
		57CP	J32P-33	P122-10B	18.0	15.4	12.8	10.8									81	68
SLF	1-1/2	54CP	J32P-22	J34P-44	9.5	8.5	7.4	6.9	6.5	6.0	5.4	4.8	4.2	3.6	2.9	127	76	

Tank body on SLF pump tapped 1-1/4" x 1". Drop pipe should be increased to 1-1/2" x 1-1/4" to ensure adequate capacity from pump. Tested and rated in accordance with Water Systems Council Standards.

NOTE: Pumps installed with a Pro-Source® tank require a 100 PSI relief valve. Pumps installed with a conventional tank require a 75 PSI relief valve. Relief valve must be capable of relieving entire flow of pump at relief pressure.

FL Series Self-priming convertible jet pumps

Cast Iron

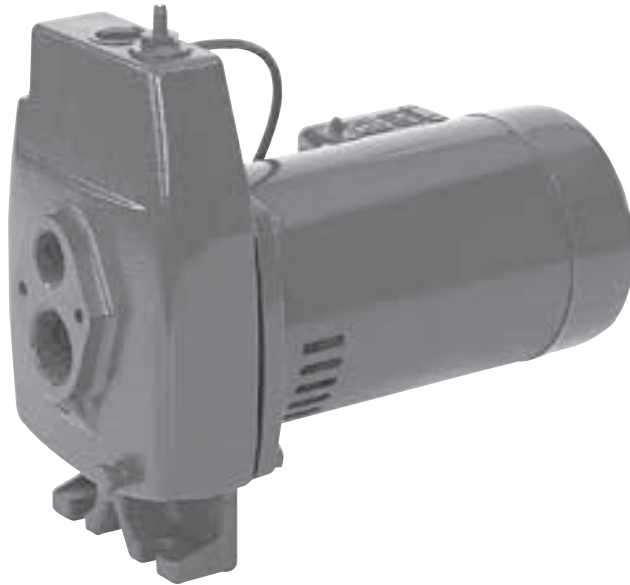

FEATURES

Quality Construction: Close-grained cast iron pump body and base are rugged one-piece unit, specially treated to resist corrosion. Drain port provided for easy winterizing.

Pressure Regulator: Simple, built-in regulator is performance proven. Adjustable for best performance on all deep well installations.

Lexan Impeller: Precision-molded for perfect balance...ultra-smooth for highest performance and efficiency.

Precision-Molded Diffuser: Pump primes faster, handles more air, with multi-port, precision-molded, reinforced polypropylene diffuser.

Mechanical Shaft Seal: Precision-lapped and highly polished carbon-ceramic, stainless steel construction. Internal design guarantees continuous water lubrication for maximum protection.

Motor Windings: Superior insulation materials protect against excessive moisture and contaminants...assures prolonged motor life.

Balanced Rotor: Diecast under high pressures for uniform performance and greater efficiency...dynamically balanced.

Heavy-Duty Ball Bearings: Shielded, permanently lubricated bearings, extensively tested to ensure extended life and smooth, quiet operation.

Pump and Motor Shaft: Stainless steel for maximum corrosion resistance; one-piece threaded shaft for positive impeller drive and alignment.

Dustproof Cover: Dustproof canopy protects all electrical components from dirt, dust and insects; ventilating air cannot contaminate vital switching components... eliminates the most common cause of motor failure.

FL Series Pumps feature a proven self-priming “convertible” design. The same convertible jet can be attached to pump for use on shallow well installation, or be utilized in 4” or larger wells for use as a double pipe deep well jet.

FL Series Pumps provide high capacities up to 11 GPM...depths to 90 feet. They are rated for 30-50 PSI operation.

APPLICATIONS

Water systems and sprinkling...for homes, farms and cottages

SPECIFICATIONS

Body and Base: Close-grained cast iron

Impeller: Lexan®

Diffuser: Reinforced polypropylene

Shaft: One-piece threaded 416 stainless steel

Pressure Switch Pre-Set: 30-50 PSI

Suction Ports: Drive-over-Suction

ORDERING INFORMATION

CATALOG NUMBER	HP	DESCRIPTION	PIPE TAPPING SIZES			MOTOR VOLTAGE	APPROX. WT. LBS.
			SUCT.	DRIVE	DISCH.		
FLC	1/2	Deep Well Jet	1-1/4"	1"	1"	115/230	44
FLD	3/4	Deep Well Jet	1-1/4"	1"	1"	115/230	45

A Jet Package should be ordered with every FL Series Pump.

NOTE: Pumps installed with a Pro-Source® tank require a 100 PSI relief valve. Pumps installed with a conventional tank require a 75 PSI relief valve. Relief valve must be capable of relieving flow of pump at relief pressure.

Lexan® is a registered trademark of General Electric Co.

All other brand or product names are trademarks or registered trademarks of Pentair Ltd.

FL Series Self-priming convertible jet pumps

Cast Iron

OUTLINE DIMENSIONS

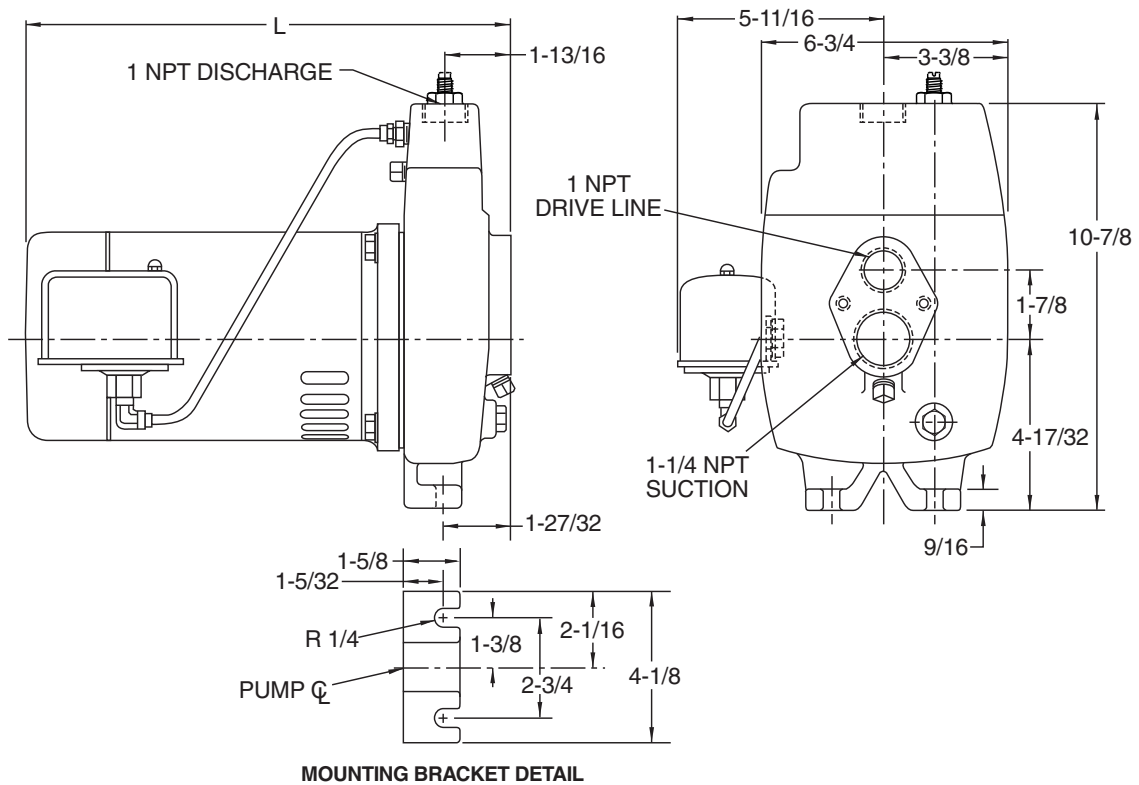

CATALOG NUMBER	L
FLC	11-13/16
FLD	12-9/16

Dimensions (in inches) are for estimating purposes only.

FL Series Self-priming convertible jet pumps

Cast Iron

PUMP PERFORMANCE (CAPACITY IN GALLONS PER MINUTE)
SHALLOW WELL – 5', 10', 15', 20' AND 25' PUMPING DEPTHS

CAT. NO.	HP	DISCHARGE PRESSURE	PUMPING DEPTH TO WATER IN FEET														
			5 FT. LIFT			10 FT. LIFT			15 FT. LIFT			20 FT. LIFT			25 FT. LIFT		
FLC	1/2	JET PACKAGE	10SD	29SD		10SD	29SD		10SD	29SD		10SD	29SD		10SD	29SD	
		Venturi N32P-__	-67B	-66B		-67B	-66B		-67B	-66B		-67B	-66B		-67B	-66B	
		Nozzle J34P-__	-44	-41		-44	-41		-44	-41		-44	-41		-44	-41	
		20 PSI	12.0	9.1		9.7	8.4		12.0	7.3		9.7	6.2		6.7	4.7	
		30 PSI	10.8	9.0		9.5	8.3		10.8	7.2		9.5	6.1		6.7	4.7	
		40 PSI	5.2	7.9		4.2	7.2		5.2	6.3		4.2	5.4		2.5	4.1	
		50 PSI		4.1			3.8			3.3			2.8			2.1	
		60 PSI															
		Shut-off-PSI	53	61		51	58		49	56		47	54		45	52	
FLD	3/4	JET PACKAGE	11SD	10SD	29SD	11SD	10SD	29SD	11SD	10SD	29SD	11SD	10SD	29SD	11SD	10SD	29SD
		Venturi N32P-__	-68B	-67B	-66B	-68B	-67B	-66B	-68B	-67B	-66B	-68B	-67B	-66B	-68B	-67B	-66B
		Nozzle J43P-__	-44	-44	-41	-44	-44	-41	-44	-44	-41	-44	-44	-41	-44	-44	-41
		20 PSI	20.6	14.4	10.1	19.0	13.2	9.3	16.5	11.5	8.1	13.3	9.5	6.9	9.8	6.9	5.3
		30 PSI	19.6	14.3	9.9	18.1	13.1	9.1	15.7	11.4	7.9	13.3	9.5	6.7	9.8	6.9	5.1
		40 PSI	10.3	12.1	9.8	9.4	11.2	9.0	8.2	9.7	7.8	6.4	8.3	6.6	3.1	6.3	5.1
		50 PSI		4.6	7.3		4.3	6.7		3.7	5.8		2.6	4.9		1.0	3.8
		60 PSI			3.5			3.2			2.8			2.4			
		Shut-off-PSI	55	59	70	53	57	66	50	55	64	48	53	61	46	51	59

NOTE: Pumps are supplied with 30-50 pressure switch setting. Cut-in pressure settings are adjustable.

PUMP PERFORMANCE (CAPACITY IN GALLONS PER MINUTE)
DEEP WELL (40 PSI) 4" DOUBLE PIPE

CAT. NO.	HP	JET NO.	USES VENTURI	USES NOZZLE	PUMPING DEPTH IN FEET									MAX. PUMP SHUT-OFF PRESSURE PSI	
					20'	30'	40'	50'	60'	70'	80'	90'	JET AT 20 FT. DEPTH	JET AT MAX. DEPTH	
FLC	1/2	4SD	J32P-24	J34P-41	5.9	4.5	3.4	2.3						68	54
		15SD	J32P-18	J34P-42	4.6	3.9	3.3	2.8	2.3	1.7				84	59
FLD	3/4	54SD	J32P-22	J34P-44	8.0	6.9	5.7	4.8	3.8	3.2				94	70
		55SD	J32P-18	J34P-43	5.0	4.3	3.7	3.2	2.6	2.2	1.8	1.5		96	63

DEEP WELL (40 PSI) 2" SINGLE PIPE

FLC	1/2	8AP	J32P-18	J34P-42	4.7	4.1	3.4	2.5	1.9	1.5			84	58
FLD	3/4	54AP	J32P-22	J34P-44	7.4	6.3	5.2	3.9	2.5	2.0			82	54

DEEP WELL (40 PSI) 3" SINGLE PIPE

FLC	1/2	19CP	J32P-24	J34P-41	5.9	4.5	3.4	2.3					68	54
		16CP	J32P-18	J34P-42	4.6	3.9	3.3	2.8	2.3	1.7			84	59
FLD	3/4	9CP	J32P-26	J34P-41	9.4	8.0	6.6						77	68
		54CP	J32P-22	J34P-44	8.0	6.9	5.7	4.8	3.8	3.2			94	70

Tested and rated in accordance with Water Systems Council Standards.

NOTE: Pumps installed with a Pro-Source® tank require a 100 PSI relief valve. Pumps installed with a conventional tank require a 75 PSI relief valve. Relief valve must be capable of relieving entire flow of pump at relief pressure.

PL Series Convertible deep well jet pumps

Corrosion-resistant



Durability and corrosion resistance are built into every PL Series Pump, due to the rugged fiberglass reinforced thermoplastic pump construction. The engineered composite components are lightweight yet extremely resistant to sand and abrasive wear. The non-corrosive design and exceptional strength assure years of trouble-free operation.

APPLICATIONS

Water systems and sprinkling... for homes, farms and cottages.

SPECIFICATIONS

Pump Body and Seal Plate: Dura-Glas®

Impeller: Noryl®

Nozzle: Noryl

Venturi: Noryl

O-Ring: Buna-N

Clamp: Stainless steel

Shaft: Stainless steel

Diffuser: Reinforced polypropylene with brass wear ring

Shallow Well Jet: Sold separately

Pressure Switch Pre-Set: 30-50 PSI

Suction Ports: Suction-over-Drive

FEATURES

Superior Rustproof Construction: Pump body is Dura-Glas fiberglass reinforced thermoplastic—lightweight, rustproof and exceptionally strong. All components in contact with water are resistant to the corrosive and abrasive forces found in the most aggressive water conditions.

Precision Diffuser: Multi-port, reinforced polypropylene design primes faster and handles more air.

Precision-Molded Impeller: Precision-molded Noryl gives perfect balance and ultra-smoothness for highest performance and efficiency.

Pressure Regulator and Gauge: Performance-proven, simple, built-in pressure regulator is adjustable for best performance on all deep well installations. Pressure gauge included.

Shaft Seal: Stainless steel heat sink provides maximum cooling of the mechanical shaft seal.

Heavy-Duty Motor: Dustproof canopy completely encloses electrical components and provides dust, dirt and insect protection. Ventilating air cannot contaminate vital switching components. Permanently lubricated, heavy-duty ball bearings ensure smooth, quiet operation and extended motor life.

Easy Serviceability: PL pumps are disassembled by removing the stainless steel clamp. Piping does not have to be disturbed. Seal replacement takes only a few minutes. "Control room" motor design makes all components easily accessible.

ORDERING INFORMATION

CATALOG NUMBER	HP	DESCRIPTION	PIPE TAPPING SIZES			MOTOR VOLTAGE	APPROX. WT. LBS.
			SUCT.	DRIVE	DISCH.		
PLC	1/2	Deep Well Jet	1-1/4"	1"	1"	115/230	27
PLD	3/4	Deep Well Jet	1-1/4"	1"	1"	115/230	28
PLE	1	Deep Well Jet	1-1/4"	1"	1"	115/230	30
PLF	1-1/2	Deep Well Jet	1-1/4"	1"	1"	115/230	36

A Jet Package should be ordered with every PL Series pump. Noryl® is a registered trademark of General Electric Co. All other brand or product names are trademarks or registered trademarks of Pentair Ltd.

PL Series Convertible deep well jet pumps

Corrosion-resistant

OUTLINE DIMENSIONS

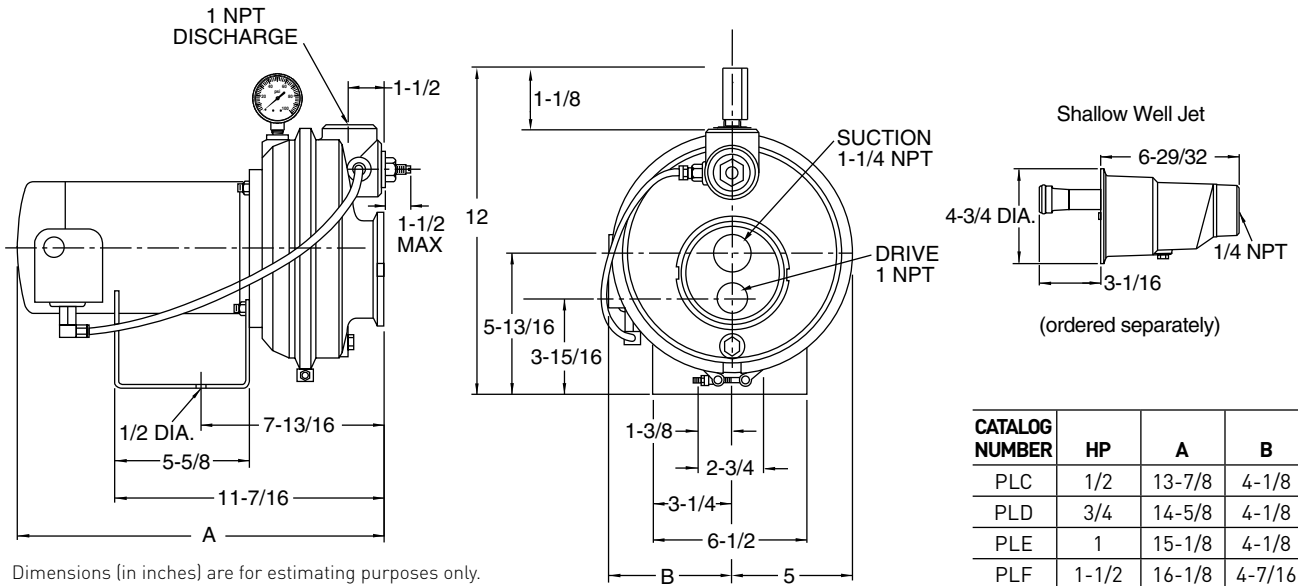

PUMP PERFORMANCE (CAPACITY IN GALLONS PER MINUTE) SHALLOW WELL

CATALOG NUMBER	HP	S.W. JET NUMBER	PRESS. SWITCH SETTING	DYNAMIC SUCTION LIFT FT.	DISCHARGE PRESSURE PSI					SHUT-OFF PRESSURE PSI
					20'	30'	40'	50'	60'	
PLC	1/2	PKG 1 - 21N	30-50	5'	9.5	9.2	9.0	5.8	3.0	72
				10'	8.2	8.0	7.8	5.2	2.3	70
				15'	7.2	6.8	6.8	4.5	1.8	68
				20'	5.7	5.7	5.7	3.8		66
				25'	4.3	4.3	4.3	3.2		62
PLD	3/4	PKG 1 - 22N	30-50	5'	16.2	15.8	15.3	8.7	1.3	62
				10'	14.2	14.0	13.8	7.2		60
				15'	12.2	12.0	11.8	5.3		58
				20'	9.7	9.7	9.2	3.7		55
				25'	7.2	6.8	6.8			52
PLE	1	PKG 1 - 23N	30-50	5'	21.3	21.0	20.7	13.2	4.2	62
				10'	18.8	18.7	18.3	11.1	1.7	60
				15'	16.0	15.8	15.7	8.9		58
				20'	12.8	12.7	12.3	5.7		55
				25'	8.5	8.5	8.5			52
PLF	1-1/2	PKG 1 - 24N	30-50	5'	26.3	26.2	26.2	21.3	7.7	64
				10'	23.7	23.3	23.2	19.2	3.5	62
				15'	20.3	20.2	20.0	16.3		60
				20'	16.2	16.0	15.8	11.2		57
				25'	11.5	11.3	11.3			54

Tested and rated in accordance with Water Systems Council Standards.

NOTE: Pumps installed with a Pro-Source® tank require a 100 PSI relief valve. Pumps installed with a conventional tank require a 75 PSI relief valve. Relief valve must be capable of relieving entire flow of pump at relief pressure.

PL Series Convertible deep well jet pumps

Corrosion-resistant

PUMP PERFORMANCE (CAPACITY IN GALLONS PER MINUTE)
DEEP WELL (40 PSI) 4" DOUBLE PIPE

CAT. NO.	HP	JET NO.	USES VENTURI	USES NOZZLE	PUMPING DEPTH IN FEET										
					20'	30'	40'	50'	60'	70'	80'	90'	100'	110'	120'
PLC	1/2	4SD	J32P-24	J34P-41		4.5	3.5	2.3	1.3						
		10SD	N32P-67B	J34P-44		9.5	7.0	4.5	2.0						
PLD	3/4	4SD	J32P-24	J34P-41		6.5	5.1	4.0	3.0	1.8	0.8				
PLE	1	4SD	J32P-24	J34P-41		8.4	7.3	6.2	5.0	4.1	2.9	2.0	1.1		
PLF	1-1/2	11SD	N32P-68B	J34P-44		11.5	9.4	8.0	6.5	5.3	3.8	2.5	1.1		

PUMP PERFORMANCE (CAPACITY IN GALLONS PER MINUTE)
DEEP WELL (40 PSI) 2" SINGLE PIPE

CAT. NO.	HP	JET NO.	USES VENTURI	USES NOZZLE	PUMPING DEPTH IN FEET										
					20'	30'	40'	50'	60'	70'	80'	90'	100'	110'	120'
PLC	1/2	13AP	J32P-26	J34P-44	5.8	3.8	1.0								
		10AP	J32P-24	J34P-44	4.3	3.0	1.6								
		8AP	J32P-18	J34P-42	3.8	3.3	2.6	2.0	1.5						
PLD	3/4	14AP	J32P-32	J34P-45	9.2	6.7	4.3								
		10AP	J32P-24	J34P-44	6.2	4.8	3.7	2.3	1.2						
		8AP	J32P-18	J34P-42	4.1	3.7	3.1	2.6	2.1	1.6	1.2	0.8			
PLE	1	15AP	J32P-33	J34P-41	12.3	9.2	5.7								
		9AP	J32P-29	J34P-44	10.6	7.4	4.7	2.2							
		8AP	J32P-18	J34P-42	5.0	4.7	4.2	3.8	3.3	2.7	2.3	1.8	1.3		
PLF	1-1/2	16AP	J32P-38	J34P-45	15.3	11.8	8.5	5.2							
		9AP	J32P-29	J34P-44		12.3	9.3	6.4	4.0						
		8AP	J32P-18	J34P-42		5.7	5.0	4.6	4.2	3.7	3.3	2.8	2.4	1.8	1.3

DEEP WELL (40 PSI) 3" SINGLE PIPE

PLC	1/2	25CP	J32P-26	J34P-44	5.8	4.0	2.1								
		19CP	J32P-24	J34P-41		4.5	3.5	2.3	1.3						
PLD	3/4	11CP	J32P-32	J34P-45	9.5	7.0	4.5	2.0							
		19CP	J32P-24	J34P-41		6.5	5.1	4.0	3.0	1.8	0.8				
PLE	1	26CP	J32P-33	J34P-41	13.0	9.8	6.0								
		17CP	J32P-29	J34P-44		11.5	8.0	5.2	2.6						
		19CP	J32P-24	J34P-41		8.4	7.3	6.2	5.0	4.1	2.9	2.0	1.1		
PLF	1-1/2	10CP	J32P-38	J34P-45	16.6	13.3	9.5	6.0							
		15CP	J32P-22	J34P-43		8.6	7.9	6.9	6.2	5.4	4.4	3.2	2.2	1.5	0.9

Tested and rated in accordance with Water Systems Council Standards.

NOTE: Pumps installed with a Pro-Source® tank require a 100 PSI relief valve. Pumps installed with a conventional tank require a 75 PSI relief valve. Relief valve must be capable of relieving entire flow of pump at relief pressure.

Horizontal Multi-Stage HMS Series

Cast Iron

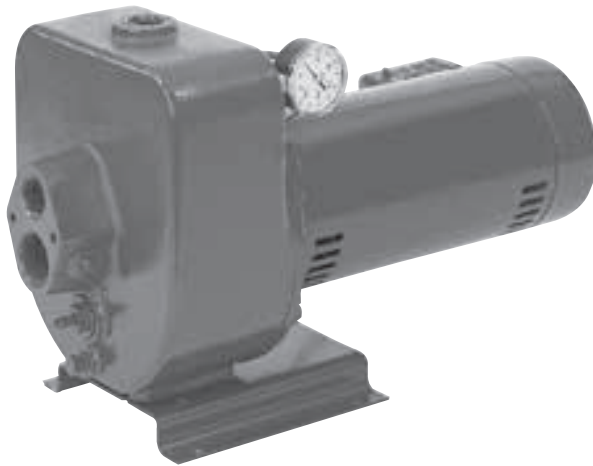

HMS Series Multi-Stage Jet Pumps are the highest performing pumps available in its category. The HMS Series Convertible Jets utilize the built-in regulator, offering easier priming and better range of performance from a complete line of Shallow Well, 4" Double Pipe, 2" and 3" Single Pipe Jet Packages. Pump may also be operated as a self-priming centrifugal (to 25 ft.) to provide a wide range of high pressure applications.

APPLICATIONS

Water systems and sprinkling... for homes, farms and cottages.

SPECIFICATIONS

Body: One-piece rugged cast iron

Pump and Motor Shaft: 416 stainless steel

Impeller: Polycarbonate

Diffuser: Corrosion-resistant cast iron

Pressure Switch Pre-Set: 30-50 PSI

Suction Ports: Drive-over-Suction

FEATURES

Automatic Pressure Regulator: Faster-acting and quieter, design eliminates "hunting" for correct drive pressure. New improved stem and guide are precisely molded to assure efficient, trouble-free performance on all deep wells. See ordering information (deep well only).

Quality Construction: Close-grained cast iron pump body is rugged, one-piece unit, specially treated to resist corrosion. Drain port provided for easy winterizing.

Precision-Machined Diffusers: Assure faster priming.

Mechanical Shaft Seal: Precision-lapped and highly polished carbon-ceramic, stainless steel construction. Internal design guarantees continuous water lubrication for maximum protection.

Polycarbonate Impellers: Precision-molded for perfect balance, and ultra-smooth for highest performance and efficiency.

Motor Windings: Superior insulation materials protect against excessive moisture and contaminants to ensure prolonged motor life.

Dustproof Cover: All electrical components are protected from dirt, dust and insects by a dustproof canopy. Ventilating air cannot contaminate vital switching components. This eliminates the most common cause of motor failure.

Balanced Rotor: Diecast under high pressures for uniform performance and greater efficiency...dynamically balanced.

Heavy-Duty Ball Bearings: Shielded, permanently lubricated bearings are extensively tested to ensure extended life and smooth, quiet operation.

Pump and Motor Shaft: Stainless steel for maximum corrosion resistance; one-piece threaded shaft for positive impeller drive and alignment.

ORDERING INFORMATION

CATALOG NUMBER	HP	DESCRIPTION	PIPE TAPPING SIZES			STAGES	MOTOR VOLTAGE	APPROX. WT. LBS.
			SUCT.	DRIVE	DISCH.			
HMSD	3/4	Deep Well Jet	1-1/4"	1"	1"	2	115/230	50
HMSE	1	Deep Well Jet	1-1/4"	1"	1"	2	115/230	80
HMSF	1-1/2	Deep Well Jet	1-1/4"	1"	1"	2	115/230	85

AUTOMATIC PRESSURE REGULATOR – DEEP WELL

CATALOG NUMBER	DESCRIPTION	APPLICATION	APPROX. WT. LBS.
PKG 107	Regulator, tubing, pipe plug and compression fitting	Required for ALL deep well installations	4

Order pump and pressure regulator, if required, from ordering information tables above.

A Jet Package and the Automatic Pressure Regulator, described above, are required on all deep well installations.

Horizontal Multi-Stage HMS Series

Cast Iron

PUMP PERFORMANCE: SHALLOW WELL

CATALOG NUMBER	HP	JET* NUMBER	USES VENTURI	USES NOZZLE	DISCH. PRESS. PSI	TOTAL SUCTION LIFT FT.				
						5'	10'	15'	20'	25'
HMSD	3/4	PKG 1 - 29SD	N32P-66B	J34P-41	20	9.6	8.2	7.0	5.8	3.9
					30	9.1	7.9	6.5	5.6	3.9
					40	8.8	7.7	6.3	5.6	3.9
					50	8.5	7.6	6.2	5.6	3.9
					60	7.7	7.3	6.2	5.6	3.9
					70	5.5	5.1	4.7	4.2	3.6
					80	3.5	3.1	2.8	2.3	1.9
					Shut-off	102	96	96	96	90
HMSE	1	PKG 1 - 10SD	N32P-67B	J34P-44	20	13.0	11.2	9.8	7.8	5.8
					30	12.5	11.0	9.5	7.6	5.7
					40	12.2	10.9	9.4	7.6	5.7
					50	12.1	10.8	9.2	7.6	5.7
					60	12.0	10.8	9.2	7.6	5.7
					70	10.2	9.6	8.6	7.4	5.7
					80	7.4	6.8	6.2	5.5	4.8
					Shut-off	108	108	108	102	102
HMSE	1-1/2	PKG 1 - 10SD	N32P-67B	J34P-44	20	15.9	13.3	12.2	9.6	7.0
					30	15.6	13.2	12.2	9.5	7.0
					40	15.3	13.1	12.1	9.4	6.9
					50	14.9	13.0	11.9	9.3	6.8
					60	14.4	12.9	11.7	9.2	6.7
					70	13.7	12.7	11.5	9.0	6.6
					80	12.6	12.1	10.8	8.7	6.4
					90	9.5	8.5	7.8	7.2	5.7
					100	5.9	5.0	4.4	3.8	3.2
					Shut-off	120	120	114	114	108

PUMP PERFORMANCE

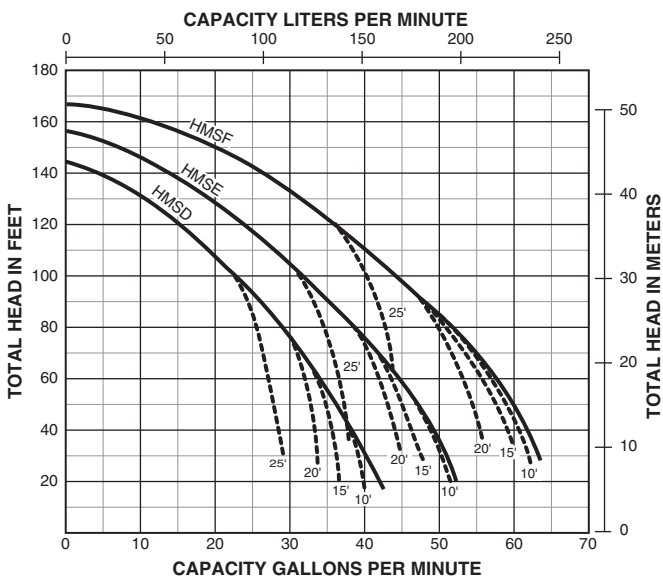

* Order Jet Package separately.

Tested and rated in accordance with Water Systems Council Standards.

NOTE: Pumps installed with a Pro-Source® tank require a 100 PSI relief valve. Pumps installed with a conventional tank require a 75 PSI relief valve. Relief valve must be capable of relieving entire flow of pump at relief pressure.

NOTE: Dotted lines indicate performance reduction at high suction lift.

Horizontal Multi-Stage HMS Series

Cast Iron

PUMP PERFORMANCE (CAPACITY IN GALLONS PER MINUTE) CENTRIFUGAL APPLICATION

CATALOG NUMBER	HP	TOTAL SUCTION LIFT FT.	DISCHARGE PRESSURE PSI					SHUT-OFF PRESSURE PSI
			20'	30'	40'	50'	60'	
HMSD	3/4	5	37	30	24	15	-	60
		10	35	29	21	13	-	60
		15	33	27	19	9	-	60
		20	32	26	17	6	-	60
		25	31	24	15	-	-	60
HMSE	1	5	47	40	33	24	10	65
		10	46	38	31	21	7	65
		15	44	36	28	18	-	65
		20	42	35	26	15	-	65
		25	41	33	24	12	-	65
HMSF	1-1/2	5	60	53	46	36	23	68
		10	58	52	43	33	21	68
		15	56	49	41	30	16	68
		20	55	47	39	27	12	68
		25	54	41	36	25	-	68

Tested and rated in accordance with Water Systems Council Standards.

NOTE: Pumps installed with a Pro-Source® tank require a 100 PSI relief valve. Pumps installed with a conventional tank require a 75 PSI relief valve. Relief valve must be capable of relieving entire flow of pump at relief pressure.

OUTLINE DIMENSIONS

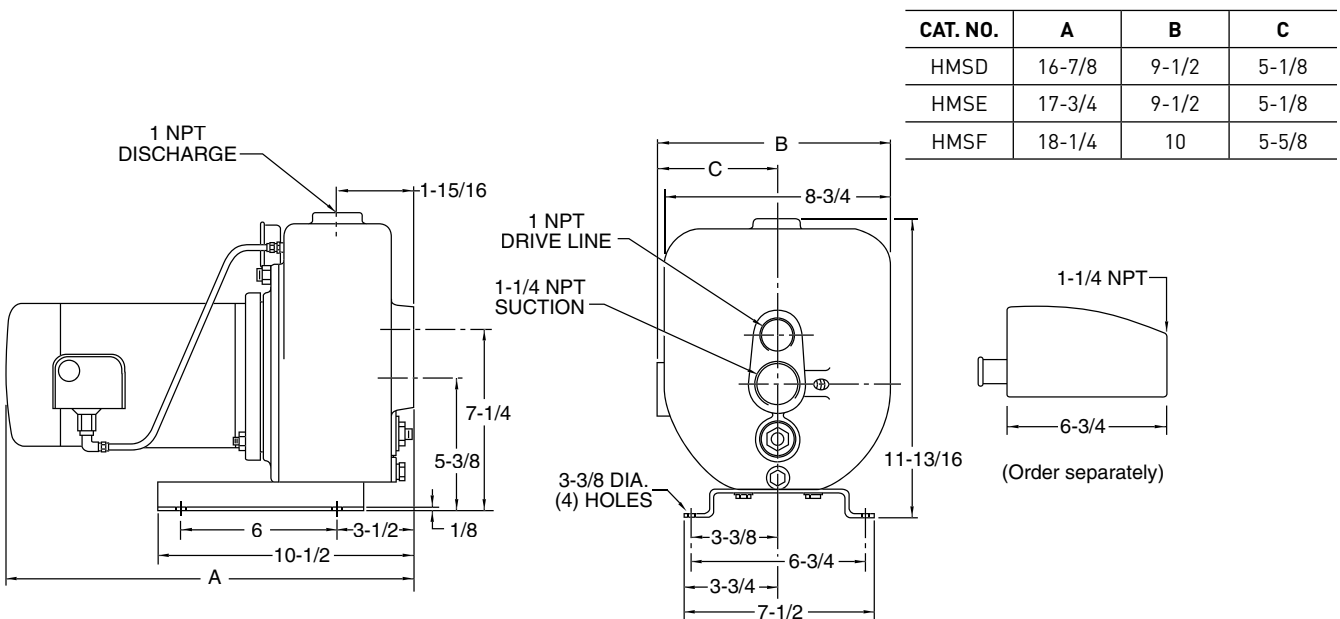

Dimensions (in inches) are for estimating purposes only.

Horizontal Multi-Stage HMS Series

Cast Iron

**PUMP PERFORMANCE (CAPACITY IN GALLONS PER MINUTE)
DEEP WELL 2" SINGLE PIPE: 40 PSI**

CAT. NO.	HP	JET NO.	USES VENTURI	USES NOZZLE	PUMPING DEPTH IN FEET													
					20'	30'	40'	50'	60'	70'	80'	90'	100'	110'	120'	130'	140'	150'
HMSD	3/4	13AP	J32P-26	J34P-44	12.0	10.8	9.6	8.1	6.9	5.5								
		22AP	J32P-22	J34P-43					7.9	6.7	5.5	4.7	3.9	3.0				
		8AP	J32P-18	J34P-42									4.0	3.6	3.1	2.7	2.2	
HMSE	1	5AP	J32P-29	J34P-41	16.3	15.6	14.1	12.0	9.9	8.2	6.0							
		4AP	J32P-24	J34P-41					8.9	7.9	7.0	5.8	4.7	3.6	2.5			
		19AP	J32P-20	J34P-43									4.0	3.2	2.3	1.8	1.3	
HMSE	1-1/2	15AP	J32P-33	J34P-41	20.0	18.5	17.0	13.6	10.4	7.6	5.0							
		9CP	J32P-26	J34P-41					10.6	9.2	8.0	6.0	4.5	3.7	3.0	2.2		
		23AP	J32P-20	J34P-44										4.3	3.5	2.7	2.4	2.0

DEEP WELL 3" SINGLE PIPE: 40 PSI

HMSD	3/4	17CP	J32P-29	J34P-44	12.8	11.5	10.2	8.9	7.6	6.1								
		18CP	J32P-24	J34P-44					7.8	6.9	6.0	5.3	4.5	3.6				
		16CP	Factory Installed										5.0	4.4	3.9	3.4	3.0	2.5
HMSE	1	7CP	J32P-32	J34P-41	17.8	16.2	14.6	13.0	11.4	9.6	7.7							
		9CP	J32P-26	J34P-41					10.7	9.8	9.0	7.9	6.7	5.8	5.0	4.1		
HMSE	1-1/2	10CP	J32P-38	J34P-45	21.7	19.7	17.9	15.9	14.0	11.0	8.0							
		9CP	J32P-26	J34P-41					11.1	10.8	10.6	9.7	8.9	7.5	6.5	5.5		
		19CP	Factory Installed	J34P-41										6.9	6.1	5.3	4.6	4.1

DEEP WELL 4" DOUBLE PIPE: 40 PSI

HMSD	3/4	CK2	J32P-29	J34P-44	12.8	11.5	10.2	8.9	7.6	6.1								
		CK2	J32P-24	J34P-44					7.8	6.9	6.0	5.3	4.5	3.6				
		15SD	Factory Installed										5.0	4.4	3.9	3.4	3.0	2.5
HMSE	1	CK3	J32P-32	J34P-41	17.8	16.2	14.6	13.0	11.4	9.6	7.7							
		CK3	J32P-26	J34P-41					10.7	9.8	9.0	7.9	6.7	5.8	5.0	4.1		
		CK1	J32P-20	J34P-43										5.0	4.5	3.9	3.5	3.0
HMSE	1-1/2	CK4	J32P-38	J34P-45	21.7	19.7	17.9	15.9	14.0	11.0	8.0							
		CK3	J32P-26	J34P-41					11.1	10.8	10.6	9.7	8.9	7.5	6.5	5.5		
		4SD	Factory Installed											6.9	6.1	5.3	4.6	4.1

Tested and rated in accordance with Water Systems Council Standards.

NOTE: Pumps installed with a Pro-Source® tank require a 100 PSI relief valve. Pumps installed with a conventional tank require a 75 PSI relief valve. Relief valve must be capable of relieving entire flow of pump at relief pressure.

PRO-SOURCE® Jet/Tank Packages

Cast Iron

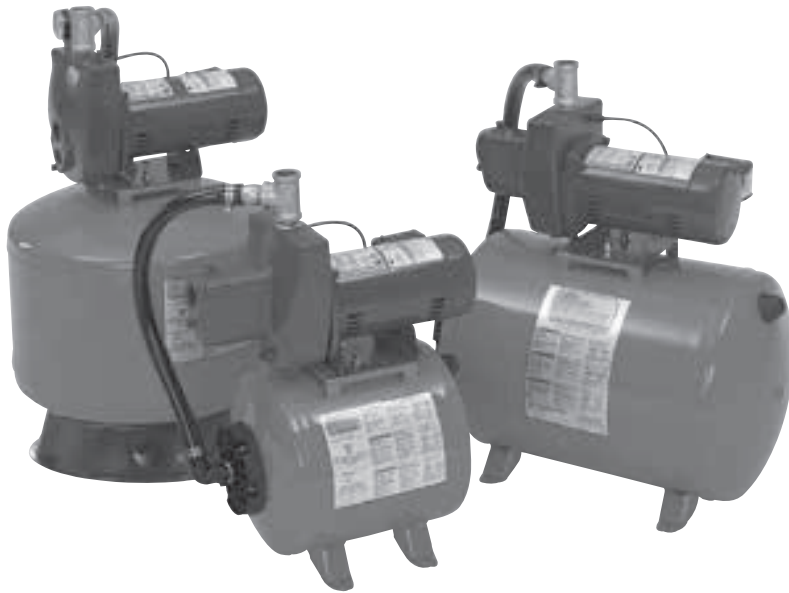

Pro-Source™ Water System Packages are handy and economical pump/tank packages for the professional contractor. The Pro-Source Water System Packages utilize the ProJet™ cast iron jet pumps and the dependable

Pro-Source quality pressurized steel tanks. Plumbing connections are made using galvanized fittings and 3-ply nylon reinforced vinyl tubing with stainless steel hose clamps. Ideal for installations where there is limited space.

APPLICATIONS

Water systems, sprinkling and pressure boosting...for homes, farms and cottages.

SPECIFICATIONS

Max. Liquid Temperature: 120°F (49°C)

Max. Inlet Pressure: 50 PSI

Pump Discharge PSI: Not to exceed 100 PSI

FEATURES

ProJet™ Jet Pumps

Body: Close-grained cast iron

Nozzle: High-strength polycarbonate

Venturi: Polycarbonate

Impeller: Noryl®

Diffuser: Reinforced polypropylene

Shaft: 416 stainless steel

Base: Steel, 10 gauge

Pro-Source™ Pressurized Tanks

Shell: Heavy-gauge steel

Base: High-impact composite; polypropylene

Finish: Baked-on polyester paint

Water Cell: PVC made from FDA listed material

Flange: Reinforced polypropylene

Connections: Galvanized

Tubing: 3-ply nylon reinforced vinyl with stainless steel hose clamps

ORDERING INFORMATION

JET/TANK CATALOG NUMBER	HP	JET PUMP TYPE	PUMP CAT. NO.	TANK CAT. NO.	TANK STYLE	TANK CAPACITY U.S. GAL.	DRAWDOWN @ 30-50 PSI SWITCH SET.	CONNECTION SIZE FEMALE	APPROX. WT. LBS.
SNCP15H	1/2	Shallow Well	SNC	PS6H-S05	Horizontal	6	1.8	3/4" NPT	85
SNCP42	1/2	Shallow Well	SNC	PS19S-T02	Vertical	19	5.8	1" NPT	120
SLCP42*	1/2	Deep Well	SLC	PS19S-T02	Vertical	19	5.8	1" NPT	127
SLDP42*	3/4	Deep Well	SLD	PS19S-T02	Vertical	19	5.8	1" NPT	130

*Shallow well/deep well Jet Package included.

Noryl® is a registered trademark of General Electric Co. All other brand or product names are trademarks or registered trademarks of Pentair Ltd.

PRO-SOURCE® Jet/Tank Packages

Cast Iron

OUTLINE DIMENSIONS: SHALLOW WELL

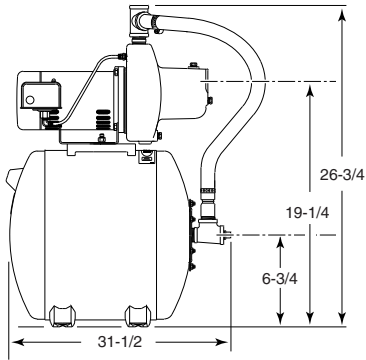

OUTLINE DIMENSIONS: DEEP WELL

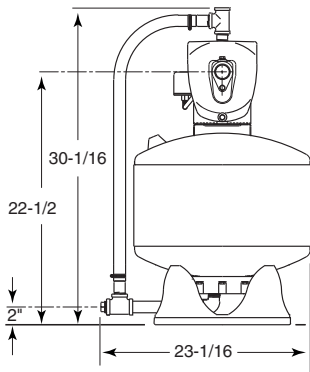
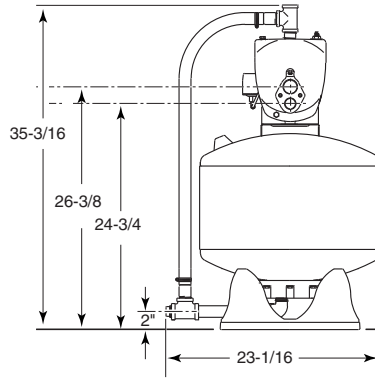

Dimensions (in inches) are for estimating purposes only.

PUMP PERFORMANCE

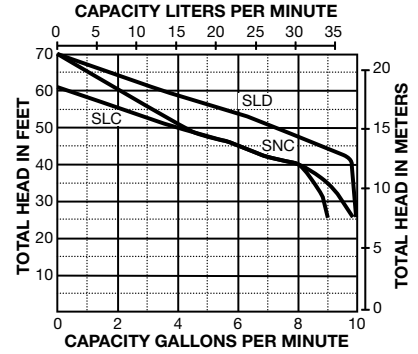

TANK DRAWDOWN (IN GALLONS)

TANK CATALOG NUMBER	PRESSURE SWITCH SETTING		
	20-40	30-50	40-60
PS6H-S05	2.2	1.8	1.6
PS19S-T02	6.9	5.8	5.0

SHALLOW WELL PUMP PERFORMANCE (CAPACITY IN GALLONS PER MINUTE)

CATALOG NUMBER	HP	TOTAL SUCTION LIFT	DISCHARGE PRESSURE (PSI)			SHUT-OFF PSI
			30	40	50	
SNC	1/2	5'	9.7	7.9	4.5	67
		10'	8.3	7.2	3.8	65
		15'	7.4	6.4	3.1	62
		20'	5.9	5.6	2.7	60
		25'	4.3	4.1	1.8	58

NOTE: Pump will operate at all depths shown, with pressure switch set at 30-50 PSI. Pumps installed with Pro-Source® tank require a 100 PSI relief valve.

PUMP PERFORMANCE (CAPACITY IN GALLONS PER MINUTE)

CATALOG NUMBER	HP	USE VENTURI/NOZZLE	EJECTOR PKG.*	SHALLOW WELL JET COMBINATIONS							
				TOTAL SUCTION LIFT	DISCHARGE PRESSURE (PSI)				SHUT-OFF PSI		
					30	40	50	60			
SLC	1/2	N32P-66B J34P-41	29SD	5'	9.0	7.9	4.1	-	61		
				15'	7.2	6.3	3.3	-	56		
				25'	4.7	4.1	2.1	-	52		
SLD	3/4	N32P-66B J34P-41	29SD	5'	9.9	9.8	7.3	3.5	70		
				15'	7.9	7.8	5.8	2.8	64		
				25'	5.1	5.0	3.8	1.7	59		
CATALOG NUMBER	HP	USE VENTURI/NOZZLE	EJECTOR PKG.*	DEEP WELL JET COMBINATIONS							
				DISCHARGE PRESSURE PSI	DISCHARGE PRESSURE (PSI)					SHUT-OFF MIN. DEPTH	
					30	40	50	60	70		80
SLC	1/2	J32P-24 J34P-41	4SD	30	7.3	5.8	4.5	3.3	2.3	-	68
				40	4.5	3.4	2.3	-	-	-	
SLD	3/4	J32P-24 J34P-41	4SD	30	8.9	7.3	6.4	5.0	4.0	2.5	75
				40	6.5	5.1	4.0	3.0	1.8	0.8	

MS Series

Cast Iron



The MS Series Vertical Jet Pumps are the industry standard deep well jet pumps for over-the-well “bolt-on” installations.

The MS Series Jet Pumps include the pre-plumbed external automatic regulator, pressure gauge, pressure switch, and a complete line of casing adapters to drive the 4” double pipe or 2” and 3” single pipe jet packages.

APPLICATIONS

Water systems and sprinkling...for homes, farms and cottages.

SPECIFICATIONS

Body: Rugged cast iron

Pump and Motor Shaft: 416 stainless steel

Impellers: Noryl®

Diffuser: Close-grained cast iron

FEATURES

Automatic Pressure Regulator: Faster-acting and quieter, design eliminates “hunting” for correct drive pressure. New, improved stem and guide are precisely molded to assure efficient, trouble-free performance on all deep wells.

Quality Construction: Precision-machined, close-grained cast iron pump body and base are specially treated to resist corrosion.

Noryl Impellers: Precision-molded for perfect balance, and ultra-smooth for highest performance and efficiency.

Pressure Switch: High quality. Differential and cut-in/cut-out pressure settings are adjustable.

Motor Windings: Superior insulation materials protect against excessive moisture and contaminants to ensure prolonged motor life.

Mechanical Shaft Seal: Precision-lapped and highly polished carbon-ceramic, stainless steel construction. Internal design guarantees continuous water lubrication for maximum protection.

Dustproof Cover: All electrical components are protected from dirt, dust and insects by a dustproof canopy. Ventilating air cannot contaminate vital switching components. This eliminates the most common cause of motor failure.

Balanced Rotor: Rotor is diecast under high pressures for uniform performance and greater efficiency...dynamically balanced.

Heavy-Duty Ball Bearings: Permanently lubricated sealed bearings are extensively tested to ensure extended life and smooth, quiet operation.

Pump and Motor Shaft: Stainless steel for maximum corrosion resistance; one-piece threaded shaft for positive impeller drive and alignment.

ORDERING INFORMATION

CATALOG NUMBER	HP	DESCRIPTION	MAX. PRESS. REG. SETTING	PIPE TAPPING SIZES			MOTOR VOLTAGE	APPROX. WT. LBS.
				SUCT.	DRIVE	DISCH.		
MSD	3/4	Deep Well Jet	40 PSI	1-1/4"	1"	1"	115/230	67
MSE	1	Deep Well Jet	60 PSI	1-1/4"	1-1/4"	1"	115/230	73
MSF	1-1/2	Deep Well Jet	85 PSI	1-1/4"	1-1/4"	1"	230	120
MSG	2	Deep Well Jet	95 PSI	1-1/4"	1-1/4"	1"	230	125

ADAPTER FLANGE

CATALOG NUMBER	DESCRIPTION	USED WITH
J216-26	1-1/4" x 1"	Offset single pipe, 4" double pipe through 3/4 HP
J216-27	1-1/4" x 1-1/4"	4" double pipe 1, 1-1/2 and 2 HP

Order pump from ordering information table above. A Jet Package should be ordered with every MS Series Pump. All installations require an appropriate size adapter flange or casing adapter if bolt-on feature is desired.

Noryl® is registered trademark of General Electric Co.

All other brand or product names are trademarks or registered trademarks of Pentair Ltd.

MS Series

Cast Iron

OUTLINE DIMENSION

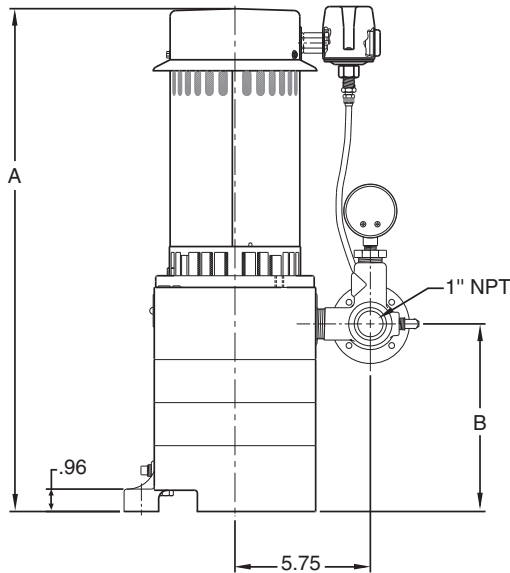

CAT. NO.	A	B
MSD	17-5/16	5-5/8
MSE	18-3/8	5-5/8
MSF	20-7/16	7-1/2
MSG	20-15/16	7-1/2

Dimensions (in inches) are for estimating purposes only.

PUMP PERFORMANCE (CAPACITY IN GALLONS PER MINUTE) DEEP WELL (40 PSI) 4" DOUBLE PIPE

CAT. NO.	HP	JET NO.	USES VENTURI	USES NOZZLE	PUMPING DEPTH IN FEET																	MAX. PUMP SHUT-OFF PRESS. PSI							
					30'	40'	50'	60'	70'	80'	90'	100'	110'	120'	130'	140'	180'	200'	220'	240'	260'	280'	300'	320'	JET AT MIN. DEPTH	JET AT MAX. DEPTH			
MSD	3/4	23SD	J32P-24	J34P-42	10.2	8.4	6.8	5.8	4.5	3.1	2.1	1.1															80	46	
		15SD	J32P-18	J34P-42	5.5	5.4	5.3	5.2	4.7	4.3	4.1	3.7	3.1	2.7	2.3	1.9												137	75
MSE	1	23SD	J32P-24	J34P-42	12.1	11.7	11.6	11.1	10.2	9.2	7.8	6.4	5.0	4.0	3.0													120	76
		15SD	J32P-18	J34P-42	5.5	5.5	5.5	5.4	5.3	5.3	5.2	5.1	5.1	5.0	4.8	4.5	3.3	2.7	2.0	1.3	1.0							200	97
MSF	1-1/2	23SD	J32P-24	J34P-42	12.2	12.2	12.2	12.2	11.7	11.3	10.7	9.9	9.0	8.3	7.0	4.0	1.3											164	95
		15SD	J32P-18	J34P-42	5.5	5.5	5.5	5.5	5.5	5.5	5.3	5.3	5.2	5.1	5.1	5.0	4.8	4.7	4.5	4.3	4.0	3.3	2.7				314	172	
MSG	2	23SD	J32P-24	J34P-42	12.2	12.2	12.2	12.2	11.8	11.3	11.2	11.1	11.0	10.0	8.7	7.0	4.0	2.0										195	110
		15SD	J32P-18	J34P-42	5.5	5.5	5.5	5.5	5.5	5.5	5.3	5.3	5.2	5.1	5.1	5.0	5.0	4.8	4.8	4.5	4.3	4.0	3.3	2.7			314	172	

Tested and rated in accordance with Water Systems Council Standards.

NOTE: Pumps installed with a Pro-Source® tank require a 100 PSI relief valve. Pumps installed with a conventional tank require a 75 PSI relief valve. Relief valve must be capable of relieving entire flow of pump at relief pressure.

SSJ Series

Cast Iron



The SSJ Series Vertical Jet Pumps are the industry standard deep well jet pumps for over-the-well "bolt-on" installations.

The SSJ Series Jet Pumps include the pre-plumbed external automatic regulator, pressure gauge, pressure switch, and a complete line of casing adapters to drive the 4" double pipe or 2" and 3" single pipe jet packages.

APPLICATIONS

Water systems and sprinkling...for homes, farms and cottages.

SPECIFICATIONS

Body: Rugged cast iron

Pump and Motor Shaft: Stainless steel

Impellers: Noryl®

Diffuser: Heavy-duty cast iron

FEATURES

Automatic Pressure Regulator: Faster-acting, quieter design eliminates "hunting" for correct drive pressure. New, improved stem and guide are precisely molded to assure efficient, trouble-free performance on all deep wells.

Quality Construction: Precision-machined, close-grained cast iron pump body and base are specially treated to resist corrosion.

Noryl Impellers: Precision-molded for perfect balance, and ultra-smooth for highest performance and efficiency.

Pressure Switch: High quality. Differential and cut-in/cut-out pressure settings are adjustable.

Dustproof Cover: All electrical components are protected from dirt, dust and insects by a dustproof canopy. Ventilating air cannot contaminate vital switching components. This eliminates the most common cause of motor failure.

Motor Windings: Superior insulation materials protect against excessive moisture and contaminants to ensure prolonged motor life.

Balanced Rotor: Diecast under high pressures for uniform performance and greater efficiency...dynamically balanced.

Heavy-Duty Ball Bearings: Shielded, permanently lubricated bearings are extensively tested to ensure extended life and smooth, quiet operation.

Pump and Motor Shaft: Stainless steel for maximum corrosion resistance; one-piece threaded shaft for positive impeller drive and alignment.

ORDERING INFORMATION

CATALOG NUMBER	HP	DESCRIPTION	PIPE TAPPING SIZES			MOTOR VOLTAGE	APPROX. WT. LBS.
			SUCT.	DRIVE	DISCH.		
SSJC	1/2	Deep Well Jet	1-1/4"	1"	1"	115/230	53
SSJD	3/4	Deep Well Jet	1-1/4"	1"	1"	115/230	63
SSJE	1	Deep Well Jet	1-1/4"	1"	1"	115/230	65

ADAPTER FLANGE*

CATALOG NUMBER	DESCRIPTION	USED WITH
J216-26	1-1/4" x 1"	Offset single pipe and 4" double pipe

*Required for all 4" double pipe or offset installations.

NOTE: Order pump from ordering information table above. A Jet Package should be ordered with every SSJ Series Pump. All installations require an appropriate size adapter flange or casing adapter.

Noryl® is registered trademark of General Electric Co.

All other brand or product names are trademarks or registered trademarks of Pentair Ltd.

SSJ Series

Cast Iron

OUTLINE DIMENSIONS

CAT. NO.	A
SSJC	14-1/2
SSJD	15-1/8
SSJE	16-3/16

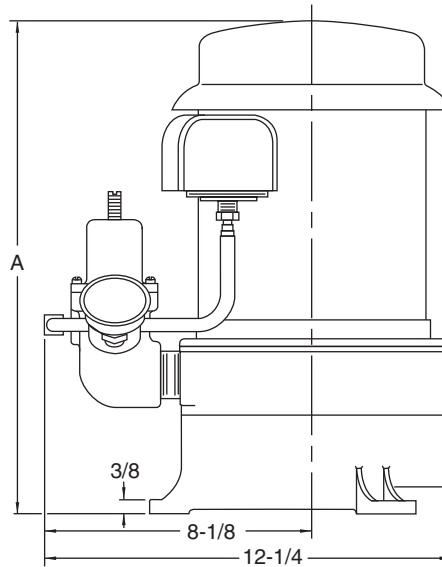

Dimensions (in inches) are for estimating purposes only.

PUMP PERFORMANCE (CAPACITY IN GALLONS PER MINUTE) DEEP WELL (40 PSI) 4" DOUBLE PIPE

CAT. NO.	HP	JET NO.	USES VENTURI	USES NOZZLE	PUMPING DEPTH IN FEET											MAX. PUMP SHUT-OFF PRESS. PSI		
					20'	30'	40'	50'	60'	70'	80'	90'	100'	110'	120'	130'	JET AT MIN. DEPTH	JET AT MAX. DEPTH
SSJC	1/2	15SD	J32P-18	J34P-42		4.8	4.3	3.7	3.0	2.4	1.8	1.5	1.0	0.5			91	50
		CK4	J32P-32	J34P-35	9.5	7.0	4.5	2.0									62	44
		4SD	J32P-24	J34P-41		6.5	5.1	4.0	3.0	1.8	0.8							75
SSJD	3/4	CK1	J32P-22	J34P-43		8.3	7.4	6.3	5.3	3.8	3.5	2.6	1.8	1.0			88	46
		CK3	J32P-32	J34P-41		10.0	6.4	3.0									57	46
		4SD	J32P-24	J34P-41		8.6	7.5	6.5	5.2	4.0	2.9	1.8	0.8				93	51
SSJE	1	CK1	J32P-22	J34P-43		8.6	7.8	6.6	5.6	4.5	3.6	2.8	2.3	1.7	1.1	0.6	98	47
		CK4	J32P-28	J34P-45		11.4	10.7	9.6	8.3	7.0	5.0	3.3	1.6				102	48
		CK4	J32P-38	J34P-45	17.0	13.2	9.5	5.8	2.2								66	44

Tested and rated in accordance with Water Systems Council Standards.

NOTE: Pumps installed with a Pro-Source® tank require a 100 PSI relief valve. Pumps installed with a conventional tank require a 75 PSI relief valve. Relief valve must be capable of relieving entire flow of pump at relief pressure.

SSJ Series

Cast Iron

**PUMP PERFORMANCE (CAPACITY IN GALLONS PER MINUTE)
DEEP WELL (40 PSI) 2" SINGLE PIPE**

CAT. NO.	HP	JET NO.	USES VENTURI	USES NOZZLE	PUMPING DEPTH IN FEET											MAX. PUMP SHUT-OFF PRESS. PSI			
					20'	30'	40'	50'	60'	70'	80'	90'	100'	110'	120'	130'	JET AT MIN. DEPTH	JET AT MAX. DEPTH	
SSJC	1/2	14AP	J32P-32	J34P-45	9.2	6.7	4.3											61	49
		10AP	J32P-24	J34P-44		6.2	4.8	3.7	2.3	1.2								71	47
		8AP	J32P-18	J34P-42		4.1	3.7	3.1	2.6	2.1	1.6	1.2	0.8					94	53
SSJD	3/4	15AP	J32P-33	J34P-41	12.3	9.2	5.7											57	48
		9AP	J32P-29	J34P-44		10.6	7.4	4.7	2.3									64	47
		8AP	J32P-18	J34P-42		5.0	4.7	4.2	3.8	3.3	3.3	2.3	1.8	1.3				109	62
SSJE	1	16AP	J32P-38	J34P-45	15.3	11.8	8.5	5.2										65	48
		9AP	J32P-29	J34P-44		12.3	9.3	6.4	4.0									72	53
		8AP	J32P-18	J34P-42		5.7	5.0	4.6	4.2	3.7	3.3	2.8	2.4	1.8	1.3			124	66

DEEP WELL (40 PSI) 3" SINGLE PIPE

SSJC	1/2	19CP	J32P-24	J34P-41		6.5	5.1	4.0	3.0	1.8	0.8							75	45
		16CP	J32P-18	J34P-42		4.8	4.3	3.7	3.0	2.4	1.8	1.5	1.0	0.5				91	50
		11CP	J32P-32	J34P-45	9.5	7.0	4.5	2.0										62	44
SSJD	3/4	26CP	J32P-33	J34P-41	13.0	9.8	6.0											58	49
		19CP	J32P-24	J34P-41		8.6	7.5	6.5	5.2	4.0	2.9	1.8	0.8					93	51
		17CP	J32P-29	J34P-44		11.5	8.0	5.2	2.6									66	48
		15CP	J32P-22	J34P-43		8.3	7.4	6.3	5.3	3.8	3.5	2.6	1.8	0.1				88	46
SSJE	1	19CP	J32P-24	J34P-41		7.9	7.5	7.2	6.5	5.6	4.4	2.8						105	69
		15CP	J32P-22	J34P-43		8.6	7.8	6.6	5.6	4.5	3.6	2.8	2.3	1.7	1.1	0.6		98	47
		10CP	J32P-38	J34P-45	17.0	13.2	9.5	5.8	2.2									66	44

Tested and rated in accordance with Water Systems Council Standards.

NOTE: Pumps installed with a Pro-Source® tank require a 100 PSI relief valve. Pumps installed with a conventional tank require a 75 PSI relief valve. Relief valve must be capable of relieving entire flow of pump at relief pressure.

Jet Packages & Accessories

A jet package should be ordered with every convertible deep well jet pump.

ORDERING INFORMATION

Package	Jet Number	Used with Pump Series
SHALLOW WELL AND 4" DEEP WELL DOUBLE PIPE		
PKG 1 - [] [] SD For shallow well applications For all 4" double pipe applications	PKG 1-4SD	SL, HL, FL, HMS
	PKG 1-10SD	SL, HL, FL, HMS
	PKG 1-11SD	SL, HL, FL, HMS
	PKG 1-12SD	SL, HL, FL, HMS
	PKG 1-15SD	SL, HL, FL, HMS
	PKG 1-23SD	MS, PL
	PKG 1-27SD	SL, HL, FL
	PKG 1-29SD	SL, HL, FL, HMS
	PKG 1-54SD	SL, HL, FL
	PKG 1-55SD	SL, HL, FL
	PKG 1-60SD	SL, HL
SHALLOW WELL AND 4" DEEP WELL DOUBLE PIPE - KITS		
PKG CK [] Same as SD jets above, with three (3) venturis	PKG CK1	SL, HL, HMS, SSJ
	PKG CK2	SL, HL, HMS, SSJ
	PKG CK3	SL, HL, HMS, SSJ, FL
	PKG CK4	HMS, SSJ
	PKG CK5	SL, HL, HMS, SSJ
4" DEEP WELL DOUBLE PIPE WITH ACCESSORY PACKAGES		
PKG 2A - [] [] SD	PKG 2A-4SD	SL, HL, FL, HMS
	PKG 2A-15SD	SL, HL, FL, HMS
	PKG 2A-23SD	MS, PL
	PKG 2A-54SD	SL, HL, FL
	PKG 2A-55SD	SL, HL, FL
PL SERIES PLASTIC SHALLOW WELL JET PACKAGES		
PKG 1 - [] [] N For all shallow well applications	PKG 1-21N	PL
	PKG 1-22N	PL
	PKG 1-23N	PL
	PKG 1-24N	PL

Continued On Next Page.

ORDERING INFORMATION

ACCESSORY PACKAGE		
Catalog Number	Description	Approx. Wt. Lbs.
PKG 2A	Poly Pipe and Foot Valve Kit (1-1/4" Brass)	3



PKG 1- [] [] SD
SHALLOW WELL & DEEP WELL

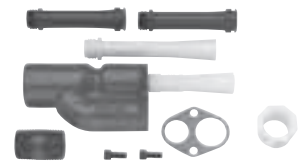

PKG CK []



PKG 2A- [] [] SD
DOUBLE PIPE



PKG 1- [] [] N
PL SHALLOW WELL



PKG 2A
ACCESSORY PACKAGE

Jet Packages & Accessories

A jet package should be ordered with every convertible deep well jet pump.

ORDERING INFORMATION (CONT'D.)

Package	Jet Number	Suction Tapping	Used with Pump Series
2" SINGLE PIPE*			
PKG 1**- <input type="checkbox"/> <input type="checkbox"/> AP PKG 1- <input type="checkbox"/> <input type="checkbox"/> APB (4 lbs.) Jet with built-in check valve For all 2" single pipe deep well applications	PKG 1-54 AP	1-1/4" M and 1" F	SL, HL, FL
	PKG 1-23 AP		HMS
	PKG 1-22 AP		HMS
	PKG 1-18 AP		HMS
	PKG 1-19 AP		HMS
	PKG 1-16 AP & APB		PL, SSJ
	PKG 1-15 AP		PL, HMS, SSJ
	PKG 1-14 AP		PL, SSJ
	PKG 1-13 AP		PL, HMS
	PKG 1-12 AP & APB		MS
	PKG 1-10 AP & APB		SL, HL, PL, SSJ
	PKG 1-9 AP & APB		SL, HL, PL, SSJ
	PKG 1-8 AP & APB		SL, HL, PL, HMS, SSJ, MS, FL
	PKG 1-7 AP & APB		HMS
	PKG 1-5 AP		HMS
PKG 1-4 AP	HMS		
PKG 1-2 AP	HMS		
3" SINGLE PIPE			
PKG 1** <input type="checkbox"/> <input type="checkbox"/> CP (6 lbs.) Jet with built-in check valve For all 3" single pipe deep well applications	PKG 1-57 CP	1-1/4" M and 1" F	SL, HL
	PKG 1-54 CP		SL, HL, FL
	PKG 1-26 CP		PL, SSJ
	PKG 1-25 CP		PL
	PKG 1-23 CP		MS
	PKG 1-22 CP		HMS, MS
	PKG 1-19 CP		SL, HL, PL, HMS, SSJ, FL
	PKG 1-18 CP		SL, HL, HMS
	PKG 1-17 CP		PL, HMS, SSJ, MS
	PKG 1-16 CP		SL, HL, HMS, SSJ, MS, FL
	PKG 1-15 CP		PL, SSJ
	PKG 1-11 CP		PL, SSJ
	PKG 1-10 CP		PL, HMS
PKG 1-9 CP	SL, HL, HMS, FL		
PKG 1-7 CP	HMS		

*Order one (1) U11-1 turned coupling for each length of drop pipe.

**For casing adapter, please see following page.

ORDERING INFORMATION

TURNUED COUPLING

Catalog Number	Description	Approx. Wt. Lbs.
U11-1	Turned Coupling (1-1/4" NPT)	1



PKG 1- **AP**
2" SINGLE PIPE CAST IRON

OR

PKG 1- **APB**
2" SINGLE PIPE BRASS

OR

PKG 1- **CP**
3" SINGLE PIPE



PKG U11-1
TURNED COUPLING

Jet Packages & Accessories



View A
Vertical - Straight Offset
Casing Adapter



View B
Vertical - Bolt-on
Casing Adapter



View C
Horizontal - Right Angle
Casing Adapter
Drive-Over-Suction



View D
Horizontal - Right Angle
Casing Adapter
Suction-Over-Drive

ACCESSORIES

Catalog Number	View	Description	Approx. Wt. Lbs.	Use with Pump Series
CASING ADAPTERS				
J216-13A	A	2" vertical - straight offset	6	General Usage
J216-14A	A	3" vertical - straight offset	8	General Usage
J216-21	B	2" vertical - bolt-on	6	SSJ, MS
J216-23	B	3" vertical - bolt-on	7	SSJ, MS
J216-16A	C	2" horizontal - right angle - drive-over-suction	7	FL, HMS
J216-18A	C	3" horizontal - right angle - drive-over-suction	9	FL, HMS
J37-4	-	Offset nipple (1" NPT x 4-3/4")	1	General Usage
J216-29B	-	2" concentric pipe - pitless adapter	6	SSJ, MS
J216-42	-	2" concentric pipe - pitless adapter	6	FL, HMS
J216-44	D	2" horizontal - right angle - suction-over-drive	7	SL, HL
FOOT VALVES				
U212-28	E	3/4" foot valve and strainer	1	
U212-93	E	1" foot valve and strainer	1	
U212-94	E	1-1/4" foot valve and strainer	2	
U212-92	E	1-1/2" foot valve and strainer	3	
U212-16	E	2" foot valve and strainer	3	
PRESSURE REGULATOR				
PKG 107	F	Regulator, tubing, pipe plug and compression fitting	4	

View E
Foot
Valves



View F
Pressure
Regulator



Jet Packages & Accessories

ACCESSORIES (CONT'D.)

AIR VOLUME CONTROLS		
Catalog Number	Description	Approx. Wt. Lbs.
U238-5A	Sta-Rite AVC, 1/4" compression fitting for copper tube, nipple, instruction sheet, jet type	1
U238-5B	Sta-Rite AVC, 1/4" compression fitting for plastic tube, nipple, instruction sheet, jet type	1
J238-10B	Sta-Rite AVC, 1/4" plastic tubing, compression fittings, reducer bushing and instruction sheet	3
E238-2	Air volume control – submersible	1
U238-4	AVC bulk. No fittings.	1
U238-5E	AVC boxed. No fittings or nipple.	1
U78-774P	Plastic AVC reducer bushing, 1-1/4" x 1/4"	1
TANK MOUNTING PACKAGES –PRO-SOURCE® TANKS		
PKG 111	For tank mounting PL and PN Series jet pumps	2
PKG 112	For tank mounting HN, SN, FN, HL, SL, and FL Series Jet Pumps	2
PKG 198	Jet Pump to Tank Mounting Bracket	3
PKG 207	Pump-to-Tank Fitting Package – all galvanized fittings	4
REVERSING ADAPTER		
PKG 108	Adapter, gasket, capscrews, 1" x 1-1/4"	4
PRESSURE GAUGES		
U239-2	Pressure gauge, bottom mount 1/4", 0-100 PSI	1
U239-3	Pressure gauge, bottom mount 1/8", 0-100 PSI	1
U239-3A	U239-3 with 1/4" x 1/8" reducer bushing	1
U239-8	Pressure gauge, bottom mount 1/4", 0-200 PSI	1
U78-107DT	Reducer bushing for U239-3 1/4" x 1/8"	1



U238-5
Air Volume Controls
(Jet pump type)



E238-2
Air Volume Control
(Submersible type)



Reducer Bushing



Tank Mounting Packages



PKG 108
Reversing Adapter
Drive over suction to suction over drive

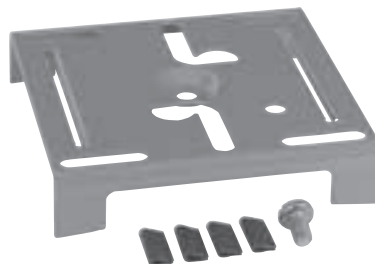

PKG 198
Universal Jet Pump to Tank
Mounting Bracket



Pressure Gauge

PRO-SOURCE® Composite Fibrewound Tanks



Built Tough...for Quality

Every Pro-Source® Composite tank utilizes a durable, FDA approved air cell which is resistant to chlorine and will not promote taste or odor problems associated with iron bacteria that may be present in the water supply.

Built Tough...for Durability

Each tank is wrapped with more than three miles of overlapping, continuous fiberglass strands, sealed with high-grade epoxy resin, then oven-cured. Tough composite construction means longer lasting tanks that will not rust, corrode, dent or scratch.

Built Tough...for Easy Installation and Service

Not only is composite construction tougher, it's also more lightweight...as little as half the weight of steel tanks. Installation is faster, easier and can be handled by one person. Repairable with the tank installed.

NSF/ANSI 61
Drinking Water

ORDERING INFORMATION

Catalog Number	Tank Capacity Gal./Liter	Tank Diameter Inch / cm	Tank Height Inch / cm	Discharge Tapping Inch / cm	Water Yield Per Pump Cycle Pressure Switch Setting		
					20-40 Gal./ Liter	30-50 Gal./ Liter	40-60 Gal./ Liter
PSC-14-4	14.5 / 55	16 / 41	28.2 / 71.6	1 / 2.5	4.9 / 18.7	4.4 / 16.5	3.8 / 14.3
PSC-20-6	19.8 / 75	16 / 41	34.1 / 86.6	1 / 2.5	6.7 / 25.5	5.9 / 22.5	5.1 / 19.5
PSC-30-9	29.5 / 112	16 / 41	46.3 / 117.6	1 / 2.5	10.0 / 38.1	8.9 / 33.5	7.7 / 29.1
PSC-40-12	40.3 / 153	16 / 41	59.0 / 149.9	1 / 2.5	13.7 / 52.0	12.1 / 45.8	10.5 / 39.8
PSC-48-14	47.1 / 178	21 / 53	43.6 / 110.7	1.25 / 3.1	16.0 / 60.5	14.1 / 53.5	12.2 / 46.3
PSC-60-20	60 / 227	24 / 61	44.4 / 112.8	1.25 / 3.1	20.4 / 77.2	18.0 / 68.1	15.6 / 59.0
PSC-80-23	79.6 / 301	21 / 53	65.5 / 166.4	1.25 / 3.1	27.1 / 102.3	23.8 / 90.4	20.7 / 78.3
PSC-85-25	86.7 / 328	24 / 61	57.2 / 145.3	1.25 / 3.1	29.5 / 111.5	26.0 / 98.5	22.5 / 85.3
PSC-119-35	119.7 / 453	24 / 61	75.4 / 191.5	1.25 / 3.1	40.7 / 154	35.9 / 135.9	31.1 / 117.8

Maximum Operating Pressure = 125 PSI, PSC - 80-23 has a maximum operations pressure of 100 PSI.
 Maximum Internal Water Temperature: 120°F (49°C). Maximum Ambient Air Temperature: 120°F (49°C)
 Distance from base to center line of connection is 2-1/4" (5.7 cm)*. Allow 12" (30.5 cm) for service clearance.
 *1-3/4" (4.4 cm) for 16" diameter tanks

Certified to ANSI/NSF 61, Drinking Water System Components

PRO-SOURCE® Composite Fibrewound Tanks

APPLICATIONS

Use wherever pressurized tanks are needed in water systems applications.

SPECIFICATIONS

Inner Liner: One-piece high-density polyethylene

Outer Shell: Fiberglass-wound, oven-cured, and epoxy resin sealed

Exclusive Air Cell: Heavy gauged PEU, meets Water Quality Association standards

Base: Rotatable base with quick connect

Service Connection: Stainless steel, 300 grade

FEATURES

Durable Composite Construction: A rugged one-piece molded inner liner of premium high-density polyethylene.

Miles of continuous overlapping fiberglass strands, sealed with oven-cured epoxy, make the outer shell impervious to rust, dents and ultra-violet rays (no paint to scratch and touch up).

Air Cell: Seamless, durable PEU air cell is full replaceable and constructed of heavy-gauge engineered polymer. Meets Water Quality Association standards.

Tank Base: Rigid molded ABS is the sturdiest composite base on the market. Corrosion- and impact-resistant.

Replaceable Air Cell: Generous and accessible air cell opening facilitates easy removal and re-installation of replacement air cell (with the professional contractor in mind).

Stainless Steel Service Connection: 300 grade, the professional's choice

TANK SIZING RULE:

Size tank for one gallon of drawdown for each gallon per minute at pump capacity.

Example: For a 1 HP, 20 GPM unit pumping 20 gallons per minute on a 30-50 pressure switch setting, the properly sized Pro-Source composite tank is a PSC-80-23, which has a 23.8 gallon drawdown.

PRO-SOURCE® Composite Fibrewound Tanks

OPERATING CYCLE

1. Pro-Source® Composite tank is nearly empty: air cell is fully expanded



2. Water is pumped into tank: air in cell is compressed

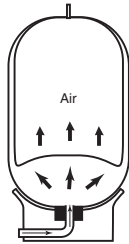

3. Pump-up cycle is complete: air is now compressed to "cut off" setting of pressure switch

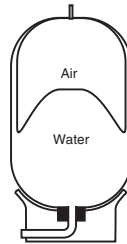

4. Water is drawn from tank: pressure in air cell provides water as needed, until tank is empty and cycle repeats

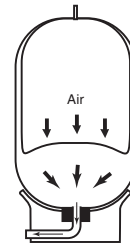

CHART A

TANK SELECTION CHART

Pump GPM	SYSTEM PRESSURE SWITCH SETTING – PSI					
	20-40		30-50		40-60	
	Runtimes					
	1 Minute	2 Minute	1 Minute	2 Minute	1 Minute	2 Minute
5	PSC-20-6	PSC-30-9	PSC-20-6	PSC-40-12	PSC-20-6	PSC-40-12
7.5	PSC-30-9	PSC-48-14	PSC-30-9	PSC-60-20	PSC-30-9	PSC-60-20
12.5	PSC-40-12	PSC-80-23	PSC-48-14	PSC-85-25	PSC-60-20	PSC-119-35
15	PSC-48-14	PSC-119-35	PSC-60-20	PSC-119-35	PSC-60-20	PSC-119-35
20	PSC-60-20	PSC-119-35	PSC-80-23	PSC-80-23 (2)	PSC-80-23	PSC-80-23 (2)
30	PSC-85-25	PSC-85-25 (2)	PSC-119-35	PSC-119-35 (2)	PSC-119-35	PSC-119-35 (2)
50	PSC-80-23 (2)	PSC-119-35 (3)	PSC-85-25 (2)	PSC-119-35 (3)	PSC-119-35 (2)	PSC-119-35 (3)

NOTE: Drawdown will be affected by operating temperature of the system, accuracy of the pressure switch and gauge, the actual precharge pressure, and rate of fill.

CHART B

DRAWDOWN VOLUME MULTIPLIER* (APPROXIMATE)

Pump Off Pressure PSI	PUMP START PRESSURE – PSI							
	10	20	30	40	50	60	70	80
20	0.26							
30	0.41	0.22						
40		0.37	0.18					
50		0.46	0.31	0.15				
60			0.40	0.27	0.13			
70			0.47	0.35	0.24	0.12		
80				0.42	0.32	0.21	0.11	
90				0.48	0.38	0.29	0.19	0.10
100					0.44	0.35	0.26	0.17

*Utilize this chart if proper selection cannot be made using tank selection chart. Drawdown based on Boyle's Law.

Procedure:

1. Identify drawdown multiplier relating to specific application.

2. Insert multiplier (X) into the following formula:

$$\frac{\text{Pump GPM} \times \text{Min Runtime}}{\text{Multiplier (X)}} = \text{Minimum Tank Capacity Required}$$

3. Refer to "Ordering Information" Table – Max. Capacity Gals.

PRO-SOURCE® Composite Fibrewound Tanks

Contact & Sideport Contact

FCT Series
Contact Tanks



SP Series
Sideport Contact Tanks



NSF/ANSI 61
Drinking Water

Built Tough...for Quality

Professional grade composite construction means longer lasting tanks that will not rust, corrode, dent or scratch.

Built Tough...for Durability

Each tank is wrapped with more than three miles of overlapping, continuous fiberglass strands, sealed with high-grade epoxy resin, then oven-cured.

**Built Tough...
for Easy Installation**

Composite construction is lightweight... as little as half the weight of steel tanks. Installation is faster, easier and can be handled by one person.

APPLICATIONS

Residential Water Systems
Industrial, Commercial and Agricultural

SPECIFICATIONS

Inner Liner: One-piece high-density polyethylene

Outer Shell: Fiberglass-wound and epoxy resin sealed

Upper and Lower Flanges: Reinforced polypropylene

Base: One-piece ABS

Service Connections: Reinforced polypropylene

FEATURES

Durable Composite

Construction: A rugged one-piece molded inner liner of premium high-density polyethylene. Miles of continuous overlapping fiberglass strands, sealed with oven-cured epoxy, make the outer shell impervious to rust, dents and ultra-violet rays (no paint to scratch and touch up).

Tank Base: Rigid ABS is the sturdiest composite base on the market. Corrosion- and impact-resistant. Base rotates 360° for ease-of-service hook-up.

Composite Service Connection: Threaded for ease of installation.

ORDERING INFORMATION

FCT SERIES CONTACT TANKS

Catalog Number	Maximum Capacity Gal./Liter	Maximum Operating Pressure PSI/kPa/Bar	Diameter Inch/cm	Overall Height Inch/cm	Height Inlet/Outlet to Floor Inch/cm	Top System Connection	Bottom System Connection	Assembly Weight Lbs./kg
FCT-40	40/151	75/500/5.0	16/41	57.25/145	1.5/3.8	1-1/4" Socket	1-1/4" Socket	28/12.7
FCT-80	80/303	75/500/5.0	21/53	62.75/159	2/5.1	1-1/4" Socket	1-1/4" Socket	43/19.5
FCT-120	120/454	75/500/5.0	24/61	73.25/186	2/5.1	1-1/4" Socket	1-1/4" Socket	63/28.6

Maximum external operating temperature 120°F (49°C).
Maximum internal operating temperature 100°F (38°C).
Minimum operating temperature 40°F (4°C).

Certified to ANSI/NSF 61, Drinking Water System Components.
In order to provide the best products possible, specifications are subject to change.

PRO-SOURCE® Composite Fibrewound Tanks

Contact & Sideport Contact

ORDERING INFORMATION

SP SERIES SIDEPORT CONTACT TANKS

Catalog Number	Maximum Capacity Gal./Liter	Drawdown 30-50 Setting Gallons/Liters	Diameter Inch/cm	Overall Height Inch/cm	Height Inlet/Outlet to Floor Inch/cm	Height Sideport to Floor Inch/cm	Unit Ship Weight Lbs./kg
SP-7	30/114	7/26	16/41	43.75/111	1.5/3.8	14/35.6	26/11.8
SP-9	40/151	9/34	16/41	56.5/144	1.5/3.8	15.5/39.4	35/15.9
SP-9SQ	47/178	9/34	21/53	41.25/105	2/5.1	16.9/42.9	48/21.8
SP-18	80/303	18/67	21/53	62/157	2/5.1	18.3/46.5	67/30.5
SP-26	120/454	26/98	24/61	72.5/184	2/5.1	20.2/51.3	97/44.1
SP-35	205/776	35/132	36/91	73/185	7/17.8	31.5/80.0	290/131.8
SP-50	264/999	50/189	36/91	82/208	7/17.8	31.5/80.0	300/136.4

Maximum Operating Pressure = 100 PSI

1-1/4" System connections sidewall. Customer-supplied air control valve. Bottom, dual port 1-1/4" PVC.



U238-5
Air Volume Controls
(Jet pump type)



E238-2
Air Volume Control
(Submersible type)

PRO-SOURCE® PLUS Premium Steel Tanks

Heavy Gauge Steel



Stainless Steel Service Connection – “The Professional’s Choice”
Metal Air Valve Assembly – “Field-Serviceable”
125 PSI Maximum Operating Pressure – Four Sizes: PSP50, PSP62, PSP85 and PSP119

APPLICATIONS

Residential Water Systems
Industrial, Commercial and Agricultural

SPECIFICATIONS

- Shell:** Heavy-gauge steel
- Base:** High-impact composite, ABS
- Finish:** Electrostatically applied, baked-on polyester paint
- Water Cell:** One-piece seamless PVC, made from FDA listed material
- Flange:** 304SS
- Service Connection:** NPT threads, integral to flange
- Air Valve:** Nickel-plated brass, threaded for ease of service

In order to provide the best products possible, specifications are subject to change.

ORDERING INFORMATION

Catalog Number	Maximum Capacity Gal./Liter	Diameter* Inch/cm	Height* Inch/cm	Precharge PSI/kPa	Connection Size Female	Drawdown In Gallons/Liters			Weight Lbs./kg	Maximum Operating PSI
						20-40	30-50	40-60		
VERTICAL MODELS										
PSP19S-T02	19/72	20/51	21/53.3	40/276	1" NPT	6.9/26.1	5.8/21.9	5.0/18.9	49/22.2	100
PSP19T-T02	19/72	16/40.6	27.5/70	40/276	1" NPT	6.9/26.1	5.8/21.9	5.0/18.9	44/20.0	100
PSP32-T03	32/121	16/40.6	43/109	40/276	1" NPT	11.6/43.9	9.8/37.1	8.5/32.2	60/27.2	100
PSP35-T05	35/133	20/51	33/84	40/276	1" NPT	12.7/48.1	10.7/40.5	9.3/35.2	70/31.8	100
PSP50-T50	50/189	24/61	32.5/83	40/276	1-1/4" NPT	18.3/69.3	15.5/58.7	13.4/50.7	88/39.9	125
PSP62-T51	62/235	24/61	39.5/100	40/276	1-1/4" NPT	21.4/81.0	18.3/69.3	16.0/60.6	116/52.6	125
PSP85-T52	85/322	24/61	51/130	40/276	1-1/4" NPT	30/113.6	26/98.4	22.0/83.3	128/58.1	125
PSP119-TR50	119/450	24/61	68/173	40/276	1-1/4" NPT	41.3/156.3	35.4/134.0	31.0/117.3	140/63.5	125

*Subject to change without notice.
 Maximum Liquid Temperature: 120°F (49°C)
 Maximum External (Ambient) Temperature: 125°F (52°C)

PRO-SOURCE® PLUS Premium Steel Tanks

Heavy-Gauge Steel

FEATURES

Service Connection: 304 stainless steel.

Air Valve: Nickel-plated brass.

Maximum Operating Pressure:

100 PSI on 16" and 20" tanks;

125 PSI on 24" tanks.

Heavy-Gauge Metal Construction:

Sturdy "welded wrapper and head design."

Built to last.

Polyester Paint Finish: Electrostatically

powder-painted, then oven-baked for a

smooth high-gloss, appliance-quality finish.

Resists corrosion.

Elongated, Seamless Water Cell:

- Controlled 2-dimensional cell expansion.

- Rugged, seamless "water cell"

prevents the most common cause

of pump failure - "waterlogging."

- Water never touches the steel

tank material.

- Translucent bag material facilitates manufacturing quality control inspection.

NEW Stainless Service Connection:

- Corrosion-resistant.

- Stainless steel - the professional's choice.

Integral Standpipe: Promotes complete

flushing of the water entering/exiting

the tank.

Nitrogen-Rich Precharge: Decreases air

permeation three to four times over straight

air precharge.

40 PSI Precharge: Ready for use with

40/60 pressure range systems. Enables

installer to reduce pressure depending on

pressure switch setting.

Sturdy Base: Tested-tough

composite construction.

TANK SIZING RULE:

Size tank for one gallon of drawdown for each gallon per minute at pump capacity.

Example: For a 1 HP, 20 GPM unit pumping 20 gallons per minute on a 30-50 pressure switch setting, the properly sized Pro-Source® PLUS tank is a PSP85-T52 which has a 26 gallon drawdown.

CHART A: TANK SELECTION CHART

Pump GPM	SYSTEM PRESSURE SWITCH SETTING - PSI					
	20-40		30-50		40-60	
	Runtimes					
	1 Minute	2 Minute	1 Minute	2 Minute	1 Minute	2 Minute
5	PSP19T	PSP32	PSP19T	PSP35	PSP19T	PSP50
7.5	PSP32	PSP50	PSP32	PSP50	PSP32	PSP62
10	PSP32	PSP62	PSP35	PSP85	PSP50	PSP85
12.5	PSP35	PSP85	PSP50	PSP85	PSP50	PSP119
15	PSP50	PSP85	PSP50	PSP119	PSP62	PSP119
20	PSP62	PSP119	PSP85	PSP85 (2)	PSP85	PSP85 (2)
30	PSP85	PSP85 (2)	PSP119	PSP119 (2)	PSP119	PSP119 (2)
50	PSP62 + PSP85	PSP119 (2) + PSP62	PSP85 (2)	PSP119 (3)	PSP119 (2)	PSP119 (4)

Note: Drawdown will be affected by operating temperature of the system, accuracy of the pressure switch and gauge, the actual precharge pressure, and rate of fill. Pumps installed with a Pro-Source® PLUS tank require a relief valve equal to the tank's maximum operating pressure. Relief valve must be capable of relieving entire flow of pump at relief pressure.

CHART B: DRAWDOWN VOLUME MULTIPLIER* (APPROX.)

Pump Off Pressure PSI	PUMP START PRESSURE - PSI							
	10	20	30	40	50	60	70	80
20	0.26							
30	0.41	0.22						
40		0.37	0.18					
50		0.46	0.31	0.15				
60			0.40	0.27	0.13			
70			0.47	0.35	0.24	0.12		
80				0.42	0.32	0.21	0.11	
90				0.48	0.38	0.29	0.19	0.10
100					0.44	0.35	0.26	0.17

*Utilize this chart if proper selection cannot be made using Chart A. Drawdown based on Boyle's Law.

PROCEDURE: 1. Identify drawdown multiplier relating to specific application.
2. Insert multiplier (X) into the following formula:

$$\frac{\text{Pump GPM} \times \text{Min Runtime}}{\text{Multiplier (X)}} = \text{Minimum Tank Capacity Required}$$

EXAMPLE: An example of a 20 GPM pump with a minimum runtime of 1 minute, installed on a 50-70 PSIG system pressure range:

$$\frac{20 \text{ GPM} \times 1 \text{ minute}}{.24 \text{ (factor) from Chart B}} = 83.3 \text{ minimum U.S. gal. tank capacity required}$$

Referring to "Ordering Information" chart, the model PSP85-T52 has the closest U.S. gallon capacity that is greater or equal to the minimum volume requirement of 83.3 U.S. gallons.

PRO-SOURCE® PLUS Premium Steel Tanks

Heavy-Gauge Steel

OPERATING CYCLE

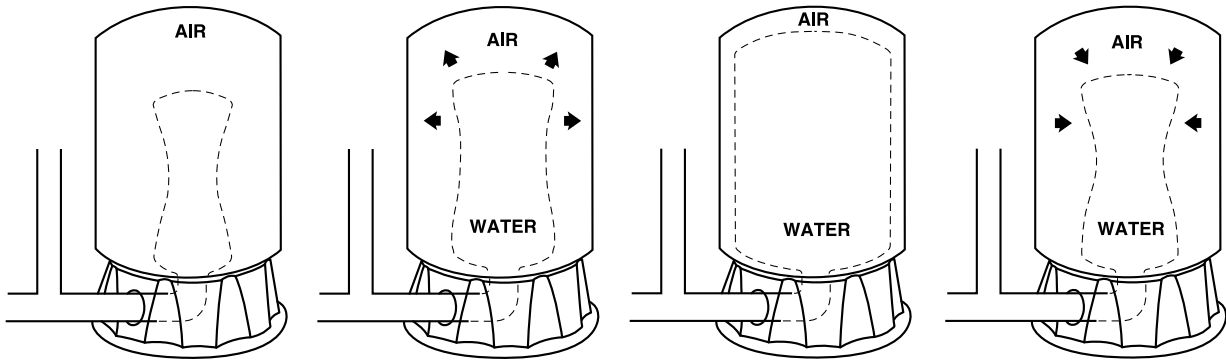

1. Separator is completely empty:
A new cycle is ready to begin.
Simple, positive action produces maximum drawdown on every cycle.

2. Water begins to enter the tank: Air is compressed around the water separator as it fills with water.

3. Pump-up cycle completed:
Air is now compressed to the cut-off setting of pressure switch.

4. Water is being drawn from the tank: Compressed air in the tank forces water out of the separator.

OUTLINE DIMENSIONS

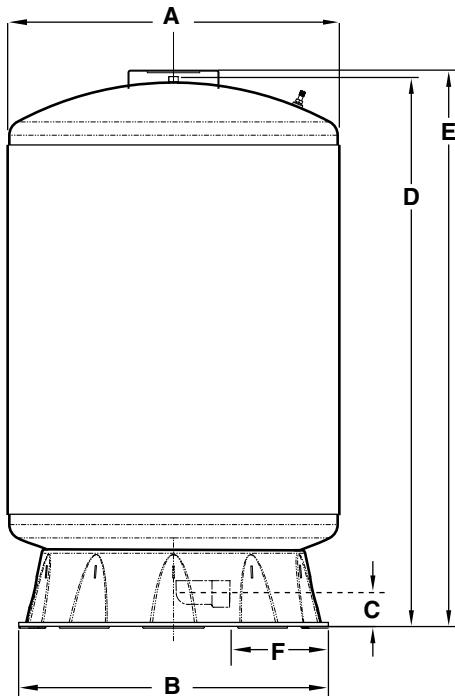

Catalog Number	Discharge NPT	A	B	C	D	E	F
PSP19T-T02	1"	16.1	15.5	2.0	27.8	-	3.9
PSP19S-T02	1"	20.1	15.5	2.0	21.5	-	2.3
PSP32-T02	1"	16.1	15.5	2.0	43.0	-	2.3
PSP35-T05	1"	20.1	15.5	2.0	33.0	-	2.3
PSP50-T50	1-1/4"	24.1	22.7	2.5	33.2	-	5.5
PSP62-T51	1-1/4"	24.1	22.7	2.5	40.1	-	5.5
PSP85-T52	1-1/4"	24.1	22.7	2.5	51.5	-	5.5
PSP119-TR50	1-1/4"	24.1	22.7	2.5	68.6	-	5.5

Dimensions (in inches) are for estimating purposes only.

PRO-SOURCE® Steel Tanks



APPLICATIONS

Use wherever pressurized tanks are needed in water systems applications.

SPECIFICATIONS

Shell: Heavy-gauge steel

Base: High-impact composite, ABS

Finish: Electrostatically applied, baked-on polyester paint

Water Cell: One-piece seamless PVC, made from FDA listed material

Flange: Reinforced polypropylene

Service Connection: Reinforced polypropylene integral to flange

Air Valve: Rubber stem/brass body Schrader valve assembly

UV Valve Cover: High-density polyethylene

ORDERING INFORMATION

Catalog Number	Maximum Capacity Gal/Liter	Diameter* Inch/cm	Height Inch/cm	Length Inch/cm	Precharge PSI/kPa	Connection Size Female	Drawdown in Gallons/Liter			Weight lbs/kg
							20-40	30-50	40-60	
VERTICAL MODELS										
PS6-S02	6.0/22.7	12/30.5	16.1/40.9	-	40/276	3/4" NPT	2.2/8.3	1.8/6.8	1.6/6.0	18/8.2
PS19S-T02	19/72	20/40.6	21/53.3	-	40/276	1" NPT	6.9/26.1	5.8/21.9	5.0/18.9	45/20.4
PS19T-T02	19/72	16/40.6	27.5/70	-	40/276	1" NPT	6.9/26.1	5.8/21.9	5.0/18.9	40/18.1
PS32-T03	32/122	20/51	43/109	-	40/276	1" NPT	11.6/43.9	9.8/37.1	8.5/32.2	56/25.4
PS35-T05	35/133	16/40.6	33/84	-	40/276	1" NPT	12.7/48.1	10.7/40.5	9.3/35.2	66/29.9
PS50-T50	50/189	20/51	32.5/83	-	40/276	1-1/4" NPT	18.3/69.3	15.5/58.7	13.4/50.7	84/38.1
PS62-T51	62/235	24/61	39.5/100	-	40/276	1-1/4" NPT	21.4/81.0	18.3/69.3	16.0/60.6	112/50.8
PS85-T52	85/322	24/61	51/130	-	40/276	1-1/4" NPT	30/113.6	26/98.4	22/83.3	124/56.2
PS119-TR50	119/450	24/61	68/173	-	40/276	1-1/4" NPT	41.3/156.3	35.4/134.0	31.0/117.3	140/63.5
IN-LINE VERTICAL MODELS										
PS2-S01	2.0/7.6	8.4/21.3	12.6/32.0	-	20/137.8	3/4" NPTM	0.7/2.65	0.6/2.2	NA	12.6/5.7
PS5-S02	5.0/18.9	10.6/26.9	16.2/41.1	-	30/206.8	3/4" NPTM	2.2/8.3	1.8/6.8	1.8/6.8	16.2/7.3
HORIZONTAL MODELS										
PS6H-S05	6.0/22.7	12/30.5	13.8/35.0	16/40.6	40/276	3/4" NPT	2.2/8.3	1.8/6.8	1.6/6.0	22/10
PS19H-S00	19/72	16/40.6	17.5/44.5	28/71.1	40/276	1" NPT	6.9/26.1	5.8/21.9	5.0/18.9	40/18

*Subject to change without notice.

Maximum Operating Pressure = 100 PSI

Maximum Liquid Temperature: 120°F (49°C) Maximum External (Ambient) Temperature: 125°F (52°C)

PRO-SOURCE® Steel Tanks

FEATURES

Heavy-Gauge Metal Construction:

Sturdy “welded wrapper and head design.”
Built to last.

Polyester Paint Finish: Electrostatically powder-painted, then oven-baked for a smooth high-gloss, appliance-quality finish. Resists corrosion.

Elongated, Seamless Water Cell:

Controlled 2-dimensional cell expansion.

Rugged, seamless “water cell” prevents the most common cause of pump failure – “waterlogging.”

Water never touches the steel tank material.

Translucent bag material facilitates manufacturing quality control inspection.

Composite Sealing Flange:

- Corrosion-resistant.
- Integral O-ring groove better traps the water cell’s sealing ring.
- Reinforcing ribs strengthen and maintain a flat smooth sealing surface.

Integral Standpipe: Keeps the water cell standing erect, promoting complete flushing of the water entering/exiting the tank.

Nitrogen-Rich Precharge: Decreases air permeation three to four times over straight air precharge.

40 PSI Precharge: Ready for use with 40/60 pressure range systems. Enables installer to reduce pressure depending on pressure switch setting.

Sturdy Base: Tested-tough composite construction.

TANK SIZING RULE:

Size tank for one gallon of drawdown for each gallon per minute at pump capacity.

Example: For a 1 HP, 20 GPM unit pumping 20 gallons per minute on a 30-50 pressure switch setting, the properly sized Pro-Source® tank is a PS85-T52 which has a 26 gallon drawdown.

CHART A: TANK SELECTION CHART

Pump GPM	SYSTEM PRESSURE SWITCH SETTING – PSI					
	20-40		30-50		40-60	
	Runtimes					
	1 Minute	2 Minute	1 Minute	2 Minute	1 Minute	2 Minute
5	PS19T	PS32	PS19T	PS35	PS19T	PS50
7.5	PS32	PS50	PS32	PS50	PS32	PS62
10	PS32	PS62	PS35	PS85	PS50	PS85
12.5	PS35	PS85	PS50	PS85	PS50	PS119
15	PS50	PS85	PS50	PS119	PS62	PS119
20	PS62	PS119	PS85	PS85 (2)	PS85	PS85 (2)
30	PS85	PS85 (2)	PS119	PS119 + PS85	PS119	PS119 (2)
30	-	-	PS119	PS119 + PS85	PS119	PS119 (2)
50	PS62 + PS85	PS85 (3)	PS85 (2)	PS119 (3)	PS85 + PS119	PS119 (3) + PS50

Note: Drawdown will be affected by operating temperature of the system, accuracy of the pressure switch and gauge, the actual precharge pressure, and rate of fill. Pumps installed with a Pro-Source® tank require a 100 PSI relief valve. Relief valve must be capable of relieving entire flow of pump at relief pressure.

CHART B: DRAWDOWN VOLUME MULTIPLIER* (APPROX.)

Pump Off Pressure PSI	PUMP START PRESSURE – PSI							
	10	20	30	40	50	60	70	80
20	0.26							
30	0.41	0.22						
40		0.37	0.18					
50		0.46	0.31	0.15				
60			0.40	0.27	0.13			
70			0.47	0.35	0.24	0.12		
80				0.42	0.32	0.21	0.11	
90				0.48	0.38	0.29	0.19	0.10
100					0.44	0.35	0.26	0.17

*Utilize this chart if proper selection cannot be made using Chart A. Drawdown based on Boyle’s Law.

PROCEDURE: 1. Identify drawdown multiplier relating to specific application.
2. Insert multiplier (X) into the following formula:

$$\frac{\text{Pump GPM} \times \text{Min Runtime}}{\text{Multiplier (X)}} = \text{Minimum Tank Capacity Required}$$

EXAMPLE: An example of a 20 GPM pump with a minimum runtime of 1 minute, installed on a 50-70 PSIG system pressure range:

$$\frac{20 \text{ GPM} \times 1 \text{ minute}}{.24 \text{ (factor) from Chart B}} = 83.3 \text{ minimum U.S. gal. tank capacity required}$$

Referring to “Ordering Information” chart, the model PS85-T52 has the closest U.S. gallon capacity that is greater or equal to the minimum volume requirement of 83.3 U.S. gallons.

PRO-SOURCE® Steel Tanks

OPERATING CYCLE

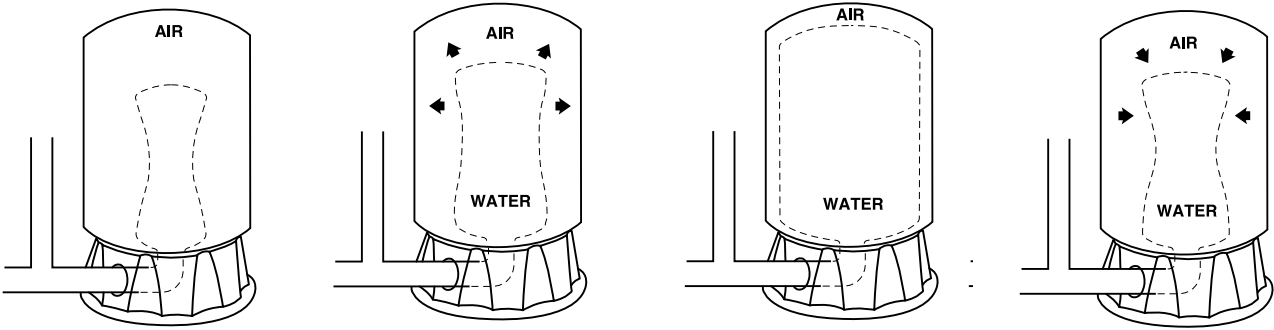

- 1. Separator is completely empty:** A new cycle is ready to begin. Simple, positive action produces maximum drawdown on every cycle.
- 2. Water begins to enter the tank:** Air is compressed around the water separator as it fills with water.
- 3. Pump-up cycle completed:** Air is now compressed to the cut-off setting of pressure switch.
- 4. Water is being drawn from the tank:** Compressed air in the tank forces water out of the separator.

ACCESSORIES

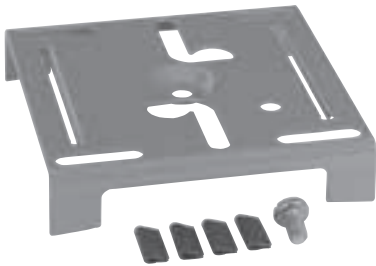

PKG 198
Universal Jet Pump
to Tank Bracket



PKG 111,
PKG 112 or
PKG 207
Jet Pump-to-Tank
Mounting Pkg.

ORDERING INFORMATION

PKG 198	Jet Pump Mounting Bracket
PKG 111	Pump-to-Tank Fitting Package for composite jet pumps
PKG 112	Pump-to-Tank Fitting Package for cast iron series jet pumps with composite fittings
PKG 207	Pump-to-Tank Fitting Package for cast iron series jet pumps with galvanized fittings

MULTIPLE TANK INSTALLATIONS

Pro-Source® tanks can be connected together to increase the supply of usable water (drawdown). Two tanks of the same size will double the supply and three tanks will triple the supply. See Figures No. 1 and 2 for the typical installations of this kind.

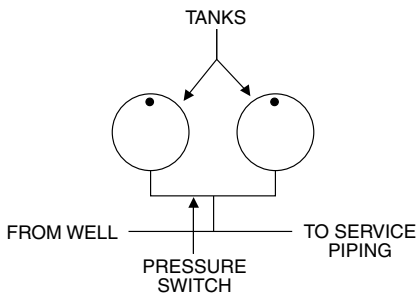

Figure 1

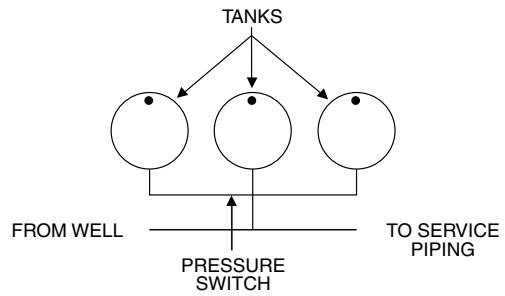
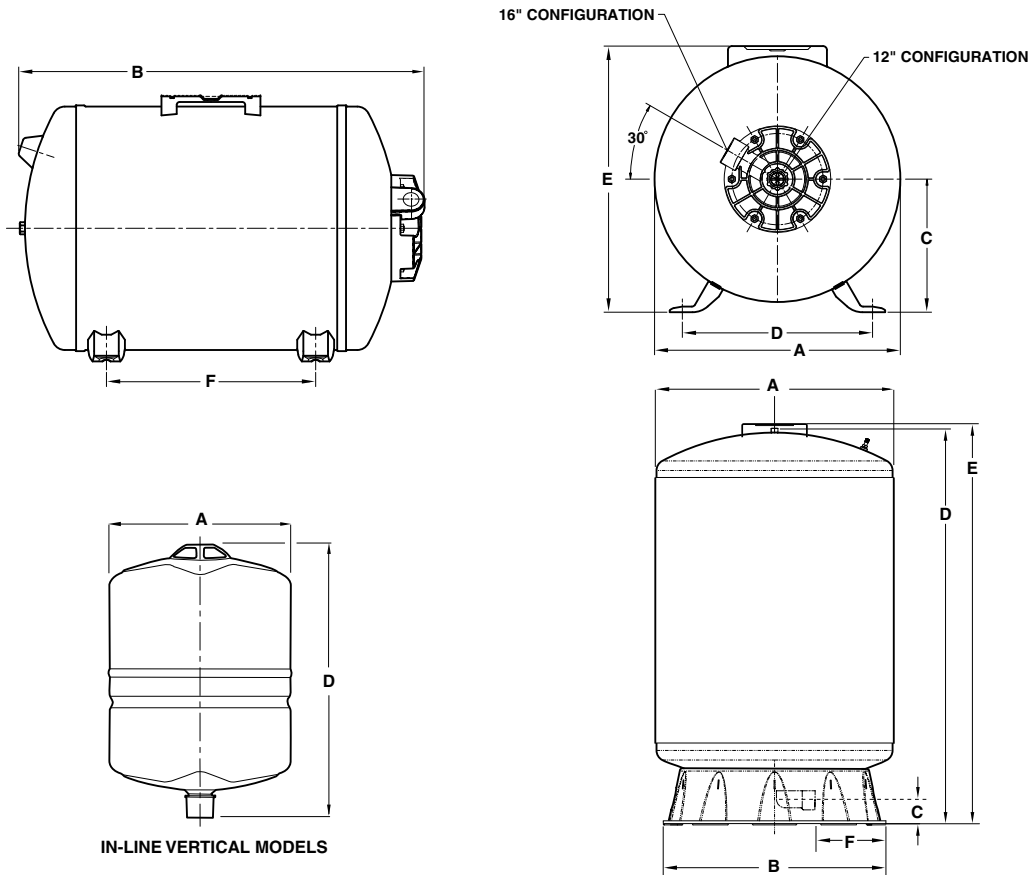

Figure 2

PRO-SOURCE® Steel Tanks

OUTLINE DIMENSIONS



IN-LINE VERTICAL MODELS

Catalog Number	Discharge NPT	A	B	C	D	E	F
VERTICAL MODELS							
PS6-S02	3/4"	12.0	-	-	16.1	-	-
PS19T-T02	1"	16.1	15.5	2.0	27.8	-	3.9
PS32-T03	1"	16.1	15.5	2.0	43.0	-	2.3
PS19S-T02	1"	20.1	15.5	2.0	-	21.5	2.3
PS35-T05	1"	20.1	15.5	2.0	33.0	-	2.3
PS50-T50	1-1/4"	24.1	22.7	2.5	33.2	-	5.5
PS62-T51	1-1/4"	24.1	22.7	2.5	40.1	-	5.5
PS85-T52	1-1/4"	24.1	22.7	2.5	51.5	-	5.5
PS119-TR50	1-1/4"	24.1	22.7	2.5	68.6	-	5.5
IN-LINE VERTICAL MODELS							
PS2-S01	3/4"	18.4	-	-	12.6	-	-
PS5-S02	3/4"	10.6	-	-	16.2	-	-
HORIZONTAL MODELS							
PS6H	3/4"	12.1	16.9	6.9	10.0	13.3	6.1
PS19H	1"	16.2	26.6	8.7	12.5	17.5	13.8

Dimensions (in inches) are for estimating purposes only.

PRO-SOURCE® Steel Tanks

SEQUENCE OF OPERATION

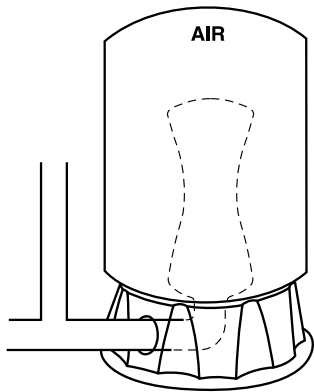

Water cell is completely empty:
A new cycle is ready to begin.
Simple, positive action produces
maximum drawdown on every cycle.

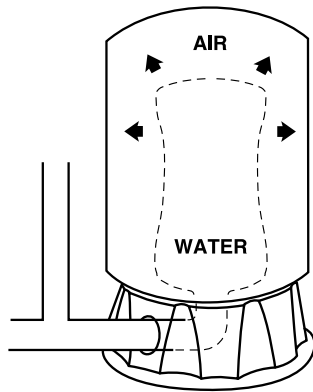

Water begins to enter the tank:
Air is compressed around the water
cell as it fills with water.

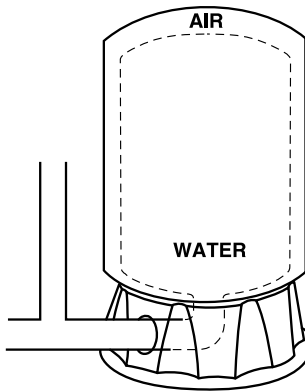

Pump-up cycle completed:
Air is now compressed to the cut-off
setting of pressure switch.

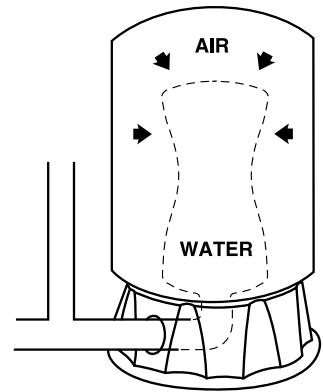

**Water is being drawn from the
tank:** Compressed air in the tank
forces water out of the water cell.

PRO-SOURCE® Steel Epoxy-Lined Air-Over-Water Tanks



The Pro-Source® Epoxy-Lined Tank is an excellent corrosion-resistant tank available in a variety of sizes for use in water systems applications, as a retention tank or holding tank. This tank utilizes an electrostatic paint process, resulting in superior rust protection.

APPLICATIONS

For use as a standard water tank, retention tank or holding tank.

SPECIFICATIONS

- Shell:** Heavy-gauge steel
- Skirt:** Heavy-gauge steel
- Interior Coating:** Epoxy
- Fittings:** Machined steel
- Finish:** Baked-on polyester paint

FEATURES

Quality Construction: The precision press fit head and wrapper minimize the possibility of large gaps between components. This manufacturing process reduces the possibility of corrosion and seam leaks.

Heavy-Gauge Steel: Sturdy construction is emphasized, with heavier gauge steel than most tanks. This minimizes the possibility of dents from mishandling, and rust-through.

Uniform Epoxy Coating: The insides of the tanks are electrostatically powder-coated and then are oven-baked to ensure proper adhesion and consistent coverage. This paint process offers superior corrosion resistance over traditional wet paints.

Appliance-Like Exterior Finish: A polyester paint is also electrostatically adhered to the outer surface and then baked on for a high-gloss appearance.

Flush Mount Fittings: Designed to solve one of the toughest corrosion problems, these fittings eliminate flanges and sharp angles that make paint adherence difficult.

Standard Top Mount Fitting: Facilitates use as a retention tank, or for hard-to-fit areas. This fitting can also be used for an optional jet mount package.

Sturdy Base: Bases for horizontal models are constructed of heavy-gauge steel, with slots for ventilation to avoid condensation problems.

ORDERING INFORMATION

Catalog Number	Capacity U.S. Gal.	Style	Tank Diameter	Tank Height	Tank Length	Approx. Weight Lbs.	Maximum Operating Pressure (PSI)
AW30H	30	Horizontal	16"	17-1/2"	36-1/2"	55	75
AW42	42	Vertical	20"	36-5/8"	N/A	67	75
AW42T	42	Vertical	16"	53-1/2"	N/A	65	75
AW85	85	Vertical	24"	51"	N/A	94	75
AW120	120	Vertical	24"	68"	N/A	120	75

PRO-SOURCE® Steel Epoxy-Lined Air-Over-Water Tanks

VERTICAL OUTLINE DIMENSIONS

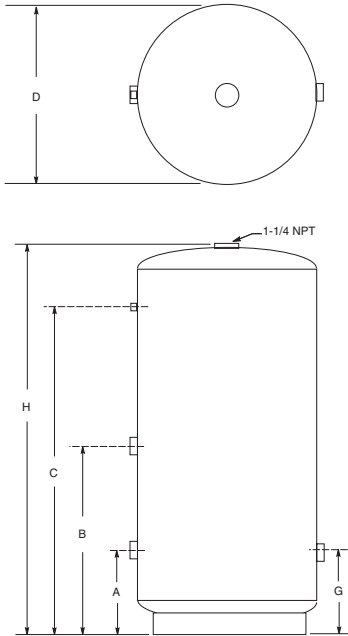

Dimensions (in inches) are for estimating purposes only.

HORIZONTAL OUTLINE DIMENSIONS

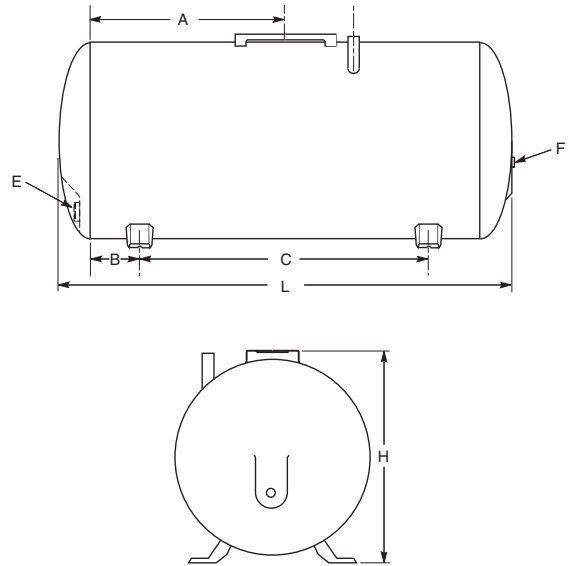

Dimensions (in inches) are for estimating purposes only.

DIMENSIONAL DATA

VERTICAL EPOXY-LINED TANKS

Catalog Number	Gallons	Dimensions in Inches									
		D Dia.	H Ht.	A Dist.	A Size	B Dist.	B Size	C Dist.	C Size	G Dist.	G Size
AW42	42	20	36-5/8	8-1/2	1-1/4	19-1/2	1-1/4	27-3/4	1/4	8-1/2	1-1/4
AW42T	42	16	53-1/2	8	1-1/4	28	1-1/4	45	1/4	8	1-1/4
AW85	85	24	51	12	1-1/4	26-1/8	1-1/4	40-7/8	1/4	9-1/2	1-1/4
AW120	120	24	68	12	1-1/4	35	1-1/4	58-1/8	1/4	9-1/2	1-1/4

HORIZONTAL EPOXY-LINED TANKS

Catalog Number	Gallons	Dimensions in Inches						Outlet Size	
		Dia.	Length	Ht.	A	B	C	E	F
AW30H	30	16	36-1/2	17-1/2	13-3/4	4-3/4	22	3/4	1/4

Horizontal tanks include pump mounting bracket as standard.

Note: All pumps installed with a Pro-Source® tank require a 75 PSI relief valve. Relief valve must be capable of relieving entire pump flow at relief pressure.

TANK PERFORMANCE

Catalog Number	Capacity U.S. Gal.	Drawdown in Gallons		
		20-40	30-50	40-60
AW30H	30	5.2	4.4	3.9
AW42	42	6.7	5.8	5.0
AW42T	42	6.9	5.9	5.2
AW85	85	14.3	12.3	10.7
AW120	120	19.9	17.1	14.9



U238-5
Air Volume Controls
(Jet pump type)



E238-2
Air Volume Control
(Submersible type)

PRO-Storm™ DSS Series Multi-Stage



The Pro-Storm™ multi-stage series of sprinkler pumps delivers high-performance without priming problems and delays.

The Pro-Storm multi-stage series is designed for minimal electrical consumption and quiet operation from the professional-grade motor. The new Pro-Storm multi-stage series offers first-in-class priming capabilities of up to 15 foot lifts!

APPLICATIONS

- Residential and commercial turf irrigation
- Residential water systems
- Shower and washing systems
- Water transfer
- Heating and air conditioning systems
- Water features and fountains

SPECIFICATIONS

Motor Bracket and Integral Pump Base:

Close-grained cast iron, 1-1/2" NPT inlet connection, stable heavy-duty design for rigid pipe and solid base mountings

Discharge: Close-grained cast iron, 1-1/4" NPT discharge connection, with easy-access drain port for end of season draining and winterization

Impellers and Diffusers: Noryl® precision-molded extra-smooth ports to maximize efficiency and performance

Outer Shell: Polished 304 stainless steel

Shaft: 303 stainless steel

Priming Valve: Special brass priming valve for trouble-free operation during the initial pump priming

Mechanical Seal: High-pressure seal, carbon-ceramic seal faces, Buna-N elastomers

Heavy-Duty Motor: 2 HP, single-phase, 3450 RPM, 230-volt, high-service factor, capacitor-start/capacitor-run, open drip-proof motor, rated for continuous-duty operation. 230/460 TEFC available

Maximum Inlet Pressure: 20 PSI

Maximum Discharge Pressure: 130 PSI

Maximum Operating Temperature: 120°F (49°C)

Maximum Suction Lift: 15 feet

Number of Stages: 3 or 4

ORDERING INFORMATION

Catalog Number	Stages	HP	Pipe Tapping Sizes		Motor Voltage	Approx. Wt. Lbs.
			Suction	Discharge		
DSS4HG	4	2	1-1/2" NPT	1-1/4" NPT	230 1ø	95
DSS4HG3T	4	2	1-1/2" NPT	1-1/4" NPT	230/460 TEFC	95
DSS3HG	3	2	1-1/2" NPT	1-1/4" NPT	230 1ø	95
DSS3HG3T	3	2	1-1/2" NPT	1-1/4" NPT	230/460 TEFC	95

Noryl® is a registered trademark of General Electric Co.
All other brand or product names are trademarks or registered trademarks of Pentair Ltd.

PRO-Storm™ DSS Series Multi-Stage

PUMP PERFORMANCE

Nominal RPM: **3450**
 Based on Fresh Water@ **68 deg. F.**
 Maximum Working Pressure: **175 PSI**

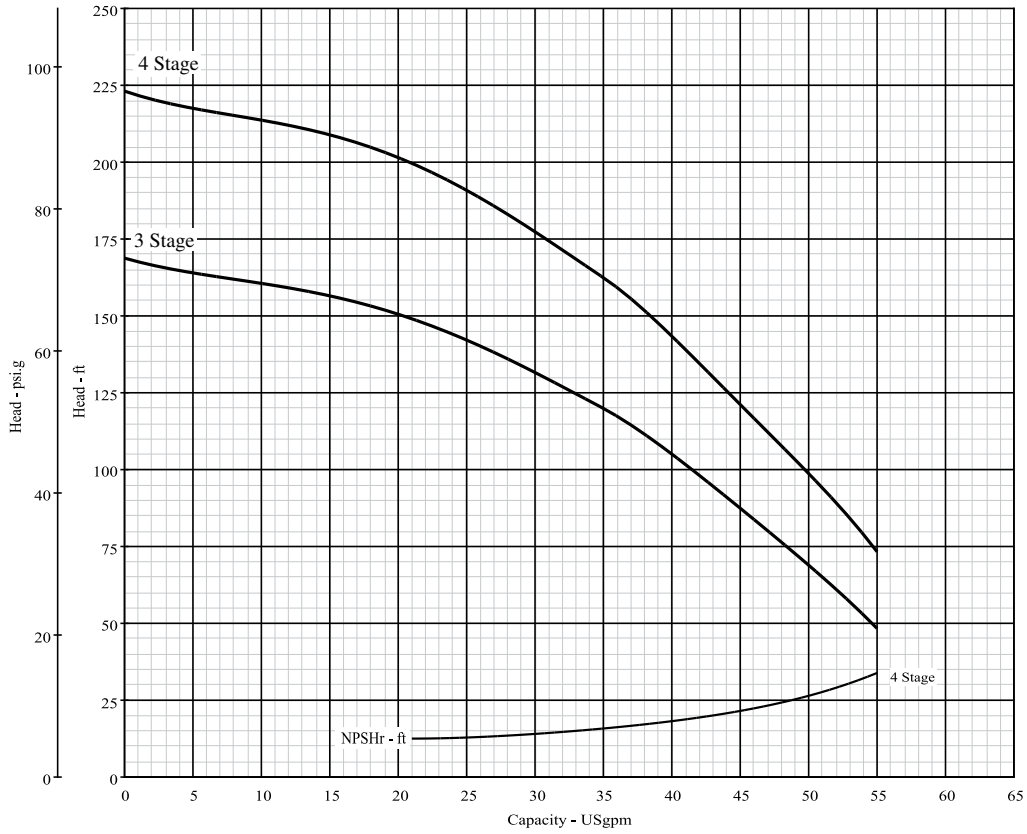

OUTLINE DIMENSIONS

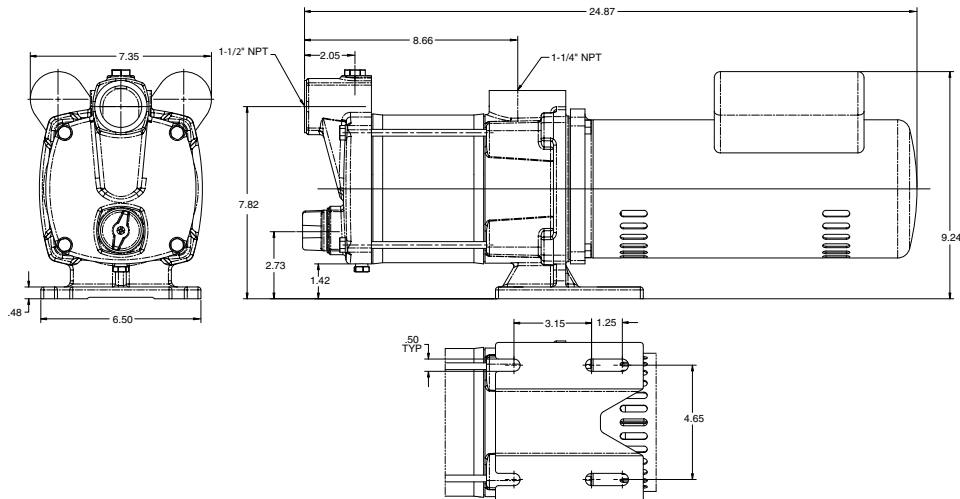

Dimensions (in inches) are for estimating purposes only.

PRO-Storm™ DS3 Series Self-Priming Centrifugal

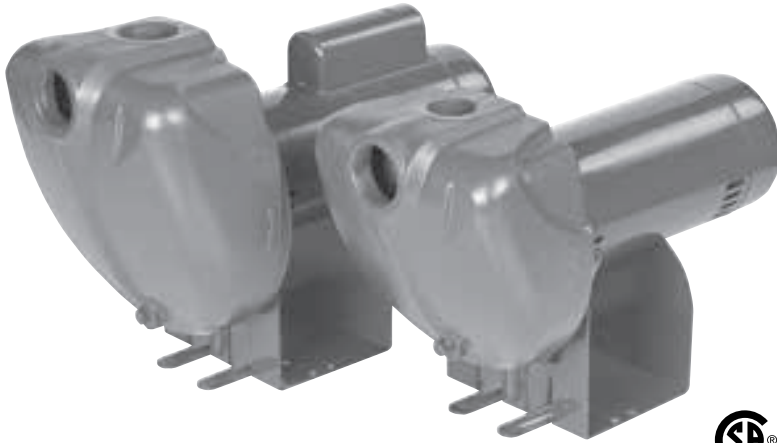

The Pro-Storm™ Series* of cast iron sprinklers offers superior unmatched performance, available in 1 HP through 2-1/2 HP models.

The Pro-Storm models offer “single-body-fill” priming to 25-foot lifts, in less than 5 minutes!

The Pro-Storm models exceed the strict safety requirements of Underwriters Laboratories UL778, and CSA. Required by many state and local codes.

The Pro-Storm models are completely interchangeable with the original

Sta-Rite® DS2 Series models, saving costly plumbing “change-out” dollars and installation headaches!

*Single- and three-phase available

APPLICATIONS

Residential irrigation pump...can be safely operated by timer or other automatic device

Contractors...for dewatering excavation, water transfer and supply

Agriculture...seed bed and plot irrigation, stock watering

Industrial...sump drainage, marine pumping, liquid transfer and supply operations

SPECIFICATIONS

Body and Seal Plate: Close-grained cast iron

Impeller: Noryl®

Diffuser: Reinforced polypropylene

Shaft: One-piece threaded 300 grade stainless steel

Base: Steel, 10 gauge

Motor: 2-compartment

FEATURES

Rugged Construction: Close-grained cast iron body, specially treated for corrosion resistance.

Noryl Impeller: Precision-molded for perfect balance...ultra-smooth for highest performance and efficiency.

Precision-Molded Diffuser: Pump primes faster, handles more air, with multi-port, precision-molded, reinforced polypropylene diffuser.

High Head Models: Deliver up to 145' of head with capacities to 95 GPM.

Easy Serviceability: Normal wearing parts are easily accessible for service and replacement, without disturbing piping or mounting.

Motor Windings: Superior insulation materials protect against excessive moisture and contaminants...ensures prolonged motor life.

Balanced Rotor: Diecast under high pressures for uniform performance and greater efficiency, dynamically balanced.

Drain Port: Provided for easy winterizing.

ORDERING INFORMATION

Catalog Number	HP	Voltage	Phase	High Head		Approx. Wt. Lbs.
				Pipe Tapping Sizes		
				Suction	Discharge	
DS3HE	1	115/230	1	2"	1-1/2"	52
DS3HE3	1	208-230/460	3	2"	1-1/2"	52
DS3HF	1-1/2	115/230	1	2"	1-1/2"	58
DS3HF3	1-1/2	208-230/460	3	2"	1-1/2"	58
DS3HG	2	115/230	1	2"	2"	83
DS3HG3	2	208-230/460	3	2"	2"	83
DS3HHG	2-1/2	115/230	1	2"	2"	85
DS3HHG3	2-1/2	208-230/460	3	2"	2"	85

NOTE: All single-phase motors shipped from the factory set at 230 volt.

Noryl® is a registered trademark of General Electric Co. All other brands or product names are trademarks or registered trademarks of Pentair Ltd.

PRO-Storm™ DS3 Series Self-Priming Centrifugal

PUMP PERFORMANCE

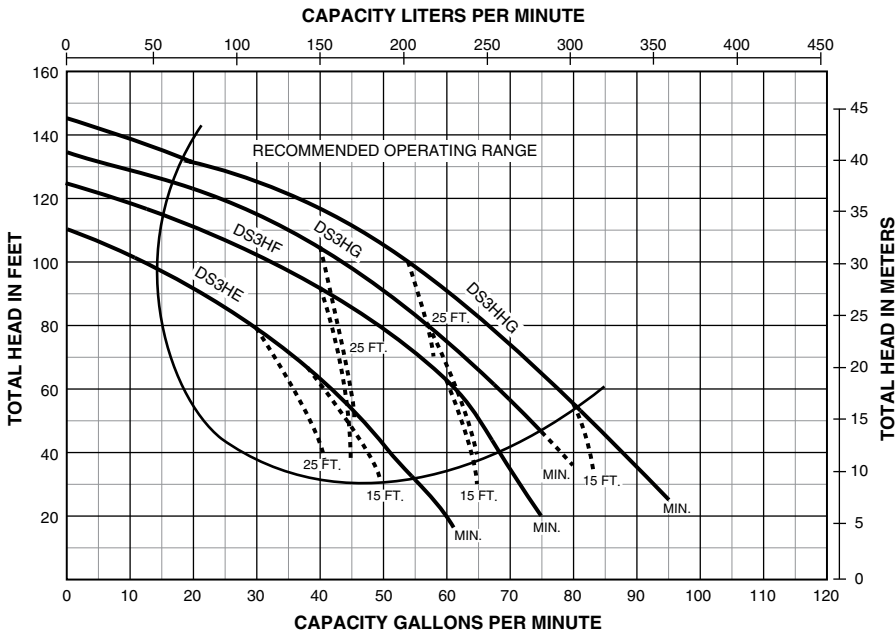

NOTE: Dotted lines indicate performance reduction at high suction lift.

PUMP PERFORMANCE (CAPACITY IN GALLONS PER MINUTE)

Catalog Number	HP	Discharge Pressure		Suction Lift in Feet				
		PSI	Feet Head	5'	10'	15'	20'	25'
DS3HE	1	20	46.2	48	45	40	37	33
		30	69.3	33	30	26	22	16
		40	92.4	15	10	—	—	—
DS3HF	1-1/2	20	46.2	64	62	60	57	54
		30	69.3	53	50	46	42	37
		40	92.4	35	30	25	19	—
DS3HG	2	20	46.2	72	70	67	65	62
		30	69.3	60	58	54	51	47
		40	92.4	45	42	37	30	27
		50	115.5	23	16	—	—	—
DS3HHG	2-1/2	20	46.2	83	80	77	74	71
		30	69.3	70	67	63	60	55
		40	92.4	56	52	48	40	35
		50	115.5	36	28	20	—	—

Tested and rated in accordance with Water Systems Council Standards.

NOTE: Pumps installed with a Pro-Source® tank require a 100 PSI relief valve. Pumps installed with a conventional tank require a 75 PSI relief valve. Relief valve must be capable of relieving entire flow of pump at relief pressure.

PRO-Storm™ DS3 Series Self-Priming Centrifugal

OUTLINE DIMENSIONS

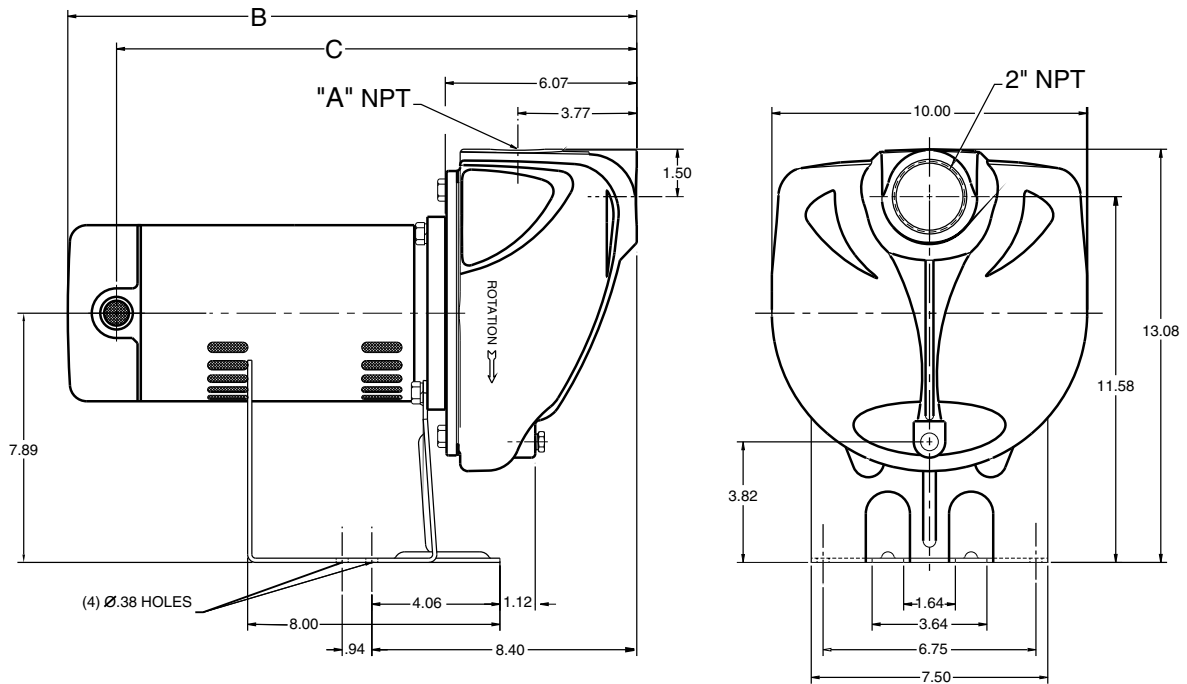

Catalog Number	A NPT	B	C
DS3HE	1-1/2" NPT	17.04	15.60
DS3HE3	1-1/2" NPT	15.45	14.07
DS3HF	1-1/2" NPT	18.10	16.66
DS3HF3	1-1/2" NPT	15.95	14.48
DS3HG	2" NPT	18.54	17.10
DS3HG3	2" NPT	16.95	15.48
DS3HHG	2" NPT	18.85	17.41
DS3HHG3	2" NPT	17.69	16.23

Dimensions (in inches) are for estimating purposes only.

PD Series Self-Priming Sprinkler Pumps

Corrosion-Resistant



Quick priming PD Series Pumps feature lightweight construction in a self-priming design. These models offer a stronger pump body with reinforcement ribs and also a new 2" suction that is designed for the professional pump contractor.

APPLICATIONS

Lawn and landscape sprinkling; self-priming out of tanks or cisterns.
Light chemical transfer for compatible fluids.

SPECIFICATIONS

Body and Base: Fiberglass-reinforced thermoplastic
Impeller: Engineered polymer
Diffuser: Polypropylene
Shaft: 300 grade stainless steel

FEATURES

Quality Construction: Fiberglass-reinforced thermoplastic provides total corrosion resistance and high resistance to sandy water.
Lightweight Design: Space-age materials make these pumps more portable than conventional cast iron pumps.
Composite Impeller: Highest performance and efficiency from ultra-smooth materials Precision-Molded for perfect balance.
Easily Serviced: Normal wearing parts are easily accessible for service and replacement, without disturbing piping or mounting.
Dustproof Cover: Electrical components protected from dust and insects.
Heavy-Duty Motor: Heavy-duty 1 through 2-1/2 HP motors. Designed for continuous operation. Stainless steel shaft.
Dual Voltage Capability: 1 and 1-1/2 HP motors have dual voltage motors and are shipped at the 230-volt setting. 2 and 2-1/2 HP are 230-volt setting only.

ORDERING INFORMATION

Catalog Number	HP	Pipe Tapping Sizes		Motor Voltage	Approx. Wt. Lbs.
		Suction	Discharge		
PD2HE	1	2"	1-1/2"	115/230	38
PD2HF	1-1/2	2"	1-1/2"	115/230	41
PDHG	2	2"	2"	115/230	52
PDHGG	2-1/2	2"	2"	115/230	54

NOTE: All motors are shipped from the factory set at 230 volt.

PD Series Self-Priming Sprinkler Pumps

Corrosion-Resistant

OUTLINE DIMENSIONS

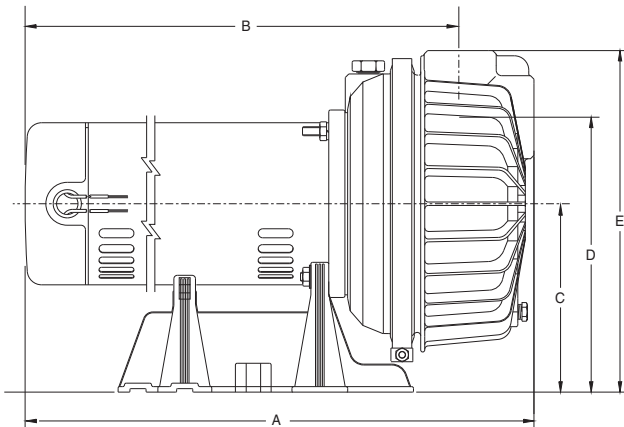

Catalog Number	A	B	C	D	E
PD2HE	17-5/8	15-1/8	6-9/16	9-9/16	11-13/16
PD2HF	18-3/4	16-1/4	6-9/16	9-9/16	11-13/16
PDHG	20	16-3/16	6-9/16	8-7/8	12-3/8
PDHGG	20	16-3/16	6-9/16	8-7/8	12-3/8

Dimensions (in inches) are for estimating purposes only.

PERFORMANCE (CAPACITY IN GALLONS PER MINUTE)

Disch. Press. PSI	PD2HE					PD2HF					PDHG					PDHGG				
	Distance Above Water																			
	5'	10'	15'	20'	25'	5'	10'	15'	20'	25'	5'	10'	15'	20'	25'	5'	10'	15'	20'	25'
10	53	52	50	48	46	67	66	64	61	59	70	69	67	64	62	90	88	86	82	80
20	45	42	39	37	35	59	56	54	50	47	61	59	56	53	50	79	76	72	70	65
30	35	31	27	24	18	48	44	40	37	32	50	48	44	41	37	66	62	57	55	50
40	17	10				31	26	20	10		36	33	25	23	19	50	45	42	37	32
50											16	9				30	23	20		

PUMP PERFORMANCE

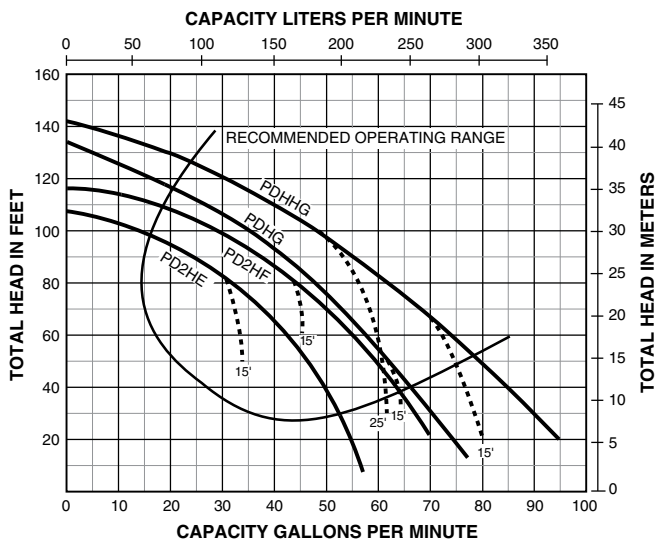

NOTE: Dotted lines indicate performance reduction at high suction lift.

D Series Self-Priming Centrifugal Pumps

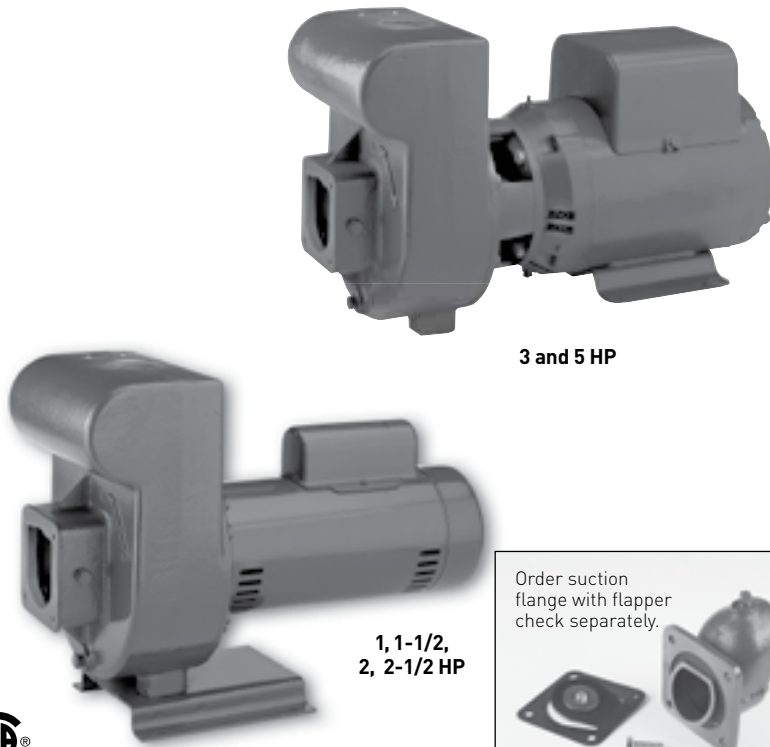

3 and 5 HP

1, 1-1/2,
2, 2-1/2 HP

Order suction flange with flapper check separately.



Some of the fastest priming pumps on the market. Available in high head or medium head series. Features mechanical seals, easy service design, heavy-duty motors, rugged construction. Available in 1 through 5 HP.

Optional 6" and 8" Trap Packages are available.

APPLICATIONS

Lawn Sprinkling...operate from 1 to 30 or more heads. Can be safely operated by timer or other automatic device.

Contractors...for dewatering excavation, jetting, water transfer and supply operations.

Agriculture...seed bed and plot irrigation, stock watering, fire protection.

Industrial...sump drainage, fire protection, marine pumping, liquid transfer and supply operations.

SPECIFICATIONS

Body and Base: Close-grained cast iron

Impeller: Noryl® on 1 through 2-1/2 HP, bronze on 3 and 5 HP

Diffuser: Cast iron

Shaft: 1 through 2-1/2 HP: 416 stainless steel; 3 and 5 HP: Carbon steel inside removable shaft sleeve of stainless steel.

FEATURES

1 through 5 HP: Both high head and medium head models offer heavy-duty motors, easy service design, and air volume control tapping.

Drain Port: Provided for easy winterizing.

Medium Head Models: Deliver up to 115' of head with capacities to 159 GPM.

High Head Models: Deliver up to 138' of head with capacities to 162 GPM.

Easy Serviceability: Normal wearing parts are easily accessible for service and replacement, without disturbing piping or mounting.

Heavy-Duty Motors: Designed for continuous operation. Capacitor start, will not cause electrical interference with TV or other appliances. Nationally known motors have ball bearing, stainless steel shaft. For single- and three-phase operation, 3450 RPM.

Noryl® is a registered trademark of General Electric Co.
All other brand or product names are trademarks or registered trademarks of Pentair Ltd.

D Series Self-Priming Centrifugal Pumps

ORDERING INFORMATION

Catalog Number	HP	Pipe Tapping Sizes		Motor Voltage	Phase	Approx. Wt. Lbs.
		Suction Flanges*	Pump Discharge			
		HIGH HEAD				
DHE	1	PKG 52	1-1/2"	115/230	1	65
DHE3	1	PKG 52	1-1/2"	208-230/460	3	65
DHF	1-1/2	PKG 52	1-1/2"	115/230	1	72
DHF3	1-1/2	PKG 52	1-1/2"	208-230/460	3	72
DHG	2	PKG 53	2"	115/230	1	113
DHG3	2	PKG 53	2"	208-230/460	3	113
DHHG	2-1/2	PKG 53	2"	115/230	1	120
DHHG3	2-1/2	PKG 53	2"	208-230/460	3	120
DHH	3	PKG 53	2"	230	1	144
DHH3	3	PKG 53	2"	208-230/460	3	144
DHJ	5	PKG 72	2"	230	1	184
DHJ3	5	PKG 72	2"	208-230/460	3	184
MEDIUM HEAD						
DMG	2	PKG 52	1-1/2"	115/230	1	86
DMG3	2	PKG 52	1-1/2"	208-230/460	3	86
DMMG	2-1/2	PKG 53	2"	115/230	1	93
DMMG3	2-1/2	PKG 53	2"	208-230/460	3	93
DMH	3	PKG 72	2-1/2"	230	1	137
DMH3	3	PKG 72	2-1/2"	208-230/460	3	137
DMJ	5	PKG 73	3"	230	1	184
DMJ3	5	PKG 73	3"	230/460	3	184

*Suction flanges must be ordered separately. See chart below.

SUCTION FLANGES (Order separately - required for suction tap sizes)

Package 52 -	Package 53 -	Package 72 -	Package 73 -
1-1/2"	2"	2-1/2"	3"



PKG 52
1-1/2"



PKG 53
2" NPT

PKG 72
2-1/2"

PKG 73
3" NPT

6" AND 8" TRAP PACKAGES

Catalog Number	Description	Suction Port Size	Approx. Wt. Lbs.
PKG 51	6" Cast Iron Trap with Basket (For C, CC, and D Series Pumps)	2" NPT	20
PKG 76	Cast Iron Flange for Remote Installation	3" NPT	4
PKG 98	8" Cast Iron Trap with Basket (For C, CC, and D Series Pumps)	3" NPT	40

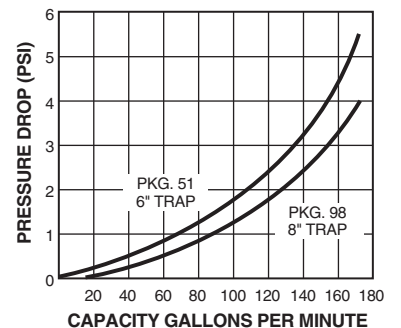

PKG 51
6-INCH TRAP

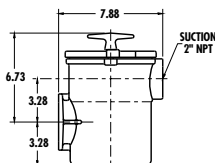

PKG 98
8-INCH TRAP

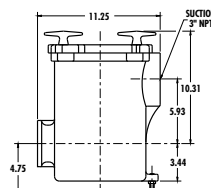

PKG 76

D Series Self-Priming Centrifugal Pumps

PUMP PERFORMANCE: HIGH HEAD

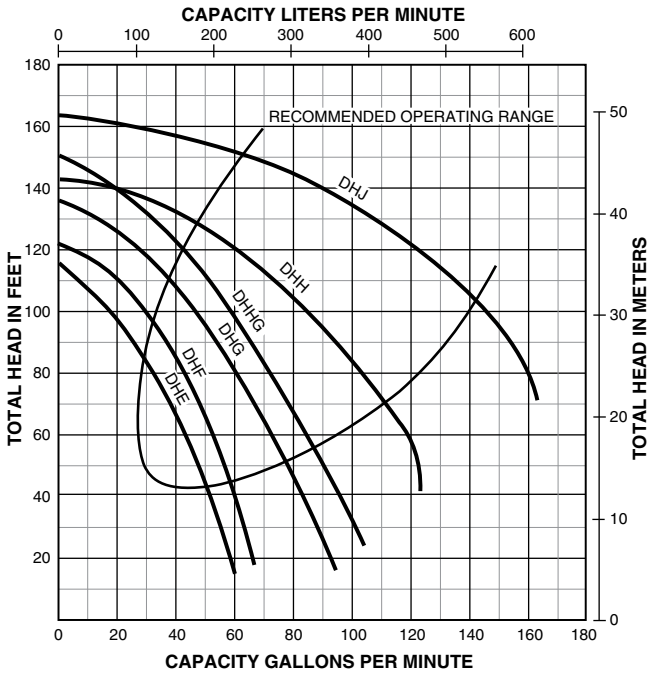

PUMP PERFORMANCE: MEDIUM HEAD

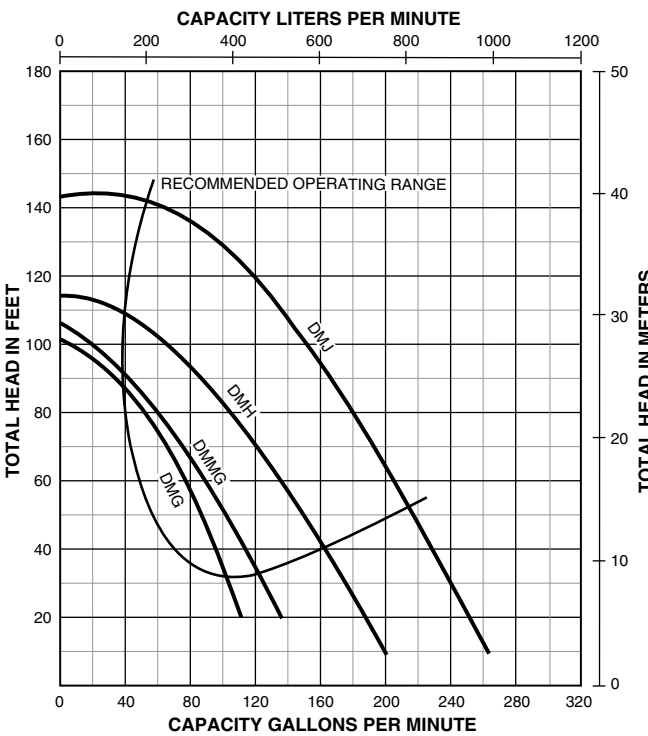

PUMP PERFORMANCE (CAPACITY IN GALLONS PER MINUTE)

HIGH HEAD

Cat. No.	HP	Discharge		Suction Lift in Feet				
		PSI	Feet Head	5'	10'	15'	20'	25'
DHE	1	20	46.2	46	43	41	40	38
		30	69.3	35	32	29	25	21
		40	92.4	19	15	-	-	-
		50	115.5	-	-	-	-	-
		60	138.6	-	-	-	-	-
DHF	1-1/2	20	46.2	55	53	51	49	48
		30	69.3	45	42	39	36	32
		40	92.4	31	27	22	15	-
		50	115.5	-	-	-	-	-
		60	138.6	-	-	-	-	-
DHG	2	20	46.2	77	74	71	68	65
		30	69.3	63	60	56	53	49
		40	92.4	48	44	40	36	30
		50	115.5	30	20	13	-	-
		60	138.6	-	-	-	-	-
DHHG	2-1/2	20	46.2	89	85	82	80	76
		30	69.3	75	72	68	64	60
		40	92.4	60	57	51	49	42
		50	115.5	42	37	31	25	20
		60	138.6	14	-	-	-	-
DHH	3	20	46.2	-	-	-	112	109
		30	69.3	109	103	98	92	89
		40	92.4	90	75	74	69	62
		50	115.5	62	51	42	32	20
		60	138.6	-	-	-	-	-
DHJ	5	20	46.2	-	-	-	-	-
		30	69.3	-	-	-	-	-
		40	92.4	146	141	136	130	122
		50	115.5	122	114	105	99	85
		60	138.6	81	70	50	30	-

MEDIUM HEAD

DMG	2	20	46.2	84	79	74	69	63
		30	69.3	60	53	46	35	20
		40	92.4	22	-	-	-	-
		50	115.5	-	-	-	-	-
DMMG	2-1/2	20	46.2	103	96	90	80	70
		30	69.3	70	60	50	46	30
		40	92.4	30	18	5	-	-
DMH	3	20	46.2	149	140	136	124	119
		30	69.3	116	108	99	85	76
		40	92.4	75	65	51	26	-
DMJ	5	20	46.2	214	209	202	194	182
		30	69.3	185	179	172	165	158
		40	92.4	153	146	139	130	120
		50	115.5	119	107	95	80	50

D Series Self-Priming Centrifugal Pumps

OUTLINE DIMENSIONS

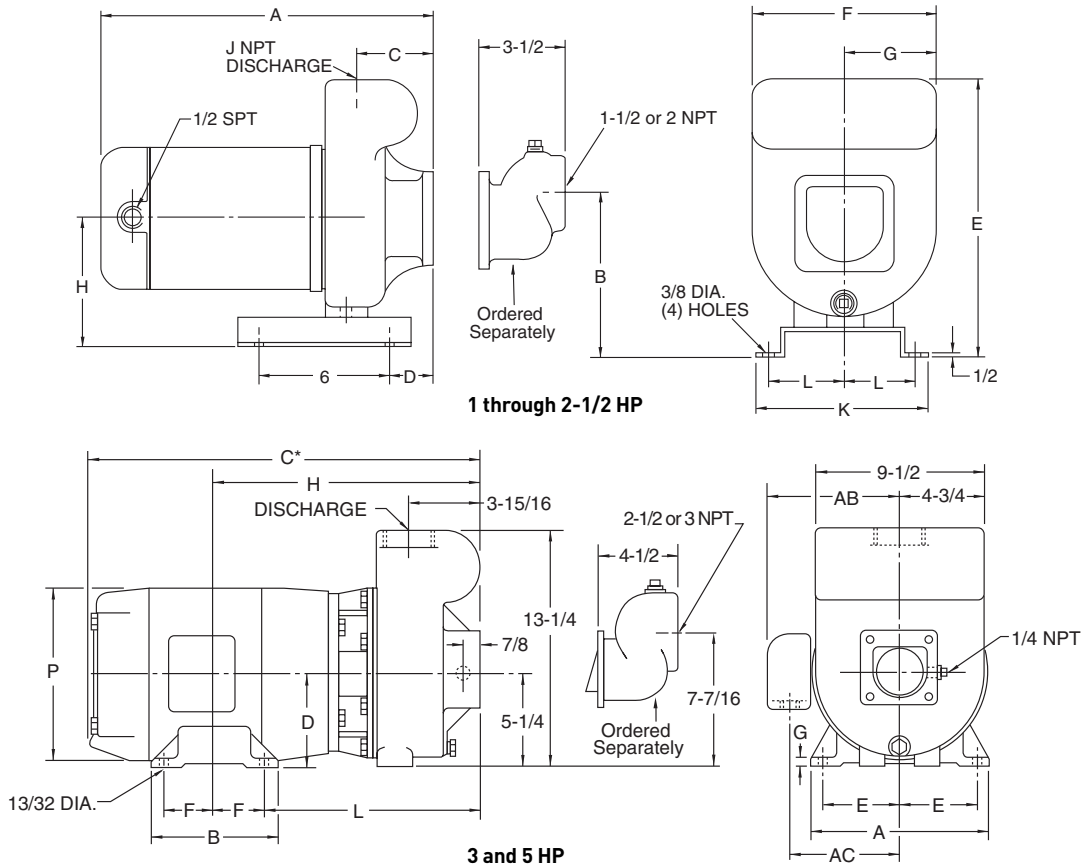

Dimensions (in inches) are for estimating purposes only.

DIMENSIONS IN INCHES: 1 THROUGH 2-1/2 HP

Catalog Number	HP	A	B	C	D	E	F	G	H	J	K	L
DHE	1	14-13/16	7-1/16	3-1/2	4	11-7/8	7-7/8	3-15/16	5-13/16	1-1/2	7-1/2	3-3/8
DHF	1-1/2	15-11/16	7-1/16	3-1/2	4	11-7/8	7-7/8	3-15/16	5-13/16	1-1/2	7-1/2	3-3/8
DHG	2	17-11/16	7-13/16	3-15/16	3-13/16	14-3/8	9-1/2	4-3/4	6-9/16	2	7-1/2	3-3/8
DHHG	2-1/2	18-11/16	7-13/16	3-15/16	3-13/16	14-3/8	9-1/2	4-3/4	6-9/16	2	7-1/2	3-3/8
DMG	2	16-15/16	7-1/16	3-1/2	4	11-7/8	7-7/8	3-15/16	5-13/16	1-1/2	7-1/2	3-3/8
DMMG	2-1/2	17-15/16	7-1/16	3-1/2	4	11-7/8	7-7/8	3-15/16	5-13/16	2	7-1/2	3-3/8

DIMENSIONS IN INCHES: 3 AND 5 HP

Catalog Number	HP	A	B	C*	D	E	F	G	H	L	P	AB	AC
DHH	3	9	6	20-3/4	4-1/2	3-3/4	2-1/4	1/2	15	12-3/4	9-3/4	8-1/8	6-1/2
DHJ	5	9	7	21-3/4	4-1/2	3-3/4	2-3/4	1/2	15-1/2	12-3/4	9-3/4	9	7
DMH	3	9	6	20-3/4	4-1/2	3-3/4	2-1/4	1/2	15	12-3/4	9-3/4	8-1/8	6-1/2
DMJ	5	9	7	21-3/4	4-1/2	3-3/4	2-3/4	1/2	15-1/2	12-3/4	9-3/4	9	7

*Overall length (C) is shown for single-phase motors. Three-phase motors are slightly smaller. Dimensions are for estimating purposes only.

CC Series Straight Centrifugal Pumps

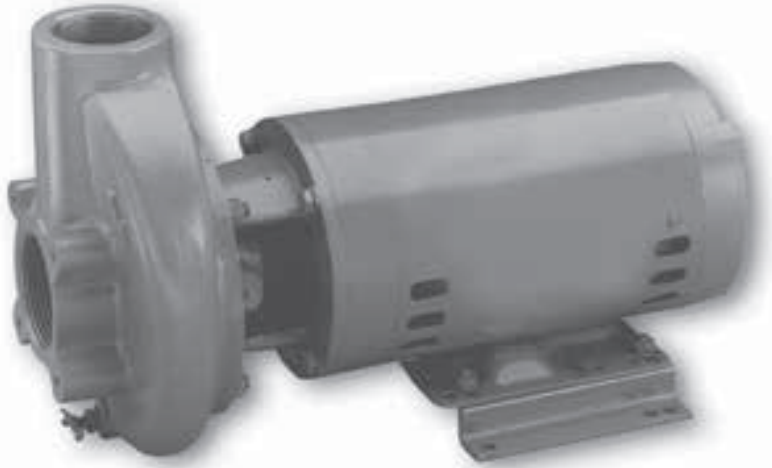

Optional Flange and Trap Packages Available

The CC Series Pumps are compact and lightweight, but rugged. Choose from 3 or 5 HP high head and medium head models. For lower pressures and maximum capacity, medium head models offer heads to 75 feet and capacities to 220 GPM. Where higher pressures are desired, the high head model offers heads to 102 feet and capacities to 260 GPM.

APPLICATIONS

Water Systems

Sprinkling for homes, farms and industry

See page 133 for flange and trap packages.

SPECIFICATIONS

Body: Close-grained cast iron

Base: Heavy-gauge steel

Impeller: Silicon brass (non-lead)

Rugged Motors: 3 to 5 HP, 3450 RPM, open drip-proof, continuous-duty rated. 40°C ambient maximum, NEMA series, JM construction.

Shaft: Carbon steel inside a 300 Series stainless steel sealed removable shaft sleeve.

Bearings: Permanently sealed ball type, pre-lubricated.

Thermal Overload Protection:

Single-phase motors: automatic reset; Three-phase motors: external thermal protection required.

Max. Liquid Temperature: 125°F

Ambient Air Temperature: 104°F

Max. Pressure: 75 PSI

FEATURES

Compact and Lightweight: Can be installed where most other 3 and 5 HP pumps will not fit...requires just 11-3/8" x 18-1/2". Complete pumps weigh only 66 to 94 lbs.

4-Position Discharge: Permits installation with discharge horizontal or vertical, to right or left. Volute features drain port which is functional when discharge is vertical.

Silicon Brass Impeller and

Wear Ring: Silicon brass impeller is precision cast and machined. Dynamically balanced for long seal life and quiet operation. Non-overloading. Contains no lead. Silicon brass wear ring is replaceable.

Easy Service: Back pull-out design: entire motor may be removed for servicing impeller, seal or motor without disturbing plumbing. Centerline discharge for ease of installation.

Shaft Seal: Mechanical, ceramic and carbon seal faces. Stainless steel spring and Buna-N bellows.

ORDERING INFORMATION

HIGH HEAD						
Catalog Number	HP	Pipe Tapping Sizes		Motor Voltage*	Phase	Approx. Wt. Lbs.
		Suction	Discharge			
CCHH	3	2-1/2"	2"	230	1	80
CCHH3	3	2-1/2"	2"	230/460	3	66
CCHJ	5	2-1/2"	2"	230	1	94
CCHJ3	5	2-1/2"	2"	230/460	3	80
MEDIUM HEAD						
CCMH	3	2-1/2"	2"	230	1	80
CCMH3	3	2-1/2"	2"	230/460	3	66

Maximum load amps may vary with motor suppliers.

*200-volt and 575-volt models are available. Consult factory.

CC Series Straight Centrifugal Pumps

OUTLINE DIMENSIONS

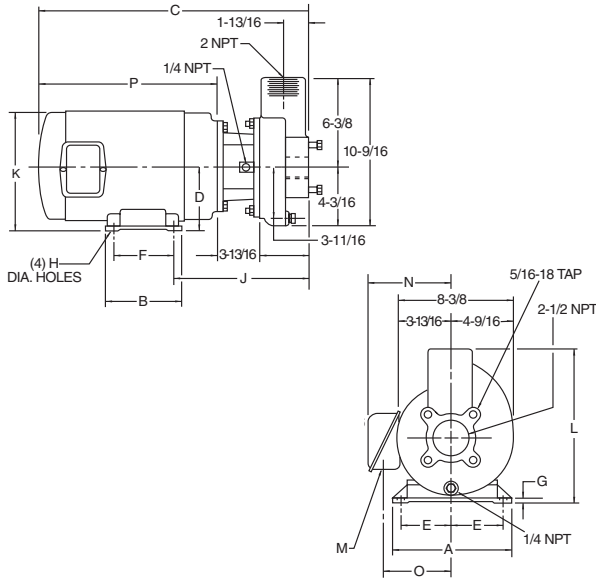

Dimensions (in inches) are for estimating purposes only.

PUMP PERFORMANCE

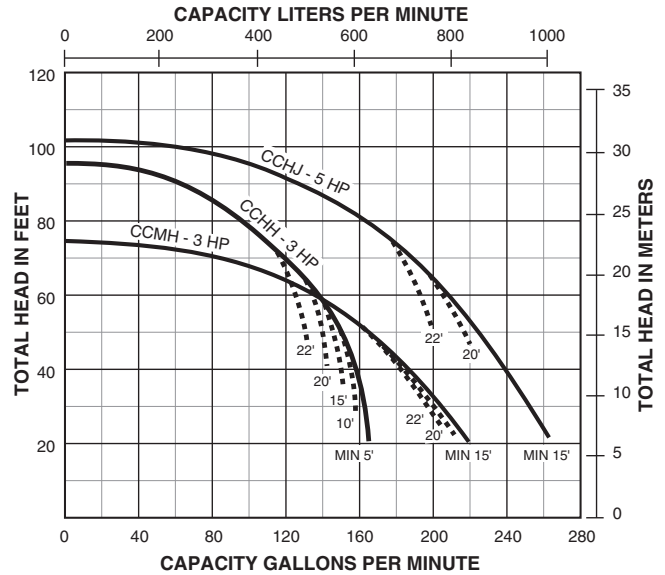

NOTE: Dotted lines indicate performance reduction at high suction lift.

DIMENSIONAL DATA

Catalog Number	A	B	C*	D	E	F	G*	H*	J	K	L	M*	N*	O*	P*
CCHH CCMH	9	6-1/2	21-1/2	4-1/2	3-3/4	4-1/2	7/16	7/16	10-5/16	9-23/32	10-7/8	3/4	8-1/8	6-1/2	14-1/8
CCHH3 CCMH3	7	6	18-13/32	3-1/2	2-3/4	5	9/32	11/32	9-9/32	7-7/32	9-7/8	3/4	6-29/32	5-13/32	11
CCHJ CCHJ3	9	7-1/2	22-1/2	4-1/2	3-3/4	5-1/2	7/16	7/16	10-5/16	9-23/32	10-7/8	3/4	9	6-15/16	15-1/8

*Dimensions may vary with motor supplier.

PUMP PERFORMANCE (CAPACITY IN GALLONS PER MINUTE)

HIGH HEAD

Cat. No.	HP	Discharge Pressure		Dynamic Suction Lift				
		PSI	Feet Head	5'	10'	15'	20'	22'
CCHH	3	20	46.2	148	142	134	125	120
		30	69.3	110	98	85	60	57
		40	92.4	-	-	-	-	-
CCHJ	5	20	46.2	222	214	205	196	190
		30	69.3	180	166	152	125	120
		40	92.4	90	-	-	-	-

MEDIUM HEAD

CCMH	3	20	46.2	165	148	133	112	100
		30	69.3	-	-	-	-	-
		40	92.4	-	-	-	-	-

Tested and rated in accordance with Water Systems Council Standards.

NOTE: Pumps installed with a Pro-Source® tank require a 100 PSI relief valve. Pumps installed with a conventional tank require a 75 PSI relief valve. Relief valve must be capable of relieving entire flow of pump at relief pressure.

DPC Series Self-Priming Centrifugal Pump



The DPC Series self-priming centrifugal pump is a rugged cast iron pump capable of priming up to 20' vertically and will handle solids up to 0.225" diameter. The unit is equipped with a 1/2 HP 115-volt motor and features 1-1/4" suction and discharge.

APPLICATIONS

Effluent and Wastewater Removal
 Sump Drainage
 Dewatering
 Circulation
 Fountains

SPECIFICATIONS

Volute: Cast iron
Impeller: Polycarbonate
Diffuser: Thermoset
Shaft: One-piece threaded stainless steel
Base: Steel 12 gauge
Maximum Liquid Temperature Limits: 130°F (55°C)

FEATURES

Motor: 1/2 HP, 3450 RPM, 115-volt split phase, 60 Hz. Built-in thermal overload protection with automatic reset.
Mechanical Seal: Buna-N elastomers, carbon and ceramic sealing faces, stainless steel metal part.
Heavy-Duty Ball Bearings: Shielded, permanently lubricated bearings, extensively tested to ensure extended life and smooth, quiet operation.
Built-in Convenience: Comes complete with built-in overload protection with automatic reset and a built-in check valve.
Power Cord: 10', 115 volt.

ORDERING INFORMATION

Catalog Number	HP	Volts	Phase/Cycles
DPC	1/2	115	1/60

DPC Series Self-Priming Centrifugal Pump

OUTLINE DIMENSIONS

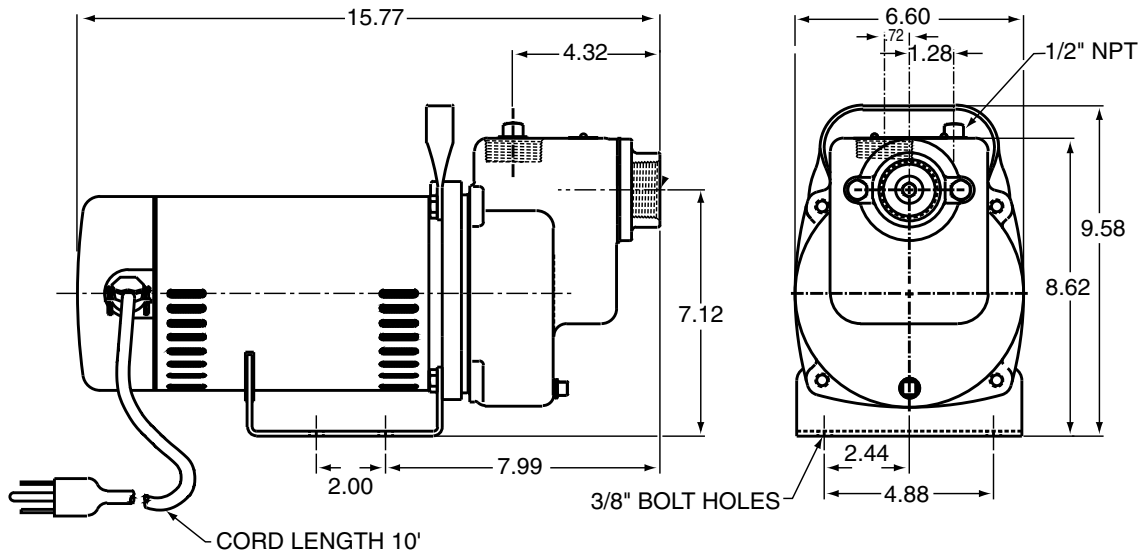

NOTE: 1-1/4" SUCTION AND DISCHARGE
ALL DIMENSIONS ± .06

Dimensions (in inches) are for estimating purposes only.

PUMP PERFORMANCE

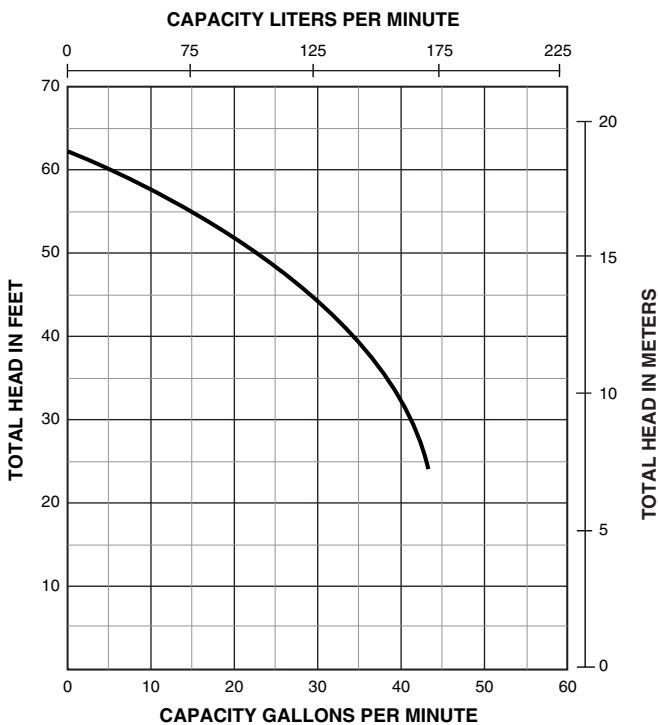

J/JB Series General Purpose Centrifugal Pumps



The J/JB Series Pumps have a heavy-duty cast iron construction and are offered in high and medium head models, with Noryl® or silicon bronze impeller.

APPLICATIONS

Water systems and sprinkling... for homes, farms and industry.

SPECIFICATIONS

Body and Seal Plate: Close-grained cast iron

Base: Steel 12 gauge

Impeller: J Series – Noryl

Impeller: JB Series – Silicon bronze

Shaft: 416 stainless steel

Mechanical Seal: Carbon/ceramic, Buna-N

FEATURES

1/3 through 2-1/2 HP: High head and medium head models, with heavy-duty motors, easy service design and four-position discharge.

Drain Port: Provided for easy winterizing.

Medium Head Models: Deliver up to 110' of head with capacities to 140 GPM.

High Head Models: Deliver up to 140' of head with capacities to 90 GPM.

Easy Serviceability: All models include replaceable wear ring and feature back pull-out design.

J Series with Noryl Impellers: Abrasion-resistant for normal applications with working temperatures to 140°F.

JB Series with Silicon Bronze: JB pumps equipped with shaft seals rated for temperatures to 225°F.

ORDERING INFORMATION

HIGH HEAD

Catalog Number		HP	Pipe Tapping Sizes		Motor Voltage	Phase	Approx. Wt. Lbs.
Noryl® Impeller	Silicon Bronze Impeller		Suct.	Disch.			
JHB	JBHB	1/3	1-1/4"	1"	115/230	1	38
JHC	JBHC	1/2	1-1/4"	1"	115/230	1	39
JHC3	JBHC3		208-230/460	3	39		
JHD	JBHD	3/4	1-1/4"	1"	115/230	1	42
JHD3	JBHD3		208-230/460	3	42		
JHE	JBHE	1	1-1/4"	1"	115/230	1	45
JHE3	JBHE3		208-230/460	3	45		
JHF	JBHF	1-1/2	1-1/4"	1"	115/230	1	49
JHF3	JBHF3		208-230/460	3	49		
JHG	JBHG	2	1-1/2"	1-1/4"	115/230	1	69
JHG3	JBHG3		208-230/460	3	69		
JHHG	JBHHG	2-1/2	2"	1-1/2"	115/230	1	74
JHHG3	JBHHG3		208-230/460	3	74		

ORDERING INFORMATION

MEDIUM HEAD

Catalog Number		HP	Pipe Tapping Sizes		Motor Voltage	Phase	Approx. Wt. Lbs.
Noryl® Impeller	Silicon Bronze Impeller		Suct.	Disch.			
JMB	JBMB	1/3	1-1/4"	1"	115/230	1	38
JMC	JBMC	1/2	1-1/4"	1"	115/230	1	39
JMC3	JBMC3		208-230/460	3	39		
JMD	JBMD	3/4	1-1/4"	1"	115/230	1	42
JMD3	JBMD3		208-230/460	3	42		
JME	JBME	1	1-1/2"	1-1/4"	115/230	1	43
JME3	JBME3		208-230/460	3	43		
JMF	JBMF	1-1/2	1-1/2"	1-1/4"	115/230	1	54
JMF3	JBMF3		208-230/460	3	54		
JMG	JBMG	2	1-1/2"	1-1/4"	115/230	1	66
JMG3	JBMG3		208-230/460	3	66		
-	JBMMG	2-1/2	2"	1-1/2"	115/230	1	74
-	JBMMG3		208-230/460	3	74		

Noryl® is a registered trademark of General Electric Co. All other brand or product names are trademarks or registered trademarks of Pentair Ltd.

J/JB Series General Purpose Centrifugal Pumps

PUMP PERFORMANCE

HIGH HEAD

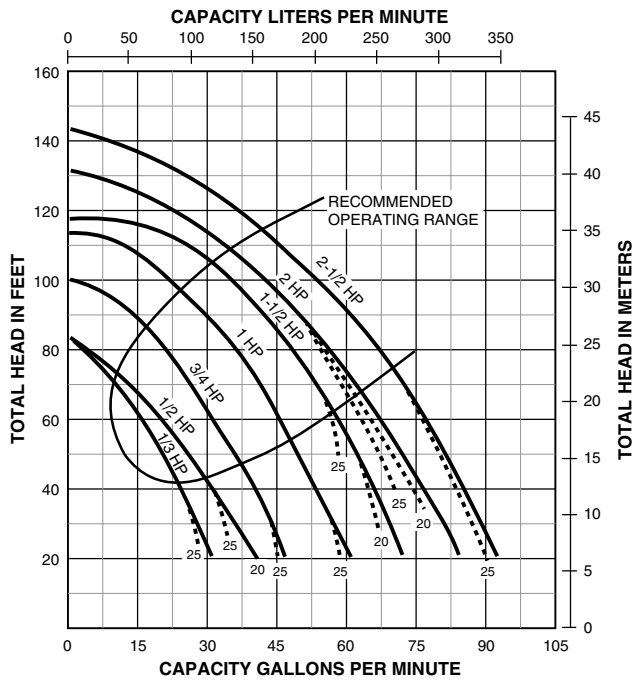

MEDIUM HEAD

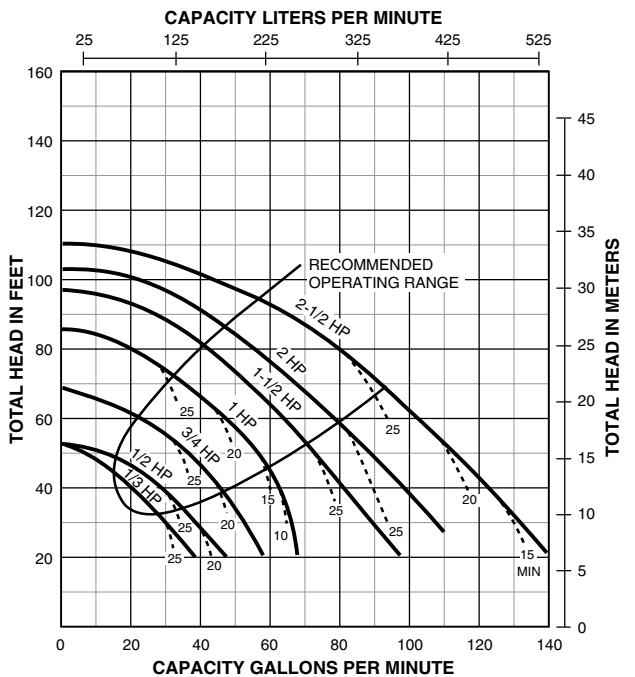

NOTE: Dotted lines indicate performance reduction at high suction lift.

PUMP PERFORMANCE (CAPACITY IN GALLONS PER MINUTE)

HIGH HEAD

HP	Discharge Pressure		Dynamic Suction Lift				
	PSI	Feet Head	5'	10'	15'	20'	25'
1/3	10	23.1	—	26	24	22	20
	20	46.2	20	18	15	11	10
	30	69.3	6	—	—	—	—
1/2	10	23.1	—	34	32	29	26
	20	46.2	25	21	18	15	11
	30	69.3	10	—	—	—	—
3/4	10	23.1	—	—	42	39	37
	20	46.2	35	32	30	28	26
	30	69.3	24	22	19	15	10
1	20	46.2	48	46	45	43	40
	30	69.3	38	35	31	28	25
	40	92.4	23	20	15	—	—
1-1/2	20	46.2	62	60	58	55	52
	30	69.3	50	48	44	40	37
	40	92.4	37	32	29	22	—
2	20	46.2	71	68	66	62	60
	30	69.3	60	57	52	59	45
	40	92.4	45	40	36	31	24
	50	115.5	22	15	—	—	—
	20	46.2	81	79	76	74	71
2-1/2	30	69.3	69	67	63	60	56
	40	92.4	56	51	47	44	38
	50	115.5	33	30	22	15	—

Tested and rated in accordance with Water Systems Council Standards.

NOTE: Pumps installed with a Pro-Source® tank require a 100 PSI relief valve. Pumps with a conventional tank require a 75 PSI relief valve. Relief valve must be capable of relieving entire flow of pump at relief pressure.

J/JB Series General Purpose Centrifugal Pumps

PUMP PERFORMANCE (CAPACITY IN GALLONS PER MINUTE)

MEDIUM HEAD

HP	Discharge Pressure		Dynamic Suction Lift				
	PSI	Feet Head	5'	10'	15'	20'	25'
1/3	10	23.1	32	27	18	—	—
	20	46.2	—	—	—	—	—
1/2	10	23.1	40	37	32	27	17
	20	46.2	—	—	—	—	—
3/4	10	23.1	—	50	46	42	32
	20	46.2	37	29	21	—	—
1	20	46.2	54	51	44	40	33
	30	69.3	33	28	18	—	—
1-1/2	20	46.2	71	69	62	57	51
	30	69.3	52	47	34	30	20
2	20	46.2	88	84	78	70	66
	30	69.3	67	60	50	45	40
	40	92.4	25	13	—	—	—
2-1/2	20	46.2	111	106	101	95	90
	30	69.3	90	83	77	70	60
	40	92.4	46	38	20	—	—

Tested and rated in accordance with Water Systems Council Standards.
 NOTE: Pumps installed with a Pro-Source® tank require a 100 PSI relief valve. Pumps with a conventional tank require a 75 PSI relief valve. Relief valve must be capable of relieving entire flow of pump at relief pressure.

OUTLINE DIMENSIONS

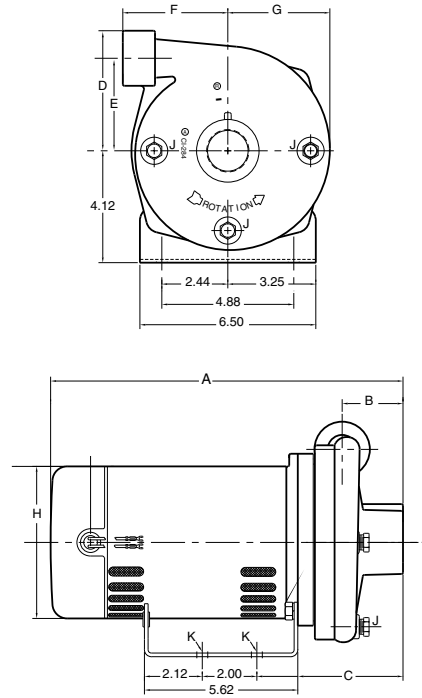

Dimensions (in inches) are for estimating purposes only.

DIMENSIONS (IN INCHES)

HIGH HEAD

HP	NPT Suct.	NPT Disch.	A (1 Phase)	A (3 Phase)	B	C	D	E	F	G	H	NPT J	K
1/3	1-1/4	1	13	13-3/8	2-1/16	5-9/16	4-1/2	3-7/16	3-7/8	3-15/16	5-5/8	1/4	3/8 Dia.
1/2	1-1/4	1	11-21/32	13-3/8	2-1/16	5-9/16	4-1/2	3-7/16	3-7/8	3-15/16	5-5/8	1/4	3/8 Dia.
3/4	1-1/4	1	11-25/32	13-3/8	2-1/16	5-9/16	4-1/2	3-7/16	3-7/8	3-15/16	5-5/8	1/4	3/8 Dia.
1	1-1/4	1	12-25/32	13-7/8	2-1/16	5-9/16	4-1/2	3-7/16	3-7/8	3-15/16	5-5/8	1/4	3/8 Dia.
1-1/2	1-1/4	1	13-39/64	14-3/8	2-1/16	5-9/16	4-1/2	3-7/16	3-7/8	3-15/16	5-5/8	1/4	3/8 Dia.
2	1-1/2	1-1/4	16-3/4	16-15/16	2-13/16	6-5/16	4-27/32	3-13/32	4-5/8	4	6-7/16	1/4	3/8 Dia.
2-1/2	2	1-1/2	17-3/4	17-1/4	2-13/16	6-5/16	4-27/32	3-13/32	4-5/8	4	6-7/16	1/4	3/8 Dia.

MEDIUM HEAD

1/3	1-1/4	1	12-9/16	12-15/16	1-7/16	5-1/8	4-7/16	3-1/4	2-1/4	3-1/4	5-5/8	1/4	3/8 Dia.
1/2	1-1/4	1	11-7/32	12-15/16	1-7/16	5-1/8	4-7/16	3-1/4	2-1/4	3-1/4	5-5/8	1/4	3/8 Dia.
3/4	1-1/4	1	11-31/32	12-15/16	1-7/16	5-1/8	4-7/16	3-1/4	2-1/4	3-1/4	5-5/8	1/4	3/8 Dia.
1	1-1/2	1-1/4	12-11/32	13-7/16	1-7/16	5-1/8	4-7/16	3-1/4	2-1/4	3-1/4	5-5/8	1/4	3/8 Dia.
1-1/2	1-1/2	1-1/4	13-25/32	14-9/16	2	5-3/4	4-13/16	3-1/2	4-1/4	3-15/16	5-5/8	1/4	3/8 Dia.
2	1-1/2	1-1/4	16-3/16	16-3/8	2	5-3/4	4-13/16	3-1/2	4-1/4	3-15/16	6-7/16	1/4	3/8 Dia.
2-1/2	2	1-1/2	17-3/16	16-11/16	2	5-3/4	4-13/16	3-1/2	4-1/4	3-15/16	6-7/16	1/4	3/8 Dia.

HP/HPS Series Signature 2000®

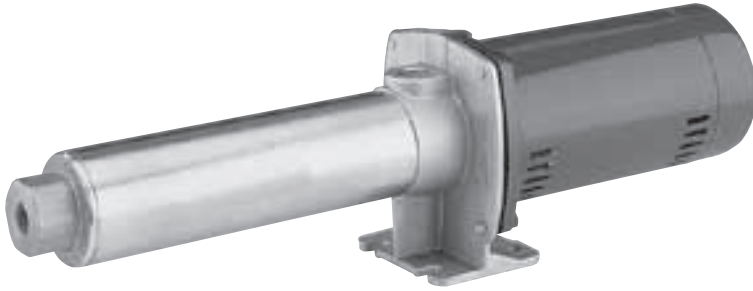

The HP/HPS Booster Pumps are the most durable booster pump available. The proven SignaSeal™ floating impeller design minimizes thrust loads allowing for continuous operation without damage to motor bearings, mechanical seal or pump hydraulic components.

APPLICATIONS

Car wash
 Filtration and reverse osmosis
 Residential, commercial or agricultural pressure washing
 Booster and spray systems
 HVAC
 General purpose pumping

SPECIFICATIONS

Max. Inlet Pressure: 80 PSI
Max. Working Pressure: 315 PSI
Max. Suction Lift: 15 feet
Maximum Limits: Prolonged use with liquids above 140°F is not recommended.
Discharge:
HP Series: cast iron
HPS Series: stainless steel
Motor Adapter and Base:
HP Series: cast iron
HPS Series: stainless steel
Shell: Stainless steel 304 grade
Impeller: Acetal
Diffuser: Polycarbonate
Shaft: Stainless steel 304 grade
O-Rings: Buna-N
Mechanical Seal: Carbon/ceramic, Buna-N

FEATURES

SignaSeal Staging System: The proven SignaSeal staging system utilizes a ceramic wear surface that, when incorporated with Sta-Rite's "true" independent floating impellers, dominates with 1st-in-class performance, superior sand handling and thrust management staging system.

Acetal Impellers: Precision-molded for perfect balance...ultra-smooth for highest performance and efficiency.

Precision-Molded Diffusers: Superior performance with high resistance to corrosion and abrasion.

Mechanical Shaft Seal: Precision lapped and highly polished carbon-ceramic, stainless steel construction. Internal design guarantees continuous water lubrication.

Motor Windings: Superior insulation materials protect against excessive moisture and contaminants...assure prolonged motor life.

Balanced Rotor: Diecast under high pressures for uniform performance and greater efficiency; dynamically balanced.

Heavy-Duty Ball Bearings: Shielded, permanently lubricated bearings, extensively tested to ensure extended life and smooth, quiet operation.

Pump and Motor Shaft: Stainless steel for maximum corrosion resistance; one-piece threaded shaft for positive impeller drive.

Dustproof Cover: All electrical components are protected from dirt, dust and insects by a dustproof canopy; ventilating air cannot contaminate.

TEFC Models available. Contact Customer Service.

HP/HPS Series Signature 2000®

ORDERING INFORMATION

Catalog Number		GPM	HP	Phase	Stages	Pipe Tapping Sizes		Motor Voltage	Shipping Wt. (Lbs.)
Cast Iron	Stainless Steel					Inlet	Outlet		
HP7C	HPS7C	7	1/2	1	9	3/4"	3/4"	115/230	48
HP7C3	HPS7C3		1/2	3	9	3/4"	3/4"	208-230/460	45
HP7D	HPS7D		3/4	1	12	3/4"	3/4"	115/230	48
HP7D3	HPS7D3		3/4	3	12	3/4"	3/4"	208-230/460	45
HP7E	HPS7E		1	1	16	3/4"	3/4"	115/230	51
HP7E3	HPS7E3		1	3	16	3/4"	3/4"	208-230/460	48
HP10C	HPS10C	10	1/2	1	6	3/4"	3/4"	115/230	45
HP10C3	HPS10C3		1/2	3	6	3/4"	3/4"	208-230/460	42
HP10D	HPS10D		3/4	1	8	3/4"	3/4"	115/230	46
HP10D3	HPS10D3		3/4	3	8	3/4"	3/4"	208-230/460	43
HP10E	HPS10E		1	1	10	3/4"	3/4"	115/230	50
HP10E3	HPS10E3		1	3	10	3/4"	3/4"	208-230/460	47
HP10F	HPS10F		1-1/2	1	14	3/4"	3/4"	115/230*	58
HP10F3	HPS10F3		1-1/2	3	14	3/4"	3/4"	208-230/460	53
HP10G	HPS10G		2	1	16	3/4"	3/4"	115/230*	63
HP10G3	HPS10G3		2	3	16	3/4"	3/4"	208-230/460	59
HP20E	HPS20E	20	1	1	7	1"	1"	115/230	49
HP20E3	HPS20E3		1	3	7	1"	1"	208-230/460	46
HP20F	HPS20F		1-1/2	1	9	1"	1"	115/230*	57
HP20F3	HPS20F3		1-1/2	3	9	1"	1"	208-230/460	52
HP20G	HPS20G		2	1	11	1"	1"	115/230*	62
HP20G3	HPS20G3		2	3	11	1"	1"	208-230/460	58
HP20HG	HPS20HG		2-1/2	1	13	1"	1"	115/230*	58
HP20HG3	HPS20HG3		2-1/2	3	13	1"	1"	208-230/460	54
HP20H	HPS20H		3	1	15	1"	1"	208/230	59
HP20H3	HPS20H3		3	3	15	1"	1"	200-230/460	55
HP30E	HPS30E	30	1	1	5	1-1/4"	1-1/4"	115/230	47
HP30E3	HPS30E3		1	3	5	1-1/4"	1-1/4"	208-230/460	44
HP30F	HPS30F		1-1/2	1	6	1-1/4"	1-1/4"	115/230*	54
HP30F3	HPS30F3		1-1/2	3	6	1-1/4"	1-1/4"	208-230/460	49
HP30G	HPS30G		2	1	7	1-1/4"	1-1/4"	115/230*	57
HP30G3	HPS30G3		2	3	7	1-1/4"	1-1/4"	208-230/460	53
HP30HG	HPS30HG		2-1/2	1	9	1"	1"	115/230*	69
HP30HG3	HPS30HG3		2-1/2	3	9	1"	1"	208-230/460	54
HP30H	HPS30H		3	1	11	1-1/4"	1-1/4"	208/230	59
HP30H3	HPS30H3		3	3	11	1-1/4"	1-1/4"	200-230/460	55

Note: ODP motor is standard; for TEFC motors, contact Customer Service.

*HPS models 230V only.

ORDERING INFORMATION (ACCESSORIES)

Pkg. No.	Description	Approx. Wt. Lbs.
SUCTION		
83	Suction hose – 3/4" 150 PSI hose, 6 ft. section with two (2) female hose fittings	3
85	Two (2) garden hose/NPT adapters – 3/4" NPT male to 3/4" garden hose male	3
150 PSI RATED* DISCHARGE		
84	Discharge hose – 3/4" 150 PSI hose, 25 ft. section with male and female garden hose fittings	10
86	High-pressure pistol-grip nozzle with three (3) nozzles (No. 56, 50 and 49)	2

*To select proper discharge accessories for your pump, add incoming pressure to pump output pressure, to determine total discharge pressure.

Example: Incoming pressure 20 PSI + pump output pressure (HP7C at 0 GPM, 300') 87 PSI = Total 150 PSI at discharge = 150 PSI rated discharge accessories

HP/HPS Series Signature 2000®

PUMP PERFORMANCE: 7 GPM

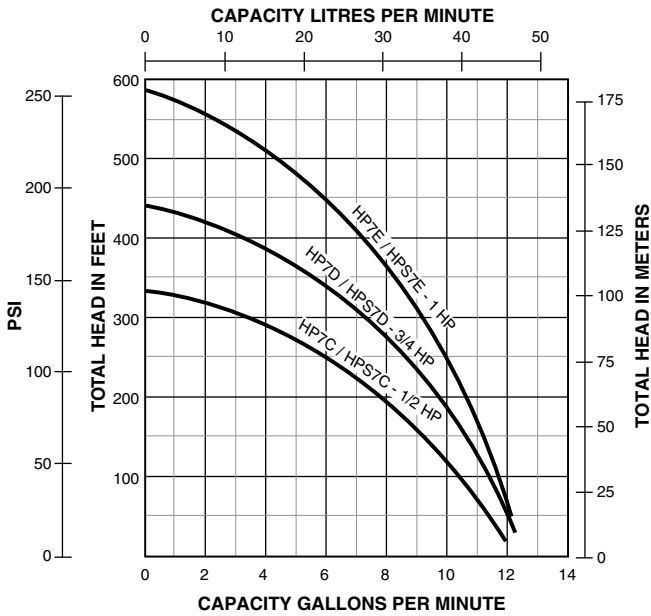

PUMP PERFORMANCE: 10 GPM

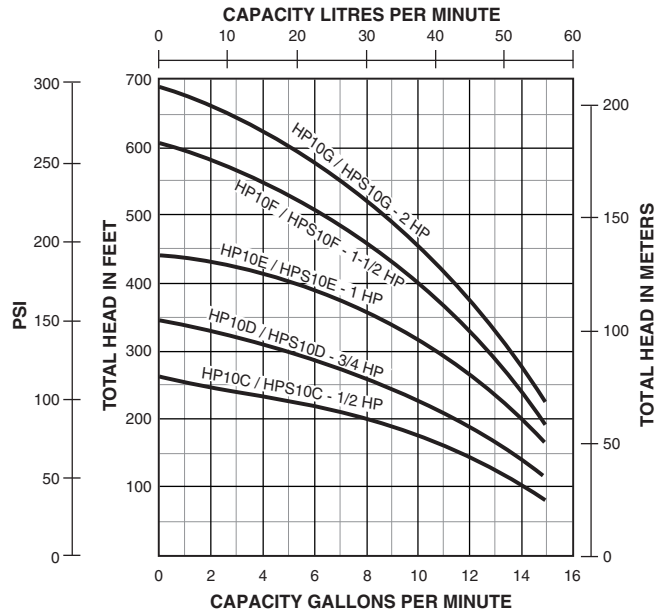

PUMP PERFORMANCE: 20 GPM

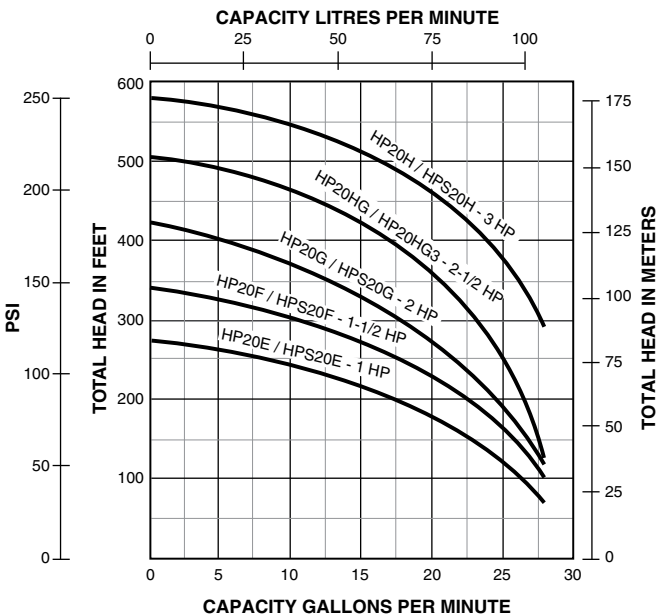

PUMP PERFORMANCE: 30 GPM

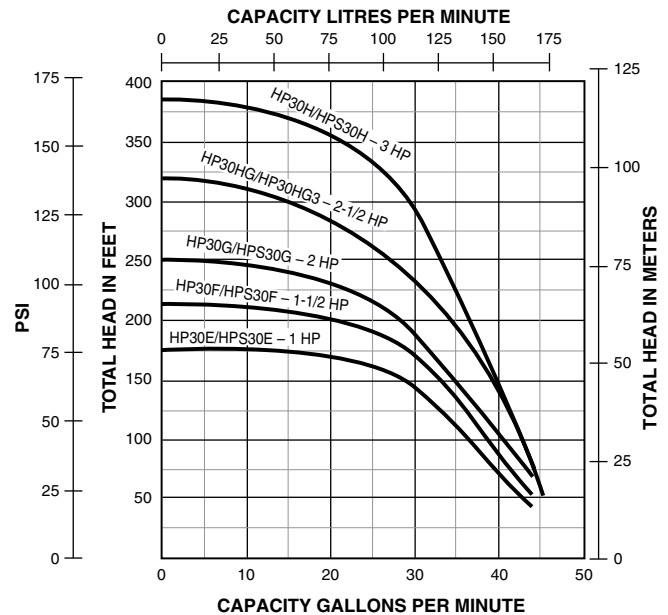

HP/HPS Series Signature 2000®

OUTLINE DIMENSIONS

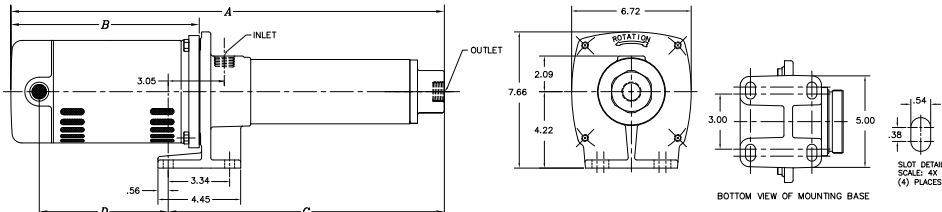

DIMENSIONS: CAST IRON (IN INCHES)

Catalog Number	HP	A	B	C	D
HP7C	1/2	24.60	10.38	15.76	6.88
HP7C3	1/2	23.34	9.12	15.76	7.88
HP7D	3/4	27.73	10.88	18.39	7.88
HP7D3	3/4	27.22	10.38	18.39	7.47
HP7E	1	32.23	11.88	21.89	8.88
HP7E3	1	31.23	10.88	21.89	7.88
HP10C	1/2	23.19	11.60	13.13	8.63
HP10C3	1/2	20.71	9.12	13.13	6.88
HP10D	3/4	25.31	11.97	14.88	9.00
HP10D3	3/4	23.71	10.38	14.88	7.47
HP10E	1	28.12	13.03	16.63	10.06
HP10E3	1	25.97	10.88	16.63	7.88
HP10F	1-1/2	32.07	13.47	20.14	10.50
HP10F3	1-1/2	30.47	11.88	20.14	8.88
HP10G	2	34.13	13.78	21.89	10.81
HP10G3	2	32.97	12.63	21.89	9.63
HP20E	1	26.02	11.88	15.68	8.88
HP20E3	1	25.02	10.88	15.68	7.88
HP20F	1-1/2	29.84	13.47	17.91	10.50
HP20F3	1-1/2	28.24	11.88	17.91	8.88
HP20G	2	32.38	13.78	20.14	10.81
HP20G3	2	31.22	12.63	20.14	9.63
HP20HG	2-1/2	33.82	13.18	22.36	10.25
HP20HG3	2-1/2	33.84	13.20	22.36	10.28
HP20H	3	36.80	14.05	24.47	11.12
HP20H3	3	34.67	11.92	24.47	8.97
HP30E	1	25.08	11.88	14.92	8.69
HP30E3	1	24.08	10.88	14.92	7.69
HP30F	1-1/2	27.26	12.63	16.35	9.44
HP30F3	1-1/2	26.51	11.88	16.35	8.69
HP30G	2	28.49	12.42	17.79	9.47
HP30G3	2	28.70	12.63	17.79	9.44
HP30HG	2-1/2	32.24	13.18	20.78	10.25
HP30HG3	2-1/2	32.26	13.20	20.78	10.28
HP30H	3	35.86	14.05	23.53	11.12
HP30H3	3	33.73	11.92	23.53	8.97

DIMENSIONS: STAINLESS STEEL (IN INCHES)

Catalog Number	HP	A	B	C	D
HPS7C	1/2	25.82	11.60	15.76	8.63
HPS7C3	1/2	23.84	9.12	15.76	6.88
HPS7D	3/4	28.82	11.97	18.39	9.00
HPS7D3	3/4	27.22	10.38	18.39	7.47
HPS7E	1	33.38	13.03	21.89	10.06
HPS7E3	1	31.23	10.88	21.89	7.88
HPS10C	1/2	23.19	11.60	13.13	8.63
HPS10C3	1/2	20.71	9.12	13.13	6.88
HPS10D	3/4	25.31	11.97	14.88	9.00
HPS10D3	3/4	23.71	10.38	14.88	7.47
HPS10E	1	28.12	13.03	16.63	10.06
HPS10E3	1	25.97	10.88	16.63	7.88
HPS10F	1-1/2	32.07	13.47	20.14	10.50
HPS10F3	1-1/2	30.47	11.88	20.14	8.88
HPS10G	2	34.13	13.78	21.89	10.81
HPS10G3	2	32.97	12.63	21.89	9.63
HPS20E	1	26.05	13.03	14.56	10.06
HPS20E3	1	23.90	10.88	14.56	7.88
HPS20F	1-1/2	29.84	13.47	17.91	10.50
HPS20F3	1-1/2	28.24	11.88	17.91	8.88
HPS20G	2	32.38	13.78	20.14	10.81
HPS20G3	2	31.22	12.63	20.14	9.63
HPS20HG	2-1/2	33.82	13.18	22.36	10.28
HPS20HG3	2-1/2	33.84	13.20	22.36	10.28
HPS20H	3	36.80	14.05	24.47	11.12
HPS20H3	3	34.67	11.92	24.47	8.97
HPS30E	1	26.23	13.03	14.92	9.87
HPS30E3	1	24.08	10.88	14.92	7.69
HPS30F	1-1/2	28.10	13.47	16.35	10.31
HPS30F3	1-1/2	26.51	11.88	16.35	8.69
HPS30G	2	29.85	13.78	17.79	10.62
HPS30G3	2	28.70	12.63	17.79	9.44
HPS30HG	2-1/2	32.24	13.18	20.78	10.28
HPS30HG3	2-1/2	32.26	13.20	20.78	10.28
HPS30H	3	35.86	14.05	23.53	11.12
HPS30H3	3	33.73	11.92	23.53	8.97

PRO-SOURCE® Pumper Series

Engine-Driven Pumps

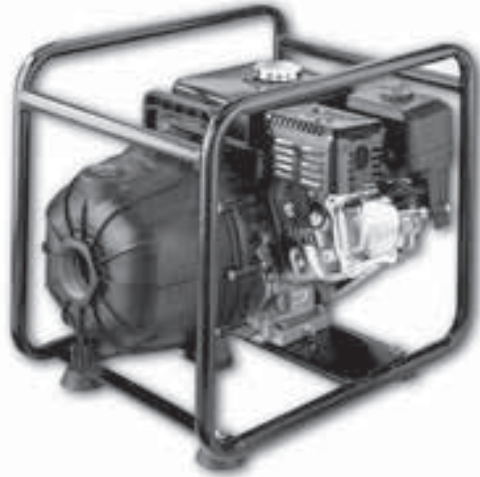

Lightweight, corrosion-resistant, engineered composite pump construction make this engine-driven pump extremely versatile for applications where electrical power is not available.

Powered by a powerful 6-1/2 HP, PowerPro 4-cycle gasoline engine, rated for continuous-duty, equipped with professional-grade features like an automatic low-oil safety cut, manual throttle, choke and shut-off controls.

Securely mounted within a rugged steel framed rollcage, reinforced with steel cross-members, coated for corrosion resistance, equipped with noise-dampening, non-slip rubber feet.

Suction lift capability of 25 feet.

APPLICATIONS

- Water Transfer and Supply
- Sprinkler Turf Irrigation
- Dewatering
- Fire Protection
- Agriculture, Light Commercial and Marine

SPECIFICATIONS

- Body:** Reinforced corrosion-resistant thermoplastic
- Impeller:** Polymer
- Diffuser:** Reinforced corrosion-resistant thermoplastic
- Seals:** Viton mechanical
- O-rings:** Viton
- Check Valve:** Viton
- Rollcage:** Coated steel frame with cross-member and stay-in-place (no-slip) rubber feet
- Engine:** 6-1/2 HP
- Dimensions:** 21"H x 17"D x 21"L
- Fasteners:** 300 grade stainless steel

FEATURES

- Rugged Lightweight Design
- Corrosion-Resistant Composite Pump Construction
- Chemical-Resistant Viton Seals, O-rings with Stainless Steel Fasteners
- Built-in Check Valve

ACCESSORIES

- Suction Hose Kit:** Built-in 2" NPTF swivel fitting and 2" NPTM fitting for easy hookup; coil-reinforced wall prevents collapse; includes aluminum suction screen to prevent debris from reaching pump
- Discharge Hose Kit:** Built-in 2" NPTF swivel fitting and 2" NPTM fitting for easy hookup; collapsible for easy roll-up and storage; reinforced wall adds durability

ORDERING INFORMATION

Catalog Number	HP	Description	Pipe Tapping Sizes		Approx. Wt. Lbs./Kg
			Suction	Discharge	
EDP55RV	6-1/2	Engine-driven pump w/rollcage	2" NPT	2" NPT	46/20.9

ACCESSORIES

Catalog Number	Description	Approx. Wt. Lbs./Kg
FP2735	2" x 15' Suction Hose Kit	15/6.8
FP2731	2" x 25' Discharge Hose Kit	6/2.7



FP2735
Suction
Hose Kit



FP2731
Discharge
Hose Kit

PRO-SOURCE® Pumper Series

Engine-Driven Pumps

PUMP PERFORMANCE

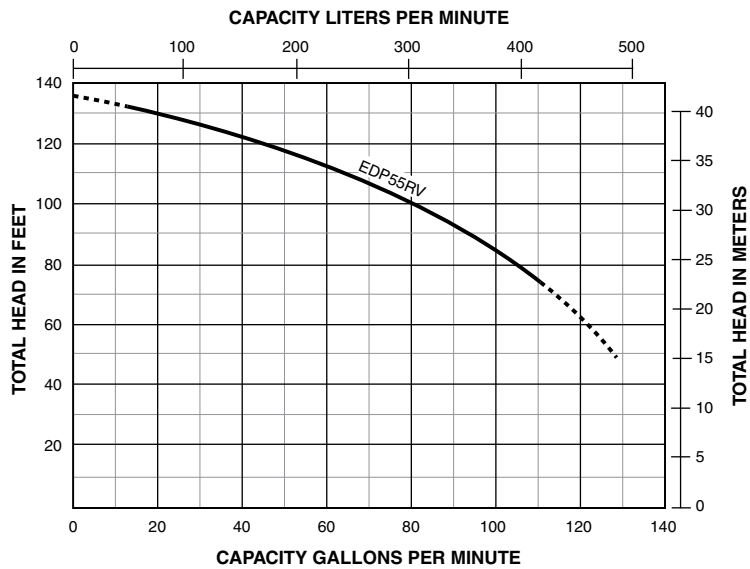

OUTLINE DIMENSIONS

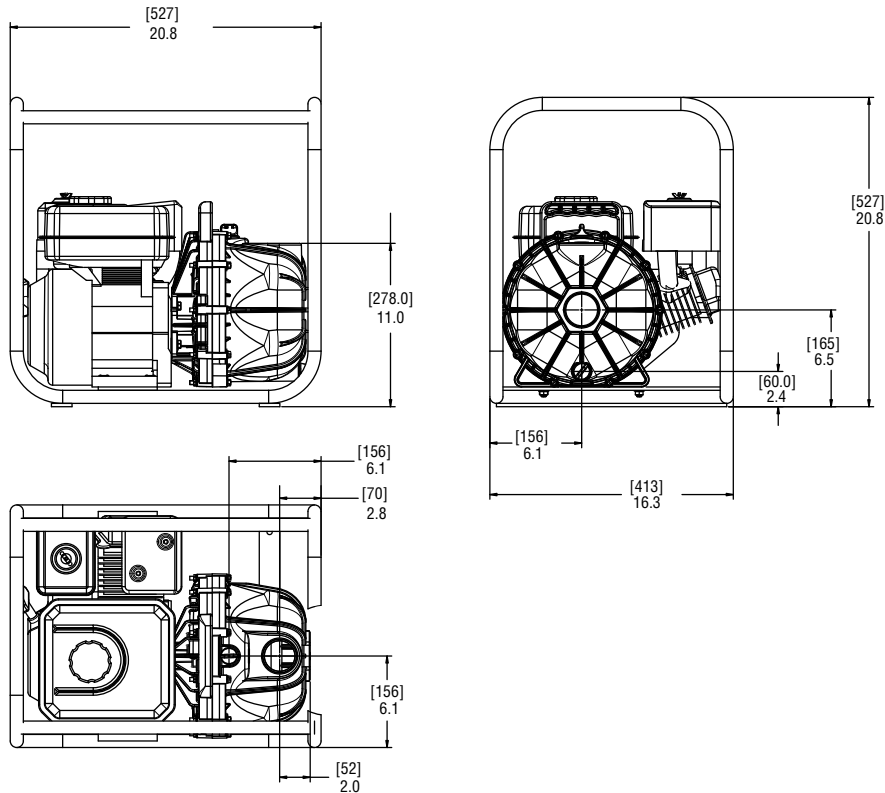

Dimensions (in inches) are for estimating purposes only.

EDD/EEDD Series Engine-Driven Self-Priming Pumps

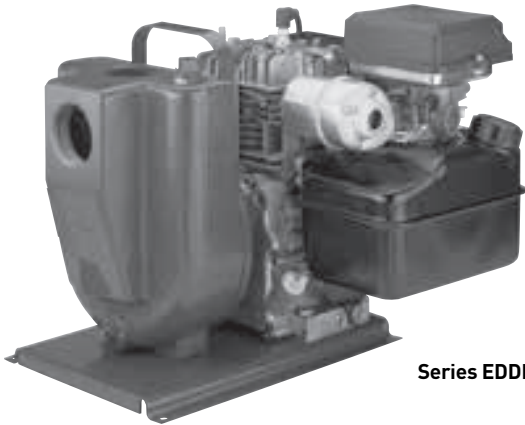

These engine-driven centrifugal pumps can be used where electrical power is not available. Powerful 4-cycle gasoline engines get the job done faster and more efficiently.

Close-coupled EDDH has pump and engine close-coupled on all-steel base...16" long, 14" wide and 13-1/8" high. EDDH features 5/8" diameter, ductile iron threaded shaft extension.

Frame-mounted EEDDH features pump and engine frame-mounted on all-steel base...18-11/16" long, 14" wide and 13-1/8" high. Stub shaft allows easy replacement with other gasoline-powered engines. EEDDH has 3/4" diameter keyed ductile iron shaft extension.

Order Catalog No. EEDD for pump end only, supplied without engine, to be used with 5/8" or 3/4" shaft in gasoline-engine-driven applications. Pump is identical in design to stub-shaft EEDDH.

SPECIFICATIONS

Body: Close-grained cast iron

Impeller: Cast iron

Diffuser: Cast iron

Diffuser Ring: Buna-N

Stub Shaft (EEDD only):
416 stainless steel

ORDERING INFORMATION

Catalog Number	HP	Description	Fuel Tank Size	Pipe Tapping Sizes		Approx. Wt. Lbs.
				Suction	Discharge	
EDDH	3	Gasoline-powered pump	3 Quarts	2"	2"	65
EEDDH	3	Gasoline-powered pump	3 Quarts	2"	2"	70
EEDD	-	Gasoline-powered pump	-	2"	2"	38

Design Series EDDH – Engine-driven without stub shaft

Design Series EEDDH – Engine-driven with stub shaft

Design Series EEDD – Stub shaft pump only

EDD/EEDD Series Engine-Driven Self-Priming Pumps

OUTLINE DIMENSIONS: EEDD

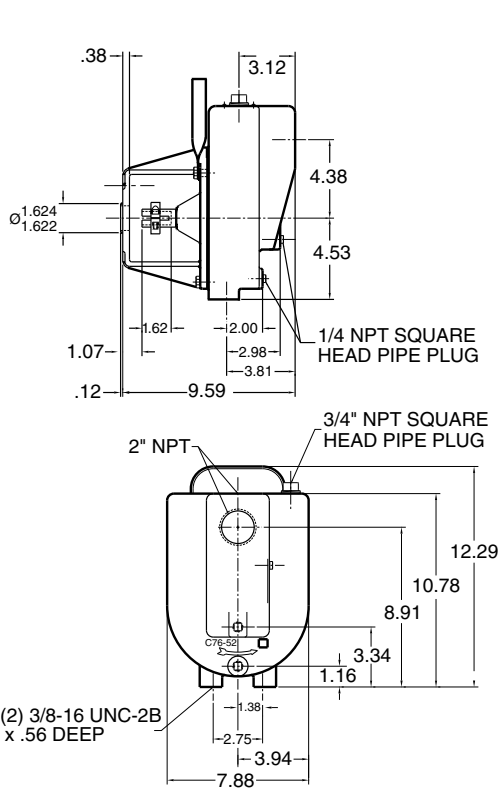

OUTLINE DIMENSIONS: EEDDH

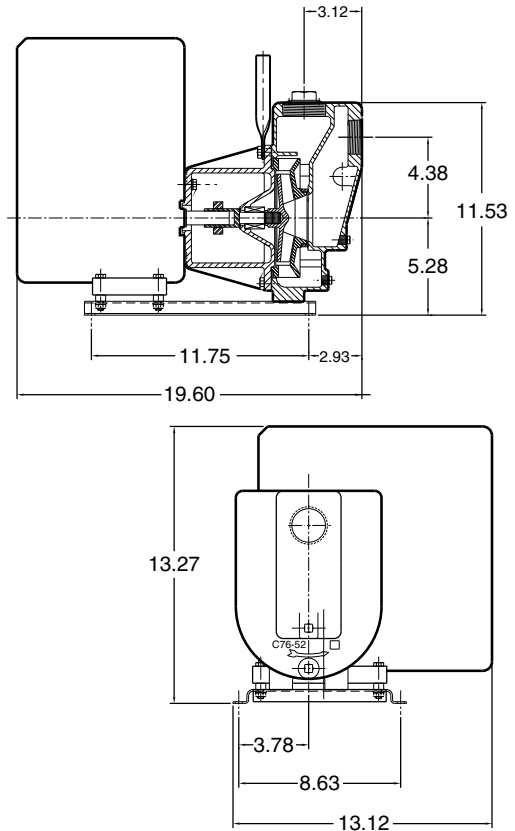

Dimensions (in inches) are for estimating purposes only.

PUMP PERFORMANCE

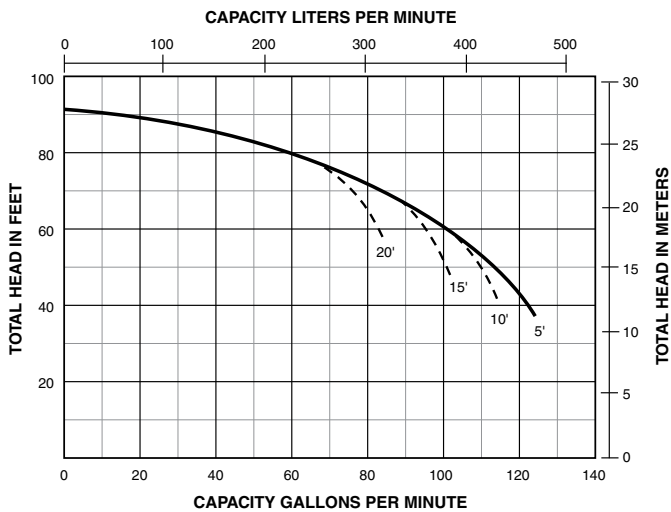

NOTE: Dotted lines indicate performance reduction at high suction lift.

Water Systems Product Nomenclature

Sta-Rite® Catalog Numbers define products for you.

The following paragraphs describe number assignments and their meanings for 4" submersibles, jets and small centrifugal pumps.

4" SUBMERSIBLE PUMP CATALOG NUMBERS

Submersible pump catalog numbers are patterned like this:

S10P4HS05221

	(1)	(2)	(3)	(4)	(5)	(6)	(7)	(8)
	Brand	GPM	Motor Type Motor Size	Pump Series	HP	Volts	No. of Wires	Phase
example:	S	10	P4	HS	05	2	2	1

Brand:
S - Sta-Rite

GPM:
Gallons Per Minute
Current sizes: 5, 7, 10, 15, 20, 30
for the 4" Series.

Type:
P4 - Pentek® four inch

Pump Series:
HS: "H" Series Stainless Steel
JP: "J" Series Plastic
HS+: "H+" Series Stainless Steel

Volts:
1 = 115V
2 = 230V

HP: Horsepower
Horsepower designation for all Sta-Rite pumps:
05 = .5 HP
07 = .75 HP
10 = 1 HP
15 = 1.5 HP

Phase:
1 = Single

No. of Wires:
2 = 2-wire
3 = 3-wire

Water Systems Product Nomenclature

JET PUMP CATALOG NUMBERS

Jet pump catalog numbers are patterned like this:

SNC-L

	(1)	(2)	(3)
	type	HP	dash#
example:	SN	C	-L

(1) **type: PUMP DESIGN SERIES**

(2) **HP: HORSEPOWER**

Horsepower designation for all Sta-Rite Pumps:

B = 1/3 HP E = 1 HP
 C = 1/2 HP F = 1-1/2 HP
 D = 3/4 HP G = 2 HP

(3) **dash#: ENGINEERING SERIES NUMBER (dash number)**

Indicates small product improvements.

STEEL TANK CATALOG NUMBERS

Steel tank catalog numbers are patterned like this:

PS19T

	(1)	(2)	(3)
	type	size	dash#
example:	PS	19T	-T02

(1) **type: TANK DESIGN SERIES**

(2) **size: Tank size equivalent to traditional galvanized air-over-water tank**

T = "tall" stand-up type
 H = "horizontal" pump mount type

(3) **dash#: ENGINEERING SERIES NUMBER (dash number)**

Indicates small product improvements.

SMALL CENTRIFUGAL PUMP CATALOG NUMBERS

Centrifugal pump catalog numbers are patterned like this:

DS3HE

	(1)	(2)	(3)	(4)
	type	head	HP	dash#
example:	DS3	H	E	-01

(1) **type: PUMP DESIGN SERIES**

(2) **head: HEAD DESIGN**

H = high head

(3) **HP: HORSEPOWER**

Horsepower designation for all Sta-Rite Pumps:

B = 1/3 HP G = 2 HP
 C = 1/2 HP HG = 2-1/2 HP
 D = 3/4 HP H = 3 HP
 E = 1 HP J = 5 HP
 F = 1-1/2 HP

Note that there is no unique letter for a 2-1/2 HP motor. When the head designator is doubled as in "HH" followed by a "G" horsepower code, the motor will be a 2-1/2 HP.

(4) **dash#: ENGINEERING SERIES NUMBER (dash number)**

Indicates small product improvements.

FIBREWOUND TANKS

Fibrewound tank catalog numbers are patterned like this:

PSC35-10

	(1)	(2)	(3)	(4)
	type	size	drawdown	dash#
example:	PSC	35	-10	-01

(1) **type: TANK DESIGN SERIES**

(2) **size: Tank vessel capacity in U.S. gallons**

(3) **drawdown: U.S. gallons drawdown with a 30-50 system pressure**

(4) **dash#: ENGINEERING SERIES NUMBER (dash number)**

Indicates small product improvements.

Sizing Home Water Systems

Pentair has developed the following “Rule of Thumb” formula for sizing home water systems that will be applicable in many instances:

Simply count the fixtures and water outlets in the home. This method bases the approximate pumping capacity on use at the rate of a gallon per minute per fixture, and avoids the possibility of undersizing.

For instance, let us assume you count the following list of fixtures and water outlets in your home:

Kitchen:	Sink/Dishwasher	1
	(count as 1 fixture)	1
Bath:	Lavatory	1
	Tub	1
	Toilet	1
Powder Room:	Lavatory	1
	Toilet	1
Laundry and Utility Room:		
	Automatic washing machine (count as one fixture)	1
	Laundry tubs	1
	Shower	1
	Outdoor faucets	2
Total fixtures and outlets		12

Be sure that your pump installer provides a water system that will deliver 12 gallons per minute at the desired pressure.

Average Water Requirements for General Service Around the Home and Farm

Each person per day, for all purposes	50 gal.
Each horse, dry cow or beef animal per day	12 gal.
Each milking cow per day	35 gal.
Each hog per day	4 gal.
Each sheep per day	2 gal.
Each 100 chickens per day	4 gal.

Average Amount of Water Required By Various Home and Yard Fixtures

Drinking fountain, continuously flowing, 50 to 100 gal. per day	
Each shower bath	Up to 60 gal.
To fill bathtub	30 gal.
To flush toilet	6 gal.
To fill lavatory	2 gal.
To sprinkle 1/4" of water on each	
1000 sq. feet of lawn	160 gal.
Dishwasher – per load	3 gal.
Automatic washer – per load	Up to 50 gal.
Regeneration of domestic water softener	50-100 gal.

Average Flow Rate Requirements by Various Fixtures

(GPM equals gallons per minute; GPH equals gallons per hour)

Shower	4 to 6 GPM
Bathtub	4 to 8 GPM
Toilet	4 to 5 GPM
Lavatory	1 to 3 GPM
Kitchen sink	2 to 3 GPM
1/2" hose and nozzle	200 GPH
3/4" hose and nozzle	300 GPH
Lawn sprinkler	120 GPH

Pounds Pressure – Feet of Head

Each pound of pressure developed by a pumping system is equal to 2.31 feet of head (feet of lift). Therefore, 10 pounds of pressure (PSI) will lift water vertically 23.1 feet. The following chart converts pressure to feet of head at various settings from 1 to 100 PSI.

This can be calculated for any setting using the following formula:

$$\text{Pounds per Sq. Inch} = \frac{\text{Head in Feet}}{2.31}$$

$$\text{Head in Feet} = \text{Pounds per Sq. In.} \times 2.31$$

CONVERSION TABLE

POUNDS PRESSURE/FEET OF HEAD

Pounds Pressure	Feet of Head
1	2.31
5	11.6
10	23.1
15	34.7
20	46.2
25	57.7
30	69.3
35	80.8
40	92.4
45	103.9
50	115.5
60	138.6
65	150.1
70	161.7
75	173.2
80	184.8
85	196.3
90	207.9
95	219.4
100	231.0

Pipe Friction Loss Charts 1/2"-1-1/4" I.D.

LOSS OF HEAD IN FEET DUE TO FRICTION PER 100 FEET OF PIPE

1/2"					3/4"					1"					1-1/4"				
Flow U.S. Gal. Min.	Velocity Plastic ft/sec	Plastic C=140 ID .622"	Steel C=100 ID .622"	Copper C=130 ID .625"	Flow U.S. Gal. Min.	Velocity Plastic ft/sec	Plastic C=140 ID .824"	Steel C=100 ID .824"	Copper C=130 ID .822"	Flow U.S. Gal. Min.	Velocity Plastic ft/sec	Plastic C=140 ID 1.049"	Steel C=100 ID 1.049"	Copper C=130 ID 1.062"	Flow U.S. Gal. Min.	Velocity Plastic ft/sec	Plastic C=140 ID 1.380"	Steel C=100 ID 1.380"	Copper C=130 ID 1.368"
0.5	0.5	0.314	0.582	0.35	1.5	0.9	0.61	1.13	0.7	2	0.74	0.322	0.595	0.345	4	0.9	0.304	0.564	0.364
1	1.1	1.14	2.1	1.26	2	1.2	1.04	1.93	1.21	3	1.1	0.68	1.26	0.732	5	1.1	0.46	0.853	0.545
1.5	1.6	2.38	4.44	2.67	2.5	1.5	1.57	2.91	1.82	4	1.5	1.15	2.14	1.24	6	1.3	0.649	1.2	0.765
2	2.1	4.1	7.57	4.56	3	1.8	2.21	4.08	2.56	5	1.9	1.75	3.42	1.88	7	1.5	0.86	1.59	1.02
2.5	2.6	6.15	11.4	6.88	3.5	2.1	2.93	5.42	3.4	6	2.2	2.45	4.54	2.63	8	1.7	1.1	2.04	1.31
3	3.2	8.65	16	9.66	4	2.4	3.74	6.94	4.36	8	3.0	4.16	7.73	4.5	10	2.1	1.67	3.08	1.98
3.5	3.7	11.5	21.3	12.9	4.5	2.7	4.66	8.63	5.4	10	3.7	6.31	11.7	6.77	12	2.6	2.33	4.31	2.75
4	4.2	14.8	27.3	16.4	5	3.0	5.66	10.5	6.57	12	4.5	8.85	16.4	9.47	14	3.0	3.1	5.73	3.64
4.5	4.8	18.3	33.9	20.4	6	3.6	7.95	14.7	9.22	14	5.2	11.8	21.8	12.6	16	3.4	3.96	7.34	4.68
5	5.3	22.2	41.2	24.8	7	4.2	10.6	19.6	12.2	16	5.9	15.1	27.9	16.2	18	3.9	4.93	9.13	5.81
5.5	5.8	26.6	49.2	29.5	8	4.8	13.5	25	15.7	18	6.7	18.7	34.7	20.1	20	4.3	6	11.1	7.1
6	6.3	31.2	57.8	34.8	9	5.4	16.8	31.1	19.5	20	7.4	22.8	42.1	24.4	25	5.4	9.06	16.8	10.7
6.5	6.9	36.2	67	40.2	10	6.0	20.4	37.8	23.7	22	8.2	27.1	50.2	28.8	30	6.4	12.7	23.5	15
7	7.4	41.5	76.8	46.1	11	6.6	24.4	45.1	28.2	24	8.9	31.9	59	34	35	7.5	16.9	31.2	20
7.5	7.9	47.2	87.3	52.5	12	7.2	28.6	53	33.2	26	9.7	36.9	68.4	39.7	40	8.6	21.6	40	25.6
8	8.4	53	98.3	59.4	13	7.8	33.2	61.5	38.5	28	10.4	42.5	78.5	45.5	50	10.7	32.6	60.4	38.7
8.5	9.0	59.5	110	66	14	8.4	38	70.5	44.2	30	11.1	48.1	89.2	51.6	60	12.9	45.6	84.7	54.1
9	9.5	66	122	73.5	16	9.6	48.6	90.2	56.6	35	13.0	64.3	119	68.7	70	15.0	61.5	114	72.2
9.5	10.0	73	135	81	18	10.8	60.5	112	70.4	40	14.8	82	152	88	80	17.2	77.9	144	92.4
10	10.6	80.5	149	89.4	20	12.0	73.5	136	83.5	45	16.7	102	189	109	90	19.3	96.6	179	115

NOTE: Recommended velocity is 5 FPS (feet per second) with a maximum of 7 FPS.

FRICTION LOSSES THROUGH FITTINGS IN TERMS OF EQUIVALENT LENGTHS OF PIPE

Type Fitting and Application	Pipe and Fitting Material (Note 1)	Equivalent Length of Pipe – Nominal Size Fitting and Pipe						
		1/2	3/4	1	1-1/4	1-1/2	2	2-1/2
Threaded Adapter Plastic or Copper to Thread	Copper	1	1	1	1	1	1	1
	Plastic	3	3	3	3	3	3	3
90° Standard Elbow	Steel	2	3	3	4	4	5	6
	Copper	2	3	3	4	4	5	6
	Plastic	4	5	6	7	8	9	10
Insert Coupling	Plastic	3	3	3	3	3	3	3
Standard Tee	Steel	4	5	6	8	9	11	14
	Copper	4	5	6	8	9	11	14
	Plastic	7	8	9	12	13	17	20
Gate Valve	Note (2)	2	3	4	5	6	7	8

Note (1) Loss Figures are based on equivalent lengths of indicated pipe material.

Note (2) Loss Figures for screwed valves are based on equivalent lengths of steel pipe.

Pipe Friction Loss Charts 1-1/2"-2-1/2" I.D.

LOSS OF HEAD IN FEET DUE TO FRICTION PER 100 FEET OF PIPE

1-1/2"					2"					2-1/2"				
Flow U.S. Gal. Min.	Velocity Plastic ft/sec	Plastic C=140 ID 1.61"	Steel C=100 ID 1.61"	Copper C=130 ID 1.60"	Flow U.S. Gal. Min.	Velocity Plastic ft/sec	Plastic C=140 ID 2.067"	Steel C=100 ID 2.067"	Copper C=130 ID 2.062"	Flow U.S. Gal. Min.	Velocity Plastic ft/sec	Plastic C=140 ID 2.469"	Steel C=100 ID 2.469"	Copper C=130 ID 2.50"
4	0.6	0.144	0.267	0.165	10	1.0	0.233	0.431	0.268	20	1.3	0.353	0.654	0.375
6	0.9	0.305	0.565	0.358	15	1.4	0.495	0.916	0.569	30	2.0	0.75	1.39	0.792
8	1.3	0.52	0.962	0.611	20	1.9	0.839	1.55	0.962	40	2.7	1.27	2.36	1.35
10	1.6	0.785	1.45	0.923	25	2.4	1.27	2.35	1.45	50	3.4	1.92	3.56	2.04
12	1.9	1.1	2.04	1.29	30	2.9	1.78	3.29	2.03	60	4.0	2.69	4.99	2.86
14	2.2	1.46	2.71	1.71	35	3.3	2.36	4.37	2.71	70	4.7	3.58	6.64	3.82
16	2.5	1.87	3.47	2.2	40	3.8	3.03	5.6	3.47	80	5.4	4.59	8.5	4.88
18	2.8	2.33	4.31	2.75	45	4.3	3.76	6.96	4.31	90	6.0	5.72	10.6	6.06
20	3.2	2.83	5.24	3.31	50	4.8	4.57	8.46	5.24	100	6.7	6.9	12.8	7.37
25	3.9	4.26	7.9	5	55	5.3	5.46	10.1	6.22	110	7.4	8.25	15.3	8.8
30	4.7	6	11.1	7	60	5.7	6.44	11.9	7.34	120	8.0	9.71	18	10.3
35	5.5	7.94	14.7	9.35	70	6.7	8.53	15.8	9.78	130	8.7	11.3	20.9	12
40	6.3	10.2	18.9	12	80	7.6	10.9	20.2	12.5	140	9.4	12.9	23.9	13.7
45	7.1	12.63	23.4	14.9	90	8.6	13.6	25.1	15.6	150	10.1	14.7	27.3	15.6
50	7.9	15.4	28.5	18.1	100	9.6	16.5	30.5	18.9	160	10.7	16.6	30.7	17.6
55	8.7	18.35	34	21.5	110	10.5	19.7	36.4	22.5	170	11.4	18.5	34.3	19.7
60	9.5	21.6	40	25.3	120	11.5	23.1	42.7	26.6	180	12.1	20.6	38.1	21.9
65	10.2	25.1	46.4	29	130	12.4	26.8	49.6	30.7	190	12.7	22.7	42.1	24.2
70	11.0	28.7	53.2	33.8	140	13.4	30.6	56.9	35.2	200	13.4	25	46.3	26.6
75	11.8	32.6	60.4	38	150	14.3	35	64.7	40.1	220	14.7	29.8	55.3	31.8
80	12.6	36.8	68.1	43.1	160	15.3	39.3	72.8	45.1	240	16.1	35.8	66.4	37.4
85	13.4	41.2	76.2	47.6	170	16.3	44	81.4	50.5	260	17.4	41.6	75.3	43.3
90	14.2	45.7	84.7	53.6	180	17.2	48.9	90.5	56.1	280	18.8	46.6	86.3	49.4
95	15.0	50.5	93.6	58.8	190	18.2	54	100	62	300	20.1	52.9	98.1	56.8
100	15.8	56.6	103	65.1	200	19.1	59.4	110	68					

NOTE: Recommended velocity is 5 FPS (feet per second) with a maximum of 7 FPS.

Note (1) Loss Figures are based on equivalent lengths of indicated pipe material

Note (2) Loss Figures for screwed valves based on equivalent lengths of steel pipe.

Cable Selection Guide

Hitachi 6"–8" Submersible Motors

CABLE SELECTION																				60° C				
COPPER CABLE SIZE - From Control Box to Motor (in feet)																								
MOTOR				AWG														MCM						
VOLTS / HZ	HP	KW	FUSE		14	12	10	8	6	4	3	2	1	0	00	000	0000	250	300	350	400	500		
			STD	Dual Element																				
THREE PHASE																								
230 V 60 Hz	5	4	45	25	149	237	378	598	931	1484	1865	2356	2967	3746	4726	5966	7516	8873						
	8	6	60	35	-	-	247	391	609	970	1220	1540	1940	2449	3090	3901	4914	5802	6965	8142	9308			
	10	8	80	45	-	-	-	308	479	764	961	1213	1529	1930	2434	3073	3872	4571	5488	6415	7334	9125		
	15	11	125	70	-	-	-	221	344	548	689	871	1097	1384	1746	2205	2778	3279	3937	4602	5261	6546		
	20	15	150	90	-	-	-	-	264	420	528	667	841	1061	1339	1690	2130	2514	3018	3528	4034	5019		
	25	19	200	100	-	-	-	-	-	332	417	527	664	838	1057	1334	1681	1985	2383	2785	3184	3962		
	30	22	225	125	-	-	-	-	-	-	337	426	537	677	855	1079	1359	1605	1926	2252	2575	3203		
40*	30	300	175	-	-	-	-	-	-	-	328	413	522	659	831	1047	1236	1484	1735	1984	2468			
460 V 60 Hz	5	4	20	10	595	947	1511	2393	3723	5935	7461	9422												
	8	6	30	15	389	619	988	1564	2434	3880	4878	6161	7761	9797										
	10	8	40	20	307	488	778	1233	1918	3057	3844	4854	6115	7719	9738									
	15	11	60	30	-	350	558	884	1376	2193	2757	3482	4387	5537	6986	8819								
	20	15	80	45	-	-	428	678	1055	1682	2114	2670	3363	4245	5356	6761	8518							
	25	19	100	50	-	-	-	535	833	1328	1669	2108	2655	3351	4228	5338	6725	7939	9531					
	30	22	110	60	-	-	-	433	673	1073	1349	1704	2147	2710	3419	4316	5437	6419	7706	9008				
	40	30	150	80	-	-	-	-	519	827	1040	1313	1654	2088	2634	3325	4189	4946	5937	6940	7935	9873		
	40*	30	150	80	-	-	-	-	502	801	1007	1271	1601	2022	2550	3220	4056	4789	5749	6720	7683	9559		
	50	37	175	100	-	-	-	-	-	639	803	1014	1277	1612	2034	2568	3235	3819	4585	5359	6127	7623		
	50*	37	175	100	-	-	-	-	-	691	869	1097	1382	1745	2201	2779	3501	4133	4961	5799	6631	8250		
	60	45	225	125	-	-	-	-	-	-	675	852	1073	1355	1709	2158	2719	3210	3853	4504	5149	6407		
	60*	45	225	125	-	-	-	-	-	-	705	890	1121	1415	1785	2254	2839	3352	4024	4704	5378	6691		
	75	55	250	150	-	-	-	-	-	-	-	735	926	1168	1474	1861	2344	2768	3323	3884	4441	5525		
	100	75	350	200	-	-	-	-	-	-	-	-	-	-	878	1108	1399	1762	2081	2498	2920	3338	4153	
125	93	450	250	-	-	-	-	-	-	-	-	-	-	-	893	1127	1420	1676	2012	2352	2689	3346		
150	111	500	275	-	-	-	-	-	-	-	-	-	-	-	-	-	1162	1371	1646	1924	2200	2737		

Lengths only meet the US National Electrical Code ampacity requirements for individual conductors rated 60° C in free air or water, NOT in magnetic enclosures, conduit or direct buried. Refer to NEC Table 310.15(B)(17) for more information.

* = motors are 8" diameter

Cable Selection Guide

Hitachi 6"–8" Submersible Motors

CABLE SELECTION																				75° C				
COPPER CABLE SIZE - From Control Box to Motor (in feet)																								
MOTOR				AWG														MCM						
VOLTS / HZ	HP	KW	FUSE		14	12	10	8	6	4	3	2	1	0	00	000	0000	250	300	350	400	500		
			STD	Dual Element																				
THREE PHASE																								
230 V 60 Hz	5	4	45	25	149	237	378	598	931	1484	1865	2356	2967	3746	4726	5966	7516	8873						
	8	6	60	35	-	155	247	391	609	970	1220	1540	1940	2449	3090	3901	4914	5802	6965	8142	9308			
	10	8	80	45	-	-	195	308	479	764	961	1213	1529	1930	2434	3073	3872	4571	5488	6415	7334	9125		
	15	11	125	70	-	-	-	221	344	548	689	871	1097	1384	1746	2205	2778	3279	3937	4602	5261	6546		
	20	15	150	90	-	-	-	-	264	420	528	667	841	1061	1339	1690	2130	2514	3018	3528	4034	5019		
	25	19	200	100	-	-	-	-	208	332	417	527	664	838	1057	1334	1681	1985	2383	2785	3184	3962		
	30	22	225	125	-	-	-	-	-	268	337	426	537	677	855	1079	1359	1605	1926	2252	2575	3203		
40*	30	300	175	-	-	-	-	-	-	-	328	413	522	659	831	1047	1236	1484	1735	1984	2468			
460 V 60 Hz	5	4	20	10	595	947	1511	2393	3723	5935	7461	9422												
	8	6	30	15	389	619	988	1564	2434	3880	4878	6161	7761	9797										
	10	8	40	20	307	488	778	1233	1918	3057	3844	4854	6115	7719	9738									
	15	11	60	30	220	350	558	884	1376	2193	2757	3482	4387	5537	6986	8819								
	20	15	80	45	-	-	428	678	1055	1682	2114	2670	3363	4245	5356	6761	8518							
	25	19	100	50	-	-	338	535	833	1328	1669	2108	2655	3351	4228	5338	6725	7939	9531					
	30	22	110	60	-	-	-	433	673	1073	1349	1704	2147	2710	3419	4316	5437	6419	7706	9008				
	40	30	150	80	-	-	-	-	519	827	1040	1313	1654	2088	2634	3325	4189	4946	5937	6940	7935	9873		
	40*	30	150	80	-	-	-	-	502	801	1007	1271	1601	2022	2550	3220	4056	4789	5749	6720	7683	9559		
	50	37	175	100	-	-	-	-	-	639	803	1014	1277	1612	2034	2568	3235	3819	4585	5359	6127	7623		
	50*	37	175	100	-	-	-	-	433	691	869	1097	1382	1745	2201	2779	3501	4133	4961	5799	6631	8250		
	60	45	225	125	-	-	-	-	-	537	675	852	1073	1355	1709	2158	2719	3210	3853	4504	5149	6407		
	60*	45	225	125	-	-	-	-	-	561	705	890	1121	1415	1785	2254	2839	3352	4024	4704	5378	6691		
	75	55	250	150	-	-	-	-	-	-	582	735	926	1168	1474	1861	2344	2768	3323	3884	4441	5525		
	100	75	350	200	-	-	-	-	-	-	-	-	-	696	878	1108	1399	1762	2081	2498	2920	3338	4153	
	125	93	450	250	-	-	-	-	-	-	-	-	-	-	708	893	1127	1420	1676	2012	2352	2689	3346	
150	111	500	275	-	-	-	-	-	-	-	-	-	-	-	922	1162	1371	1646	1924	2200	2737			

Lengths only meet the US National Electrical Code ampacity requirements for individual conductors rated 75° C in free air or water, NOT in magnetic enclosures, conduit or direct buried. Refer to NEC Table 310.15(B)(17) for more information.

* = motors are 8" diameter

Cable Selection Guide

Hitachi 6"–8" Submersible Motors

CABLE SELECTION																				60° C				
COPPER CABLE SIZE - From Control Box to Motor (in feet)																								
MOTOR				AWG													MCM							
VOLTS	HP	KW	FUSE		14	12	10	8	6	4	3	2	1	0	00	000	0000	250	300	350	400	500		
			STD	Dual Element																				
THREE PHASE																								
230 V 60 Hz	5	4	45	25	-	-	378	598	931	1484	1865	2356	2967	3746	4726	5966	7516	8873						
	8	6	60	35	-	-	-	391	609	970	1220	1540	1940	2449	3090	3901	4914	5802	6965	8142	9308			
	10	8	80	45	-	-	-	-	479	764	961	1213	1529	1930	2434	3073	3872	4571	5488	6415	7334	9125		
	15	11	125	70	-	-	-	-	-	548	689	871	1097	1384	1746	2205	2778	3279	3937	4602	5261	6546		
	20	15	150	90	-	-	-	-	-	-	528	667	841	1061	1339	1690	2130	2514	3018	3528	4034	5019		
	25	19	200	100	-	-	-	-	-	-	-	527	664	838	1057	1334	1681	1985	2383	2785	3184	3962		
	30	22	225	125	-	-	-	-	-	-	-	-	677	855	1079	1359	1605	1926	2252	2575	3203			
40*	30	300	175	-	-	-	-	-	-	-	-	-	-	-	831	1047	1236	1484	1735	1984	2468			
460 V 60 Hz	5	4	20	10	595	947	1511	2393	3723	5935	7461	9422												
	8	6	30	15	-	619	988	1564	2434	3880	4878	6161	7761	9797										
	10	8	40	20	-	-	778	1233	1918	3057	3844	4854	6115	7719	9738									
	15	11	60	30	-	-	558	884	1376	2193	2757	3482	4387	5537	6986	8819								
	20	15	80	45	-	-	-	678	1055	1682	2114	2670	3363	4245	5356	6761	8518							
	25	19	100	50	-	-	-	-	833	1328	1669	2108	2655	3351	4228	5338	6725	7939	9531					
	30	22	110	60	-	-	-	-	-	1073	1349	1704	2147	2710	3419	4316	5437	6419	7706	9008				
	40	30	150	80	-	-	-	-	-	-	1040	1313	1654	2088	2634	3325	4189	4946	5937	6940	7935	9873		
	40*	30	150	80	-	-	-	-	-	-	1007	1271	1601	2022	2550	3220	4056	4789	5749	6720	7683	9559		
	50	37	175	100	-	-	-	-	-	-	-	-	1277	1612	2034	2568	3235	3819	4585	5359	6127	7623		
	50*	37	175	100	-	-	-	-	-	-	-	1097	1382	1745	2201	2779	3501	4133	4961	5799	6631	8250		
	60	45	225	125	-	-	-	-	-	-	-	-	-	1355	1709	2158	2719	3210	3853	4504	5149	6407		
	60*	45	225	125	-	-	-	-	-	-	-	-	-	1415	1785	2254	2839	3352	4024	4704	5378	6691		
	75	55	250	150	-	-	-	-	-	-	-	-	-	-	1474	1861	2344	2768	3323	3884	4441	5525		
	100	75	350	200	-	-	-	-	-	-	-	-	-	-	-	-	1762	2081	2498	2920	3338	4153		
125	93	450	250	-	-	-	-	-	-	-	-	-	-	-	-	-	-	2012	2352	2689	3346			
150	111	500	275	-	-	-	-	-	-	-	-	-	-	-	-	-	-	-	-	-	2200	2737		

Lengths meet the US National Electrical Code ampacity requirements for either individual conductors or jacketed rated 60° C cable and can be in conduit or direct buried. Flat molded and web/ribbon cable are considered jacketed cable. Refer to NEC Table 310.15(B)(16) for more information.

* = motors are 8" diameter

Cable Selection Guide

Hitachi 6"–8" Submersible Motors

CABLE SELECTION																				75° C				
COPPER CABLE SIZE - From Control Box to Motor (in feet)																								
MOTOR				AWG													MCM							
VOLTS	HP	KW	FUSE		14	12	10	8	6	4	3	2	1	0	00	000	0000	250	300	350	400	500		
			STD	Dual Element																				
THREE PHASE																								
230 V 60 Hz	5	4	45	25	-	237	378	598	931	1484	1865	2356	2967	3746	4726	5966	7516	8873						
	8	6	60	35	-	-	247	391	609	970	1220	1540	1940	2449	3090	3901	4914	5802	6965	8142	9308			
	10	8	80	45	-	-	-	308	479	764	961	1213	1529	1930	2434	3073	3872	4571	5488	6415	7334	9125		
	15	11	125	70	-	-	-	344	548	689	871	1097	1384	1746	2205	2778	3279	3937	4602	5261	6546			
	20	15	150	90	-	-	-	-	420	528	667	841	1061	1339	1690	2130	2514	3018	3528	4034	5019			
	25	19	200	100	-	-	-	-	-	417	527	664	838	1057	1334	1681	1985	2383	2785	3184	3962			
	30	22	225	125	-	-	-	-	-	-	-	-	537	677	855	1079	1359	1605	1926	2252	2575	3203		
40*	30	300	175	-	-	-	-	-	-	-	-	-	-	659	831	1047	1236	1484	1735	1984	2468			
460 V 60 Hz	5	4	20	10	595	947	1511	2393	3723	5935	7461	9422												
	8	6	30	15	389	619	988	1564	2434	3880	4878	6161	7761	9797										
	10	8	40	20	-	488	778	1233	1918	3057	3844	4854	6115	7719	9738									
	15	11	60	30	-	-	558	884	1376	2193	2757	3482	4387	5537	6986	8819								
	20	15	80	45	-	-	-	678	1055	1682	2114	2670	3363	4245	5356	6761	8518							
	25	19	100	50	-	-	-	535	833	1328	1669	2108	2655	3351	4228	5338	6725	7939	9531					
	30	22	110	60	-	-	-	-	673	1073	1349	1704	2147	2710	3419	4316	5437	6419	7706	9008				
	40	30	150	80	-	-	-	-	-	827	1040	1313	1654	2088	2634	3325	4189	4946	5937	6940	7935	9873		
	40*	30	150	80	-	-	-	-	-	801	1007	1271	1601	2022	2550	3220	4056	4789	5749	6720	7683	9559		
	50	37	175	100	-	-	-	-	-	-	803	1014	1277	1612	2034	2568	3235	3819	4585	5359	6127	7623		
	50*	37	175	100	-	-	-	-	-	-	869	1097	1382	1745	2201	2779	3501	4133	4961	5799	6631	8250		
	60	45	225	125	-	-	-	-	-	-	-	-	1073	1355	1709	2158	2719	3210	3853	4504	5149	6407		
	60*	45	225	125	-	-	-	-	-	-	-	890	1121	1415	1785	2254	2839	3352	4024	4704	5378	6691		
	75	55	250	150	-	-	-	-	-	-	-	-	-	1168	1474	1861	2344	2768	3323	3884	4441	5525		
	100	75	350	200	-	-	-	-	-	-	-	-	-	-	-	1399	1762	2081	2498	2920	3338	4153		
125	93	450	250	-	-	-	-	-	-	-	-	-	-	-	-	1420	1676	2012	2352	2689	3346			
150	111	500	275	-	-	-	-	-	-	-	-	-	-	-	-	-	-	1646	1924	2200	2737			

Lengths meet the US National Electrical Code ampacity requirements for either individual conductors or jacketed rated 75° C cable and can be in conduit or direct buried. Flat molded and web/ribbon cable are considered jacketed cable. Refer to NEC Table 310.15(B)(16) for more information.

* = motors are 8" diameter

Cable Selection Guide

PENTEK® 6" Submersible Motors

CABLE SELECTION																				60° C				
COPPER CABLE SIZE - From Control Box to Motor (in feet)																								
MOTOR					AWG												MCM							
VOLTS / HZ	HP	KW	FUSE		14	12	10	8	6	4	3	2	1	0	00	000	0000	250	300	350	400	500		
			STD	Dual Element																				
THREE PHASE																								
230 V 60 Hz	5	3.7	45	25	154	245	391	620	965	1538	1933	2442	3076	3883	4899	6184	7791	9198						
	7.5	5.5	60	40	-	174	277	438	682	1087	1367	1726	2174	2745	3463	4372	5508	6502	7806	9124				
	10	7.5	90	50	-	-	-	308	479	764	961	1213	1529	1930	2434	3073	3872	4571	5488	6415	7334	9125		
	15	11	125	80	-	-	-	216	337	537	675	852	1073	1355	1709	2158	2719	3210	3853	4504	5149	6407		
	20	15	175	110	-	-	-	-	251	400	503	636	801	1011	1275	1610	2028	2394	2874	3360	3842	4780		
	25	18.5	225	125	-	-	-	-	-	332	417	527	664	838	1057	1334	1681	1985	2383	2785	3184	3962		
460 V 60 Hz or 380 V 50 Hz	5	3.7	20	10	617	982	1566	2480	3859	6152	7734	9767												
	7.5	5.5	30	20	436	694	1107	1753	2728	4349	5467	6904	8698											
	10	7.5	45	25	307	488	778	1233	1918	3057	3844	4854	6115	7719	9738									
	15	11	70	40	-	343	546	865	1347	2147	2699	3408	4293	5419	6837	8631								
	20	15	90	50	-	-	408	646	1005	1601	2013	2543	3203	4043	5101	6439	8113	9578						
	25	18.5	110	60	-	-	-	535	833	1328	1669	2108	2655	3351	4228	5338	6725	7939	9531					
	30	22	125	70	-	-	-	479	745	1187	1492	1884	2374	2997	3781	4773	6013	7099	8522	9961				
40	30	150	100	-	-	-	-	546	870	1093	1381	1740	2196	2770	3497	4406	5202	6244	7299	8345				

Lengths only meet the US National Electrical Code ampacity requirements for individual conductors rated 60° C in free air or water, NOT in magnetic enclosures, conduit or direct buried. Refer to NEC Table 310.15(B)(17) for more information.

CABLE SELECTION																				75° C				
COPPER CABLE SIZE - From Control Box to Motor (in feet)																								
MOTOR					AWG												MCM							
VOLTS / HZ	HP	KW	FUSE		14	12	10	8	6	4	3	2	1	0	00	000	0000	250	300	350	400	500		
			STD	Dual Element																				
THREE PHASE																								
230 V 60 Hz	5	3.7	45	25	-	245	391	620	965	1538	1933	2442	3076	3883	4899	6184	7791	9198						
	7.5	5.5	60	40	-	-	277	438	682	1087	1367	1726	2174	2745	3463	4372	5508	6502	7806	9124				
	10	7.5	90	50	-	-	-	308	479	764	961	1213	1529	1930	2434	3073	3872	4571	5488	6415	7334	9125		
	15	11	125	80	-	-	-	-	337	537	675	852	1073	1355	1709	2158	2719	3210	3853	4504	5149	6407		
	20	15	175	110	-	-	-	-	-	400	503	636	801	1011	1275	1610	2028	2394	2874	3360	3842	4780		
	25	18.5	225	125	-	-	-	-	-	-	417	527	664	838	1057	1334	1681	1985	2383	2785	3184	3962		
460 V 60 Hz or 380 V 50 Hz	5	3.7	20	10	617	982	1566	2480	3859	6152	7734	9767												
	7.5	5.5	30	20	436	694	1107	1753	2728	4349	5467	6904	8698											
	10	7.5	45	25	-	488	778	1233	1918	3057	3844	4854	6115	7719	9738									
	15	11	70	40	-	-	546	865	1347	2147	2699	3408	4293	5419	6837	8631								
	20	15	90	50	-	-	-	646	1005	1601	2013	2543	3203	4043	5101	6439	8113	9578						
	25	18.5	110	60	-	-	-	535	833	1328	1669	2108	2655	3351	4228	5338	6725	7939	9531					
	30	22	125	70	-	-	-	-	745	1187	1492	1884	2374	2997	3781	4773	6013	7099	8522	9961				
40	30	150	100	-	-	-	-	-	870	1093	1381	1740	2196	2770	3497	4406	5202	6244	7299	8345				

Lengths only meet the US National Electrical Code ampacity requirements for individual conductors rated 75° C in free air or water, NOT in magnetic enclosures, conduit or direct buried. Refer to NEC Table 310.15(B)(17) for more information.

Cable Selection Guide

PENTEK® 6" Submersible Motors

CABLE SELECTION																					60° C			
COPPER CABLE SIZE - From Control Box to Motor (in feet)																								
MOTOR					AWG												MCM							
VOLTS	HP	KW	FUSE		14	12	10	8	6	4	3	2	1	0	00	000	0000	250	300	350	400	500		
			STD	Dual Element																				
THREE PHASE																								
230 V 60 Hz	5	3.7	45	25	-	-	391	620	965	1538	1933	2442	3076	3883	4899	6184	7791	9198						
	7.5	5.5	60	40	-	-	277	438	682	1087	1367	1726	2174	2745	3463	4372	5508	6502	7806	9124				
	10	7.5	90	50	-	-	-	-	479	764	961	1213	1529	1930	2434	3073	3872	4571	5488	6415	7334	9125		
	15	11	125	80	-	-	-	-	-	537	675	852	1073	1355	1709	2158	2719	3210	3853	4504	5149	6407		
	20	15	175	110	-	-	-	-	-	-	503	636	801	1011	1275	1610	2028	2394	2874	3360	3842	4780		
	25	18.5	225	125	-	-	-	-	-	-	-	527	664	838	1057	1334	1681	1985	2383	2785	3184	3962		
30	22	250	125	-	-	-	-	-	-	-	-	593	749	945	1193	1503	1775	2130	2490	2847	3543			
460 V 60 Hz or 380 V 50 Hz	5	3.7	20	10	617	982	1566	2480	3859	6152	7734	9767												
	7.5	5.5	30	20	436	694	1107	1753	2728	4349	5467	6904	8698											
	10	7.5	45	25	-	-	778	1233	1918	3057	3844	4854	6115	7719	9738									
	15	11	70	40	-	-	546	865	1347	2147	2699	3408	4293	5419	6837	8631								
	20	15	90	50	-	-	-	646	1005	1601	2013	2543	3203	4043	5101	6439	8113	9578						
	25	18.5	110	60	-	-	-	-	833	1328	1669	2108	2655	3351	4228	5338	6725	7939	9531					
30	22	125	70	-	-	-	-	745	1187	1492	1884	2374	2997	3781	4773	6013	7099	8522	9961					
40	30	150	100	-	-	-	-	-	-	1093	1381	1740	2196	2770	3497	4406	5202	6244	7299	8345				

Lengths meet the US National Electrical Code ampacity requirements for either individual conductors or jacketed rated 60° C cable and can be in conduit or direct buried. Flat molded and web/ribbon cable are considered jacketed cable. Refer to NEC Table 310.15(B)(16) for more information.

* = motors are 8" diameter

CABLE SELECTION																					75° C		
COPPER CABLE SIZE - From Control Box to Motor (in feet)																							
MOTOR					AWG												MCM						
VOLTS	HP	KW	FUSE		14	12	10	8	6	4	3	2	1	0	00	000	0000	250	300	350	400	500	
			STD	Dual Element																			
THREE PHASE																							
230 V 60 Hz	5	3.7	45	25	-	245	391	620	965	1538	1933	2442	3076	3883	4899	6184	7791	9198					
	7.5	5.5	60	40	-	-	277	438	682	1087	1367	1726	2174	2745	3463	4372	5508	6502	7806	9124			
	10	7.5	90	50	-	-	-	308	479	764	961	1213	1529	1930	2434	3073	3872	4571	5488	6415	7334	9125	
	15	11	125	80	-	-	-	-	337	537	675	852	1073	1355	1709	2158	2719	3210	3853	4504	5149	6407	
	20	15	175	110	-	-	-	-	400	503	636	801	1011	1275	1610	2028	2394	2874	3360	3842	4780		
	25	18.5	225	125	-	-	-	-	-	417	527	664	838	1057	1334	1681	1985	2383	2785	3184	3962		
30	22	250	125	-	-	-	-	-	-	471	593	749	945	1193	1503	1775	2130	2490	2847	3543			
460 V 60 Hz or 380 V 50 H	5	3.7	20	10	617	982	1566	2480	3859	6152	7734	9767											
	7.5	5.5	30	20	436	694	1107	1753	2728	4349	5467	6904	8698										
	10	7.5	45	25	-	488	778	1233	1918	3057	3844	4854	6115	7719	9738								
	15	11	70	40	-	-	546	865	1347	2147	2699	3408	4293	5419	6837	8631							
	20	15	90	50	-	-	-	646	1005	1601	2013	2543	3203	4043	5101	6439	8113	9578					
	25	18.5	110	60	-	-	-	535	833	1328	1669	2108	2655	3351	4228	5338	6725	7939	9531				
30	22	125	70	-	-	-	-	745	1187	1492	1884	2374	2997	3781	4773	6013	7099	8522	9961				
40	30	150	100	-	-	-	-	-	870	1093	1381	1740	2196	2770	3497	4406	5202	6244	7299	8345			

Lengths meet the US National Electrical Code ampacity requirements for either individual conductors or jacketed rated 75° C cable and can be in conduit or direct buried. Flat molded and web/ribbon cable are considered jacketed cable. Refer to NEC Table 310.15(B)(16) for more information.

LIMITED WARRANTY

STA-RITE® warrants to the original consumer purchaser (“Purchaser” or “You”) of the products listed below, that they will be free from defects in material and workmanship for the Warranty Period shown below.

PRODUCT	WARRANTY PERIOD
Water Systems Products: jet pumps, small centrifugal pumps, submersible pumps and related accessories	whichever occurs first: 12 months from date of original installation, or 18 months from date of manufacture
Pro-Source™ Composite Tanks	5 years from date of original installation
Pro-Source Steel Pressure Tanks	5 years from date of original installation
Pro-Source Epoxy-Lined Tanks	3 years from date of original installation
Sump/Sewage/Effluent Products	12 months from date of original installation, or 18 months from date of manufacture

Our warranty will not apply to any product that, in our sole judgement, has been subject to negligence, misapplication, improper installation, or improper maintenance. Without limiting the foregoing, operating a three phase motor with single phase power through a phase converter will void the warranty. Note also that three phase motors must be protected by three-leg, ambient compensated, extra-quick trip overload relays of the recommended size or the warranty is void.

Your only remedy, and STA-RITE's only duty, is that STA-RITE repair or replace defective products (at STA-RITE's choice). You must pay all labor and shipping charges associated with this warranty and must request warranty service through the installing dealer as soon as a problem is discovered. No request for service will be accepted if received after the Warranty Period has expired. This warranty is not transferable.

STA-RITE SHALL NOT BE LIABLE FOR ANY CONSEQUENTIAL, INCIDENTAL, OR CONTINGENT DAMAGES WHATSOEVER.

THE FOREGOING WARRANTIES ARE EXCLUSIVE AND IN LIEU OF ALL OTHER EXPRESS AND IMPLIED WARRANTIES, INCLUDING BUT NOT LIMITED TO THE IMPLIED WARRANTIES OF MERCHANTABILITY AND FITNESS FOR A PARTICULAR PURPOSE. THE FOREGOING WARRANTIES SHALL NOT EXTEND BEYOND THE DURATION EXPRESSLY PROVIDED HEREIN.

Some states do not allow the exclusion or limitation of incidental or consequential damages or limitations on the duration of an implied warranty, so the above limitations or exclusions may not apply to You. This warranty gives You specific legal rights and You may also have other rights which vary from state to state.

This warranty supersedes and replaces all previous warranty publications.

Retain original receipt for your records



293 WRIGHT STREET, DELAVAN, WI 53115 WWW.STA-RITE.COM
PH: 888-782-7483 ORDERS FAX: 800-426-9446

Because we are continuously improving our products and services, Pentair reserves the right to change specifications without prior notice.

© 2013 Pentair Ltd. All Rights Reserved.

S4500WS (05/01/13)