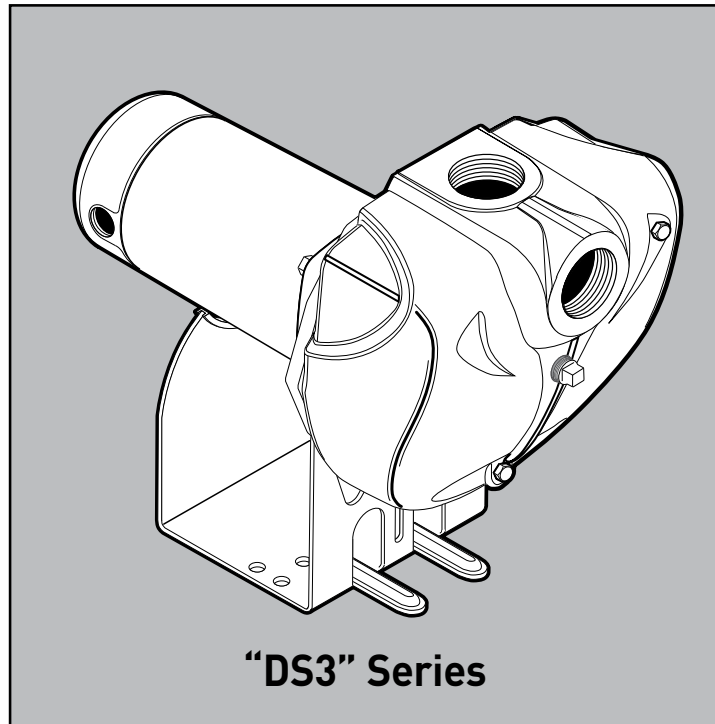

STA-RITE®

Installation/Operation/Parts
For further operating, installation,
or maintenance assistance:
Call 888-782-7483

READ AND FOLLOW SAFETY INSTRUCTIONS!

⚠️ This is the safety alert symbol. When you see this symbol on your pump or in this manual, look for one of the following signal words and be alert to the potential for personal injury.

⚠️ DANGER warns about hazards that **will** cause serious personal injury, death or major property damage if ignored.

⚠️ WARNING warns about hazards that **can** cause serious personal injury, death or major property damage if ignored.

⚠️ CAUTION warns about hazards that **will** or **can** cause minor personal injury or property damage if ignored.

The label **NOTICE** indicates special instructions which are important but not related to hazards.

Carefully read and follow all safety instructions in this manual and on pump.

Keep safety labels in good condition.

Replace missing or damaged safety labels.

California Proposition 65 Warning

⚠️ WARNING This product and related accessories contain chemicals known to the State of California to cause cancer, birth defects or other reproductive harm.

GENERAL SAFETY

	⚠️ WARNING
	<p>Hazardous pressure! Install pressure relief valve in discharge pipe.</p> <p>Release all pressure on system before working on any component.</p>

⚠️ CAUTION **Do not touch an operating motor.** Modern motors can operate at high temperatures. To avoid burns when servicing pump, allow it to cool for 20 minutes after shut-down before handling.

Pump is designed as a lawn sprinkler only. To avoid heat built-up, over pressure hazard and possible injury, do not use in a pressure tank (domestic water) system. Do not use as a booster pump; pressurized suction may cause pump body to explode.

Do not allow pump or piping system to freeze. Freezing can damage pump and pipe, may lead to injury from equipment failure and will void warranty.

Pump water only with this pump.

Periodically inspect pump and system components.

Wear safety glasses at all times when working on pumps.

Keep work area clean, uncluttered and properly lighted; store properly all unused tools and equipment.

Keep visitors at a safe distance from the work areas.

Make workshops childproof; use padlocks and master switches; remove starter keys.

ELECTRICAL SAFETY

⚠️ WARNING

<p>Hazardous voltage. Can shock, burn, or cause death.</p> <p>Ground pump before connecting to power supply.</p>

⚠️ Wire motor for correct voltage. See "Electrical" section of this manual and motor nameplate.

⚠️ Ground motor before connecting to power supply.

⚠️ Meet National Electrical Code, Canadian Electrical Code, and local codes for all wiring.

⚠️ Follow wiring instructions in this manual when connecting motor to power lines.

Thank you for purchasing a top quality, factory tested pump.

	Page
Safety.....	2
Warranty.....	3
Installation.....	4-5
Electrical.....	6
Operation.....	7
Maintenance.....	8-10
Troubleshooting.....	11
Repair Parts	12

Limited Warranty

STA-RITE warrants to the original consumer purchaser (“Purchaser” or “You”) of the products listed below, that they will be free from defects in material and workmanship for the Warranty Period shown below.

Product	Warranty Period
Water Systems Products — jet pumps, small centrifugal pumps, submersible pumps and related accessories	<i>whichever occurs first:</i> 12 months from date of original installation, or 18 months from date of manufacture
Pro-Source™ Composite Tanks	5 years from date of original installation
Pro-Source™ Steel Pressure Tanks	5 years from date of original installation
Pro-Source™ Epoxy-Lined Tanks	3 years from date of original installation
Sump/Sewage/Effluent Products	12 months from date of original installation, or 18 months from date of manufacture

Our warranty will not apply to any product that, in our sole judgement, has been subject to negligence, misapplication, improper installation, or improper maintenance. Without limiting the foregoing, operating a three phase motor with single phase power through a phase converter will void the warranty. Note also that three phase motors must be protected by three-leg, ambient compensated, extra-quick trip overload relays of the recommended size or the warranty is void.

Your only remedy, and STA-RITE’s only duty, is that STA-RITE repair or replace defective products (at STA-RITE’s choice). You must pay all labor and shipping charges associated with this warranty and must request warranty service through the installing dealer as soon as a problem is discovered. No request for service will be accepted if received after the Warranty Period has expired. This warranty is not transferable.

STA-RITE SHALL NOT BE LIABLE FOR ANY CONSEQUENTIAL, INCIDENTAL, OR CONTINGENT DAMAGES WHATSOEVER. THE FOREGOING WARRANTIES ARE EXCLUSIVE AND IN LIEU OF ALL OTHER EXPRESS AND IMPLIED WARRANTIES, INCLUDING BUT NOT LIMITED TO THE IMPLIED WARRANTIES OF MERCHANTABILITY AND FITNESS FOR A PARTICULAR PURPOSE. THE FOREGOING WARRANTIES SHALL NOT EXTEND BEYOND THE DURATION EXPRESSLY PROVIDED HEREIN.

Some states do not allow the exclusion or limitation of incidental or consequential damages or limitations on the duration of an implied warranty, so the above limitations or exclusions may not apply to You. This warranty gives You specific legal rights and You may also have other rights which vary from state to state.

This Limited Warranty is effective June 1, 2011 and replaces all undated warranties and warranties dated before June 1, 2011.

STA-RITE INDUSTRIES

293 Wright Street • Delavan, WI U.S.A. 53115

Phone: 1-888-782-7483 • Fax: 1-800-426-9446 • Web Site: sta-rite.com

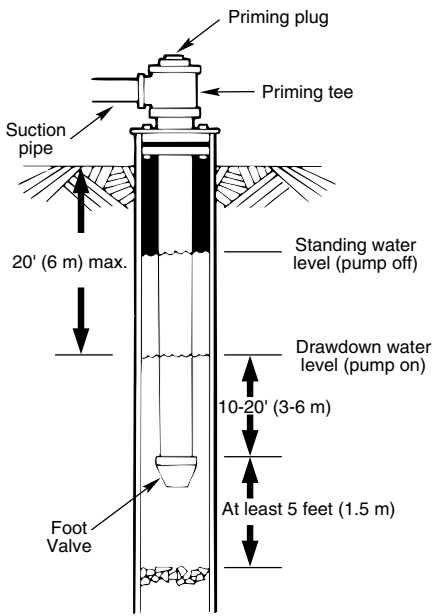

Figure 1: Cased/Dug Well Installation

BEFORE YOU INSTALL YOUR PUMP

NOTICE: Well must not be more than 20' depth to water.

1. Long runs and many fittings increase friction and reduce flow. Locate pump as close to well as possible: use as few elbows and fittings as possible.
2. Be sure well is clear of sand. Sand will plug the pump and void the warranty.
3. Protect pump and all piping from freezing. Freezing will split pipe, damage pump and void the warranty. Check locally for frost protection requirements (usually pipe must be 12" below frost line and pump must be insulated).
4. Be sure all pipes and foot valve are clean and in good shape.
5. No air pockets in suction pipe.
6. No leaks in suction pipe. Use PTFE pipe thread sealant tape to seal pipe joints.
7. Unions installed near pump and well will aid in servicing. Leave room use wrenches.
8. **⚠ WARNING** Pump body may explode if used as a booster pump. **DO NOT** use in a booster application.

WELL PIPE INSTALLATION

NOTICE: Use the installation method below which matches your well type.

CASED WELL INSTALLATION

1. Inspect foot valve to be sure it works freely. Inspect strainer to be sure it is clean.
2. Connect foot valve and strainer to the first length of suction pipe and lower pipe into well. Add sections of pipe as needed, using PTFE pipe thread sealant tape on male threads. Be sure that all suction pipe is leakproof or pump will lose prime and fail to pump. Install foot valve 10 to 20 feet below the lowest level to which water will drop while pump is operating (pumping water level). Your well driller can furnish this information.
3. To prevent sand and sediment from entering the pumping system, the foot valve/strainer should be at least 5 feet above the bottom of the well.
4. When the proper depth is reached, install a sanitary well seal over the pipe and in the well casing. Tighten the bolts to seal the casing.
5. When using a foot valve, a priming tee and plug as shown in Figure 1 are recommended.

DUG WELL INSTALLATION

Same as cased well installation.

DRIVEN POINT INSTALLATION

1. Connect the suction pipe to the drive point as illustrated in Figure 2. Keep horizontal pipe run as short as possible. Use PTFE pipe thread sealant tape on male pipe threads. Multiple well points may be necessary to provide sufficient water to pump.
2. Install a check valve in horizontal pipe. Flow arrow on check valve must point toward pump.

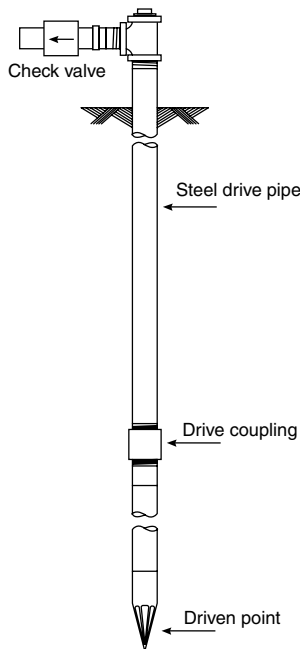

Figure 2: Driven Point Installation

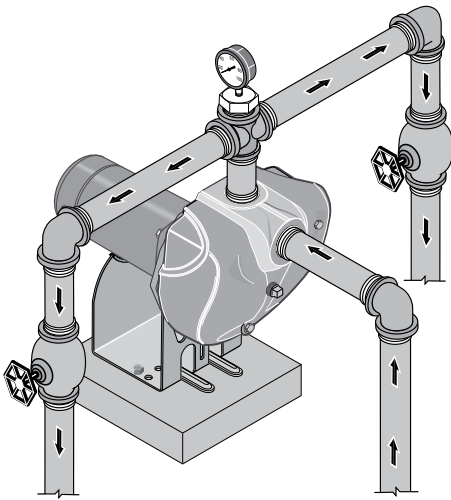

Figure 3: Multiple Discharge

HORIZONTAL PIPING FROM WELL TO PUMP

1. Never install a suction pipe that is smaller than the suction port of the pump.
2. To aid priming on well point installations, install a line check valve as shown in Figure 2. Be sure check valve flow arrow points toward pump.

DISCHARGE PIPE SIZES

1. If increasing discharge pipe size, install reducer in pump discharge port. Do not increase pipe size by stages.
2. When the pump is set away from the points of water use, the discharge pipe size should be increased to reduce pressure losses caused by friction.
 - Up to 100' run: Same size as pump discharge port.
 - 100' to 300' run: Increase one pipe size.
 - 300' to 600' run: Increase two pipe sizes.

LAWN SPRINKLING APPLICATION

This pump is designed for lawn sprinkling. It is designed to deliver plenty of water at full sprinkler pressure. It can pump from a pond, cistern or well points.

Pump discharge can be divided to supply two (2) or more sprinkler systems. A suggested multiple discharge to service is shown in Figure 3.

Do not use in a pressure tank or booster pump application.

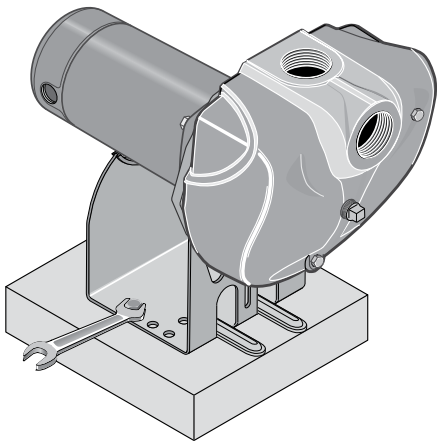

Figure 4: Bolt Pump Down

PUMP INSTALLATION

NOTICE: Use only PTFE pipe thread sealant tape for making all threaded connections to the pump itself. **Do not use pipe joint compounds on plastic pumps:** they can react with the plastic in the pump components. Make sure that all pipe joints in the suction pipe are air tight as well as water tight. *If the suction pipe can suck air, the pump will not be able to pull water from the well.*

1. Bolt pump to solid, level foundation.
2. Support all piping connected to the pump.
3. Wrap 1-1/2 to two layers of PTFE pipe thread sealant tape clockwise (as you face end of pipe) on all male threads being attached to pump.
4. Tighten joints hand tight plus 1-1/2 turns. Do not overtighten.

NOTICE: Install pump as close to well head as possible. Long piping runs and many fittings create friction and reduce flow.

NOTICE: For long horizontal pipe runs, install a priming tee between check valve and well head as shown in Figure 1. For driven point installations, install a check valve as shown in Figure 2. Be sure check valve flow arrow points **toward** pump.

Use schedule 80 or iron pipe. See "Well Pipe Installation" for more information.

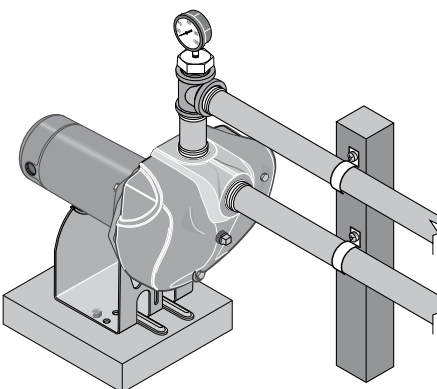

Figure 5: Independently Support All Piping Attached to Pump

Connection diagram for dual voltage, single-phase motors. Your dual-voltage motor's terminal board (under the motor end cover) will match one of the diagrams below. Follow that diagram if necessary to convert motor to 115 Volt power.

Connect power supply wires to L1 and L2. For 3-phase motors, or if motor does not match these pictures, follow the connection diagram on the motor nameplate.

MOTOR SWITCH SETTINGS

Dual-voltage motors (motors that can operate at either 115 or 230 volts), are set at the factory to 230 volts. Do not change motor voltage setting if line voltage is 230 volts, or if you have a single voltage motor.

NOTICE: Never wire a 115 volt motor to a 230 volt line.

REMOVE MOTOR END COVER

If you have a dual-voltage motor, and will connect it to 115 volts, follow the procedure below.

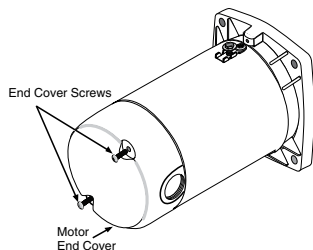

Figure 6: Removing Motor End Cover

You will need to remove the motor end cover to change the voltage setting.

Your motor terminal board (located under the motor end cover) should look like one of those below.

PLUG TYPE VOLTAGE SELECTOR

To change to 115 volts:

1. Make sure power is off.
2. Pull the plug straight up.
3. Move and attach the plug at the 115 volt position. The plug will now cover 2 metal tabs. The arrow on the plug will point to 115V.
4. Attach the power lead wires to the power lead terminals. Make sure the wires are secure.

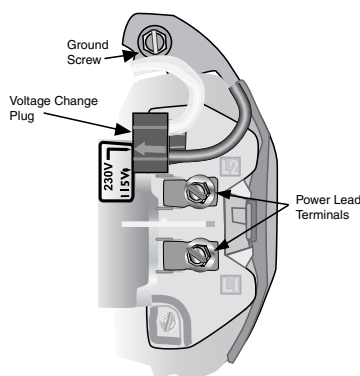

Figure 7: Voltage set to 230 volts, Plug Type

5. Attach the ground wire to the green ground screw

6. Reinstall the Motor end cover

Go to Wiring Connections below.

DIAL TYPE VOLTAGE SELECTOR

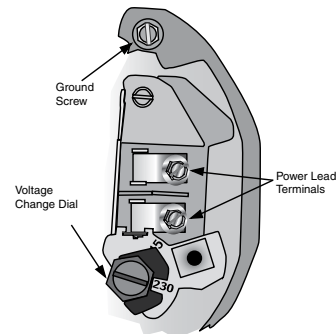

Figure 8: Voltage set to 230 volts, Dial Type

To change to 115 volts:

1. Make sure power is off.
 2. Turn the dial counter-clockwise until 115 shows in the dial window.
 3. Attach the power lead wires to the power lead terminals. Make sure the wires are secure.
 4. Attach the ground wire to the green ground screw
 5. Reinstall the Motor end cover
- Go to Wiring Connections below.

⚠ WARNING Hazardous voltage. Can shock, burn, or cause death. Disconnect power to motor before working on pump or motor. Ground motor before connecting to power supply.

WIRING CONNECTIONS

⚠ Ground motor before connecting to electrical power supply. Failure to ground motor can cause severe or fatal electrical shock hazard.

⚠ Do not ground to a gas supply line.

⚠ To avoid dangerous or fatal electrical shock, turn OFF power to motor before working on electrical connections.

⚠ Supply voltage must be within $\pm 10\%$ of nameplate voltage. Incorrect voltage can cause fire or damage motor and voids warranty. If in doubt consult a licensed electrician.

⚠ Use wire size specified in Wiring Chart, Page 7. If possible, connect pump to a separate branch circuit with no other appliances on it.

⚠ Wire motor according to diagram on motor nameplate. If nameplate diagram differs from diagrams above, follow nameplate diagram.

1. Install, ground, wire and maintain this pump in accordance with electrical code requirements. Consult your local building inspector for information about codes.

Wiring Chart – Recommended Wire and Fuse Sizes

Model	HP	Max. Load Amp	Volts/Hz Phase	Branch Fuse Rating Amp	DISTANCE IN FEET(METERS) FROM MOTOR TO SUPPLY			
					0 - 50 (0 - 15)	51 - 100 (31 - 61)	101 - 200 (62 - 91)	201 - 300 (92 - 122)
					AWG WIRE SIZE (mm ²)			
DS3HE-01	1	14.8/7.4	115/230/60/1	20/15	12/14 (3/2)	12/14 (3/2)	8/14 (8.4/2)	6/14 (14/2)
DS3HE3-01	1	3.6/1.8	230/460/60/3	15/15	14/14 (2/2)	14/14 (2/2)	14/14 (2/2)	14/14 (2/2)
DS3HF-01	1-1/2	20/10	115/230/60/1	25/15	10/14 (5.5/2)	10/14 (5.5/2)	8/14 (8.4/2)	6/12 (14/3)
DS3HF3-01	1-1/2	4.7/2.35	230/460/60/3	15/15	14/14 (2/2)	14/14 (2/2)	14/14 (2/2)	14/14 (2/2)
DS3HG-01	2	24/12	115/230/60/1	30/15	12/14 (3/2)	10/14 (5.5/2)	6/14 (14/2)	6/12 (14/3)
DS3HG3-01	2	5.8/2.9	230/460/60/3	15/15	14/14 (2/2)	14/14 (2/2)	14/14 (2/2)	14/14 (2/2)
DS3HHG-01	2-1/2	26/12	115/230/60/1	35/15	12/14 (3/2)	10/14 (5.5/2)	6/14 (14/2)	6/8 (14/8.4)
DS3HHG3-01	2-1/2	6.9/3.45	230/460/60/3	15/15	14/14 (2/2)	14/14 (2/2)	14/14 (2/2)	14/14 (2/2)

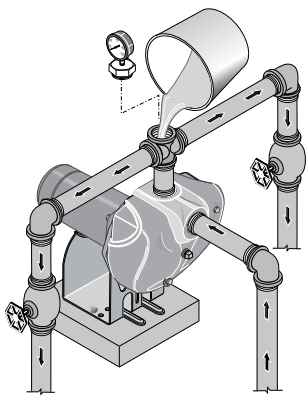

Figure 9: Remove Priming Plug and Fill Pump Before Starting

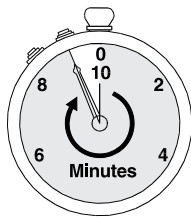

Figure 10: Run Ten Minutes or Less



Figure 11: Do Not Run Pump with Discharge Shut-off

2. Provide a correctly fused disconnect switch for protection while working on motor. Consult local or national electrical codes for switch requirements.
 3. Disconnect power before servicing motor or pump. If the disconnect switch is out of sight of pump, lock it open and tag it to prevent unexpected power application.
 4. Ground the pump permanently using a wire of the same size as that specified in wiring chart, below. Make ground connection to green grounding terminal under motor canopy marked GRD. or ⏏ .
 5. Connect ground wire to a grounded lead in the service panel or to a metal underground water pipe or well casing at least 10 feet long. Do not connect to plastic pipe or insulated fittings.
 6. Protect current carrying and grounding conductors from cuts, grease, heat, oil, and chemicals.
 7. Connect current carrying conductors to terminals L₁ and L₂ under motor canopy. When replacing motor, check wiring diagram on motor nameplate against Figure 6. If the motor wiring diagram does not match either diagram in Figure 6, follow the diagram on the motor.
- IMPORTANT:** 115/230 Volt single phase models are shipped from factory with motor wired for 230 volts. If power supply is 115 volts, remove motor canopy and reconnect motor as shown in Figure 6. Do not try to run motor as received on 115 volt current.
8. Motor has automatic internal thermal overload protection. If motor has stopped for unknown reasons, thermal overload may restart it unexpectedly, which could cause injury or property damage. Disconnect power before servicing motor.
 9. If this procedure or the wiring diagrams are confusing, consult a licensed electrician.

PRIMING THE PUMP

NOTICE: ‘Priming’ refers to the pump expelling all air in the system and beginning to move water from its source out into the system. It does not refer only to pouring water into the pump (although pouring water in is usually the first step).

NOTICE: NEVER run pump dry. Running pump without water in it will damage seals and can melt impeller and diffuser. To prevent damage, **fill pump with water before starting.**

1. Remove priming plug (Figure 9).
2. Make sure suction and discharge valves and any hoses on discharge side of pump are open.

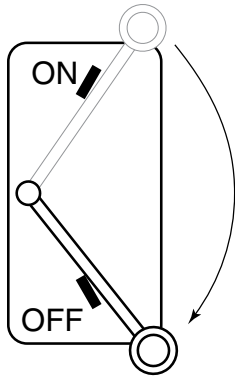

Figure 12: Disconnect Power

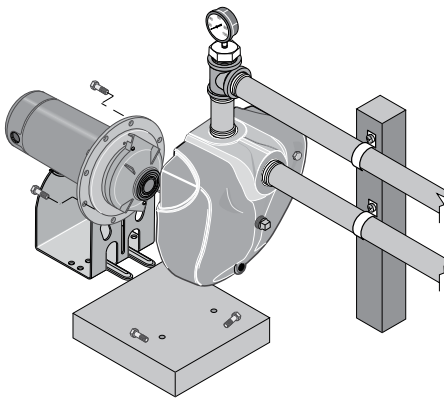

Figure 13: Slide Motor Back

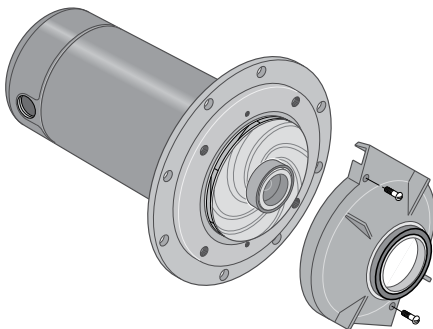

Figure 14: Remove Diffuser

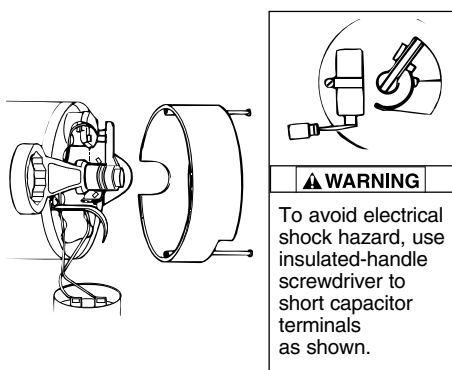

Figure 15: Hold Shaft

3. Fill pump and suction pipe with water.
4. Replace priming plug, using PTFE pipe thread sealant tape on thread; tighten plug.
NOTICE: If a priming tee and plug have been provided for a long horizontal run, be sure to fill suction pipe through this tee and replace plug. (Don't forget to PTFE pipe thread sealant tape the plug.)
5. Start pump: water should be produced in 10 minutes or less, the time depending on depth to water (not more than 20') and length of horizontal run (10' of horizontal suction pipe = 1' of vertical lift due to friction losses in the pipe).
If no water is produced within 10 minutes, stop pump, release all pressure, remove priming plug, refill and try again.

⚠ WARNING Hazardous pressure and risk of explosion and scalding. If pump is run continuously at no flow (that is, with discharge shut off or without priming), water may boil in pump and piping system. Under steam pressure, pipes may rupture, blow off of fittings or blow out of pump ports and scald anyone near.

To prevent explosion, do the following:

- A. Be sure discharge (valve, pistol grip hose nozzle, etc.) is open whenever pump is running.
- B. If pump fails to produce water when attempting to prime, release all pressure, drain pump and refill with cold water after every two attempts.
- C. When priming, monitor pump and piping temperature. If pump or piping begin to feel warm to the touch, shut off pump and allow system to cool off. Release all pressure in system and refill pump and piping with cold water.

Pump and piping need not be disconnected to repair or replace motor or seal (see Figure 13). If motor is replaced, replace the shaft seal (Key No. 5, Page 12). Keep one on hand for future use.

Be sure to prime pump before starting.

NOTICE: Check motor label for lubrication instructions. The mechanical shaft seal in the pump is water lubricated and self-adjusting.

NOTICE: Drain pump when disconnecting from service or when it might freeze.

PUMP DISASSEMBLY

1. Disconnect power to motor.
NOTICE: Mark wires for correct assembly.
2. Remove capscrews holding seal plate to pump body. Motor assembly and seal plate can now be pulled away from pump body (Figure 13). CAREFULLY remove gasket.

CLEANING/REPLACING IMPELLER

NOTICE: First, follow instructions under "Pump Disassembly".

1. Remove screws fastening diffuser to seal plate; remove diffuser (see Figure 14). Exposed impeller can now be cleaned.
2. If impeller must be replaced, loosen two machine screws and remove motor canopy (see Figure 15).
3. **⚠ WARNING** Capacitor voltage may be hazardous. To discharge capacitor, hold insulated handle screwdriver **BY THE HANDLE** and short capacitor terminals together (see Figure 15). Do not touch metal screwdriver blade or capacitor terminals. If in doubt, consult a qualified electrician.

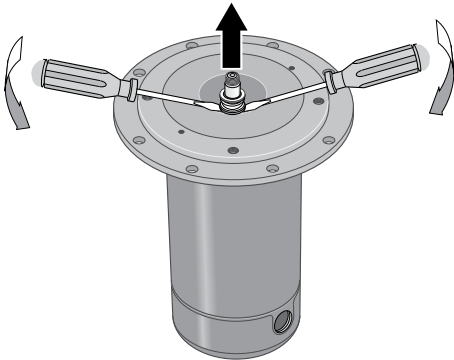

Figure 16: Remove Seal plate

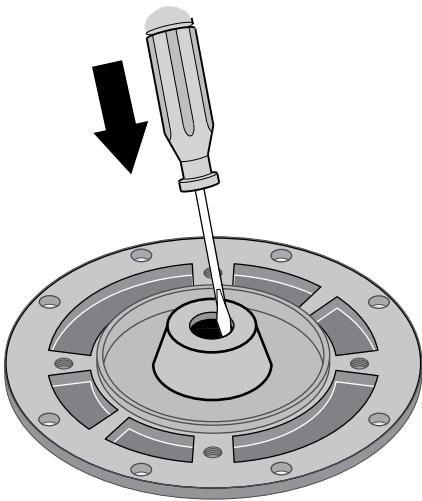

Figure 17: Tap Out Seal

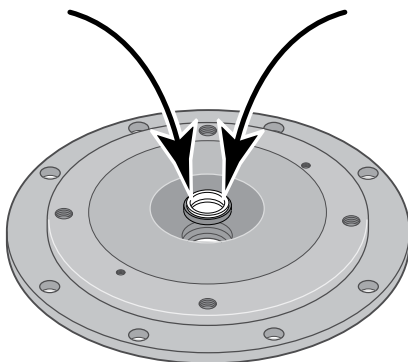

Figure 18: Press in New Seal

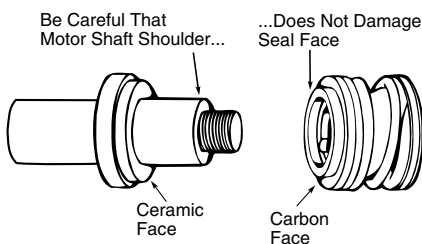

Figure 19: Protect Seal Faces

4. Unscrew capacitor clamp and remove capacitor. Do not disconnect capacitor wires to motor.
5. Slide 7/16" open end wrench in behind spring loaded switch on motor end of shaft; hold motor shaft with wrench on shaft flats and unscrew impeller screw (if used) by turning clockwise (**left hand thread**) when looking into eye of impeller.
6. Unscrew impeller while holding shaft by turning **counterclockwise** while looking into eye of impeller.
7. To reinstall, reverse steps 1 through 6.
8. See directions under "Pump Reassembly," Page 10.

REMOVING OLD SEAL

1. Follow instructions under "Pump Disassembly".
2. Follow steps 2 through 5 under "Cleaning/Replacing Impeller".
3. Remove rotating half of seal by placing two screwdrivers under seal ring and **carefully** prying up (Figure 16).
4. Remove nuts from studs holding seal plate to motor. Carefully slide seal plate off of shaft.
NOTICE: Be sure you do not scratch or mar shaft; if shaft is marred, it must be dressed smooth with fine emery or crocus cloth before installing new seal. **DO NOT** reduce shaft diameter!
5. Place seal plate half face down on flat surface and tap out stationary half of seal (see Figure 17).

INSTALLING NEW SEAL

1. Clean seal cavity in seal plate.
2. Wet outer edge of Rubber Cup on ceramic seat with liquid soap. Be sparing!
3. Put clean cardboard washer on seal face. With thumb pressure, press ceramic seal half firmly and squarely into seal cavity (See Figure 18). Polished face of ceramic seat is up. If seal will not seat correctly, remove, placing seal face up on bench. Reclean cavity. Seal should now seat correctly.
4. If seal does not seat correctly after recleaning cavity, place a cardboard washer over polished seal face and **carefully** press into place using a piece of standard 3/4" pipe as a press.
NOTICE: Be sure you do not scratch seal face.
5. Dispose of cardboard washer and recheck seal face to be sure it is free of dirt, foreign particles, scratches and grease.
6. Inspect shaft to be sure it is free of nicks and scratches.
7. Reassemble pump body half to motor flange. **BE SURE** it is right side up.
8. Apply liquid soap sparingly (one drop is sufficient) to inside diameter of rotating seal member.
9. Slide rotating seal member (carbon face first) onto shaft until rubber drive ring hits shaft shoulder.

NOTICE: Be sure not to nick or scratch carbon face of seal when passing it over threaded shaft end or shaft shoulder. The carbon surface must remain clean or short seal life will result.

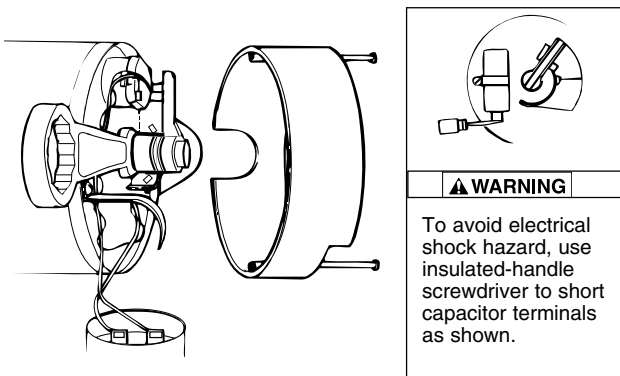

Figure 20: Hold Shaft

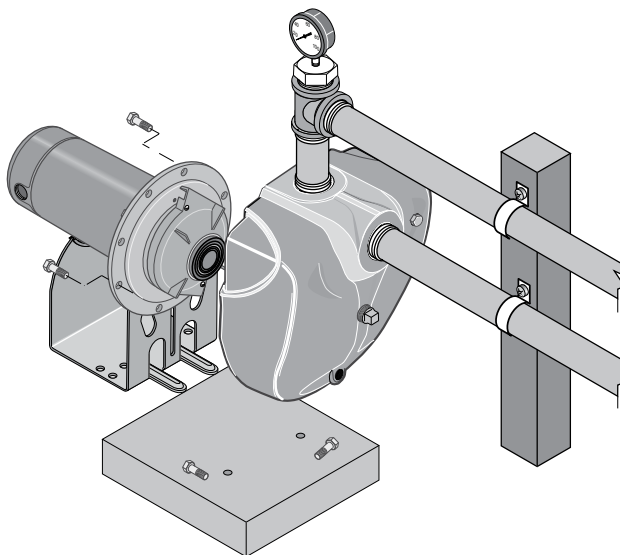

Figure 21: Assemble Pump

10. Hold motor shaft with 7/16" open end wrench on shaft flats and screw impeller onto shaft. **Be sure you do not touch capacitor terminals with body or any metal object.** Tightening impeller will automatically locate seal in correct position.
11. Replace impeller screw (if used) by turning counterclockwise (left-hand thread) into end of shaft.
12. Remount diffuser on seal plate with two screws.
13. Follow instructions under "Pump Reassembly".

PUMP REASSEMBLY

1. Clean gasket surfaces on pump body and seal plate; install new gasket.
2. Slide motor/seal plate assembly into pump body. Secure with capscrews.
3. Replace base mounting bolts.
4. Replace motor wiring; close draincock.
5. Prime pump according to instructions. See "Operation."
6. Check for leaks.

Troubleshooting

SYMPTOM	POSSIBLE CAUSE(S)	CORRECTIVE ACTION
Motor will not run	Disconnect switch is off Fuse is blown Starting switch is defective Wires at motor are loose, disconnected, or wired incorrectly	Be sure switch is on Replace fuse Replace starting switch Refer to instructions on wiring. Check and tighten all wiring. ⚠ WARNING Capacitor voltage may be hazardous. To discharge capacitor, hold insulated handle screwdriver BY THE HANDLE and short capacitor terminals together. Do not touch metal screwdriver blade or capacitor terminals. If in doubt, consult a qualified electrician.
Motor runs hot and overload kicks off	Motor is wired incorrectly Voltage is too low	Refer to instructions on wiring Check with power company. Install heavier wiring if wire size is too small (See Electrical, Page 6)
Motor runs but no water is delivered *(Notice: Check prime before looking for other causes. Unscrew priming plug and see if there is water in priming hole.)	*Pump in new installation did not pick up prime through: <ol style="list-style-type: none"> 1. Improper priming 2. Air leaks 3. Leaking foot valve *Pump has lost prime through: <ol style="list-style-type: none"> 1. Air leaks 2. Water level below suction of pump Impeller is plugged Check valve or foot valve is stuck in closed position Pipes are frozen Foot valve and/or strainer are buried in sand or mud	In new installation: <ol style="list-style-type: none"> 1. Re-prime according to instructions 2. Check all connections on suction line 3. Replace foot valve In installation already in use: <ol style="list-style-type: none"> 1. Check all connections on suction line and shaft seal 2. Lower suction line into water and re-prime. If receding water level in well exceeds suction lift, a deep well pump is needed Clean impeller; see Maintenance Replace check valve or foot valve Thaw pipes. Bury pipes below frost line. Heat pit or pump house. Raise foot valve and/or strainer above well bottom
Pump does not deliver water to full capacity (Also check point 3 immediately above)	Water level in well is lower than estimated Steel piping (if used) is corroded or limed, causing excess friction Offset piping is too small in size	A deep well jet pump may be needed (over 20 ft. to water) Replace with plastic pipe where possible, otherwise with new steel pipe Use larger offset piping

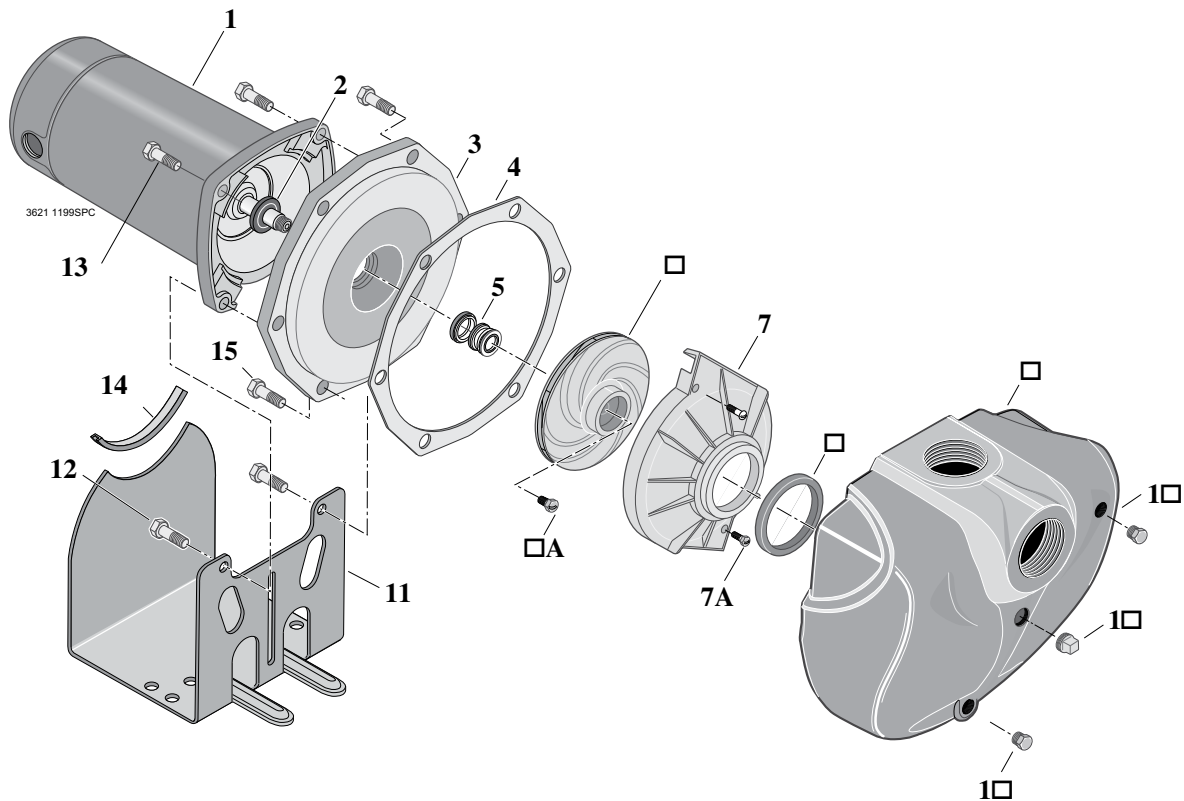

Key No.	Part Description	Qty.	MODEL NUMBER			
			DS3HE-01 DS3HE3-01 1 HP	DS3HF-01 DS3HF3-01 1-1/2 HP	DS3HG-01 DS3HG3-01 2 HP	DS3HHG-01 DS3HHG3-01 2-1/2 HP
1	Motor, 115/230V, 1 Phase	1	J218-596PKG	J218-601PKG	J218-883APKG	J218-628A
1	Motor, 230/460V, 3 Phase	1	AP100EL	AP100FL	AP100GL	AP100G5L
2	Water Slinger	1	17351-0009	17351-0009	17351-0009	17351-0009
3	Seal Plate	1	C3-155	C3-155	C3-117	C3-117
4	Gasket - Seal Plate	1	C20-86	C20-86	C20-87	C20-87
5	Shaft Seal	1	U109-6A	U109-6A	U109-6A	U109-6A
6	Impeller (1 Phase)	1	C105-92PKB	C105-92PC	C105-214PDA	C105-214PA
6	Impeller (3 Phase)	1	C105-92PKBA	C105-92PCA	C105-214PDA	C105-214PA
6A	Impeller Screw (1 Phase)	1	—	—	C30-14SS	C30-14SS
6A	Impeller Screw (3 Phase)	1	C30-14SS	C30-14SS	C30-14SS	C30-14SS
7	Diffuser	1	C101-276P	C101-276P	C101-182	C101-182
7A	Screw 10-24 x1" Lg Hex Head	2	U30-696SS	U30-696SS	—	—
7A	Machine screw 8-32x7/8" Lg.	2	—	—	U30-53SS	U30-53SS
8	Diffuser Ring	1	C21-10	C21-10	C21-2	C21-2
9	Pump Body Assembly	1	C76-67E	C76-67E	C76-68E	C76-68E
10	Plug 1/4" NPT Hex Head	2	U78-941ZPV	U78-941ZPV	U78-941ZPV	U78-941ZPV
11	Base	1	C4-82	C4-82	C4-82	C4-82A*
12	3/8-16x1-1/4" Lower Capscrew	2	U30-75ZP	U30-75ZP	U30-75ZP	U30-75ZP
13	3/8-16x1" Upper Capscrew	2	U30-74ZP	U30-74ZP	U30-74ZP	U30-99SS
14	Motor Pad	1	C35-5	C35-5	C35-5	C35-5
15	Capscrew 3/8-16x3/4" Lg	6	U30-72ZP	U30-72ZP	—	—
15	Capscrew 5/16-18x3/4" Lg.	8	—	—	U30-60ZP	U30-60ZP
16	Pipe Plug 3/4" NPT - Sq. Hd.	1	U78-60ZPS	U78-60ZPS	U78-60ZPS	U78-60ZPS
•	Lockwasher 3/8"	2	U43-12ZP	U43-12ZP	U43-12ZP	U43-12ZP
•	Nut, 3/16"-18 Hex Head	2	U36-37ZP	U36-37ZP	U36-37ZP	U36-37ZP

• Not illustrated.

* Model DS3HHG3-01 uses Base C4-82.