

# Royal® Flushometer

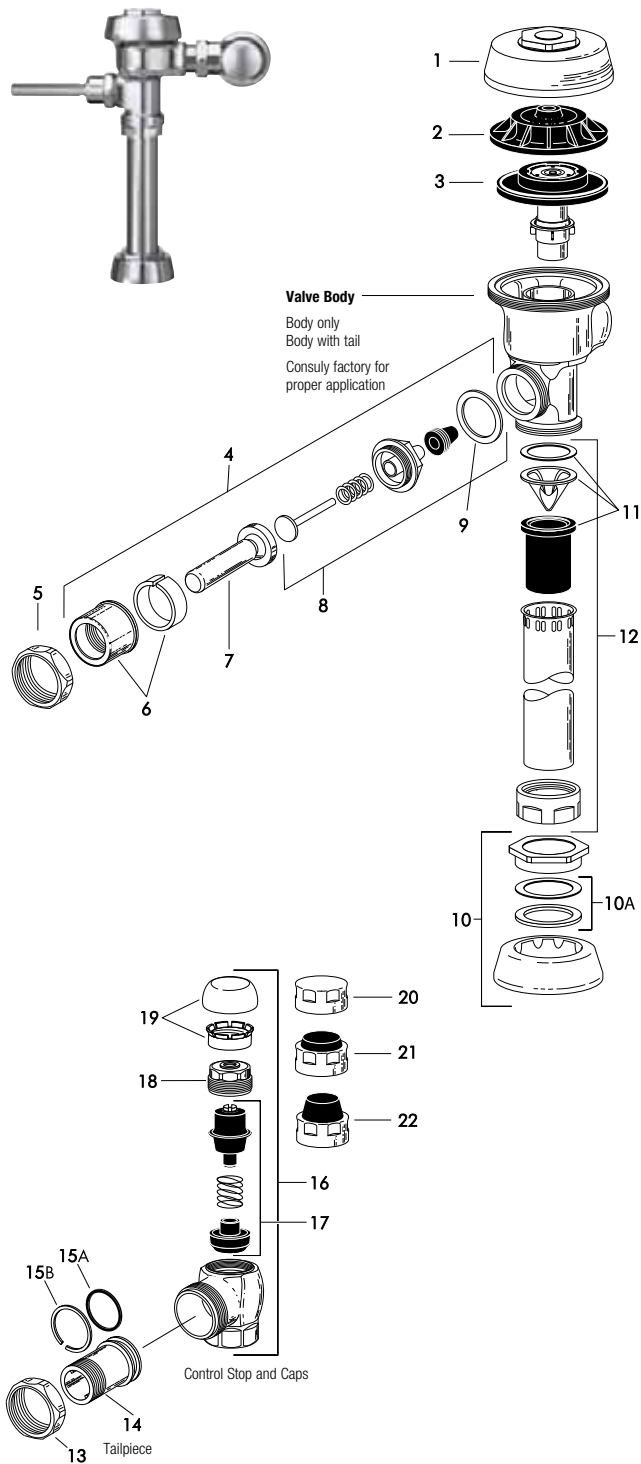

### TAILPIECES, CONTROL STOPS AND FLUSH CONNECTIONS

For additional information on tailpieces, control stops and flush connections see Showerheads, Parts and Accessories Tab.

### PARTS LIST

Item No.	Code No.	Part No.	Description
1.	0301172	A-72	CP Cover
	0301435PKA-72-HE		CP High Efficiency Cover
2.	0301168	A-71	Inside Cover
3.	—		Dual-Filtered Bypass Diaphragm Assembly (refer to table and diagram on following page)
4.	0302390	B-73-A	CP ADA-Compliant Triple Seal Handle Assembly
5.	0301082	A-6	CP Handle Coupling
6.	0302109	B-7-A	CP Socket Assembly
7.	0302389	B-74-A	CP ADA-Compliant Handle
8.	3302306	B-51-A	Triple Seal Handle Repair Kit
9.	5301139	A-31	Handle Gasket – 48 per package
10.	0306125	F-5-AW	3/4" (19 mm) CP Spud Coupling Assembly
	0306140	F-5-AU	1-1/4" (32 mm) CP Spud Coupling Assembly
	0306146	F-5-AT	1-1/2" (38 mm) CP Spud Coupling Assembly
10A.	<b>SEE SLIP JOINT GASKETS AND RINGS TABLE BELOW</b>		
11.	3323182	V-651-A	High Back Pressure Vacuum Breaker Repair Kit
12.	3393004	V-600-AA	3/4" (19 mm) x 9" (228 mm) CP Vacuum Breaker
	3393006	V-600-AA	1-1/4" (32 mm) x 9" (228 mm) CP Vacuum Breaker
	3393007	V-600-AA	1-1/2" (38 mm) x 9" (228 mm) CP Vacuum Breaker
13.	0308676	H-550	CP Stop Coupling
14.	0308801	H-551-A	CP Adjustable Tailpiece 2-1/16" (52 mm long) Standard Length*
15A.	5308696	H-553	O-ring – 24 per package
15B.	5308381	H-552	Locking Ring – 12 per package
16.	3308386	H-700-A	1" (25 mm) CP Bak-Chek® Screwdriver Stop
	3308384	H-700-A	3/4" (19 mm) CP Bak-Chek® Screwdriver Stop
17.	3308853	H-541-ASD	Control Stop Repair Kit †
	3308856	H-543-ASD	Control Stop Repair Kit †
18.	0308612	H-622	CP Bonnet †
	0308843	H-577	CP Bonnet † – <b>DISCONTINUED</b>
19.	3308772	H-1010-A	Vandal Resistant Control Stop Cap Assembly †
	3308790	H-1009-A	Vandal Resistant Control Stop Cap Assembly † H-600 3/4" Stop only
20.	0308738	H-573	Control Stop Cap CP †
	0308848	H-582	Control Stop Cap CP †
21.	3308866	H-574	Control Stop Cap with Bumper † (-YO Variation)
22.	3308867	H-576	Control Stop Cap with Extended Bumper † (-YG Variation)

\* See pages 102-103 for additional lengths

† For use with 1" and 3/4" H-700-A and 1" H-600-A Bak-Chek® screwdriver control stop

‡ For use with 3/4" H-600-A Bak-Chek® screwdriver control stop

Sloan products are also available in satin, brushed nickel, chrome, gold and polished brass finishes – contact factory for part numbers.

### ITEM 10A. SLIP JOINT GASKETS AND RINGS

Size	Code No.	Part No.	Description
1-1/2"	5306058	F-3	Red Friction Ring
	5322001	VBF-5	Black Slip Joint Gasket
	0319086/5319086	S-30	Flexible Seat
	0319079	S-21	Rigid Seat (rubber over brass)
1-1/2" x 1-1/4"	0396062	F-105	Slip Joint Gasket – Rigid
1-1/4"	5306057	F-3	Red Friction Ring
	5322176	VBF-5	Black Slip Joint Gasket
	0307052/5307052	G-21	Rigid Seat (rubber over brass)
1"	5306056	F-3	Red Friction Ring
	5306115	F-5	Black Slip Joint Gasket
3/4"	5306055	F-3	Red Friction Ring
	5306113	F-5	Black Slip Joint Gasket

# Royal® Flushometer

## DUAL-FILTERED DIAPHRAGM ASSEMBLY

Available in diaphragm only and Royal® Performance™ Kits.

Royal® Performance™ Kit includes dual-filtered diaphragm assembly (item 3), handle repair kit with triple seal packing (item 8), high back pressure vacuum breaker repair kit (item 11), and one tailpiece O-ring (item 15A). DIAPHRAGM ONLY KIT contains "drop-in" dual-filtered diaphragm assembly (item 3) ONLY.

The dual-filtered diaphragm can be used in Royal®, Regal®, and similar diaphragm-style valve bodies. For use in Sloan valve bodies with a bell-shaped cover (manufactured before 1964), replace the bottom filter ring in these kits with a blue A-108 filter ring (not shown Sloan Code No. **5301283**).

*NOTE: In January 1998, the Royal® diaphragm design was upgraded to a preassembled unit with two (2) plastic filtering rings attached to the rubber diaphragm (one on top and one on bottom). If the flushometer you are servicing has our older, segmented diaphragm with brass by-pass hole, refer to our Regal section for additional troubleshooting information.*

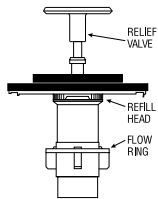
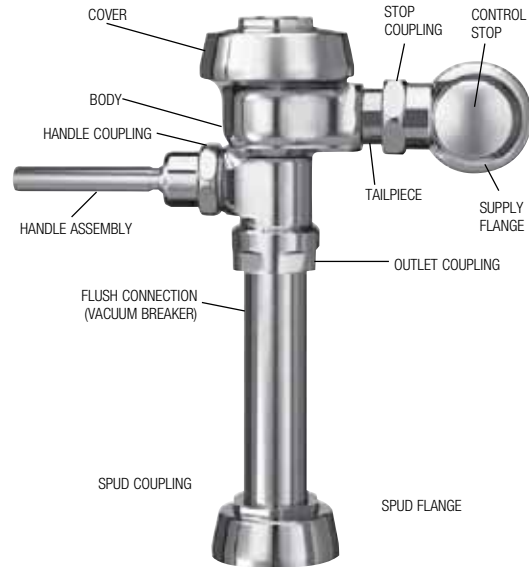

The colors of the relief valve and the refill head plus the shape of flow ring identify the flush volume of a DUAL-FILTERED DIAPHRAGM ASSEMBLY.

## ROYAL® PERFORMANCE KIT

Code No.	Part No.	Description	Relief Valve†	Refill Head*	Flow Ring
<b>3301070</b>	A-1101-A	Low Consumption Water Closets-1.6 gpf (6.0 Lpf)**	Green	Gray	Smooth
<b>3301071</b>	A-1102-A	Water Saver Water Closets-3.5 gpf (13.2 Lpf)**	White	Gray	Smooth
<b>3301072</b>	A-1103-A	9 Liter European Water Closets-2.4 gpf (9.0 Lpf)	Blue	Gray	Smooth
<b>3301073</b>	A-1106-A	Wash Down Urinals-0.5 gpf (1.9 Lpf)	Green	Black	Smooth
<b>3301074</b>	A-1107-A	Low Consumption Urinals-1.0 gpf (3.8 Lpf)**	Green	Black	Slotted
<b>3301075</b>	A-1108-A	Water Saver Urinals-1.5 gpf (5.7 Lpf)**	Black	Black	Smooth

\*Closet refill heads (gray) have larger slots than urinal refill heads (black).

## DIAPHRAGM ONLY KIT

Code No.	Part No.	Description	Relief Valve†	Refill Head*	Flow Ring
<b>3301502</b>	A-1041-A	Low Consumption Water Closets-1.6 gpf (6.0 Lpf)**	Green	Gray	Smooth
<b>3301501</b>	A-1038-A	Water Saver Water Closets-3.5 gpf (13.2 Lpf)**	White	Gray	Smooth
<b>3301505</b>	A-1044-A	9 Liter European Water Closets-2.4 gpf (9.0 Lpf)	Blue	Gray	Smooth
<b>3301504</b>	A-1043-A	Wash Down Urinals-0.5 gpf (1.9 Lpf)	Green	Black	Smooth
<b>3301503</b>	A-1042-A	Low Consumption Urinals-1.0 gpf (3.8 Lpf)**	Green	Black	Slotted
<b>3301500</b>	A-1037-A	Water Saver Urinals-1.5 gpf (5.7 Lpf)**	Black	Black	Smooth
<b>3301506</b>	A-1045-A	High-Efficiency Water Closets-1.28 gpf (4.8 Lpf)	Blue	Gray	Smooth
<b>3301142</b>	A-1047-A	High-Efficiency Urinals-0.25 gpf (1.0 Lpf) with White Inserts	White	HEU Black	Smooth
<b>3301143</b>	A-1050-A	High-Efficiency Urinals-0.125 gpf (0.5 Lpf) with Green Inserts	Blue	HEU Black	Smooth

† Consult factory for availability of replacement plastic relief valves (green, black, blue, and white) and brass relief valves.

NOTE: For older water closets that require 4.5 gpf (17.0 Lpf), choose kits A-1102-A or A-1038-A, but remove the flow ring before use. For blowout-style urinals that require 3.5 gpf (13.2 Lpf), choose kits A-1102-A or A-1038-A. For service sinks that require 6.5 gpf (24.6 Lpf), order A-36-A diaphragm repair kit (not shown Sloan Code No. **3301036**) and remove the flow ring before use. Regulations for low consumption fixtures prohibit the use of higher flush volumes.

\*Closet refill heads (gray) have larger slots than urinal refill heads (black).

\*\* Water Saver (3.5 gpf closet and 1.5 gpf urinal) and Low Consumption (1.6 gpf closet and 1.0 gpf urinal) fixtures must use matching gpf (Lpf) diaphragm kits; using a smaller gpf (Lpf) kit in fixtures not intended for less volume will result in inadequate dilution in urinals and improper evacuation in closets.

## Royal® Flushometer

### TROUBLESHOOTING GUIDE

**ATTENTION INSTALLERS:** *With the exception of the control stop inlet, DO NOT USE pipe sealant or plumbing grease on any valve component or coupling! To protect the chrome or special finish of Sloan flushometers, DO NOT USE toothed tools to install or service these valves. Use our A-50 Super-Wrench or other smooth-jawed wrench to secure couplings. Regulations for low consumption fixtures (1.6 gpf/6.0 Lpf closets and 1.0 gpf/3.8 Lpf urinals) prohibit use of higher flush volumes.*

#### 1. Flushometer does not function (no flush).

- A. Control stop or main supply valve is closed. Open control stop or main supply valve.
- B. Handle assembly is damaged. Replace B-73-A handle or repair with B-51-A handle repair kit.
- C. Relief valve is damaged. Replace relief valve.

#### 2. Handle leaks.

- A. Handle seal or handle assembly is damaged. Replace B-73-A handle or repair with B-51-A handle repair kit.

#### 3. Water splashes from fixture.

- A. Control stop is open wider than necessary. Adjust control stop for desired delivery of water volume.
- B. Water saver/conventional diaphragm assembly is installed on low consumption fixture or closet diaphragm assembly is installed on urinal fixture. Determine the required flush volume (see label on valve or markings on fixture). Replace diaphragm assembly or relief valve for appropriate flush volume of fixture.

#### 4. Volume of water is insufficient to adequately siphon fixture.

- A. Control stop is not open wide enough. Adjust control stop for desired delivery of water volume.
- B. Diaphragm assembly is damaged. Replace diaphragm assembly.
- C. Low consumption diaphragm assembly is installed on water saver/conventional fixture or urinal diaphragm assembly is installed on closet fixture. Determine the required flush volume (see label on valve or markings on fixture). Replace diaphragm assembly or relief valve for appropriate flush volume of fixture.
- D. Inadequate water volume or pressure is available from supply. Increase flow rate or pressure to the valve. If gauges are not available to measure supply pressure/volume, remove relief valve from diaphragm assembly and open the control stop.

If the fixture siphons: Additional water volume is required. Install higher flushing volume relief valve or diaphragm assembly or cut flow ring from guide. **IMPORTANT: LAWS AND REGULATIONS PROHIBIT THE USE OF HIGHER FLUSHING VOLUMES THAN LISTED ON FIXTURE OR FLUSHOMETER.**

If the fixture **DOES NOT** siphon (or a low consumption flush is required): Additional steps must be taken to increase the water pressure and/or volume at the water supply. Contact fixture manufacturer for minimum supply requirements of fixture.

#### 5. Flushometer valve closes immediately (short flush).

- A. Worn or damaged diaphragm assembly. Replace diaphragm assembly.
- B. Handle assembly is damaged. Replace B-73-A handle or repair with B-51-A handle repair kit.
- C. Low consumption diaphragm assembly is installed on water saver/conventional fixture or urinal diaphragm assembly is installed on closet fixture. Determine the required flush volume (see label on valve or markings on fixture). Replace relief valve or diaphragm assembly for appropriate flush volume of fixture.

#### 6. Length of flush is too long (long flush) or fails to shut off.

- A. Bypass hole (upper filter ring) of diaphragm assembly is dirty. Remove the diaphragm assembly. Disassemble the filter rings from the diaphragm, wash under running water, and reassemble. Replace as necessary.
- B. Relief valve or diaphragm assembly is damaged. Replace relief valve or diaphragm assembly.
- C. Water saver/conventional diaphragm assembly is installed on low consumption fixture or closet diaphragm assembly is installed on urinal fixture. Determine the required flush volume (see label on valve or markings on fixture). Replace diaphragm assembly or relief valve for appropriate flush volume of fixture.
- D. Inside cover is damaged. Install new A-71 part.
- E. Line water pressure dropped and is insufficient to close valve. Close the control stop until pressure is restored.
- F. Relief valve is not seated properly. Disassemble diaphragm components (relief valve, filter rings, and diaphragm unit), wash under running water, and reassemble. Replace as necessary.

#### 7. Chattering noise is heard during flush.

- A. Inside cover is damaged. Install new A-71 part.
- B. Relief valve or diaphragm assembly is damaged. Replace relief valve or diaphragm assembly.

### CARE AND CLEANING INSTRUCTIONS

**DO NOT USE** abrasive or chemical cleaners to clean flushometers that may dull the luster and attack the chrome or decorative finish. Use **ONLY** mild soap and water, then wipe dry with a clean towel or cloth. When cleaning the bathroom tile, protect the flushometer from any splattering of cleaner. Acids and cleaning fluids can discolor or remove chrome plating.

**When assistance is required, please contact  
Sloan Technical Support at: 1-888-SLOAN-14 (1-888-756-2614).**

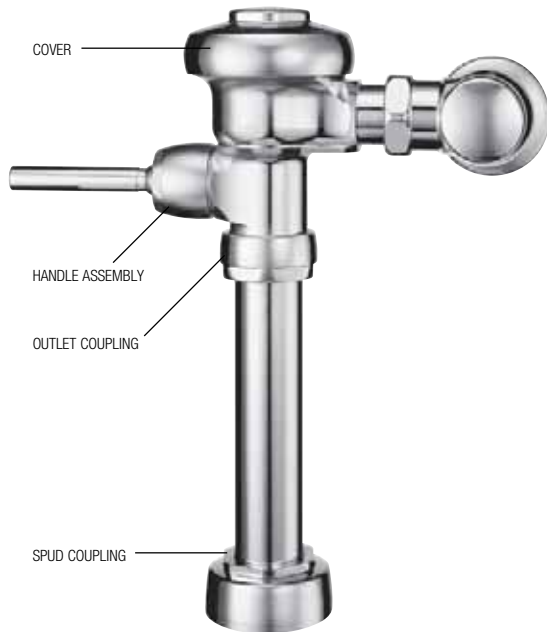

## Royal II® Flushometer

The Royal II® flushometer offers everything the Royal® has – and more. **PLEASE REFER TO THE ROYAL® SECTION** for all maintenance issues on the Royal II, with the exceptions noted in the chart below.

Royal II®'s new handle is a one-piece design for smoother lines. Its aesthetic cover accentuates the Royal II®'s new design, and the new vacuum breaker couplings and flange add the finishing touches.

### PARTS LIST

Code No.	Part No.	Description
0301298	A-206	Royal II® Cover
0302375	B-95-A	Royal II® Handle Assembly
0306145	F-56-A	Royal II® Spud Coupling Assembly 1-1/2" CP
0306128	F-57-A	Royal II® Spud Coupling Assembly 3/4" CP
0306127	F-58-A	Royal II® Spud Coupling Assembly 1-1/4" CP
0323369	V-572	Royal II® Coupling CP

**THIS PRODUCT IS NO LONGER AVAILABLE AS A COMPLETE ASSEMBLY. REPAIR PARTS REMAIN AVAILABLE FOR A LIMITED TIME.**

## Continental® Flushometer



The Continental® flushometer is part of the Sloan flushometer designer series, and offers proven Royal® performance – and more. **PLEASE REFER TO THE ROYAL® SECTION** for all maintenance issues on the Continental®, with the exceptions noted in the chart below.

Continental®'s sleek styling make it ideal for many applications.

### PARTS LIST

Code No.	Part No.	Description
0301077	A-4	Continental® Cover
0301221	A-71	Continental® Inside Cover

**THIS PRODUCT IS NO LONGER AVAILABLE AS A COMPLETE ASSEMBLY. REPAIR PARTS REMAIN AVAILABLE FOR A LIMITED TIME.**

### SLIP JOINT GASKETS AND RINGS

For additional information on Slip Joint Gaskets and Rings see Item 10A table at bottom of page 11.

# UPPERCUT® Dual-Flush Flushometer



**PARTS LIST**

Item No.	Code No.	Part No.	Description
1.	—	†	Valve Assembly
2.	<b>3372003</b>	WES-212	ADA Compliant Dual-Flush Handle
	<b>3372010</b>	WES-212	ADA Compliant Dual-Flush Handle (Spanish)
3.	<b>3308386</b>	H-700-A	Bak-Chek® Control Stop
4.	<b>3393007</b>	V-600-AA	1-1/2" (38 mm) x 9" (229 mm) Vacuum Breaker Assembly ‡
5.	<b>0306146</b>	F-5-AT	1-1/2" (38 mm) Spud Coupling Assembly
6.	<b>3308782</b>	H-633-AA	1" (25 mm) CP Sweat Solder Kit with Cast Set Screw Flange
7.	<b>5301139</b>	A-31	Handle Gasket – 48 per package
8.	<b>0372006</b>	WES-13	Wall Plate (English)
	<b>0372019</b>	WES-18	Wall Plate (Spanish)

† Part number varies with valve model variation; consult factory.  
 ‡ Length varies with valve model variation; consult factory.

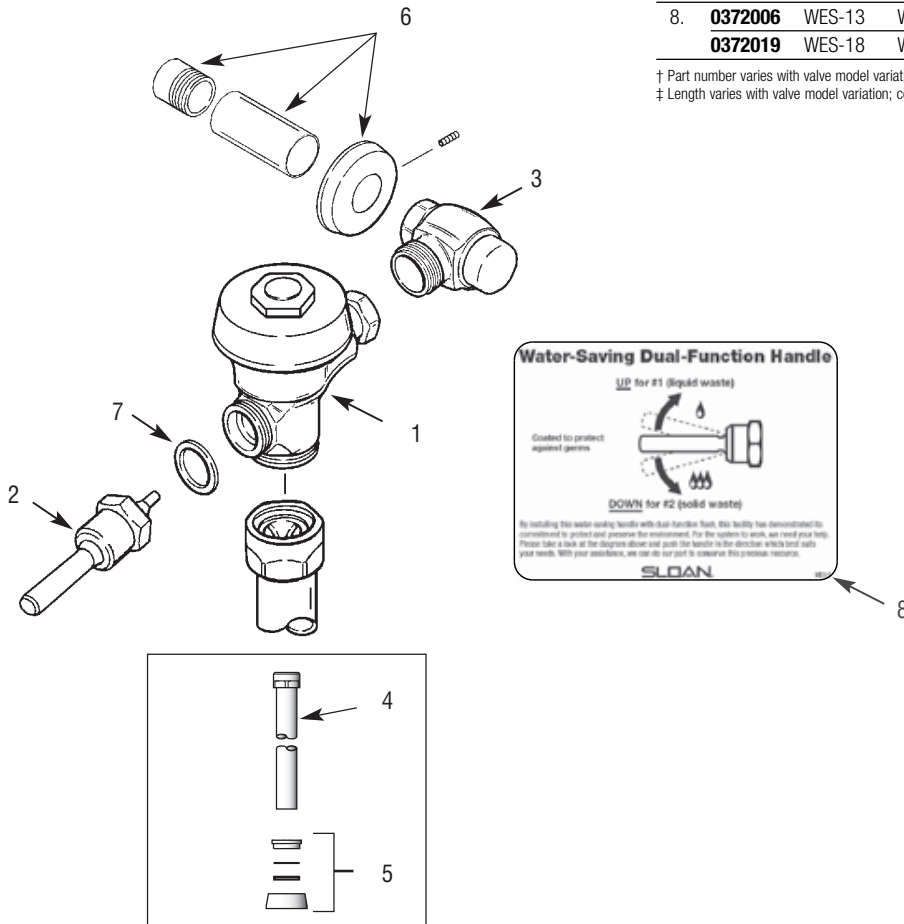

# Sloan Flushometer

Manual  
Flushometers

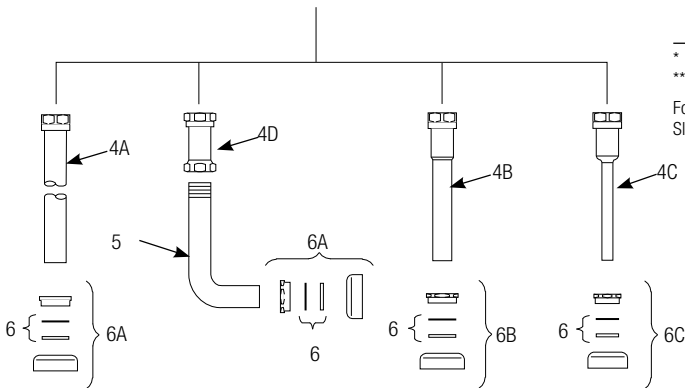
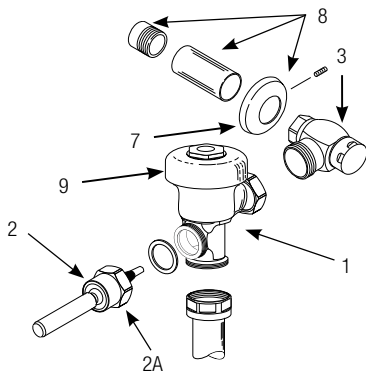

## PARTS LIST

Item No.	Code No.	Part No.	Description
1.	—	A-3-A	Valve Assembly – contact Tech Support for proper assembly
2.	<b>0302390</b>	B-73-A	ADA Compliant Handle Assembly
2A.	<b>0301082</b>	A-6	CP Handle Coupling
3.	—	H-710-A	Bak-Chek® Control Stop – 3/4" or 1"
4A.	<b>5323007</b>	V-500-AA	1-1/2" (38 mm) x 9" (229 mm) Vacuum Breaker Assembly ** – 6 per package
4B.	<b>5323006</b>	V-500-AA	1-1/4" (32 mm) x 9" (229 mm) Vacuum Breaker Assembly – 6 per package
4C.	<b>5323005</b>	V-500-AA	3/4" (19 mm) x 9" (229 mm) Vacuum Breaker Assembly – 6 per package
4D.	—	V-500-A	Vacuum Breaker Assembly
5.	<b>0396293</b>	F-109	1-1/2" (38 mm) Elbow Flush Connection
6.	<b>SEE SLIP JOINT GASKETS AND RINGS TABLE BELOW</b>		
6A.	<b>0306145</b>	F-56-A	1-1/2" (38 mm) Spud Coupling Assembly
6B.	<b>0306142</b>	F-55-A	1-1/4" (32 mm) Spud Coupling Assembly
6C.	<b>0306102</b>	F-54-A	3/4" (19 mm) Spud Coupling Assembly
7.	—	F-7	Supply Flange (Supplied when Valve is not Ordered with Sweat Solder Kit)
8.	<b>3308782</b>	H-633-AA	1" (25 mm) Sweat Solder Kit with Cast Set Screw Flange
	<b>3308788</b>	H-636-AA	3/4" (19 mm) Sweat Solder Kit with Cast Set Screw Flange
9.	<b>0378000PKSV-10</b>		CP Sloan Cover
	<b>0378003PKSV-10-HE</b>		CP High Efficiency Sloan Cover

\* Part number varies with valve model variation; consult factory.

\*\* Length varies with valve model variation; consult factory.

For optimum water conservation and flushometer performance, use only Genuine Sloan Parts.

## ITEM 6. SLIP JOINT GASKETS AND RINGS

Size	Code No.	Part No.	Description
1-1/2"	<b>5306058</b>	F-3	Red Friction Ring
	<b>5322001</b>	VBF-5	Black Slip Joint Gasket
	<b>0319086/5319086</b>	S-30	Flexible Seat
	<b>0319079</b>	S-21	Rigid Seat (rubber over brass)
1-1/2" x 1-1/4"	<b>0396062</b>	F-105	Slip Joint Gasket – Rigid
1-1/4"	<b>5306057</b>	F-3	Red Friction Ring
	<b>5322176</b>	VBF-5	Black Slip Joint Gasket
	<b>0307052/5307052</b>	G-21	Rigid Seat (rubber over brass)
1"	<b>5306056</b>	F-3	Red Friction Ring
	<b>5306115</b>	F-5	Black Slip Joint Gasket
3/4"	<b>5306055</b>	F-3	Red Friction Ring
	<b>5306113</b>	F-5	Black Slip Joint Gasket

# Sloan Flushometer

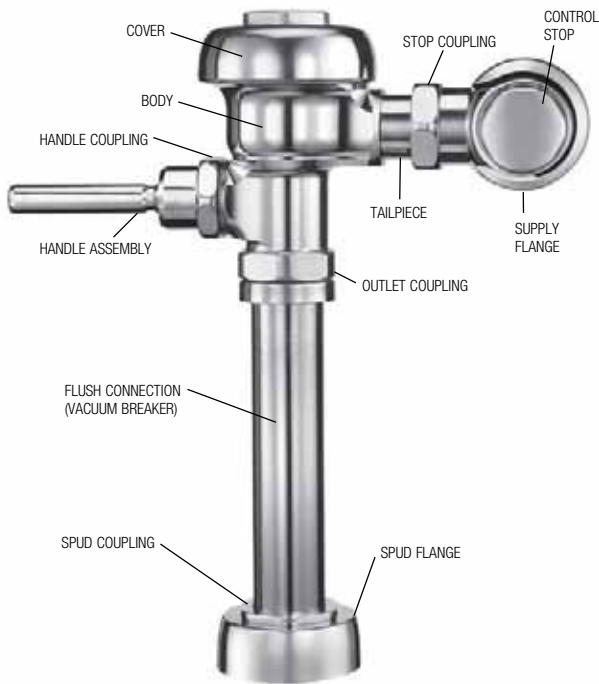

### DIAPHRAGM INSIDE PARTS KITS (SEE ILLUSTRATION BELOW)

Refer to Parts List. Includes Relief Valve and Diaphragm Assembly

Item No.	Code No.	Part No.	Application
A.	<b>3378041</b>	SV-41-A	1.6 gpf/6.0 Lpf - Closet
B.	<b>3378038</b>	SV-38-A	3.5 gpf/13.2 Lpf - Closet
C.	<b>3378044</b>	SV-44-A	2.4 gpf/9.0 Lpf - Closet
D.	<b>3378037</b>	SV-37-A	1.5 gpf/5.7 Lpf - Urinal
E.	<b>3378042</b>	SV-42-A	1.0 gpf/3.8 Lpf - Urinal
F.	<b>3378043</b>	SV-43-A	0.5 gpf/1.9 Lpf - Urinal
G.	<b>3378047</b>	SV-47-A	1.28 gpf/4.8 Lpf - Closet

### INSIDE COMPONENTS

Item No.	Code No.	Part No.	Description
1a.	<b>5301211</b>	A-19-ALC	Relief Valve, Green (Closet/Urinal-LC) – 12 per package
1b.	<b>5301058</b>	A-19-AC	Relief Valve, White (Closet) – 12 per package
1c.	<b>0301143</b>	A-19-AL	Relief Valve, Blue (9 Liter Closet)
1d.	<b>5301059</b>	A-19-AU	Relief Valve, Black (Urinal) – 12 per package

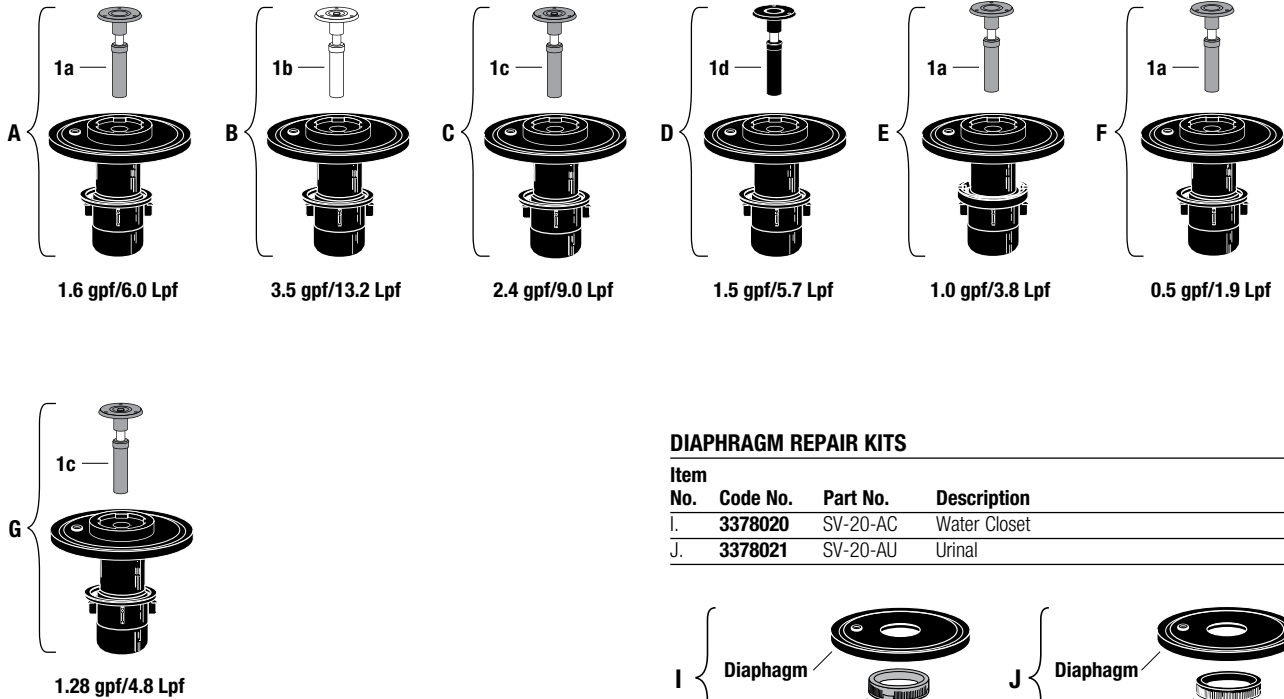

### DIAPHRAGM REPAIR KITS

Item No.	Code No.	Part No.	Description
I.	<b>3378020</b>	SV-20-AC	Water Closet
J.	<b>3378021</b>	SV-20-AU	Urinal

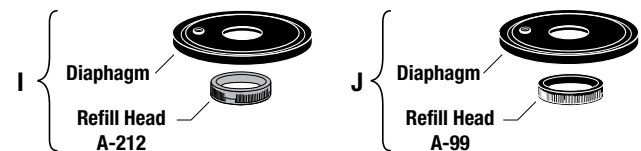

## Sloan Flushometer

### TROUBLESHOOTING GUIDE

**ATTENTION INSTALLERS:** With the exception of the control stop inlet, **DO NOT USE** pipe sealant or plumbing grease on any valve component or coupling! To protect the chrome or special finish of Sloan flushometers, **DO NOT USE** toothed tools to install or service these valves. Use our A-50 Super-Wrench or other smooth-jawed wrench to secure couplings. Regulations for low consumption fixtures (1.6 gpf/6.0 Lpf closets and 1.0 gpf/3.8 Lpf urinals) prohibit use of higher flush volumes.

#### 1. Flushometer DOES NOT function (no flush).

- Control stop or main valve is closed. Open control stop or main valve.
- Handle assembly is worn. Install handle repair kit or replace handle assembly.
- Relief valve is worn. Replace inside parts kit.

#### 2. Insufficient volume of water to adequately siphon fixture.

- Control stop not open enough. Adjust control stop for desired delivery of water volume.
- Urinal flushometer Parts inside a Closet flushometer. Replace inside urinal parts with proper closet flushometer parts.
- Low consumption flushometer installed on a non-low consumption fixture. Replace inside parts kit with water saver kit.
- Water saver kit installed in old, non-water saver bowl. Position refill head so that SIDE 1 is in the UP position.
- Water supply volume or pressure is inadequate. If no gauges are available to properly measure supply pressure or volume of water at the flushometer, then remove the relief valve from the inside parts kit, reassemble the flushometer and completely open the control stop.
  - If the fixture siphons, more water volume is required. If a 3.5 gpf inside parts kit is installed in the flushometer, then first flip the refill head (under the diaphragm) to obtain a 4.5 gpf volume. If this volume is still inadequate, remove the flow ring from the guide to obtain a 6.5 gpf kit. If additional flow is still required, try a low pressure guide kit. **IMPORTANT: LAWS AND REGULATIONS PROHIBIT THE USE OF HIGHER FLUSHING VOLUMES THAN LISTED ON FIXTURE OR FLUSHOMETER.**
  - If fixture does not siphon or if a Low Consumption fixture is installed, or if the above steps do not prove satisfactory, steps must be taken to increase the water supply pressure and/or volume. Contact the fixture manufacturer for minimum water supply requirements of the fixture.

#### 3. Flushometer closes off immediately.

- Ruptured or damaged diaphragm. Replace inside parts kit.
- Enlarged bypass orifice from corrosion or damage. Replace inside parts kit.

#### 4. Length of flush is too short (short flushing).

- Diaphragm assembly and guide assembly are not hand-tight. Screw the two assemblies hand-tight.
- Enlarged bypass orifice from corrosion or damage. Replace inside parts kit.
- Urinal flushometer parts inside a closet flushometer. Replace inside urinal parts with proper closet flushometer parts.
- Low consumption flushometer installed on a higher consumption fixture. Replace inside parts kit with water saver kit.
- Handle assembly is damaged. Replace handle.

#### 5. Length of flush is too long (long flushing) or continuous.

- Relief valve is not seating properly or bypass orifice is clogged because of foreign material, or bypass orifice is closed by an invisible gelatinous film from "over-treated" water. Disassemble the working parts and wash thoroughly.

**NOTE: SIZE OF ORIFICE IN THE BY-PASS IS EXTREMELY IMPORTANT FOR PROPER METERING OF WATER INTO THE UPPER CHAMBER OF THE FLUSHOMETER. DO NOT ENLARGE OR DAMAGE THIS ORIFICE. REPLACE INSIDE KIT IF CLEANING DOES NOT CORRECT PROBLEM.**

- Supply line water pressure has dropped and is not sufficient to close the valve. Close control stop until pressure has been restored.
- Closet flushometer parts inside an urinal flushometer. Replace Inside closet parts with proper urinal flushometer parts.
- Inside cover is damaged. Replace inside cover.

#### 6. Chattering noise is heard during flush.

- The segment diaphragm is installed upside-down. Replace the segment diaphragm to the proper position as instructed by markings on the diaphragm.
- Inside cover is damaged. Replace inside cover.

#### 7. Handle Leaks.

- Handle gasket, seal or assembly is damaged. Replace as required.

### CARE AND CLEANING INSTRUCTIONS

**DO NOT USE** abrasive or chemical cleaners (including chlorine bleach) to clean flushometers that may dull the luster and attack the chrome or special decorative finishes. Use **ONLY** mild soap and water, then wipe dry with a clean towel or cloth.

While cleaning the bathroom tile, protect the flushometer from any splattering of cleaner. Acids and cleaning fluids will discolor or remove chrome plating.

**When assistance is required, please contact  
Sloan Technical Support at: 1-888-SLOAN-14 (1-888-756-2614).**

# Regal® Flushometer

NOTE: Also for use with Regal® XL  
(Since mid-2010)

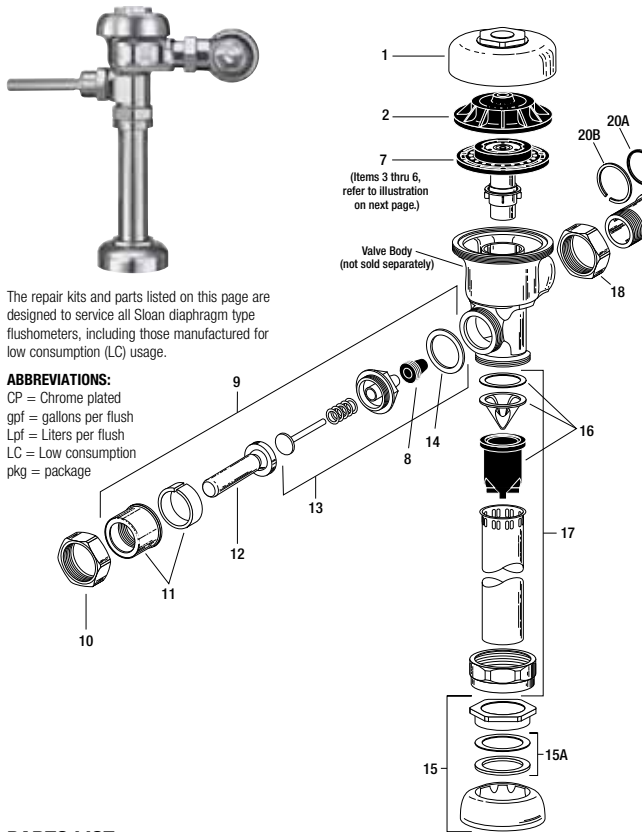

The repair kits and parts listed on this page are designed to service all Sloan diaphragm type flushometers, including those manufactured for low consumption (LC) usage.

**ABBREVIATIONS:**  
CP = Chrome plated  
gpf = gallons per flush  
Lpf = Liters per flush  
LC = Low consumption  
pkg = package

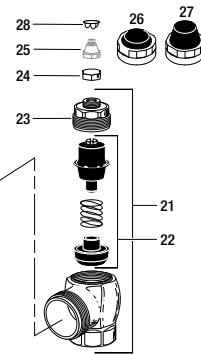

### TAILPIECES, CONTROL STOPS AND FLUSH CONNECTIONS

For additional information on tailpieces, control stops and flush connections see Showerheads, Parts and Accessories Tab.

### PARTS LIST

Item No.	Code No.	Part No.	Description
1.	0317004	R-10	CP Cover
	—	R-10-HE	CP High Efficiency Cover
2.	0301168	A-71	Inside Cover
<b>SEE ITEMS 3A THROUGH 6E IN CHART ON NEXT PAGE</b>			
3A.	5301058	A-19-AC	Relief Valve, White (Closet) – 12 per package
3B.	5301059	A-19-AU	Relief Valve, Black (Urinal) – 12 per package
3C.	5301211	A-19-ALC	Relief Valve, Green (Closet/Urinal-LC) – 12 per package
3D.	0301143	A-19-AL	Relief Valve, Blue (9 Liter Closet)
4.	5301111	A-15-A	Disc – for all Inside Parts Kits – 12 per package
5.	5301188	A-156-A	Diaphragm – for all Inside Parts Kits – 12 per package
6A.	5301236	A-163-A	Guide Assembly 4.5 gpf/17.0 Lpf Closet & 1.5 gpf/5.7 Lpf Urinal – 12 per package
6B.	5301032	A-152-A	Guide Assembly 3.5 gpf/13.2 Lpf Closet – 12 per package
6C.	5301031	A-151-A	Guide Assembly 1.6 gpf/6.0 Lpf LC Closet – 12 per package
6D.	5301155	A-155-A	Guide Assembly 1.0 gpf/3.8 Lpf LC Urinal – 12 per package
6E.	5301157	A-157-A	Guide Assembly 0.5 gpf/1.9 Lpf Urinal – 12 per package
7.	<b>SEE INSIDE PARTS KITS CHART ON NEXT PAGE</b>		
8.	5302297	B-39	Seal – 12 per package
9.	5302279	B-32-A	CP Handle Assembly – 6 per package
	0302390	B-73-A	CP Handicap Handle Assembly (ADA Compliant)
10.	0301082	A-6	CP Handle Coupling
11.	0302109	B-7-A	CP Socket Assembly
12.	5302274	B-32	CP Handle Grip – 12 per package
	0302389	B-74-A	CP Handicap Handle Grip (ADA Compliant)

### Item

No.	Code No.	Part No.	Description
13.	5302305	B-50-A	Handle Repair Kit – 6 per package
14.	5301139	A-31	Handle Gasket – 48 per package
15.	0306102	F-54-A	3/4" CP Spud Coupling Assembly
	0306142	F-55-A	1-1/4" CP Spud Coupling Assembly
	0306145	F-56-A	1-1/2" CP Spud Coupling Assembly
15A.	<b>SEE SLIP JOINT GASKETS AND RINGS TABLE BELOW</b>		
16.	3323192	V-551-A	Vacuum Breaker Repair Kit
17.	5323005	V-500-AA	3/4" x 9" CP Vacuum Breaker – 6 per package
	5323006	V-500-AA	1-1/4" x 9" CP Vacuum Breaker – 6 per package
	5323007	V-500-AA	1-1/2" x 9" CP Vacuum Breaker – 6 per package
18.	0308676	H-550	CP Stop Coupling†
19.	0308801	H-551-A	CP Adjustable Tailpiece 2-1/16" long†
20A.	5308696	H-553	O-ring – 24 per package
20B.	5308381	H-552	Locking ring – 12 per package
21.	0388065	H-790-A	1" Screwdriver Bak-Chek® Stop CP – complete
	0388064	H-790-A	3/4" Screwdriver Bak-Chek® Stop CP – complete
	0388029	H-740-A	1" Screwdriver Bak-Chek® Stop CP – <b>OBSOLETE</b>
	0388031	H-740-A	3/4" Screwdriver Bak-Chek® Stop CP – <b>OBSOLETE</b>
22.	3308853	H-541-ASD	1" Control Stop Repair Kit *
	3308856	H-543-ASD	3/4" Control Stop Repair Kit **
23.	0308612	H-622	CP Bonnet (Current Regal)
	0308991	H-639	CP Bonnet – Pre 2010 Regal Stops*
	0308601	H-538	CP Bonnet ** – <b>OBSOLETE</b>
24.	5388001	H-1012-A	CP Cap – 6 per package VP
25.	5310034	J-2/J-7	Bumper Assembly – 6 per package – <b>OBSOLETE</b>
26.	3308866	H-574	Stop Cap, chrome plated with Seat Bumper (-Y0)
27.	3308867	H-576	Stop Cap, chrome plated with Extended Seat Bumper (-YG)
28.	5388002	H-528	Hole Plug

† See pages 100-101 for additional lengths

\*For use with 1" and 3/4" H-740-A CP (less cap) and 1" – H-540-A CP (with H-37 cap) Bak-Chek® screwdriver control stops

\*\*For use with 3/4" H-740-A CP Bak-Chek® screwdriver control stops

### ITEM 15A. SLIP JOINT GASKETS AND RINGS

Size	Code No.	Part No.	Description
1-1/2"	5306058	F-3	Red Friction Ring
	5322001	VBF-5	Black Slip Joint Gasket
	0319086/5319086	S-30	Flexible Seat
1-1/2" x 1-1/4"	0319079	S-21	Rigid Seat (rubber over brass)
	0396062	F-105	Slip Joint Gasket – Rigid
1-1/4"	5306057	F-3	Red Friction Ring
	5322176	VBF-5	Black Slip Joint Gasket
1"	0307052/5307052	G-21	Rigid Seat (rubber over brass)
	5306056	F-3	Red Friction Ring
3/4"	5306115	F-5	Black Slip Joint Gasket
	5306055	F-3	Red Friction Ring
	5306113	F-5	Black Slip Joint Gasket

# Regal® Flushometer

NOTE: Also for use with Regal® XL  
(Since mid-2010)

Manual  
Flushometers

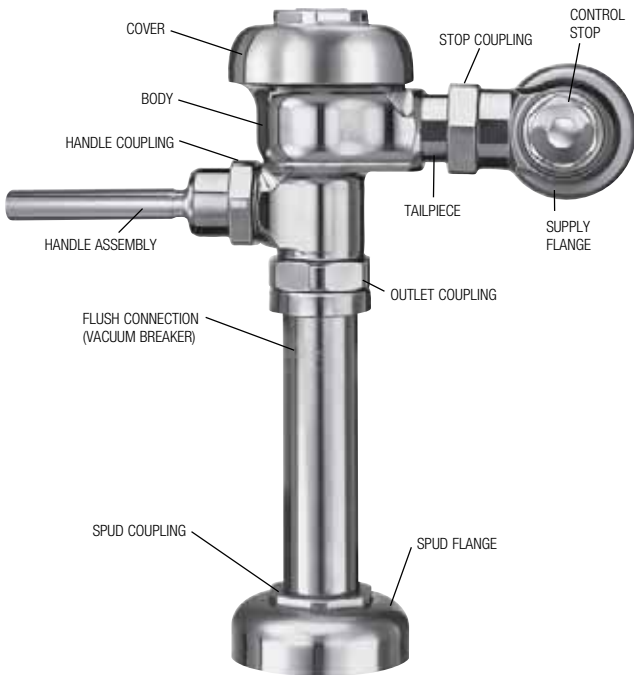

## MASTER FLUSHOMETER REBUILDING KITS (SEE PARTS LIST – ON PREVIOUS PAGE)

Refer to Parts List. Includes Items 7, 13, 16 & 20

Code No.	Part No.	Description
3317001	R-1001-A	Rebuild Kit (4.5 gpf/17.0 Lpf) Closet/Service Sink
3317002	R-1002-A	Rebuild Kit (1.5 gpf/5.7 Lpf) Urinal
3317003	R-1003-A	Rebuild Kit (3.5 gpf/13.2 Lpf) Closet
3317004	R-1004-A	Rebuild Kit (1.6 gpf/6.0 Lpf) Closet
3317005	R-1005-A	Rebuild Kit (1.0 gpf/3.8 Lpf) LC Urinal
3317011	R-1011-A	Rebuild Kit (0.5 gpf/1.9 Lpf) Urinal
3317012	R-1012-A	Rebuild Kit (2.4 gpf/9.0 Lpf) Closet

## REPAIR KIT WASHER SET (SEE PARTS LIST – ON PREVIOUS PAGE)

5301189	A-156-AA	Repair Kit Washer Set – Includes: 4, 5, 8 & 14
---------	----------	--

## ITEM 7. INSIDE PARTS KITS (SEE ILLUSTRATIONS BELOW)

Item No.	Code No.	Part No.	Application
A.	3301036	A-36-A	4.5 gpf/17.0 Lpf - Closet
B.	3301037	A-37-A	1.5 gpf/5.7 Lpf - Urinal
C.	3301038	A-38-A	3.5 gpf/13.2 Lpf - Closet
D.	3301041	A-41-A	1.6 gpf/6.0 Lpf - Closet
E.	3301044	A-42-A	1.0 gpf/3.8 Lpf - Urinal
F.	3301081	A-43-A	0.5 gpf/1.9 Lpf - Urinal
G.	3301024	A-44-A	2.4 gpf/9.0 Lpf - Closet

## ITEM 7. INSIDE PARTS COMPONENTS (SEE ILLUSTRATIONS BELOW)

Item No.	Code No.	Part No.	Description
3A.	5301058	A-19-AC	Relief Valve, White (Closet) – 12 per pkg.
3B.	5301059	A-19-AU	Relief Valve, Black (Urinal) – 12 per pkg.
3C.	5301211	A-19-ALC	Relief Valve, Green (Closet/Urinal-LC) – 12 per pkg.
3D.	0301143	A-19-AL	Relief Valve, Blue (9 Liter Closet)
4.	5301111	A-15-A	Disc – for all Inside Parts Kits – 12 per pkg.
5.	5301188	A-156-A	Diaphragm – for all Inside Parts Kits – 12 per pkg.
6A.	5301236	A-163-A	Guide Assembly 4.5 gpf/17.0 Lpf Closet & 1.5 gpf/5.7 Lpf Urinal – 12 per package
6B.	5301032	A-152-A	Guide Assembly 3.5 gpf/13.2 Lpf Closet – 12 per package
6C.	5301031	A-151-A	Guide Assembly 1.6 gpf/6.0 Lpf LC Closet – 12 per package
6D.	5301155	A-155-A	Guide Assembly 1.0 gpf/3.8 Lpf LC Urinal – 12 per package
6E.	5301157	A-157-A	Guide Assembly 0.5 gpf/1.9 Lpf Urinal – 12 per package

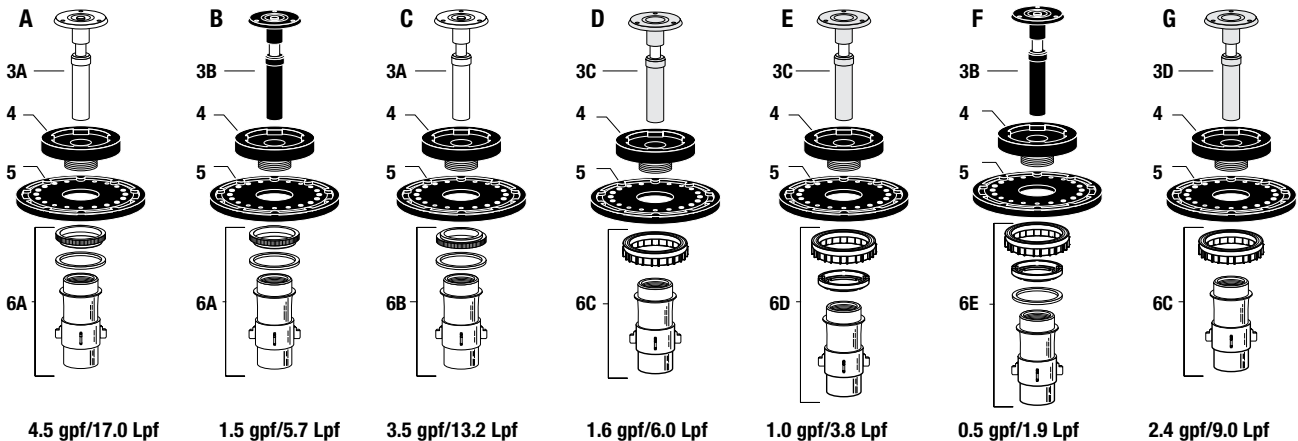

## Regal® Flushometer

NOTE: Also for use with Regal® XL  
(Since mid-2010)

### TROUBLESHOOTING GUIDE

**ATTENTION INSTALLERS:** With the exception of the control stop inlet, DO NOT USE pipe sealant or plumbing grease on any valve component or coupling! To protect the chrome or special finish of Sloan flushometers, DO NOT USE toothed tools to install or service these valves. Use our A-50 Super-Wrench™ or other smooth-jawed wrench to secure couplings. Regulations for low consumption fixtures (1.6 gpf/6.0 Lpf closets and 1.0 gpf/3.8 Lpf urinals) prohibit use of higher flush volumes.

#### 1. Flushometer DOES NOT function (no flush).

- Control stop or main valve is closed. Open control stop or main valve.
- Handle assembly is worn. Install handle repair kit B-50-A or replace handle.
- Relief valve is worn. Replace inside parts kit.

#### 2. Insufficient volume of water to adequately siphon fixture.

- Control stop not open enough. Adjust control stop for desired delivery of water.
- Urinal flushometer parts inside a closet flushometer. Replace inside urinal parts with proper closet flushometer parts.
- Low consumption flushometer installed on a non-low consumption fixture. Replace A-41-A inside parts kit with A-38-A water saver kit.
- Water saver kit installed in old, non-water saver bowl. Position refill head A-170-1 so that SIDE 1 is in the UP position.
- Inadequate volume or pressure at supply. If no gauges are available to properly measure supply pressure or volume of water at the flushometer, then remove the relief valve from the inside parts kit, reassemble the flushometer and open the control stop.
  - If the fixture siphons, more water volume is required. If a 3.5 gpf inside parts kit is installed in the flushometer, then first flip the refill head (under the diaphragm) to obtain a 4.5 gpf volume. If this volume is still inadequate, remove the flow ring from the guide to obtain a 6.5 gpf kit. If additional flow is still required, try a low pressure guide kit A-175-A. **IMPORTANT: LAWS AND REGULATIONS PROHIBIT THE USE OF HIGHER FLUSHING VOLUMES THAN LISTED ON FIXTURE OR FLUSHOMETER.**
  - If fixture does not siphon or if a low consumption fixture is installed, or if the above steps do not prove satisfactory, steps must be taken to increase the pressure and/or supply.

#### 3. Flushometer closes off immediately.

- Ruptured or damaged diaphragm. Install inside parts kit to correct above problems and update flushometer.
- Enlarged by-pass orifice from corrosion or damage. Install inside parts kit to correct above problem and update flushometer.

#### 4. Length of flush is too short (short flushing).

- Diaphragm assembly and guide assembly are not hand-tight. Screw the two assemblies hand-tight.
- Enlarged by-pass orifice from corrosion or damage. Install NEW inside parts kit to correct problem and update flushometer.
- A-19-AU (black) urinal relief valve in closet flushometer. Replace relief valve with A-19-AC (white) closet relief valve.
- B-41-A low consumption kit installed in non-low consumption fixture. Replace with proper inside parts kit.
- Handle assembly is worn. Install handle repair kit B-50-A or replace the handle.

#### 5. Length of flush is too long (long flushing) or fails to close off.

- Relief valve is not seating properly or by-pass orifice is clogged because of foreign material, or by-pass orifice is closed by an invisible gelatinous film from "over-treated" water. Disassemble the working parts and wash thoroughly.  
**NOTE: SIZE OF ORIFICE IN THE BY-PASS IS EXTREMELY IMPORTANT FOR PROPER METERING OF WATER INTO THE UPPER CHAMBER OF THE FLUSHOMETER. DO NOT ENLARGE OR DAMAGE THIS ORIFICE. REPLACE INSIDE KIT IF CLEANING DOES NOT CORRECT PROBLEM.**
- Line pressure has dropped and is not sufficient to force relief valve to seat. Shut off all control stops until pressure has been restored, then open them again.
- A-19-AC (white) closet relief valve has been used in a 1 or 1-1/2 gpf urinal. Replace with A-19-AU (black) relief valve.
- Inside cover is cracked or damaged. Replace the inside cover A-71.

#### 6. Chattering noise in flushometer.

- The A-156-A segment diaphragm has been installed upside-down. Replace the segment diaphragm to the proper position as instructed by markings on the diaphragm.
- The inside cover has been distorted from wear, freezing or abuse. replace inside cover.

#### 7. Leaking at handle assembly.

- The B-39 seal is worn or deteriorated. Install new B-39 seal.  
**NOTE: The B-39 seal will easily slide right onto the B-40 bushing if it is wet.**
- Handle gasket has been omitted. Install A-31 handle gasket or handle repair kit B-50-A.
- Valve handle bushing is worn. Install handle repair kit B-50-A.

### CARE AND CLEANING INSTRUCTIONS

**DO NOT USE** abrasive or chemical cleaners (including chlorine bleach) to clean flushometers that may dull the luster and attack the chrome or special decorative finishes. Use **ONLY** mild soap and water, then wipe dry with a clean towel or cloth.

While cleaning the bathroom tile, protect the flushometer from any splattering of cleaner. Acids and cleaning fluids will discolor or remove chrome plating.

**When assistance is required, please contact  
Sloan Technical Support at: 1-888-SLOAN-14 (1-888-756-2614).**

## Series 900® Flushometer

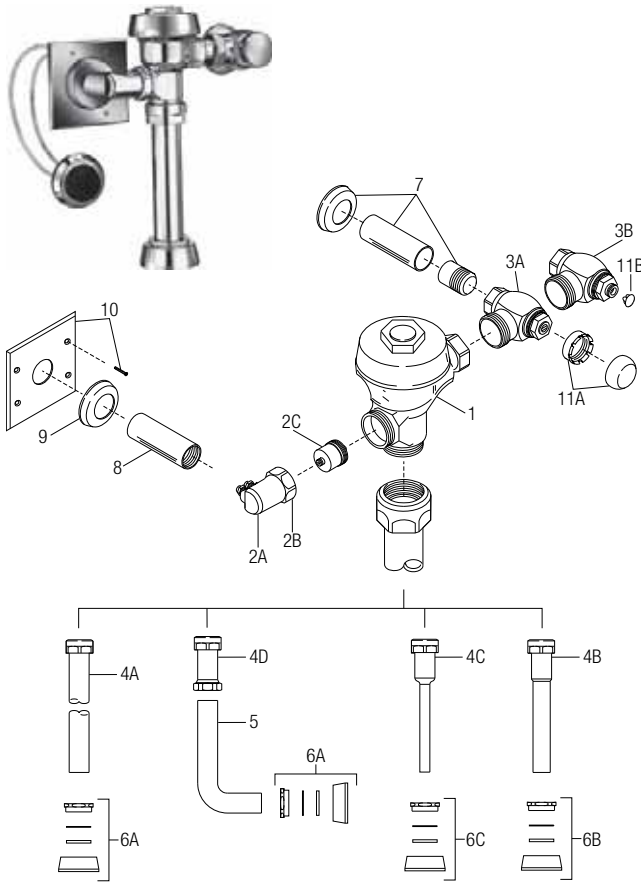

### PARTS LIST FOR SERIES 900® EXPOSED FLUSHOMETER

Item No.	Code No.	Part No.	Description
1.	<b>0301048</b>	A-143-A	Valve Body
2A.	<b>0318065PK</b>	HY-65	Valve Actuator Housing
2B.	<b>0301082PK</b>	A-6	Housing Nut
2C.	<b>3318001PK</b>	HY-83-A	Actuator Cartridge Assembly
3A.	<b>3308386</b>	H-700-A	Bak-Chek® Control Stop (Royal Valves) for 1" 3308384 for ¾"
3B.	<b>0388065</b>	H-790-A	Bak-Chek® Control Stop (Regal XL Valves) for 1" 0388064 for ¾"
4A.	<b>3893004</b>	V-600-AA	1½" (38 mm) Vacuum Breaker Assembly
4B.	<b>3393006</b>	V-600-AA	1¼" (32 mm) Vacuum Breaker Assembly
4C.	<b>3393004</b>	V-600-AA	¾" (19 mm) Vacuum Breaker Assembly
4D.	<b>0393003</b>	V-600-A	Vacuum Breaker
5.	<b>0396293</b>	F-109	1½" (38 mm) Elbow Flush Connection
6A.	<b>0306146</b>	F-5-AT	1-1/2" (38 mm) Spud Coupling Assembly (Royal Valves)
	<b>0306145</b>	F-56-A	1½" (38 mm) Spud Coupling Assembly (Regal XL Valves)
6B.	<b>0306140</b>	F-5-AU	1¼" (32 mm) Spud Coupling Assembly (Royal Valves)
	<b>0306142</b>	F-55-A	1¼" (32 mm) Spud Coupling Assembly (Regal XL Valves)
6C.	<b>0306125</b>	F-5-AW	¾" (19 mm) Spud Coupling Assembly (Royal Valves)
	<b>0306102</b>	F-54-A	¾" (19 mm) Spud Coupling Assembly (Regal XL Valves)
7.	<b>3308782</b>	H-633-AA	1" (25 mm) Sweat Solder Kit & Cast Wall Flange w/ Set Screw
	<b>3308788</b>	H-636-AA	¾" (19 mm) Sweat Solder Kit & Cast Wall Flange w/ Set Screw
8.	<b>0318064PK</b>	HY-64	6" Chrome Sleeve
9.	‡	F-7	Supply Flange
10.	<b>3318002</b>	HY-112-A	Plate with Screws
11A.	<b>3308772</b>	H-1010-A	Free Spinning Vandal Resistant Stop Cap (Royal Valves)
11B.	<b>5388002</b>	H-528	Vandal Resistant Hole Plug (Regal Valves)

† Part number varies with valve model variation; consult factory.

‡ Length varies with valve variation; consult factory.

## Series 900® Flushometer

### PARTS LIST FOR SERIES 900® CONCEALED FLUSHOMETER

Item No.	Code No.	Part No.	Description
1.	0301173	A-72	RB Royal® Cover
2.	0301168	A-71	Inside Cover
3.	<b>SEE THE INSIDE PARTS KIT CHART ON NEXT PAGE</b>		
4.	3323182	V-651-A	Vacuum Breaker Repair Kit
5.	0308690	H-550	RB Tailpiece Coupling
6.	0308802	H-551-A	RB Adjustable Tailpiece, 2-1/16" (52 mm)
7A.	5308696	H-553	O-ring – 24 per package
7B.	5308381	H-552	Locking ring – 12 per package
8.	0388010	H-730-A	RB Wheel Handle Bak-Chek® Control Stop
9A.	3308855	H-541-A	1" Wheel Handle Repair Kit for H-730-A Control Stop
9B.	3308858	H-543-A	3/4" Wheel Handle Repair Kit for H-730-A Control Stop
10.	0308919	H-558-A	Wheel Handle
11A.	0208083	H-623	1" RB Bonnet
11B.	0208083	H-623	3/4" RB Bonnet
12.	See page 111	V-600-AA	Royal Vacuum Breaker Flush Connection (specify length and size)
13.	0306619	F-2-AA	1-1/2" (38 mm) RB Couplings (2 each), Friction Rings (2 each), and Rubber Gaskets (2 each)
14.	0206146	F-21	RB Elbow
15.	0306091	F-2-A	1-1/2" (38 mm) RB Coupling and S-21 Flat Rigid Gasket
16.	See pages 111-116	F-100	RB Flared End Flush Connection (specify length)
17.	See pages 111-116	F-15-A	3/4" (19 mm) RB Elbow Flush Connection with Coupling and Rubber Gasket (specify length)
18.	0306054	F-2-A	3/4" (19 mm) RB Coupling, Friction Ring, and Rubber Gasket
19.	0318024	HY-25	RB Valve Actuator Housing ONLY
20.	0318093	HY-30	1/4" (6 mm) x 48" (1219 mm) Connecting Tubes (2 required)
21.	0301082	A-6	RB Handle Coupling Nut
22.	3318005	HY-109-A	Actuator Housing Assembly (includes items 21 & 24)
23.	3318001	HY-83-A	Actuator Cartridge Assembly
24.	0337086	DO-22	O-ring for HY-109-A Adapter
25.	<b>SEE SLIP JOINT GASKETS AND RINGS TABLE BELOW</b>		
26.	0301050	A143-A	RB Valve Body

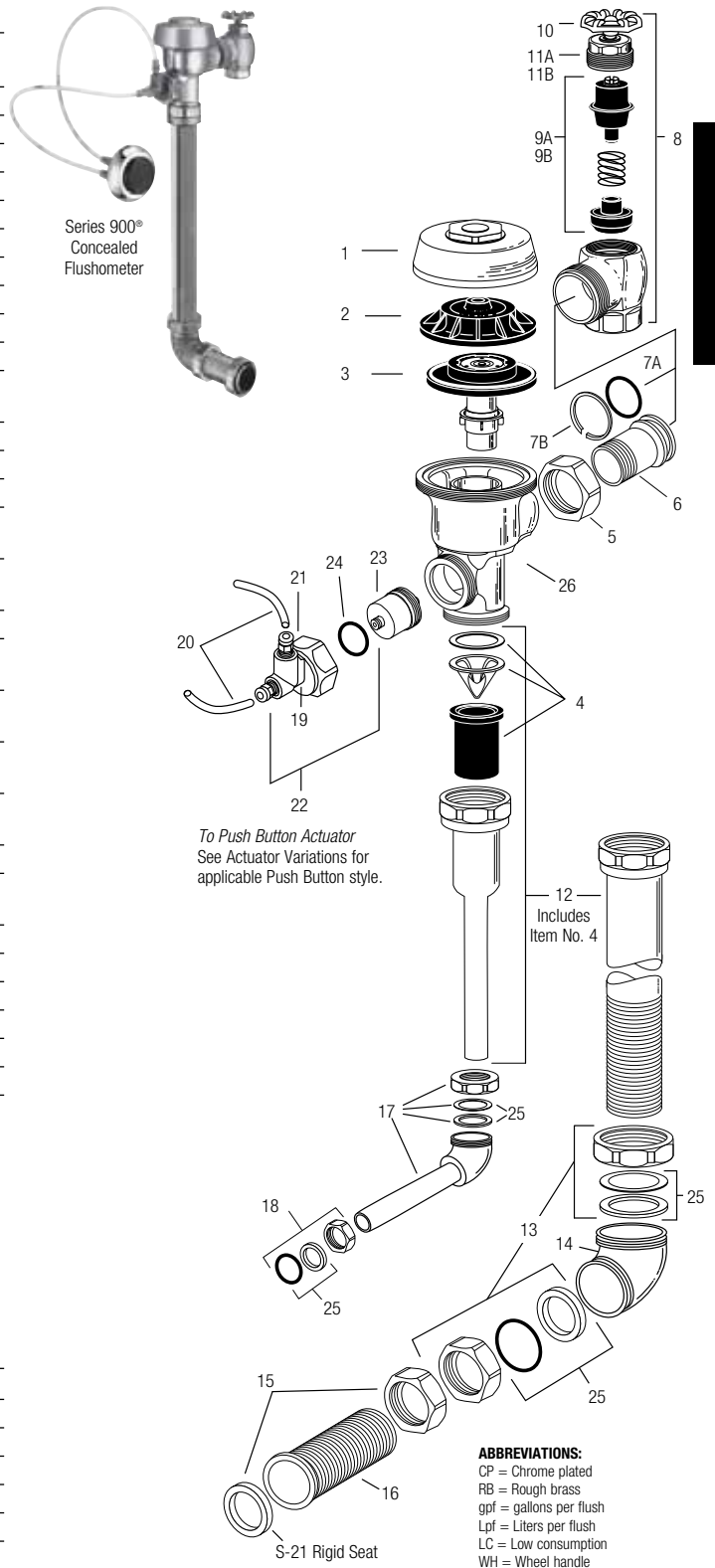

### ITEM 27. SLIP JOINT GASKETS AND RINGS

Size	Code No.	Part No.	Description
1-1/2"	5306058	F-3	Red Friction Ring
	5322001	VBF-5	Black Slip Joint Gasket
	0319086/5319086	S-30	Flexible Seat
	0319079	S-21	Rigid Seat (rubber over brass)
1-1/2" x 1-1/4"	0396062	F-105	Slip Joint Gasket – Rigid
1-1/4"	5306057	F-3	Red Friction Ring
	5322176	VBF-5	Black Slip Joint Gasket
	0307052/5307052	G-21	Rigid Seat (rubber over brass)
1"	5306056	F-3	Red Friction Ring
	5306115	F-5	Black Slip Joint Gasket
3/4"	5306055	F-3	Red Friction Ring
	5306113	F-5	Black Slip Joint Gasket

### TAILPIECES, CONTROL STOPS, PUSH BUTTONS AND FLUSH CONNECTIONS

For additional information on tailpieces, control stops, push buttons and flush connections see Showerheads, Parts and Accessories Tab.

## Series 900® Flushometer

Manual Flushometers

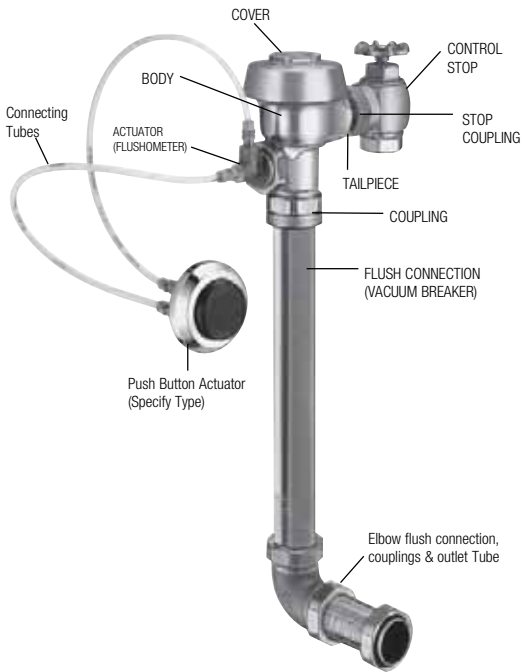

### ITEM 3. INSIDE PARTS KITS (SEE ILLUSTRATION ON PREVIOUS PAGE)

Code No.	Part No.	Application
<b>3301502</b>	A-1041-A	Low Consumption Water Closets-1.6 gpf (6.0 Lpf)*
<b>3301501</b>	A-1038-A	Water Saver Water Closets-3.5 gpf (13.2 Lpf)*
<b>3301505</b>	A-1044-A	9 Liter European Water Closets-2.4 gpf (9.0 Lpf)
<b>3301504</b>	A-1043-A	Wash Down Urinals-0.5 gpf (1.9 Lpf)
<b>3301503</b>	A-1042-A	Low Consumption Urinals-1.0 gpf (3.8 Lpf)*
<b>3301500</b>	A-1037-A	Water Saver Urinals-1.5 gpf (5.7 Lpf)*
<b>3301506</b>	A-1045-A	High-Efficiency Water Closets-1.28 gpf (4.8 Lpf)

\* Water Saver (3.5 gpf closet and 1.5 gpf urinal) and Low Consumption (1.6 gpf closet and 1.0 gpf urinal) fixtures must use matching gpf (Lpf) diaphragm kits; using a smaller gpf (Lpf) kit in fixtures not intended for less volume will result in inadequate dilution in urinals and improper evacuation in closets.

### HYDRAULIC INSIDE PARTS REPAIR KITS

Code No.	Part No.	Description
<b>3318011</b>	HY-1101-A	Hydraulic Royal 1.6C
<b>3318012</b>	HY-1102-A	Hydraulic Royal 3.5C
<b>3318013</b>	HY-1103-A	Hydraulic Royal 2.4C
<b>3318014</b>	HY-1106-A	Hydraulic Royal 0.5U
<b>3318015</b>	HY-1107-A	Hydraulic Royal 1.0U
<b>3318016</b>	HY-1108-A	Hydraulic Royal 1.5U

Comes with: Diaphragm, Actuator Cartridge Assembly, Tailpiece O-ring and Vacuum Breaker Assembly



## Series 900® Flushometer

### HY-49-A (0318049) METAL PARTITION PUSH BUTTON

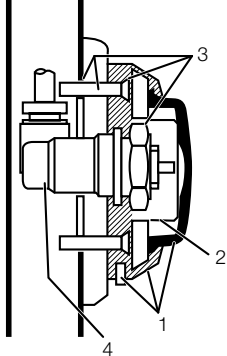

Item No.	Code No.	Part No.	Description
1.	3318007	HY-1000-A	Push Button Kit – includes Push Button, Flange, Spring & Set Screw
2.	0318004	HY-3	Spring
3.	3318010	HY-1003-A	Mounting Flange Kit – includes Mounting Flange, Mounting Nut, Screws (2) & Tinnerman Nuts (2)
4.	0318123	HY-71-A	Actuator Assembly

NOTE: Includes HY-32-A cartridge (shown at right)  
NOTE: Maximum distance from button to valve is 20' (longer tubing required)

### HY-72-A (0318072) SIDE WALL PUSH BUTTON

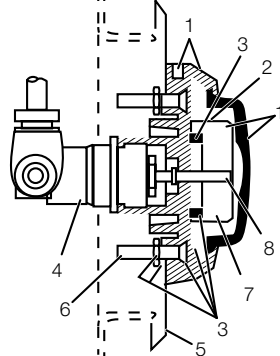

Item No.	Code No.	Part No.	Description
1.	3318007	HY-1000-A	Push Button Kit – includes Push Button, Flange, Spring & Set Screw
2.	0318004	HY-3	Spring
3.	3318008	HY-1001-A	Mounting Flange Kit – includes Mounting Flange, Mounting Nut, Screws (2), Nuts (2) & Washers (2)
4.	0318123	HY-71-A	Actuator Assembly
5.	0318041	HY-40	Plate
6.	0305173	EL-173	Screws (4)
7.	0318073	HY-73	Extension Adapter
8.	0318074	HY-74	Extension Stem

NOTE: Includes HY-32-A cartridge (shown at right)  
NOTE: Maximum distance from button to valve is 20' (longer tubing required)

### HY-108-A (0318119) PENAL WARE METAL PUSH BUTTON

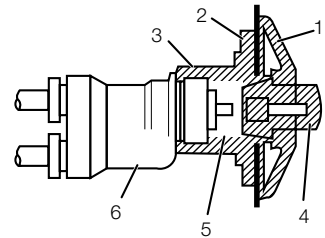

Item No.	Code No.	Part No.	Description
1.	0318116	HY-91	Flange
2.	0318111	HY-94	Mounting Washer
3.	0318112	HY-93	Mounting Nut
4.	0318115	HY-86-A	Push Button Assembly
5.	0305134	EL-109	Spring
6.	0318078	HY-50-A	Actuator Assembly

NOTE: Includes HY-32-A cartridge (shown below)  
NOTE: Maximum distance from button to valve is 20' (longer tubing required)

### HY-32-A ACTUATOR CARTRIDGE ASSEMBLY



For use with HY-50-A and HY-71-A actuator assemblies

### HY-100-A (0318117) FIXTURE WALL METAL PUSH BUTTON

Item No.	Code No.	Part No.	Description
1.	0318117	HY-100-A	Fixture Wall Metal Button Assembly
2.	3318006	HY-111-A	Metal Button Kit
3.	0305134	EL-109	Spring
4.	0318078	HY-50-A	Actuator Assembly
5.	0318028	HY-29	Threaded Rod
6.	0318109	HY-105	Spacer
7.	3318009	HY-1002-A	Mounting Strap Kit

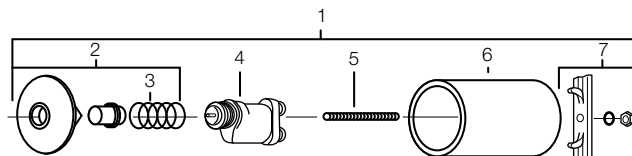

### HY-33-A (0318001) FIXTURE WALL PUSH BUTTON

1.	0318001	HY-33-A	Fixture Wall Push Button Assembly
2.	3318007	HY-1000-A	Push Button Kit
3.	0318004	HY-3	Spring
4.	3318008	HY-1001-A	Mounting Flange Kit
5.	0318078	HY-50-A	Actuator Assembly
6.	0318028	HY-29	Threaded Rod
7.	0318109	HY-105	Spacer
8.	3318009	HY-1002-A	Mounting Strap Kit

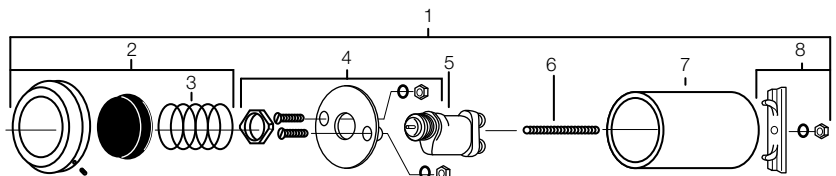

## Series 900® Flushometer

### TROUBLESHOOTING GUIDE

#### 1. Push button leaks.

The actuator cartridge has an accumulation of lime or its seals are damaged or worn. Replace with a new HY-32-A cartridge.

#### 2. The flushometer DOES NOT flush and a small amount of leakage is visible below the valve.

- A. Foreign material lodged in the cartridge. Remove the cartridge and inspect for foreign material. Clean under running water.
- B. The actuator cartridge has an accumulation of lime or its seals are damaged or worn. Replace with a new HY-32-A cartridge.
- C. Plastic tubing is installed incorrectly. Install plastic tubing correctly.

#### ACTUATOR CARTRIDGE REMOVAL

##### Plastic Push Button Actuator Removal:

- (1) Loosen the setscrew in the button flange and remove the button, flange, and spring from the actuator body.
- (2) Unscrew the cartridge from the actuator body.

**NOTE: An automatic check valve in the actuator body allows removal of the cartridge without turning off the water.**

##### Metal Push Button Actuator Removal:

- (1) Remove the button or actuator assembly from the wall or fixture.
- (2) Disassemble the flange or button assembly from the actuator body.
- (3) Unscrew the cartridge from the actuator body.

**NOTE: The metal push button is designed to be vandal-proof and must be removed from the wall or fixture for service.**

#### 3. The flushometer DOES NOT flush or flushes only once and will not flush a second time when the button is pushed.

- A. The plunger is lodged in the actuator cartridge or the plunger bypass hole is clogged. Remove actuator housing and cartridge from the flushometer. Clean under running water. If cartridge parts are worn, deteriorated or limed up and problem persists after cleaning, replace with a new HY-83-A cartridge.
- B. Plastic tubing is installed incorrectly. Install plastic tubing correctly.

#### REMOVAL OF THE ACTUATOR FROM THE FLUSHOMETER:

Turn off water at the control stop. Unscrew the actuator housing coupling nut from the flushometer. Remove the actuator housing from the flushometer. The tubing connections can be left intact. Carefully remove the actuator cartridge from the flushometer body to prevent the actuator from abrupt separation due to expansion of an internal spring. If the actuator cartridge is lodged in the flushometer body cavity, gently grip the exposed portion of the cartridge with a channel-lock pliers and rotate back and forth to loosen the o-ring seal. Carefully separate the actuator housing to reveal the spring and plunger.

#### 4. Flushometer DOES NOT function (no flush).

- A. Control stop or main valve is closed. Open control stop or main valve.
- B. Relief valve is worn. Replace performance kit (Royal) or inside parts kit (Regal XL).

#### 5. Volume of water is not sufficient to siphon fixture.

- A. Control stop is not open wide enough. Adjust control stop for desired delivery of water volume.
- B. Urinal flushometer parts installed in a closet flushometer. Replace inside urinal flushometer parts with proper closet flushometer parts.
- C. Incorrect dual-filtered diaphragm assembly (Royal) or inside parts kit (Regal XL) is installed in flushometer; for instance, urinal assembly inside a closet flushometer, or low consumption assembly inside a higher consumption fixture. Determine the flush volume required by the fixture and replace Royal performance kit or inside parts kit. Use valve label and markings on fixture for reference.
- D. Water supply volume or pressure is inadequate. If no gauges are available to properly measure supply pressure or volume of water at the flushometer, then remove the relief valve from the dual-filtered diaphragm assembly (Royal) or inside parts kit (Regal XL), reassemble the flushometer and completely open the control stop. If the fixture siphons, more water volume is required.

**For Royal** — Install a higher flushing volume Royal Performance Kit.

**For Regal XL** — If a 3.5 gpf Inside Parts Kit is installed in the flushometer, then first flip the refill head (under the diaphragm) to obtain a 4.5 gpf volume. If this volume is still inadequate, remove the flow ring from the guide to obtain a 6.5 gpf Kit. If additional flow is still required, try a low pressure guide kit A-175-A (0301104).

#### IMPORTANT — LAWS AND REGULATIONS REQUIRING PROHIBIT THE USE OF HIGHER FLUSHING VOLUMES THAN LISTED ON FIXTURE OR FLUSHOMETER.

If the fixture does not siphon or if a low consumption flush is required, steps must be taken to increase the water supply pressure and/or volume. Contact the fixture manufacturer for minimum water supply requirements of the fixture.

#### 6. Flushometer closes off immediately.

- A. Ruptured or damaged diaphragm. Replace Royal performance kit (Royal) or inside parts kit (Regal XL).
- B. **For Regal XL**— An enlarged bypass orifice from corrosion or damage. Replace inside parts kit.
- 7. Length of flush is too short (Short Flush).
- A. **For Regal XL** — The diaphragm assembly and guide assembly are not hand tight. Screw the two assemblies hand tight.
- B. **For Regal XL** — An enlarged bypass orifice from corrosion or damage. Replace inside parts kit.
- C. Dual-filtered diaphragm assembly (Royal) or inside parts kit (Regal XL) is damaged. Replace Royal performance kit or inside parts kit.
- D. Incorrect dual-filtered diaphragm assembly (Royal) or inside parts kit (Regal XL) is installed in flushometer; for instance, urinal assembly inside a closet flushometer, or low consumption assembly inside a higher consumption fixture. Determine the flush volume required by the fixture and replace Royal performance kit or inside parts kit. Use valve label and markings on fixture for reference.

## Series 900® Flushometer

### TROUBLESHOOTING GUIDE (CONTINUED)

#### 7. Length of flush is too long (long flush) or continuous.

- A. **For Royal** — Metering bypass hole in diaphragm is clogged. Remove the dual-filtered diaphragm assembly. Remove the primary and secondary filter rings from the diaphragm and wash under running water. Replace Royal performance kit if cleaning does not correct the problem.
- B. **For Regal XL** — Relief valve (A-19-A) is not seating properly or bypass orifice is clogged. Disassemble the working parts and wash thoroughly.

**NOTE: SIZE OF THE ORIFICE IN THE BYPASS IS OF UTMOST IMPORTANCE FOR THE PROPER METERING OF WATER INTO THE UPPER CHAMBER OF THE FLUSHOMETER. DO NOT ENLARGE OR DAMAGE THIS ORIFICE. REPLACE INSIDE PARTS KIT IF CLEANING DOES NOT CORRECT PROBLEM.**

- C. Supply line water pressure has dropped and is not sufficient to close the valve. Close control stop until pressure is restored.
- D. Dual-filtered diaphragm assembly (Royal) or inside parts kit (Regal XL) is damaged. Replace Royal performance kit or inside parts kit.
- E. Incorrect dual-filtered diaphragm assembly (Royal) or inside parts kit (Regal XL) is installed in flushometer; for instance, urinal assembly inside a closet flushometer, or low consumption assembly inside a higher consumption fixture. Determine the flush volume required by the fixture and replace Royal performance kit or inside parts kit. Use valve label and markings on fixture for reference.
- F. White closet relief valve has been used in a urinal flushometer. Replace closet relief valve (A-19-AC) with black urinal relief valve (A-19-AU).
- G. Inside cover is cracked or damaged. Replace the inside cover (A-71).
- H. Conditions in the piping system may contribute to the noise. A degree of high pressure in the piping may be relieved by adjustments to control stop. Other noises created by loose pipes, lack of air chambers, inadequate pipe sizes, etc., are problems that must be discussed with the building engineer.

#### 8. Chattering noise is heard during flush.

- A. Inside cover is damaged. Replace inside cover (A-71).
- B. **For Regal XL** — A-156-A segment diaphragm has been installed upside-down. Reposition the segment diaphragm properly (see markings on the diaphragm).

### CARE AND CLEANING INSTRUCTIONS

**DO NOT USE** abrasive or chemical cleaners (including chlorine bleach) to clean flushometers that may dull the luster and attack the chrome or special decorative finishes. Use **ONLY** mild soap and water, then wipe dry with a clean towel or cloth.

While cleaning the bathroom tile, protect the flushometer from any splattering of cleaner. Acids and cleaning fluids will discolor or remove chrome plating.

**When assistance is required, please contact Sloan Technical Support at: 1-888-SLOAN-14 (1-888-756-2614).**

## Concealed Flushometer (Royal®)

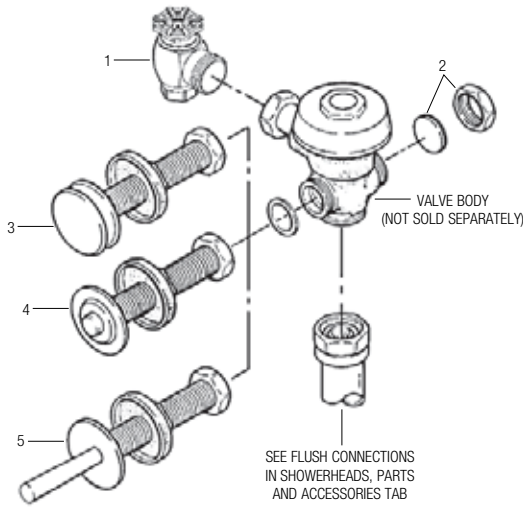

### TAILPIECES, CONTROL STOPS, FLUSH CONNECTIONS AND HANDLE ASSEMBLIES

For additional information on tailpieces, control stops, flush connections, and handle assemblies see Showerheads, Parts and Accessories Tab.

### PARTS LIST

Item No.	Code No.	Part No.	Description
1.	<b>0388010</b>	H-730-A	1" RB Wheel Handle Bak-Chek® Control Stop
	<b>0388011</b>	H-730-A	3/4" RB Wheel Handle Bak-Chek® Control Stop
2.	<b>3301093</b>	A-1013-A	Concealed Valve Handle Cap Kit
<b>FOR SPECIFYING PROPER LENGTHS FOR ITEMS 3, 4 AND 5, SEE CHART BELOW</b>			
3.	—	C-43-A	3" (76 mm) Push Button Actuator Assembly
4.	—	C-9-A	Blind Nut Push Button Actuator Assembly
5.	—	B-12-A	Lever Actuator Assembly

### Specify the "L" dimension for the proper length of the push button assembly

"L" Dimension PUSH BUTTON ID CHART (All dimensions in inches)

Wall Thickness	1	2	3	4	5	6	7	8	9	10	11	12	13	14	15
"L" Dimension	3 3/4	4 3/4	5 3/4	6 3/4	7 3/4	8 3/4	9 3/4	10 3/4	11 3/4	12 3/4	13 3/4	14 3/4	15 3/4	16 3/4	17 3/4
"A" (B-15-A) Filler Rod	1 5/8	2 5/8	3 5/8	4 5/8	5 5/8	6 5/8	7 5/8	8 5/8	9 5/8	10 5/8	11 5/8	12 5/8	13 5/8	14 5/8	15 5/8
"B" (B-6-A) Socket Assembly	2 1/2	3 1/2	4 1/2	5 1/2	6 1/2	7 1/2	8 1/2	9 1/2	10 1/2	11 1/2	12 1/2	13 1/2	14 1/2	15 1/2	16 1/2

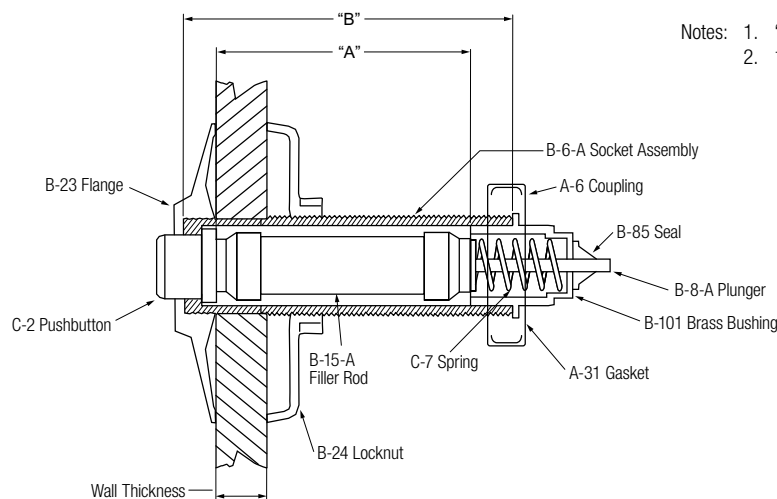

- Notes: 1. "L" Dimension = Wall thickness (to nearest whole inch) + 2 3/4"  
 2. 1 1/2" Diameter Hole Opening Required Through Wall

## Concealed Flushometer (Royal®)

### TROUBLESHOOTING GUIDE

**ATTENTION INSTALLERS:** With the exception of the control stop inlet, **DO NOT USE** pipe sealant or plumbing grease on any valve component or coupling! To protect the chrome or special finish of Sloan flushometers, **DO NOT USE** toothed tools to install or service these valves. Use our A-50 Super Wrench or other smooth-jawed wrench to secure couplings. Regulations for low consumption fixtures (1.6 gpf/6.0 Lpf closets and 1.0 gpf/3.8 Lpf urinals) prohibit use of higher flush volumes.

#### 1. Flushometer DOES NOT function.

- Control stop or main valve is closed. Open control stop or main valve.
- Handle or push button assembly is worn. Install Sloan handle repair kit (C-70-A) or replace handle or push button.
- Relief valve is worn. Replace inside parts kit.

#### 2. Insufficient volume of water to adequately siphon fixture.

- Control stop not open enough. Adjust control stop for desired delivery of water.
- Urinal flushometer parts inside a closet flushometer. Replace inside urinal parts with proper closet flushometer Parts.
- Low consumption flushometer installed on a non-low consumption fixture. Replace A-41-A inside parts kit with A-38-A water saver kit.
- Water saver kit installed in old, non-water saver bowl. Position refill head A-170 so that SIDE 1 is in the UP position.
- Inadequate volume or pressure at supply.
  - If no gauges are available to properly measure supply pressure or volume of water at the flushometer, then remove the relief valve from the inside parts kit, reassemble the flushometer and open the control stop. If the fixture siphons, more water volume is required. If a 3.5 gpf inside parts kit is installed in the flushometer, then first flip the refill head (under the diaphragm) to obtain a 4.5 gpf volume. If this volume is still inadequate, remove the flow ring from the guide to obtain a 6.5 gpf kit. If additional flow is still required, try a low pressure guide kit A-175-A (#0301104).

**IMPORTANT: Laws and regulation prohibit the use of higher flushing volumes than listed on fixture or flushometer.**

  - If fixture **DOES NOT** siphon or if a low consumption fixture is installed, or if the above steps do not prove satisfactory, steps must be taken to increase the pressure and/or supply.

#### 3. Flushometer closes off immediately.

- Ruptured or damaged diaphragm. Install inside parts kit to correct problem and update flushometer.
- Enlarged bypass orifice from corrosion or damage. Install inside parts kit to correct problem and update flushometer.

#### 4. Length of flush is too short (short flushing).

- Diaphragm assembly and guide assembly are not hand-tight. Screw the two assemblies hand-tight.
- Enlarged bypass orifice from corrosion or damage. Install NEW inside parts kit to correct problem and update flushometer.
- A-19-AU (Black) urinal relief valve in closet flushometer. Replace relief valve with A-19-AC (White) closet relief valve.
- A-41-A low consumption kit installed in non-low consumption fixture. Replace with proper Inside Parts Kit.
- Handle assembly is worn. Install handle repair kit (C-70-A) or replace the handle.

#### 5. Length of flush is too long (Long Flushing) or fails to close off.

- Relief valve is not seating properly or bypass orifice is clogged because of foreign material, or bypass orifice is closed by an invisible gelatinous film from "over-treated" water. Disassemble the working parts and wash thoroughly. **NOTE: SIZE OF ORIFICE IN THE BYPASS IS EXTREMELY IMPORTANT FOR PROPER METERING OF WATER INTO THE UPPER CHAMBER OF THE FLUSHOMETER. DO NOT ENLARGE OR DAMAGE THIS ORIFICE. REPLACE INSIDE KIT IF CLEANING DOES NOT CORRECT PROBLEM.**
- Line pressure has dropped and is not sufficient to force relief valve to seat. Shut off all control stops until pressure has been restored, then open them again.
- A-19-AC (White) closet relief valve has been used in a 1.0 or 1.5 gpf urinal. Replace with A-19-AU (Black) relief valve.
- Inside cover is cracked or damaged. Replace the inside cover (A-71).

#### 6. Chattering noise in flushometer.

- The A-156-A segment diaphragm has been installed upside-down. Replace the segment diaphragm to the proper position as instructed by markings on the diaphragm.
- The inside cover has become distorted from wear, freezing or abuse. Replace inside cover.

#### 7. Leaking at handle or push button assembly.

- The B-39 Seal is worn or deteriorated. Install new B-39 seal. **NOTE: The B-39 Seal will easily slide onto the B-40 Bushing if it is wet.**
- Handle gasket has been omitted. Install A-31 handle gasket or Sloan handle repair kit (C-70-A).
- Valve handle bushing is worn. Install Sloan handle repair kit (C-70-A).

### CARE AND CLEANING INSTRUCTIONS

**DO NOT USE** abrasive or chemical cleaners (including chlorine bleach) to clean flushometers that may dull the luster and attack the chrome or special decorative finishes. Use **ONLY** mild soap and water, then wipe dry with a clean towel or cloth.

While cleaning the bathroom tile, protect the flushometer from any splattering of cleaner. Acids and cleaning fluids will discolor or remove chrome plating.

**When assistance is required, please contact Sloan Technical Support at: 1-888-SLOAN-14 (1-888-756-2614).**

# Crown® Flushometer

## Crown® II (Obsolete)

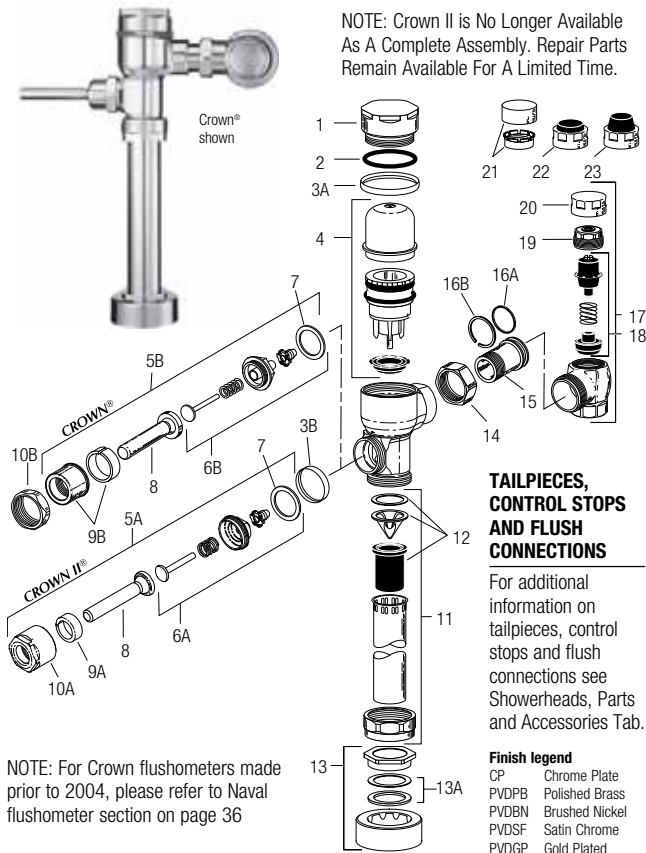

**TAILPIECES, CONTROL STOPS AND FLUSH CONNECTIONS**

For additional information on tailpieces, control stops and flush connections see Showerheads, Parts and Accessories Tab.

**Finish legend**

CP	Chrome Plate
PVDPB	Polished Brass
PVDBN	Brushed Nickel
PVDSF	Satin Chrome
PVDGP	Gold Plated

NOTE: For Crown flushometers made prior to 2004, please refer to Naval flushometer section on page 36

**PARTS LIST**

Item No.	Code No.	Part No.	Description
1.	0332006	CR-116	CP Cover
2.	0332030	CR-133	Cover O-ring
3.	0332045	CR-132-A	CP Handle and Cover Trim Ring Kit (Includes items 3A & 3B) (CROWN® II ONLY)
	0332046	CR-132-A	PVDPB Handle and Cover Trim Ring Kit (Includes items 3A & 3B) (CROWN® II ONLY)
	0332048	CR-132-A	PVDBN Handle and Cover Trim Ring Kit (Includes items 3A & 3B) (CROWN® II ONLY)
	0332049	CR-132-A	PVDSF Handle and Cover Trim Ring Kit (Includes items 3A & 3B) (CROWN® II ONLY)
3A.	0332035	CR-134	Cover Trim Ring (CROWN® ONLY)
	0332009	CR-120	PVDPB Cover Trim Ring (CROWN® II ONLY)
	0332032	CR-120	PVDGP Cover Trim Ring (CROWN® II ONLY)
	0332033	CR-120	PVDBN Cover Trim Ring (CROWN® II ONLY)
	0332034	CR-120	PVDSF Cover Trim Ring (CROWN® II ONLY)
3B.	0332005	CR-113	PVDPB Handle Trim Ring (CROWN® II ONLY)
	0332028	CR-113	PVDBN Handle Trim Ring (CROWN® II ONLY)
	0332029	CR-113	PVDSF Handle Trim Ring (CROWN® II ONLY)
4.	3332003	CR-1004-A	Piston Kit – 1.6 gpf (6.0 Lpf) Water Closet
	3332013	CR-1011-A	Piston Kit – 1.28 gpf (4.8 Lpf) Water Closet
	3332004	CR-1005-A	Piston Kit – 1.0 gpf (3.8 Lpf) Urinal
	3332005	CR-1006-A	Piston Kit – 0.5 gpf (1.9 Lpf) Urinal
	3332017	CR-1015-A	Piston Kit – 0.25 gpf (1.0 Lpf) Urinal
	3332016	CR-1014-A	Piston Kit – 0.125 gpf (0.5 Lpf) Urinal

ALL PISTON KITS INCLUDE MAIN SEAT (see item 4 table to right) AND CR-124-A INSIDE COVER ASSEMBLY AS SHOWN IN ITEM 4. PISTON KIT COMPONENTS TABLE TO THE RIGHT.

Item No.	Code No.	Part No.	Description
5A.	0302353	B-30-A	ADA-Compliant Handle Assembly CP
5B.	0302390	B-73-A	ADA-Compliant Handle Assembly CP
6A.	3332006	CR-1007	Handle Repair Kit
6B.	3302306	B-51-A	Handle Repair Kit
7.	5301139	A-31	Handle Gasket – 48/pkg
8.	0302389	B-74-A	Handle Grip Sub-Assembly ADA
9A.	0302309	B-56	Sleeve
9B.	0302109	B-7-A	CP Socket Assembly
10A.	0302354	B-53	Handle Socket
10B.	0301082	A-6	CP Handle Coupling
11.	3393004	V-600-AA	3/4" x 9" (19 x 229 mm) Vacuum Breaker - 6/pkg
	3393006	V-600-AA	1-1/4" x 9" (32 x 229 mm) Vacuum Breaker - 6/pkg
	3393007	V-600-AA	1-1/2" x 9" (38 x 229 mm) Vacuum Breaker - 6/pkg
12.	3323182	V-651-A	High Back Pressure Vacuum Breaker Repair Kit
13.	3332000	CR-1008-A	3/4" (19 mm) Spud Coupling Assembly
	3332001	CR-1009-A	1-1/4" (32 mm) Spud Coupling Assembly
	3332002	CR-1010-A	1-1/2" (38 mm) Spud Coupling Assembly
13A.	<b>SEE SLIP JOINT GASKETS AND RINGS TABLE ON BOTTOM, PAGE 25</b>		
14.	0308676	H-550	Stop Coupling
15.	0308801	H-551-A	Adjustable Tailpiece (2-1/16" (52 mm) long)
16A.	5308696	H-553	O-ring – 24/pkg
16B.	5308381	H-552	Locking Ring – 12/pkg
17.	0388000	H-700-A	1" Screwdriver Bak-Chek® Stop CP
	0388001	H-700-A	3/4" Screwdriver Bak-Chek® Stop CP
18.	3308853	H-541-ASD	Control Stop Repair Kit†
	3308856	H-543-ASD	Control Stop Repair Kit† for 3/4" Stops H-600, H-640
19.	0308612	H-622	CP Bonnet †
	0308843	H-577	CP Bonnet † – <b>OBSELETE</b>
20.	3308840	H-573-A	Locking Vandal Resistant Control Stop Cap includes H-573 Stop Cap CP and H-648 Friction Ring †
	0308848	H-582	Locking Vandal Resistant Control Stop Cap CP †
21.	3308651	H-651	Vandal Resistant Control Stop Cap Assembly †
22.	3308866	H-574	Control Stop Cap w/Bumper (-YO Variation) †
23.	3308867	H-576	Control Stop Cap w/Extended Bumper (-YG Variation)*
—	0305190	EL-190-A	Handle Adapter (manual only) for Optima® version (not shown) to convert to manual

† For use w/H-700-A 1" & 3/4" and H-600-A 1" Screwdriver Bak-Chek® Control Stops.  
‡ For use w/H-600-A 3/4" Screwdriver Bak-Chek® Control Stops.

**ITEM 4. PISTON KIT COMPONENTS**

Item	Code No.	Part No.	Description
A.	0332000	CR-124-A	Inside Cover Sub-Assembly
B.	***	***	Piston Cover
C.	5332095	CR-68-A	Molded Cup – 12/pkg
D.	5328019	SH-406	Spring – 12/pkg
E.	***	***	Relief Valve
F.	0307116	G-95	Relief Valve Seat
G.	***	***	Piston Body
H.	0332013	CR-125-A	Main Seat – 6/pkg (1.0 gpf and 0.5 gpf)
	0332120	CR-167-A	Main Seat – 6/pkg (Water Closets ONLY)
	0332126	CR-170-A	Main Seat – 6/pkg (0.25 gpf and 0.125 gpf)
I.	0307210	G-85	Filter O-ring
J.	0305135	EL-110	O-ring (for use with CR-125-A main seat ONLY)*
	0308958	H-589	O-ring*

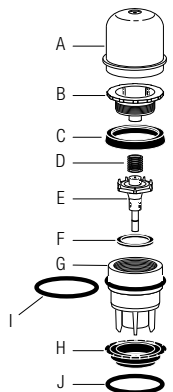

\* Components are NOT interchangeable  
\*\*\* Indicates component is NOT available separately

# Crown® Flushometer Crown® II (Obsolete)

## TROUBLESHOOTING GUIDE

**IMPORTANT:** The CROWN® flushometer is engineered for quiet operation. Excessive water flow creates noise, while too little water flow may not satisfy the needs of the fixture. Proper adjustment is made when plumbing fixture is cleansed after each flush without splashing water out from the lip AND a quiet flushing cycle is achieved.

Never open control stop to where the flow from the valve exceeds the flow capability of the fixture. In the event of a valve failure, the fixture must be able to accommodate a continuous flow from the valve.

**ATTENTION INSTALLERS:** With the exception of the control stop inlet, **DO NOT USE** pipe sealant or plumbing grease on any valve component or coupling! To protect the chrome or special finish of Sloan flushometers, **DO NOT USE** toothed tools to install or service these valves. Use our A-50 Super Wrench or other smooth-jawed wrench to secure couplings. Regulations for low consumption fixtures (1.6 gpf/6.0 Lpf closets and 1.0 gpf/3.8 Lpf urinals) prohibit use of higher flush volumes.

### 1. Valve DOES NOT function.

- A. Control stop or main valve is closed. Open control stop or main valve.
- B. Handle assembly is worn. Install Sloan handle repair kit, or replace handle.
- C. Relief valve is worn and sticking in UP position. Replace piston.

### 2. Insufficient volume of water to adequately siphon fixture.

- A. Control stop not open enough. Adjust control stop for desired delivery of water.
- B. Urinal piston parts inside a closet valve. Replace piston parts with proper closet piston.
- C. Low consumption valve installed on a non-low consumption fixture. Replace with proper flushometer. Crown® flushometers are not available with flush volume higher than 1.6 gpf/6.0 Lpf.
- D. Inadequate volume or pressure at supply. Increase water pressure or supply (flow) to valve. Consult factory for assistance.

### 3. Length of flush too short (short flushing) or valve closes off immediately.

- A. Piston assembly is not hand-tight. Screw the assembly hand-tight.
- B. Enlarged bypass orifice from corrosion or damage. Install NEW inside parts kit to correct problem and update flushometer.
- C. Urinal piston in closet flushometer. Replace piston with proper closet piston.
- D. Low consumption piston installed in non-low consumption fixture. Replace with proper flushometer. Crown® flushometers are not available with flush volume higher than 1.6 gpf (6.0 Lpf).
- E. Handle assembly worn. Install Sloan handle repair kit.

### 4. Length of flush too long (long flushing) or fails to close off.

- A. Piston is not seating properly or bypass orifice is clogged because of foreign material, or bypass orifice is clogged by an invisible gelatinous film from "over-treated" water. Disassemble the working parts and wash thoroughly. *NOTE: Size of the orifice in the bypass is of utmost importance for the proper metering of water into the upper chamber of the valve. DO NOT enlarge or damage this orifice.* Replace piston if cleaning does not correct problem.
- B. Line pressure has dropped and is not sufficient to force relief valve to seat. Shut off all control stops until pressure has been restored, then open them again.
- C. Main seat is fouled with debris or is worn. Clean or replace main seat.

### 5. Leaking at handle assembly.

- A. The B-85 seal may have deteriorated. Install new B-85 seal. *NOTE: The B-85 seal will easily slide onto the bushing if it is wet.*
- B. Handle gasket has been omitted. Install A-31 handle gasket or Sloan handle repair kit.
- C. Valve handle bushing is worn. Install Sloan handle repair kit.

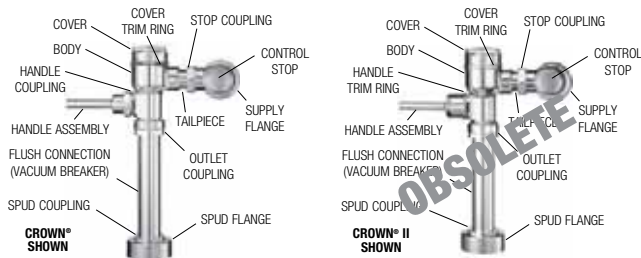

## CARE AND CLEANING

**DO NOT USE** abrasive or chemical cleaners (including chlorine bleach) to clean flushometers that may dull the luster and attack the chrome or special decorative finishes. Use **ONLY** mild soap and water, then wipe dry with clean cloth or towel.

While cleaning the bathroom tile, the flushometer should be protected from any splattering of cleaner. Acids and cleaning fluids will discolor or remove chrome plating.

**When assistance is required, please contact Sloan Technical Support at: 1-888-SLOAN-14 (1-888-756-2614).**

Piston Identification Chart	Water Closet		Urinal			
	CR-1004-A	CR-1011-A	CR-1005-A	CR-1006-A	CR-1015-A	CR-1014-A
3332003	3332013	3332004	3332004	3332017	3332016	
1.6 gpf (6.0 Lpf)	1.28 gpf (4.8 Lpf)	1.0 gpf (3.8 Lpf)	0.5 gpf (1.9 Lpf)	0.25 gpf (1.0 Lpf)	0.125 gpf (0.5 Lpf)	
<b>Cap Color</b>	Green	Deep Purple	Yellow	Red	Burgundy	Pink
<b>Piston Color</b>	Green	Green	Clear	Clear	Burgundy	Burgundy
<b>Barrel</b>	Large Ribs	Large Ribs	Small Ribs	Small Ribs	-	-
<b>Seat Color</b>	Green	Green	Black	Black	Burgundy	Burgundy
<b>Grooves</b>	2	0	1	3	1	3

# Gem•2® Flushometer

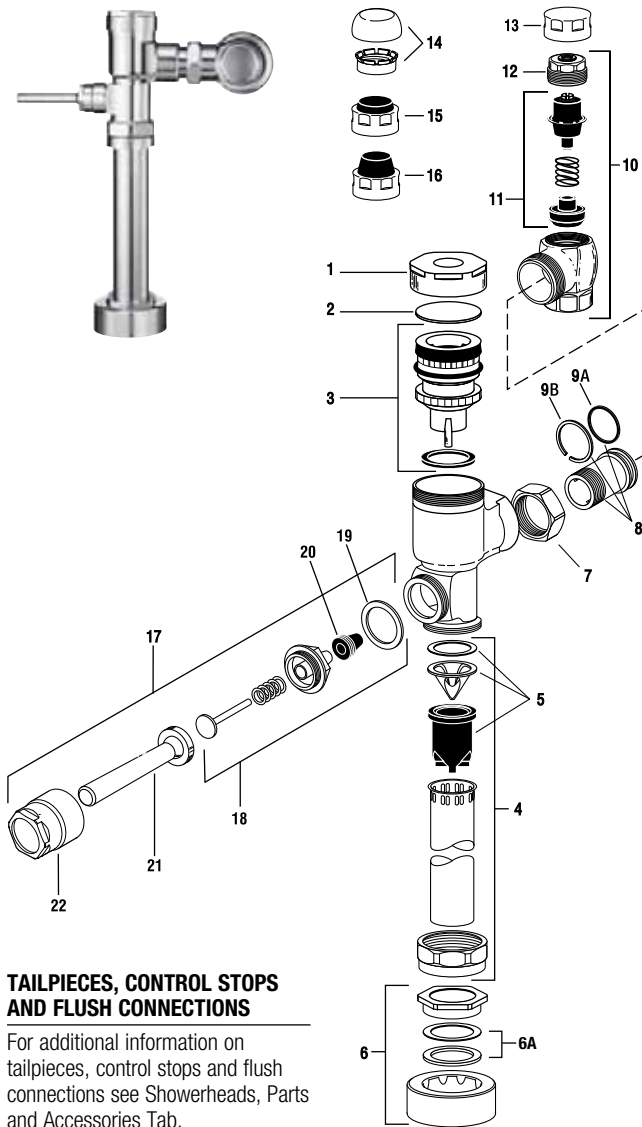

### TAILPIECES, CONTROL STOPS AND FLUSH CONNECTIONS

For additional information on tailpieces, control stops and flush connections see Showerheads, Parts and Accessories Tab.

### ITEM 6A. SLIP JOINT GASKETS AND RINGS

Size	Code No.	Part No.	Description
1-1/2"	5306058	F-3	Red Friction Ring
	5322001	VPF-5	Black Slip Joint Gasket
	0319086/5319086	S-30	Flexible Seat
	0319079	S-21	Rigid Seat (rubber over brass)
1-1/2" x 1-1/4"	0396062	F-105	Slip Joint Gasket – Rigid
1-1/4"	5306057	F-3	Red Friction Ring
	5322176	VPF-5	Black Slip Joint Gasket
	0307052/5307052	G-21	Rigid Seat (rubber over brass)
1"	5306056	F-3	Red Friction Ring
	5306115	F-5	Black Slip Joint Gasket
3/4"	5306055	F-3	Red Friction Ring
	5306113	F-5	Black Slip Joint Gasket

### PARTS LIST

Item No.	Code No.	Part No.	Description
1.	0307142	G-105	CP Cover
2.	0307139	G-106	Slip Disc
3.	3307135	G-1022-A	Piston Kit – 1.28 gpf/4.8 Lpf Water Closet
	0307193	G-1007-A	Piston Kit – 3.5 gpf/13.2 Lpf Water Closet
	0307195	G-1016-A	Piston Kit – 1.6 gpf/6 Lpf Water Closet
	0307192	G-1009-A	Piston Kit – 1.5 gpf/5.7 Lpf Urinal
	0307185	G-1017-A	Piston Kit – 1.0 gpf/3.8 Lpf Urinal
	3307133	G-1018-A	Piston Kit – 0.5 gpf/1.9 Lpf Urinal
	3307134	G-1019-A	Piston Kit – 2.4 gpf/9.0 Lpf Water Closet
<b>PISTON KITS FOR OLD STYLE ADJUSTABLE GEM FLUSHOMETERS</b>			
	0307043	G-1003-A	Piston Kit – Water Closet
	0307044	G-1002-A	Piston Kit – Urinal
<b>ALL PISTON KITS INCLUDE G-21 MAIN SEAT (See next page)</b>			
4.	5323005	V-500-AA	3/4" x 9" Vacuum Breaker – 6 per package
	5323006	V-500-AA	1-1/4" x 9" Vacuum Breaker – 6 per package
	5323007	V-500-AA	1-1/2" x 9" Vacuum Breaker – 6 per package
5.	3323192	V-551-A	Vacuum Breaker Repair Kit
6.	3332002	CR-1010-A	1-1/2" (38 mm) Spud Coupling
	3332001	CR-1009-A	1-1/4" (32 mm) Spud Coupling
	3332000	CR-1008-A	3/4" (19 mm) Spud Coupling
6A.	<b>SEE SLIP JOINT GASKETS AND RINGS TABLE BELOW LEFT</b>		
7.	0308676	H-550	Stop Coupling
8.	0308801	H-551-A	Adjustable Tailpiece 2-1/16" (Standard Length)
9A.	5308696	H-553	O-ring – 24 per package
9B.	5308381	H-552	Locking ring – 12 per package
10.	0388022	H-710-A	1" Screwdriver Bak-Chek® Stop CP – complete
	0388025	H-710-A	3/4" Screwdriver Bak-Chek® Stop CP – complete
11.	3308853	H-541-A	Control Stop Repair Kit*
	3308856	H-543-A	Control Stop Repair Kit**
12.	0308612	H-622	CP Bonnet*
	0308843	H-577	CP Bonnet** – <b>OBSOLETE</b>
13.	3308840	H-573-A	Control Stop Cap CP*
	0308848	H-582	Control Stop Cap CP**
14.	3308791	H-1010-A	Vandal Resistant Control Stop Cap Assembly*
	3308790	H-1009-A	Vandal Resistant Control Stop Cap Assembly**
15.	3308866	H-574	Control Stop Cap w/Bumper (-YO Variation)*
16.	3308867	H-576	Control Stop Cap w/Extended Bumper (-YG Variation)*
<b>HANDLE REPAIR KIT</b>			
17.	0307100	G-143	Handle Assembly
18.	5307074	G-50-A	Handle Repair Kit – 6 per package
19.	5307065	G-35	Handle Gasket – 48 per package
20.	5302297	B-39	Handle Seal – 12 per package
21.	0307024	G-145	Handle Grip
22.	0307020	G-144	Handle Socket

\*For use with 1" and 3/4" H-700-A and 1" H-600-A Bak-Chek® screwdriver control stop

\*\*For use with 3/4" H-600-A Bak-Chek® screwdriver control stop

# Gem•2® Flushometer

Manual  
Flushometers

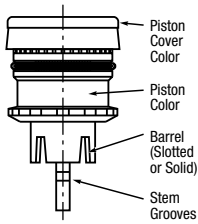

Gem•2 Pistons can be identified by the color, shape and marking of the above components.

### ITEM 3. PISTON KITS

Code No.	Part No.	Description	Cover Color	Piston Color	Barrel	Grooves
0307193	G-1007-A	3.5 gpf (13.2 Lpf) – Water Closet	White	Gray	Slotted	2
0307195	G-1016-A	1.6 gpf (6.0 Lpf) – Water Closet	Green	Black	Slotted	2*
0307192	G-1009-A	1.5 gpf (5.7 Lpf) – Urinal	Black	Black	Solid	2
0307185	G-1017-A	1.0 gpf (3.8 Lpf) – Urinal	Yellow	Black	Solid	1
3307133	G-1018-A	0.5 gpf (1.8 Lpf) – Urinal	Red	Black	Solid	3
3307134	G-1019-A	2.4 gpf (9.0 Lpf) – Water Closet	Blue	Gray	Slotted	0
3307135	G-1022-A	1.28 gpf (4.8 Lpf) – Water Closet	Deep Purple	Black	Slotted	0

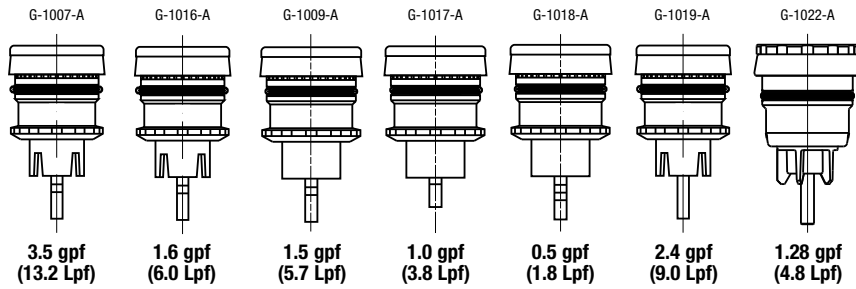

\*Prior to February 2006-1 Groove

### ITEM 3. PISTON COMPONENTS

Item	Code No.	Part No.	Description
A.	***	***	Piston Cover
B.	5307106	G-78	Molded Cup – 12 per package
C.	0307130	G-102	Spring
D.	***	***	Relief Valve
E.	0307116	G-95	Relief Valve Seat
F.	***	***	Piston Body
G.	0307210	G-85	Filter O-ring
H.	5307052	G-21	Main Seat – 6 per package

### REPAIR KIT

Code No.	Part No.	Description
3307128	G-1011-A	Repair Kit includes Items: 2, 6, 7, B, C, E, G & H

For old style adjustable GEM flushometers use kit: G-1005-A  
 \*\*\* Indicates component is NOT available separately

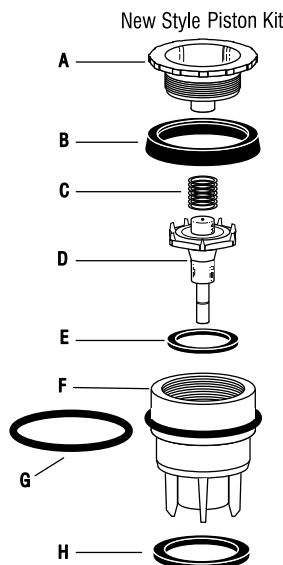
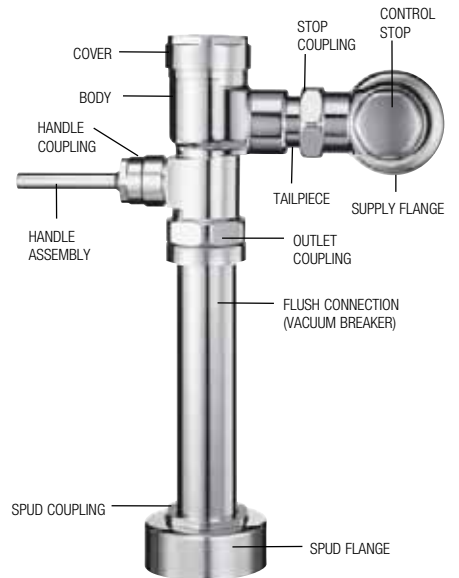

## Gem•2® Flushometer

### REPAIR PARTS FOR OLD STYLE GEM FLUSHOMETERS (PRE-1985) Adjustable Cover

Item No.	Code No.	Part No.	Description
1.	—	G-24	CP Cover Screw – <b>OBSOLETE</b>
2.	—	G-23	CP Cover – <b>OBSOLETE</b>
	—	G-26	CP Cover for Bumper – <b>OBSOLETE</b>
3.	—	G-27	Bumper (12 per package) – <b>OBSOLETE</b>
4.	<b>0307058</b>	G-25	Cover Gasket (12 per package)
5.	—	G-4	RB Inside Cover – <b>OBSOLETE</b>
6.	—	G-6	RB Regular Screw – <b>OBSOLETE</b>
7.	—	S-26	Packing
8.	—	S-24	Packing Disc
9.	—	G-10	RB Packing Nut – <b>OBSOLETE</b>
10.	—	G-65	Gasket – <b>OBSOLETE</b>
11.	—	G-5	Gasket

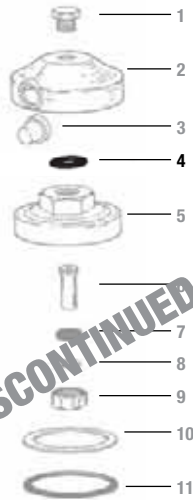

### SPUD COUPLING FOR OLD STYLE GEM FLUSHOMETERS (PRE-MAY, 2003)

Item No.	Code No.	Part No.	Description
1.	<b>0306125</b>	F-5-A	3/4" Spud Coupling
	<b>0305140</b>	F-5-A	1-1/4" Spud Coupling
	<b>0306146</b>	F-5-A	1-1/2" Spud Coupling

1A. SEE SLIP JOINT GASKETS AND RINGS TABLE ON BOTTOM, PAGE 30

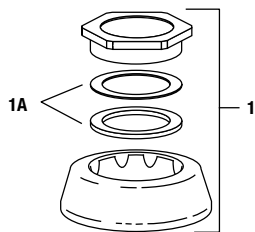

### HANDLE ASSEMBLY FOR OLD STYLE GEM FLUSHOMETERS (PRE-MAY, 2003)

Item No.	Code No.	Part No.	Description
1.	<b>0307100</b>	G-143-A	Handle Assembly – 6 per package
2.	<b>5307074</b>	G-50-A	Handle Repair Kit – 6 per package
3.	<b>5307065</b>	G-35	Handle Gasket – 48 per package
4.	<b>5302297</b>	B-39	Handle Seal – (12 per package)
5.	—	G-36	Handle Grip
6.	—	G-28	Handle Socket

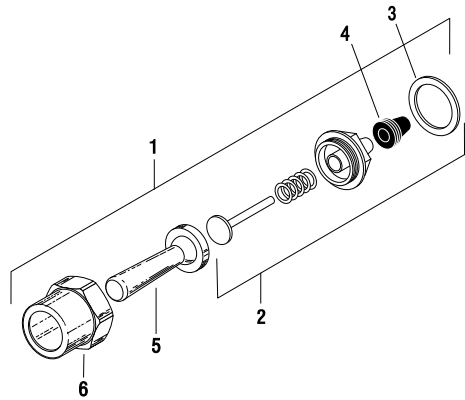

### REPAIR PARTS FOR OLD STYLE PISTON

Item No.	Code No.	Part No.	Description
12.	<b>0307105</b>	G-77	Piston Cover
13.	<b>0307106</b>	G-78	Molded Cup
14.	<b>0307113</b>	G-84	Spring
15.	<b>0307110</b>	B-81-A	Relief Valve
16.	<b>0307112</b>	G-83	Relief Valve Seat
17.	—	G-75	Closet Piston Body
	—	G-76	Urinal Piston Body
18.	<b>0307052</b>	G-21	Main Seat

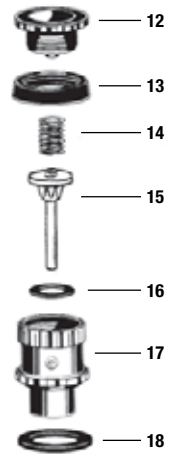

### PISTON KITS FOR OLD STYLE ADJUSTABLE GEM VALVES

Code No.	Part No.	Description	Piston Color	Barrel	Grooves
<b>0307044</b>	G-1002-A	Urinal	Black	Solid	0
<b>0307043</b>	G-1003-A	Water Closet	Black	Slotted	0

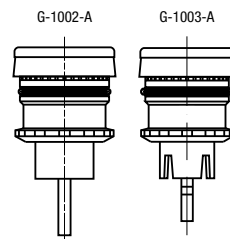

## Gem•2® Flushometer

### TROUBLESHOOTING GUIDE

**IMPORTANT:** The GEM flushometer is engineered for quiet operation. Excessive water flow creates noise, while too little water flow may not satisfy the needs of the fixture. Proper adjustment is made when plumbing fixture is cleansed after each flush without splashing water out from the lip AND a quiet flushing cycle is achieved.

Never open Control Stop to where the flow from the valve exceeds the flow capability of the fixture. In the event of a valve failure, the fixture must be able to accommodate a continuous flow from the valve.

**ATTENTION INSTALLERS:** With the exception of the control stop inlet, **DO NOT USE** pipe sealant or plumbing grease on any valve component or coupling! To protect the chrome or special finish of Sloan flushometers, **DO NOT USE** toothed tools to install or service these valves. Use our A-50 Super Wrench or other smooth-jawed wrench to secure couplings. Regulations for low consumption fixtures (1.6 gpf/6.0 Lpf closets and 1.0 gpf/3.8 Lpf urinals) prohibit use of higher flush volumes.

#### 1. Valve DOES NOT function.

- A. Control stop or main valve is closed. Open control stop or main valve.
- B. Handle assembly is worn. Install handle repair kit G-50-A or replace handle.
- C. Relief valve is worn and sticking in UP position. Replace piston.

#### 2. Insufficient volume of water to adequately siphon fixture.

- A. Control stop not open enough. Adjust control stop for desired delivery of water.
- B. Urinal piston parts inside a closet valve. Replace piston parts with proper closet piston.
- C. Low consumption valve installed on a non-low consumption fixture. Replace with proper piston kit.
- D. Inadequate volume or pressure at supply. Increase water pressure or supply (flow) to valve. Consult factory for assistance.

#### 3. Length of flush too short (short flushing) or valve closes off immediately.

- A. Piston assembly is not hand-tight. Screw the assembly hand-tight.
- B. Enlarged bypass orifice from corrosion or damage. Install NEW inside parts kit to correct problem and update flushometer.
- C. Urinal piston in closet flushometer. Replace piston with proper closet piston.
- D. Low consumption piston installed in non-low consumption fixture. Replace with proper piston kit.
- E. Handle assembly worn. Install handle repair kit G-50-A.

#### 4. Length of flush too long (long flushing) or fails to close off.

- A. Piston is not seating properly or bypass orifice is clogged because of foreign material, or bypass orifice is clogged by an invisible gelatinous film from "over-treated" water. Disassemble the working parts and wash thoroughly. **NOTE:** Size of the orifice in the bypass is of utmost importance for the proper metering of water into the upper chamber of the valve. **DO NOT** enlarge or damage this orifice. Replace piston if cleaning does not correct problem.
- B. Line pressure has dropped and is not sufficient to force relief valve to seat. Shut off all control stops until pressure has been restored, then open them again.
- C. 3.5 gpf closet piston has been used in a 1.0 or 1.5 gpf urinal or on a 1.6 gpf toilet. Replace with proper piston.
- D. G-21 main seat is fouled with debris or is worn. Clean or replace main seat.

#### 5. Leaking at handle assembly.

- A. The B-39 seal may have deteriorated. Install new B-39 seal. **NOTE:** The seal will easily slide right onto the bushing if it is wet.
- B. Handle gasket has been omitted. Install G-35 handle gasket or Sloan handle repair kit G-50-A.
- C. Valve handle bushing is worn. Install Sloan handle repair kit G-50-A.

### CARE AND CLEANING

**DO NOT USE** abrasive or chemical cleaners to clean flushometers as they may dull the luster and attack the chrome or special decorative finishes. Use **ONLY** mild soap and water, then wipe dry with clean cloth or towel.

While cleaning the bathroom tile, the flushometer should be protected from any splattering of cleaner. Acids and cleaning fluids can discolor or remove chrome plating.

**When assistance is required, please contact Sloan Technical Support at: 1-888-SLOAN-14 (1-888-756-2614).**

**Naval® Flushometer**

Also for use with Crown® (Old style), Star and Marine

Manual Flushometers

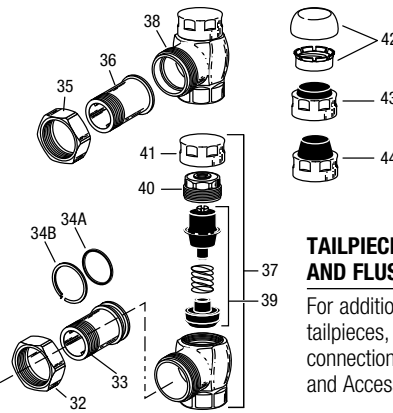
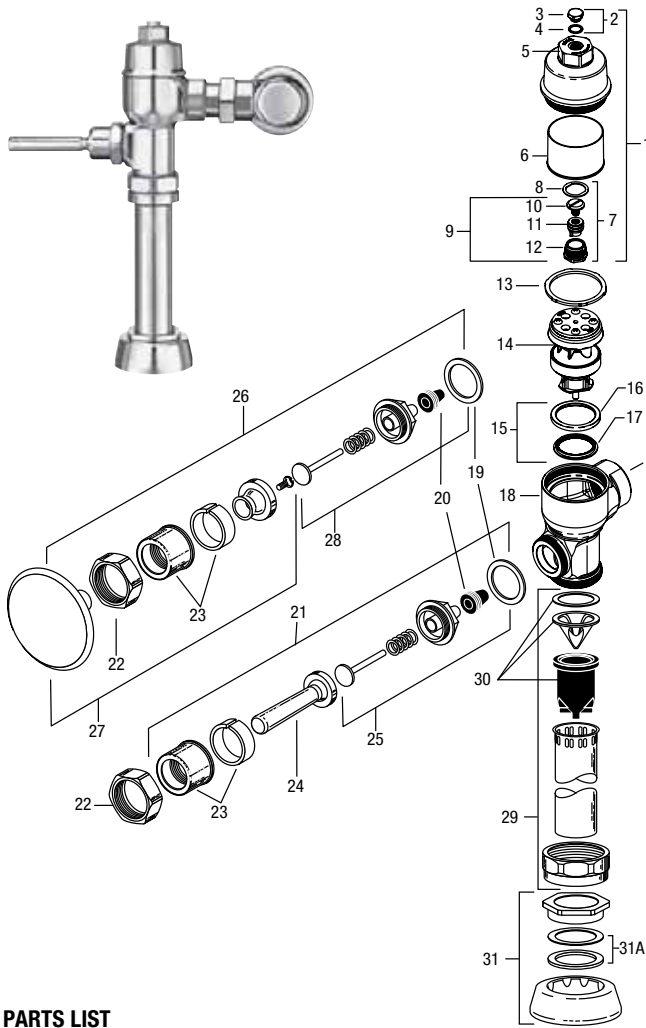

**TAILPIECES, CONTROL STOPS AND FLUSH CONNECTIONS**

For additional information on tailpieces, control stops and flush connections see Showerheads, Parts and Accessories Tab.

**PARTS LIST**

Item No.	Code No.	Part No.	Description
1.	<b>0314229</b>	CN-86-A	Cover Assembly CP
	<b>0314310</b>	CN-89-A	Cover Assembly CP One Pint* 1.6 gpf/6.0 Lpf, 1.0 gpf/3.8 Lpf
2.	<b>5314010</b>	CN-1007-A	Cap Screw Repair Kit – 6 per package
3.	<b>0314208</b>	CN-36	Cover Screw CP
4.	<b>0314209</b>	CN-30	Cover Screw Gasket
5.	<b>0314304</b>	CN-84	Cover
6.	<b>0214019</b>	CN-55	Cover Liner
7.	<b>3314015</b>	CN-1008-A	Regulating Screw Repair Kit**
8.	<b>0314303</b>	CN-81	Volume Adjustment Gasket
9.	<b>0314315</b>	CN-88-A	Low Consumption Volume Adjustment Sleeve Sub-Assembly 1.6 gpf/6.0 Lpf, 1.0 gpf/3.8 Lpf
10.	<b>0314302</b>	CN-80	Volume Adjustment Screw
11.	<b>0314300</b>	CN-78	Volume Adjustment Sleeve
	<b>0314307</b>	CN-87	Volume Adjustment Sleeve One Pint***
12.	<b>0314301</b>	CN-79	Volume Adjustment Housing
13.	<b>5314243</b>	CN-76	Cover Gasket – 12 per package
14.	<b>0314016</b>	CN-1002-A	Piston – Closet
	<b>0314017</b>	CN-1003-A	Piston – Urinal
15.	<b>0314234</b>	CN-21-A	Main Seat Assembly
16.	<b>0314224</b>	CN-111-A	Main Seat
17.	<b>0314220</b>	CN-113	Main Seat Ring
18.	<b>0314020</b>	CN-3	Body CP (Not sold separately)
19.	<b>5301139</b>	A-31	Handle Gasket – 48 per package

Item No.	Code No.	Part No.	Description
20.	<b>5302297</b>	B-39	Handle Seal – 12 per package
21.	<b>0302390</b>	B-73-A	Triple Seal Handicap Handle Assembly (ADA Compliant)
22.	<b>0301082</b>	A-6	Handle Coupling CP
23.	<b>0302109</b>	B-7-A	Socket Assembly CP
24.	<b>0302389</b>	B-74-A	Handicap Handle Grip CP (ADA Compliant)
25.	<b>3302306</b>	B-51-A	Triple Seal Handle Repair Kit – 1 per package
26.	<b>0303351</b>	C-42-A	3" Push Button Assembly CP
27.	<b>3303347</b>	C-1000-A	3" Push Button Replacement Kit
28.	<b>3303396</b>	C-64-A	3" Push Button Repair Kit
29.	<b>5323005</b>	V-500-A	3/4" x 9" Vacuum Breaker
	<b>5323006</b>	V-500-A	1-1/4" x 9" Vacuum Breaker
	<b>5323007</b>	V-500-A	1-1/2" x 9" Vacuum Breaker
30.	<b>3323192</b>	V-551-A	Vacuum Breaker Repair Kit
31.	<b>0306125</b>	F-5-AW	3/4" Spud Coupling CP
	<b>0306140</b>	F-5-AU	1-1/4" Spud Coupling CP
	<b>0306146</b>	F-5-AT	1-1/2" Spud Coupling CP
31A.	<b>SEE SLIP JOINT GASKETS AND RINGS TABLE ON BOTTOM, PAGE 30</b>		
32.	<b>0308676</b>	H-550	Stop Coupling CP
33.	<b>0314289</b>	NH-551-A	Adjustable Tailpiece 2-1/16" CP
34A.	<b>5308696</b>	H-553	O-ring – 24 per package
34B.	<b>5308381</b>	H-552	Locking ring – 12 per package
35.	<b>0308063</b>	H-6	Ground Joint Stop Coupling CP
36.	<b>0314028</b>	NH-5	Ground Joint Tailpiece 1-5/8"
37.	<b>0388022</b>	H-710-A	1" Adjustable Tailpiece SD Bak-Chek® Control Stop CP
	<b>0388025</b>	H-710-A	3/4" Adjustable Tailpiece SD Bak-Chek® Control Stop CP
38.	<b>0388024</b>	H-710-AG	1" Ground Joint Screwdriver Bak-Chek® Control Stop CP
	<b>0388026</b>	H-710-AG	3/4" Ground Joint Screwdriver Bak-Chek® Control Stop CP
39.	<b>3308853</b>	H-541-A	Control Stop Repair Kit †
	<b>3308856</b>	H-543-A	Control Stop Repair Kit †
40.	<b>0308612</b>	H-622	Bonnet CP †
	<b>0308843</b>	H-577	Bonnet CP † – <b>OBSOLETE</b>
41.	<b>0308840</b>	H-573	Control Stop Cap CP †
	<b>0308848</b>	H-582	Control Stop Cap CP †
42.	<b>3308772</b>	H-1010-A	Vandal Resistant Stop Cap Assembly †
	<b>3308790</b>	H-1009-A	Vandal Resistant Stop Cap Assembly †
43.	<b>3308866</b>	H-574	Control Stop Cap with Bumper †
44.	<b>3308867</b>	H-576	Control Stop Cap with Extended Bumper†

\* Use CN-89-A Cover Assembly One-Pint for reduced flush volumes 1.6 gpf/6.0 Lpf, 1.0 gpf/3.8 Lpf

\*\* CN-1008-A Regulating Screw Repair Kit contains the parts shown plus the parts for old style adjusting screw as currently shown on the repair guide (CN-24, CN-25, CN-26, CN-61)

\*\*\* Use CN-87 Volume Adjustment Sleeve One-Pint for reduced flush volumes

† For use with 1" and 3/4" H-740-A-CP (less cap) and 1" H-540-A-CP (w/H-37 cap) Bak-Chek® screwdriver control stops

‡ For use with 3/4" H-740-A-CP Bak-Chek® screwdriver control stops

# Naval® Flushometer

Also for use with Crown® (Old style), Star and Marine

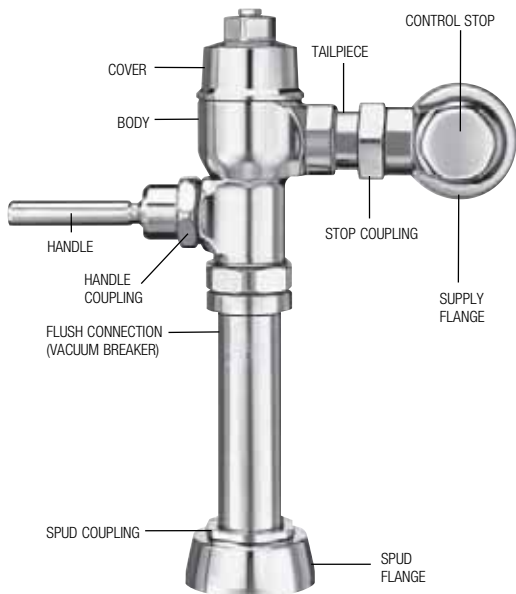
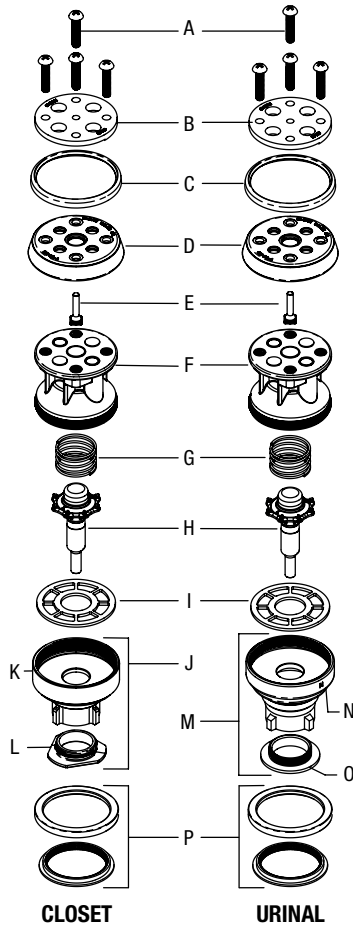

### NAVAL PISTON COMPONENTS (Items 14 thru 17 on previous page)

Item	Code No.	Part No.	Description
A.	0314200	CN-17	Top Plate Screws – 24 per package
B.	0314082	CN-15	Top Plate
	0314179	CN-15-A	Top Plate – Shower Valve only
C.	0314314	CN-92	Support Cup Lip Seal
D.	5314188	CN-68-A	Single Lip Cup – 12 per package
E.	0314204	CN-57	Xpelor
F.	0314228	CN-160	Piston Body
G.	5328019	SH-406	Spring – 12 per package (Replaces S/CN-58 Safety Bar)
H.	0314078	CN-18-A	Relief Valve
I.	5314226	CN-120	Relief Valve Seat – 12 per package
J.	0314240	CN-123-AC	Guide Assembly – Closet
K.	0314231	CN-23	Guide – Closet
L.	0314237	CN-144	Restriction Ring – Closet
M.	0314242	CN-123-AU	Guide Assembly – Urinal
N.	0314189	CN-43	RC Guide – Urinal
O.	—	CN-45	NK Restriction Ring – Urinal
P.	0314234	CN-21-A	Main Seat
	0314223	CN-121-A	Main Seat – Shower Valve only

NOTE: Naval® pistons can be used to replace pistons in older Crown® and Star flushometers.

### REPAIR KITS

Code No.	Part No.	Description
0314016	CN-1002-A	Piston with Main Seat – Closet
0314017	CN-1003-A	Piston with Main Seat – Urinal
5314094	CN-1004-A	Piston Rebuild Kit – Closet & Urinal – 6 per package includes: 13, A, B, C, D, E, I, K, Cap Screw Gasket & Regulating Screw Packing
5314184	CN-1006-A	Piston Rebuild Kit – Shower – 6 per package includes: 13, A, B, C, D, E, I, K, Cap Screw Gasket & Regulating Screw Packing
5314184	CN-1008-A	Regulating Screw Repair Kit – includes: 2, 8, 9, CN-24 Packing Disc, CN-25 Packing Gland, CN-26 Packing Regulating Screw, CN-61 Screw Regulating Stable Piston
0314191	CN-1009-A	Piston with Main Seat – Shower
5314050	CN-1010-A	Crown®/Naval® Valve Washer Set – 6 per package includes: 13, 19, 20, C, D, I, K, Cap Screw Gasket & Regulating Screw Packing
5319049	S-14-AA	Double Cup Repair Kit (Old style Crown, Star and Marine)
5319046	S-14-A	Double Cup Lip Seal only (Old style Crown, Star and Marine)

### ITEM 31A. SLIP JOINT GASKETS AND RINGS

Size	Code No.	Part No.	Description
1-1/2"	5306058	F-3	Red Friction Ring
	5322001	VBF-5	Black Slip Joint Gasket
	0319086/5319086	S-30	Flexible Seat
	0319079	S-21	Rigid Seat (rubber over brass)
1-1/2" x 1-1/4"	0396062	F-105	Slip Joint Gasket – Rigid
1-1/4"	5306057	F-3	Red Friction Ring
	5322176	VBF-5	Black Slip Joint Gasket
	0307052/5307052	G-21	Rigid Seat (rubber over brass)
1"	5306056	F-3	Red Friction Ring
	5306115	F-5	Black Slip Joint Gasket
3/4"	5306055	F-3	Red Friction Ring
	5306113	F-5	Black Slip Joint Gasket

**Naval® Flushometer**

Also for use with Crown® (Old style), Star and Marine

**TROUBLESHOOTING GUIDE**

**IMPORTANT:** The NAVAL® flushometer is engineered for quiet operation. Excessive water flow creates noise, while too little water flow may not satisfy the needs of the fixture. Proper adjustment is made when plumbing fixture is cleansed after each flush without splashing water out from the lip AND a quiet flushing cycle is achieved.

Never open Control Stop to where the flow from the valve exceeds the flow capability of the fixture. In the event of a valve failure, the fixture must be able to accommodate a continuous flow from the valve.

**ATTENTION INSTALLERS:** With the exception of the control stop inlet, DO NOT USE pipe sealant or plumbing grease on any valve component or coupling! To protect the chrome or special finish of Sloan flushometers, DO NOT USE toothed tools to install or service these valves. Use our A-50 Super-Wrench™ or other smooth-jawed wrench to secure couplings. Regulations for low consumption fixtures (1.6 gpf/6.0 Lpf closets and 1.0 gpf/3.8 Lpf urinals) prohibit use of higher flush volumes.

**NOTE:** In all piston variations the SH-406 spring has replaced the "U" bar. In all piston variations the CN-68-A single lip cup has replaced the S-14-A double lip cup. When rebuilding a piston, install the CN-68-A single lip cup with the cup facing down.

**1. Valve DOES NOT function.**

- A. Control stop or main valve closed. Open control stop or main valve.
- B. Handle assembly is worn. Install handle repair kit B-51-A or replace handle.

**2. Insufficient volume of water to adequately siphon fixture.**

- A. Control stop not open enough. Adjust control stop for desired delivery of water.
- B. Urinal or shower piston installed in a closet valve or older blow out urinal. Replace piston with proper closet piston (see item 4).
- C. Regulating screw (on top of valve) not at proper setting. Turn regulating screw counterclockwise to increase flush. Adjustment range: urinal – 0.5 to 3 gpf (1.9 to 11.4 Lpf); closet – 1.5 to 7 gpf (5.7 to 26.5 Lpf).
- D. Piston worn out. Repair or replace piston.
- E. Inadequate volume or pressure at supply. If no gauges are available to properly measure supply pressure or volume of water at the valve, then completely remove the entire piston from the valve, reassemble cover and open control stop to allow water to pass through empty valve. If the supply is adequate to siphon the fixture, remove the flow ring from the bottom of the piston to provide additional flow. If the supply is not adequate to siphon the fixture, steps should be taken to increase the pressure and/or supply.

**3. Length of flush too short (short flushing) or valve closes off immediately.**

- A. Regulating screw not at a proper setting. Turn regulating screw counterclockwise to lengthen flush.
- B. Water passing by damaged or worn piston cup. Repair or replace piston.
- C. Loose piston assembly or loose top plate screw. Tighten top plate screws. Screw piston body and guide together (hand tighten ONLY – rubber relief valve seat will distort if screwed too tight).
- D. Damaged or worn piston top plate or expelor. Repair or replace piston.
- E. Urinal or shower piston installed in a closet valve or older blow out urinal. Replace piston with closet piston CN-1002-A.

**4. Length of flush too long (long flushing) or fails to close off.**

- A. Regulating screw not at proper setting. Turn regulating screw clockwise to shorten flush.
- B. Relief valve in piston is not seating properly due to wear or debris. Disassemble piston assembly and wash under running water. Repair or replace piston if necessary.
- C. Bypass holes in piston or top plate clogged or fouled with debris. Disassemble piston assembly and wash under running water. Repair or replace piston if necessary.
- D. Closet piston installed in urinal valve. Replace piston with urinal piston CN-1003-A.
- E. Line water pressure has dropped and is not sufficient to force relief valve to seat. Shut off control stop until pressure has been restored, then reopen stop.

**5. Water splashes from fixture.**

- A. Supply volume is more than necessary. Adjust control stop to meet flow rate required for proper cleansing of fixture.
- B. Lime or mineral accumulation on fixture vortex or spreader holes. Remove lime or mineral build-up in fixture.

**6. Flush is not considered "quiet" or makes noise at close off.**

- A. Control stop not properly adjusted. Adjust control stop to meet flow rate required for proper cleansing of the fixture.
- B. Worn, damaged or loose main seat. Replace main seat.
- C. Worn piston. Repair or replace piston.

**7. Leaking at handle assembly.**

- A. The B-39 handle seal may be deteriorated. Install new B-39 handle seal. *NOTE: The B-39 seal will easily slide right onto the bushing if it is wet.*
- B. Handle gasket has been omitted. Install A-31 handle gasket or handle repair kit B-51-A.
- C. Valve handle bushing is worn. Install handle repair kit B-51-A.

**CARE AND CLEANING INSTRUCTIONS**

**DO NOT USE** abrasive or chemical cleaners to clean flushometers that may dull the luster and attack the chrome or special decorative finishes. Use **ONLY** mild soap and water, then wipe dry with clean cloth or towel.

While cleaning the bathroom tile, protect the flushometer from any splattering of cleaner. Acids and cleaning fluids can discolor or remove chrome plating.

**When assistance is required, please contact**

**Sloan Technical Support at: 1-888-SLOAN-14 (1-888-756-2614).**

## Dolphin® Flushometer

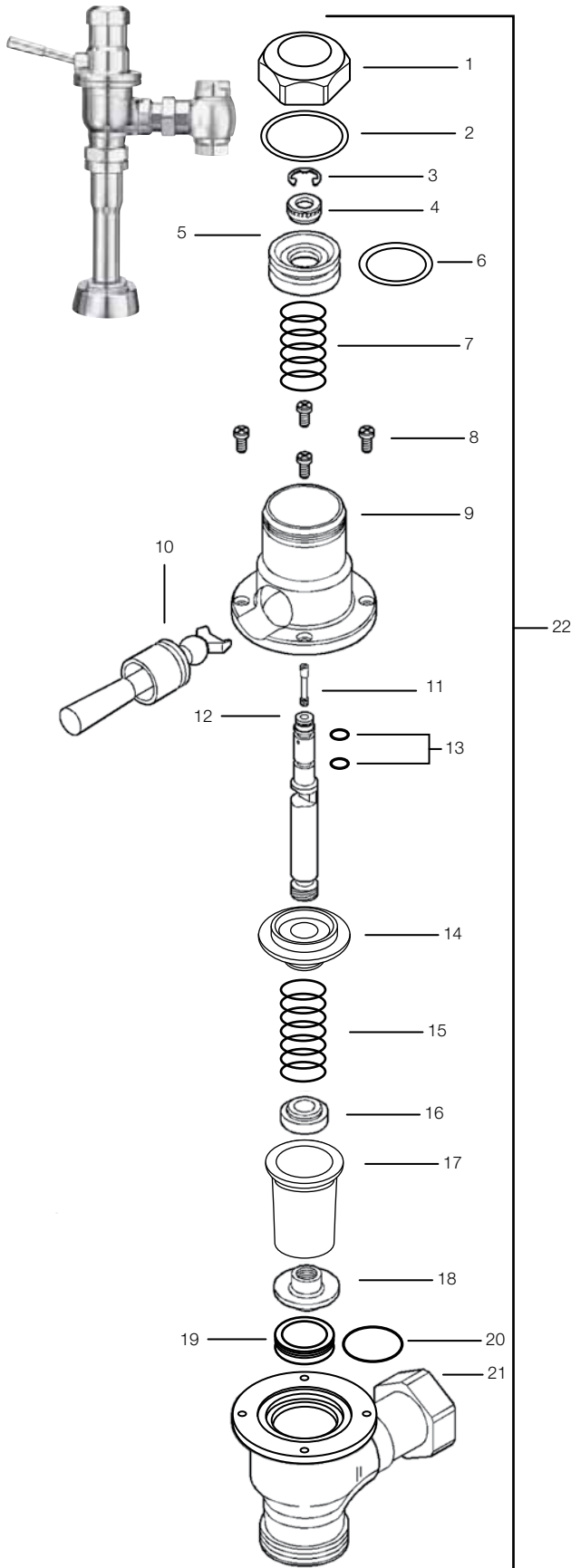

### PARTS LIST—DOLPHIN® FLUSHOMETER

Item No.	Code No.	Part No.	Description
1.	0337007	DO-1	Cover Nut CP
2.	5337125	DO-2	O-ring-Seat – 1 required – 6 per package (Cover Gasket)
3.	5337129	DO-28	Retaining Ring – 1 required – 24 per package
4.	5337006	DO-4	Stem Nut RB – 1 required – 6 per package
5.	0337004	DO-5	Piston
6.	5337075	DO-6	O-ring-Piston – 1 required – 6 per package
7.	5337039	DO-7	Piston Spring – 1 required – 6 per package
8.	5337011	DO-11	Cover Screw CP – 4 required – 24 per package
9.	0337003	DO-10	Upper Body CP
10.	0337042	DO-20	Handle and Socket Assembly CP
	0337012	DO-26	Socket
11.	5337126	DO-3	Regulating Screw RB – 1 required – 6 per package
12.	0337087	DO-9	Stem RB
13.	0328336	SH-75	O-ring-Throttle Seal (2 required)
14.	0337005	DO-14	Bushing RB
15.	0337009	DO-16	Compression Spring (Main Spring)
16.	5337034	DO-17	Insert RB – 1 required – 6 per package
17.	0337018	DO-15	“Flex-Sac”
18.	0337084	DO-18	Seating Nut. Part of DO-32 “Flex-Sac” Assembly (See below)
19.	0337016	DO-19	Seat Assembly w/O-ring
20.	0337086	DO-22	O-ring
21.	0337031	DO-13-NC	Lower Body CP-Closet
	0337032	DO-13-NU	Lower Body CP-Urinal
22.	—	DO-90-AA	Complete Body Assembly
	—	DO-90-AAG	Complete Body Assembly
	—	DO-90-AAU	Complete Body Assembly

### REPLACEMENT AND REPAIR KITS

A.	0337044	DO-1000-A	Piston w/ o-ring. Component parts: Items 5 and 6
B.	3337035	DO-1001-A	Repair Kit-Dolphin Handle Component parts: Items 10, 11, 12, and 13
C.	0337134	DO-32	Flex-Sac Assembly Component parts: Items 17 and 18
D.	0337136	DO-32-AA	Repair Kit-“Flex-Sac” Assembly. Component parts: Items 2, 6, 13, 17, and 18
E.	0337137	DO-32-AAN	Repair Kit-“Flex-Sac” and Stem. Component parts: Items 2, 6, 7, 13, 15, 17, 18, 19, and 20
F.	0337036	DO-19-A	Seat Assembly w/ o-ring Component parts: Items 19 and 20
G.	0337030	DO-12-A	Upper Body Assembly. Component parts: Items 1 through 7 and 9 through 18
H.	0337055	DO-13-A-NC	Lower Body Assembly for Closet. Component parts: Item 21 Lower Body, Coupling (CP), and Ground Joint Tail (CP)

# Dolphin® Flushometer

## PARTS LIST—DOLPHIN® FLUSHOMETER MODELS AND VARIATIONS

Item No.	Code No.	Part No.	Description
1.	<b>0337023</b>	DO-90-AAGNC	Closet Valve Body and Handle Assembly — Dolphin Type I
	<b>0337025</b>	DO-90-AAGNU	Urinal Valve Body and Handle Assembly — Dolphin Type II
2A.	<b>0388025</b>	H-710-A	Bak-Chek® Control Stop CP with ¾" NPTF Inlet for Adjustable Tail
	<b>0388022</b>	H-710-A	Bak-Chek® Control Stop CP with 1" NPTF Inlet for Adjustable Tail
2B.	<b>0388048</b>	NH-710-AG	Bak-Chek® Control Stop w/ ¾" NPTF Inlet for Ground Joint Tail (Naval Brass; use w/ Shipboard flushometer Models Type II Class A and B; requires A-35 Reducer Bushing)
	<b>0388058</b>	NH-710-AG	Bak-Chek® Control Stop w/ 1" NPTF Inlet for Ground Joint Tail (Naval Brass)
	<b>0388044</b>	NH-710-AGS	Bak-Chek® Control Stop w/ 1" NPSM Inlet for Ground Joint Tail (Naval Brass; use w/ Shipboard flushometer Models Type I and II when Sil-Brace Adapter is used)
3.	<b>0306196</b>	F-7	1" (25 mm) Supply Flange CP (Supplied When Valve is NOT Ordered w/ Sweat Solder Kit)
	<b>0306191</b>	F-7	¾" (19 mm) Supply Flange CP (Supplied When Valve is NOT Ordered w/ Sweat Solder Kit)
4.	<b>3308782</b>	H-633-AA	1" (25 mm) Sweat Solder Kit with Cast Set Screw Flange CP ("–YBYC" Variation)
	<b>3308788</b>	H-636-AA	¾" (19 mm) Sweat Solder Kit with Cast Set Screw Flange CP ("–YBYC" Variation)
5A.	<b>0323013</b>	V-500-AA	1-½" (38 mm) x 10-½" (267 mm) Vacuum Breaker Assembly CP (Model 110/111)
	<b>0323019</b>	V-500-AA	1-½" (38 mm) x 23" (534 mm) Vacuum Breaker Assembly CP (Model 115)
5B1.	<b>0396119</b>	F-101	1-½" (38 mm) x 10-1/2" (267 mm) Outlet Tube CP Type I Class B
5B2.	<b>0306093</b>	F-2-AT	Coupling CP w/ S-30 gasket
5C1.†	<b>0314004</b>	NF-1	1-½" (38 mm) Scored Outlet CP (Shipboard Model, Type I, Class A)
5C2.†	<b>2104180</b>	F-2-AT	Coupling CP w/ S-30 gasket
5D1.	<b>0323010</b>	V-500-A	1-½" (38 mm) Vacuum Breaker Assembly CP (Model 120 does not include F-2-A Coupling, see Item 5D2 below)
5D2.	<b>0306092</b>	F-2-A	Coupling CP w/ S-30 gasket
5E.†	<b>0306850</b>	NF-29-A	Outlet Tube Assembly ¾" (19 mm) x 6-½" (165 mm) Scored Outlet w/ ½" Offset (Shipboard Model, Type II, Class A)
5F.	<b>0306849</b>	NF-29-A	¾" (19 mm) x 6-½" (165 mm) Flush Connection with ½" Offset and ¾" x ½" Reducer for ½" Spud (Shipboard Model, Type II, Class B)
5G.†	<b>0323004</b>	V-500-AA	¾" (19 mm) x 10-½" (267 mm) Vacuum Breaker Assembly CP (Model 186)
5H.†	<b>0306780</b>	F-29-A	¾" (19 mm) x 10-½" (267 mm) Flush Connection CP (Model 186–XYW)
6.†	<b>0396302</b>	F-109	1-½" (38 mm) Flush Connection CP
7.	<b>SEE SLIP JOINT GASKETS AND RINGS TABLE ON BOTTOM, PAGE 30</b>		
7A.	<b>0306146</b>	F-5-AT	1-½" (38 mm) Spud Coupling Assembly (Models 110/111, 115, 120)
7B.	<b>0306125</b>	F-5-AW	¾" (19 mm) Spud Coupling Assembly (Model 186)
8.	<b>0306982</b>	F-40	½" (13 mm) Sil-Brace Adapter

† Cut to proper length at installation. Allow a minimum of 5" (127 mm) between tube ends when using rubber hose for shock mounted equipment.

† This Outlet Tube is available in various lengths. Consult factory for assistance.

**IMPORTANT NOTES**

With the exception of the control stop inlet, DO NOT USE pipe sealant or plumbing grease on any valve component or coupling!

Protect the chrome or special finish of Sloan flushometers — DO NOT USE toothed tools to install or service these valves.

Use a A-50 Super-Wrench™ or smooth jawed spud wrench to secure all couplings.

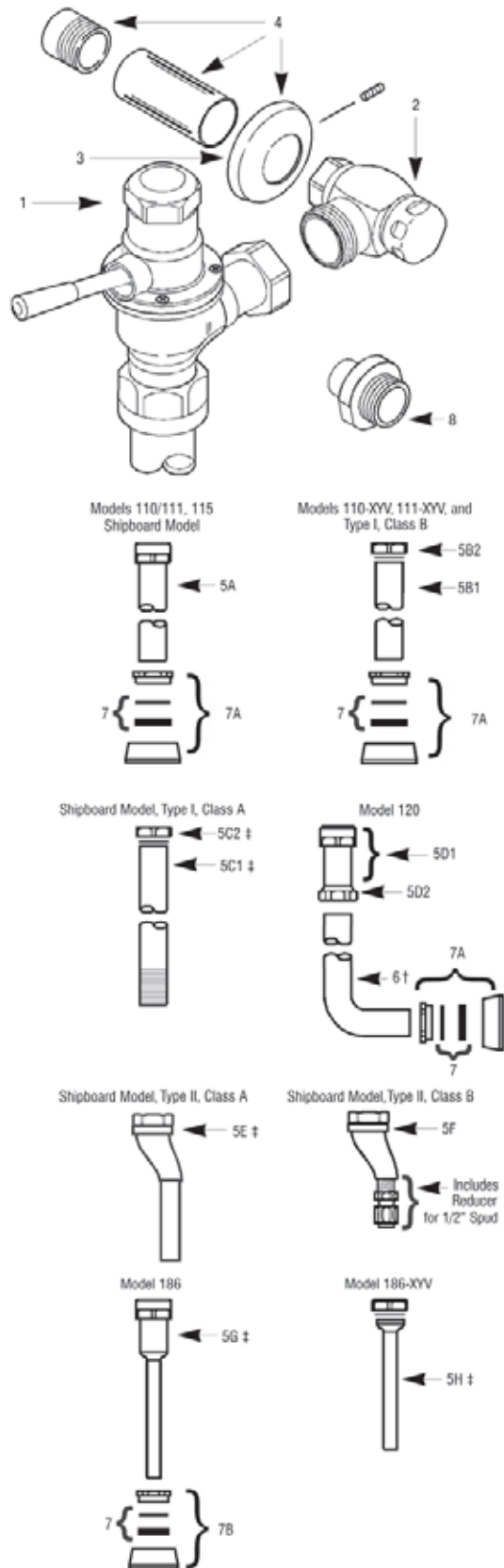

## Dolphin® Flushometer

### PARTS LIST—DOLPHIN® FLUSHOMETER MODELS AND VARIATIONS

Size	Code No.	Part No.	Description
<b>ITEM 7. Slip Joint Gaskets and Rings</b>			
1-1/2"	<b>5306058</b>	F-3	Red Friction Ring
	<b>5322001</b>	VBF-5	Black Slip Joint Gasket
	<b>0319086/5319086</b>	S-30	Flexible Seat
	<b>0319079</b>	S-21	Rigid Seat (rubber over brass)
1-1/2" x 1-1/4"	<b>0396062</b>	F-105	Slip Joint Gasket – Rigid
1-1/4"	<b>5306057</b>	F-3	Red Friction Ring
	<b>5322176</b>	VBF-5	Black Slip Joint Gasket
	<b>0307052/5307052</b>	G-21	Rigid Seat (rubber over brass)
1"	<b>5306056</b>	F-3	Red Friction Ring
	<b>5306115</b>	F-5	Black Slip Joint Gasket
3/4"	<b>5306055</b>	F-3	Red Friction Ring
	<b>5306113</b>	F-5	Black Slip Joint Gasket

### TROUBLESHOOTING GUIDE

#### 1. Flushometer DOES NOT function.

- A. Control stop or main valve is closed. Open control stop or main valve.
- B. Handle socket assembly is damaged. Replace DO-20 handle socket assembly.

#### 2. Volume of water is inadequate to siphon fixture.

- A. Control stop is not open enough. Adjust control stop for desired delivery of water volume.
- B. Timing of flushometer closure is set too fast. Remove DO-1 cover nut. Use a small blade screwdriver to turn DO-3 regulating screw clockwise.
- C. Water supply volume or pressure is inadequate. If no gauges are available to properly measure supply pressure or volume, completely open control stop and hold down flushometer handle without allowing it to close. If fixture siphons, increase timing of closure (see previous solution). If fixture does not siphon, steps must be taken to increase the supply pressure and/or volume. Contact fixture manufacturer for minimum water supply requirements of fixture.

#### 3. Flushometer closes immediately.

- A. Oil chamber of upper body is empty. Remove DO-1 cover nut. Fill oil chamber with SAE 10 Oil.
- B. Piston seal is worn or damaged. Replace DO-6 piston O-ring seal.

#### 4. Length of flush is too short (short flushing).

- A. Volume of oil in oil chamber of upper body is low. Remove DO-1 cover nut. Fill oil chamber with SAE 10 oil.
- B. Timing of flushometer closure is not adequately adjusted. Remove DO-1 cover nut. Using small blade screwdriver, turn DO-3 regulating screw clockwise until a satisfactory flush is achieved.

#### 5. Length of flush is too long (long flushing).

- A. Timing of flushometer closure not adequately adjusted. Remove DO-1 cover nut. Using small blade screwdriver, turn DO-3 regulating screw counterclockwise until a satisfactory flush is achieved.

#### 6. Oil is leaking from handle.

- A. Stem seals are worn or damaged. Replace two (2) SH-75 throttle seal O-rings.

#### 7. Valve DOES NOT close completely (water trickle).

- A. Compression spring is worn or damaged. Replace DO-16 compression spring.
- B. Flex-sac assembly is worn. Replace DO-15 flex-sac.

### CARE AND CLEANING INSTRUCTIONS

**DO NOT USE** abrasive or chemical cleaners to clean flushometers, they may dull the luster and attack the chrome finish. Use **ONLY** mild soap and water, and then wipe dry with a clean towel or cloth.

When cleaning, protect the exposed flushometer from any splattering of cleaner. Acids and cleaning fluids can discolor or remove chrome plating.

**When assistance is required, please contact Sloan Technical Support at: 1-888-SLOAN-14 (1-888-756-2614).**

# Slimline® Bedpan Washer Flushometer

Manual  
Flushometers



See Royal® flushometer on Page 7 for all parts kits and components

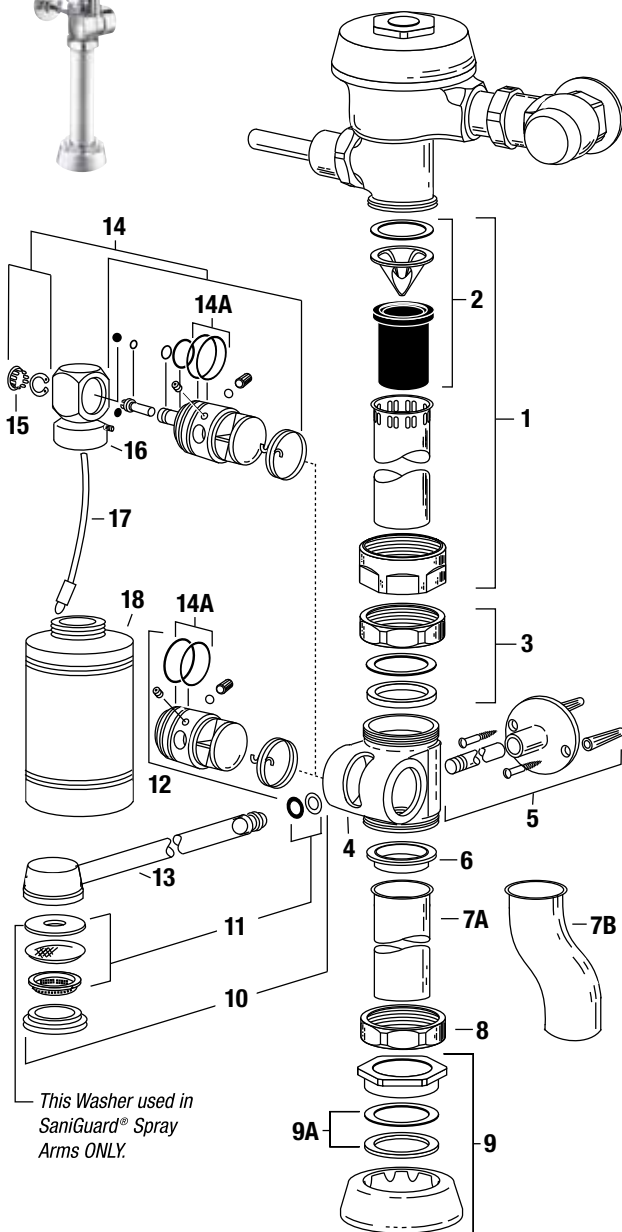

## PARTS LIST

Item No.	Code No.	Part No.	Description
1.	<b>0393009</b>	V-600-AA	1-1/2" x 21-1/2" CP Vacuum Breaker
	<b>0393008</b>	V-600-AA	1-1/2" x 13-1/2" CP Vacuum Breaker (ADA height)
	<b>0393029</b>	V-600-AA	1-1/2" x 21-1/2" CP Vacuum Breaker w/2" Offset
2.	<b>3323182</b>	V-651-A	Vacuum Breaker Repair Kit
3.	<b>0306093</b>	F-2-A	1-1/2" Slip Joint Coupling
4.	<b>0309001</b>	DV-1	Diverter Valve Body (non-Deoseptic bottle)
	<b>0309052</b>	DV-17	Diverter Valve Body (Deoseptic bottle)
5.	<b>3309035</b>	DV-1001-A	Wall Support Kit
6.	<b>0309027</b>	F-1003	Outlet Tube Gasket – for Flanged Tubes only
7A.	<b>0309029</b>	F-1005	Outlet Tube
7B.	<b>0396525</b>	F-182	Outlet Tube w/1-1/2" Offset
8.	<b>0306045</b>	F-2	1-1/2" Coupling Nut
9.	<b>0306146</b>	F-5-A	1-1/2" Spud Coupling Assembly
9A.	<b>SEE SLIP JOINT GASKETS AND RINGS TABLE ON BOTTOM, PAGE 30</b>		
10.	<b>3309044</b>	DV-32-AA	12" Spray Arm Replacement Kit
	<b>3309077</b>	DV-1014-A	Short Spray Arm Replacement Kit (for use with F-182 Offset Outlet Tube)
11.	<b>3309032</b>	DV-1007-A	Spray Arm Repair Kit
12.	<b>3309037</b>	DV-1003-A	Pivot Replacement Kit
—	<b>0309021</b>	DV-55-A	Diverter Valve Assembly and 12" Spray Arm Assembly includes: 3, 4, 8, 10, 12
—	<b>0309022</b>	DV-69-A	Diverter Valve Assembly and 10" Spray Arm Assembly includes: 3, 4, 8, 10, 12
13.	<b>3309015</b>	DV-1017-A	Repair Kit 15" Sanigard® Spray Arm

## DEOSEPTIC UNIT PARTS

Item No.	Code No.	Part No.	Description
14.	<b>3309036</b>	DV-1002-A	Deoseptic Pivot Replacement Kit
14A.	<b>5337075</b>	DO-6	O-ring-Piston – 2 required – 6 per package
14B.	<b>0309004</b>	DV-4	Set Screw
14C.	<b>0309016</b>	DV-16	Diverter Valve Seal Washer
14D.	<b>0309014</b>	DV-14	Diverter Valve Seal
15.	<b>0309024</b>	DV-21	Plug Button
16.	<b>0309033</b>	DV-33-A	Swivel & ball check Assembly
17.	<b>0309036</b>	DV-36-A	Aspirator Tube Assembly
18.	<b>0309018</b>	DV-29	Deoseptic Solution Bottle

## BEDPAN WASHER REBUILD KITS

Code No.	Part No.	Description
<b>5309031</b>	DV-50-A	Diverter Rebuild Kit Includes Outlet Tube Gasket (Item 6), Spray Arm Repair Kit (Item 11), and all items in Pivot Replacement Kit (Item 12) except Pivot.
<b>3309040</b>	DV-1004-A	Deoseptic Diverter Rebuild Kit Includes Outlet Tube Gasket (Item 6), Spray Arm Repair Kit (Item 11), and all items in Pivot Replacement Kit (Item 13) except Pivot.

To convert a standard diverter assembly to a deoseptic diverter assembly use:

<b>3309048</b>	DV-1005-A	Deoseptic Conversion Kit
----------------	-----------	--------------------------

## SANIGUARD® HANDLE ASSEMBLY

Code No.	Part No.	Description
<b>0302230</b>	B-73-A-SG	Handle Assembly CP (ADA complaint) with Sani-Guard

## Slimline® Bedpan Washer Flushometer

### ITEM 9A. SLIP JOINT GASKETS AND RINGS

Size	Code No.	Part No.	Description
1-1/2"	5306058	F-3	Red Friction Ring
	5322001	VBF-5	Black Slip Joint Gasket
	0319086/5319086	S-30	Flexible Seat
	0319079	S-21	Rigid Seat (rubber over brass)
1-1/2" x 1-1/4" Rigid	0396062	F-105	Slip Joint Gasket – Rigid
1-1/4"	5306057	F-3	Red Friction Ring
	5322176	VBF-5	Black Slip Joint Gasket
	0307052/5307052	G-21	Rigid Seat (rubber over brass)
1"	5306056	F-3	Red Friction Ring
	5306115	F-5	Black Slip Joint Gasket
3/4"	5306055	F-3	Red Friction Ring
	5306113	F-5	Black Slip Joint Gasket

### SLIMLINE® BEDPAN WASHER RETROFIT DIVERTERS

Code No.	Part No.	Description
3309022	DV-100	CP Diverter Valve Assembly
3309047	DV-105	CP Deoseptic Diverter Assembly
3309052	DV-135	CP Deoseptic Diverter Assembly 2" Offset
3309061	DV-115	CP Deoseptic Diverter Assembly ADA
3309062	DV-115-R	CP Deoseptic Diverter Assembly ADA
3309065	DV-120	CP Diverter Assembly ADA 1-1/2" Offset
3309066	DV-120-R	CP Diverter Assembly ADA 1-1/2" Offset
3309069	DV-125	CP Deoseptic Diverter Assembly ADA Offset
3309070	DV-125-R	CP Deoseptic Diverter Assembly ADA Offset
3309051	DV-130	CP Diverter Assembly 2 Offset

### SLIMLINE® BEDPAN REPAIR KITS

3309035	DV-1001	Kit Bedpan Washer Wall Support
3309036	DV-1002	Repair Kit Deoseptic Pivot
3309037	DV-1003	Repair Kit Bedpan Washer Pivot
3309040	DV-1004	Repair Kit Deoseptic Diverter
3309048	DV-1005	Conversion Kit Deoseptic Diverter Assembly
3309032	DV-1007	Repair Kit Spray Arm
3309077	DV-1014	Repair Kit 10" Spray Arm
3309044	DV-32-AA	Repair Kit 12" Spray Arm
3309015	DV-1017-A	Repair Kit 15" Spray Arm

### REBUILDING THE SLOAN SLIMLINE DIVERTER ASSEMBLY:

**To disassemble diverter valve:** Loosen set screw and remove spray arm from pivot. Slide pivot out of diverter valve body.

#### To further disassemble deoseptic diverters:

Remove plug cap and retaining ring. Slide swivel and ball check assembly off pivot shaft, exposing all internal components.

*NOTE: This disassembly can be done without removing pivot assembly from diverter valve body.*

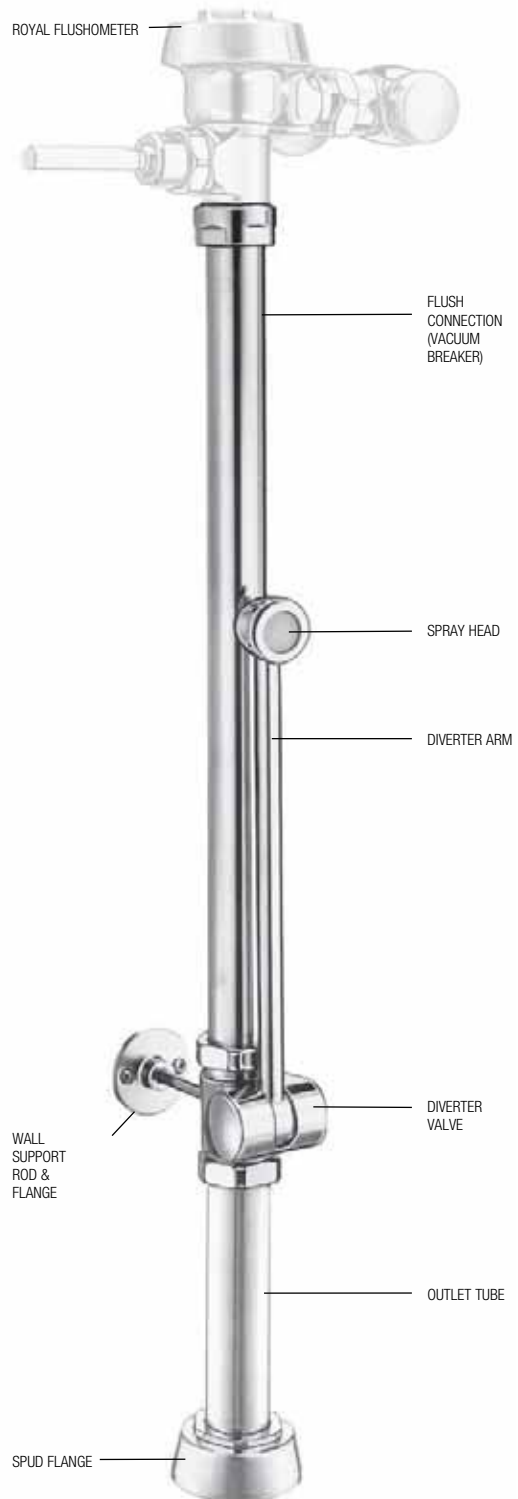
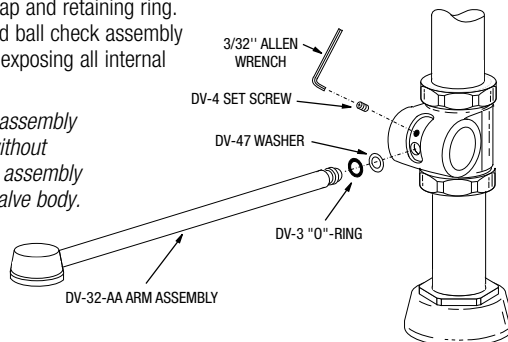

Manual Flushometers

## Slimline® Bedpan Washer Flushometer

### TROUBLESHOOTING GUIDE

See Royal® flushometer troubleshooting section for all problems regarding the flushometer and the flushing discharge.

#### 1. Diverter leaking at spray arm.

A. Diverter spray arm (old style) is damaged. Replace diverter arm with new spray arm replacement kit. *NOTE: On old style diverter spray arm, the spray arm O-ring was placed on groove at the end of the spray arm. When installing new spray arm kit, place washer into bottom of hole of nozzle pivot. Then place the O-ring on top of washer. Insert new spray arm into the pivot, pressing in slightly. While holding spray arm in place, tighten set screw.*

B. Spray arm O-ring is damaged or installed improperly. Re-install o-ring as described above in step (A.). If leakage persists replace using spray arm kit DV-1007-A.

#### 2. Diverter leaking at nozzle pivot.

A. One or both pivot O-rings are worn. Replace nozzle pivot assembly. Use pivot replacement kit.

B. Diverter seal washer worn or missing. Replace pivot seals. Use diverter rebuild kit.

C. Nozzle pivot damaged or defective. Replace nozzle pivot assembly. Use pivot replacement kit.

#### 3. Erratic spray pattern from spray arm nozzle.

A. Debris clogging nozzle screen. Wash nozzle screen under running water.

B. Damaged or missing nozzle screen or spray disc. Replace using DV-1007-A spray arm replacement kit.

#### 4. Deoseptic solution not siphoning from bottle during flush cycle (deoseptic models only).

A. Adjusting screw not open. Open adjusting screw until adequate amount of solution is siphoned from bottle during flush cycle.

B. Aspirator tube screen clogged. Remove solution bottle. Remove aspirator tube from swivel & ball check assembly and wash screen under running water.

C. Aspirator tube not installed completely onto swivel & ball check assembly. Remove solution bottle. Make sure aspirator tube is pushed completely onto nipple of swivel & ball check assembly.

D. Aspirator tube cracked. Replace aspirator tube assembly.

E. Rubber ball check stuck inside swivel & ball check assembly. Remove solution bottle and aspirator tube from swivel & ball check assembly. Gently insert small implement (paper clip, small dia. hex key, etc.) into nipple of swivel & ball check assembly to dislodge rubber ball check. Stop pushing once water starts to trickle from nipple. *NOTE: If ball is pushed too hard or too far it may fall out of seat. Should this occur, the swivel & ball check assembly must be removed and ball replaced. To do this, remove retaining ring using retaining clip pliers. Pull swivel & ball check assembly off of adjusting screw being careful not to drop rubber ball check. Place rubber ball back into seat of swivel & ball check assembly and reassemble. If ball and seals appear worn rebuild.*

#### 5. Water leaking back into solution bottle.

A. Rubber ball damaged or missing. Replace rubber ball using DV-1004-A deoseptic diverter rebuild kit.

B. Rubber ball not sitting in seat of swivel & ball check assembly. Remove swivel & ball check assembly taking care not to lose rubber ball. Insert rubber ball back into seat of swivel & ball check assembly and reassemble. *NOTE: Follow steps in solution (E.) of problem 4.*

### CARE AND CLEANING INSTRUCTIONS

**DO NOT USE** abrasive or chemical cleaners to clean flushometers as they may dull the luster and attack the chrome or special decorative finishes. Use **ONLY** mild soap and water, then wipe dry with clean cloth or towel.

While cleaning the bathroom tile, the flushometer should be protected from any splattering of cleaner. Acids and cleaning fluids can discolor or remove chrome plating.

**When assistance is required, please contact  
Sloan Technical Support at: 1-888-SLOAN-14 (1-888-756-2614).**