

INSTALLATION INSTRUCTIONS FOR STAINLESS STEEL WATER CLOSETS, URINALS AND COMBINATION FIXTURES



**Concealed Flushometer
with Standard
Push Button Actuator**

**Closet Flushometer
1½" (38 mm) Back Inlet**
MODELS 601, 603, 611 & 681

**Urinal Flushometer
1½" (38 mm) & ¾" (19 mm)
Back Inlet**
MODELS 609 & 613



**Concealed Flushometer
with Hydraulic
Push Button Actuator**

**Closet Flushometer
1½" (38 mm) Back Inlet**
MODEL 9603

**Urinal Flushometer
1½" (38 mm) & ¾" (19 mm)
Back Inlet**
MODELS 9609 & 9613

Made in the U.S.A.

LIMITED WARRANTY

Unless otherwise noted, Sloan Valve Company warrants this product, manufactured and sold for commercial or industrial uses, to be free from defects in material and workmanship for a period of three (3) years (one (1) year for special finishes, SF faucets, PWT electronics and 30 days for PWT software) from date of first purchase. During this period, Sloan Valve Company will, at its option, repair, replace, or refund the purchase price of any product which fails to conform with this warranty under normal use and service. This shall be the sole and exclusive remedy under this warranty. Products must be returned to Sloan Valve Company, at customer's cost. No claims will be allowed for labor, transportation or other costs. This warranty extends only to persons or organizations who purchase Sloan Valve Company's products directly from Sloan Valve Company for purpose of resale. This warranty does not cover the life of the batteries.

THERE ARE NO WARRANTIES WHICH EXTEND BEYOND THE DESCRIPTION ON THE FACE HEREOF. IN NO EVENT IS SLOAN VALVE COMPANY RESPONSIBLE FOR ANY CONSEQUENTIAL DAMAGES OF ANY MEASURE WHATSOEVER.

PRIOR TO INSTALLATION

Check that the "L" dimension shown on the flushometer package is correct for your application. Determine the "L" dimension for your application by using the following formula:

"L" dimension = Wall Thickness (to the nearest whole inch) + 2-3/4" (Models 609, 611 and 613), 4-3/4" (Models 601 and 603) OR 6-3/4" (Model 681).

Prior to installing the Sloan Prison Flushometer, perform the following functions using the rough-in diagrams on Pages 2 and 3.

- Bore a 1-1/2" (38 mm) opening in wall for standard or hydraulic push button actuator
- Bore a 1-2" (25-51 mm) opening in wall for piping. Refer to the Rough-in drawings on Pages 2 and 3. (This is **NOT** required if wall sleeve is used in conjunction with fixture.)
- Install stainless steel prison fixture
- Install drain line
- Install water supply line

IMPORTANT:

- **INSTALL ALL PLUMBING IN ACCORDANCE WITH APPLICABLE CODES AND REGULATIONS.**
- **WATER SUPPLY LINES MUST BE SIZED TO PROVIDE AN ADEQUATE VOLUME OF WATER FOR EACH FIXTURE.**
- **FLUSH ALL WATER LINES PRIOR TO MAKING CONNECTIONS.**

Sloan's flushometers are designed to operate with 10 to 100 psi (69 to 689 kPa) of water pressure. **THE MINIMUM PRESSURE REQUIRED BY THE VALVE IS DETERMINED BY THE TYPE OF FIXTURE SELECTED.**

Consult fixture manufacturer for minimum pressure requirements. Most Low Consumption water closets (1.6 gpf/6.0 Lpf) require a minimum flowing pressure of 25 psi (172 kPa).

TOOLS REQUIRED FOR INSTALLATION

- Standard set of hex wrenches
- Parker Tube Cutter (PTC)
- Sloan A-50 Super-Wrench™, Sloan A-109 Plier Wrench or smooth jawed spud wrench

ROUGH-INS

MODELS 601 & 603

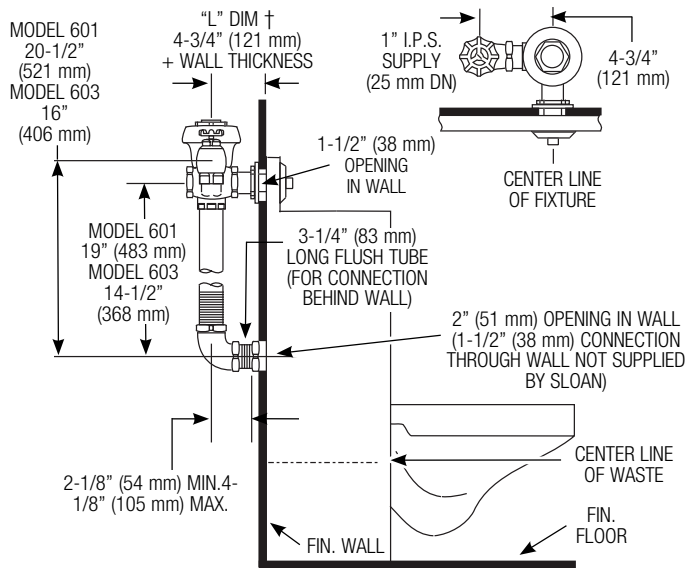

MODEL 611

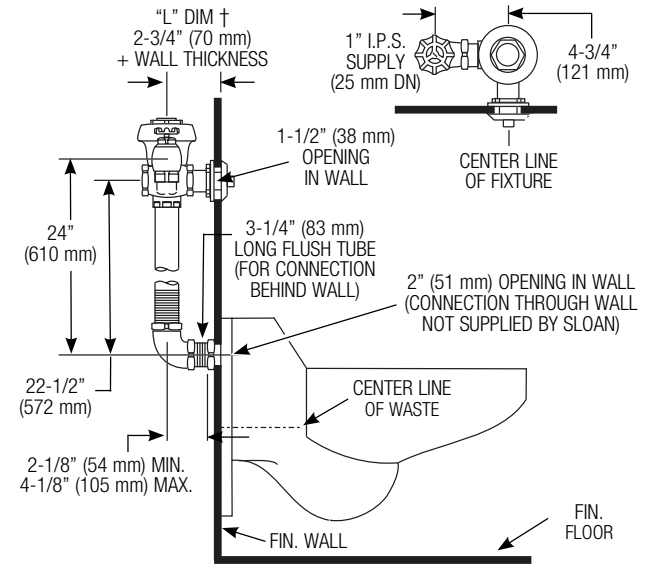

MODEL 609

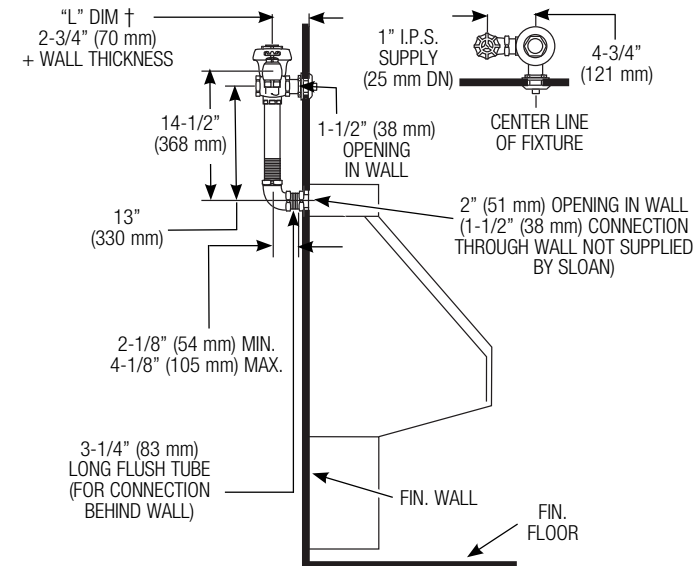

MODEL 613

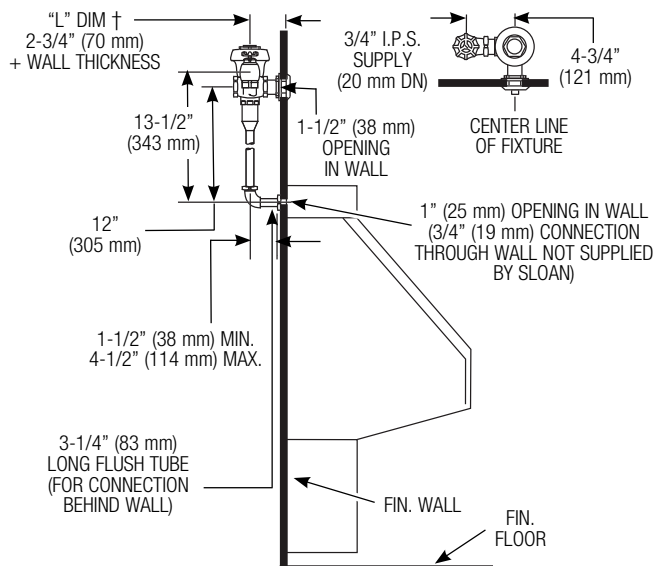

MODEL 681

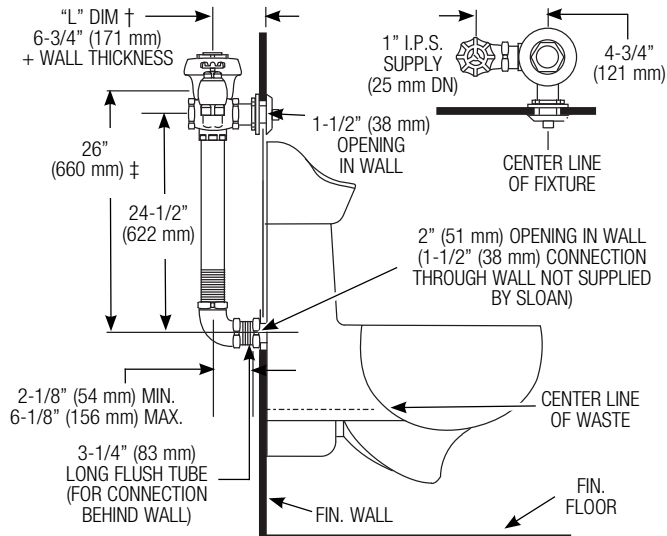

AFD VARIATION

If the valve installation includes an Anti-Flood Device installed between the valve body and the vacuum breaker, the valve must be ordered with the "AFD" variation. This assures that the proper length Vacuum Breaker tube is supplied. Anti-Flood Device is supplied by the fixture manufacturer. Consult the fixture manufacturer for installation requirements.

† Check that the "L" dimension shown on the flushometer package is correct for your application. Determine the "L" dimension for your application by using the following formula:

For Models 609, 611 and 613 – "L" Dim. = wall thickness (measured to nearest whole inch) + 2-3/4" (70 mm)

For Models 601 and 603 – "L" Dim. = wall thickness (measured to nearest whole inch) + 4-3/4" (121 mm)

For Model 681 – "L" Dim. = wall thickness (measured to nearest whole inch) + 6-3/4" (171 mm)

‡ For Solenoid Activated Flushometers (ES and ESM variations), the Water Supply Rough-in dimension is 16" (406 mm).

ROUGH-INS (CONTINUED)

MODEL 9603 – WATER CLOSET

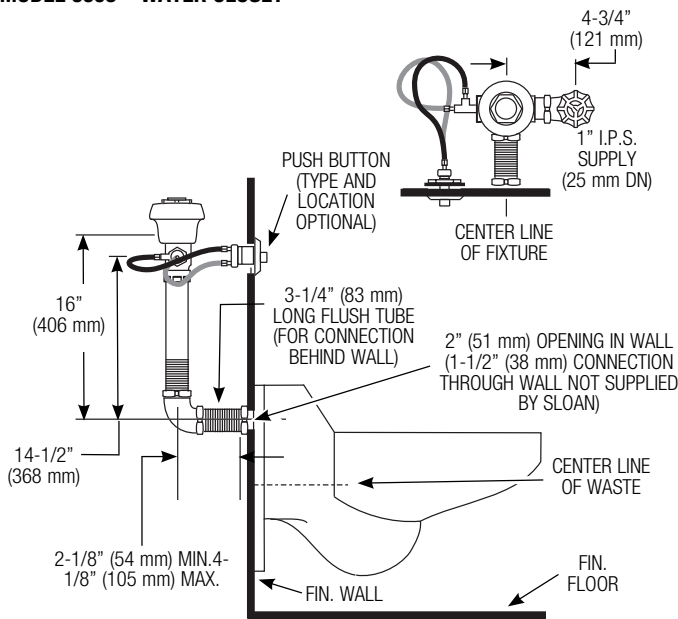

MODEL 9603 – COMBINATION FIXTURE

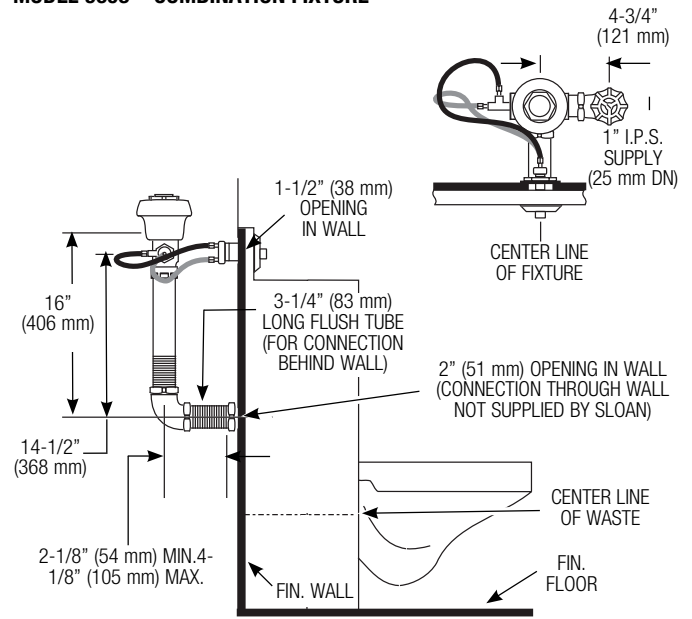

MODEL 9609 - URINAL

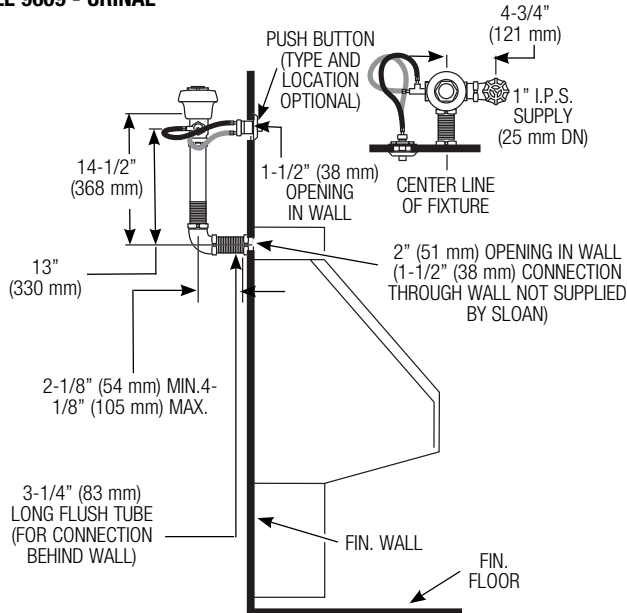

MODEL 9613 – COMBINATION FIXTURE

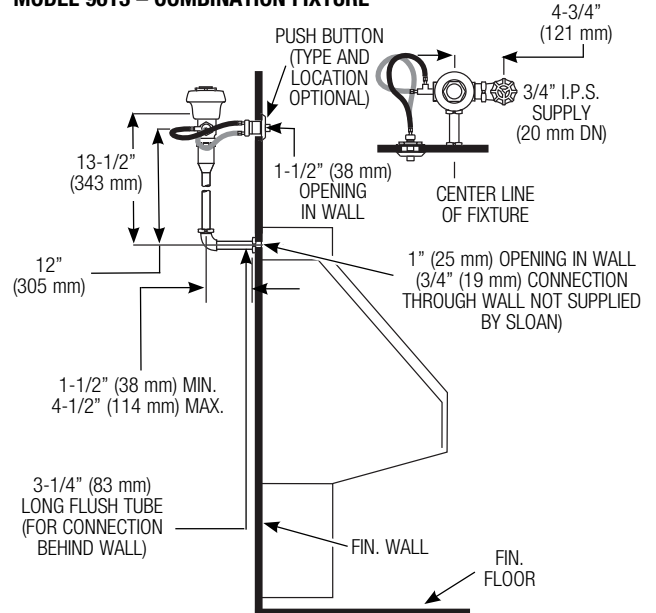

!!! IMPORTANT !!!

NEVER OPEN THE CONTROL STOP TO WHERE THE FLOW FROM THE VALVE EXCEEDS THE FLOW CAPABILITY OF THE FIXTURE. IN THE EVENT OF A VALVE FAILURE, THE FIXTURE MUST BE ABLE TO ACCOMMODATE A CONTINUOUS FLOW FROM THE VALVE.

!!! IMPORTANT !!!

WITH THE EXCEPTION OF CONTROL STOP INLET, DO NOT USE PIPE SEALANT OR PLUMBING GREASE ON ANY VALVE COMPONENT OR COUPLING!

!!! IMPORTANT !!!

DUE TO THE HIGH BACK PRESSURES THAT CAN BE CREATED BY STAINLESS WATER CLOSETS AND COMBINATION FIXTURES, THE FOLLOWING PROCEDURES MUST BE FOLLOWED WHEN INSTALLING THE FLUSH CONNECTIONS. FAILURE TO FOLLOW THESE PROCEDURES CAN RESULT IN SEPARATIONS.

!!! IMPORTANT !!!

ONLY USE PIPE THREAD SEALANT WHEN INDICATED IN THIS MANUAL. ONLY USE THE PIPE THREAD SEALANT SUPPLIED BY SLOAN.

!!! IMPORTANT !!!

THIS PRODUCT CONTAINS MECHANICAL AND/OR ELECTRICAL COMPONENTS THAT ARE SUBJECT TO NORMAL WEAR. THESE COMPONENTS SHOULD BE CHECKED ON A REGULAR BASIS AND REPLACED AS NEEDED TO MAINTAIN THE VALVE'S PERFORMANCE.

!!! IMPORTANT !!!

PROTECT THE CHROME OR SPECIAL FINISH OF SLOAN FLUSHOMETERS. DO NOT USE TOOTHED TOOLS TO INSTALL OR SERVICE VALVES. USE A SLOAN A-50 SUPER WRENCH™ OR SMOOTH JAWED SPUD WRENCH TO SECURE COUPLINGS. SEE "CARE AND CLEANING" SECTION OF THIS MANUAL.

1 - INSTALL OPTIONAL SWEAT SOLDER ADAPTER (ONLY IF SUPPLY PIPE DOES NOT HAVE MALE THREAD) AND INSTALL CONTROL STOP

A For Sweat Solder applications, slide Threaded Adapter onto water supply pipe until end of pipe rests against shoulder of Adapter.

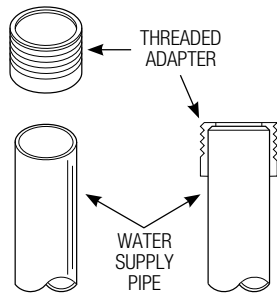

B Sweat solder the Adapter to pipe.

C Install the Sloan Bak-Chek® Control Stop to the water supply line with the outlet positioned as required. Note: For standard and hydraulic push button applications, concealed valves can be installed with the Control Stop on either the left or right side of the valve.

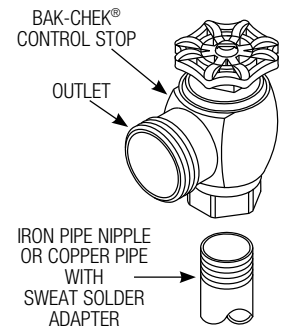

D Install Push Button Actuator by following Step 2A, 2B or 2C depending on your application.

2A - INSTALL PUSH BUTTON ACTUATOR – STANDARD PUSH BUTTON APPLICATION ONLY

TO MOUNT ACTUATOR FROM BEHIND THE WALL:

A Remove the Flange and insert Actuator Shaft and Bushing Assembly from the back of the wall through the Combination Fixture or 1-1/2" (38 mm) wall opening.

B Apply several drops of thread sealant to threads of Actuator Shaft at location shown.

C Reinstall and tighten the Flange. Tighten the Mounting Nut against the back of the wall.

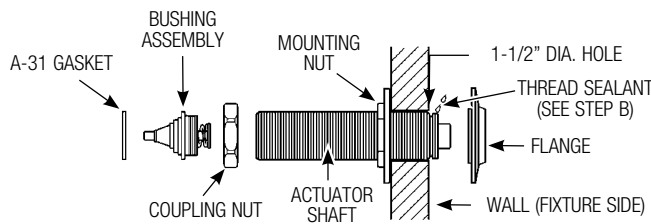

TO MOUNT ACTUATOR FROM FIXTURE SIDE:

A Remove the bushing assembly, coupling nut and mounting nut from the actuator shaft. Insert the actuator Shaft through the opening in front of the wall.

B Remove flange from actuator shaft. Apply several drops of thread sealant to threads of actuator shaft at location shown. Reinstall and tighten the flange.

C Reinstall Mounting Nut onto the actuator shaft. Tighten securely until it is against the back of the wall. Reinstall the coupling nut, bushing assembly and A-31 Gasket.

2B - INSTALL PUSH BUTTON ACTUATOR – HYDRAULIC PUSH BUTTON APPLICATION ONLY

MBFW (METAL BUTTON - FIXTURE WALL) VARIATION HY-100-A METAL PUSH BUTTON ACTUATOR

Note: Behind wall access required to install HY-100-A Metal Push Button Actuator.

A If not already completed, bore a 1-1/2" (38 mm) diameter hole in wall for the push button actuator. Refer to the Rough-in drawings on Pages 2 and 3.

B Screw threaded rod into back of push button actuator.

C Thread actuator assembly nut onto threaded end of push button actuator.

D Slide spring over metal push button until it snaps into place. Insert metal push button into button flange.

E Place spacer ring over threads of button flange and thread button flange assembly into actuator assembly nut.

F From behind wall, run plastic tubing through optional spacer sleeve (notched end of sleeve toward rear) and wall. Spacer sleeve only required if wall thickness is LESS than 2" (51 mm).

G Attach plastic tubing. See: steps to attach plastic tubing on page 5.

H Insert push button actuator assembly into the 1-1/2" wall hole.

I From behind wall, slide spacer sleeve (if required) over threaded rod and rest it against rear of wall. Slide retaining bar onto threaded rod and into slots of sleeve (if required), or against wall if sleeve is not required. Install lockwasher and nut onto threaded rod. Tighten securely. Carefully cut excess threaded rod, making certain to not damage plastic tubing.

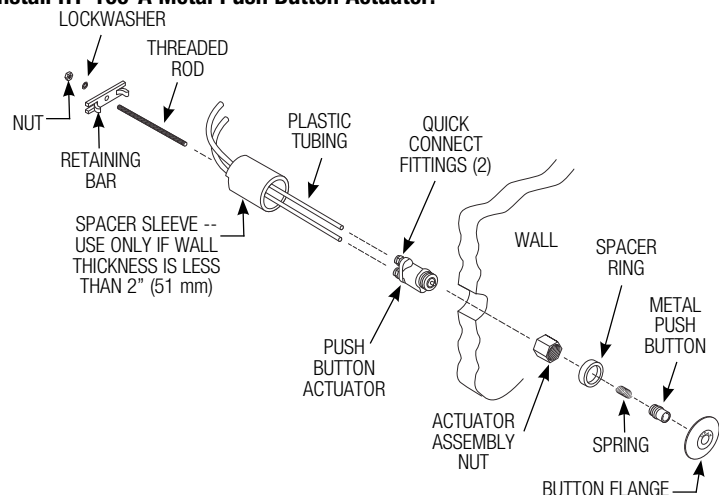

2B - INSTALL PUSH BUTTON ACTUATOR – HYDRAULIC PUSH BUTTON APPLICATION ONLY

MBPM (METAL BUTTON - PANEL MOUNT) VARIATION HY-108-A METAL PUSH BUTTON ACTUATOR

Note: Use HY-108-A metal push button actuator on punched stainless steel plates and security fixtures with front access.

- A** Attach Plastic Tubing to Push Button Actuator. See: Steps to Attach Plastic Tubing below.
- B** Thread actuator assembly nut onto threaded end of push button actuator.
- C** Slide spring over metal push button until it snaps into place. Insert metal push button into button flange.
- D** From front of panel, insert button flange assembly into hole of panel. Behind panel, place washer over threads of button flange. Thread button flange onto actuator. Tighten flange securely.

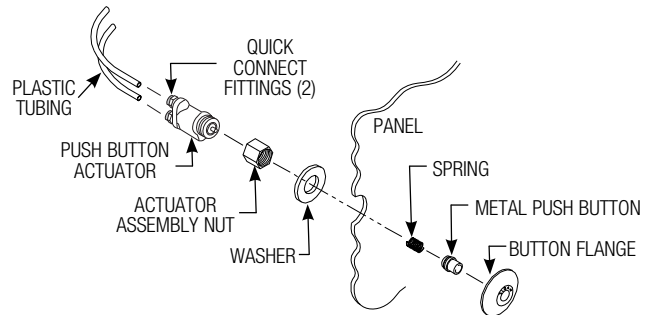

STEPS TO ATTACH PLASTIC TUBING

- A** The push button valve actuator is connected to the flushometer body by two plastic tubes, marked "L" and "O". Match markings on the tubes to markings on the actuator.
- B** Cut off excess plastic tubing with plastic tube cutter (PTC) so that there will be about 3" to 4" (76-102 mm) of slack when push button actuator is installed. If the "L" and "O" markings on the tube will be cut off, remark the tubing appropriately to not lose identification.

- C** Slide plastic tubing into its corresponding valve actuator fitting. Pull tubing to make sure connection is secure. (Tubing can be removed by pressing on blue connection button to release.)

!!! IMPORTANT !!!
MUST USE SLOAN APPROVED TUBING ONLY

3 - INSTALL VACUUM BREAKER AND FLUSH CONNECTION

!!! IMPORTANT !!!

DUE TO THE HIGH BACK PRESSURES THAT CAN BE CREATED BY STAINLESS WATER CLOSETS AND COMBINATION FIXTURES, THE FOLLOWING PROCEDURES MUST BE FOLLOWED WHEN INSTALLING THE FLUSH CONNECTION. FAILURE TO FOLLOW THESE PROCEDURES CAN RESULT IN SEPARATIONS. FOR SECURE CONNECTIONS IN HIGHER PRESSURE AND OTHER SEVERE CONDITION APPLICATIONS, THE FLUSH CONNECTIONS CAN BE SWEAT SOLDERED. REMOVE ALL PLASTIC AND RUBBER GASKETS BEFORE BEGINNING SOLDERING PROCESS.

NOTE

Sloan Prison Flushometers are designed to connect to a stainless steel prison fixture in the chase behind the wall. A 1-1/2" (38 mm) pipe connection (NOT supplied by Sloan) must be used to connect the fixture inlet from the wall to the flush connection. For urinals using a Model 613 or 9613 valve, a 3/4" (19 mm) pipe connection must be used to connect the fixture inlet from the wall to the flush connection.

- A** Secure flanged end of F-100 flush connection to the 1-1/2" (38 mm) pipe using a 1-1/2" F-2-A coupling nut with S-21 gasket. Tighten securely.

For urinals using a Model 613 or 9613 Valve, secure flanged end of F-15-A flush connection to the 3/4" (19 mm) pipe using a 3/4" F-2-AW slip joint coupling (rubber gasket, nylon slip gasket and coupling nut). Tighten securely.

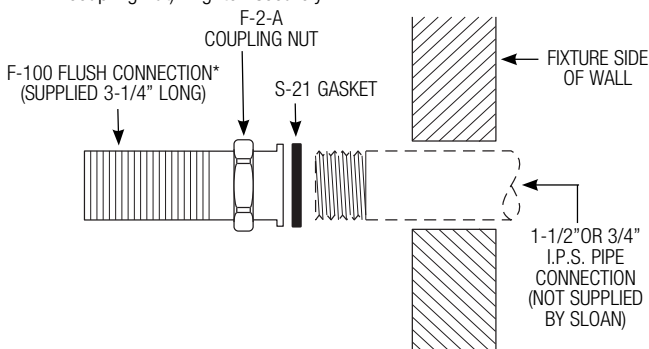

- B** Cut Vacuum Breaker and Flush Connection tubes to length.

!!! IMPORTANT !!!
WHEN CUTTING SCORED TUBES TO FIT, ALWAYS KEEP AT LEAST 1-1/4" (32 mm) OF SCORING TO ASSURE PROPER ENGAGEMENT WITH COMPRESSION COUPLING.

- C** Slide the coupling nut, nylon slip gasket and rubber gasket onto the vacuum breaker and flush connection tubes.

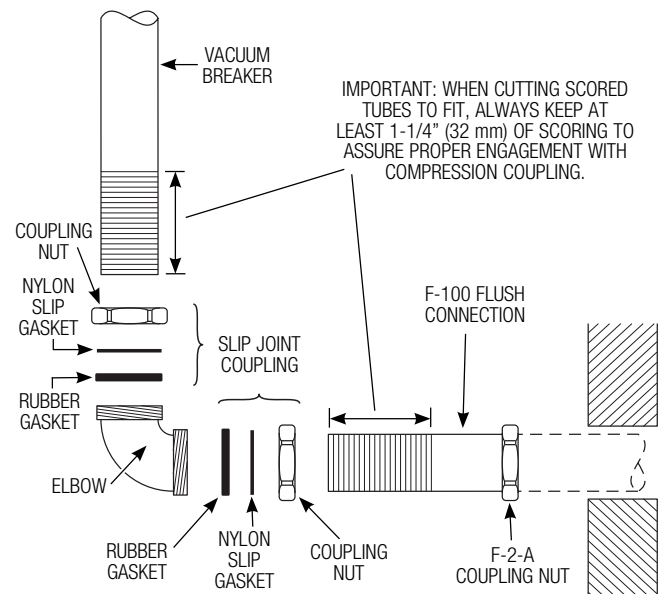

4 - INSTALL FLUSHOMETER

- A** Insert adjustable tailpiece into control stop. (For standard push button, also mount flushometer to actuator assembly.) Lubricate tailpiece o-ring with water. Hand tighten tailpiece coupling. (For standard push button, also hand tighten actuator assembly coupling.)
- B** Align flushometer directly above the vacuum breaker flush connection by sliding the flushometer Body IN or OUT as needed. Tighten vacuum breaker coupling by hand.
- C STANDARD PUSH BUTTON ONLY:**
Align flushometer body. Using a wrench, securely tighten couplings in the order given: **(1)** tailpiece coupling, **(2)** actuator coupling, **(3)** vacuum breaker coupling, **(4)** slip joint couplings, and **(5)** spud coupling.

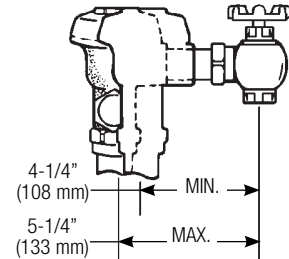
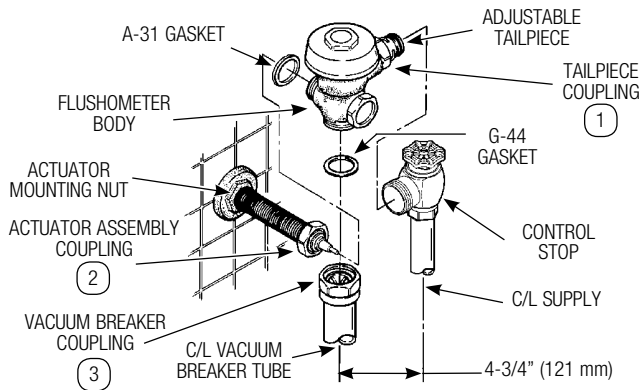

Maximum adjustment of Sloan Adjustable Tailpiece is 1/2" (13 mm) IN or OUT from the standard 4-3/4" (121 mm) (flushometer centerline to Control Stop centerline). If roughing-in measurement exceeds 5-1/4" (133 mm), consult factory for longer tailpiece.

- D HYDRAULIC PUSH BUTTON ONLY:**
Align flushometer body. Using a wrench, securely tighten couplings in the order given: **(1)** tailpiece coupling, **(2)** vacuum breaker coupling, **(3)** slip joint couplings, and **(4)** pipe coupling.

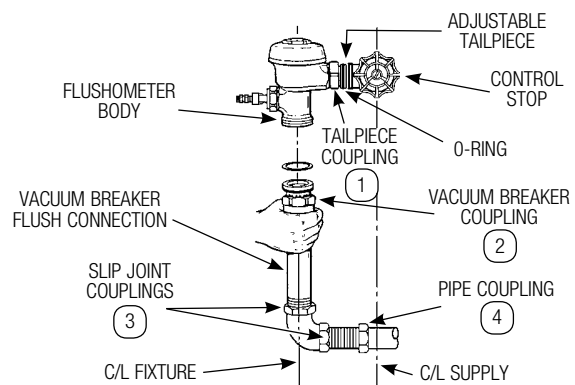

5 - INSTALL TUBING TO VALVE ACTUATOR (HYDRAULIC PUSH BUTTON APPLICATIONS ONLY)

NOTE

OBSERVE "L" AND "O" MARKINGS ON TUBING. TUBING MUST BE CONNECTED TO CORRESPONDING "L" AND "O" MARKINGS ON PUSH BUTTON ACTUATOR.

- A** Cut off excess plastic tubing with plastic tube cutter (PTC) so that there will be about 3" to 4" (76-102 mm) of slack when push button actuator is installed. If the "L" and "O" markings on the tube will be cut off, remark the tubing appropriately to not lose identification.
- B** Slide plastic tubing into its corresponding valve actuator fitting. Pull tubing to make sure connection is secure. (Tubing can be removed by pressing on blue connection button to release.)

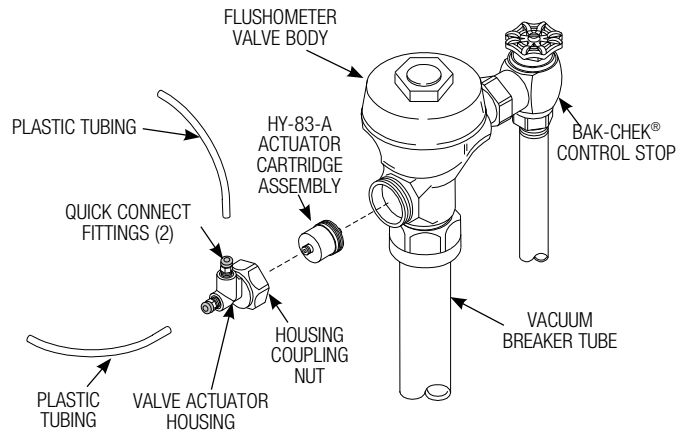

6 - FLUSH OUT SUPPLY LINE AND ADJUST CONTROL STOP

- A** Shut off control stop by turning handle CLOCKWISE. Then remove flushometer cover.
- B** Lift out the inside parts assembly as a complete unit. Reinstall flushometer cover and tighten with wrench. Open control stop. Turn on water supply to flush line of any debris or sediment.
- C** Shut off control stop and remove flushometer cover. Reinstall inside parts assembly and flushometer cover. Tighten cover with wrench. Open control stop and activate flushometer valve.

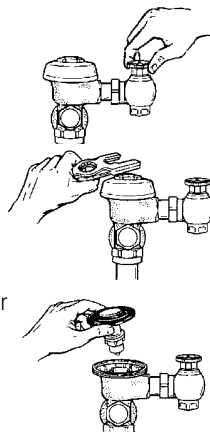

- D** Adjust control stop to meet flow rate required for proper cleansing of fixture. Open control stop COUNTERCLOCKWISE ONE FULL turn from closed position. Activate flushometer. Adjust control stop after each flush until the rate of flow delivered properly cleanses the fixture.

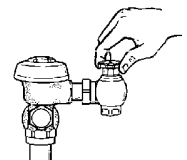

!!! IMPORTANT !!!

SLOAN PRISON MODEL FLUSHOMETERS ARE ENGINEERED FOR QUIET OPERATION. EXCESSIVE WATER FLOW CREATES NOISE, WHILE TOO LITTLE WATER FLOW MAY NOT SATISFY THE NEEDS OF THE FIXTURE. PROPER ADJUSTMENT IS MADE WHEN THE PLUMBING FIXTURE IS CLEANSED AFTER EACH FLUSH WITHOUT SPLASHING WATER OUT FROM THE LIP AND A QUIET FLUSHING CYCLE IS ACHIEVED.

NEVER OPEN CONTROL STOP TO WHERE THE FLOW FROM THE VALVE EXCEEDS THE FLOW CAPABILITY OF THE FIXTURE. IN THE EVENT OF A VALVE FAILURE, THE FIXTURE MUST BE ABLE TO ACCOMMODATE A CONTINUOUS FLOW FROM THE VALVE.

TROUBLESHOOTING GUIDE

PUSH BUTTON ACTUATOR ASSEMBLY (HYDRAULIC PUSH BUTTON APPLICATIONS ONLY)

1. PUSH BUTTON LEAKS.

The actuator cartridge has an accumulation of lime or its seals are damaged or worn. Replace the cartridge (HY-32-A).

2. THE FLUSHOMETER DOES NOT FLUSH AND LEAKAGE IS VISIBLE BELOW THE VALVE.

- Actuator cartridge is clogged by foreign material. Remove the cartridge, inspect and clean under running water.
- The actuator cartridge has an accumulation of lime or its seals are damaged or worn. Replace the cartridge (HY-32-A).
- Plastic Tubing is not installed correctly. Reinstall Plastic Tubing (see Steps 2 & 5).

ACTUATOR CARTRIDGE REMOVAL:

- Remove the button or actuator assembly from the wall or fixture.
- Disassemble the flange or button assembly from the actuator body.
- Unscrew the cartridge from the actuator body.

NOTE: The metal Push Button was designed to be vandal-proof and must be removed from the wall or fixture for service.

FLUSHOMETER ACTUATOR ASSEMBLY (HYDRAULIC PUSH BUTTON APPLICATIONS ONLY)

1. THE FLUSHOMETER DOES NOT FLUSH OR FLUSHES ONCE BUT DOES NOT REACTIVATE WHEN THE BUTTON IS PUSHED.

- The plunger is lodged in the actuator cartridge or the plunger by-pass hole is clogged. Remove the actuator housing and cartridge and clean under running water. If problem persists after cleaning, replace the cartridge (HY-83-A).
- Plastic tubing is not installed correctly. Reinstall plastic tubing (see Steps 2 & 5).

REMOVAL OF THE ACTUATOR FROM THE FLUSHOMETER:

- Turn off water at the control stop.
- Unscrew the housing coupling nut from the flushometer.
- Remove the actuator housing from the flushometer. The tubing connections can be left intact.
- Carefully remove the actuator cartridge from the flushometer body to prevent the actuator from abrupt separation due to expansion of an internal spring. If the actuator cartridge is lodged in the body cavity, grip the exposed portion of the cartridge gently with channel-lock pliers and rotate back and forth to loosen the o-ring seal.
- Separate the actuator housing to reveal the spring and plunger.

PUSH BUTTON ACTUATOR ASSEMBLY (STANDARD PUSH BUTTON APPLICATIONS ONLY)

1. FLUSHOMETER DOES NOT FUNCTION.

Push button assembly is worn; replace Push Button.

2. PUSH BUTTON ASSEMBLY LEAKS.

The B-39 seal is worn or deteriorated. Install new B-39 seal.

NOTE: LUBRICATE THE SEAL W/ WATER TO EASE INSTALLATION ONTO THE B-40 BUSHING.

FLUSHOMETER SERVICE (STANDARD AND HYDRAULIC PUSH BUTTON APPLICATIONS)

1. FLUSHOMETER DOES NOT FUNCTION.

- Control stop or main valve is closed. Open control stop or main valve.
- Relief Valve is worn.
ROYAL: Replace with relief valve from Royal Performance Kit.
REGAL: Replace with relief valve from Inside Parts Kit.
- Water pressure is too high. Reduce water pressure.

2. VOLUME OF WATER IS INADEQUATE AND WILL NOT SIPHON FIXTURE.

- Control stop is not open wide enough. Adjust control stop to deliver desired volume of water.
- Flushometer contains urinal parts. Replace urinal parts with closet parts.
- Low consumption flushometer is installed on a fixture that is not a low consumption fixture.
ROYAL: Replace dual filtered fixed bypass diaphragm assembly with appropriate Royal Performance Kit.
REGAL: Replace A-41-A Inside Parts Kit with A-38-A water saver kit.
- Water Saver parts are installed on a bowl that is not a water saver bowl.
ROYAL: Replace dual filtered fixed bypass diaphragm assembly with appropriate Royal Performance Kit.
REGAL: Position Refill Head A-170 so SIDE 1 is in the UP position.
- Water supply volume or pressure is inadequate. If no gauges are available to properly measure supply pressure or water volume at flushometer, remove the relief valve from inside parts/diaphragm assembly. Reassemble flushometer and open the control stop. If the fixture siphons, more water volume is required.
IMPORTANT — LAWS AND REGULATIONS PROHIBIT THE USE OF HIGHER FLUSHING VOLUMES THAN LISTED ON FIXTURE OR FLUSHOMETER.
If fixture does not siphon or if a low consumption fixture is installed, or if the above steps do not yield satisfactory results, steps must be taken to increase the pressure and/or supply.

3. FLUSHOMETER CLOSSES OFF IMMEDIATELY. DIAPHRAGM OR BYPASS HOLE IS DAMAGED.

ROYAL: Replace Royal Performance Kit.

REGAL: Install new Inside Parts Kit.

4. LENGTH OF FLUSH IS TOO SHORT (SHORT FLUSHING).

ROYAL:

- Dual filtered fixed bypass diaphragm assembly is damaged. Replace Royal Performance Kit.
- Incorrect dual filtered fixed bypass diaphragm assembly is installed in flushometer. For instance, urinal assembly inside a closet flushometer, or Low Consumption assembly inside a higher consumption fixture. Determine the flush volume required by the fixture and replace Royal Performance Kit. Use valve label and markings on fixture for reference.

REGAL:

- Diaphragm assembly and guide assembly are not hand-tight. Screw the two assemblies hand-tight.
- By-pass orifice of diaphragm is enlarged from corrosion or damage. Install new inside parts kit.
- A black urinal relief valve is used in a closet flushometer. Replace the black A-19-AU urinal relief valve with a White A-19-AC closet relief valve.
- A Low Consumption Kit (A-41-A) is installed in a fixture that is not a Low Consumption fixture. Replace with suitable Inside Parts Kit.

5. LENGTH OF FLUSH IS TOO LONG (LONG FLUSHING) OR VALVE DOES NOT CLOSE.

- Relief Valve not seating properly or diaphragm by-pass orifice is clogged.
ROYAL: Remove dual filtered fixed bypass diaphragm assembly. Remove primary and secondary filter rings from the diaphragm and wash under running water. Replace Royal Performance Kit if cleaning does not correct the problem.
REGAL: Disassemble the working parts and wash thoroughly.
- NOTE: THE SIZE OF THE ORIFICE IN THE DIAPHRAGM BY-PASS DETERMINES THE PROPER METERING OF WATER INTO THE UPPER CHAMBER OF THE FLUSHOMETER. DO NOT ENLARGE OR DAMAGE THIS ORIFICE. REPLACE INSIDE PARTS KIT IF CLEANING DOES NOT CORRECT PROBLEM.**
- Decrease in line pressure does not force relief valve to seat. Shut off all control stops to restore pressure, then reopen stops.
 - White closet relief Valve has been used in a urinal flushometer. Replace closet relief valve (A-19-AC) with black urinal relief valve (A-19-AU).
 - Inside cover is cracked or damaged. Replace the Inside Cover (A-71).
 - ROYAL ONLY:** Incorrect dual filtered fixed bypass diaphragm assembly is installed in flushometer. For instance, closet assembly inside a urinal flushometer, or water saver assembly inside a low consumption flushometer. Determine flush volume required by the fixture and replace the Royal performance kit. Use valve label and markings on fixture for reference.

6. WATER SPLASHES OUT OF THE FIXTURE.

- The supply volume is too high. Throttle down the control stop.
- Lime has accumulated on the vortex or spreader holes of the fixture. Remove the lime accumulation.

7. THE FLUSH IS NOT CONSIDERED QUIET.

- The control stop may not be adjusted for quiet operation. Adjust the control stop for quiet operation while the flushometer is flushing, bearing in mind fixture requirements for proper siphonage.
- Conditions in the piping system may contribute to the noise level. A degree of high pressure in the piping may be relieved by adjustments to control stop. Other noises created by loose pipes, lack of air chambers, inadequate pipe sizes, etc., are problems that must be discussed with the building engineer.

8. CHATTERING NOISE IN FLUSHOMETER.

- The inside cover is distorted. Replace inside cover.
- REGAL ONLY:** The segment diaphragm has been installed upside-down. Replace the segment diaphragm (A-156-A) in the orientation indicated by markings on the Regal valve diaphragm.

**When further assistance is required, please contact your local Sloan Representative or the Sloan Technical Support at:
1-888-SLOAN-14 (1-888-756-2614)**

CARE AND CLEANING

DO NOT USE abrasive or chemical cleaners (including chlorine bleach) to clean flushometers that may dull the luster and attack the chrome or special decorative finishes. Use **ONLY** mild soap and water, then wipe dry with clean cloth or towel.

While cleaning the bathroom tile, protect the flushometer from any splattering of cleaner. Acids and cleaning fluids will discolor or remove chrome plating.

PARTS LIST

Item No.	Part No.	Description
1	†	Valve Body
2	H-730-A	RB Wheel Handle Bak-Chek® Control Stop
3	C-9-A	Blind Nut Push Button Actuator Assembly
4	A-31	Gasket
5	K-46	Gasket
6	A-6	Coupling
7A	HY-25	Valve Actuator Housing (only)
	HY-30	1/4" x 48" Connecting Tubes (two required)
7B	HY-83-A	Actuator Cartridge Assembly
7C	HY-100-A	Hydraulic Flushometer Push Button Actuator (MBFW Variation)
7D	HY-108-A	Hydraulic Flushometer Push Button Actuator (MBPM Variation)
8A	V-500-AA	3/4" (19 mm) x 10-1/2" (267 mm) Vacuum Breaker Assembly RB (Models 613 and 9613)
8B	V-500-AA	1-1/2" (38 mm) x 17-1/2" (445 mm) Vacuum Breaker Assembly RB (Model 601)
	V-500-AA	1-1/2" (38 mm) x 13" (330 mm) Vacuum Breaker Assembly RB (Models 603 and 9603)
	V-500-AA	1-1/2" (38 mm) x 11-1/2" (292 mm) Vacuum Breaker Assembly RB (Models 609 and 9609)
	V-500-AA	1-1/2" (38 mm) x 21" (533 mm) Vacuum Breaker Assembly RB (Model 611)
	V-500-AA	1-1/2" (38 mm) x 23" (584 mm) Vacuum Breaker Assembly RB (Model 681)
9	F-2-AA	1-1/2" (38 mm) Slip Joint Couplings (two per package)
10	F-2-AW	3/4" (19 mm) Slip Joint Coupling RB
11	F-15-A	ELL with 3/4" (19 mm) Tail RB
12	F-21	1-1/2" (38 mm) Double Slip Elbow
13	F-2-A	1-1/2" (38 mm) Coupling with S-21 Gasket
14	F-100	1-1/2" (38 mm) x 3-1/4" Flared End Flush Connection
Not Shown		LocTite Thread Sealant

† Part number varies with valve model variation; consult factory.

When assistance is required, please contact your local Sloan Representative or Sloan Technical Support at: 1-888-SLOAN-14 (1-888-756-2614)

Manufactured in the U.S.A. by Sloan Valve Company under one or more of the following patents: U.S. Pats. 5,295,655; 5,542,718; 5,558,120; 5,564,460; 5,865,420; 5,887,848; 5,967,182. Other Pats. Pending. BAK-CHEK, PARA-FLO, PERMEX, TURBO-FLO.

Standard Push Button Flushometer

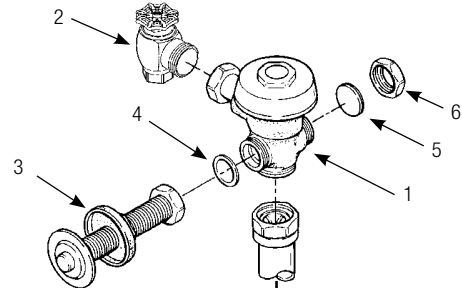

Hydraulic Push Button Flushometer

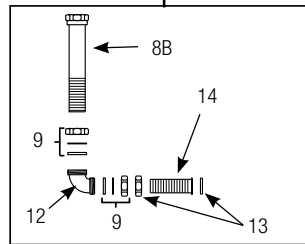
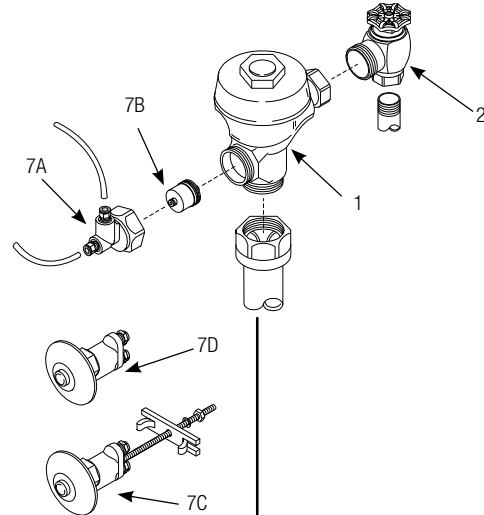

MODELS 601, 603, 609, 611, 681, 9603 and 9609

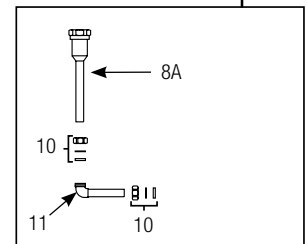

MODELS 613 and 9613

NOTE: The information contained in this document is subject to change without notice.

SLOAN HEADQUARTERS • 10500 SEYMOUR AVENUE • FRANKLIN PARK, IL 60131

Ph: 1-800-9-VALVE-9 or 1-800-982-5839 • Fax: 1-800-447-8329 • www.sloanvalve.com