

## INSTALLATION INSTRUCTIONS FOR EXPOSED REGAL® XL WATER CLOSET AND URINAL FLUSHOMETERS

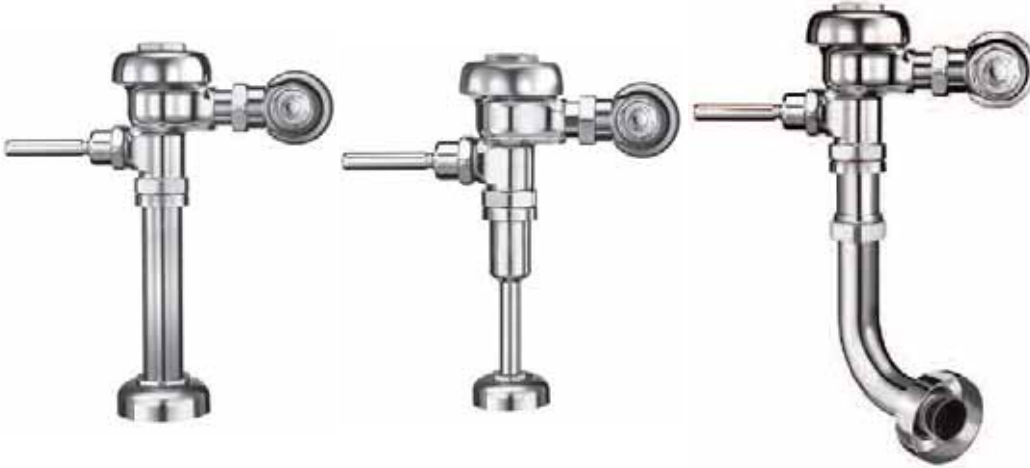

- Closet Flushometer  
1½" (38 mm) Top Spud  
MODELS 110/111,  
113, 115 & 116
- Closet Flushometer  
1½" (38 mm) Back Spud  
MODEL 120 & 122
- Service Sink Flushometer  
1½" (38 mm) Top Spud  
MODEL 117
- Urinal Flushometer  
1¼" (32 mm) Top Spud  
MODEL 180
- Urinal Flushometer  
¾" (19 mm) Top Spud  
MODEL 186
- Squat Toilet Flushometer  
1½" (38 mm) Back Spud  
MODEL 137

### LIMITED WARRANTY

Sloan Valve Company warrants its Regal XL Flushometers to be made of first class materials, free from defects of material or workmanship under normal use and to perform the service for which they are intended in a thoroughly reliable and efficient manner when properly installed and serviced, for a period of three years (1 year for special finishes) from date of purchase. During this period, Sloan Valve Company will, at its option, repair or replace any part or parts which prove to be thus defective if returned to Sloan Valve Company, at customer's cost, and this shall be the sole remedy available under this warranty. No claims will be allowed for labor, transportation or other incidental costs. This warranty extends only to persons or organizations who purchase Sloan Valve Company's products directly from Sloan Valve Company for purpose of resale.

**THERE ARE NO WARRANTIES WHICH EXTEND BEYOND THE DESCRIPTION ON THE FACE HEREOF. IN NO EVENT IS SLOAN VALVE COMPANY RESPONSIBLE FOR ANY CONSEQUENTIAL DAMAGES OF ANY MEASURE WHATSOEVER.**

### PRIOR TO INSTALLATION

Before you install the Regal XL Flushometer, be sure the items listed below are installed. Also, refer to the rough-in diagrams on the next page.

- Closet or urinal fixture
- Drain line
- Water supply line

**Important:**

- **INSTALL ALL PLUMBING IN ACCORDANCE WITH APPLICABLE CODES AND REGULATIONS.**
- **WATER SUPPLY LINES MUST BE SIZED TO PROVIDE AN ADEQUATE VOLUME OF WATER FOR EACH FIXTURE.**
- **FLUSH ALL WATER LINES PRIOR TO MAKING CONNECTIONS.**

The Sloan Regal XL Flushometer is designed to operate with 10 to 100 psi (69 to 689 kPa) of water pressure. **THE MINIMUM PRESSURE REQUIRED TO THE VALVE IS DETERMINED BY THE TYPE OF FIXTURE SELECTED.** Consult fixture manufacturer for minimum pressure requirements. Most Low Consumption water closets (1.6 gpf/6.0 Lpf) require a minimum flowing pressure of 25 psi (172 kPa).

### TOOLS REQUIRED FOR INSTALLATION

- Straight blade screwdriver
- Sloan A-50 Super-Wrench™, Sloan A-109 Plier Wrench or smooth jawed spud wrench

# VALVE ROUGH-INS

MODELS 110/111

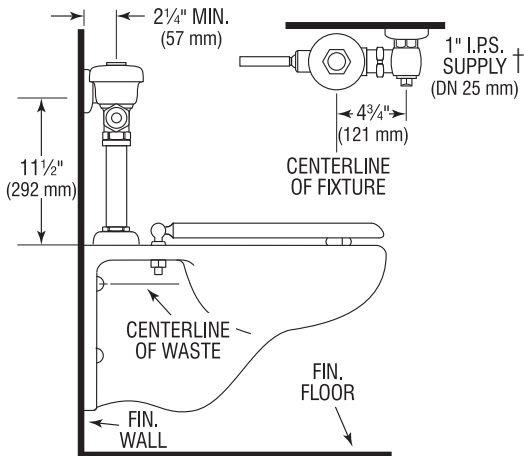

MODELS 113, 115 & 116

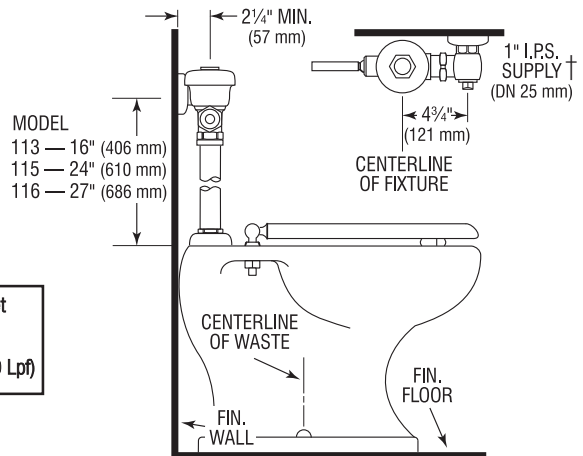

NOTE: Water Closet Valves with "-2.4" Model Designation deliver 2.4 gpf (9.0 Lpf)

MODEL 117

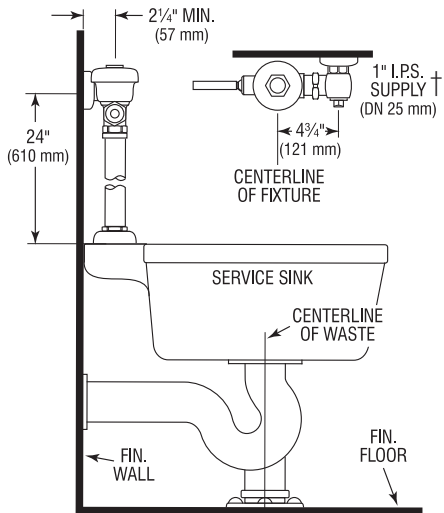

MODELS 120/122

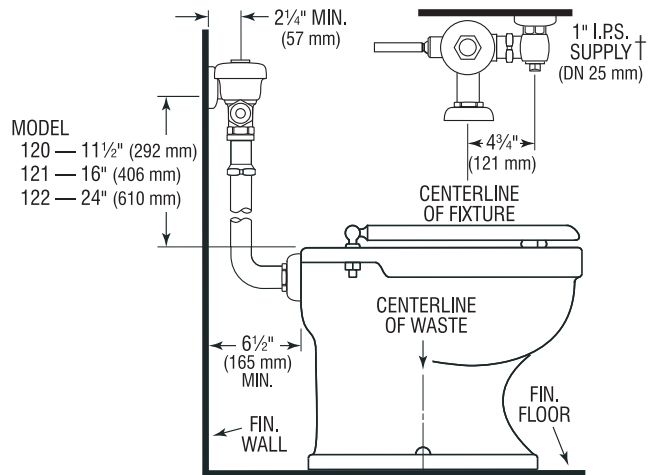

MODEL 180

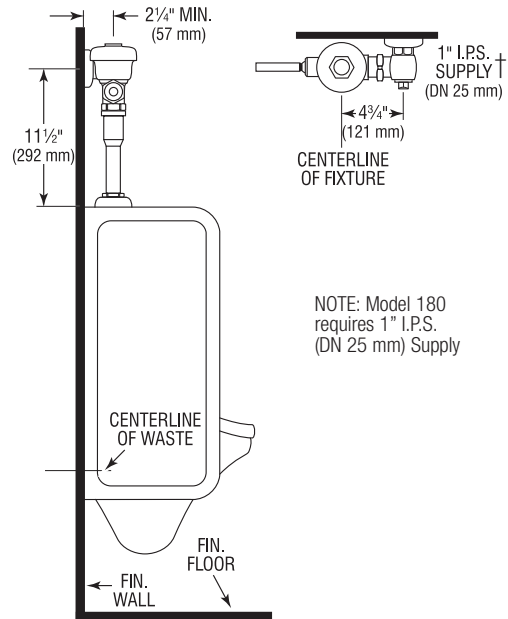

NOTE: Model 180 requires 1" I.P.S. (DN 25 mm) Supply

MODEL 186

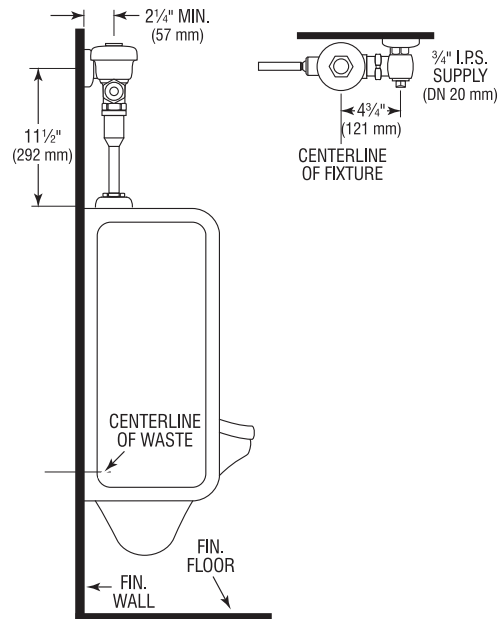

† 1" Control Stop is available with Whitworth Thread

**IMPORTANT NOTES:**

- When mounted on an ADA accessible bowl, the rough-in to the supply inlet should be no higher than 37 1/2" or the handle will exceed maximum height allowances under ADA guidelines.
- New ADAAG Guidelines allow for Split or Offset Grab Bars, check with local authorities or reference section 604.5.2 of ADAAG.

**!!! IMPORTANT !!!**

With the exception of Control Stop Inlet, **DO NOT** use pipe sealant or plumbing grease on any valve component or coupling!

**!!! IMPORTANT !!!**

Protect the chrome or special finish of Sloan Flushometers — **DO NOT USE** toothed tools to install or service these valves. Use a Sloan A-50 Super-Wrench™, Sloan A-109 Plier Wrench or smooth jawed spud wrench to secure all couplings. Also see "Care and Cleaning" section of this manual.

**!!! IMPORTANT !!!**

This product contains mechanical and/or electrical components that are subject to normal wear. These components should be checked on a regular basis and replaced as needed to maintain the valve's performance.

**!!! IMPORTANT !!!**

Never open Control Stop to where the flow from the valve exceeds the flow capability of the fixture. In the event of a valve failure, the fixture must be able to accommodate a continuous flow from the valve.

Please take the time to read this manual to ensure proper product installation and longevity. Also, please visit our website to download our most recent documentation for this product.

If you have questions about how to install your Flushometer, consult your local Sloan Representative or call Sloan Installation Engineering Department at:

**1-888-SLOAN-14 (1-888-756-2614)**

## 1 - INSTALL SWEAT SOLDER ADAPTER (ONLY IF YOUR SUPPLY PIPE DOES NOT HAVE A MALE THREAD)

- A** Measure from finished wall to C/L of Fixture Spud. Cut pipe 1 1/4" (32 mm) shorter than this measurement. Chamfer O.D. and I.D. of water supply pipe.
- B** Slide Threaded Adapter fully onto pipe.
- C** Sweat solder the Adapter to pipe.

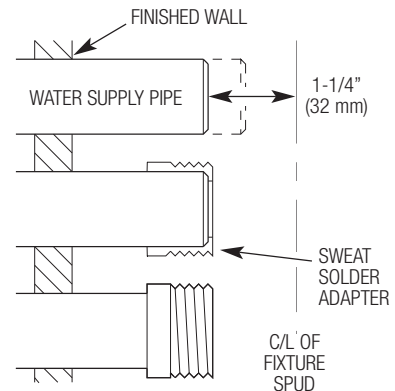

## 2 - INSTALL COVER TUBE, WALL FLANGE AND CONTROL STOP TO SUPPLY PIPE AND INSTALL VACUUM BREAKER FLUSH CONNECTION

- A** Measure from finished wall to first thread of Adapter or threaded supply pipe (dimension "X"). Cut Cover Tube to this length.
- B** Slide Cover Tube over pipe. Slide Wall Flange over Cover Tube until against wall.
- C** Thread Control Stop onto pipe. Tighten with a wrench making sure outlet is positioned as required.

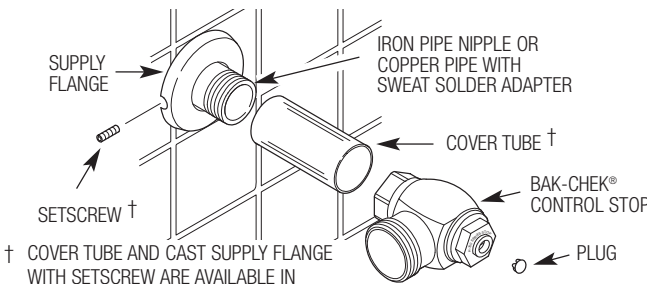
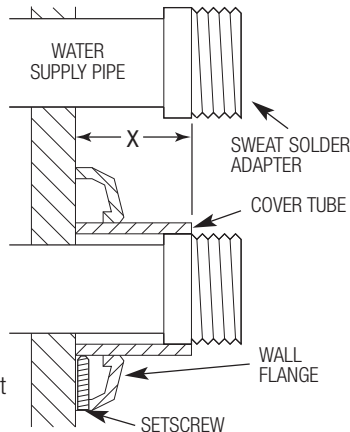

† COVER TUBE AND CAST SUPPLY FLANGE WITH SETSCREW ARE AVAILABLE IN "YBYC" SWEAT SOLDER KIT.

- D** Tighten Setscrew with a 1/16" hex wrench. **DO NOT** install Vandal Resistant Plug at this time.

- E** Slide Spud Coupling, Nylon Slip Gasket, Rubber Gasket and Spud Flange over Vacuum Breaker Tube.

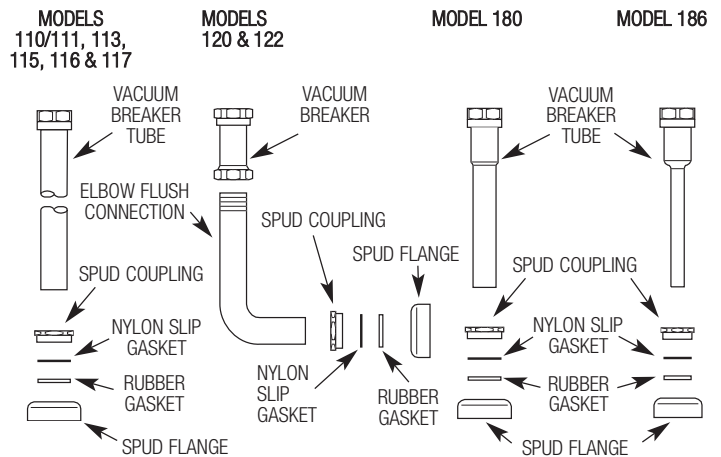

- F** Insert Tube into Fixture Spud.
- G** Hand tighten Spud Coupling onto Fixture Spud.

### 3 - INSTALL FLUSHOMETER AND HANDLE ASSEMBLY

- A** Lubricate tailpiece O-ring with water. Insert Adjustable Tailpiece into Control Stop. Tighten Tailpiece Coupling by hand.
- B** Align Flushometer directly above the Vacuum Breaker Flush Connection by sliding the Flushometer Body IN or OUT as needed. Tighten Vacuum Breaker Coupling by hand.



**NOTE**

Maximum adjustment of the Sloan Adjustable Tailpiece is 1/2" (13 mm) IN or OUT from the standard 4-3/4" (121 mm) (centerline of Flushometer to centerline of Control Stop).  
 If roughing-in measurement exceeds 5-1/4" (133 mm), consult factory for longer tailpiece.

- C** Align Flushometer Body. Using a wrench, securely tighten couplings in the order given: (1) Tailpiece Coupling, (2) Vacuum Breaker Coupling and (3) Spud Coupling.

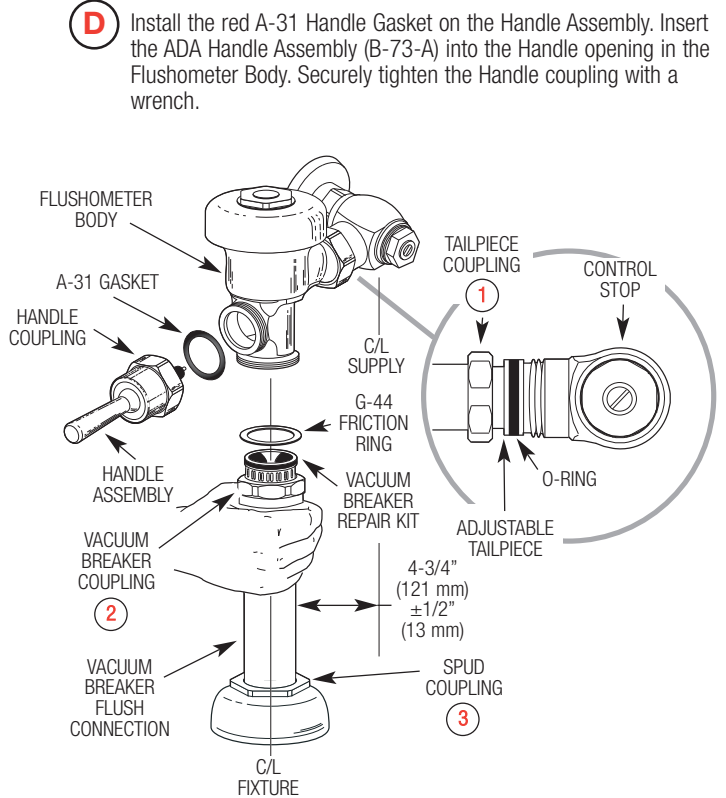

### 4 - FLUSH OUT SUPPLY LINE

- A** Make sure Control Stop is CLOSED and remove Flushometer Outer Cover.
- B** Remove Inside Cover and lift out Inside Parts Assembly.

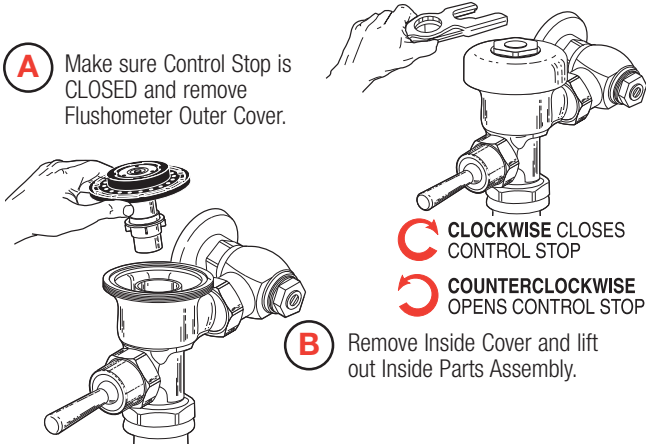

- C** Reinstall Outside and Inside Cover wrench tight. Open Control Stop to flush supply line. Close Control Stop and remove Outside and Inside Cover.
- D** Reinstall Inside Parts Assembly, Inside Cover and Outside Cover wrench tight.

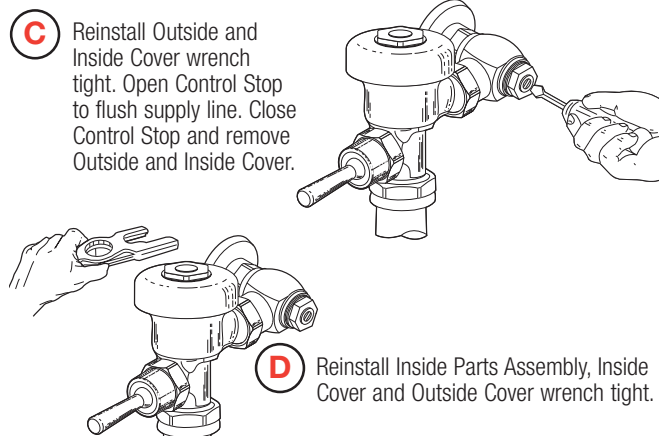

### 5 - ADJUST CONTROL STOP AND INSTALL PLUG

- A** Open Control Stop COUNTERCLOCKWISE one FULL turn from closed position.
- B** Activate Flushometer.
- C** Adjust Control Stop after each flush until the rate of flow delivered properly cleanses the fixture.

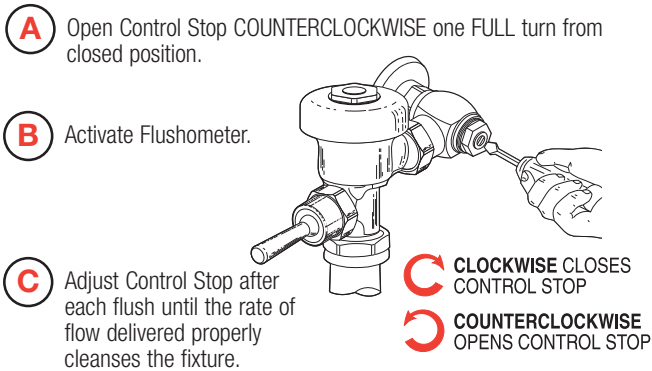

**!!! IMPORTANT !!!**

The Regal XL Flushometer is engineered for quiet operation. Excessive water flow creates noise, while too little water flow may not satisfy the needs of the fixture. Proper adjustment is made when the plumbing fixture is cleansed after each flush without splashing water out from the lip AND a quiet flushing cycle is achieved.  
 Never open Control Stop to where the flow from the valve exceeds the flow capability of the fixture. In the event of a valve failure, the fixture must be able to accommodate a continuous flow from the valve.

- D** Install Plug into the Control Stop by pressing into Bonnet.



## CARE AND CLEANING

**DO NOT USE** abrasive or chemical cleaners (including chlorine bleach) to clean Flushometers that may dull the luster and attack the chrome or special decorative finishes. Use **ONLY** mild soap and water, then wipe dry with clean cloth or towel.

While cleaning the bathroom tile, protect the Flushometer from any splattering of cleaner. Acids and cleaning fluids will discolor or remove chrome plating.



## TROUBLESHOOTING GUIDE

### I. Flushometer does not function (no flush).

- Control Stop or Main Valve is Closed. Open Control Stop or Main Valve.
- Handle Assembly is damaged. Replace Handle (B-32-A or B-73-A) or install Handle Repair Kit (B-50-A).
- Relief Valve is damaged. Replace Inside Parts Kit.

### 2. Volume of water is not sufficient to siphon fixture.

- Control Stop is not open wide enough. Adjust Control Stop for desired delivery of water volume.
- Urinal Flushometer Parts inside a Closet Flushometer. Replace Inside Urinal Parts with proper Closet Flushometer Parts.
- Low Consumption Flushometer installed on a non-Low Consumption fixture. Replace A-41-A Inside Parts Kit with A-38-A Water Saver Kit.
- Water Saver Kit installed in old, non-Water Saver bowl. Position Refill Head A-170 so that SIDE 1 is in the UP Position.
- Inadequate volume or pressure at supply.
  - If no gauges are available to properly measure supply pressure or volume of water at the Flushometer, then remove the Relief Valve from the Inside Parts Kit, reassemble the Flushometer and open the Control Stop. If the fixture siphons, more water volume is required. If a 3.5 gpf Inside Parts Kit is installed in the Flushometer, then first flip the Refill Head (under the Diaphragm) to obtain a 4.5 gpf volume. If this volume is still inadequate, remove the Flow Ring from the Guide to obtain a 6.5 gpf Kit. If additional flow is still required, try a Low Pressure Guide Kit A-175-A (#0301104). **IMPORTANT — Laws and Regulations requiring Low Consumption Fixtures (1.6 gpf Water Closets and 1.0 gpf Urinals) prohibit the use of higher flushing volumes.**
  - If fixture does not siphon or if a Low Consumption fixture is installed, or if the above steps do not prove satisfactory, steps must be taken to increase the pressure and/or supply.

### 3. Flushometer closes off immediately.

- Ruptured or damaged Diaphragm. Install Inside Parts Kit to correct problem and update Flushometer.
- Enlarged By-Pass orifice from corrosion or damage. Install Inside Parts Kit to correct problem and update Flushometer.

### 4. Length of flush is too short (short flush).

- Diaphragm Assembly and Guide Assembly are not hand-tight. Screw the two assemblies hand-tight.
- Enlarged By-pass orifice from corrosion or damage. Install NEW Inside Parts Kit to correct problem and update Flushometer.
- A-19-AU (Black) Urinal Relief Valve in Closet flushometer. Replace Relief Valve with A-19-AC (White) Closet Relief Valve.
- A-41-A Low Consumption Kit installed in non-Low Consumption fixture. Replace with proper Inside Parts Kit.
- Handle Assembly is damaged. Replace Handle (B-32-A or B-73-A) or install Handle Repair Kit (B-50-A).

### 5. Length of flush is too long (Long Flushing) or fails to close off.

- Relief Valve (A-19-A) is not seating properly or By-pass orifice is clogged because of foreign material, or By-pass orifice is closed by an invisible gelatinous film from "over-treated" water. Disassemble the working parts and wash thoroughly.  
**NOTE: SIZE OF THE ORIFICE IN THE BY-PASS IS OF UTMOST IMPORTANCE FOR THE PROPER METERING OF WATER INTO THE UPPER CHAMBER OF THE FLUSHOMETER. DO NOT ENLARGE OR DAMAGE THIS ORIFICE. REPLACE INSIDE KIT IF CLEANING DOES NOT CORRECT PROBLEM.**
- Line pressure has dropped and is not sufficient to force Relief Valve to seat. Shut off all control stops until pressure has been restored, then open them again.
- A-19-AC (White) Closet Relief Valve has been used in a 1 or 1½ gpf Urinal. Replace with A-19-AU (Black) Relief Valve.
- Inside Cover is cracked or damaged. Replace the Inside Cover (A-71).

### 6. Chattering noise is heard during flush.

- Inside Cover is damaged. Replace Inside Cover (A-71).
- A-156-A Segment Diaphragm has been installed upside-down. Reposition the Segment Diaphragm properly (see markings on the Diaphragm).

### 7. Handle Leaks.

- B-39 Handle Seal is worn or damaged. Install new B-39 Seal.  
**NOTE: The B-39 Seal will easily slide onto the B-40 Bushing when wet.**
- Handle gasket has been omitted. Install Handle Gasket (A-31) or Sloan Handle Repair Kit (B-50-A).
- Valve Handle Bushing is worn. Replace Handle Repair Kit (B-50-A).

Refer to the Regal XL Flushometer Maintenance Guide for additional Troubleshooting and Repair Part information.

When assistance is required, please contact Valve Company Installation Engineering Department at:

**1-888-SLOAN-14 (1-888-756-2614) or 1-847-233-2016**

## PARTS LIST

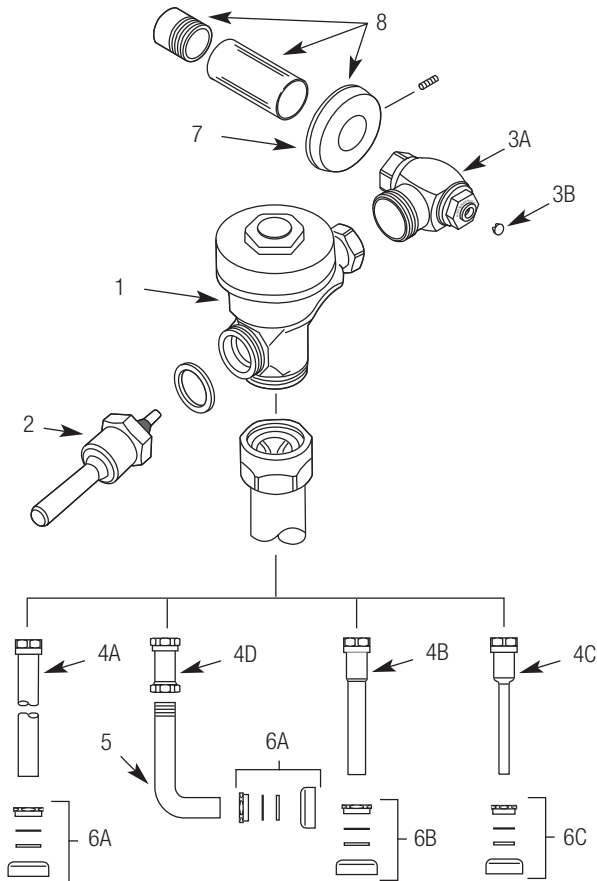

Item No.	Part No.	Description
1	†	Valve Assembly
2	B-73-A	ADA Compliant Handle Assembly
3A	H-790-A	Bak-Chek® Control Stop
3B	H-528	Control Stop Bonnet Plug
4A	V-500-AA	1½" (38 mm) x 9" (229 mm) Vacuum Breaker Assembly ‡
4B	V-500-AA	1¼" (32 mm) x 9" (229 mm) Vacuum Breaker Assembly
4C	V-500-AA	¾" (19 mm) x 9" (229 mm) Vacuum Breaker Assembly
4D	V-500-A	Vacuum Breaker Assembly
5	F-109	1½" (38 mm) Elbow Flush Connection ‡
6A	F-56-A	1½" (38 mm) Spud Coupling Assembly
6B	F-57-A	1¼" (32 mm) Spud Coupling Assembly
6C	F-58-A	¾" (19 mm) Spud Coupling Assembly
7	F-7	Supply Flange (Supplied when Valve is Not Ordered with Sweat Solder Kit)
8	H-633-AA	1" (25 mm) Sweat Solder Kit and Cast Wall Flange with Setscrew
	H-636-AA	¾" (19 mm) Sweat Solder Kit and Cast Wall Flange with Setscrew

† Part number varies with valve model variation; consult factory  
‡ Length varies with valve model variation; consult factory

## REPAIR KITS

### INSIDE PARTS KIT FOR SLOAN REGAL® XL FLUSHOMETERS

#### REPAIR KIT SELECTION GUIDE

Kit No.	Flush Volume	"Used On"
A-36-A	4.5 gpf (17.0 Lpf)	Very old Water Closets, primarily Blow Outs
A-37-A	1.5 gpf (5.7 Lpf)	Older Siphon Jet and some Blow Out Urinals
A-38-A	3.5 gpf (13.2 Lpf)	Water Saver Water Closets and old Blow Out Urinals *
A-41-A	1.6 gpf (6.0 Lpf)	Low Consumption Water Closets †
A-42-A	1.0 gpf (3.8 Lpf)	Low Consumption Urinals (Siphon Jet and Blow Out)
A-43-A	0.5 gpf (1.9 Lpf)	Wash Down Urinals only ‡
A-44-A	2.4 gpf (9.0 Lpf)	European and Asian Style 9 Liter Water Closets

\* Includes newer Blow Out Water Closets

† Low Consumption Water Closets are marked "1.6 gpf" or "6.0 Lpf"

‡ Some Wash Down Urinals may require a 1.0 gallon (3.8 Liter) flush

#### REGAL® XL VALVE REPAIR KITS §

Kit No.	Flush Volume	"Used On"
R-1001-A	4.5 gpf (17.0 Lpf)	Water Closets
R-1002-A	1.5 gpf (5.7 Lpf)	Urinals
R-1003-A	3.5 gpf (13.2 Lpf)	Water Closets
R-1004-A	1.6 gpf (6.0 Lpf)	Water Closets
R-1005-A	1.0 gpf (3.8 Lpf)	Urinals
R-1011-A	0.5 gpf (1.9 Lpf)	Urinals
R-1012-A	2.4 gpf (9.0 Lpf)	Water Closets

§ Kit includes:

- A Inside Parts Kit
- B Handle Repair Kit
- C Vacuum Breaker Repair Kit
- D Tailpiece "O" Ring

NOTE: The information contained in this document is subject to change without notice.

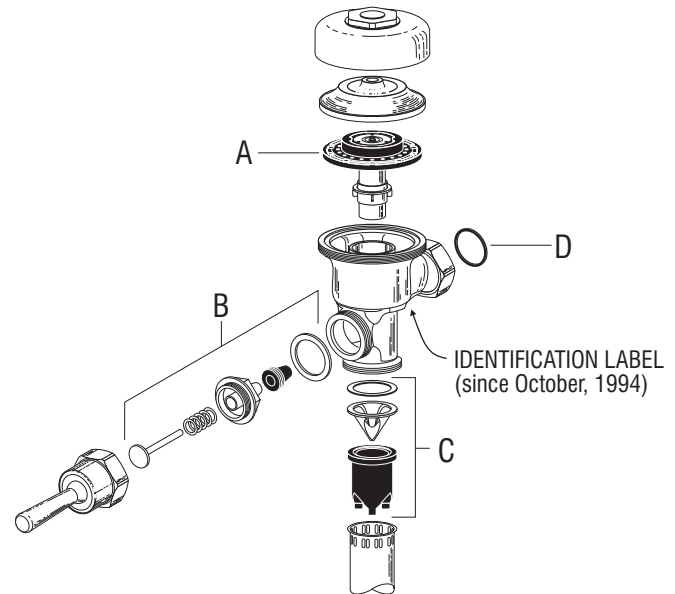

#### SPECIAL NOTE

For Service Sinks which require a 6.5 gpf (24.6 Lpf), use Sloan Repair Kit No. A-36-A and remove Flow Ring before installing.

For a complete listing of Flushometer Valve components and Repair Kits, see the Regal Maintenance Guide or consult your nearest Plumbing Wholesaler.

For optimum water conservation and Flushometer performance, use only Genuine Sloan Parts.

**SLOAN**

Copyright © 2010 SLOAN VALVE COMPANY

SLOAN VALVE COMPANY • 10500 Seymour Avenue • Franklin Park, IL 60131  
Ph: 1-800-982-5839 or 1-847-671-4300 • Fax: 1-800-447-8329 or 1-847-671-4380

www.sloanvalve.com  
Code No: 0816312 - Rev. 1 (05/10)