

PRODUCT SUBMITTAL 325

Product: EVERLOC[®] Bullhead Tees
Date: 25-August-09 (supersedes, 01-October-07)

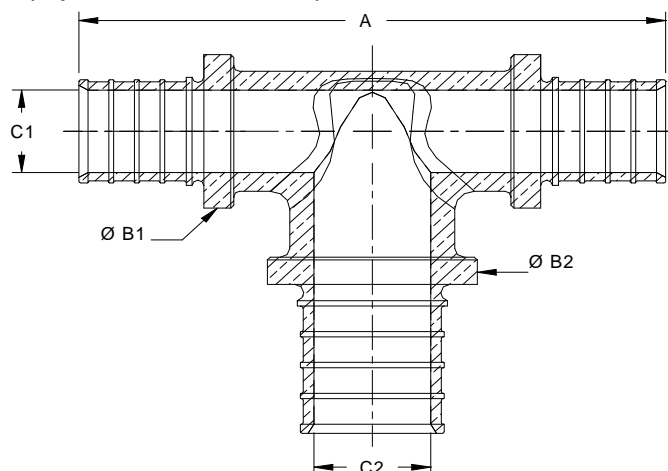

Article No.	Nominal Size	A in. (mm)	B1 in. (mm)	B2 in. (mm)	C1 in. (mm)	C2 in. (mm)
260857-101*	1/2" x 1/2" x 3/4" EVERLOC Tee	3.414 (86.7)	0.856 (21.7)	1.112 (28.2)	0.398 (10.1)	0.598 (15.2)
260897-101*	3/4 x 3/4" x 1" EVERLOC Tee	3.878 (98.5)	1.112 (28.2)	1.388 (35.2)	0.598 (15.2)	0.772 (19.6)

TECHNICAL DESCRIPTION

Specification	ASTM F 2080 / F 877
Material	Hot Forged From Solid Brass
Certifications	ASTM F 877 / F 2080 / NSF-rfh

FUNCTIONAL DESCRIPTION

EVERLOC compression-sleeve fittings are ideal for heating, snow and ice melting, hydronic radiator connections, when used with REHAU's RAUPEX[®] PEXa pipes. EVERLOC fittings and compression-sleeves ("sleeves") create reliable connections that can be walled in, including applications above the ceiling (check for local code compliance). EVERLOC straight fittings are machined from solid brass rod.

Installation is performed with EVERLOC tools. Follow all published installation instructions. Order EVERLOC sleeves separately.

For updates to this publication, visit na.rehau.com/resourcecenter

The information contained herein is believed to be reliable, but no representations, guarantees or warranties of any kind are made as to its accuracy, suitability for particular applications or the results to be obtained therefrom. Before using, the user will determine suitability of the information for user's intended use and shall assume all risk and liability in connection therewith. To the extent permitted by law, REHAU EXPRESSLY DISCLAIMS ALL IMPLIED WARRANTIES, INCLUDING BUT NOT LIMITED TO, ANY IMPLIED WARRANTIES OF MERCHANTABILITY OR OF FITNESS FOR A PARTICULAR PURPOSE.

© REHAU Incorporated 2009