

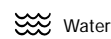

The new degree of comfort.™



Residential Gas
Prestige RTGH Tankless Water Heaters

Rheem *Prestige*™ RTGH is a series of high efficiency condensing tankless gas water heaters designed for continuous hot water

Efficiency

- Up to .94 EF with stainless steel condensing heat exchanger
- Intelligent electronic controls designed to increase energy efficiency and safety
- Third party efficiency listed by AHRI

Performance

- Industry First! 0.26 GPM minimum flow rate, 0.40 GPM minimum activation flow rate
- SCAQMD rule 1146.2 compliant
- RTGH-95 for 3 bathroom homes*– 9.5 gal./min. at 35°F rise max., 8.4 gal./min. at 45°F rise
- RTGH-90 for 2-3 bathroom homes*– 9.0 gal./min. at 35°F rise max., 7.5 gal./min. at 45°F rise
- RTGH-84 for 2-3 bathroom homes*– 8.4 gal./min. at 35°F rise max., 6.6 gal./min. at 45°F rise

Compact Size

- Compact space-saving design – about the size of a medicine cabinet

Self-Diagnostic System

- Self-diagnostic system for easy installation and service.
- Digital display shows temperature setting and maintenance codes

Technology

- Two-pipe direct vent system designed for PVC pipe (up to 38 ft. of 3" PVC Pipe or 5 ft. of 2" PVC Pipe). See instructions for details
- Hot-start programming helps minimize fluctuation in water temperature, referred to as "cold water sandwich effect," during periods of frequent on/off operation
- Built-in electric blower
- Exclusive! Guardian OFW™ overheat film wrap
- EZ-Link™ cable available for higher demand applications to connect two tankless units to operate as one
- Manifold up to six units with an optional MIC-6 manifold control board
- Manifold up to 20 units with the optional MIC-185 plus the MICS-180 manifold control assembly

High-Altitude Compliant

- High-altitude capability – up to 9,840 ft. elevation above sea level

Plus...

- Digital remote control and 10 ft. of thermostat wire included
- Supplied with a 120-volt power cord (indoor models only)
- Freeze protection to -30°F
- Required manual gas isolation valve included
- EZ- Spec™ Sizing Software – advanced online tool that takes the guess work out of sizing tankless applications – available at www.rheem.com/tankless

Warranty

- 12-Year heat exchanger – residential, 5-year heat exchanger – commercial, 5-year parts and 1-year labor

See Warranty Certificate for complete information

Commercial Applications

The RTGH Condensing Tankless Series can be upgraded for high-temperature commercial use.

- Temperature range is 85°F to 185°F

RTGH-95 Upgrade Kits

RTG20240A for RTGH-95DVLN
 RTG20240B for RTGH-95DVLPLP
 RTG20240C for RTGH-95XLN
 RTG20240D for RTGH-95XLP

RTGH-90 Upgrade Kits

RTG20244A for RTGH-90DVLN
 RTG20244B for RTGH-90DVLPLP
 RTG20244C for RTGH-90XLN
 RTG20244D for RTGH-90XLP

RTGH-84 Upgrade Kits

RTG20241A for RTGH-84DVLN
 RTG20241B for RTGH-84DVLPLP
 RTG20241C for RTGH-84XLN
 RTG20241D for RTGH-84XLP

Note: These upgrade kits are not compatible with previous models. See the Tankless Parts and Accessories Catalog for a complete listing.

* Based on simultaneous showers using 2.5 gallons per minute. Flow rates vary depending on temperature of cold water supply.



RTGH-DVL

Indoor Direct Vent Model
11,000-199,900 Btu/h
Natural and LP Gas



RTGH-XL

Outdoor Model
11,000-199,900 Btu/h
Natural and LP Gas



LEED Points = 2

myrheem.com/proclub



INTEGRATED HOME COMFORT



The new degree of comfort.™



Residential Gas
Prestige RTGH Tankless Water Heaters

Rheem Prestige™ Specifications

DESCRIPTION			FEATURES					ROUGHING IN DIMENSIONS (SHOWN IN INCHES)							ENERGY INFO.		
MODEL NUMBER	GAS INPUT BTU/H	TYPE	TEMP. RANGE	MIN. FLOW/ACTIVATION GPM	GPM @ 77° RISE MAX.	GPM @ 45° RISE MAX.	MAX. GPM	CONNECTION		HEIGHT	WIDTH	DEPTH	VENT DIAM.	SHIP WEIGHT (LBS.)	ENERGY FACTOR	RECOVERY EFFICIENCY	EST. YEARLY ENERGY COST NAT/LP
Rheem Prestige™ RTGH-95 for 3 Bathroom Homes																	
RTGH-95DVLN	11,000-199,900	Indoor Direct Vent	85° to 140° F	0.26/0.40	4.9	8.4	9.5	3/4	3/4	27-1/2	18-1/2	9-3/4	2" or 3" PVC 2-Pipe	82	.94	94%	\$174/421
RTGH-95XLN	11,000-199,900	Outdoor	85° to 140° F	0.26/0.40	4.9	8.4	9.5	3/4	3/4	27-1/2	18-1/2	9-3/4	N/A	82	.94	94%	\$174/421
Rheem Prestige™ RTGH-90 for 2-3 Bathroom Homes																	
RTGH-90DVLN	11,000-180,000	Indoor Direct Vent	85° to 140° F	0.26/0.40	4.4	7.5	9	3/4	3/4	27-1/2	18-1/2	9-3/4	2" or 3" PVC 2-Pipe	82	.93	93%	\$176/425
RTGH-90XLN	11,000-180,000	Outdoor	85° to 140° F	0.26/0.40	4.4	7.5	9	3/4	3/4	27-1/2	18-1/2	9-3/4	N/A	82	.93	93%	\$176/425
Rheem Prestige™ RTGH-84 for 2-3 Bathroom Homes																	
RTGH-84DVLN	11,000-157,000	Indoor Direct Vent	85° to 140° F	0.26/0.40	3.9	6.6	8.4	3/4	3/4	27-1/2	18-1/2	9-3/4	2" or 3" PVC 2-Pipe	82	.92	92%	\$178/430
RTGH-84XLN	11,000-157,000	Outdoor	85° to 140° F	0.26/0.40	3.9	6.6	8.4	3/4	3/4	27-1/2	18-1/2	9-3/4	N/A	82	.92	92%	\$178/430

Estimated energy cost based on a national average fuel cost of \$1.09/therm for natural gas and \$2.41/gallon for LP. Energy factor determined by the U.S. Department of Energy (DOE) test procedures.

All models are available in Natural Gas and Propane (LP). For Propane replace the N with P when ordering.

- SCAQMD 1146.2 compliant.
- Factory set maximum temperature is 120° F. See Use and Care Manual for setting.
- Consult factory for information on sizing the application.
- Add a "C" to the model number when ordering Canadian models. Outdoor models are only for seasonal use in Canada. Please contact Rheem Canada Ltd. for details.

Vent Termination Kits are required for Direct Vent models. Contact your distributor for details.

Proper gas pressure must be ensured to supply tankless gas water heaters – up to 199,900 Btu/h for RTGH-95 models, up to 180,000 Btu/h for RTGH-90 models, up to 157,000 Btu/h for RTGH-84 models. (Consult your gas supplier)

Model Number	Temperature Rise (° F)									
	35°	45°	50°	60°	70°	77°	80°	90°	100°	
RTGH-95 Water Flow (GPM)	9.5	8.4	7.6	6.3	5.4	4.9	4.7	4.2	3.8	
RTGH-90 Water Flow (GPM)	9.0	7.5	6.8	5.6	4.8	4.4	4.2	3.8	3.4	
RTGH-84 Water Flow (GPM)	8.4	6.6	6.0	5.0	4.3	3.9	3.7	3.3	3.0	

Above estimates are for sizing purposes only.

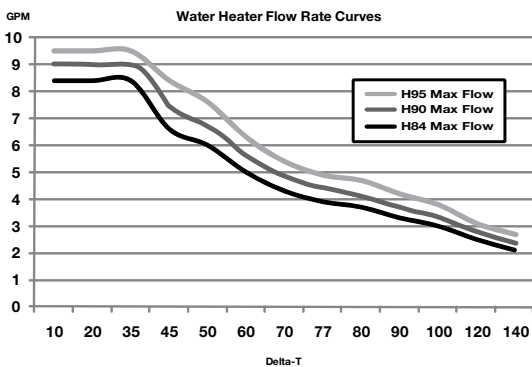

Maximum Vent Length (intake/outlet):

Number of 90° Elbows	Maximum Length of 2" Straight Pipe	Maximum Length of 3" Straight Pipe
0 or 1	5.0 ft. (1.5 m)	38.0 ft. (11.6 m)
2	3.5 ft. (1.0 m)	36.5 ft. (11.1 m)
3	2.0 ft. (0.6 m)	35.0 ft. (10.6 m)
4	Not Available	33.5 ft. (10.2 m)
5	Not Available	32.0 ft. (9.8 m)
6	Not Available	30.5 ft. (9.3 m)

(ULCs636 pipe must be used for Canada.)

Parts and Accessories

Venting & terminations – 2" or 3" PVC, recess boxes, pipe covers, extra remote controls, EZ-Link™ cable, manifolds and cables, service valve kits, service parts and flush kits.

For more information on Tankless parts and accessories, see the Parts and Accessories Catalog or call 866-720-2076.

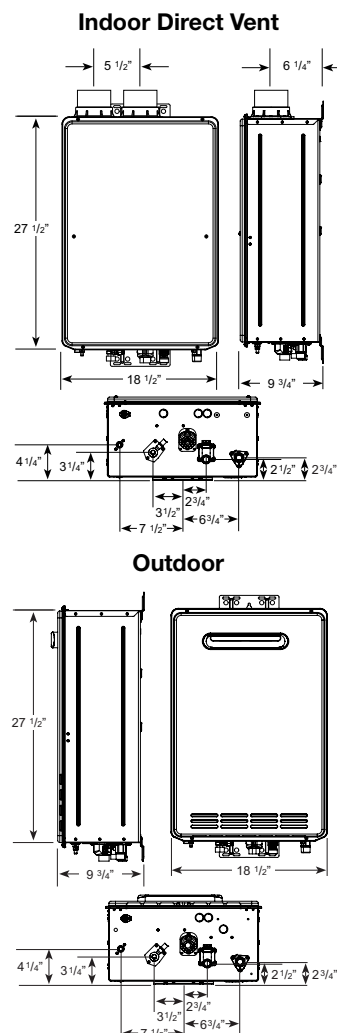

In keeping with its policy of continuous progress and product improvement, Rheem reserves the right to make changes without notice.

Rheem Water Heating • 101 Bell Road
Montgomery, Alabama 36117-4305 • www.rheem.com

Rheem Canada Ltd./Ltée • 125 Edgeware Road, Unit 1
Brampton, Ontario L6Y 0P5 • www.rheem.com



INTEGRATED HOME COMFORT