



The new degree of comfort.™

Rheem *Commercial Classic*® Series Package Heat Pump



RJNL-B High Efficiency Series

Nominal Sizes 7.5 & 10 Tons [26.4 & 35.2 kW]
ASHRAE 90.1-2010 Compliant Models





TABLE OF CONTENTS

Unit Features & Benefits	3-7
Model Number Identification	8
Options	9
Selection Procedure	10
General Data	
RJNL-B Series	11-14
General Data Notes	15
Gross Systems Performance Data	
RJNL-B Series	16-17
Airflow Performance	
RJNL-B Series	18-19
Electric Heater Kits	20-22
Electrical Data	
RJNL-B Series	23-24
Dimensional Data	25-28
Accessories	29-50
Mechanical Specifications	51-52
Wiring Diagrams	53-55
Limited Warranty	56



RJNL-B STANDARD FEATURES INCLUDE:

- R-410A HFC refrigerant.
- Complete factory charged, wired and run tested.
- Scroll compressors with internal line break overload and high-pressure protection.
- Convertible airflow.
- TXV refrigerant metering system.
- High Pressure and Low Pressure/Loss of charge protection standard on all models.
- Solid Core liquid line filter drier.
- Cooling operation up to 125 degree F ambient.
- Foil faced insulation encapsulated throughout entire unit minimizes airborne fibers from the air stream.
- Hinged major access door with heavy-duty gasketing, 1/4 turn latches and door retainers.
- Slide Out Indoor fan assembly for added service convenience.
- Powder Paint Finish meets ASTM B117 steel coated on each side for maximum protection. G90 galvanized.
- One piece top cover and one piece base pan with drawn supply and return opening for superior water management.
- Forkable base rails for easy handling and lifting.
- Single point electrical connections.
- Internally sloped slide out condensate pan conforms to ASHRAE 62 standards.
- High performance belt drive motor with variable pitch pulleys and quick adjust belt system.
- Permanently lubricated evaporator, condenser and gas heat inducer motors.
- Condenser motors are internally protected, totally enclosed with shaft down design.
- 2 inch filter standard with slide out design.
- 24 volt control system with resettable circuit breakers.
- Colored and labeled wiring.
- Copper tube/Aluminum Fin coils.
- Supplemental electric heat provides 100% efficient heating.

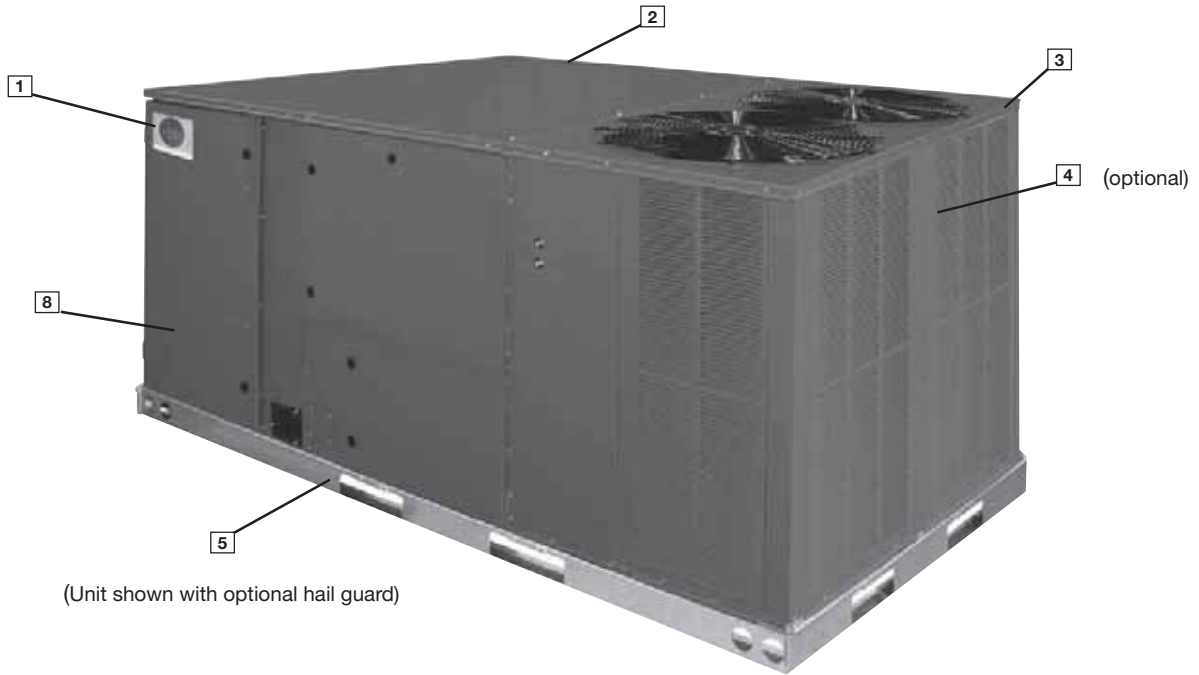

(Unit shown with optional hail guard)

Rheem Package equipment is designed from the ground up with the latest features and benefits required to compete in today's market. The clean design stands alone in the industry and is a testament to the quality, reliability, ease of installation and serviceability that goes into each unit. Outwardly, the large Rheem label (1) identifies the brand to the customer. The sheet-metal cabinet (2) uses nothing less than 18-gauge material for structural components with an underlying coat of G90. To ensure the leak-proof integrity of these units, the design utilizes a one-piece top with a 1/8" drip lip (3), gasket-protected panels and screws. The optional Rheem hail guard (4) is its trademark, and sets the standard for coil protection in the industry. Every Rheem package unit uses the toughest finish in the industry, using electro deposition baked-on enamel tested to withstand a rigorous 1000-hour salt spray test, per ASTM B117.

Anything built to last must start with the right foundation. In this case, the foundation is 14-gauge, commercial-grade, full-perimeter base rails (5), which integrate fork slots and rigging holes to save set-up time on the job site. The base pan is stamped, which forms a 1-1/8" flange around the supply and return cover and has eliminated the worry of water entering the conditioned space (6). The drainpan (7) is made of material that resists the growth of harmful bacteria and is sloped for the latest IAQ benefits. The drainpan slides out for easy cleaning. The insulation has been placed on the underside of the basepan, removing areas that would allow for potential moisture accumulation, which can facilitate growth of harmful bacteria. All insulation is secured with both adhesive and mechanical fasteners, and all edges are hidden.



During development, each unit was tested to U.L. 1995, AHRI 340-370 and other Rheem-required reliability tests. Rheem adheres to stringent ISO 9002 quality procedures, and each unit bears the U.L. and AHRI certification labels located on the unit nameplate (8). Contractors can rest assured that when a Rheem package unit arrives at the job, it is ready to go with a factory charge and quality checks. Each unit also proudly displays the "Made in the USA" designation.

Access to all major compartments is from the front of the unit, including the filter and electrical compartment, blower compartment, heating section, and outdoor section. Each panel is permanently embossed with the compartment name (control/filter access, blower access and furnace access).

Control/filter blower and electric heat compartment access are through large, hinged-access panels secured with 1/4 turn fasteners. On the outside of the panel is the unit nameplate, which contains the model and serial number, electrical data and other important unit information.

The unit charging chart is located on the inside of the electrical and filter compartment door. Electrical wiring diagrams are found on the control box cover, which allows contractors to move them to more readable locations. To the right of the control box the model and serial number can be found. Having this information on the inside will assure model identification for the life of the product. The production line quality test assurance label is also placed in this location (9). The two-inch throwaway filters (10) are easily removed on a tracked system for easy replacement.

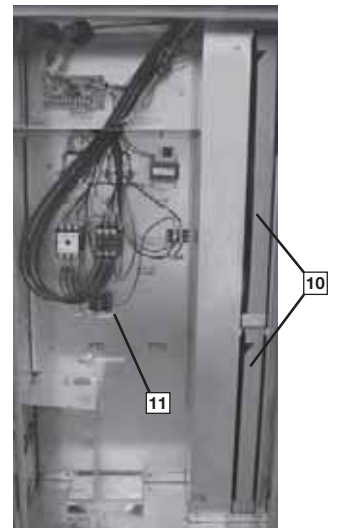



Inside the control box (11), each electrical component is clearly identified with a label that matches the component to the wire diagram for ease of trouble shooting. All wiring is numbered on each end of the termination and color-coded to match the wiring diagram. The control transformer has a low voltage circuit breaker that trips if a low voltage electrical short occurs.

For added convenience in the field, a factory-installed convenience outlet (12) is available. Low and High voltage can enter either from the side or through the base. Low-voltage connections are made through the low-voltage terminal strip on the cooling control board. The high-voltage connection is terminated at the terminal block inside electric heat compartment. The suggested mounting for the field-installed disconnect is on the exterior side of the electrical control box.

The externally mounted gauge ports, which are permanently identified by embossed wording that clearly identifies the high pressure connection and the low pressure connection, extend through the compressor access panel (13). With the gauge ports mounted externally, an accurate diagnostic of system operation can be performed quickly and easily. The blower compartment access door is hinged and secured with 1/4 turn fasteners to allow easy maintenance of the blower assembly, the entire assembly slides out by removing the 3/8" screws from the blower retention bracket. The adjustable motor pulley (14) can easily be



adjusted by loosening the bolts on either side of the motor mount. Removing the bolts allows for easy removal of the blower pulley by pushing the blower assembly up to loosen the belt. Once the pulley is removed, the motor sheave can be adjusted to the desired number of turns, ranging from 0 to 6 turns open. Where the demands for the job require high static, Rheem has high-static drives available that deliver nominal airflow up to 2" of static. By referring to the airflow performance tables listed in the installation instructions, proper static pressure and CFM requirements can be dialed in. The scroll housing (15) and blower scroll provide quiet and efficient airflow. The blower sheave is secured by an "H" bushing which firmly secures the pulley to the blower shaft for years of trouble-free operation. The "H" bushing allows for easy removal of the blower pulley from the shaft, as opposed to the use of a set screw, which can score the shaft, creating burrs that make blower-pulley removal difficult.

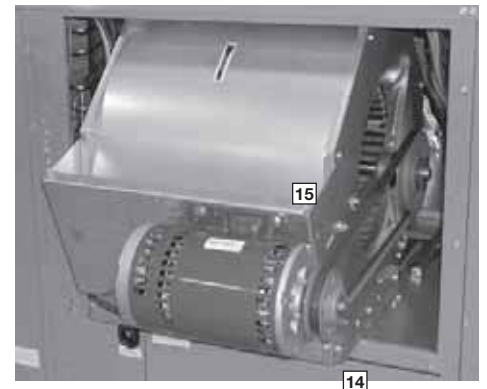

The optional freeze stat refrigerant safety device (16) is attached to the suction line in the blower section. The freeze stat protects the compressor if evaporator coil gets too cold (below freezing) due to low airflow or low evaporator load. The high and low pressure switches (17) and the optional low ambient control are mounted on the gauge port lines inside the compressor access panel. The high pressure switch will shut off the compressor if pressure exceeds 610 PSIG. The low pressure switch is used for loss of charge protection. The low ambient control allows for cooling operation down to 0 degrees ambient by cycling the outdoor fans. Enhanced feature demand defrost control has high and low pressure control inputs with unique pressure switch logic built into the micro-processor to provide compressor and system protection without nuisance lock-outs. LED's on the defrost control provide diagnostic information for service personnel. (18)

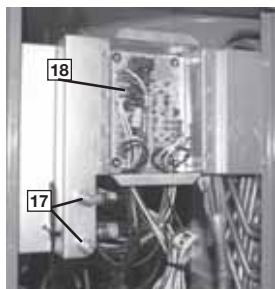

Inside the blower compartment the evaporator can also be viewed. The evaporator uses enhanced fin technology for maximum heat transfer. The thermal expansion valve and venturi distributor assure even distribution of refrigerant throughout the evaporator.



Wiring throughout the unit is neatly bundled and routed. Where wire harnesses go through the condenser bulkhead or blower deck, a molded wire harness assembly (19) provides an air-tight and water-tight seal, and provides strain relief. Care is also taken to tuck raw edges of insulation behind sheet metal to improve indoor air quality.

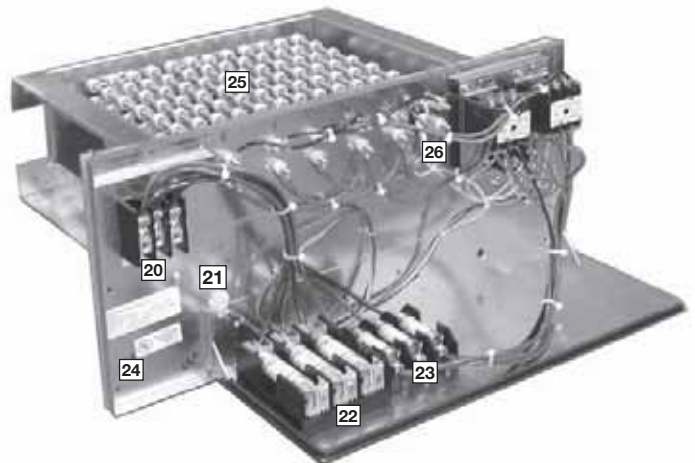

The heating compartment contains the latest electric furnace technology on the market. The 100% efficient electric furnace can be factory-installed or easily field-installed. Built with ease-of-installation in mind, the electric furnace is completely wired for slide-in, plug-and-play installation in the field. With choices of 15 to 40 kilowatt offerings, the contractor is assured to get the correct amount of heating output to meet the designed heating load.

Power hook-up in the field is easy with single-point wiring to a terminal block (20) and a polarized plug for the low-voltage connection (21). The electric furnace comes with fuses for the unit (22) and for the electric furnace (23), and is UL certified (24). The electric heating elements are of a wound-wire construction (25) and isolated with ceramic bushings. The limit switch (26) protects the design from over-temperature conditions. Each electric furnace has the capability to be converted from single-stage operation to two-stage operation by removing a jumper on the low-voltage terminal strip.

The compressor compartment houses the heartbeat of the unit. The scroll compressor (27) is known for its long life, and for reliable, quiet, and efficient operation. The suction and discharge lines (28) are designed to absorb the strain and stress that the starting torque, steady state operation, and shut down cycle imposed on the refrigerant tubing.

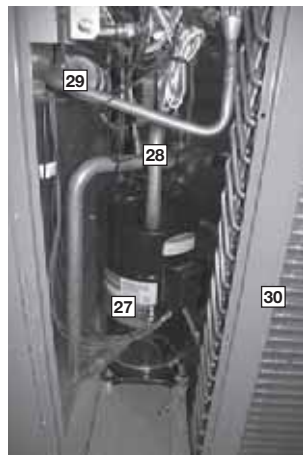

A liquid line bi-flow filter drier (29) is conveniently located near the TXV in the outdoor section. The condenser fan motors (29) can easily be accessed and maintained through the unit top. The polarized plug connection allows the motor to be changed quickly and eliminates the need to snake wires through the unit.

The outdoor coil uses the latest enhanced fin design (30) for the most effective method of heat transfer. Optional louvered panels offer hail protection to outdoor coils without obstructing airflow.

Each unit is designed for both downflow or horizontal applications (31) for job configuration flexibility. The return air compartment can also contain an economizer (32).



Two economizer models exist, one for downflow applications, and one for horizontal applications. Each unit is pre-wired for the economizer to allow quick plug-in installation. The economizer is also available as a factory-installed option. The economizer, which provides free cooling when outdoor conditions are suitable and also provides fresh air to meet local requirements, comes standard with single enthalpy controls. The controls can be upgraded to dual enthalpy easily in the field. The direct drive actuator combined with gear drive dampers has eliminated the need for linkage adjustment in the field. The economizer control has a minimum position setpoint, an outdoor-air setpoint, a mix-air setpoint, and a CO² setpoint. Barometric relief is standard on all economizers. Power Exhaust (33) is easily field-installed. The power exhaust is housed in the barometric relief opening and is easily slipped in with a plug-in assembly.



The Rheem roofcurb (34) is made for toolless assembly at the jobsite by sequentially engaging the corner brackets into the adjacent curb sides (35), which makes the assembly process quick and easy.



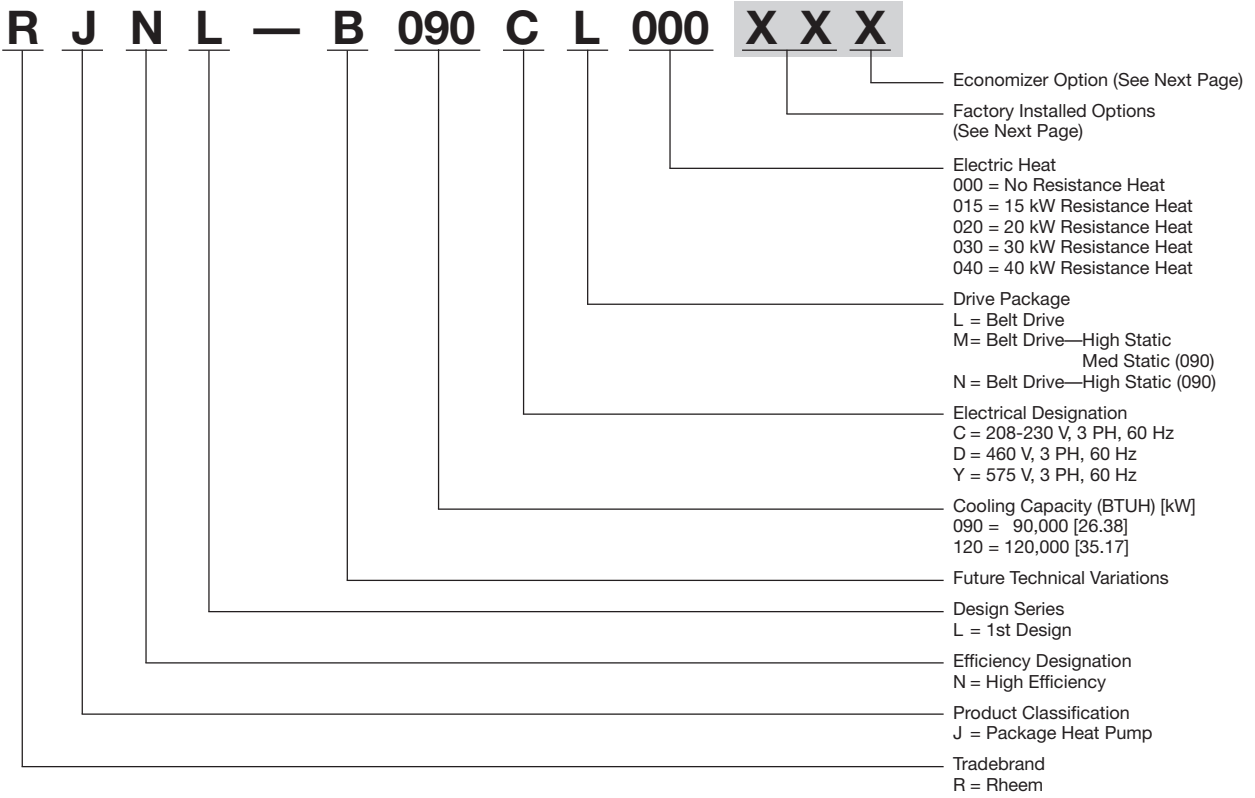

[] Designates Metric Conversions



FACTORY INSTALLED OPTION CODES FOR RJNL (7.5 & 10 TON) [26.4 & 35.2 kW]

Option Code	Hail Guard	Non-Powered Convenience Outlet	Low Ambient/Freeze Stat
AA	No Options	No Options	No Options
AD	x		
AG		x	
AP			x
BY	x		x
BJ	x	x	
CX	x	x	x
JC		x	x

ECONOMIZER SELECTION FOR RJNL (7.5 & 10 TON) [26.4 & 35.2 kW]

	No Economizer	Single Enthalpy Economizer With Barometric Relief	Single Enthalpy Economizer With Barometric Relief And Smoke Detector
A	x		
F		x	
G			x

"x" indicates factory installed option.

Instructions for Factory Installed Option(s) Selection

Note: Three characters following the model number will be utilized to designate a factory-installed option or combination of options. If no factory option(s) is required, nothing follows the model number.

Step 1. After a basic rooftop model is selected, choose a *two-character* option code from the FACTORY INSTALLED OPTION SELECTION TABLE.

Proceed to Step 2.

Step 2. The last option code character is utilized for factory-installed economizers. Choose a character from the FACTORY INSTALLED ECONOMIZER SELECTION TABLE.

Examples:

RJNL-BA090CL000**XXX**(where **XX** is factory installed option)

RJNL-BA090CL000.....No options

RJNL-BA090CL000**AAF**No option with factory installed economizer

RJNL-BA090CL000**ADA**Hailguard with no factory installed economizer

RJNL-BA090CL000**ADF**Options same as above with factory installed economizer

[] Designates Metric Conversions



SELECTION PROCEDURE

To select an RJNL-B Heat Pump unit to meet a job requirement, follow this procedure, with example, using data supplied in this specification sheet.

1. DETERMINE COOLING AND HEATING REQUIREMENTS AND SPECIFIC OPERATING CONDITIONS FROM PLANS AND SPECS.

Example:

Voltage—	230 V – 3 Phase – 60 Hz
Total cooling capacity—	106,000 BTUH [31.0 kW]
Sensible cooling capacity—	82,000 BTUH [24.0 kW]
Heating capacity—	130,000 BTUH [38.1 kW]
*Condenser Entering Air—	95°F [35°C] DB
*Evaporator Mixed Air Entering—	65°F [18.3°C] WB; 78°F [25.6°C] DB
*Indoor Air Flow (vertical)—	3600 CFM [1699 L/s]
*External Static Pressure—	.40 in. WG [.10 kPa]

2. SELECT UNIT TO MEET COOLING REQUIREMENTS.

Since total cooling is within the range of a nominal 10 ton [35.1 kW] unit, enter cooling performance table at 95°F [35.0°C] DB condenser inlet air. Interpolate between 63°F [17.2 °C] and 67°F [19.4°C] WB to determine total and sensible capacity and power input for 65°F [18.3 °C] WB evaporator inlet air at 4000 CFM [1888 L/s] indoor air flow (table basis):

Total Cooling Capacity =	121,950 BTUH [35.71 kW]
Sensible Cooling Capacity =	102,750 BTUH [30.09 kW]
Power Input (Compressor and Cond. Fans) =	9,400 watts

Use formula in note ① to determine sensible capacity at 78°F [25.6 °C] DB evaporator entering air:

$$102,750 + (1.10 \times 3,600 \times (1 - 0.05) \times (78 - 80))$$

$$\text{Sensible Cooling Capacity} = 95,226 \text{ BTUH [27.88 kW]}$$

3. CORRECT CAPACITIES OF STEP 2 FOR ACTUAL AIR FLOW.

Select factors from airflow correction table at 3600 CFM [1699 L/s] and apply to data obtained in step 2 to obtain gross capacity:

Total Capacity, $121,950 \times .99 =$	120,731 BTUH [35.35 kW]
Sensible Capacity = $95,226 \times 0.97 =$	92,369 BTUH [27.05 kW]
Power Input $9,400 \times .99 =$	9,306 Watts

These are Gross Capacities, not corrected for blower motor heat or power.

4. DETERMINE BLOWER SPEED AND WATTS TO MEET SYSTEM DESIGN.

Enter Indoor Blower performance table at 3600 CFM [1699 L/s]. Total ESP (external static pressure) per the spec of 0.40 in. WG [.10 kPa] includes the system duct and grilles. Add from the table "Component Air Resistance", 0.08 in. WG [.02 kPa] for wet coil, 0 in. WG [.00 kPa] for downflow air flow, for a total selection static pressure of 0.48 (0.5) in. WG [.12 kPa], and determine:

RPM =	755
WATTS =	1,488
DRIVE =	L (standard 2 H.P. motor)

5. CALCULATE INDOOR BLOWER BTUH HEAT EFFECT FROM MOTOR WATTS, STEP 4.

$$1,488 \times 3.412 = 5,077 \text{ BTUH [1.49 kW]}$$

6. CALCULATE NET COOLING CAPACITIES, EQUAL TO GROSS CAPACITY, STEP 3, MINUS INDOOR BLOWER MOTOR HEAT.

$$\text{Net Total Capacity} = 120,731 - 5,077 =$$

$$115,654 \text{ BTUH [33.86 kW]}$$

$$\text{Net Sensible Capacity} = 92,369 - 5,077 =$$

$$87,292 \text{ BTUH [25.56 kW]}$$

7. CALCULATE UNIT INPUT AND JOB EER.

$$\text{Total Power Input} = 9,306 \text{ (step 3)} + 1,488$$

$$\text{(step 4)} = 10,794 \text{ Watts}$$

$$\text{EER} = \frac{\text{Net Total BTUH [kW] (step 6)}}{\text{Power Input, Watts (above)}} = \frac{115,654}{10,794} = 10.71$$

8. SELECT UNIT HEATING CAPACITY.

From Heater Kit Table select kW to meet heating capacity requirement; multiply kW x 3412 to convert to BTUH

Use 40 kW Heater Kit
Heater Kit Model: RXJJ-CC40C
Heater Kit Capacity: 131,021 BTUH [38.4 kW]

Add indoor blower heat effect (step 5) to Heater Kit Capacity to get total heating capacity:

$$131,021 + 5,077 = 136,098 \text{ BTUH [39.9 kW]}$$

9. CHOOSE MODEL RJNL-B120CL040

*NOTE: These operating conditions are typical of a commercial application in a 95°F/79°F [35°C/26°C] design area with indoor design of 76°F [24°C] DB and 50% RH and 10% ventilation air, with the unit roof mounted and centered on the zone it conditions by ducts.

[] Designates Metric Conversions



NOMINAL SIZES 7.5 & 10 TONS [26.4 & 35.2 kW]

Model RJNL- Series	B090CL	B090CM	B090CN	B090DL
Cooling Performance¹				CONTINUED →
Gross Cooling Capacity Btu [kW]	98,000 [28.71]	98,000 [28.71]	98,000 [28.71]	98,000 [28.71]
EER/SEER ²	11/NA	11/NA	11/NA	11/NA
Nominal CFM/AHRI Rated CFM [L/s]	3000/2925 [1416/1380]	3000/2925 [1416/1380]	3000/2925 [1416/1380]	3000/2925 [1416/1380]
AHRI Net Cooling Capacity Btu [kW]	94,000 [27.54]	94,000 [27.54]	94,000 [27.54]	94,000 [27.54]
Net Sensible Capacity Btu [kW]	70,800 [20.74]	70,800 [20.74]	70,800 [20.74]	70,800 [20.74]
Net Latent Capacity Btu [kW]	23,200 [6.8]	23,200 [6.8]	23,200 [6.8]	23,200 [6.8]
Integrated Part Load Value ³	N/A	N/A	N/A	N/A
Net System Power kW	8.54	8.54	8.54	8.54
Heating Performance (Heat Pumps)				
Heating Input Btu [kW] Rating	87,000 [25.49]	87,000 [25.49]	87,000 [25.49]	87,000 [25.49]
System Power KW/COP	7.5/3.4	7.5/3.4	7.5/3.4	7.5/3.4
Low Temp. Btuh [kW] Rating	52,000 [15.24]	52,000 [15.24]	52,000 [15.24]	52,000 [15.24]
System Power KW/COP	6.62/2.3	6.62/2.3	6.62/2.3	6.62/2.3
Compressor				
No./Type	1/Scroll	1/Scroll	1/Scroll	1/Scroll
Outdoor Sound Rating (dB)⁴	88	88	88	88
Outdoor Coil—Fin Type	Louvered	Louvered	Louvered	Louvered
Tube Type	Rifled	Rifled	Rifled	Rifled
Tube Size in. [mm] OD	0.375 [9.5]	0.375 [9.5]	0.375 [9.5]	0.375 [9.5]
Face Area sq. ft. [sq. m]	24.88 [2.31]	24.88 [2.31]	24.88 [2.31]	24.88 [2.31]
Rows / FPI [FPcm]	2 / 22 [9]	2 / 22 [9]	2 / 22 [9]	2 / 22 [9]
Refrigerant Control	TX Valves	TX Valves	TX Valves	TX Valves
Indoor Coil—Fin Type	Louvered	Louvered	Louvered	Louvered
Tube Type	Rifled	Rifled	Rifled	Rifled
Tube Size in. [mm]	0.375 [9.5]	0.375 [9.5]	0.375 [9.5]	0.375 [9.5]
Face Area sq. ft. [sq. m]	13.5 [1.25]	13.5 [1.25]	13.5 [1.25]	13.5 [1.25]
Rows / FPI [FPcm]	3 / 18 [7]	3 / 18 [7]	3 / 18 [7]	3 / 18 [7]
Refrigerant Control	TX Valves	TX Valves	TX Valves	TX Valves
Drain Connection No./Size in. [mm]	1/1 [25.4]	1/1 [25.4]	1/1 [25.4]	1/1 [25.4]
Outdoor Fan—Type	Propeller	Propeller	Propeller	Propeller
No. Used/Diameter in. [mm]	2/24 [609.6]	2/24 [609.6]	2/24 [609.6]	2/24 [609.6]
Drive Type/No. Speeds	Direct/1	Direct/1	Direct/1	Direct/1
CFM [L/s]	8000 [3775]	8000 [3775]	8000 [3775]	8000 [3775]
No. Motors/HP	2 at 1/3 HP	2 at 1/3 HP	2 at 1/3 HP	2 at 1/3 HP
Motor RPM	1075	1075	1075	1075
Indoor Fan—Type	FC Centrifugal	FC Centrifugal	FC Centrifugal	FC Centrifugal
No. Used/Diameter in. [mm]	1/15x15 [381x381]	1/15x15 [381x381]	1/15x15 [381x381]	1/15x15 [381x381]
Drive Type/No. Speeds	Belt/Variable	Belt/Variable	Belt/Variable	Belt/Variable
No. Motors	1	1	1	1
Motor HP	2	2	3	2
Motor RPM	1725	1725	1725	1725
Motor Frame Size	56	56	56	56
Filter—Type	Disposable	Disposable	Disposable	Disposable
Furnished	Yes	Yes	Yes	Yes
(No.) Size Recommended in. [mm]	(6)2x18x18 [51x457x457]	(6)2x18x18 [51x457x457]	(6)2x18x18 [51x457x457]	(6)2x18x18 [51x457x457]
Refrigerant Charge Oz. (Sys. 1/Sys. 2) [g]	350 [9922]	350 [9922]	350 [9922]	350 [9922]
Weights				
Net Weight lbs. [kg]	1009 [458]	1009 [458]	1017 [461]	1009 [458]
Ship Weight lbs. [kg]	1089 [494]	1089 [494]	1097 [498]	1089 [494]

See Page 15 for Notes.

[] Designates Metric Conversions



NOMINAL SIZES 7.5 & 10 TONS [26.4 & 35.2 kW]

Model RJNL- Series	B090DM	B090DN	B090YL	B090YM
Cooling Performance¹				CONTINUED →
Gross Cooling Capacity Btu [kW]	98,000 [28.71]	98,000 [28.71]	98,000 [28.71]	98,000 [28.71]
EER/SEER ²	11/NA	11/NA	11/NA	11/NA
Nominal CFM/AHRI Rated CFM [L/s]	3000/2925 [1416/1380]	3000/2925 [1416/1380]	3000/2925 [1416/1380]	3000/2925 [1416/1380]
AHRI Net Cooling Capacity Btu [kW]	94,000 [27.54]	94,000 [27.54]	94,000 [27.54]	94,000 [27.54]
Net Sensible Capacity Btu [kW]	70,800 [20.74]	70,800 [20.74]	70,800 [20.74]	70,800 [20.74]
Net Latent Capacity Btu [kW]	23,200 [6.8]	23,200 [6.8]	23,200 [6.8]	23,200 [6.8]
Integrated Part Load Value ³	N/A	N/A	N/A	N/A
Net System Power kW	8.54	8.54	8.54	8.54
Heating Performance (Heat Pumps)				
Heating Input Btu [kW] Rating	87,000 [25.49]	87,000 [25.49]	87,000 [25.49]	87,000 [25.49]
System Power KW/COP	7.5/3.4	7.5/3.4	7.5/3.4	7.5/3.4
Low Temp. Btuh [kW] Rating	52,000 [15.24]	52,000 [15.24]	52,000 [15.24]	52,000 [15.24]
System Power KW/COP	6.62/2.3	6.62/2.3	6.62/2.3	6.62/2.3
Compressor				
No./Type	1/Scroll	1/Scroll	1/Scroll	1/Scroll
Outdoor Sound Rating (dB)⁴	88	88	88	88
Outdoor Coil—Fin Type	Louvered	Louvered	Louvered	Louvered
Tube Type	Rifled	Rifled	Rifled	Rifled
Tube Size in. [mm] OD	0.375 [9.5]	0.375 [9.5]	0.375 [9.5]	0.375 [9.5]
Face Area sq. ft. [sq. m]	24.88 [2.31]	24.88 [2.31]	24.88 [2.31]	24.88 [2.31]
Rows / FPI [FPcm]	2 / 22 [9]	2 / 22 [9]	2 / 22 [9]	2 / 22 [9]
Refrigerant Control	TX Valves	TX Valves	TX Valves	TX Valves
Indoor Coil—Fin Type	Louvered	Louvered	Louvered	Louvered
Tube Type	Rifled	Rifled	Rifled	Rifled
Tube Size in. [mm]	0.375 [9.5]	0.375 [9.5]	0.375 [9.5]	0.375 [9.5]
Face Area sq. ft. [sq. m]	13.5 [1.25]	13.5 [1.25]	13.5 [1.25]	13.5 [1.25]
Rows / FPI [FPcm]	3 / 18 [7]	3 / 18 [7]	3 / 18 [7]	3 / 18 [7]
Refrigerant Control	TX Valves	TX Valves	TX Valves	TX Valves
Drain Connection No./Size in. [mm]	1/1 [25.4]	1/1 [25.4]	1/1 [25.4]	1/1 [25.4]
Outdoor Fan—Type	Propeller	Propeller	Propeller	Propeller
No. Used/Diameter in. [mm]	2/24 [609.6]	2/24 [609.6]	2/24 [609.6]	2/24 [609.6]
Drive Type/No. Speeds	Direct/1	Direct/1	Direct/1	Direct/1
CFM [L/s]	8000 [3775]	8000 [3775]	8000 [3775]	8000 [3775]
No. Motors/HP	2 at 1/3 HP	2 at 1/3 HP	2 at 1/3 HP	2 at 1/3 HP
Motor RPM	1075	1075	1075	1075
Indoor Fan—Type	FC Centrifugal	FC Centrifugal	FC Centrifugal	FC Centrifugal
No. Used/Diameter in. [mm]	1/15x15 [381x381]	1/15x15 [381x381]	1/15x15 [381x381]	1/15x15 [381x381]
Drive Type/No. Speeds	Belt/Variable	Belt/Variable	Belt/Variable	Belt/Variable
No. Motors	1	1	1	1
Motor HP	2	3	2	2
Motor RPM	1725	1725	1725	1725
Motor Frame Size	56	56	56	56
Filter—Type	Disposable	Disposable	Disposable	Disposable
Furnished	Yes	Yes	Yes	Yes
(No.) Size Recommended in. [mm]	(6)2x18x18 [51x457x457]	(6)2x18x18 [51x457x457]	(6)2x18x18 [51x457x457]	(6)2x18x18 [51x457x457]
Refrigerant Charge Oz. (Sys. 1/Sys. 2) [g]	350 [9922]	350 [9922]	350 [9922]	350 [9922]
Weights				
Net Weight lbs. [kg]	1009 [458]	1017 [461]	1009 [458]	1009 [458]
Ship Weight lbs. [kg]	1089 [494]	1097 [498]	1089 [494]	1089 [494]

See Page 15 for Notes.

[] Designates Metric Conversions

NOMINAL SIZES 7.5 & 10 TONS [26.4 & 35.2 kW]

Model RJNL- Series	B090YN	B120CL	B120CM	B120DL
Cooling Performance¹				CONTINUED →
Gross Cooling Capacity Btu [kW]	98,000 [28.71]	125,000 [36.62]	125,000 [36.62]	125,000 [36.62]
EER/SEER ²	11/NA	11/NA	11/NA	11/NA
Nominal CFM/AHRI Rated CFM [L/s]	3000/2925 [1416/1380]	4000/4000 [1888/1888]	4000/4000 [1888/1888]	4000/4000 [1888/1888]
AHRI Net Cooling Capacity Btu [kW]	94,000 [27.54]	120,000 [35.16]	120,000 [35.16]	120,000 [35.16]
Net Sensible Capacity Btu [kW]	70,800 [20.74]	91,600 [26.84]	91,600 [26.84]	91,600 [26.84]
Net Latent Capacity Btu [kW]	23,200 [6.8]	28,400 [8.32]	28,400 [8.32]	28,400 [8.32]
Integrated Part Load Value ³	N/A	N/A	N/A	N/A
Net System Power kW	8.54	10.91	10.91	10.91
Heating Performance (Heat Pumps)				
Heating Input Btu [kW] Rating	87,000 [25.49]	109,000 [31.94]	109,000 [31.94]	109,000 [31.94]
System Power KW/COP	7.5/3.4	9.39/3.4	9.39/3.4	9.39/3.4
Low Temp. Btuh [kW] Rating	52,000 [15.24]	69,000 [20.22]	69,000 [20.22]	69,000 [20.22]
System Power KW/COP	6.62/2.3	8.79/2.3	8.79/2.3	8.79/2.3
Compressor				
No./Type	1/Scroll	1/Scroll	1/Scroll	1/Scroll
Outdoor Sound Rating (dB)⁴	88	88	88	88
Outdoor Coil—Fin Type	Louvered	Louvered	Louvered	Louvered
Tube Type	Rifled	Rifled	Rifled	Rifled
Tube Size in. [mm] OD	0.375 [9.5]	0.375 [9.5]	0.375 [9.5]	0.375 [9.5]
Face Area sq. ft. [sq. m]	24.88 [2.31]	28.8 [2.68]	28.8 [2.68]	28.8 [2.68]
Rows / FPI [FPcm]	2 / 22 [9]	2 / 22 [9]	2 / 22 [9]	2 / 22 [9]
Refrigerant Control	TX Valves	TX Valves	TX Valves	TX Valves
Indoor Coil—Fin Type	Louvered	Louvered	Louvered	Louvered
Tube Type	Rifled	Rifled	Rifled	Rifled
Tube Size in. [mm]	0.375 [9.5]	0.375 [9.5]	0.375 [9.5]	0.375 [9.5]
Face Area sq. ft. [sq. m]	13.5 [1.25]	15.75 [1.46]	15.75 [1.46]	15.75 [1.46]
Rows / FPI [FPcm]	3 / 18 [7]	4 / 15 [6]	4 / 15 [6]	4 / 15 [6]
Refrigerant Control	TX Valves	TX Valves	TX Valves	TX Valves
Drain Connection No./Size in. [mm]	1/1 [25.4]	1/1 [25.4]	1/1 [25.4]	1/1 [25.4]
Outdoor Fan—Type	Propeller	Propeller	Propeller	Propeller
No. Used/Diameter in. [mm]	2/24 [609.6]	2/24 [609.6]	2/24 [609.6]	2/24 [609.6]
Drive Type/No. Speeds	Direct/1	Direct/1	Direct/1	Direct/1
CFM [L/s]	8000 [3775]	8000 [3775]	8000 [3775]	8000 [3775]
No. Motors/HP	2 at 1/3 HP	2 at 1/2 HP	2 at 1/2 HP	2 at 1/2 HP
Motor RPM	1075	1075	1075	1075
Indoor Fan—Type	FC Centrifugal	FC Centrifugal	FC Centrifugal	FC Centrifugal
No. Used/Diameter in. [mm]	1/15x15 [381x381]	1/15x15 [381x381]	1/15x15 [381x381]	1/15x15 [381x381]
Drive Type/No. Speeds	Belt/Variable	Belt/Variable	Belt/Variable	Belt/Variable
No. Motors	1	1	1	1
Motor HP	3	2	3	2
Motor RPM	1725	1725	1725	1725
Motor Frame Size	56	56	56	56
Filter—Type	Disposable	Disposable	Disposable	Disposable
Furnished	Yes	Yes	Yes	Yes
(No.) Size Recommended in. [mm]	(6)2x18x18 [51x457x457]	(3)2x18x18 [51x457x457] (3)2x18x24 [51x457x610]	(3)2x18x18 [51x457x457] (3)2x18x24 [51x457x610]	(3)2x18x18 [51x457x457] (3)2x18x24 [51x457x610]
Refrigerant Charge Oz. (Sys. 1/Sys. 2) [g]	350 [9922]	496 [14062]	496 [14062]	496 [14062]
Weights				
Net Weight lbs. [kg]	1017 [461]	1185 [538]	1193 [541]	1185 [538]
Ship Weight lbs. [kg]	1097 [498]	1265 [574]	1273 [577]	1265 [574]

See Page 15 for Notes.

[] Designates Metric Conversions



NOMINAL SIZES 7.5 & 10 TONS [26.4 & 35.2 kW]

Model RJNL- Series	B120DM	B120YL	B120YM
Cooling Performance¹			
Gross Cooling Capacity Btu [kW]	125,000 [36.62]	125,000 [36.62]	125,000 [36.62]
EER/SEER ²	11/NA	11/NA	11/NA
Nominal CFM/AHRI Rated CFM [L/s]	4000/4000 [1888/1888]	4000/4000 [1888/1888]	4000/4000 [1888/1888]
AHRI Net Cooling Capacity Btu [kW]	120,000 [35.16]	120,000 [35.16]	120,000 [35.16]
Net Sensible Capacity Btu [kW]	91,600 [26.84]	91,600 [26.84]	91,600 [26.84]
Net Latent Capacity Btu [kW]	28,400 [8.32]	28,400 [8.32]	28,400 [8.32]
Integrated Part Load Value ³	N/A	N/A	N/A
Net System Power kW	10.91	10.91	10.91
Heating Performance (Heat Pumps)			
Heating Input Btu [kW] Rating	109,000 [31.94]	109,000 [31.94]	109,000 [31.94]
System Power KW/COP	9.39/3.4	9.39/3.4	9.39/3.4
Low Temp. Btuh [kW] Rating	69,000 [20.22]	69,000 [20.22]	69,000 [20.22]
System Power KW/COP	8.79/2.3	8.79/2.3	8.79/2.3
Compressor			
No./Type	1/Scroll	1/Scroll	1/Scroll
Outdoor Sound Rating (dB)⁴			
	88	88	88
Outdoor Coil—Fin Type			
Tube Type	Louvered	Louvered	Louvered
Tube Size in. [mm] OD	Rifled	Rifled	Rifled
Face Area sq. ft. [sq. m]	0.375 [9.5]	0.375 [9.5]	0.375 [9.5]
Rows / FPI [FPcm]	28.8 [2.68]	28.8 [2.68]	28.8 [2.68]
Refrigerant Control	2 / 22 [9]	2 / 22 [9]	2 / 22 [9]
	TX Valves	TX Valves	TX Valves
Indoor Coil—Fin Type			
Tube Type	Louvered	Louvered	Louvered
Tube Size in. [mm]	Rifled	Rifled	Rifled
Face Area sq. ft. [sq. m]	0.375 [9.5]	0.375 [9.5]	0.375 [9.5]
Rows / FPI [FPcm]	15.75 [1.46]	15.75 [1.46]	15.75 [1.46]
Refrigerant Control	4 / 15 [6]	4 / 15 [6]	4 / 15 [6]
Drain Connection No./Size in. [mm]	TX Valves	TX Valves	TX Valves
	1/1 [25.4]	1/1 [25.4]	1/1 [25.4]
Outdoor Fan—Type			
No. Used/Diameter in. [mm]	Propeller	Propeller	Propeller
Drive Type/No. Speeds	2/24 [609.6]	2/24 [609.6]	2/24 [609.6]
CFM [L/s]	Direct/1	Direct/1	Direct/1
No. Motors/HP	8000 [3775]	8000 [3775]	8000 [3775]
Motor RPM	2 at 1/2 HP	2 at 1/2 HP	2 at 1/2 HP
	1075	1075	1075
Indoor Fan—Type			
No. Used/Diameter in. [mm]	FC Centrifugal	FC Centrifugal	FC Centrifugal
Drive Type/No. Speeds	1/15x15 [381x381]	1/15x15 [381x381]	1/15x15 [381x381]
No. Motors	Belt/Variable	Belt/Variable	Belt/Variable
Motor HP	1	1	1
Motor RPM	3	2	3
Motor Frame Size	1725	1725	1725
	56	56	56
Filter—Type			
Furnished	Disposable	Disposable	Disposable
(No.) Size Recommended in. [mm]	Yes	Yes	Yes
	(3)2x18x18 [51x457x457]	(3)2x18x18 [51x457x457]	(3)2x18x18 [51x457x457]
	(3)2x18x24 [51x457x610]	(3)2x18x24 [51x457x610]	(3)2x18x24 [51x457x610]
Refrigerant Charge Oz. (Sys. 1/Sys. 2) [g]			
	496 [14062]	496 [14062]	496 [14062]
Weights			
Net Weight lbs. [kg]	1193 [541]	1185 [538]	1193 [541]
Ship Weight lbs. [kg]	1273 [577]	1265 [574]	1273 [577]

See Page 15 for Notes.

[] Designates Metric Conversions

NOTES:

1. Cooling Performance is rated at 95° F ambient, 80° F entering dry bulb, 67° F entering wet bulb. Gross capacity does not include the effect of fan motor heat. AHRI capacity is net and includes the effect of fan motor heat. Units are suitable for operation to $\pm 20\%$ of nominal cfm. Units are certified in accordance with the Unitary Air Conditioner Equipment certification program, which is based on AHRI Standard 210/240 or 360.
2. EER and/or SEER are rated at AHRI conditions and in accordance with DOE test procedures.
3. Integrated Part Load Value is rated in accordance with AHRI Standard 210/240 or 360. Units are rated at 80° F ambient, 80° F entering dry bulb, and 67° F entering wet bulb at AHRI rated cfm.
4. Outdoor Sound Rating shown is tested in accordance with AHRI Standard 270.



COOLING PERFORMANCE DATA—B090

		ENTERING INDOOR AIR @ 80°F [26.7°C] dbE ①									
		71°F [21.7°C]			67°F [19.4°C]			63°F [17.2°C]			
		3840 [1812]	2925 [1380]	2560 [1208]	3840 [1812]	2925 [1380]	2560 [1208]	3840 [1812]	2925 [1380]	2560 [1208]	
		CFM [L/s]									
		DR ①	.0	.02	.05	.0	.02	.05	.0	.02	.05
OUTDOOR DRY BULB TEMPERATURE °F [°C]	75 [23.9]	Total BTUH [kW]	120.0 [35.2]	113.6 [33.3]	111.0 [32.5]	114.9 [33.7]	108.7 [31.9]	106.2 [31.1]	110.7 [32.4]	104.8 [30.7]	102.4 [30.0]
		Sens BTUH [kW]	95.7 [28.1]	77.1 [22.6]	70.2 [20.6]	111.0 [32.5]	90.7 [26.6]	83.1 [24.4]	110.7 [32.5]	100.6 [29.5]	92.5 [27.1]
		Power	6.4	6.2	6.2	6.3	6.1	6.0	6.1	6.0	5.9
	80 [26.7]	Total BTUH [kW]	117.6 [34.5]	111.2 [32.6]	108.7 [31.9]	112.4 [32.9]	106.4 [31.2]	104.0 [30.5]	108.3 [31.7]	102.4 [30.0]	100.1 [29.3]
		Sens BTUH [kW]	90.2 [26.4]	72.3 [21.2]	65.7 [19.3]	105.4 [30.9]	86.0 [25.2]	78.7 [23.1]	108.3 [31.7]	95.8 [28.1]	88.1 [25.8]
		Power	6.7	6.5	6.5	6.6	6.4	6.3	6.4	6.3	6.2
	85 [29.4]	Total BTUH [kW]	114.8 [33.6]	108.6 [31.8]	106.1 [31.1]	109.6 [32.1]	103.7 [30.4]	101.4 [29.7]	105.5 [30.9]	99.8 [29.2]	97.5 [28.6]
		Sens BTUH [kW]	85.0 [24.9]	68.0 [19.9]	61.7 [18.1]	100.3 [29.4]	81.6 [23.9]	74.7 [21.9]	105.5 [30.9]	91.5 [26.8]	84.0 [24.6]
		Power	7.1	6.9	6.8	6.9	6.7	6.6	6.8	6.6	6.5
	90 [32.2]	Total BTUH [kW]	111.7 [32.7]	105.7 [31.0]	103.3 [30.3]	106.6 [31.2]	100.8 [29.5]	98.5 [28.9]	102.4 [30.0]	96.9 [28.4]	94.7 [27.8]
Sens BTUH [kW]		80.4 [23.6]	64.2 [18.8]	58.2 [17.1]	95.8 [28.1]	77.8 [22.8]	71.1 [20.8]	102.4 [30.0]	87.7 [25.7]	80.5 [23.6]	
Power		7.4	7.2	7.1	7.3	7.1	7.0	7.1	6.9	6.9	
95 [35]	Total BTUH [kW]	108.3 [31.7]	102.5 [30.0]	100.2 [29.4]	103.2 [30.2]	97.6 [28.6]	95.4 [28.0]	99.0 [29.0]	93.7 [27.5]	91.6 [26.8]	
	Sens BTUH [kW]	76.3 [22.4]	60.8 [17.8]	55.1 [16.2]	91.7 [26.9]	74.4 [21.8]	68.0 [19.9]	99.0 [29.0]	84.3 [24.7]	77.4 [22.7]	
	Power	7.8	7.6	7.5	7.7	7.5	7.4	7.5	7.3	7.3	
100 [37.8]	Total BTUH [kW]	104.7 [30.7]	99.0 [29.0]	96.8 [28.4]	99.5 [29.2]	94.2 [27.6]	92.0 [27.0]	95.4 [28.0]	90.2 [26.4]	88.2 [25.8]	
	Sens BTUH [kW]	72.9 [21.4]	57.9 [17.0]	52.5 [15.4]	88.1 [25.8]	71.6 [21.0]	65.4 [19.2]	95.4 [28.0]	81.4 [23.9]	74.8 [21.9]	
	Power	8.3	8.0	7.9	8.1	7.9	7.8	8.0	7.8	7.7	
105 [40.6]	Total BTUH [kW]	100.7 [29.5]	95.3 [27.9]	93.1 [27.3]	95.6 [28.0]	90.4 [26.5]	88.4 [25.9]	91.4 [26.8]	86.5 [25.4]	84.5 [24.8]	
	Sens BTUH [kW]	69.9 [20.5]	55.6 [16.3]	50.3 [14.8]	85.3 [25.0]	69.2 [20.3]	63.3 [18.6]	91.4 [26.8]	79.1 [23.2]	72.6 [21.3]	
	Power	8.7	8.5	8.4	8.6	8.3	8.3	8.4	8.2	8.1	
110 [43.3]	Total BTUH [kW]	96.4 [28.3]	91.2 [26.7]	89.2 [26.1]	91.3 [26.8]	86.4 [25.3]	84.4 [24.7]	87.1 [25.5]	82.4 [24.1]	80.6 [23.6]	
	Sens BTUH [kW]	67.4 [19.8]	53.6 [15.7]	48.6 [14.3]	82.7 [24.2]	67.3 [19.7]	61.5 [18.0]	87.1 [25.5]	77.2 [22.6]	71.0 [20.8]	
	Power	9.2	9.0	8.9	9.1	8.8	8.7	8.9	8.7	8.6	
115 [46.1]	Total BTUH [kW]	91.8 [26.9]	86.9 [25.5]	84.9 [24.9]	86.7 [25.4]	82.0 [24.0]	80.2 [23.5]	82.5 [24.2]	78.1 [22.9]	76.3 [22.4]	
	Sens BTUH [kW]	65.6 [19.2]	52.3 [15.3]	47.4 [13.9]	80.8 [23.7]	65.8 [19.3]	60.3 [17.7]	82.5 [24.2]	75.8 [22.2]	69.7 [20.4]	
	Power	9.7	9.5	9.4	9.6	9.3	9.2	9.4	9.2	9.1	

DR —Depression ratio
dbE —Entering air dry bulb
wbE—Entering air wet bulb

Total —Total capacity x 1000 BTUH
Sens —Sensible capacity x 1000 BTUH
Power—KW input

NOTES:

① When the entering air dry bulb is other than 80°F [27°C], adjust the sensible capacity from the table by adding [1.10 x CFM x (1 - DR) x (dbE - 80)].

HEATING PERFORMANCE DATA—B090

		IDB	60°F [15.5°C]			70°F [21.1°C]			80°F [26.7°C]		
		CFM [L/s]	3840 [1812]	2925 [1380]	2560 [1208]	3840 [1812]	2925 [1380]	2560 [1208]	3840 [1812]	2925 [1380]	2560 [1208]
OUTDOOR DRY BULB TEMPERATURE °F [°C]	0 [-17.8]	Total BTUH [kW]	33.5 [9.82]	32.8 [9.61]	32.5 [9.52]	30.1 [8.82]	29.4 [8.62]	29.2 [8.56]	26.7 [7.82]	26.1 [7.65]	25.8 [7.56]
		Power	9.6	10.0	10.1	9.6	10.0	10.1	9.6	10.0	10.1
	5 [26.7]	Total BTUH [kW]	39.4 [11.55]	38.5 [11.28]	38.2 [11.20]	36.0 [10.55]	35.2 [10.32]	34.9 [10.23]	32.5 [9.52]	31.8 [9.32]	31.5 [9.23]
		Power	9.2	9.6	9.7	9.2	9.6	9.7	9.2	9.6	9.7
	10 [-12.2]	Total BTUH [kW]	45.3 [13.28]	44.3 [12.98]	43.9 [12.87]	41.8 [12.25]	40.9 [11.99]	40.5 [11.87]	38.4 [11.25]	37.5 [10.99]	37.2 [10.90]
		Power	8.9	9.2	9.4	8.9	9.2	9.4	8.9	9.2	9.4
	15 [32.2]	Total BTUH [kW]	51.1 [14.98]	50.0 [14.65]	49.6 [14.54]	47.7 [13.98]	46.6 [13.66]	46.2 [13.54]	44.3 [12.98]	43.3 [12.69]	42.9 [12.57]
		Power	8.5	8.8	9.0	8.5	8.8	9.0	8.5	8.8	9.0
	20 [-6.6]	Total BTUH [kW]	57.0 [16.71]	55.7 [16.32]	55.2 [16.18]	53.6 [15.71]	52.4 [15.36]	51.9 [15.21]	50.1 [14.68]	49.0 [14.36]	48.6 [14.24]
		Power	8.1	8.5	8.6	8.1	8.5	8.6	8.1	8.5	8.6
25 [37.8]	Total BTUH [kW]	62.9 [18.43]	61.5 [18.02]	60.9 [17.85]	59.4 [17.41]	58.1 [17.03]	57.6 [16.88]	56.0 [16.41]	54.8 [16.06]	54.3 [15.91]	
	Power	7.8	8.1	8.2	7.8	8.1	8.2	7.8	8.1	8.2	
30 [-1.1]	Total BTUH [kW]	68.7 [20.13]	67.2 [19.69]	66.6 [19.52]	65.3 [19.14]	63.9 [18.73]	63.3 [18.55]	61.8 [18.11]	60.5 [17.73]	60.0 [17.58]	
	Power	7.4	7.7	7.8	7.4	7.7	7.8	7.4	7.7	7.8	
35 [43.3]	Total BTUH [kW]	74.6 [21.86]	73.0 [21.39]	72.3 [21.19]	71.1 [20.84]	69.6 [20.40]	69.0 [20.22]	67.7 [19.84]	66.2 [19.40]	65.6 [19.23]	
	Power	7.0	7.3	7.4	7.0	7.3	7.4	7.0	7.3	7.4	
40 [4.4]	Total BTUH [kW]	80.4 [23.56]	78.7 [23.06]	78.0 [22.86]	77.0 [22.57]	75.3 [22.07]	74.7 [21.89]	73.6 [21.57]	72.0 [21.10]	71.3 [20.90]	
	Power	6.7	7.0	7.1	6.7	7.0	7.1	6.7	7.0	7.1	
45 [46.1]	Total BTUH [kW]	86.3 [25.29]	84.4 [24.74]	83.7 [24.53]	82.9 [24.30]	81.1 [23.77]	80.3 [23.53]	79.4 [23.27]	77.7 [22.77]	77.0 [22.57]	
	Power	6.3	6.6	6.7	6.3	6.6	6.7	6.3	6.6	6.7	
50 [10]	Total BTUH [kW]	92.2 [27.02]	90.2 [26.44]	89.4 [26.20]	88.7 [26.00]	86.8 [25.44]	86.0 [25.20]	85.3 [25.00]	83.4 [24.44]	82.7 [24.24]	
	Power	6.0	6.2	6.3	6.0	6.2	6.3	6.0	6.2	6.3	

IDB—Indoor air dry bulb

[] Designates Metric Conversions





COOLING PERFORMANCE DATA—B120

ENTERING INDOOR AIR @ 80°F [26.7°C] dbE ①											
wbE		71°F [21.7°C]			67°F [19.4°C]			63°F [17.2°C]			
CFM [L/s]		4560 [2152]	4000 [1888]	3040 [1435]	4560 [2152]	4000 [1888]	3040 [1435]	4560 [2152]	4000 [1888]	3040 [1435]	
DR ①		.03	.05	.01	.03	.05	.01	.03	.05	.01	
OUTDOOR DRY BULB TEMPERATURE °F [°C]	75 [23.9]	Total BTUH [kW] Sens BTUH [kW] Power	151.2 [44.3] 115.7 [33.9] 8.0	147.4 [43.2] 104.8 [30.7] 7.9	141.0 [41.3] 87.4 [25.6] 7.8	141.4 [41.4] 132.2 [38.8] 8.0	137.9 [40.4] 120.6 [35.4] 7.9	131.8 [38.6] 101.7 [29.8] 7.7	135.2 [39.6] 135.2 [39.6] 7.9	131.8 [38.6] 131.8 [38.6] 7.8	126.1 [37.0] 113.0 [33.1] 7.6
	80 [26.7]	Total BTUH [kW] Sens BTUH [kW] Power	148.0 [43.4] 107.4 [31.5] 8.4	144.4 [42.3] 97.2 [28.5] 8.3	138.1 [40.5] 80.7 [23.7] 8.1	138.2 [40.5] 124.0 [36.4] 8.3	134.8 [39.5] 113.0 [33.1] 8.2	128.9 [37.8] 95.1 [27.9] 8.0	132.0 [38.7] 132.0 [38.7] 8.2	128.7 [37.7] 125.3 [36.7] 8.1	123.1 [36.1] 106.3 [31.2] 8.0
	85 [29.4]	Total BTUH [kW] Sens BTUH [kW] Power	144.8 [42.4] 100.5 [29.5] 8.8	141.2 [41.4] 90.7 [26.6] 8.7	135.0 [39.6] 75.0 [22.0] 8.5	134.9 [39.5] 116.9 [34.3] 8.7	131.6 [38.6] 106.4 [31.2] 8.6	125.8 [36.9] 89.3 [26.2] 8.4	128.7 [37.7] 128.7 [37.7] 8.6	125.5 [36.8] 118.7 [34.8] 8.5	120.1 [35.2] 100.6 [29.5] 8.3
	90 [32.2]	Total BTUH [kW] Sens BTUH [kW] Power	141.4 [41.4] 94.5 [27.7] 9.2	137.9 [40.4] 85.2 [25.0] 9.1	131.9 [38.7] 70.3 [20.6] 8.9	131.6 [38.6] 111.0 [32.5] 9.1	128.3 [37.6] 100.9 [29.6] 9.0	122.7 [36.0] 84.6 [24.8] 8.8	125.4 [36.8] 124.1 [36.4] 9.0	122.3 [35.8] 113.4 [33.2] 8.9	116.9 [34.3] 95.9 [28.1] 8.7
	95 [35]	Total BTUH [kW] Sens BTUH [kW] Power	138.0 [40.4] 89.8 [26.3] 9.7	134.6 [39.4] 80.9 [23.7] 9.5	128.7 [37.7] 66.6 [19.5] 9.3	128.2 [37.6] 106.3 [31.2] 9.6	125.0 [36.6] 96.6 [28.3] 9.4	119.5 [35.0] 80.9 [23.7] 9.2	122.0 [35.8] 119.3 [35.0] 9.5	118.9 [34.8] 108.9 [31.9] 9.4	113.7 [33.3] 92.1 [27.0] 9.2
	100 [37.8]	Total BTUH [kW] Sens BTUH [kW] Power	134.5 [39.4] 86.3 [25.3] 10.1	131.2 [38.5] 77.7 [22.8] 10.0	125.4 [36.8] 63.8 [18.7] 9.8	124.7 [36.5] 102.8 [30.1] 10.0	121.6 [35.6] 93.4 [27.4] 9.9	116.3 [34.1] 78.2 [22.9] 9.7	118.5 [34.7] 115.8 [33.9] 9.9	115.5 [33.8] 105.7 [31.0] 9.8	110.5 [32.4] 89.4 [26.2] 9.6
	105 [40.6]	Total BTUH [kW] Sens BTUH [kW] Power	130.9 [38.4] 83.8 [24.6] 10.6	127.6 [37.4] 75.4 [22.1] 10.5	122.1 [35.8] 62.1 [18.2] 10.3	121.1 [35.5] 100.4 [29.4] 10.5	118.1 [34.6] 91.2 [26.7] 10.4	112.9 [33.1] 76.4 [22.4] 10.2	114.9 [33.7] 113.5 [33.3] 10.4	112.0 [32.8] 103.6 [30.4] 10.3	107.1 [31.4] 87.6 [25.7] 10.1
	110 [43.3]	Total BTUH [kW] Sens BTUH [kW] Power	127.2 [37.3] 82.6 [24.2] 11.1	124.1 [36.4] 74.4 [21.8] 11.0	118.6 [34.8] 61.2 [17.9] 10.8	117.4 [34.4] 99.1 [29.1] 11.1	114.5 [33.6] 90.1 [26.4] 10.9	109.5 [32.1] 75.6 [22.2] 10.7	111.2 [32.6] 111.2 [32.6] 11.0	108.4 [31.8] 102.5 [30.0] 10.8	103.7 [30.4] 86.8 [25.4] 10.6
	115 [46.1]	Total BTUH [kW] Sens BTUH [kW] Power	123.5 [36.2] 82.6 [24.2] 11.7	120.4 [35.3] 74.4 [21.8] 11.6	115.1 [33.7] 61.4 [18.0] 11.3	113.6 [33.3] 99.0 [29.0] 11.5	110.8 [32.5] 90.1 [26.4] 11.5	106.0 [31.1] 75.7 [22.2] 11.2	107.4 [31.5] 107.4 [31.5] 11.5	104.7 [30.7] 102.5 [30.0] 11.4	100.2 [29.4] 87.0 [25.5] 11.1

DR —Depression ratio
dbE —Entering air dry bulb
wbE—Entering air wet bulb

Total —Total capacity x 1000 BTUH
Sens —Sensible capacity x 1000 BTUH
Power —KW input

NOTES:

① When the entering air dry bulb is other than 80°F [27°C], adjust the sensible capacity from the table by adding [1.10 x CFM x (1 – DR) x (dbE – 80)].

HEATING PERFORMANCE DATA—B120

IDB		60°F [15.5°C]			70°F [21.1°C]			80°F [26.7°C]			
CFM [L/s]		4560 [2152]	4000 [1888]	3040 [1435]	4560 [2152]	4000 [1888]	3040 [1435]	4560 [2152]	4000 [1888]	3040 [1435]	
OUTDOOR DRY BULB TEMPERATURE °F [°C]	0 [-17.8]	Total BTUH [kW] Power	45.2 [13.25] 11.3	44.7 [13.10] 11.5	43.9 [12.87] 11.8	41.7 [12.22] 11.3	41.3 [12.10] 11.5	40.6 [11.90] 11.8	38.3 [11.22] 11.3	37.9 [11.11] 11.5	37.3 [10.93] 11.8
	5 [26.7]	Total BTUH [kW] Power	51.9 [15.21] 10.9	51.4 [15.06] 11.1	50.5 [14.80] 11.4	48.5 [14.21] 10.9	48.0 [14.07] 11.1	47.2 [13.83] 11.4	45.0 [13.19] 10.9	44.6 [13.07] 11.1	43.8 [12.84] 11.4
	10 [-12.2]	Total BTUH [kW] Power	58.6 [17.17] 10.5	58.0 [17.00] 10.7	57.1 [16.73] 11.0	55.2 [16.18] 10.5	54.7 [16.03] 10.7	53.7 [15.74] 11.0	51.8 [15.18] 10.5	51.3 [15.03] 10.7	50.4 [14.77] 11.0
	15 [32.2]	Total BTUH [kW] Power	65.4 [19.17] 10.2	64.7 [18.96] 10.3	63.6 [18.64] 10.7	61.9 [18.14] 10.2	61.3 [17.97] 10.3	60.3 [17.67] 10.7	58.5 [17.14] 10.2	57.9 [16.97] 10.3	56.9 [16.68] 10.7
	20 [-6.6]	Total BTUH [kW] Power	72.1 [21.13] 9.8	71.4 [20.93] 10.0	70.2 [20.57] 10.3	68.7 [20.13] 9.8	68.0 [19.93] 10.0	66.8 [19.58] 10.3	65.2 [19.11] 9.8	64.6 [18.93] 10.0	63.5 [18.61] 10.3
	25 [37.8]	Total BTUH [kW] Power	78.8 [23.09] 9.4	78.1 [22.89] 9.6	76.7 [22.48] 9.9	75.4 [22.10] 9.4	74.7 [21.89] 9.6	73.4 [21.51] 9.9	72.0 [21.10] 9.4	71.3 [20.90] 9.6	70.0 [20.51] 9.9
	30 [-1.1]	Total BTUH [kW] Power	85.6 [25.09] 9.1	84.7 [24.82] 9.2	83.3 [24.41] 9.5	82.2 [24.09] 9.1	81.3 [23.83] 9.2	79.9 [23.42] 9.5	78.7 [23.06] 9.1	77.9 [22.83] 9.2	76.6 [22.45] 9.5
	35 [43.3]	Total BTUH [kW] Power	92.3 [27.05] 8.7	91.4 [26.79] 8.8	89.8 [26.32] 9.1	88.9 [26.05] 8.7	88.0 [25.79] 8.8	86.5 [25.35] 9.1	85.5 [25.06] 8.7	84.6 [24.79] 8.8	83.2 [24.38] 9.1
	40 [4.4]	Total BTUH [kW] Power	99.1 [29.04] 8.3	98.1 [28.75] 8.5	96.4 [28.25] 8.7	95.6 [28.02] 8.3	94.7 [27.75] 8.5	93.1 [27.28] 8.7	92.2 [27.02] 8.3	91.3 [26.76] 8.5	89.7 [26.29] 8.7
	45 [46.1]	Total BTUH [kW] Power	105.8 [31.01] 7.9	104.7 [30.68] 8.1	103.0 [30.19] 8.3	102.4 [30.01] 7.9	101.3 [29.69] 8.1	99.6 [29.19] 8.3	98.9 [28.98] 7.9	98.0 [28.72] 8.1	96.3 [28.22] 8.3
50 [10]	Total BTUH [kW] Power	112.5 [32.97] 7.6	111.4 [32.65] 7.7	109.5 [32.09] 7.9	109.1 [31.97] 7.6	108.0 [31.65] 7.7	106.2 [31.12] 7.9	105.7 [30.98] 7.6	104.6 [30.66] 7.7	102.8 [30.13] 7.9	

IDB—Indoor air dry bulb

[] Designates Metric Conversions



AIRFLOW PERFORMANCE—7.5 TON [26.4 kW] — SIDEFLOW

Air Flow CFM [L/s]	External Static Pressure—Inches of Water [kPa]																																							
	Model RJNL-B090																																							
	Voltage 208/230, 460, 575—3 Phase																																							
	0.1 [0.02]	0.2 [0.05]	0.3 [0.07]	0.4 [0.10]	0.5 [0.12]	0.6 [0.15]	0.7 [0.17]	0.8 [0.20]	0.9 [0.22]	1.0 [0.25]	1.1 [0.27]	1.2 [0.30]	1.3 [0.32]	1.4 [0.35]	1.5 [0.37]	1.6 [0.40]	1.7 [0.42]	1.8 [0.45]	1.9 [0.47]	2.0 [0.50]																				
	RPM	W	RPM	W	RPM	W	RPM	W	RPM	W	RPM	W	RPM	W	RPM	W	RPM	W	RPM	W																				
2400 [1133]	—	—	550	810	582	845	614	883	645	924	677	968	708	1015	740	1066	771	1119	802	1175	833	1234	864	1296	895	1361	924	1435	955	1508	985	1584	1016	1663	1046	1744	1077	1829	1107	1916
2500 [1180]	—	—	559	839	590	876	622	916	653	959	684	1004	715	1053	745	1105	776	1160	807	1218	837	1279	867	1343	897	1410	927	1490	957	1564	987	1641	1017	1721	1047	1804	1077	1890	1107	1979
2600 [1227]	—	—	569	872	600	910	630	952	661	997	691	1044	722	1095	752	1149	782	1205	812	1265	842	1328	871	1394	901	1462	931	1546	961	1622	990	1701	1019	1782	1049	1866	1078	1954	1107	2044
2700 [1274]	549	870	579	908	610	948	640	982	670	1038	699	1088	729	1140	759	1196	788	1255	818	1316	847	1381	876	1448	905	1519	935	1606	964	1683	993	1763	1022	1846	1050	1931	1079	2020	1107	2111
2800 [1321]	561	909	591	948	620	990	650	1036	679	1084	708	1135	737	1190	766	1247	795	1308	824	1371	853	1437	881	1507	910	1579	940	1667	968	1746	996	1827	1025	1911	1052	1998	1080	2088	1108	2181
2900 [1368]	573	951	602	992	631	1036	660	1083	689	1134	718	1187	746	1243	775	1302	803	1365	831	1430	860	1498	888	1569	915	1644	945	1732	973	1811	1000	1894	1028	1980	1055	2068	1082	2159	1109	2253
3000 [1416]	586	997	615	1040	643	1086	672	1135	700	1187	728	1242	756	1300	784	1361	812	1425	839	1492	867	1563	894	1636	923	1720	950	1798	977	1879	1004	1963	1031	2050	1058	2140	1084	2233	1111	2328
3100 [1463]	600	1047	628	1092	656	1140	684	1190	711	1244	739	1301	766	1361	794	1424	821	1490	848	1559	875	1631	902	1706	929	1787	956	1867	982	1950	1009	2035	1035	2123	1061	2215	1087	2309	1113	2405
3200 [1510]	615	1101	642	1147	669	1197	697	1250	724	1305	751	1364	777	1426	804	1491	831	1558	857	1629	884	1703	910	1780	936	1857	962	1939	988	2022	1013	2109	1039	2199	1064	2291	1090	2387	1115	2485
3300 [1557]	630	1158	657	1207	683	1258	710	1313	736	1370	763	1431	789	1495	815	1561	841	1631	857	1703	893	1779	919	1858	943	1930	968	2012	993	2098	1018	2186	1043	2277	1068	2371	1093	2468	1117	2567
3400 [1604]	646	1220	672	1270	698	1324	724	1380	750	1439	776	1502	801	1567	827	1636	852	1707	878	1781	903	1859	925	1924	950	2005	975	2089	999	2175	1024	2265	1048	2357	1072	2453	1096	2551	1120	2652
3500 [1652]	662	1285	688	1337	713	1393	739	1451	764	1512	789	1576	814	1644	839	1714	864	1787	889	1863	914	1943	933	2000	958	2082	982	2167	1006	2255	1029	2346	1053	2440	1077	2537	1100	2636	1124	2739
3600 [1699]	679	1355	704	1409	729	1466	754	1526	779	1589	804	1655	828	1724	853	1796	877	1871	901	1949	918	1998	942	2078	966	2162	989	2249	1012	2338	1035	2430	1058	2525	1081	2623	1104	2724	1127	2828

NOTE: L-Drive left section, M-Drive center section, N-Drive right section.

Drive Package	L						M						N					
	1	2	3	4	5	6	1	2	3	4	5	6	1	2	3	4	5	6
Motor H.P. [W]	3.0 [2237.1]																	
Blower Sheave	BK90H																	
Motor Sheave	1VP-44																	
Turns Open	708	676	646	612	580	548	868	830	794	752	713	673	1192	1134	1085	1031	979	919

NOTES: 1. Factory sheave settings are shown in bold type.

2. Do not set motor sheave below minimum or maximum turns open shown.

3. Re-adjustment of sheave required to achieve rated airflow at AHR1 minimum External Static Pressure

4. Drive data shown is for horizontal airflow with dry coil. Add component resistance (below) to duct resistance to determine total External Static Pressure.

AIRFLOW CORRECTION FACTORS—7.5 TON [26.4 kW]

ACTUAL—CFM [L/s]	Standard Indoor Airflow—CFM [L/s]												
	2400 [1133]	2500 [1180]	2600 [1227]	2700 [1274]	2800 [1321]	2900 [1368]	3000 [1416]	3100 [1463]	3200 [1510]	3300 [1557]	3400 [1604]	3500 [1652]	3600 [1699]
TOTAL MBH	0.97	0.97	0.98	0.98	0.99	1.00	1.00	1.01	1.02	1.02	1.02	1.02	1.02
SENSIBLE MBH	0.87	0.90	0.92	0.94	0.97	0.99	1.02	1.04	1.06	1.06	1.06	1.06	1.06
POWER kW	0.98	0.98	0.99	0.99	1.00	1.00	1.00	1.01	1.01	1.01	1.01	1.01	1.01

NOTES: 1. Multiply correction factor times gross performance data.

2. Resulting sensible capacity cannot exceed total capacity.

[] Designates Metric Conversions

COMPONENT AIRFLOW RESISTANCE—7.5 TON [26.4 kW]

Component	Resistance—Inches Water [kPa]																	
	2400 [1133]	2500 [1180]	2600 [1227]	2700 [1274]	2800 [1321]	2900 [1368]	3000 [1416]	3100 [1463]	3200 [1510]	3300 [1557]	3400 [1604]	3500 [1652]	3600 [1699]					
Wet Coil	0.09	0.10	0.10	0.11	0.11	0.12	0.12	0.13	0.13	0.13	0.13	0.14	0.14					
Downflow	0.08	0.08	0.09	0.09	0.10	0.10	0.11	0.11	0.11	0.11	0.11	0.11	0.11					
Downflow Economizer RA Damper Open	0.10	0.10	0.11	0.11	0.12	0.12	0.13	0.13	0.13	0.14	0.14	0.15	0.15					
Horizontal Economizer RA Damper Open	0.10	0.10	0.11	0.11	0.12	0.12	0.13	0.13	0.13	0.14	0.14	0.15	0.15					
Concentric Grill with RXRN-FA65 or RXRN-FA75 with Transition RXMC-CC04	0.13	0.15	0.17	0.19	0.21	0.23	0.25	0.28	0.31	0.34	0.37	0.40	0.44					

208/240 VOLT, THREE PHASE, 60 HZ, AUXILIARY ELECTRIC HEATER KITS CHARACTERISTICS AND APPLICATION														
Separate Power Supply for Both Unit and Heater Kit														
Model No. RJNL-	Single Power Supply for Both Unit and Heater Kit							Heater Kit						
	RXJJ-Heater Kit Nominal kW	No. of Sequence Steps	Rated Heater kW @ 208/240V	Heater kBTU/Hr @ 208/240V	Heater Amps @ 208/240V	Unit Min. Ckt. Ampacity @ 208/240V	Over Current Protective Device Size		Min. Ckt. Ampacity 208/240V	Max. Fuse Size 208/240V	Min. Circuit Ampacity 208/240V	Over Current Protective Device Size		
							Min./Max. 208V	Min./Max. 240V				Min./Max. 208V	Min./Max. 240V	
B090CL	No Heat	—	—	—	—	43/43	—	50/60	—	43/43	—	50/60	—	
	CC15C	1	10.8/14.4	36.84/49.13	30.1/34.7	81/87	30.1/34.7	90/90	38/44	40/45	—	—	—	
	CC20C	1	14.4/19.2	49.13/65.5	40/46.2	93/101	40/46.2	100/100	50/58	50/60	—	—	—	
	CC30C	1	21.6/28.8	73.69/98.25	60.2/69.4	119/130	60.2/69.4	125/125	76/87	80/90	—	—	—	
B090CM	CC40C	1	28.8/38.4	98.25/131	80.1/92.4	144/159	80.1/92.4	150/150	101/116	110/125	—	—	—	
	No Heat	—	—	—	—	43/43	—	50/60	—	43/43	—	50/60	—	
	CC15C	1	10.8/14.4	36.84/49.13	30.1/34.7	81/87	30.1/34.7	90/90	38/44	40/45	—	—	—	
	CC20C	1	14.4/19.2	49.13/65.5	40/46.2	93/101	40/46.2	100/100	50/58	50/60	—	—	—	
B090CN	CC30C	1	21.6/28.8	73.69/98.25	60.2/69.4	119/130	60.2/69.4	125/125	76/87	80/90	—	—	—	
	CC40C	1	28.8/38.4	98.25/131	80.1/92.4	144/159	80.1/92.4	150/150	101/116	110/125	—	—	—	
	No Heat	—	—	—	—	45/45	—	60/60	—	45/45	—	60/60	—	
	CC15C	1	10.8/14.4	36.84/49.13	30.1/34.7	83/89	30.1/34.7	100/100	38/44	40/45	—	—	—	
B120CL	CC20C	1	14.4/19.2	49.13/65.5	40/46.2	95/103	40/46.2	110/110	50/58	50/60	—	—	—	
	CC30C	1	21.6/28.8	73.69/98.25	60.2/69.4	121/132	60.2/69.4	150/150	76/87	80/90	—	—	—	
	CC40C	1	28.8/38.4	98.25/131	80.1/92.4	146/161	80.1/92.4	175/175	101/116	110/125	—	—	—	
	No Heat	—	—	—	—	50/50	—	60/70	—	50/50	—	60/70	—	
B120CM	CC15C	1	10.8/14.4	36.84/49.13	30.1/34.7	88/94	30.1/34.7	100/110	38/44	40/45	—	—	—	
	CC20C	1	14.4/19.2	49.13/65.5	40/46.2	100/108	40/46.2	110/110	50/58	50/60	—	—	—	
	CC30C	1	21.6/28.8	73.69/98.25	60.2/69.4	126/137	60.2/69.4	150/150	76/87	80/90	—	—	—	
	CC40C	1	28.8/38.4	98.25/131	80.1/92.4	151/166	80.1/92.4	175/175	101/116	110/125	—	—	—	
B120CN	No Heat	—	—	—	—	52/52	—	60/80	—	52/52	—	60/80	—	
	CC15C	1	10.8/14.4	36.84/49.13	30.1/34.7	90/96	30.1/34.7	100/110	38/44	40/45	—	—	—	
	CC20C	1	14.4/19.2	49.13/65.5	40/46.2	102/110	40/46.2	110/110	50/58	50/60	—	—	—	
	CC30C	1	21.6/28.8	73.69/98.25	60.2/69.4	128/139	60.2/69.4	150/150	76/87	80/90	—	—	—	
B120CN	CC40C	1	28.8/38.4	98.25/131	80.1/92.4	153/168	80.1/92.4	175/175	101/116	110/125	—	—	—	

*= For Canadian use only. Uses "p" fuses for inductive circuit.
 + = Field installed only.

480 VOLT, THREE PHASE, 60 HZ, AUXILIARY ELECTRIC HEATER KITS CHARACTERISTICS AND APPLICATION														
Separate Power Supply for Both Unit and Heater Kit														
Single Power Supply for Both Unit and Heater Kit														
Model No. RJNL-	Heater Kit				Heat Pump				Heater Kit				Heat Pump	
	RXJL- Heater Kit Nominal kW	No. of Sequence Steps	Rated Heater kW @ 480V	Heater kBTU/Hr @ 480V	Heater Amps @ 480V	Unit Min. Ampacity @ 480V	Over Current Protective Device Size Min./Max. 480V	Min. Ckt. Ampacity 480V	Max. Fuse Size 480V	Min. Circuit Ampacity 480V	Over Current Protective Device Size Min./Max. 480V	Min. Ckt. Ampacity 480V	Max. Fuse Size 480V	Over Current Protective Device Size Min./Max. 480V
B090DL	No Heat	—	—	—	—	21	25/30	—	—	21	25/30	—	—	—
	CC15D	1	14.4	49.13	17.4	43	50/50	—	25	—	—	—	25	—
	CC20D	1	19.2	65.5	23.1	50	60/60	—	30	—	—	—	30	—
	CC30D	1	28.8	98.25	34.7	65	70/70	—	45	—	—	—	45	—
B090DM	CC40D	1	38.4	131	46.2	79	90/90	—	60	—	—	—	60	—
	No Heat	—	—	—	—	21	25/30	—	—	21	25/30	—	—	—
	CC15D	1	14.4	49.13	17.4	43	50/50	—	25	—	—	—	25	—
	CC20D	1	19.2	65.5	23.1	50	60/60	—	30	—	—	—	30	—
B090DN	CC30D	1	28.8	98.25	34.7	65	70/70	—	45	—	—	—	45	—
	CC40D	1	38.4	131	46.2	79	90/90	—	60	—	—	—	60	—
	No Heat	—	—	—	—	22	25/30	—	—	22	25/30	—	—	—
	CC15D	1	14.4	49.13	17.4	44	50/50	—	25	—	—	—	25	—
B120DL	CC20D	1	19.2	65.5	23.1	51	60/60	—	30	—	—	—	30	—
	CC30D	1	28.8	98.25	34.7	66	80/80	—	45	—	—	—	45	—
	CC40D	1	38.4	131	46.2	80	90/90	—	60	—	—	—	60	—
	No Heat	—	—	—	—	28	35/40	—	—	28	35/40	—	—	—
B120DM	CC15D	1	14.4	49.13	17.4	50	60/60	—	25	—	—	—	25	—
	CC20D	1	19.2	65.5	23.1	57	60/60	—	30	—	—	—	30	—
	CC30D	1	28.8	98.25	34.7	72	80/80	—	45	—	—	—	45	—
	CC40D	1	38.4	131	46.2	86	90/90	—	60	—	—	—	60	—
B120DN	No Heat	—	—	—	—	29	35/45	—	—	29	35/45	—	—	—
	CC15D	1	14.4	49.13	17.4	51	60/60	—	25	—	—	—	25	—
	CC20D	1	19.2	65.5	23.1	58	70/70	—	30	—	—	—	30	—
	CC30D	1	28.8	98.25	34.7	73	80/80	—	45	—	—	—	45	—
B120DN	CC40D	1	38.4	131	46.2	87	100/100	—	60	—	—	—	60	—

*= For Canadian use only. Uses "P" fuses for inductive circuit.
 + = Field installed only.



600 VOLT, THREE PHASE, 60 HZ, AUXILIARY ELECTRIC HEATER KITS CHARACTERISTICS AND APPLICATION													
Separate Power Supply for Both Unit and Heater Kit													
Model No. RJNL-	Single Power Supply for Both Unit and Heater Kit					Heater Kit				Heat Pump			
	RXJJ-Heater Kit Nominal kW	No. of Sequence Steps	Rated Heater kW @ 600V	Heater kBTU/Hr @ 600V	Heater Amps @ 600V	Unit Min. Ampacity @ 600V	Over Current Protective Device Size Min./Max. 600V	Min. Ampacity 600V	Max. Fuse Size 600V	Min. Circuit Ampacity 600V	Over Current Protective Device Size Min./Max. 600V	Heat Pump	Heat Pump
B090YL	No Heat	—	—	—	—	16	20/20	—	—	16	20/20	—	—
	CC15Y	1	14.4	49.13	13.9	34	40/40	18	20	—	—	—	—
	CC20Y	1	19.2	65.5	18.5	40	45/45	24	25	—	—	—	—
	CC30Y	1	28.8	98.25	28.9	53	60/60	37	40	—	—	—	—
B090YM	CC40Y	1	38.4	131	38.5	65	70/70	49	50	—	—	—	—
	No Heat	—	—	—	—	16	20/20	—	—	16	20/20	—	—
	CC15Y	1	14.4	49.13	13.9	34	40/40	18	20	—	—	—	—
	CC20Y	1	19.2	65.5	18.5	40	45/45	24	25	—	—	—	—
B090YN	CC30Y	1	28.8	98.25	28.9	53	60/60	37	40	—	—	—	—
	CC40Y	1	38.4	131	38.5	65	70/70	49	50	—	—	—	—
	No Heat	—	—	—	—	17	20/25	—	—	17	20/25	—	—
	CC15Y	1	14.4	49.13	13.9	35	45/45	18	20	—	—	—	—
B120YL	CC20Y	1	19.2	65.5	18.5	41	50/50	24	25	—	—	—	—
	CC30Y	1	28.8	98.25	28.9	54	60/60	37	40	—	—	—	—
	CC40Y	1	38.4	131	38.5	66	80/80	49	50	—	—	—	—
	No Heat	—	—	—	—	20	25/30	—	—	20	25/30	—	—
B120YM	CC15Y	1	14.4	49.13	13.9	38	45/45	18	20	—	—	—	—
	CC20Y	1	19.2	65.5	18.5	44	50/50	24	25	—	—	—	—
	CC30Y	1	28.8	98.25	28.9	57	60/60	37	40	—	—	—	—
	CC40Y	1	38.4	131	38.5	69	80/80	49	50	—	—	—	—
B120YN	No Heat	—	—	—	—	21	25/30	—	—	21	25/30	—	—
	CC15Y	1	14.4	49.13	13.9	39	50/50	18	20	—	—	—	—
	CC20Y	1	19.2	65.5	18.5	45	60/60	24	25	—	—	—	—
	CC30Y	1	28.8	98.25	28.9	58	70/70	37	40	—	—	—	—
CC40Y	1	38.4	131	38.5	70	80/80	49	50	—	—	—	—	—

*= For Canadian use only. Uses "P" fuses for inductive circuit.
+ = Field installed only.



ELECTRICAL DATA – RJNL- SERIES										
		B090CL	B090CM	B090CN	B090DL	B090DM	B090DN	B090YL	B090YM	B090YN
Unit Information	Unit Operating Voltage Range	187-253	187-253	187-253	414-506	414-506	414-506	517-632	517-632	517-632
	Volts	208/230	208/230	208/230	460	460	460	575	575	575
	Minimum Circuit Ampacity	43/43	43/43	45/45	21	21	22	16	16	17
	Minimum Overcurrent Protection Device Size	50/50	50/50	60/60	25	25	25	20	20	20
	Maximum Overcurrent Protection Device Size	60/60	60/60	60/60	30	30	30	20	20	25
Compressor Motor	No.	1	1	1	1	1	1	1	1	1
	Volts	200/230	200/230	200/230	460	460	460	575	575	575
	Phase	3	3	3	3	3	3	3	3	3
	RPM	3450	3450	3450	3450	3450	3450	3450	3450	3450
	HP, Compressor 1	10 1/4	10 1/4	10 1/4	10 1/4	10 1/4	10 1/4	10 1/4	10 1/4	10 1/4
	Amps (RLA), Comp. 1	25/25	25/25	25/25	12.2	12.2	12.2	9	9	9
	Amps (LRA), Comp. 1	164/164	164/164	164/164	100	100	100	78	78	78
	HP, Compressor 2	—	—	—	—	—	—	—	—	—
	Amps (RLA), Comp. 2	—	—	—	—	—	—	—	—	—
Amps (LRA), Comp. 2	—	—	—	—	—	—	—	—	—	
Condenser Motor	No.	2	2	2	2	2	2	2	2	2
	Volts	208/230	208/230	208/230	460	460	460	575	575	575
	Phase	1	1	1	1	1	1	1	1	1
	HP	1/3	1/3	1/3	1/3	1/3	1/3	1/3	1/3	1/3
	Amps (FLA, each)	2.4/2.4	2.4/2.4	2.4/2.4	1.4	1.4	1.4	1	1	1
	Amps (LRA, each)	3.9/3.9	3.9/3.9	3.9/3.9	1.8	1.8	1.8	1.5	1.5	1.5
Evaporator Fan	No.	1	1	1	1	1	1	1	1	1
	Volts	208/230	208/230	208/230	460	460	460	575	575	575
	Phase	3	3	3	3	3	3	3	3	3
	HP	2	2	3	2	2	3	2	2	3
	Amps (FLA, each)	8/8	8/8	13/13	4	4	7	4	4	8
	Amps (LRA, each)	56/56	56/56	74.5/74.5	28	28	38.1	19	19	20

ELECTRICAL DATA – RJNL- SERIES

		B120CL	B120CM	B120DL	B120DM	B120YL	B120YM
Unit Information	Unit Operating Voltage Range	187-253	187-253	414-506	414-506	517-632	517-632
	Volts	208/230	208/230	460	460	575	575
	Minimum Circuit Ampacity	50/50	52/52	28	29	20	21
	Minimum Overcurrent Protection Device Size	60/60	60/60	35	35	25	25
	Maximum Overcurrent Protection Device Size	70/70	80/80	40	45	30	30
Compressor Motor	No.	1	1	1	1	1	1
	Volts	200/230	200/230	460	460	575	575
	Phase	3	3	3	3	3	3
	RPM	3450	3450	3450	3450	3450	3450
	HP, Compressor 1	12 3/4	12 3/4	12 3/4	12 3/4	12 3/4	12 3/4
	Amps (RLA), Comp. 1	30.1/30.1	30.1/30.1	16.7	16.7	12.2	12.2
	Amps (LRA), Comp. 1	225/225	225/225	114	114	80	80
	HP, Compressor 2	—	—	—	—	—	—
	Amps (RLA), Comp. 2	—	—	—	—	—	—
Amps (LRA), Comp. 2	—	—	—	—	—	—	
Condenser Motor	No.	2	2	2	2	2	2
	Volts	208/230	208/230	460	460	575	575
	Phase	1	1	1	1	1	1
	HP	1/2	1/2	1/2	1/2	1/2	1/2
	Amps (FLA, each)	2.3/2.3	2.3/2.3	1.5	1.5	1	1
	Amps (LRA, each)	5.6/5.6	5.6/5.6	3.1	3.1	2.2	2.2
Evaporator Fan	No.	1	1	1	1	1	1
	Volts	208/230	208/230	460	460	575	575
	Phase	3	3	3	3	3	3
	HP	2	3	2	3	2	3
	Amps (FLA, each)	8/8	13/13	4	7	4	8
	Amps (LRA, each)	56/56	74.5/74.5	28	38.1	19	20

UNIT DIMENSIONS PACKAGE HEAT PUMPS

SUPPLY AND RETURN DIMENSIONS FOR HORIZONTAL APPLICATION

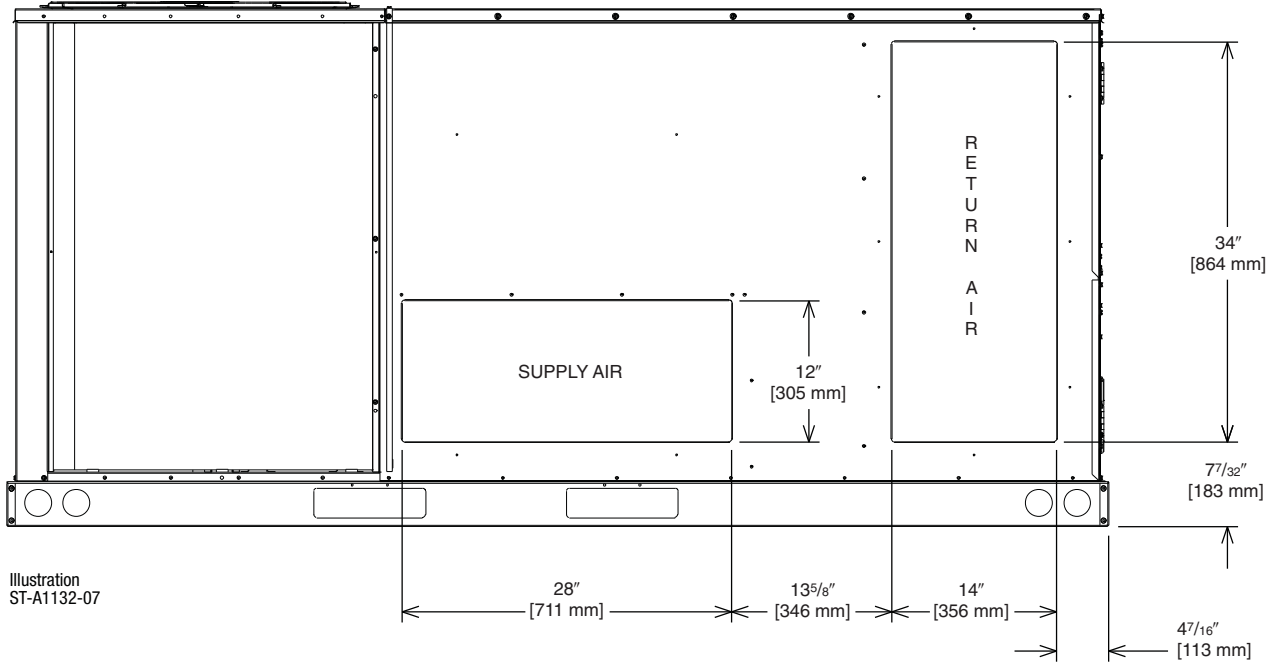

SUPPLY AND RETURN DIMENSIONS FOR DOWNFLOW APPLICATIONS

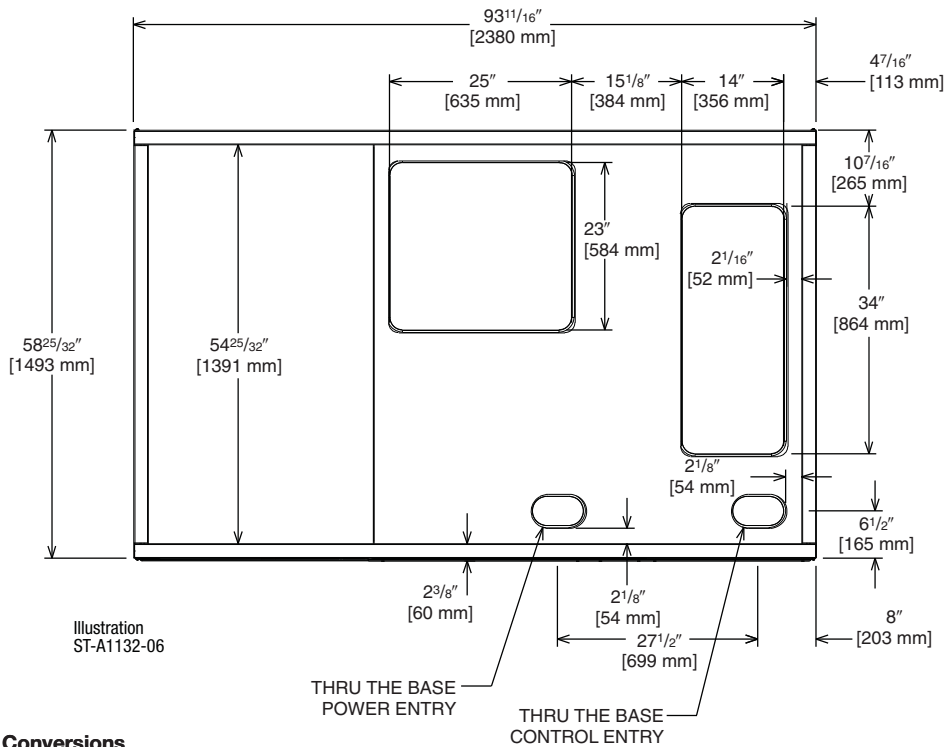

[] Designates Metric Conversions

UNIT DIMENSIONS PACKAGE HEAT PUMPS

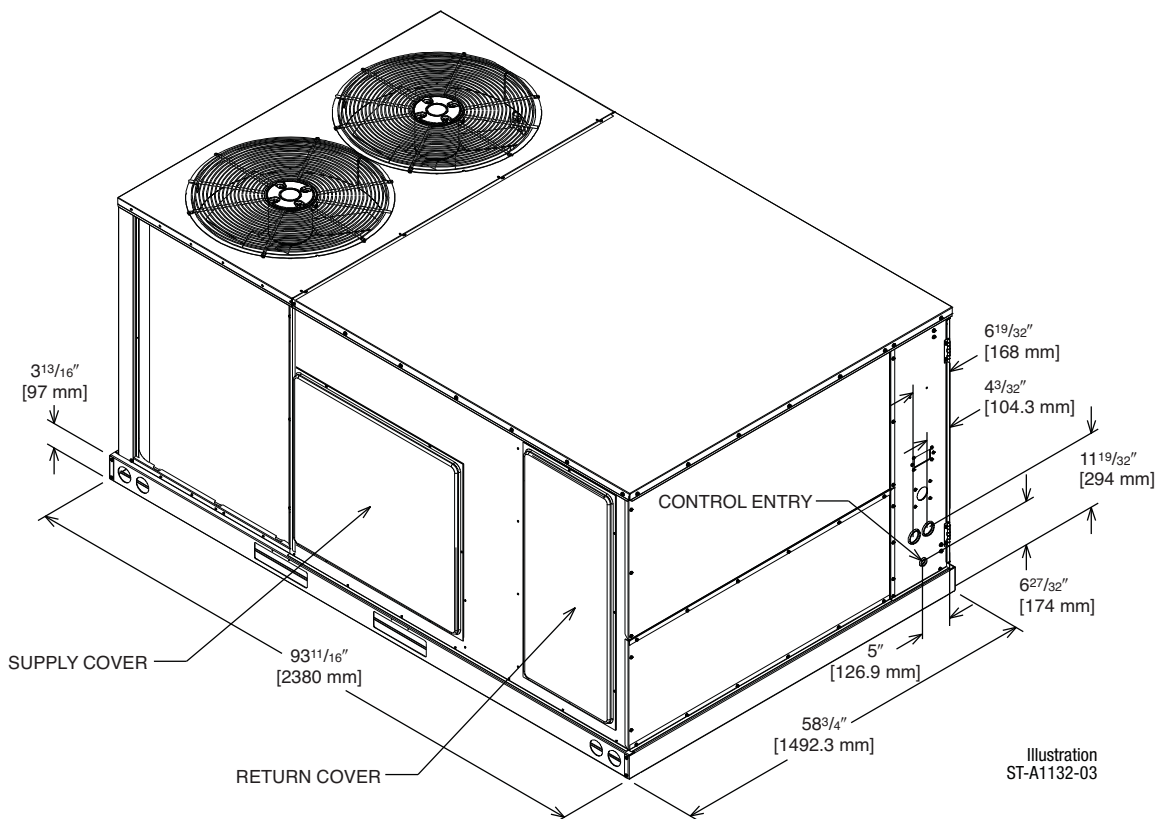

[] Designates Metric Conversions

CORNER WEIGHTS

Capacity Tons [kW]	Corner Weights by Percentage			
	A	B	C	D
7.5-10 [26.4-35.2]	32%	26%	20%	22%

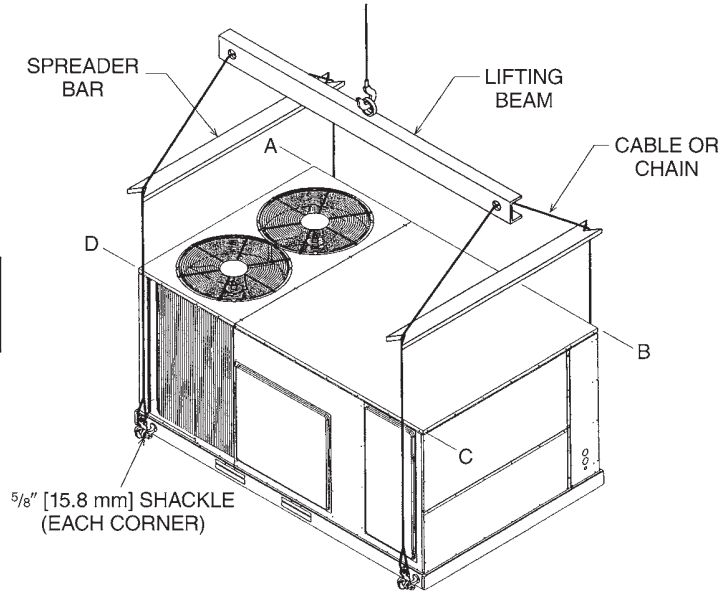

CLEARANCES

The following minimum clearances are recommended for proper unit performance and serviceability.

Recommended Clearance In. [mm]	Location
48 [1219]	A - Front
18 [457]	B - Condenser Coil
18 [457]	C - Duct Side
18 [457]	*D - Evaporator End
60 [1524]	E - Above
*Without Economizer. 48\" [1219 mm] With Economizer	

[] Designates Metric Conversions

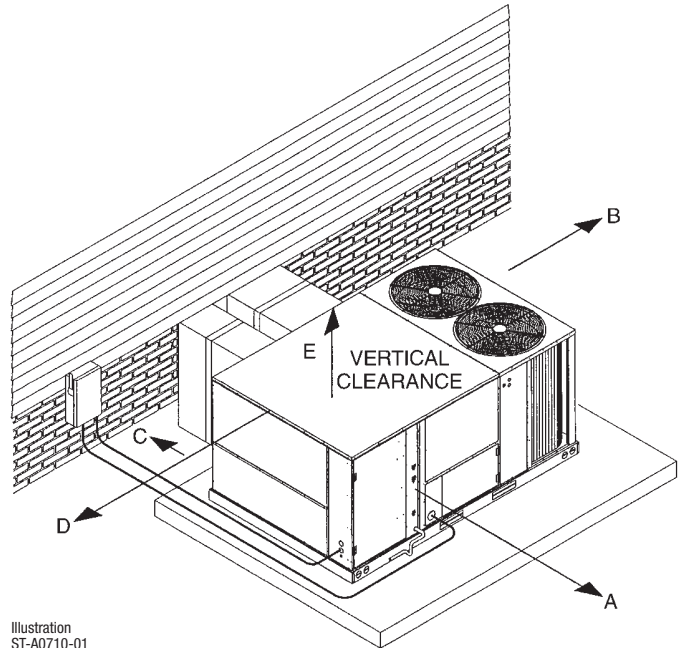

Illustration
ST-A0710-01

FIELD INSTALLED ACCESSORY EQUIPMENT

Accessory	Model Number	Shipping Weight Lbs. [kg]	Installed Weight Lbs. [kg]	Factory Installation Available?
Thermostats	See Thermostat Specification Sheet for Details (T11-001)			No
Electric Heaters	RXJJ-CC15 (C,D,Y)	46 [20.9]	36 [16.3]	Yes
	RXJJ-CC20 (C,D,Y)	46 [20.9]	36 [16.3]	Yes
	RXJJ-CC30 (C,D,Y)	47 [21.3]	37 [16.8]	Yes
	RXJJ-CC40 (C,D,Y)	49 [22.2]	39 [17.7]	Yes
Economizer w/Single Enthalpy	AXRD-PDCM3	90 [40.8]	81 [36.7]	Yes
Economizer w/Single Enthalpy and Smoke Detector	AXRD-SDCM3	91 [41.3]	82 [57.2]	Yes
Dual Enthalpy Kit	RXR-AR02	3 [1.4]	1 [0.5]	No
Horizontal Economizer w/Single Enthalpy	AXRD-RDCM3	94 [42.6]	89 [40.4]	No
Carbon Dioxide Sensor	RXR-AR02	3 [1.4]	2 [1.0]	No
Power Exhaust	RXR-BFF02 (C,D,Y)	43 [19.5]	38 [17.2]	No
Manual Fresh Air (Left Panel Mounted)	AXRF-KDA1	38 [17.2]	31 [14.0]	No
Manual Fresh Air (Return Panel)	AXRF-JDA1	26 [11.8]	21 [9.5]	No
Motorized Fresh Air (Return Panel)	AXRF-JDB1	43 [19.5]	38 [17.2]	No
Motor Kit for RXRF-KDA1	RXR-AW02	35 [15.9]	27 [12.2]	No
Roofcurb, 14"	RXKG-CAE14	90 [40.8]	85 [38.5]	No
Roofcurb, 24"	RXKG-CAE24	140 [63.5]	135 [61.2]	No
Roofcurb Adapters	RXR-CDCE50	300 [136.1]	290 [131.5]	No
	RXR-CFCE54	325 [147.4]	315 [142.9]	No
	RXR-CFCE56	350 [158.8]	340 [154.2]	No
	RXR-CGCC12	450 [204.1]	410 [186.0]	No
Concentric Diffuser (Step-Down, 20" Round)	RXR-FA65	139 [63.0]	60 [27.2]	No
Concentric Diffuser (Step-Down, 18 x 28)	RXR-AA61	200 [90.7]	185 [83.9]	No
Concentric Diffuser (Step-Down, 18 x 32)	RXR-AA66	247 [112.0]	227 [103.0]	No
Concentric Diffuser (Flush, 20" Round)	RXR-FA75	54 [24.4]	42 [19.0]	No
Concentric Diffuser (Flush, 18 x 28)	RXR-AA71	170 [77.1]	155 [70.3]	No
Concentric Diffuser (Flush, 18 x 32)	RXR-AA76	176 [79.8]	161 [73.0]	No
Downflow Transition (Rect. to Round)	RXMC-CD04 ①	15 [6.8]	13 [5.9]	No
Downflow Transition (Rect. to Rect., 18 x 28)	RXMC-CE05 ②	18 [8.2]	16 [7.3]	No
Downflow Transition (Rect. to Rect., 18 x 32)	RXMC-CF06 ③	20 [9.1]	18 [8.2]	No
Low-Ambient Control Kit	RXR-A03	3 [1.4]	2 [1.0]	Yes
Freeze-Stat Kit	RXR-AM05	1 [0.5]	0.5 [0.2]	Yes
Outdoor Coil Louver Kit (090)	AXRX-AAD01H	25 [11.3]	22 [10.0]	Yes
Outdoor Coil Louver Kit (120)	AXRX-AAD01J	29 [13.2]	26 [11.8]	Yes
Non-Powered Convenience Outlet	RXR-AN01	2 [1.0]	1.5 [0.7]	Yes

NOTES: ① Used with RXR-FA65 and RXR-FA75 concentric diffusers.
 ② Used with RXR-AA66 and RXR-AA76 concentric diffusers.
 ③ Used with RXR-AA66 and RXR-AA76 concentric diffusers.

[] Designates Metric Conversions

THERMOSTATS



200-Series *
 Programmable



300-Series *
 Deluxe Programmable

400-Series *
 Special Applications/
 Programmable



500-Series *
 Communicating/
 Programmable

Brand	Descriptor (3 Characters)	Series (3 Characters)	System (2 Characters)	Type (2 Characters)
RHC	- TST	213	UN	MS
RHC=Rheem	TST=Thermostat	200=Programmable 300=Deluxe Programmable 400=Special Applications/ Programmable 500=Communicating/ Programmable	GE=Gas/Electric UN=Universal (AC/HP/GE) MD=Modulating Furnace DF=Dual Fuel CM=Communicating	SS=Single-Stage MS=Multi-Stage

* Photos are representative. Actual models may vary.

For detailed thermostat match-up information,
 see specification sheet form number T11-001.

ECONOMIZERS

Use to Select Factory Installed Options Only

- AXRD-PDCM3—Single Enthalpy (Outdoor)**
- AXRD-SDCM3—Single Enthalpy w/Smoke Detector**
- RXXR-AV02—Dual Enthalpy Upgrade Kit**
- RXXR-AR02—Optional Wall-Mounted CO₂ Sensor**

- Features **Honeywell** Controls
- Available Factory Installed or Field Accessory
- Gear Driven Direct Drive Actuator
- Fully Modulating (0-100%)
- Low Leakage Dampers
- Slip-In Design for Easy Installation
- Plug-In Polarized 12-pin Electrical Connections
- Pre-Configured—No Field Adjustments Necessary
- Standard Barometric Relief Damper
- Single Enthalpy with Dual Enthalpy Upgrade Kit Available
- CO₂ Input Sensor Available
- Field Assembled Hood Ships with Economizer
- Economizer Ships Complete for Downflow Duct Application.
- Optional Remote Minimum Position Potentiometer (Honeywell #S963B1128) is Available from Prostock.
- Field Installed Power Exhaust Available
- Prewired for Smoke Detector

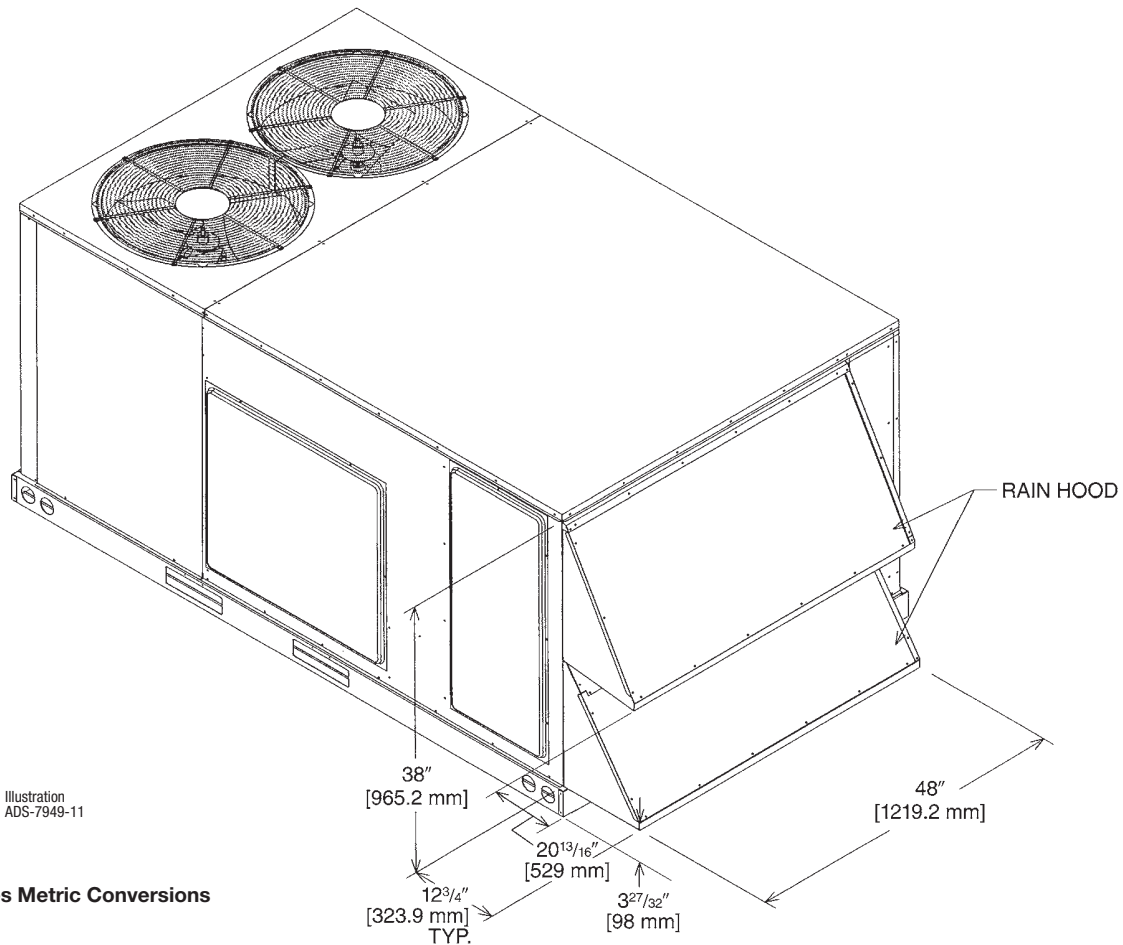
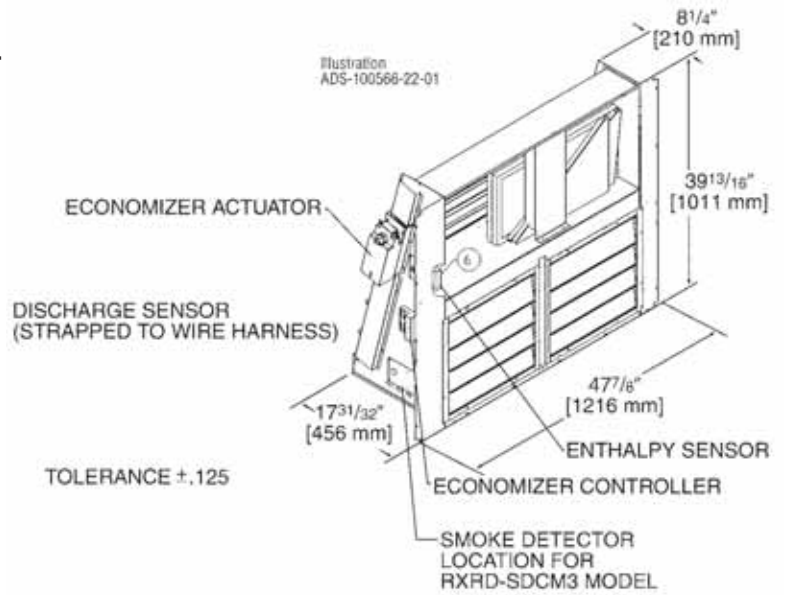

[] Designates Metric Conversions

ECONOMIZER FOR HORIZONTAL DUCT INSTALLATION

Field Installed Only

AXRD-RDCM3—Single Enthalpy (Outdoor)
RXXR-AV02—Dual Enthalpy Upgrade Kit
RXXR-AR02—Wall-mounted CO₂ Sensor

- Features **Honeywell** Controls
- Available as a Field Installed Accessory Only
- Gear Driven Direct Drive Actuator
- Fully Modulating (0-100%)
- Low Leakage Dampers
- Slip-In Design for Easy Installation
- Plug-In Polarized 12-pin Electrical Connections
- Pre-Configured—
No Field Adjustments Necessary
- Standard Barometric Relief Damper
- Single Enthalpy with Dual Enthalpy Upgrade Kit Available
- CO₂ Input Sensor Available
- Field Assembled Hood Ships with Economizer
- Economizer Ships Complete for Horizontal Duct Application
- Optional Remote Minimum Position Potentiometer (Honeywell #S963B1128) is Available from Prostock
- Field Installed Power Exhaust Available

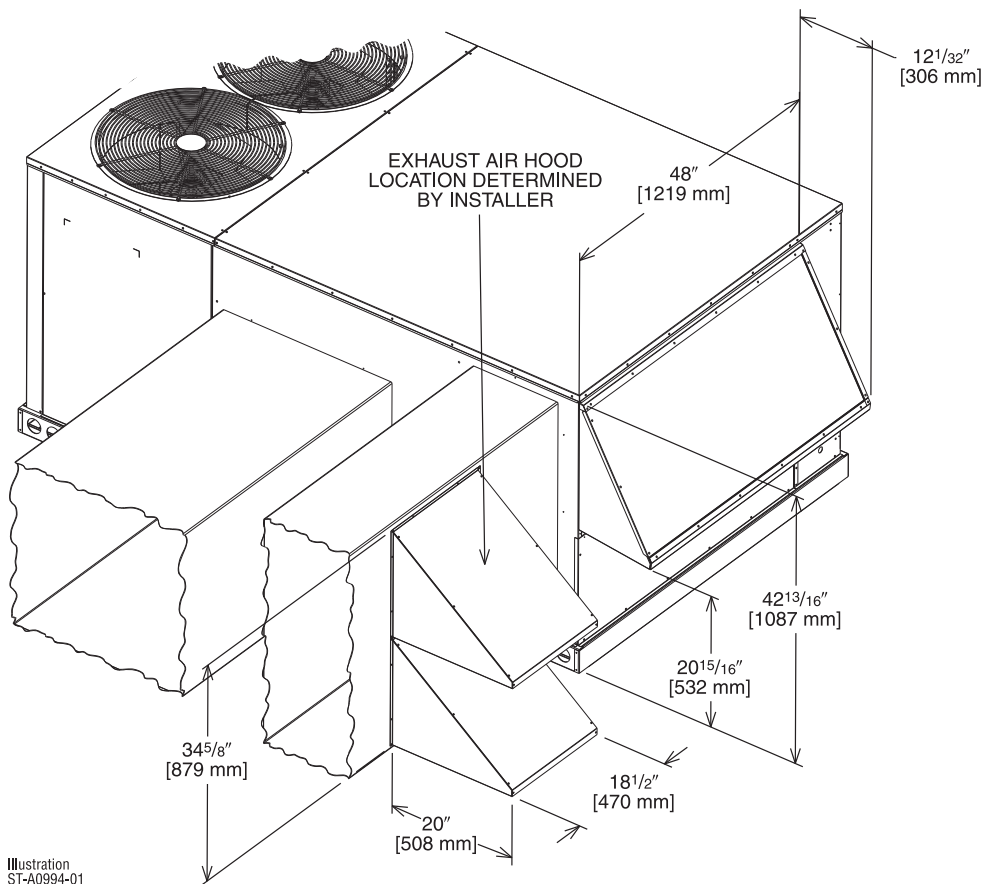
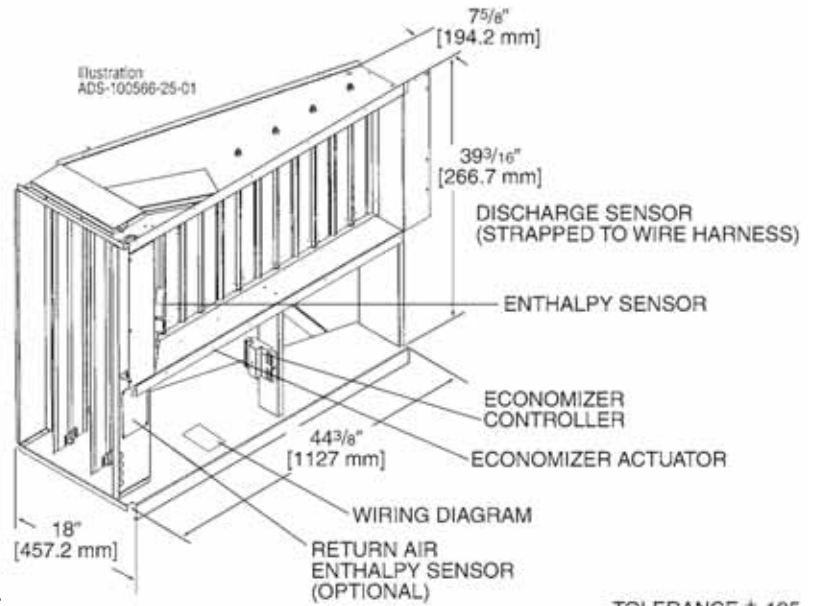

[] Designates Metric Conversions

POWER EXHAUST KIT FOR RXRD-PDCM3(-), RXRD-RDCM3(-), AXRD-SDCM3 ECONOMIZERS

RXXR-BFF02 (C, D, or Y*)

*Voltage Code

VERTICAL AIRFLOW

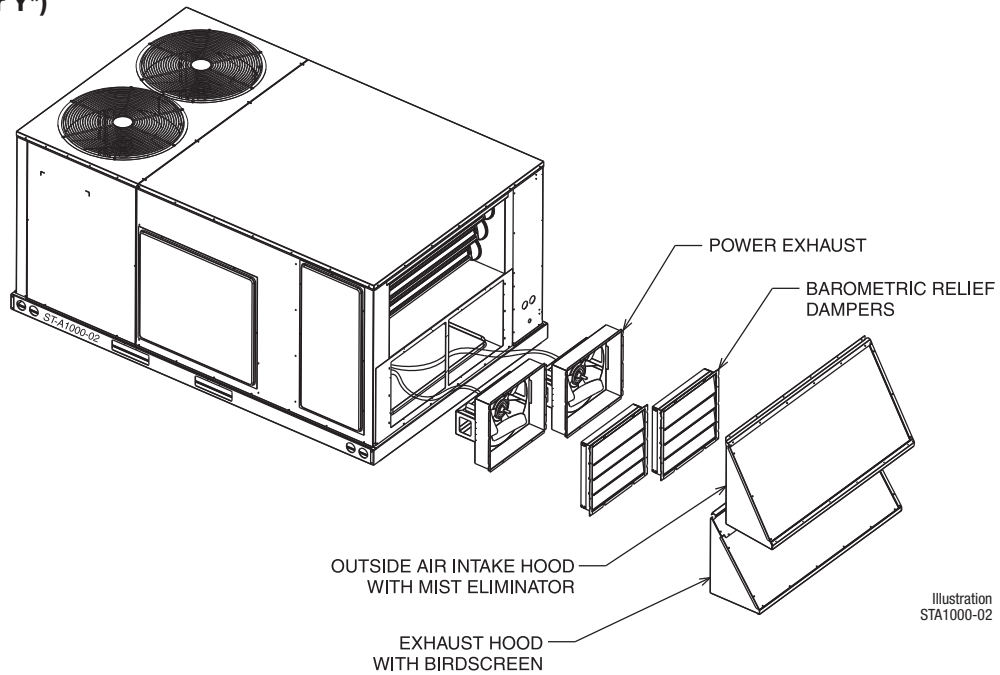

Illustration
STA1000-02

HORIZONTAL AIRFLOW

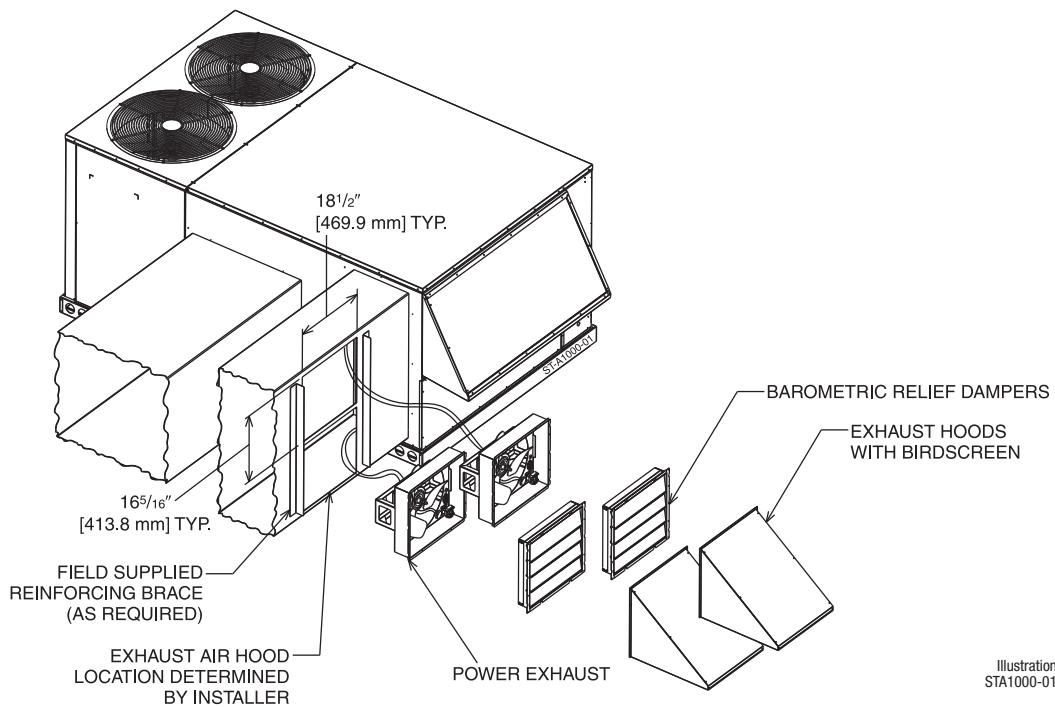

Illustration
STA1000-01

Model No.	No. of Fans	Volts	Phase	HP (ea.)	Low Speed		High Speed ①		FLA (ea.)	LRA (ea.)
					CFM [L/s] ②	RPM	CFM [L/s] ②	RPM		
RXXR-BFF02C	2	208-230	1	0.33	2200 [1038]	1518	2500 [1179]	1670	1.48	3.6
RXXR-BFF02D	2	460	1	0.33	2200 [1038]	1518	2500 [1179]	1670	0.75	1.8
RXXR-BFF02Y	2	575	1	0.33	2200 [1038]	1518	2500 [1179]	1670	0.81	1.5

NOTES: ① Power exhaust is factory set on high speed motor tap.

② CFM is per fan at 0" w.c. external static pressure.

[] Designates Metric Conversions

FRESH AIR DAMPER

MOTORIZED DAMPER KIT
RXRX-AW02
(Motor Kit for RXRF-KDA1)

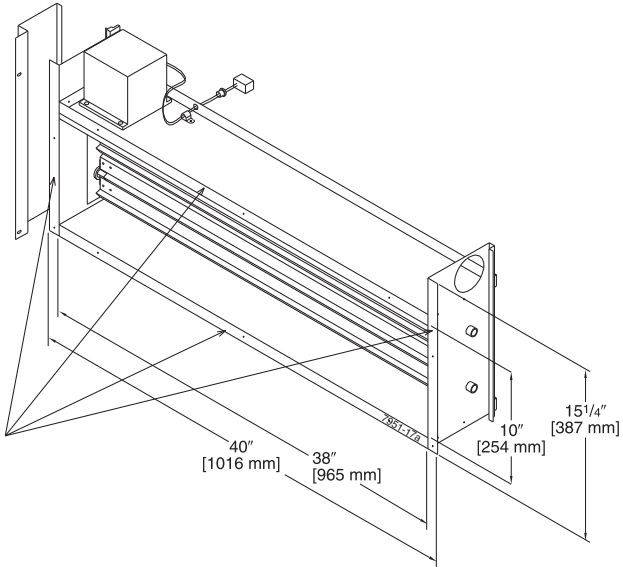

Illustration
 ST-7951-17

[] Designates Metric Conversions

AXRF-KDA1 (Manual)
DOWNFLOW OR
HORIZONTAL APPLICATION

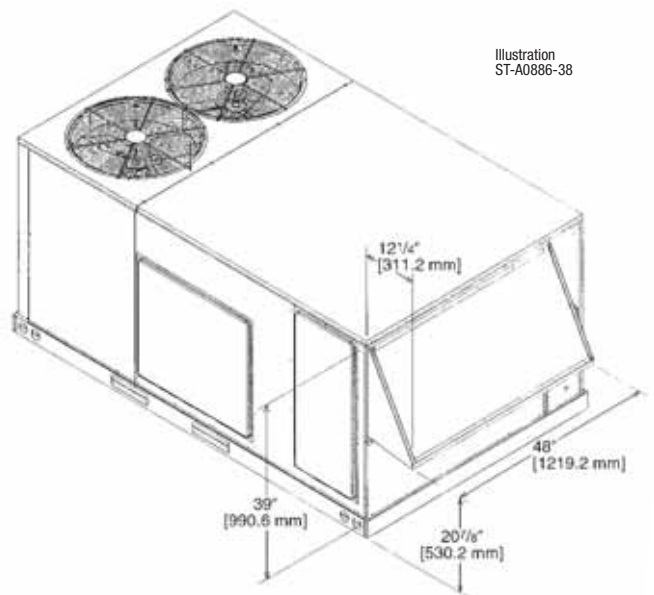

Illustration
 ST-A0886-38

FRESH AIR DAMPER (Cont.)

AXRF-JDA1 (Manual)
AXRF-JDB1 (Motorized)

DOWNFLOW APPLICATION

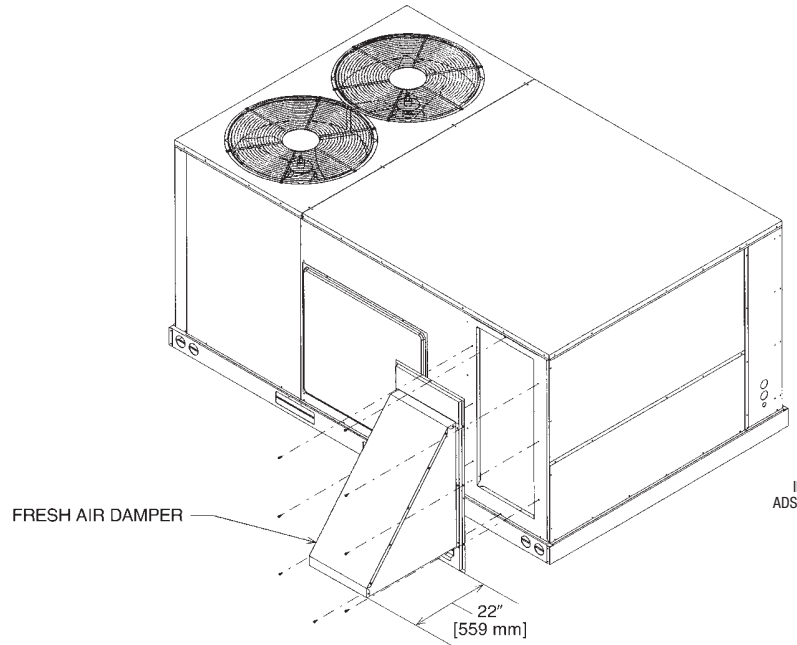
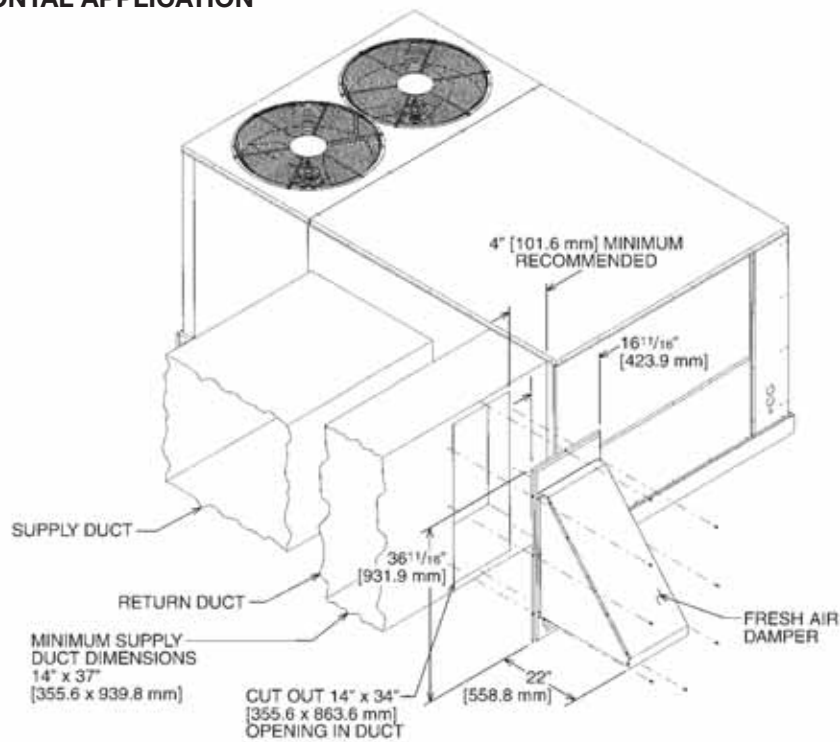

Illustration
ADS-7937-58

HORIZONTAL APPLICATION

Illustration
ST-A0901-01



[] Designates Metric Conversions

ROOFCURBS (Full Perimeter)

- Rheem’s new roofcurb design can be utilized on 7.5 and 10 ton [26.4 and 35.2 kW] RJNL-B models.
- Two available heights (14" [356 mm] and 24" [610 mm]) for ALL models.
- Quick assembly corners for simple and fast assembly.
- Opening provided in bottom pan to match the “Thru the Curb” electrical connection opening provided on the unit base pan.
- 2" [51 mm] x 4" [102 mm] Nailers provided.
- Insulating panels not required because of insulated outdoor base pan.
- Sealing gasket (28" [711 mm]) provided with Roofcurb.
- Packaged for easy field assembly.

Roofcurb Model	Height of Curb
RXKG-CAE14	14" [356 mm]
RXKG-CAE24	24" [610 mm]

ROOFCURB INSTALLATION

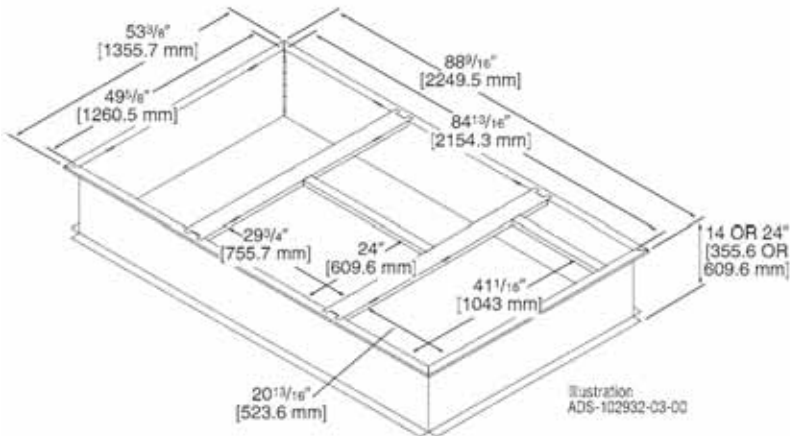

TYPICAL INSTALLATION

Illustration
ST-A0743-02

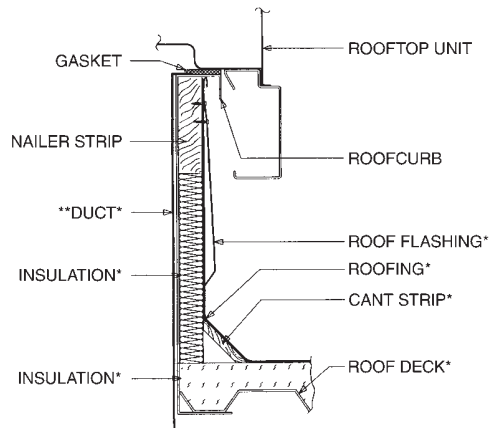
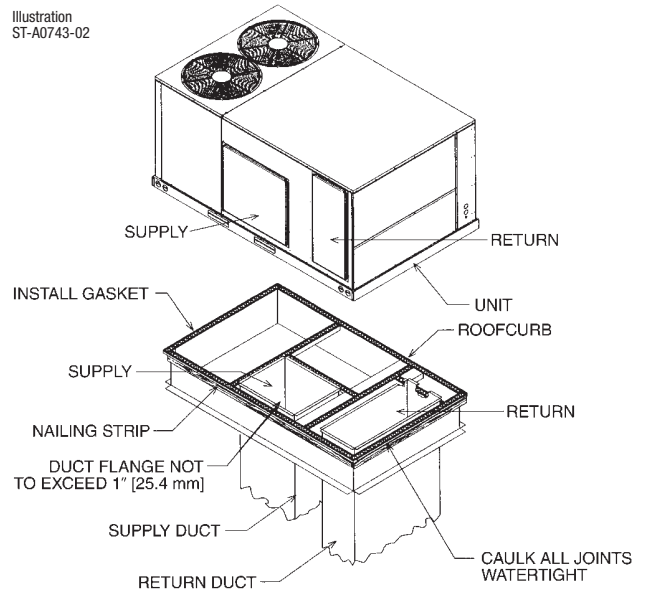

*BY CONTRACTOR

**FOR INSTALLATION OF DUCT AS SHOWN, USE RECOMMENDED DUCT SIZES FROM ROOFCURB INSTALLATION INSTRUCTIONS. FOR DUCT FLANGE ATTACHMENT TO UNIT, SEE UNIT INSTALLATION INSTRUCTIONS FOR RECOMMENDED DUCT SIZES.

Illustration
ST-A0743-02

[] Designates Metric Conversions

ROOFCURB ADAPTERS

OLD MODELS	OLD ROOFCURB	ROOFCURB ADAPTER	NEW MODELS (All Share Common Footprint)
(-)RCF, (-)REF-075/076 (-)RGF-150075, (-)RGF-131076 (-)RGF-201076	RXRK-E50	RXRX-CDCE50	
(-)RGF-200075 (-)RGG, (-)REG, (-)RCG-075 (-)RGF, (-)REF, (-)RCF-085 (-)RGF, (-)REF, (-)RCF-100 (-)RGG, (-)REG, (-)RCG-100	RXRK-E54	RXRX-CFCE54	(-)JNL-B090 (-)JNL-B120
(-)RGF, (-)REF, (-)RCF-125	RXRK-E56	RXRX-CFCE56	
(-)PDC-075 (-)PDC-100/101	RXPK-C12	RXRX-CGCC12	

NOTE: Ductwork modifications may be necessary if the capacity and/or indoor airflow rate of replacement unit is not equivalent to that of the unit being replaced.

ROOFCURB ADAPTERS (Cont.)

RXXR-CDCE50

Illustration
ADS-7952-02
Sheet 2

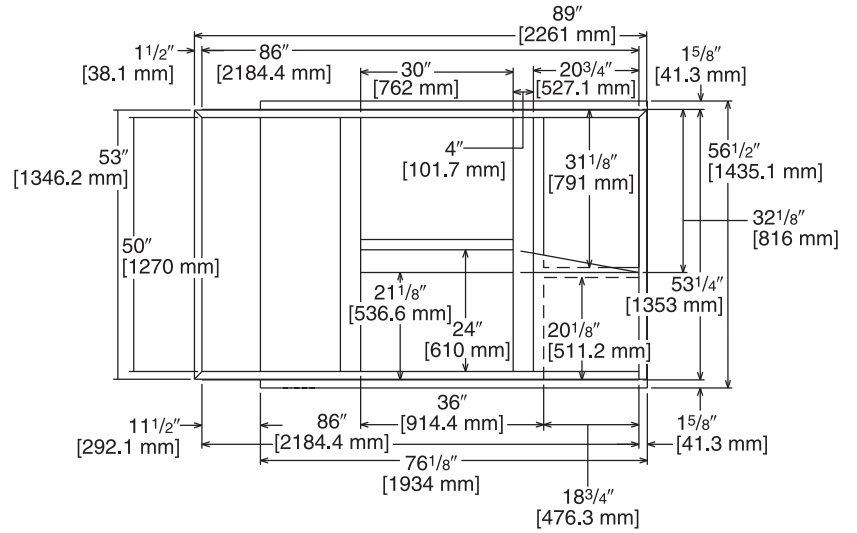

TOP VIEW

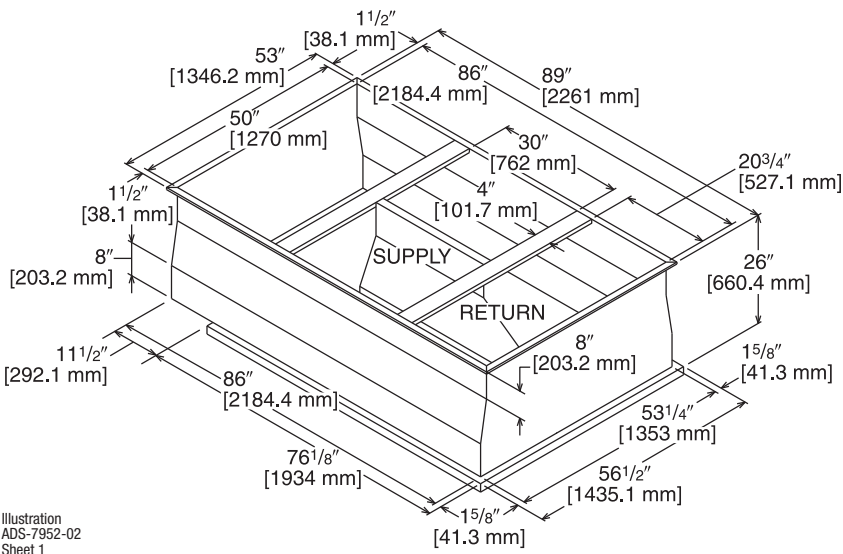

Illustration
ADS-7952-02
Sheet 1

[] Designates Metric Conversions

ROOFCURB ADAPTERS (Cont.)

RXRX-CFCE54

Illustration
ADS-7952-01
Sheet 2

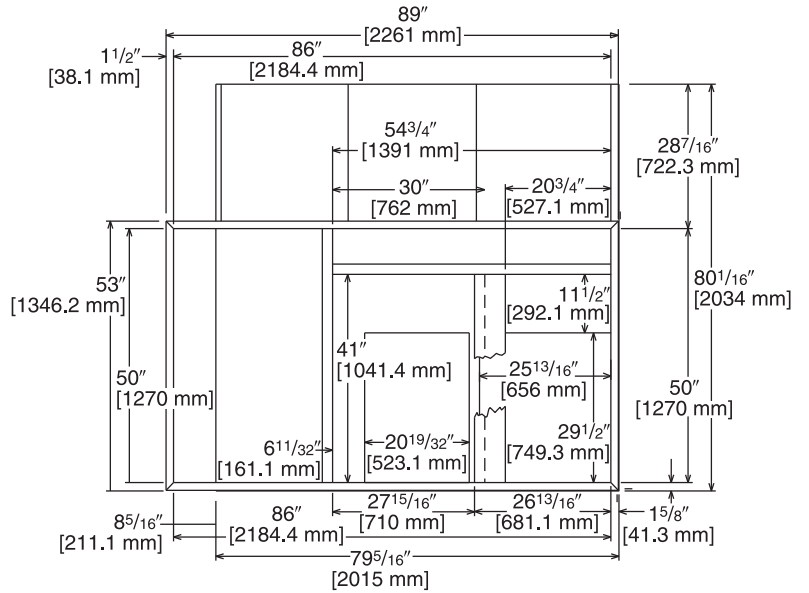

TOP VIEW

Illustration
ADS-7952-01
Sheet 1

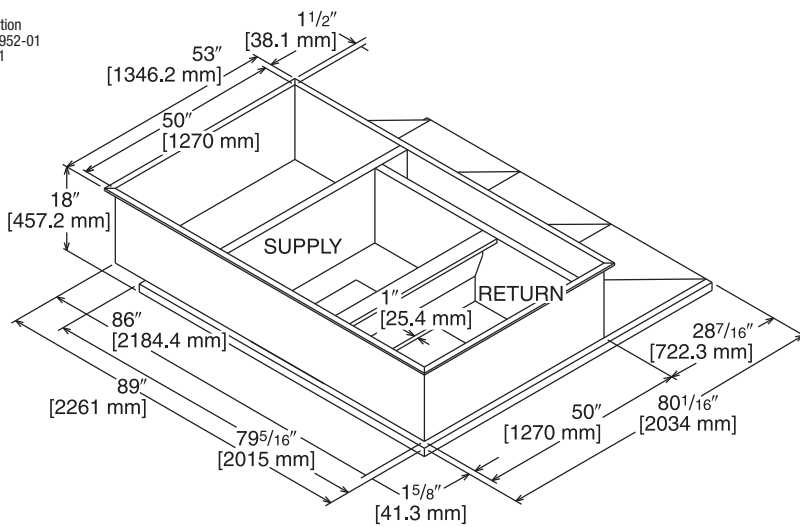

[] Designates Metric Conversions

ROOFCURB ADAPTERS (Cont.)

RXXR-CFCE56

Illustration
ADS-7952-03
Sheet 2

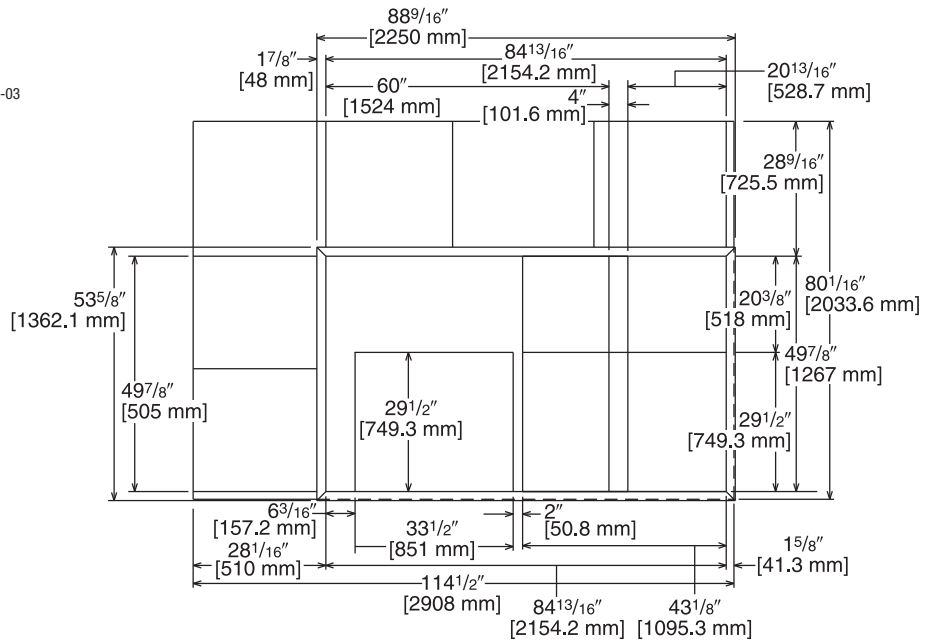

TOP VIEW

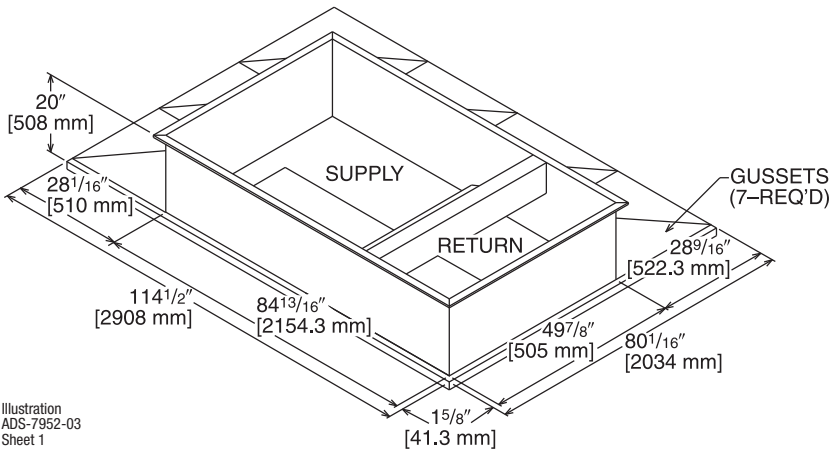

Illustration
ADS-7952-03
Sheet 1

[] Designates Metric Conversions

ROOFCURB ADAPTERS (Cont.)

RXRX-CGCC12

Illustration
ADS-7952-04
Sheet 2

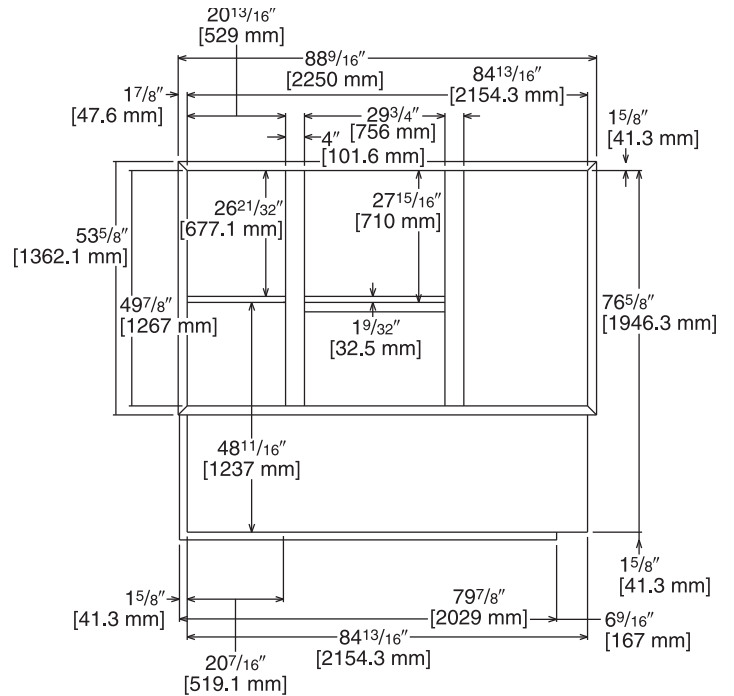

TOP VIEW

Illustration
ADS-7952-04
Sheet 1

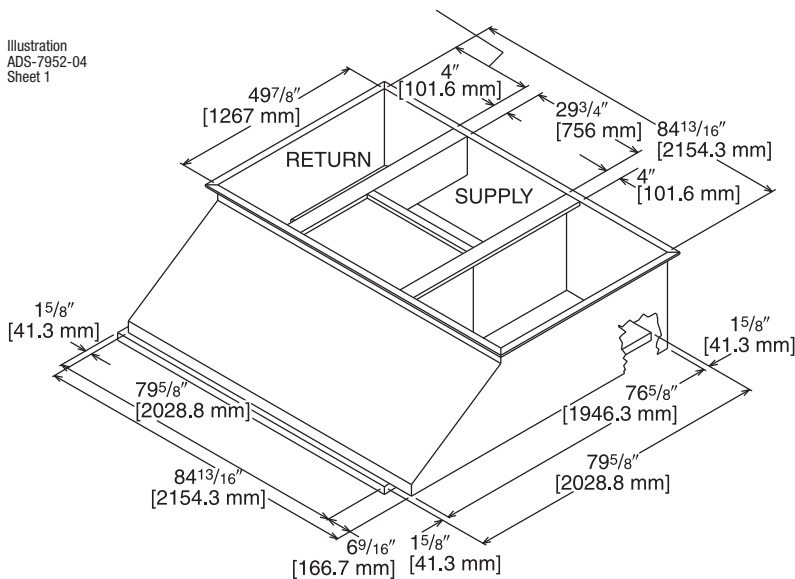

[] Designates Metric Conversions

CONCENTRIC DIFFUSER APPLICATION

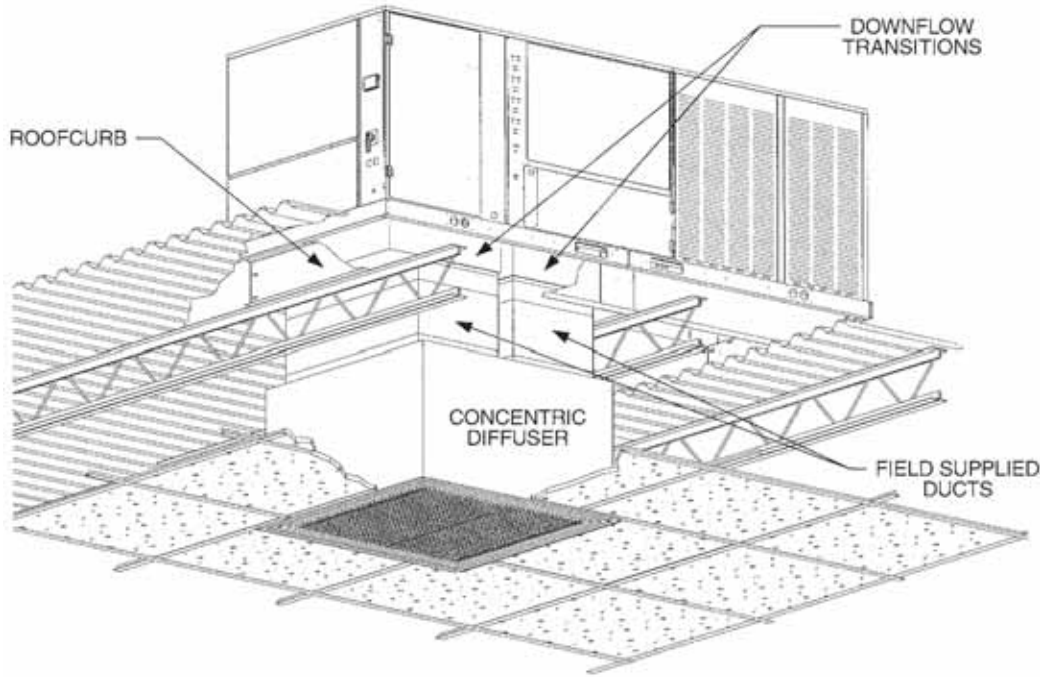

Illustration
 ST-A0840-02

DOWNFLOW TRANSITION DRAWINGS

RXMC-CE05

- Used with RXRN-AA61 or RXRN-AA71 Concentric Diffusers.

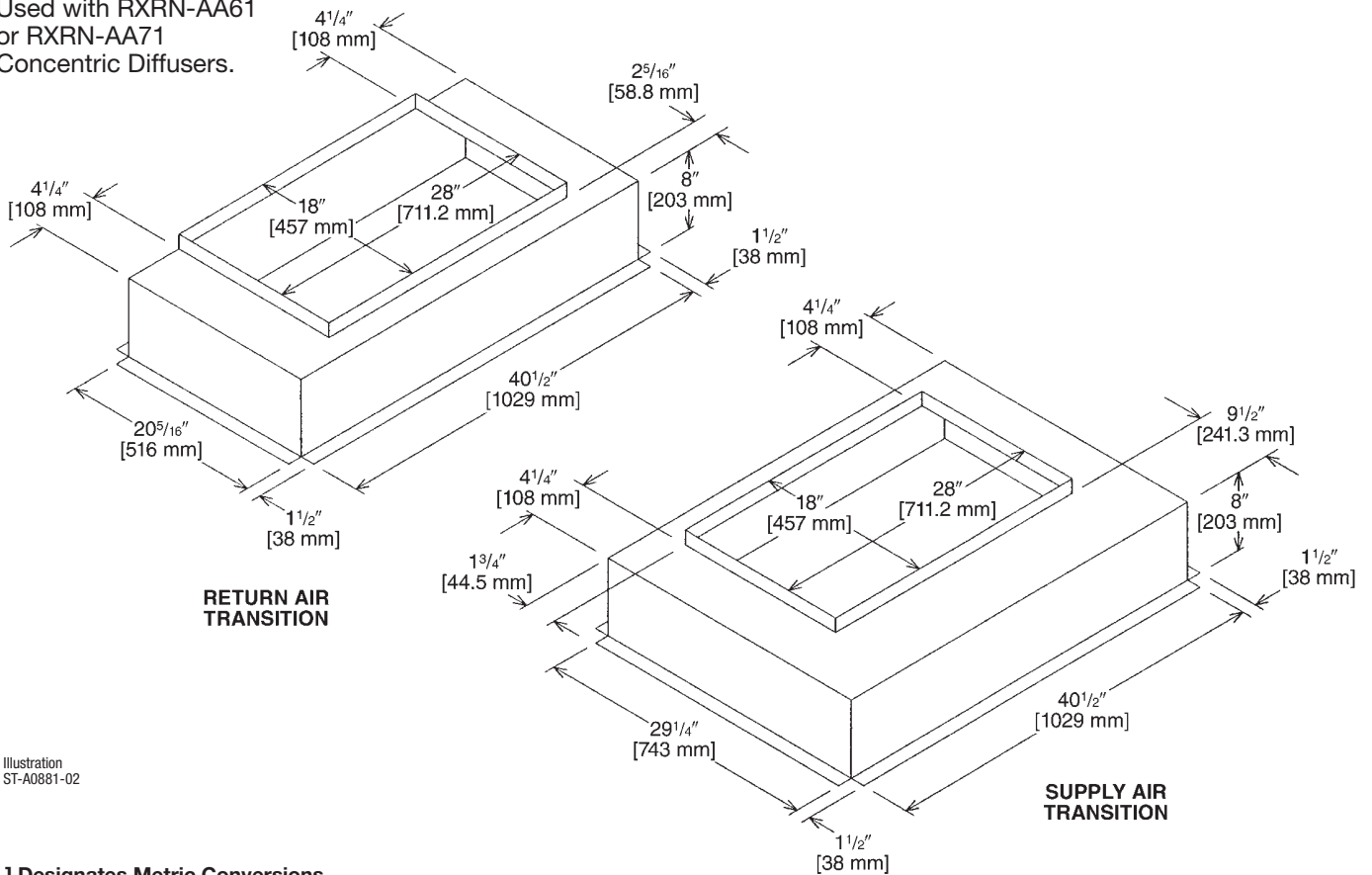

Illustration
 ST-A0881-02

[] Designates Metric Conversions

DOWNFLOW TRANSITION DRAWINGS (Cont.)

RXMC-CF06

- Used with RXRN-AA66 or RXRN-AA76 Concentric Diffusers.

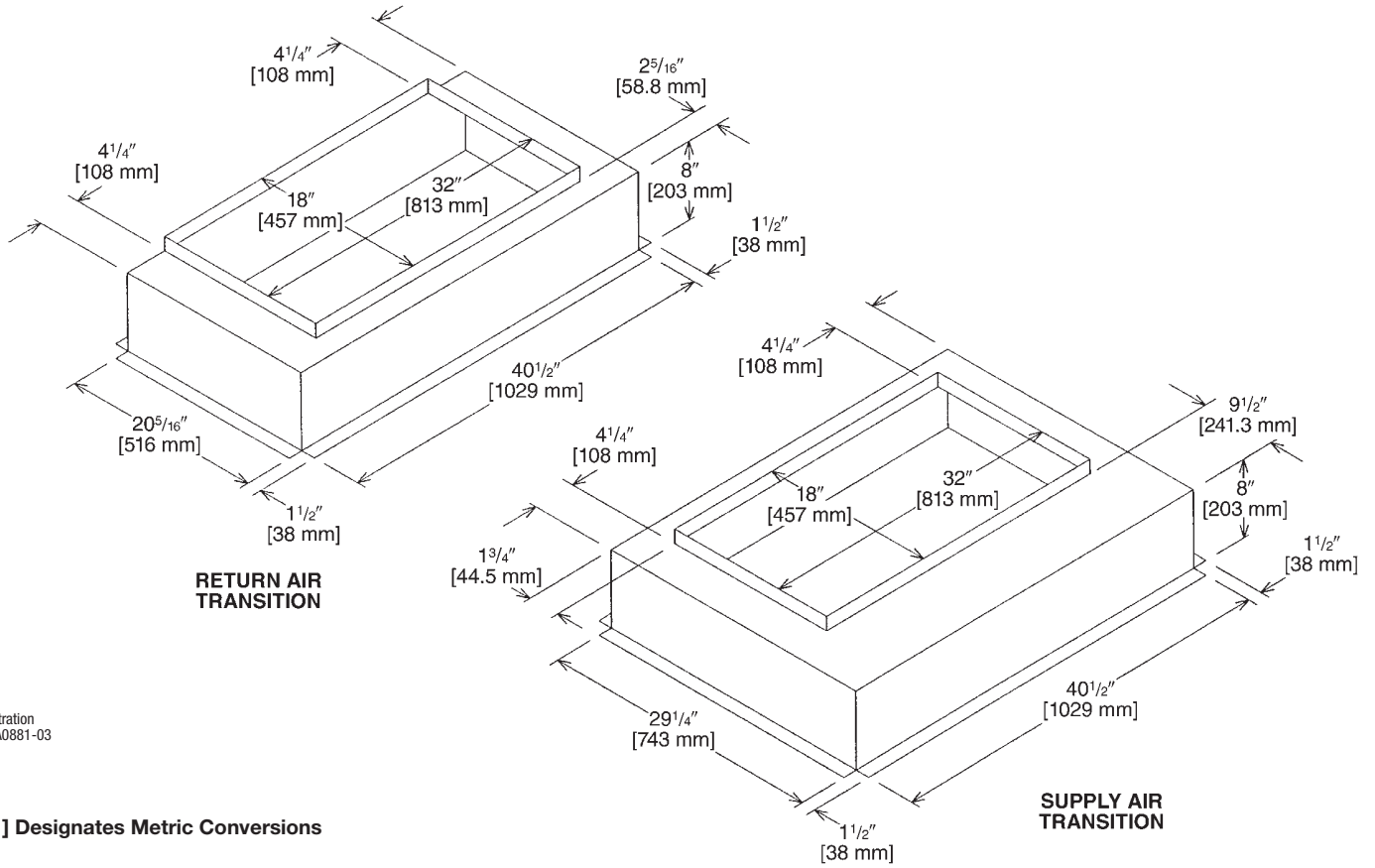

Illustration
 ST-A0881-03

[] Designates Metric Conversions

DOWNFLOW TRANSITION DRAWINGS (Cont.)

RXMC-CD04

- Used with RXRN-FA65 or RXRN-FA75 Concentric Diffusers.

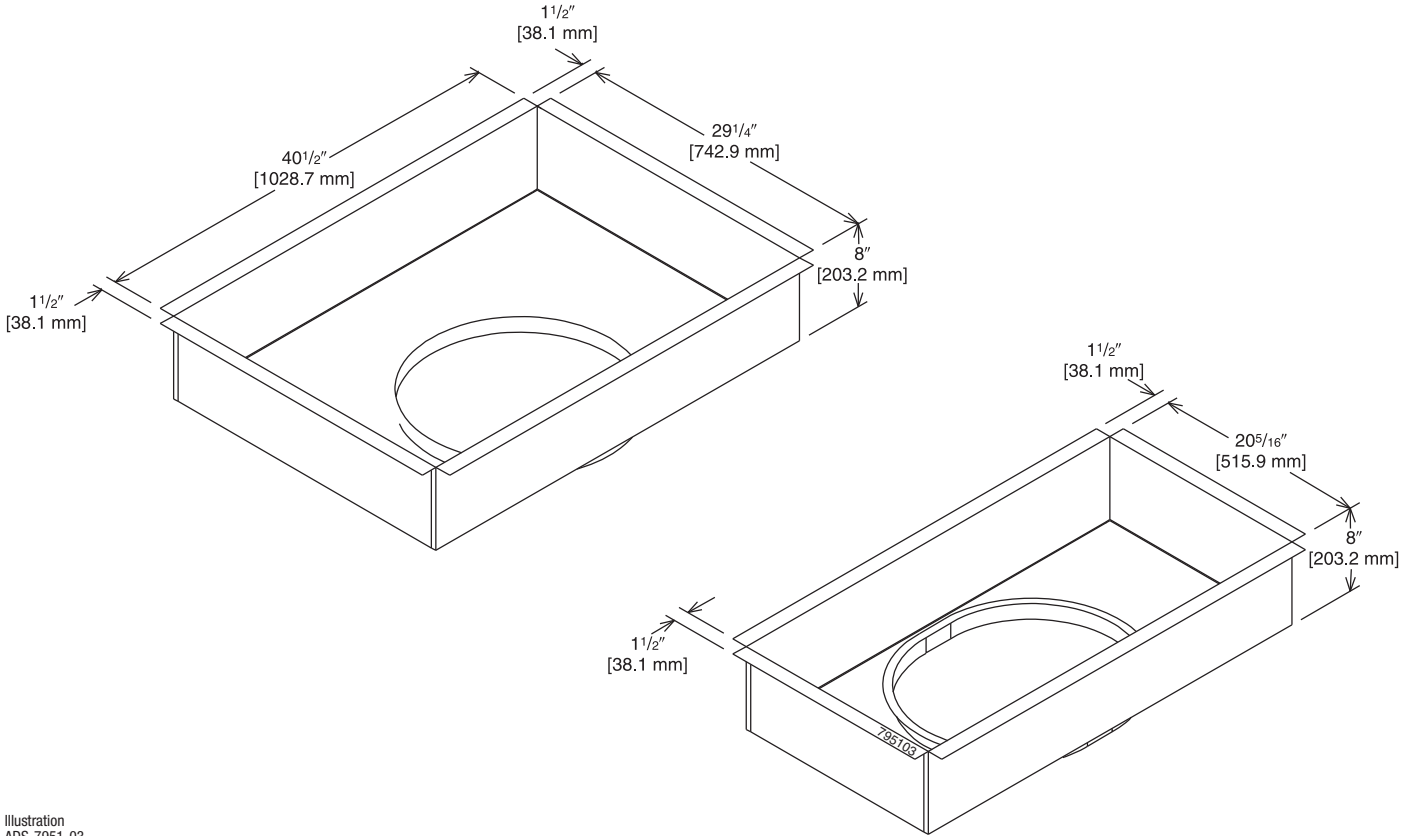

Illustration
ADS-7951-03

[] Designates Metric Conversions

CONCENTRIC DIFFUSER—STEP DOWN

RXRN-FA65 (7.5 Ton [26.4 kW] Models)

For Use With Downflow Transition (RXMC-CD04)
and 20" [508 mm] Round Supply and Return Ducts

- All aluminum diffuser with aluminum return air eggcrate.
- Built-in anti-sweat gasket.
- Molded fiberglass supports.
- Built-in hanging supports.
- Diffuser box constructed of sheetmetal insulated with 1" [25.4 mm] 1.5 lbs. [.7 kg] duct liner.

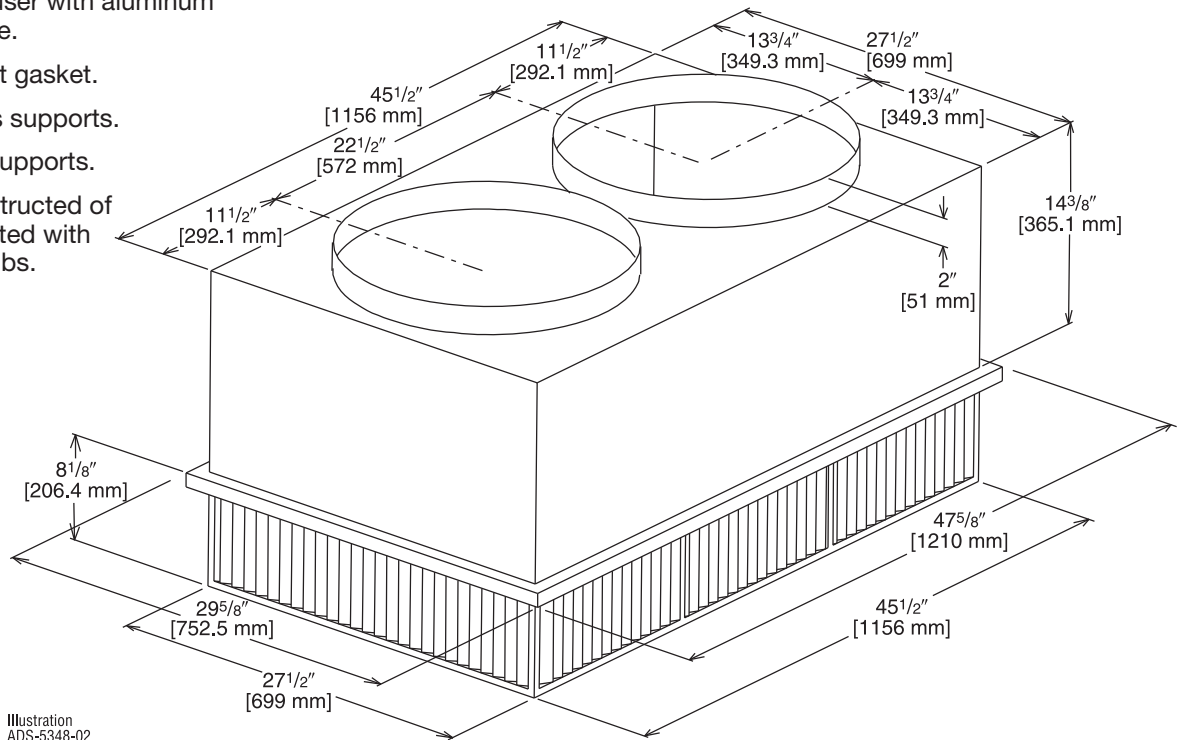

Illustration
ADS-5348-02

ENGINEERING DATA^①

Model No.	Flow Rate CFM [L/s]	Static Pressure in. w.c. [kPa]	Throw ^{② ③} Feet [m]	Neck Velocity fpm [m/s]	Noise Level ^④ (dB _A)
RXRN-FA65	2600 [1227]	0.17 [0.042]	24-29 [7.3-8.8]	669 [3.4]	20
	2800 [1321]	0.20 [0.050]	25-30 [7.6-9.1]	720 [3.7]	25
	3000 [1416]	0.25 [0.062]	27-33 [8.2-10.1]	772 [3.9]	25
	3200 [1510]	0.31 [0.077]	28-35 [8.5-10.7]	823 [4.2]	25
	3400 [1604]	0.37 [0.092]	30-37 [9.1-11.3]	874 [4.4]	30

NOTES: ① All data is based on the air diffusion council guidelines.

② Throw data is based on 75 FPM Terminal Velocities using isothermal air.

③ Throw is based on diffuser blades being directed in a straight pattern.

④ Actual noise levels may vary due to duct design and do not include transmitted unit noise.
Adequate duct attenuation must be provided to reduce sound output from the unit.

[] Designates Metric Conversions

CONCENTRIC DIFFUSER—STEP DOWN 18" x 28" [457.2 x 711.2 mm]

RXRN-AA61 (10 Ton [35.2 kW] Models)

For Use With Downflow Transition (RXMC-CE05)
and 18" x 28" [457.2 x 711.2 mm]
Supply and Return Ducts

- All aluminum diffuser with aluminum return air eggcrate.
- Built-in anti-sweat gasket.
- Molded fiberglass supports.
- Built-in hanging supports.
- Diffuser box constructed of sheetmetal insulated with 1" [25.4 mm] 1.5 lbs. [.7 kg] duct liner.
- Double deflection diffuser with the blades secured by spring steel.

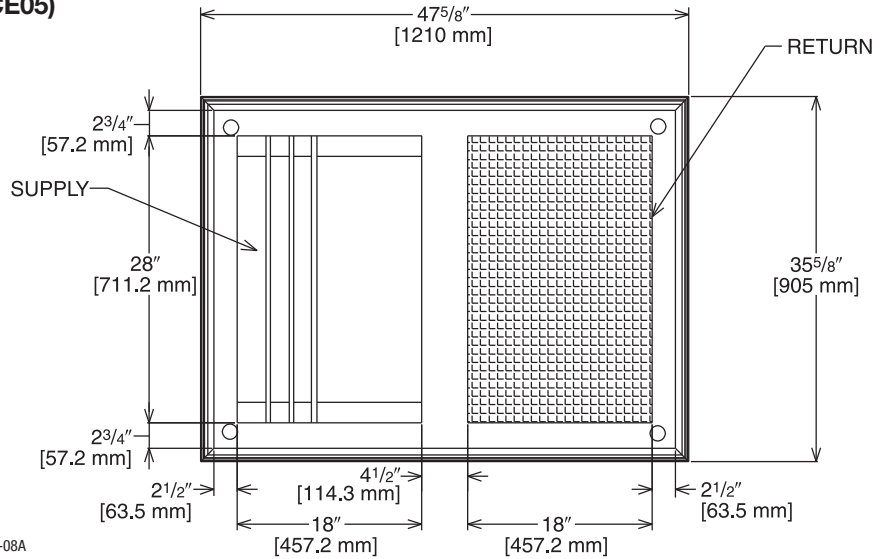

Illustration
ADS-7951-08A

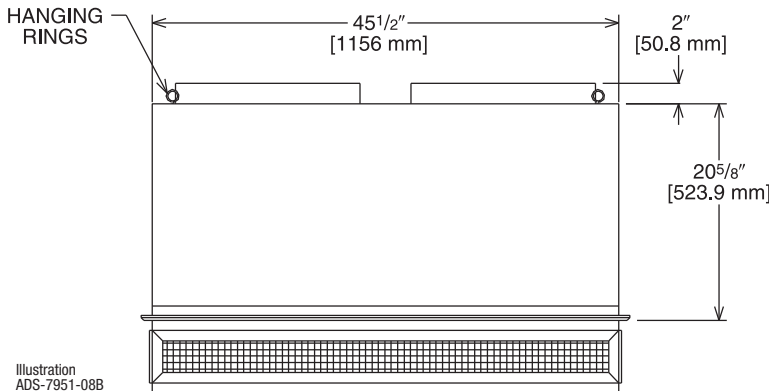

Illustration
ADS-7951-08B

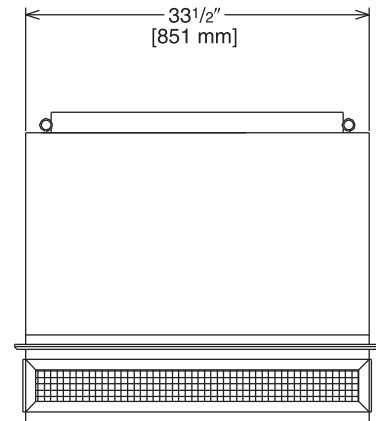

Illustration
ADS-7951-08C

ENGINEERING DATA^①

Model No.	Flow Rate CFM [L/s]	Static Pressure in w.c. [kPa]	Throw ^{② ③} Feet [m]	Neck Velocity fpm [m/s]	Noise Level ^④ (dbA)
RXRN-AA61	3600 [1699]	0.17 [0.042]	25-33 [7.6-10.1]	851 [4.3]	30
	3800 [1793]	0.18 [0.045]	27-35 [8.2-10.7]	898 [4.6]	30
	4000 [1888]	0.21 [0.052]	29-37 [8.8-11.3]	946 [4.8]	30
	4200 [1982]	0.24 [0.060]	32-40 [9.8-12.2]	993 [5.0]	30
	4400 [2076]	0.27 [0.067]	34-42 [10.4-12.8]	1040 [5.3]	30

- NOTES: ① All data is based on the air diffusion council guidelines.
 ② Throw data is based on 75 FPM Terminal Velocities using isothermal air.
 ③ Throw is based on diffuser blades being directed in a straight pattern.
 ④ Actual noise levels may vary due to duct design and do not include transmitted unit noise.
 Adequate duct attenuation must be provided to reduce sound output from the unit.

[] Designates Metric Conversions

CONCENTRIC DIFFUSER—STEP DOWN 18" x 32" [457.2 x 813 mm]

RXRN-AA66 (10 Ton [35.2 kW] Models)

For Use With Downflow Transition (RXMC-CF06)
and 18" x 32" [457.2 x 813 mm]
Supply and Return Ducts

- All aluminum diffuser with aluminum return air eggcrate.
- Built-in anti-sweat gasket.
- Molded fiberglass supports.
- Built-in hanging supports.
- Diffuser box constructed of sheetmetal insulated with 1" [25.4 mm] 1.5 lbs. [.7 kg] duct liner.
- Double deflection diffuser with the blades secured by spring steel.

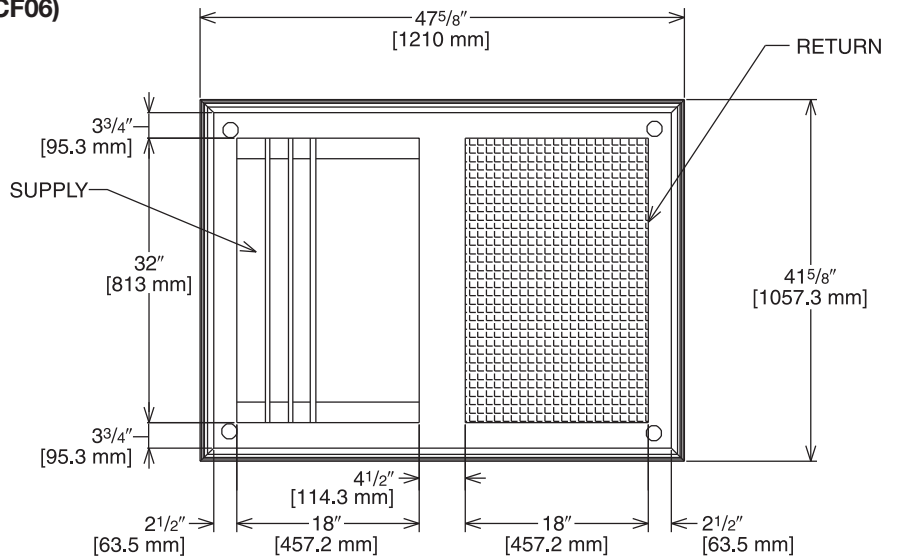

Illustration
ADS-7951-09A

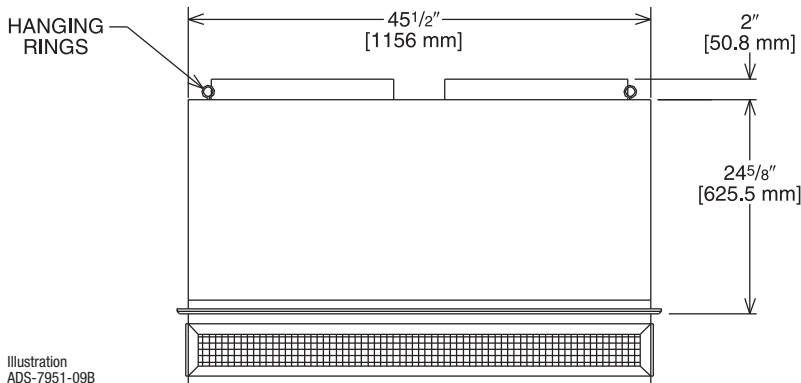

Illustration
ADS-7951-09B

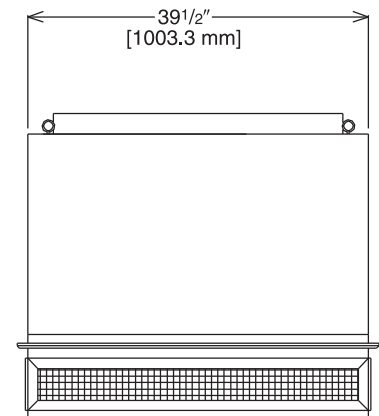

Illustration
ADS-7951-09C

ENGINEERING DATA^①

Model No.	Flow Rate CFM [L/s]	Static Pressure in w.c. [kPa]	Throw ^{② ③} Feet [m]	Neck Velocity fpm [m/s]	Noise Level ^④ (dbA)
RXRN-AA66	4600 [2171]	0.31 [0.077]	26-31 [7.9-9.4]	841 [4.3]	30
	4800 [2265]	0.32 [0.080]	27-32 [8.2-9.8]	878 [4.5]	30
	5000 [2359]	0.34 [0.085]	28-33 [8.5-10.1]	915 [4.6]	30
	5200 [2454]	0.36 [0.090]	28-34 [8.5-10.4]	951 [4.8]	30
	5400 [2548]	0.39 [0.097]	29-35 [8.8-10.7]	988 [6.0]	30

NOTES: ① All data is based on the air diffusion council guidelines.

② Throw data is based on 75 FPM Terminal Velocities using isothermal air.

③ Throw is based on diffuser blades being directed in a straight pattern.

④ Actual noise levels may vary due to duct design and do not include transmitted unit noise.
Adequate duct attenuation must be provided to reduce sound output from the unit.

[] Designates Metric Conversions

FLUSH MOUNT CONCENTRIC DIFFUSER—FLUSH

RXRN-FA75 (7.5 Ton [26.4 kW] Models)

For Use With Downflow Transition (RXMC-CD04)
and 20" [508 mm] Round Supply and Return Ducts

- All aluminum diffuser with aluminum return air eggcrate.
- Built-in anti-sweat gasket.
- Molded fiberglass supports.
- Built-in hanging supports.
- Diffuser box constructed of sheetmetal insulated with 1" [25.4 mm] 1.5 lbs. [.7 kg] duct liner.

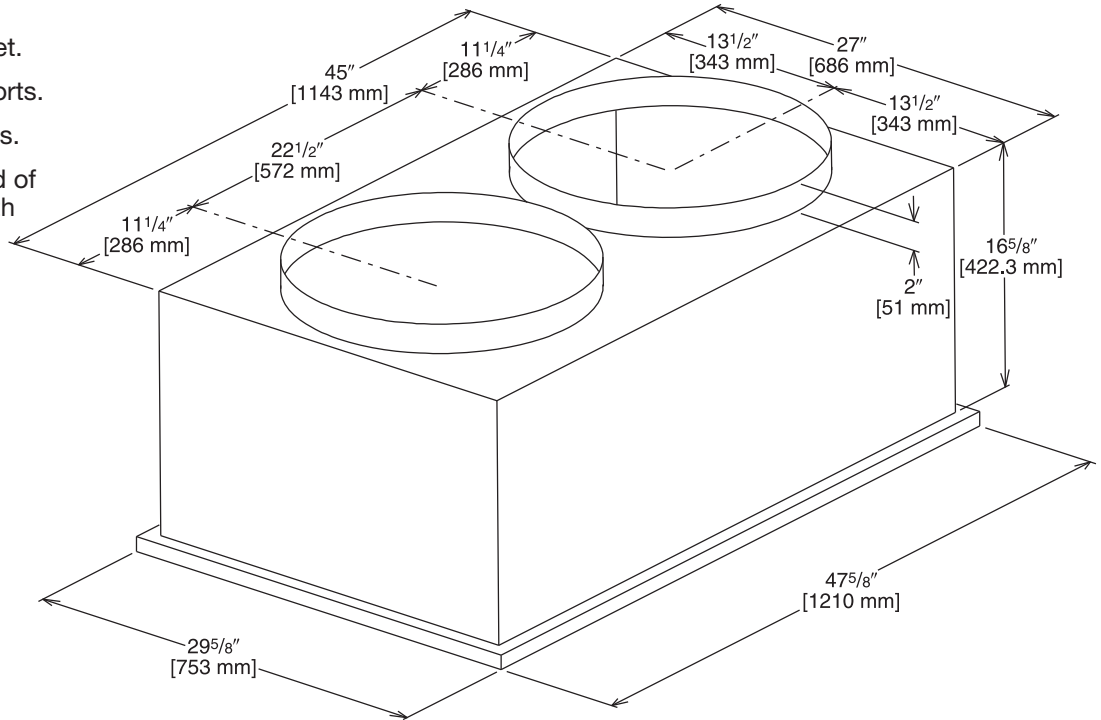

Illustration
ADS-5348-04

ENGINEERING DATA^①

Model No.	Flow Rate CFM [L/s]	Static Pressure in. w.c. [kPa]	Throw ^{② ③} Feet [m]	Neck Velocity fpm [m/s]	Noise Level ^④ (dbA)
RXRN-FA75	2600 [1227]	.17 [0.042]	19-24 [5.8-7.3]	663 [3.4]	30
	2800 [1321]	.20 [0.050]	20-28 [6.1-8.5]	714 [3.6]	35
	3000 [1416]	.25 [0.062]	21-29 [6.4-8.8]	765 [3.9]	35
	3200 [1510]	.31 [0.077]	22-29 [6.7-8.8]	816 [4.1]	40
	3400 [1604]	.37 [0.092]	22-30 [6.7-9.1]	867 [4.4]	40

- NOTES: ① All data is based on the air diffusion council guidelines.
 ② Throw data is based on 75 FPM Terminal Velocities using isothermal air.
 ③ Throw is based on diffuser blades being directed in a straight pattern.
 ④ Actual noise levels may vary due to duct design and do not include transmitted unit noise.
 Adequate duct attenuation must be provided to reduce sound output from the unit.

[] Designates Metric Conversions

CONCENTRIC DIFFUSER—FLUSH and 18" x 28" [457.2 x 711.2 mm]

RXRN-AA71 (10 Ton [35.2 kW] Models)

For Use With Downflow Transition (RXMC-CE05)
and 18" x 28" [457.2 x 711.2 mm]
Supply and Return Ducts

- All aluminum diffuser with aluminum return air eggcrate.
- Built-in anti-sweat gasket.
- Molded fiberglass supports.
- Built-in hanging supports.
- Diffuser box constructed of sheetmetal insulated with 1" [25.4 mm] 1.5 lbs. [.7 kg] duct liner.

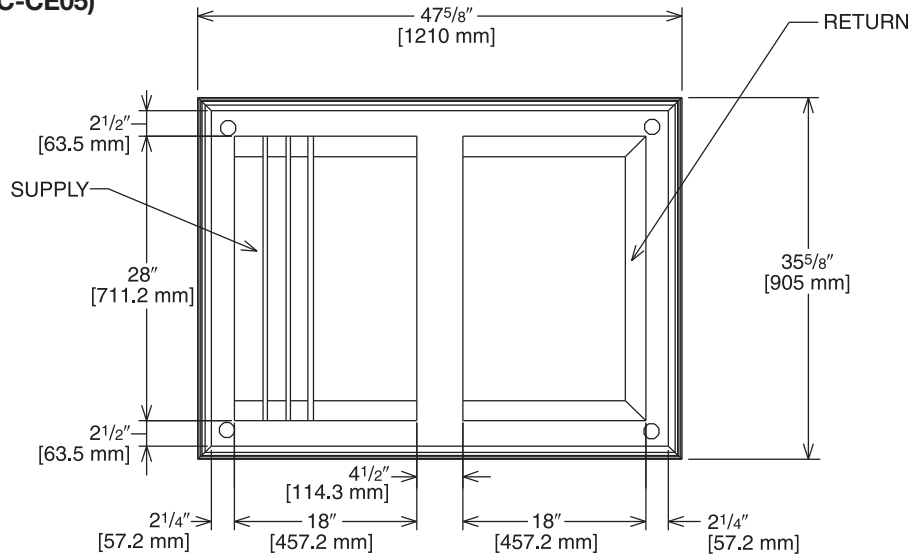

Illustration
ADS-7951-06A

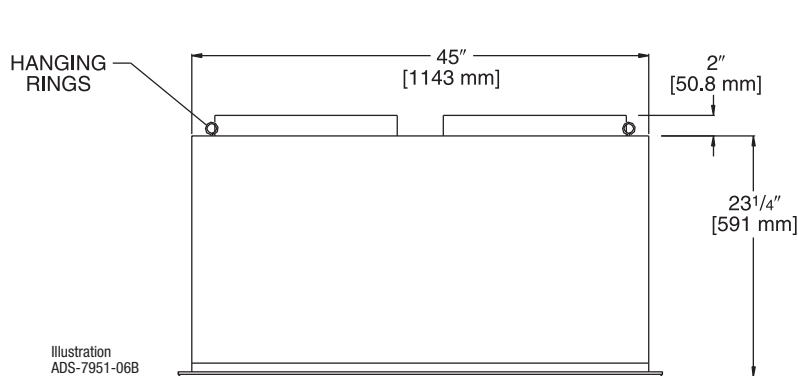

Illustration
ADS-7951-06B

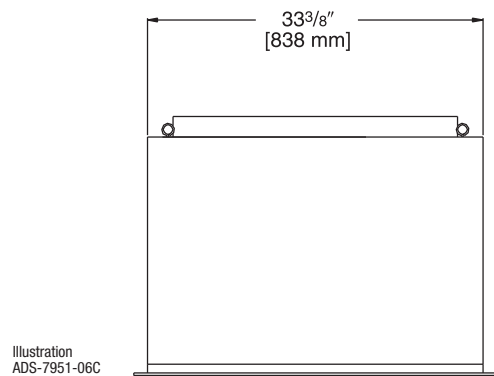

Illustration
ADS-7951-06C

ENGINEERING DATA^①

Model No.	Flow Rate CFM [L/s]	Static Pressure in w.c. [kPa]	Throw ^{② ③} Feet [m]	Neck Velocity fpm [m/s]	Noise Level ^④ (dB)
RXRN-AA71	3600 [1699]	0.17 [0.042]	22-29 [6.7-8.8]	844 [4.3]	35
	3800 [1793]	0.18 [0.045]	22-30 [6.7-9.1]	891 [4.5]	40
	4000 [1888]	0.21 [0.052]	24-33 [7.3-10.1]	938 [4.8]	40
	4200 [1982]	0.24 [0.060]	26-35 [7.9-10.7]	985 [5.0]	40
	4400 [2076]	0.27 [0.067]	28-37 [8.5-11.3]	1032 [5.2]	40

- NOTES: ① All data is based on the air diffusion council guidelines.
 ② Throw data is based on 75 FPM Terminal Velocities using isothermal air.
 ③ Throw is based on diffuser blades being directed in a straight pattern.
 ④ Actual noise levels may vary due to duct design and do not include transmitted unit noise.
 Adequate duct attenuation must be provided to reduce sound output from the unit.

[] Designates Metric Conversions

CONCENTRIC DIFFUSER—FLUSH 18" x 32" [457.2 x 813 mm]

RXRN-AA76 (10 Ton [35.2 kW] Models)

For Use With Downflow Transition (RXMC-CF06)
and 18" x 32" [457.2 x 813 mm]
Supply and Return Ducts

- All aluminum diffuser with aluminum return air eggcrate.
- Built-in anti-sweat gasket.
- Molded fiberglass supports.
- Built-in hanging supports.
- Diffuser box constructed of sheetmetal insulated with 1" [25.4 mm] 1.5 lbs. [.7 kg] duct liner.

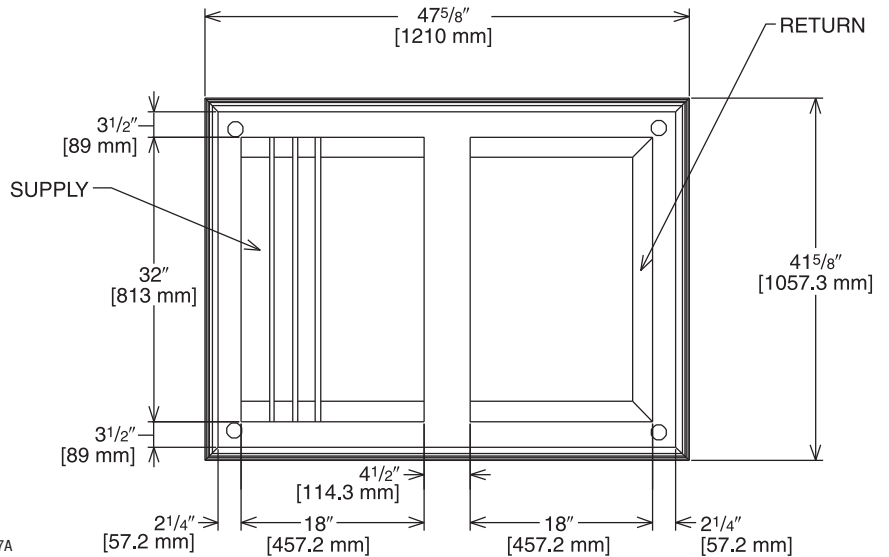

Illustration
ADS-7951-07A

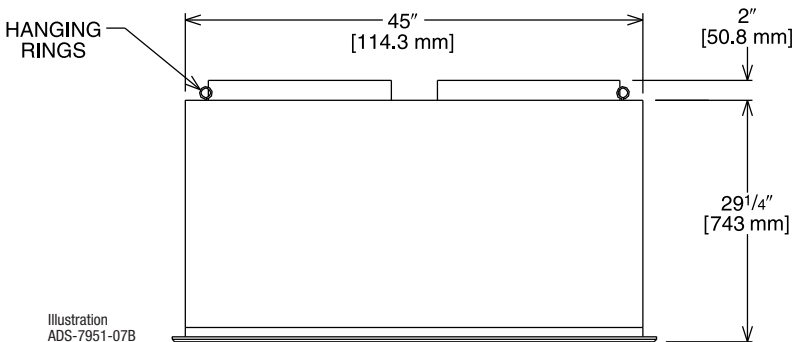

Illustration
ADS-7951-07B

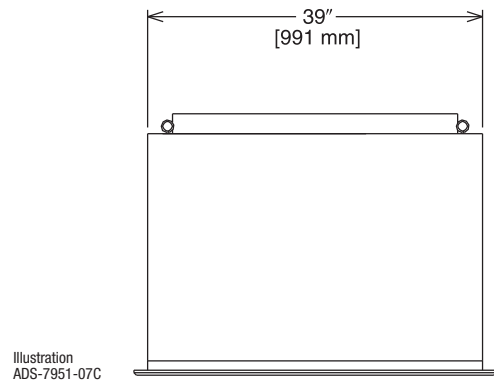

Illustration
ADS-7951-07C

ENGINEERING DATA^①

Model No.	Flow Rate CFM [L/s]	Static Pressure in w.c. [kPa]	Throw ^{② ③} Feet [m]	Neck Velocity fpm [m/s]	Noise Level ^④ (dba)
RXRN-AA76	4600 [2171]	0.31 [0.077]	25-34 [7.6-10.4]	922 [4.7]	40
	4800 [2265]	0.32 [0.080]	26-35 [7.9-10.7]	962 [4.9]	40
	5000 [2359]	0.34 [0.085]	27-36 [8.2-11.0]	1002 [5.1]	40
	5200 [2454]	0.36 [0.090]	30-39 [9.1-11.9]	1043 [5.3]	45
	5400 [2548]	0.39 [0.097]	32-41 [9.8-12.5]	1083 [5.5]	45

NOTES: ① All data is based on the air diffusion council guidelines.

② Throw data is based on 75 FPM Terminal Velocities using isothermal air.

③ Throw is based on diffuser blades being directed in a straight pattern.

④ Actual noise levels may vary due to duct design and do not include transmitted unit noise.

Adequate duct attenuation must be provided to reduce sound output from the unit.

[] Designates Metric Conversions

General

Units shall be convertible airflow. Cooling performance shall be rated in accordance with DOE and/or AHRI testing procedures. All units shall be factory assembled, internally wired, fully charged with 410A, and 100 percent run-tested before leaving the factory. Wiring internal to the unit shall be colored and numbered for simplified identification. Units shall be UL listed and labeled, classified in accordance to UL 1995/CAN/CSA No. 236-M90 for central cooling air conditioners.

Casing

Unit casing shall be constructed of zinc coated, heavy gauge, galvanized steel. Exterior surfaces shall be cleaned, phosphatized, and finished with a weather-resistant baked enamel finish. Unit's surface shall be tested 1000 hours in a salt spray test in compliance with ASTM B117. Cabinet construction shall allow for all maintenance on one side of the unit. All exposed vertical panels and top covers in the indoor air section shall be insulated with a cleanable foil faced, fire retardant permanent, odorless glass fiber material and secured with adhesive and mechanical fasteners. The base of the unit shall be insulated with foil-faced material. All insulation edges shall be either captured or sealed. The unit's base pan shall have no penetrations within the perimeter of the curb other than the raised 1-1/8" [28.58 mm] high downflow supply return openings to provide an added water integrity precaution. The base rails of the unit shall have provisions for forklift and crane lifting, with forklift capabilities on three sides of the unit.

Unit Top

The indoor top cover shall be one-piece construction, it shall not be double-hemmed and gasket-sealed.

Filters

Two inch [50.8 mm], throwaway filters shall be standard on all units.

Compressors

Units shall have direct-drive, hermetic, scroll type compressors with centrifugal type oil pumps. Motor shall be suction gas-cooled and shall have a voltage utilization range of plus or minus 10 percent of unit nameplate voltage. Internal overloads shall be provided with the scroll compressors. The compressor shall have external isolation to minimize noise.

Refrigerant Circuits

Refrigerant circuit shall have a TXV control expansion device. External service pressure ports, shall be factory-installed as standard.

Evaporator And Condenser Coils

Internally finned, 3/8" [9.53 mm] copper tubes mechanically bonded to a configured aluminum plate fin shall be standard. Coils shall be leak tested at the factory to ensure pressure integrity. The evaporator coil and condenser coil shall be leak tested to 250 psig and pressure tested to 550 psig. A sloped condensate drain pan shall be standard.

Outdoor Fans

The outdoor fans shall be direct-drive statically and dynamically balanced, draw-through in the vertical discharge position. The fan motor shall be permanently lubricated and shall have built-in thermal overload protection.

Indoor Fans

All 3-phase units offer belt drive, FC centrifugal fans with adjustable motor sheaves. All motors shall be thermally protected. All indoor fan motors meet the U.S. Energy Policy Act of 1992 (EPACT).

Controls

Unit shall be completely factory wired with necessary controls and contactor pressure lugs or terminal block for power wiring. Units shall provide an external location for mounting a fused disconnect device.

24-volt electromechanical control circuit shall include control transformer and contactor pressure lugs for power wiring. Unit shall have single point power entry as standard.

Accessories/Option

Roof Curb—The roof curb shall be designed to mate with the unit's downflow supply and return openings and provide support and a watertight installation when installed properly. The roof curb design shall allow field-fabricated rectangular supply/return ductwork to be connected directly to the curb. Curb design shall comply with NRCA requirements. Curbs shall be shipped knocked down for tool-less field assembly and shall include wood nailer strips.

Economizer—This accessory shall be either field or factory-installed and is available with barometric relief standard. The assembly includes direct drive gear driver, fully modulating 0-100 percent motor and dampers, minimum position setting, mixed air sensor, wiring harness with plug, and single enthalpy control. Optional differential enthalpy control shall be field-installed. The factory-installed economizer arrives ready for operation.

Remote Potentiometer—Field installed, the minimum position setting of economizer shall be adjusted with this accessory.

Motorized Outside Air Dampers

Field-installed manually set outdoor air dampers shall provide up to 50 percent outside air. Once set, outdoor air dampers shall open to set position when indoor fan starts. The damper shall close to the full closed position when indoor fan shuts down.

Manual Outside Air Damper—Factory or field-installed rain hood and screen shall provide up to 50 percent outside air.

Oversized Motors—Factory installed belt drive oversized motors shall be available for high static applications.

Powered Exhaust—The field installed powered exhaust, available for all units, shall provide exhaust of return air, when using an economizer, to maintain better building pressurization.

[] Designates Metric Conversions



Through the Base Electrical Access—An electrical service entrance shall be factory provided allowing electrical access for both, control and main power connection inside the curb and through the base of the unit.

Unpowered Convenience Outlet—This factory-installed option is a GFCI, 120v/15amp, 2 plug, and convenience outlet, unpowered. When the convenience outlet is powered, a service receptacle disconnect will be available. The convenience outlet is powered from the line side of the disconnect or circuit breaker, and therefore will not be affected by the position of the disconnect or circuit breaker. This option can only be ordered with the Disconnect Switch.

Freeze/Clogged Filter Switches—This factory or field-installed option allows for individual fan failure or dirty filter protection. If indoor coil gets too cold due to low airflow, compressor operation will be temporarily interrupted.

Enthalpy Control—Single Enthalpy Control shall be standard for all economizers. Enthalpy control offers a higher level of comfort control, along with energy savings potential, than the standard dry bulb control. This is due to the additional wet bulb sensing capability.

High Pressure Cutout—High pressure cutout shall be standard on all models. All scroll compressors shall include Internal Pressure Relief as standard.

Low Pressure/Loss of Charge—Low pressure switch shall be standard on all models.

Hinged Access Doors—Stainless steel metal hinges and 1/4 turn fasteners are standard on the Filter/Electrical Access Door, Heat Exchanger Door and Blower Door.

Differential Enthalpy—Adds on to the standard single control with other enthalpy sensors that compare total heat content of the indoor air and outdoor air to determine the most efficient air source. This control option offers the highest level of comfort control, plus energy efficiency available.

Low Ambient Cooling—Electromechanical models have cooling capabilities to 40°F as built, or to 0°F by adding the optional low ambient (froststat) control.



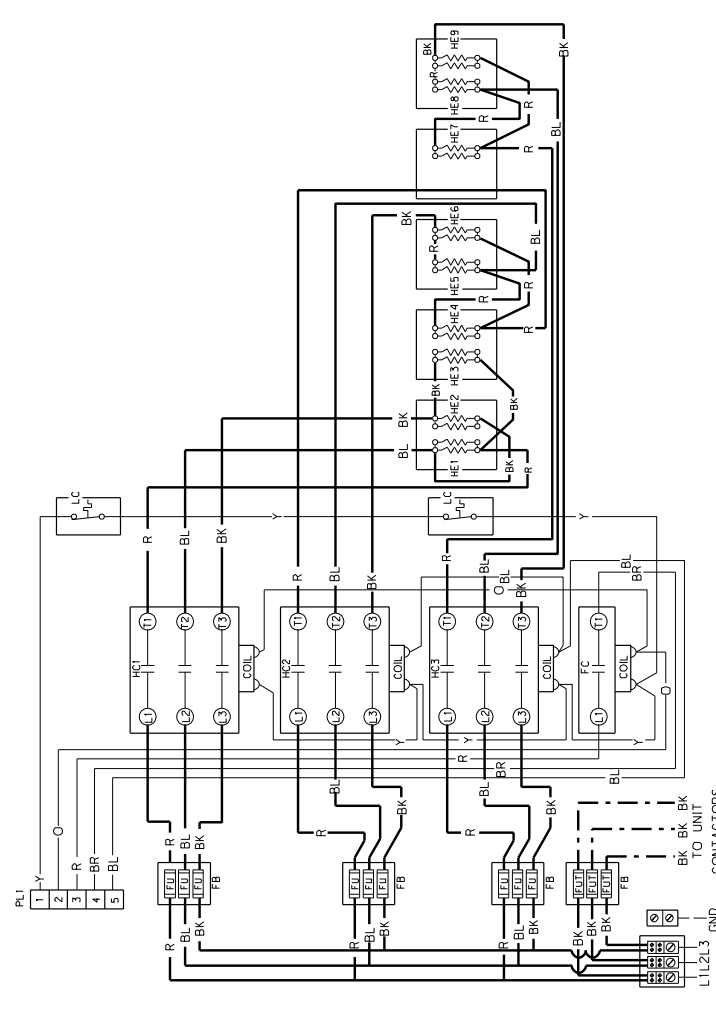
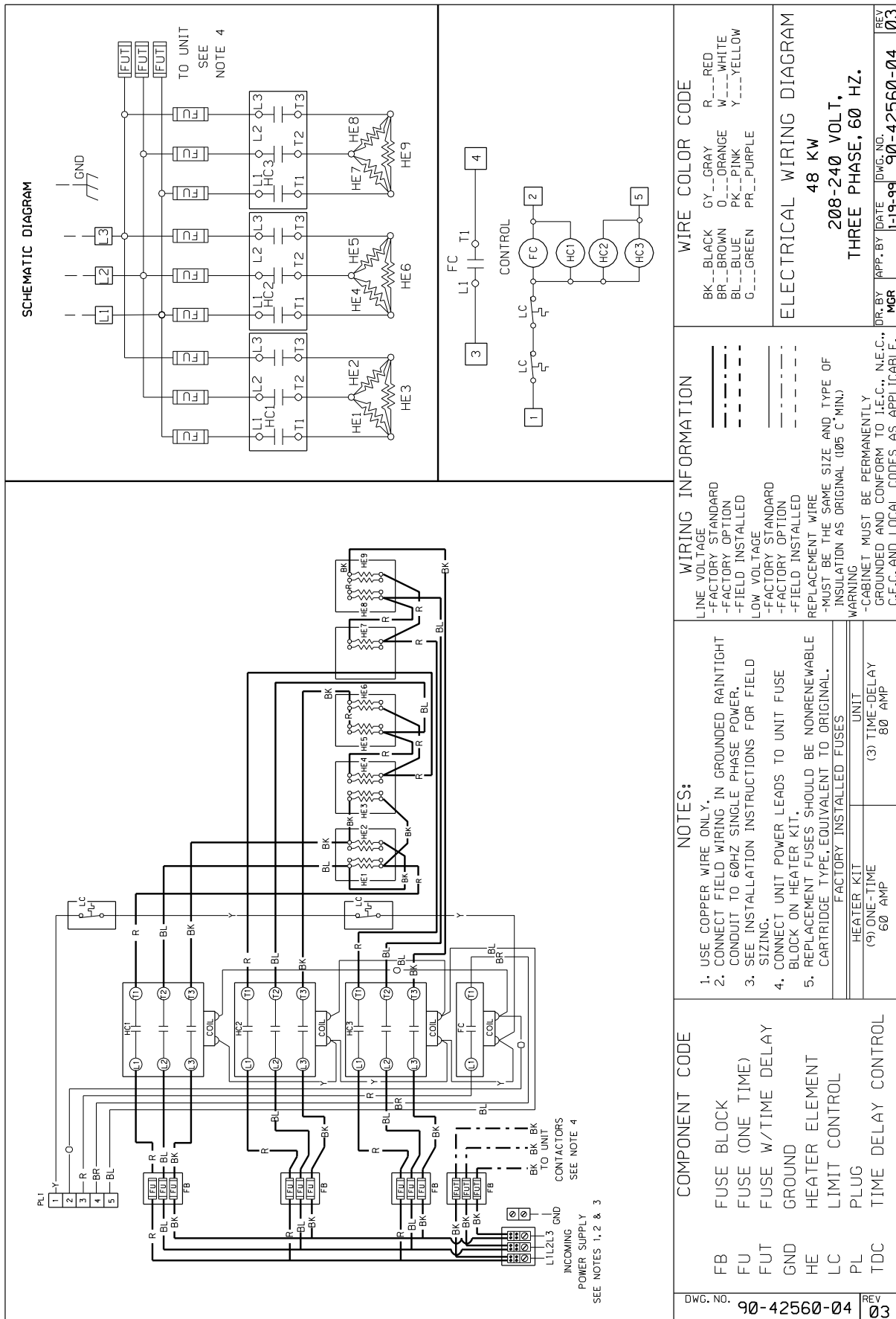

COMPONENT CODE

FB	FUSE BLOCK
FU	FUSE (ONE TIME)
FUT	FUSE W/TIME DELAY
GND	GROUND
HE	HEATER ELEMENT
LC	LIMIT CONTROL
PL	PLUG
TDC	TIME DELAY CONTROL

NOTES:

- USE COPPER WIRE ONLY.
- CONNECT FIELD WIRING IN GROUNDED RAINTIGHT CONDUIT TO 60HZ SINGLE PHASE POWER.
- SEE INSTALLATION INSTRUCTIONS FOR FIELD SIZING.
- CONNECT UNIT POWER LEADS TO UNIT FUSE BLOCK ON HEATER KIT.
- REPLACEMENT FUSES SHOULD BE NONRENEWABLE CARTRIDGE TYPE, EQUIVALENT TO ORIGINAL. FACTORY INSTALLED FUSES

WIRING INFORMATION

LINE VOLTAGE
-FACTORY STANDARD
-FACTORY OPTION
-FIELD INSTALLED
LOW VOLTAGE
-FACTORY STANDARD
-FACTORY OPTION
-FIELD INSTALLED
REPLACEMENT WIRE
-MUST BE THE SAME SIZE AND TYPE OF INSULATION AS ORIGINAL (105 C-MIN.)
WARNING
-CABINET MUST BE PERMANENTLY GROUNDED AND CONFORM TO I.E.C., N.E.C., C.E.C. AND LOCAL CODES AS APPLICABLE.

WIRE COLOR CODE

BK...BLACK GY...GRAY R...RED
BR...BROWN O...ORANGE W...WHITE
BL...BLUE PK...PINK Y...YELLOW
G...GREEN PR...PURPLE

ELECTRICAL WIRING DIAGRAM

48 KW
208-240 VOLT.
THREE PHASE, 60 HZ.

DR. BY [] APP. BY [] DATE [] DWG. NO. 90-42560-04 REV 03

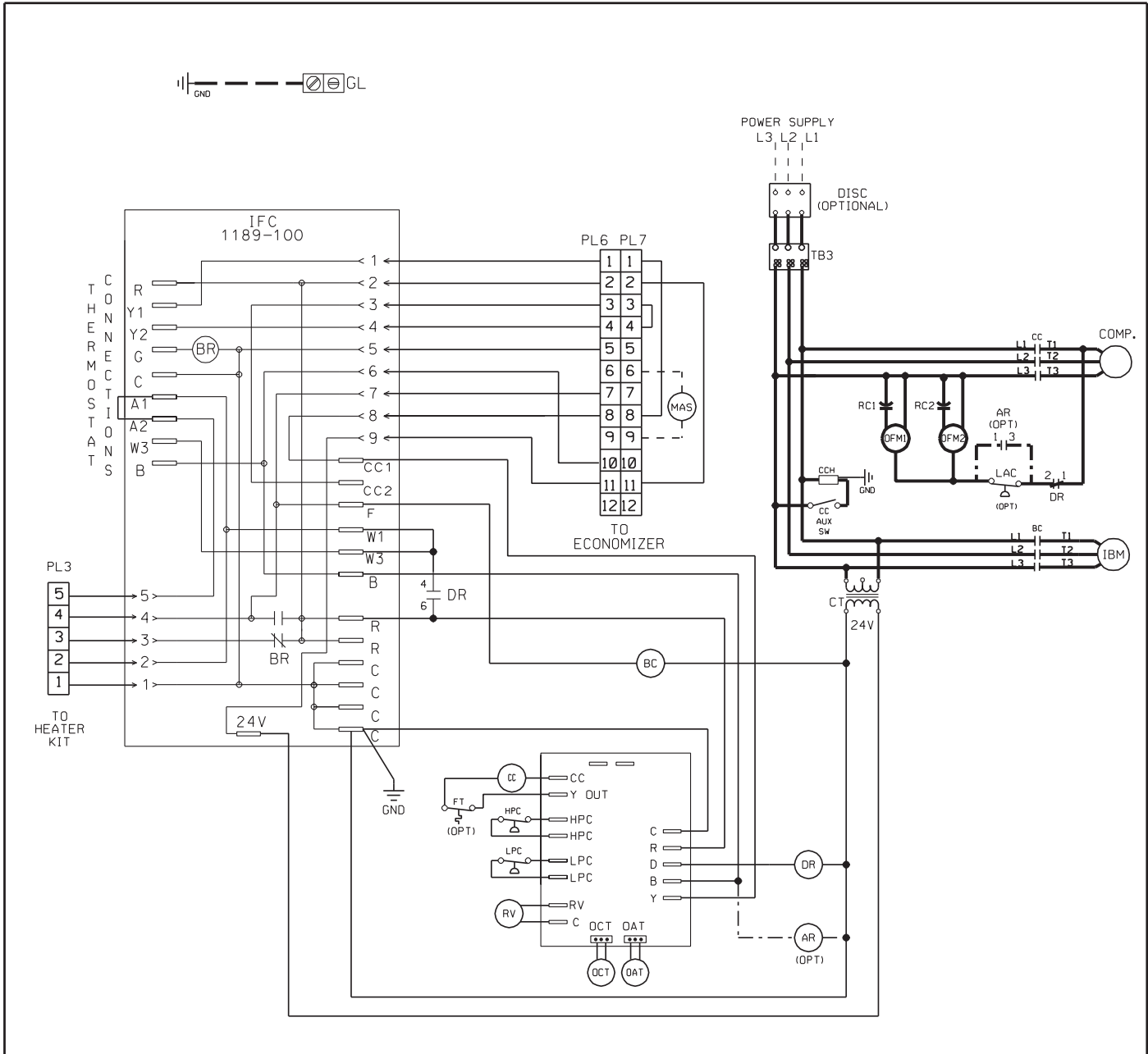

COMPONENT CODE

AUX SW	AUXILIARY SWITCH	MAS	MIXED AIR SENSOR
BC	BLOWER MOTOR CONTACTOR	OFM	OUTDOOR FAN MOTOR
BR	BLOWER RELAY	OPT	OPTIONAL
CC	COMPRESSOR CONTACTOR	PL	PLUG
CCH	CRANKCASE HEATER	RC	RUN CAPACITOR
COMP	COMPRESSOR	TB	TERMINAL BLOCK
CT	CONTROL TRANSFORMER		
FT	FREEZE STAT		
GL	GROUND LUG		
GND	GROUND		
HPC	HIGH PRESSURE CONTROL		
IBM	INDOOR BLOWER MOTOR		
IFC	INTEGRATED FURNACE CONTROL		
LAC	LOW AMBIENT CONTROL		
LPC	LOW PRESSURE CONTROL		

WIRING INFORMATION

LINE VOLTAGE
 -FACTORY STANDARD —————
 -FACTORY OPTION - - - - -
 -FIELD INSTALLED - - - - -

LOW VOLTAGE
 -FACTORY STANDARD —————
 -FACTORY OPTION - - - - -
 -FIELD INSTALLED - - - - -

REPLACEMENT WIRE
 -MUST BE THE SAME SIZE AND TYPE OF INSULATION AS ORIGINAL (105° C MIN.)

WARNING
 -CABINET MUST BE PERMANENTLY GROUNDED AND CONFORM TO I.E.C., N.E.C., C.E.C., AND LOCAL CODES AS APPLICABLE.

WIRE COLOR CODE

BK	BLACK	O	ORANGE
BR	BROWN	PR	PURPLE
BL	BLUE	R	RED
G	GREEN	W	WHITE
GY	GRAY	Y	YELLOW

WIRING SCHEMATIC

7-1/2 & 10 TON PACKAGED HEAT PUMP
 208-230/460/575V 3 PH, 60 HZ
 380-415V 3 PH, 50 HZ.

DR. BY	APP. BY	DATE	DWG. NO.	REV
JRJ		02-10-09	90-23595-17	04

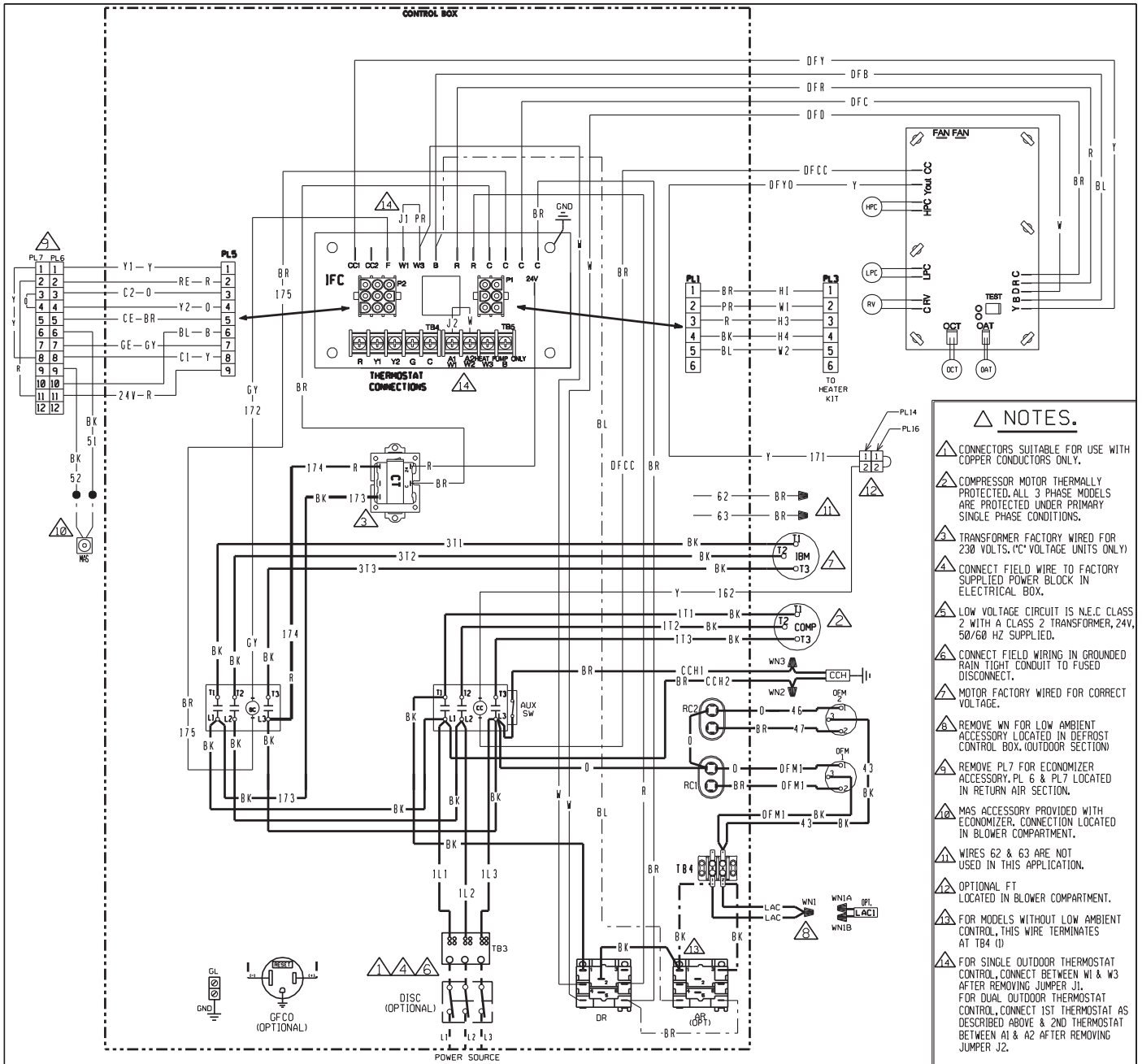

- NOTES.**
1. CONNECTORS SUITABLE FOR USE WITH COPPER CONDUCTORS ONLY.
 2. COMPRESSOR MOTOR THERMALLY PROTECTED, ALL 3 PHASE MODELS ARE PROTECTED UNDER PRIMARY SINGLE PHASE CONDITIONS.
 3. TRANSFORMER FACTORY WIRED FOR 230 VOLTS. ('C' VOLTAGE UNITS ONLY)
 4. CONNECT FIELD WIRE TO FACTORY SUPPLIED POWER BLOCK IN ELECTRICAL BOX.
 5. LOW VOLTAGE CIRCUIT IS N.E.C CLASS 2 WITH A CLASS 2 TRANSFORMER, 24V, 50/60 HZ SUPPLIED.
 6. CONNECT FIELD WIRING IN GROUNDED RAIN TIGHT CONDUIT TO FUSED DISCONNECT.
 7. MOTOR FACTORY WIRED FOR CORRECT VOLTAGE.
 8. REMOVE WN FOR LOW AMBIENT ACCESSORY LOCATED IN DEFROST CONTROL BOX. (OUTDOOR SECTION)
 9. REMOVE PL7 FOR ECONOMIZER ACCESSORY. PL 6 & PL7 LOCATED IN RETURN AIR SECTION.
 10. MAS ACCESSORY PROVIDED WITH ECONOMIZER. CONNECTION LOCATED IN BLOWER COMPARTMENT.
 11. WIRES 62 & 63 ARE NOT USED IN THIS APPLICATION.
 12. OPTIONAL FT LOCATED IN BLOWER COMPARTMENT.
 13. FOR MODELS WITHOUT LOW AMBIENT CONTROL, THIS WIRE TERMINATES AT TB4 (I)
 14. FOR SINGLE OUTDOOR THERMOSTAT CONTROL, CONNECT BETWEEN W1 & W3 AFTER REMOVING JUMPER J1. FOR DUAL OUTDOOR THERMOSTAT CONTROL, CONNECT 1ST THERMOSTAT AS DESCRIBED ABOVE & 2ND THERMOSTAT BETWEEN A1 & A2 AFTER REMOVING JUMPER J2.

COMPONENT CODE	WIRING INFORMATION	WIRE COLOR CODE
AR AUXILIARY RELAY	LINE VOLTAGE	BK BLACK
BC BLOWER CONTACTOR	-FACTORY STANDARD	BR BROWN
CC COMPRESSOR CONTACTOR	-FACTORY OPTION	BL BLUE
CCH CRANKCASE HEATER	-FIELD INSTALLED	G GREEN
COMP COMPRESSOR	LOW VOLTAGE	GY GRAY
CT CONTROL TRANSFORMER	-FACTORY STANDARD	O ORANGE
DISC DISCONNECT SWITCH	-FACTORY OPTION	PR PURPLE
DR DEFROST RELAY	-FIELD INSTALLED	R RED
EHR ELECTRIC HEAT RELAY	REPLACEMENT WIRE	W WHITE
FT FREEZE STAT	-MUST BE THE SAME SIZE AND TYPE OF INSULATION AS ORIGINAL (105° C MIN.)	Y YELLOW
GFCD GROUND FAULT CONVENIENCE OUTLET	WARNING	
GL GROUND LUG	-CABINET MUST BE PERMANENTLY GROUNDED AND CONFORM TO I.E.C., N.E.C., C.E.C., AND LOCAL CODES AS APPLICABLE.	
GND GROUND		
HPC HIGH PRESSURE CONTROL		
IHM INDOOR BLOWER MOTOR BELT DRIVE		
IFC INTEGRATED FURNACE CONTROL		
LAC LOW AMBIENT COOLING CONTROL		
LPC LOW PRESSURE CONTROL		
MAS MIX AIR SENSOR		
OFM OUTDOOR FAN MOTOR		
PL PLUG		
RC RUN CAPACITOR		
TB TERMINAL BLOCK		
WN WIRE NUT		

WIRING DIAGRAM

7-1/2 & 10 TON PACKAGED HEAT PUMP
208-230/460/575V 3 PH, 60 HZ.
380-415V 3 PH, 50 HZ.

DR. BY	APP. BY	DATE	DWG. NO.	REV
JRJ		1-15-09	90-23595-16	04

BEFORE PURCHASING THIS APPLIANCE, READ IMPORTANT ENERGY COST AND EFFICIENCY INFORMATION AVAILABLE FROM YOUR RETAILER.

GENERAL TERMS OF LIMITED WARRANTY*

Rheem will furnish a replacement for any part of this product which fails in normal use and service within the applicable periods stated, in accordance with the terms of the limited warranty.

***For complete details of the Limited and Conditional Warranties, including applicable terms and conditions, contact your local contractor or the Manufacturer for a copy of the product warranty certificate.**

Compressor

3 Phase, Commercial Applications.....Five (5) Years

Parts

3 Phase, Commercial Applications.....One (1) Year



The new degree of comfort.™

In keeping with its policy of continuous progress and product improvement, Rheem reserves the right to make changes without notice.

Rheem Heating, Cooling & Water Heating • P.O. Box 17010
Fort Smith, Arkansas 72917 • www.rheem.com

Rheem Canada Ltd./Ltée • 125 Edgeware Road, Unit 1
Brampton, Ontario • L6Y 0P5



INTEGRATED AIR & WATER