

INSTALLATION INSTRUCTIONS

RHGM COMMERCIAL AIR HANDLERS

NOMINAL 7.5 AND 10 TON AIR CONDITIONING FEATURING EARTH-FRIENDLY R-410A REFRIGERANT



UL listing and CSA certification on some models is in process. Contact your distributor for available models.



! Recognize this symbol as an indication of Important Safety Information!

DO NOT DESTROY
PLEASE READ CAREFULLY AND KEEP IN A SAFE PLACE FOR FUTURE REFERENCE.

! WARNING

THESE INSTRUCTIONS ARE INTENDED AS AN AID TO QUALIFIED, LICENSED SERVICE PERSONNEL FOR PROPER INSTALLATION, ADJUSTMENT AND OPERATION OF THIS UNIT. READ THESE INSTRUCTIONS THOROUGHLY BEFORE ATTEMPTING INSTALLATION OR OPERATION. FAILURE TO FOLLOW THESE INSTRUCTIONS MAY RESULT IN IMPROPER INSTALLATION, ADJUSTMENT, SERVICE OR MAINTENANCE POSSIBLY RESULTING IN FIRE, ELECTRICAL SHOCK, PROPERTY DAMAGE, PERSONAL INJURY OR DEATH.

INDEX

Introduction	3	Location	11
Checking Product Received	3	Installation	11
Standard Unit Features	3	Piping	
Unit Dimensions	4	Refrigerant	11
Physical Data Table	5	Drain	12
Drive Package Data	5-7	Motor, Sheave & Belts	13
Low Voltage Connection	9	Pre-Start Check List	13
Branch Circuit Conductor Data	9	Operating Instructions	14
Field Installed Mixing Box Accessory	10	Service & Maintenance	14
Inspection	11	Lubrication	14

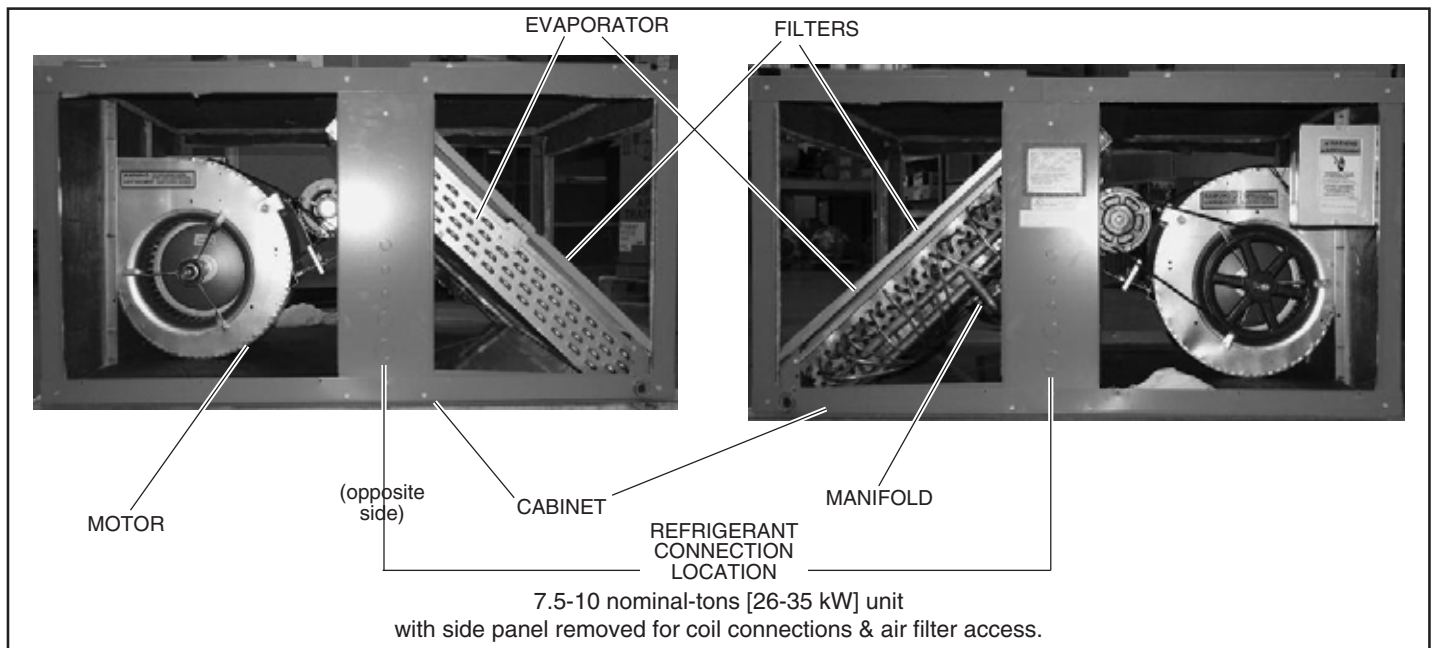
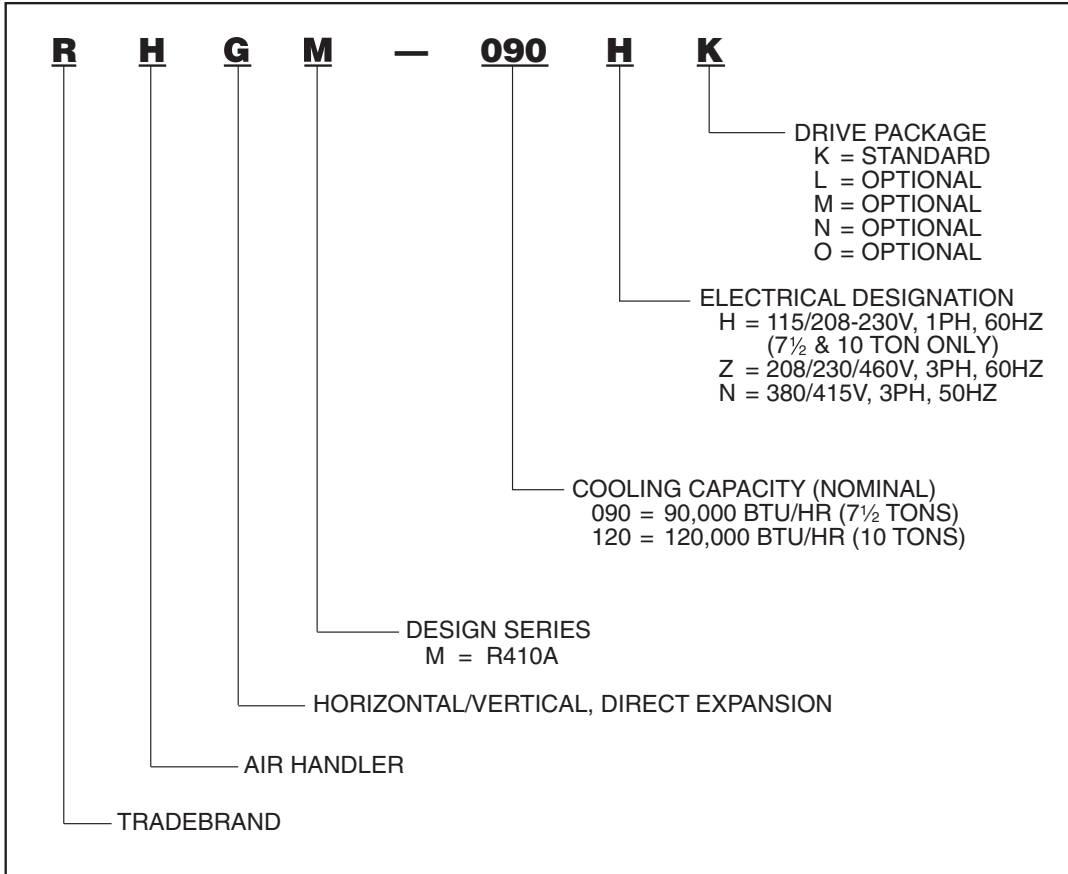

INTRODUCTION

 Recognize this symbol as an indication of Important Safety Information!

⚠ WARNING

PROPOSITION 65: THIS APPLIANCE CONTAINS FIBER-GLASS INSULATION. RESPIRABLE PARTICLES OF FIBER-GLASS ARE KNOWN TO THE STATE OF CALIFORNIA TO CAUSE CANCER.

⚠ WARNING

THE MANUFACTURER'S WARRANTY DOES NOT COVER ANY DAMAGE OR DEFECT TO THE AIR HANDLER CAUSED BY THE ATTACHMENT OR USE OF ANY COMPONENTS, ACCESSORIES OR DEVICES (OTHER THAN THOSE AUTHORIZED BY THE MANUFACTURER) INTO, ONTO OR IN CONJUNCTION WITH THE AIR HANDLER. YOU SHOULD BE AWARE THAT THE USE OF UNAUTHORIZED COMPONENTS, ACCESSORIES OR DEVICES MAY ADVERSELY AFFECT THE OPERATION OF THE AIR HANDLER AND MAY ALSO ENDANGER LIFE AND PROPERTY. THE MANUFACTURER DISCLAIMS ANY RESPONSIBILITY FOR SUCH LOSS OR INJURY RESULTING FROM THE USE OF SUCH UNAUTHORIZED COMPONENTS, ACCESSORIES OR DEVICES.

This booklet contains the installation and operating instructions for your air handler. There are a few precautions that should be taken to derive maximum satisfaction from it. Improper installation can result in unsatisfactory operation or dangerous conditions.

Read this booklet and any instructions packaged with separate equipment required to make up the system prior to installation. Give this booklet to the owner and explain its provisions. The owner should retain this booklet for future reference.

CHECKING PRODUCT RECEIVED

Upon receiving the unit, inspect it for any damage from shipment. Claims for damage, either shipping or concealed, should be filed immediately with the shipping company. Check the unit model number and electrical characteristics to determine if they are correct.

STANDARD UNIT FEATURES

HORIZONTAL OR VERTICAL—All models are designed for either application and can be installed in either position as supplied from the factory.

MANIFOLD—All models are furnished with dual circuit manifolds for dual condensing unit application. The circuitry is so arranged to provide full face coil operation from each unit. Fittings are provided with each unit for single condensing unit application. The fittings may be installed for either right or left hand tubing connections.

DRAIN PAN (not visible)—The zinc coated steel drain pan is designed to trap condensate in either vertical or horizontal installations. All pans are insulated with fiberglass insulation between the bottom of the pan and the unit and may be connected for either right or left hand drains. If unit is to be installed over a finished ceiling and in an unconditioned space, it is recommended an auxiliary drain pan be placed under the entire unit.

UNIT DIMENSIONS 7.5 AND 10 NOMINAL TONS

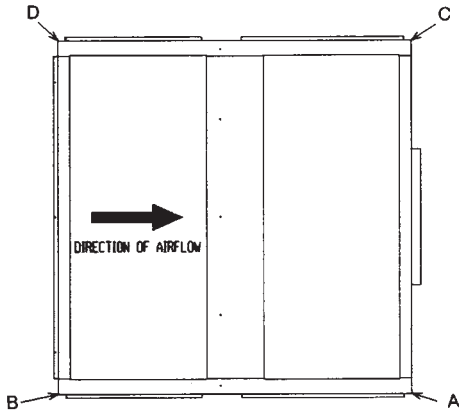

MODEL	CORNER WEIGHTS, LBS [kg]				TOTAL WEIGHT
	A	B	C	D	
7.5 TON [26 kW]	98 [44]	86 [40]	97 [44]	84 [38]	365 [166]
10 TON [35 kW]	100 [45]	88 [40]	97 [44]	87 [40]	372 [169]

RETURN AIR OPENINGS = 47% WIDTH x 19% HEIGHT

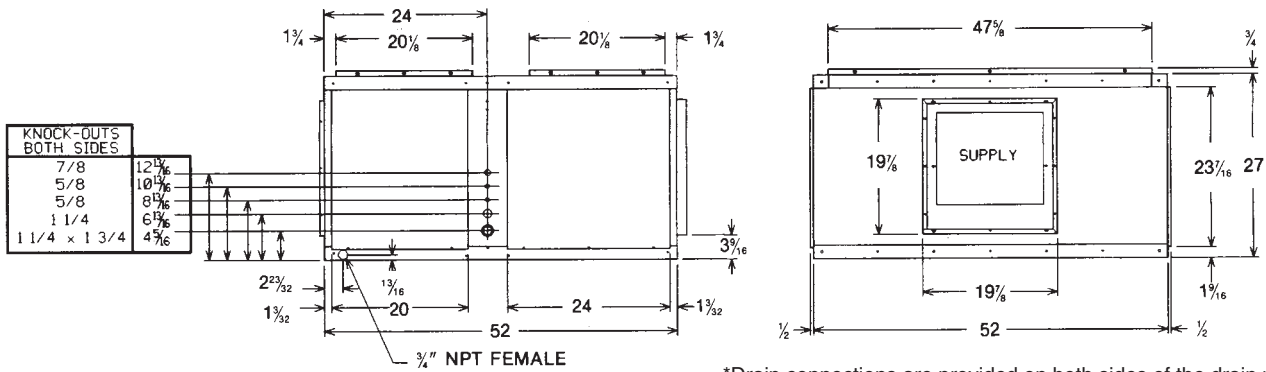

*Drain connections are provided on both sides of the drain pan. The drain can be connected to either side of the drain pan, but not both. The drain must be trapped.

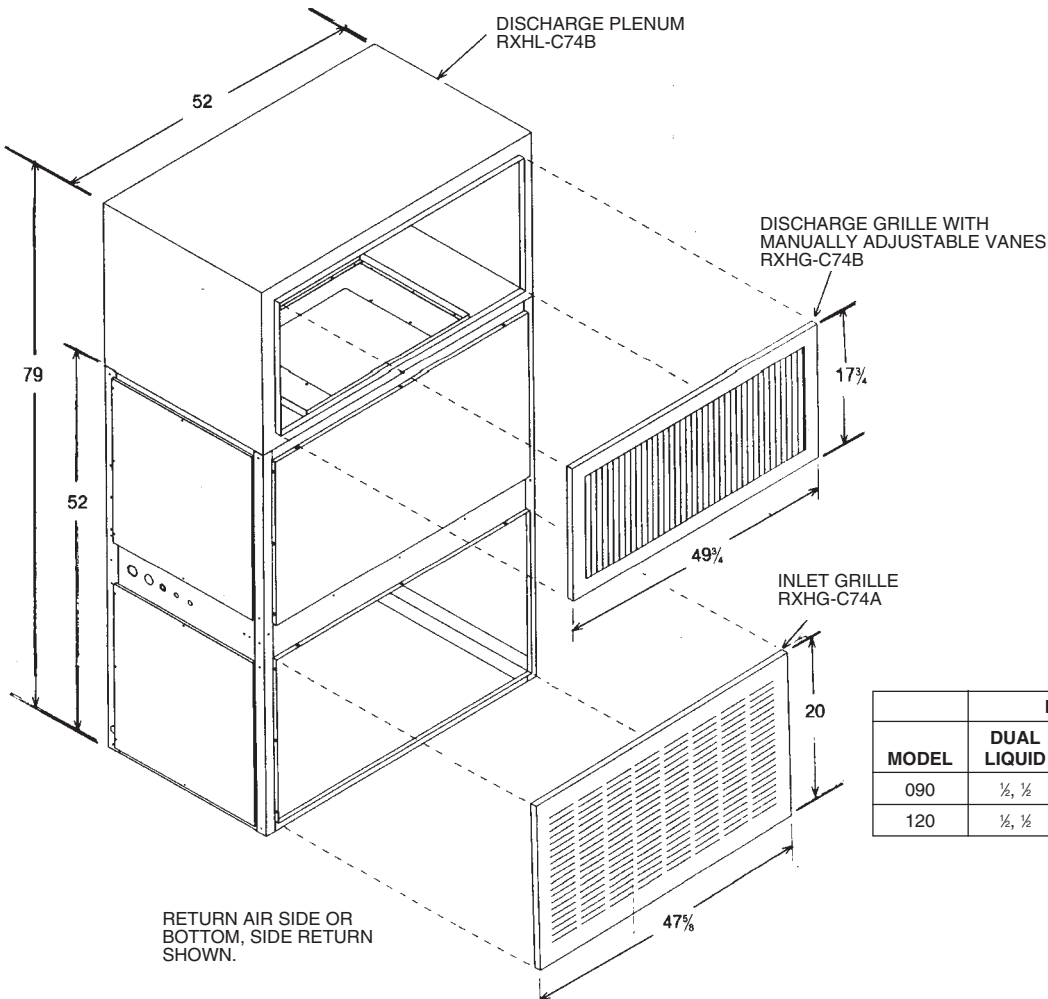

UNIT SHOWN IN VERTICAL POSITION WITH OPTIONAL INLET GRILLE AND OPTIONAL DISCHARGE PLENUM AND DISCHARGE GRILLE

MODEL	REFRIGERANT STUB SIZES			
	DUAL LIQUID	DUAL SUCTION	SINGLE LIQUID	SINGLE SUCTION
090	1/2, 1/2	3/8, 3/8	1/2	1 1/8
120	1/2, 1/2	3/8, 3/8	3/8	1 1/8

PHYSICAL DATA TABLE

MODEL NO. RHGM-			
Cooling Size		090	120
Nominal Size (tons)		7.5	10
Nominal CFM @ Rated E.S.P.		3000 @ .25"	4000 @ .30"
MOTOR HORSEPOWER	Standard— 3450 RPM 1 phase 1750 RPM 3 phase	1 HP 1 HP	2 HP 1½ HP
	Optional— 1750 RPM 3 phase	1½ HP, 2 HP	2 HP, 3 HP
Blower Size—diameter x width		12 x 12	12 x 12
Blower Shaft Diameter		¾	¾
Blower Sheave Diameter (Std.)		10	10
Motor Sheave Size Adjustment (Std.)	3450 RPM 1 phase 1750 RPM 3 phase	1.9-2.9 3.4-4.4	2.4-3.2 4.4-5.0
Belt Type & Size Std.		A-53	A-53
Coil Face Area (sq. ft.)		10.2	10.2
Coil Tube Dia.		¾	¾
Coil, Rows Deep-Fins Per Inch		4/15	4/15
T.X. Valve Refrigerant Control		(2) CBBIZE-5-GA	(2) CBBIZE-6-GA
Filter Size (std.)* No. Req'd		(4) 16 x 25 x 1	(4) 16 x 25 x 1
CABINET:			
Finish		Powder Paint	Powder Paint
Sheet Metal		Galvanized	Galvanized
Gauge; Top		18	18
Sides		16	16
Bottom		18	18
Doors and Covers		20 min.	20 min.
UNIT WEIGHTS:			
Operating		365	372
Shipping		411	418
OPTIONAL ACCESSORIES WEIGHTS:			
Hot Water Coils		200	200
Steam Heating Coils		200	200
Inlet Grille		9	62
Discharge Plenum		38	38
Discharge Grille		15	15

*Unit will accept 2" filters.

DRIVE PACKAGE DATA

NOMINAL TONS	3 PH DRIVE	SHEAVE SELECTIONS*		MOTOR HP / PH	APPROXIMATE BLOWER RPM @ MOTOR SHEAVE TURNS OPEN						
		MOTOR	BLOWER		0	1	2	3	4	5	6
7.5 & 10	K	4.0-5.0	9.75	1 1/2 / 3	885	855	825	795	760	730	
	L	4.6-5.6	9.75	2 / 3	995	960	930	895	860	825	
	M	5.2-6.2	9.75	3 / 3	1100	1060	1020	985	945	905	
	N	4.7-5.7	8.75	3 / 3	1225	1190	1150	1110	1070	1030	
	O	5.7-6.7	8.75	3 / 3	1280	1250	1220	1185	1150	1115	
NOMINAL TONS	1 PH DRIVE	SHEAVE SELECTIONS*		MOTOR HP / PH	APPROXIMATE BLOWER RPM @ MOTOR SHEAVE TURNS OPEN						
		MOTOR	BLOWER		0	1	2	3	4	5	6
7.5 & 10	K	1.9-2.9	8.75	2 / 1	1140	1070	995	920	845	770	

*Actual pitch diameter in inches. Minimum and maximum pitch diameter shown for adjustable motor sheave.

◇ Field supplied (Motor Sheave: Browning IVP75, Blower Sheave: Browning AZ100, Belt: A-50, Motor: 2 HP, 4 Pole, 3)

◊ Field Supplied (Motor Sheave: Browning IVP75, Blower Sheave: Browning AZ80, Belt: A-50)

□ Field Supplied (Motor Sheave: Browning IVP75, Blower Sheave: Browning AZ90, Belt: A-54)

Field Supplied (Motor Sheave: Browning IVP65, Blower Sheave: Browning BK110, Belt: B-50)

7.5 & 10 TON
K DRIVE (WET COIL)

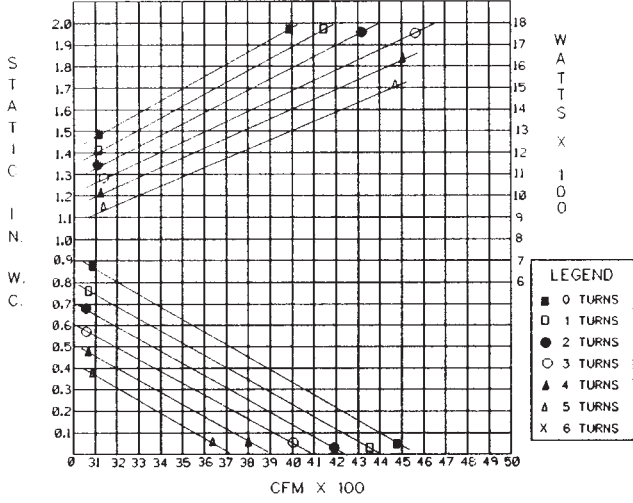

7.5 & 10 TON
L DRIVE (WET COIL)

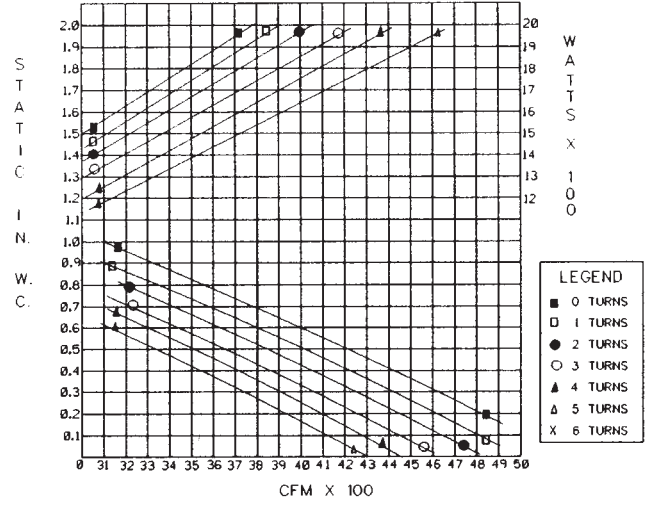

7.5 & 10 TON
M DRIVE (WET COIL)

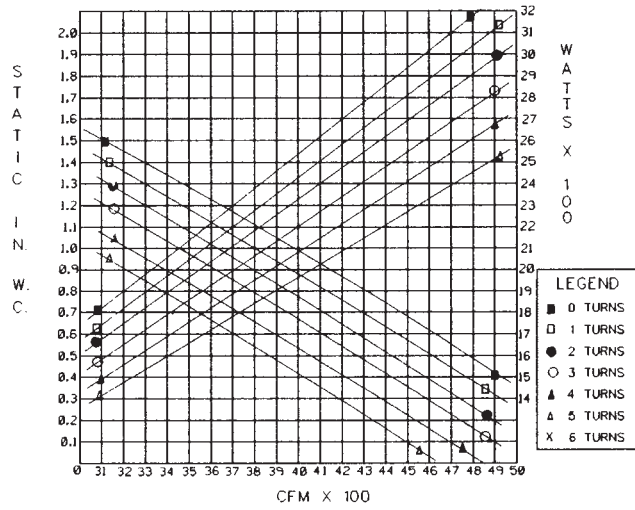

7.5 & 10 TON
N DRIVE (WET COIL)

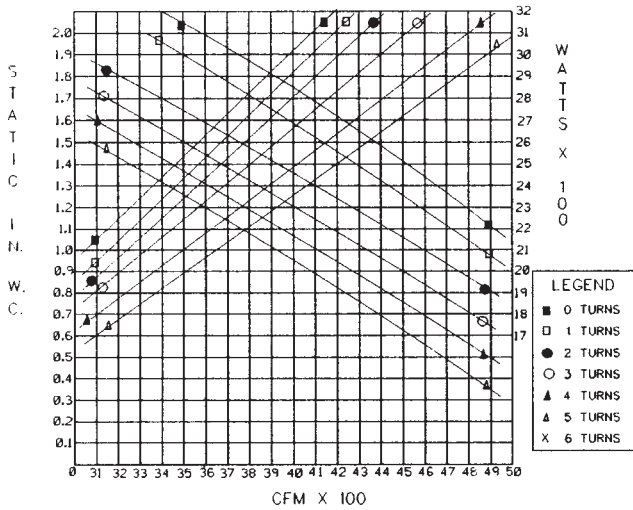

7.5 & 10 TON
O DRIVE (WET COIL)

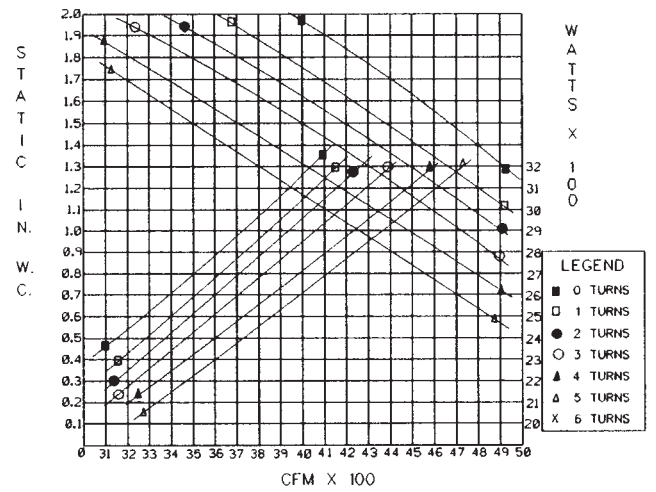

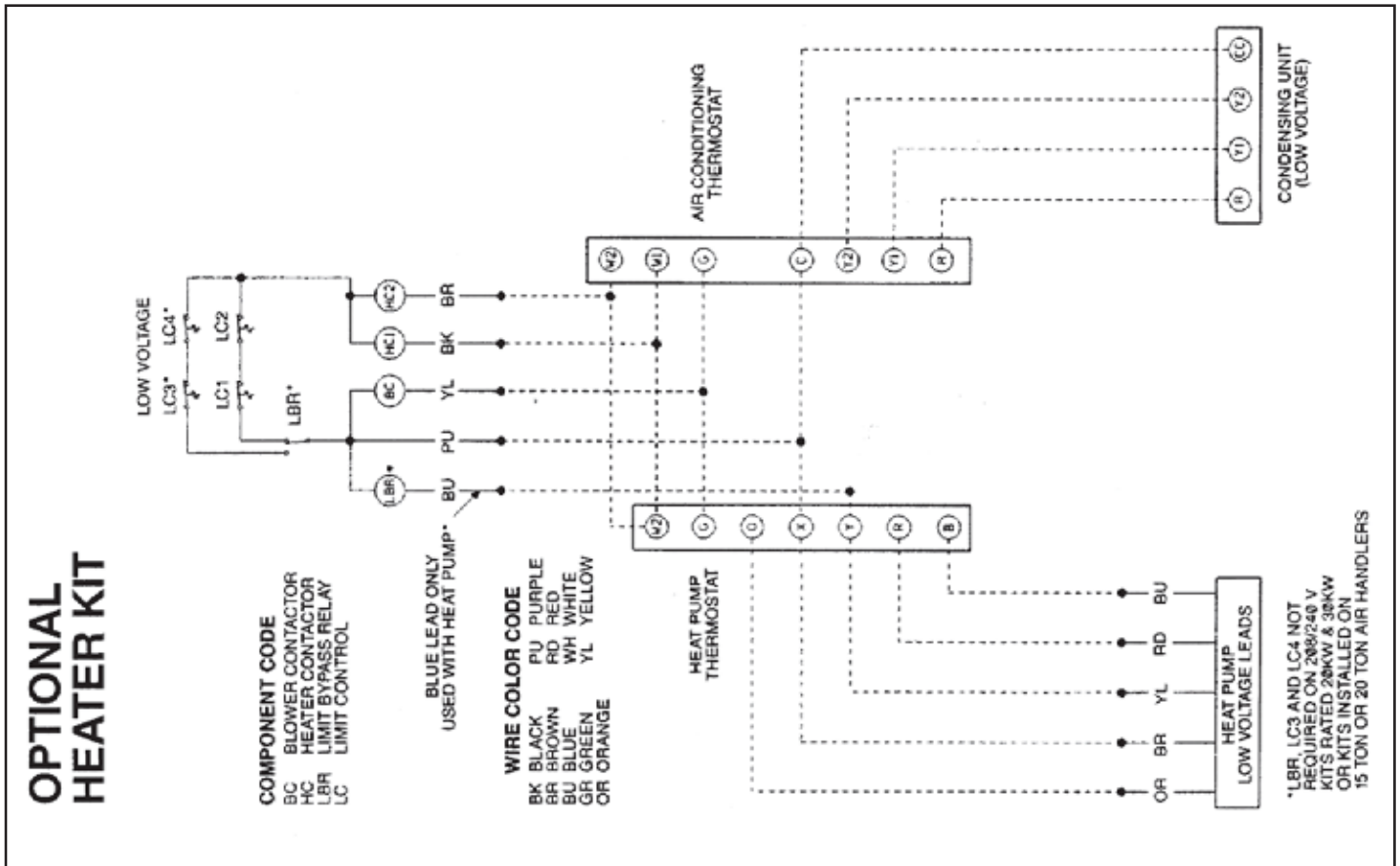
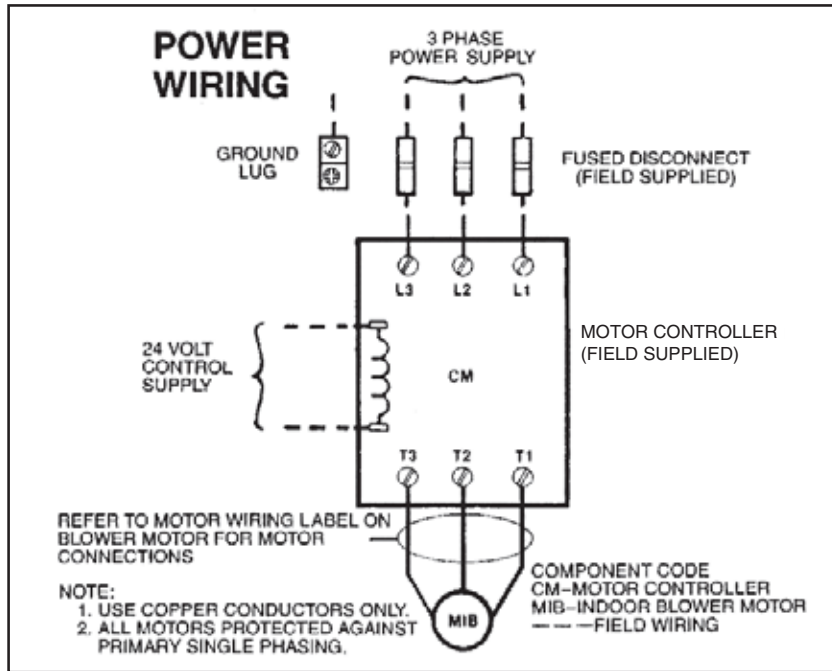

TYPICAL LOW VOLTAGE CONNECTIONS

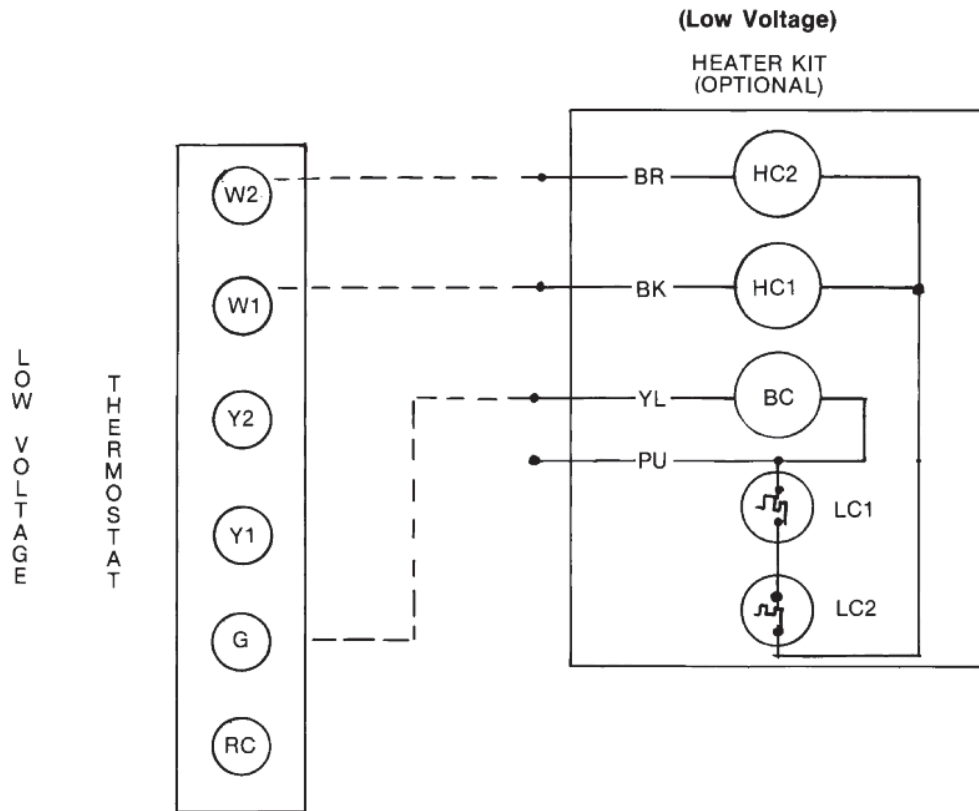

BRANCH CIRCUIT CONDUCTOR DATA (HIGH VOLTAGE)

Air Handler Motor Horsepower, Volts, Ø	Rating Plate Amps	Motor LRA	Minimum Circuit Ampacity	Recommended Minimum Cu Wire Size/Max Run in Feet	Max Fuse or Breakers
1, 208/230, 3 Ø	4.0/3.6	23.9/21.6	15	#14/240	15
1, 460, 3 Ø	1.8	10.8	15	#14/400	15
1, 115/230, 1 Ø	16/8	96/48	20/15	#12/120/#14/180	20/15
1½, 208/230, 3 Ø	5.7/5.2	34.5/31.2	15	#14/230	15
1½, 460, 3 Ø	2.6	15.6	15	#14/300	15
2, 208/230, 3	7.5/6/8	45.1/40.8	15	#14/165	15
2, 460, 3 Ø	3.4	20.4	15	#14/275	15
2, 115/230, 1 Ø	24/12	144/72	30/15	#10/140 #14/120	30/15
3, 208/230, 3 Ø	10.6/9.6	64.1/58	15	#14/135	15
3, 460, 3 Ø	4.8	26.8	15	#14/230	15

FIELD INSTALLED MIXING BOX ACCESSORY 7 1/2 AND 10 ACCESSORY MODEL RXHM-BC74H

COOLING SEASON—Thermostat set at “Cool” and “Fan Auto,” outside air damper goes to “minimum fresh air” position when cooling thermostat closes, energizing mechanical cooling. When cooling thermostat is satisfied, mechanical cooling is de-energized, and outside air damper closes.

INTERMEDIATE SEASON—Same as for cooling season, except that cooling thermostat closes, starting indoor blower motor, the enthalpy control, mounted on outside air, determines if “free” cooling or mechanical cooling should be utilized. If outside air conditions are suitable for cooling, the mechanical cooling remains off and the mixed air controller modulates the damper motor to assume the proper damper position to maintain mixed air setting. If outside conditions are not suitable for cooling, then the dampers go to “minimum fresh air” position and mechanical cooling is energized.

HEATING SEASON—Damper always stays at “minimum fresh air” position while fan motor is operating. Outside air damper closes when blower motor is off. “Minimum fresh air” position must not allow mixed air temperatures to air handler below 50°F. during heating seasons.

CAUTION: Because of the possibility of freeze damage, it is not recommended that hot water or steam coils be used with the mixing box accessory, unless provision is made to shut-off the outside air duct 100% during freezing conditions.

Another possible system enhancement would be to install an air proving switch in the air handler supply duct wired in series with the compressor contactor coil (24V) which would lock out the compressor in the event of air flow failure.

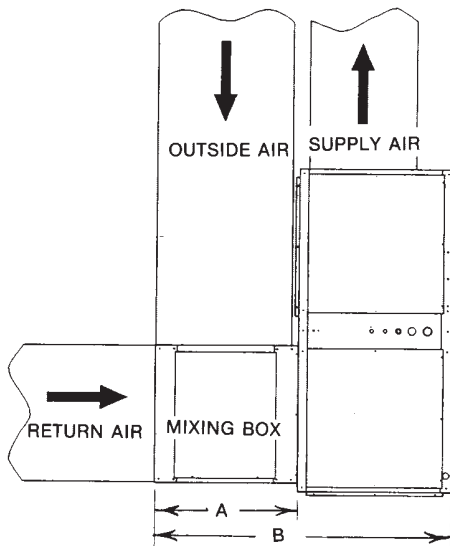

VERTICAL APPLICATION

	A	B
7 1/2 and 10	27	54

HORIZONTAL APPLICATION

	C	D
7 1/2 and 10	27	79

NOTE:

The bottom of the air handler should be sloped in two planes that pitch the condensate to the drain connection. The drain pan shall not leave puddles larger than 2 inches in diameter and 1/8 inch deep for more than 3 minutes.

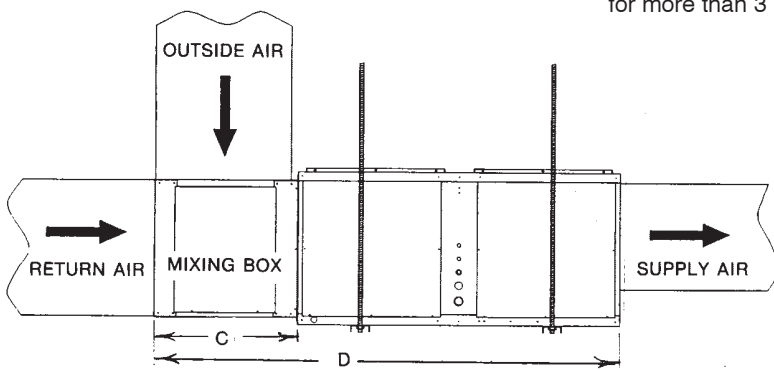

INSPECTION

The complete unit should be examined thoroughly upon receipt, for either hidden or apparent damage, and if necessary, a claim should be entered at once against the last carrier. It is the responsibility of the consignee to file such a claim since the unit is shipped F.O.B. Factory.

LOCATION

The location of the unit must be determined with the following factors in mind: available electric power, plumbing facilities and ample space for arranging the refrigeration equipment, and conforming with proper duct design. In addition, provision should also be made for accessibility to service parts and for complete removal and replacement of any replaceable part.

INSTALLATION

The construction of the building must be substantial enough to support the unit. Set the air handler on a suitable foundation so that the weight is evenly distributed. After locating the unit, shim up the side opposite the drain to allow the water to drain from the pan.

If return air duct is not used, applicable installation codes may limit this cabinet to single story buildings only.

See example of both vertical and horizontal mounting.

The units may also be suspended from the ceiling.

Supply conduit to equipment must terminate at junction box located in the unit.

NOTE: When installed in horizontal position, drain end must be 1/2" lower than leaving air end.

REFRIGERANT PIPING

The following will be of help in accomplishing a successful installation.

1. Size liquid line for no more than 50 PSIG pressure drop.
2. Size suction lines for no more than 2° F loss which corresponds to approximately 5 PSIG pressure drop.
3. When evaporator is installed below condensing unit, do not exceed the recommended suction line O.D. This will insure adequate velocities for proper oil return.
4. Install (optional field installed) sight glass in liquid line.
5. Pitch all horizontal suction lines downward in the direction of flow.
6. When making up refrigerant piping, take every precaution to prevent dirt and moisture from entering the piping.
7. Locate the condensing unit and evaporator(s) as close together as possible to minimize piping runs.

NOTE: Refer to suction and liquid line pressure drop charts found in condensing unit literature.

PIPING SIZES 7.5-10 TONS (INCHES)			
EQUIV. LENGTH TO EVAP. (FT.)	LIQUID LINE O.D.	SUCTION LINE O.D.	
	7.5-10	7.5	10
0-50	5/8"	1 1/8"	1 1/8"
51-100	5/8"	1 1/8"	1 1/8"
101-150	5/8"	1 1/8"	1 1/8"

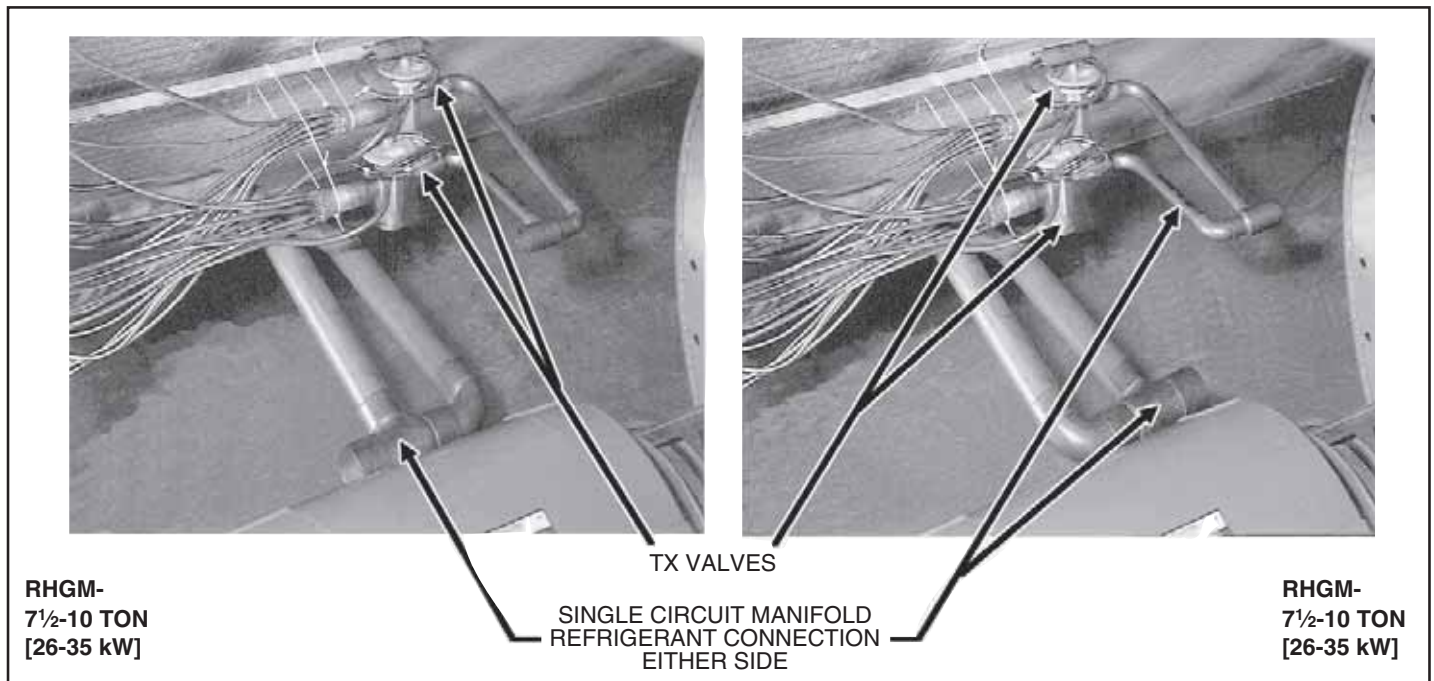

TYPICAL PIPING RECOMMENDATIONS

COIL ABOVE CONDENSING UNIT

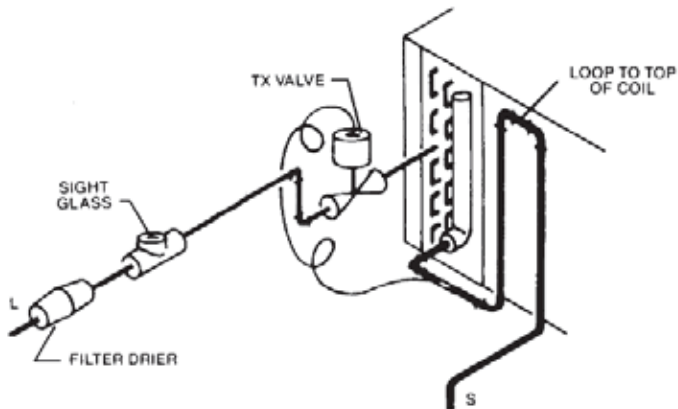

COIL BELOW CONDENSING UNIT

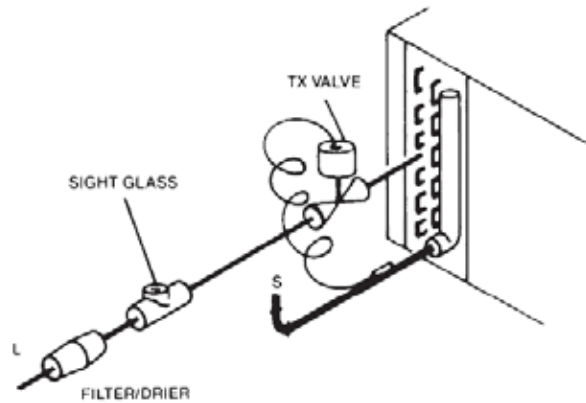

NOTE: PIPING ACCESSORIES SHOWN SHOULD BE MOUNTED AS CLOSE TO AIR HANDLING UNIT AS POSSIBLE.

INSTALLATION OF THE FEELER BULB OF THE EXPANSION VALVE

7.5 - 20 TON UNITS HAVE TWO (2) TX VALVES. THE FEELER BULB OF EACH VALVE SHOULD BE SECURED TO ITS CORRESPONDING SUCTION LINE INSIDE THE UNIT BETWEEN THE EQUALIZED TUBE AND THE TEE FITTING.

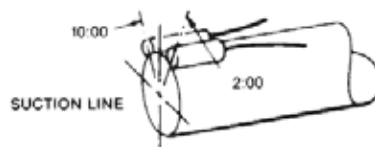

TYPICAL EXPANSION VALVE BULB LOCATIONS

HORIZONTAL UNITS:
LOCATE BULB BETWEEN TEN O'CLOCK AND TWO O'CLOCK ON A STRAIGHT RUN OF LINE NEAR THE EVAPORATOR.

VERTICAL UNITS:
IF THE BULB IS ATTACHED TO THE SUCTION LINE INSIDE THE UNIT, LOCATE IT BETWEEN EIGHT O'CLOCK AND TEN O'CLOCK (BACK SIDE) NEAR THE FIELD CONNECTION. ALWAYS SECURE THE BULB ON A CLEAN, SMOOTH SECTION OF PIPING AND INSULATE IT FROM THE SURROUNDING AMBIENT.

CONDENSATE DRAIN PIPING

- Two drain couplings are provided on all models. Select either one for condensate outlet and plug the other.
- Consult local codes or ordinances for specific requirements regarding condensate drain.
- Condensate drain is open to atmosphere and must be trapped. Trap must be at least 3 inches deep and made of flexible material or fabricated to prevent freeze-up.
- If air handler is installed in a non-conditioned space, it is recommended an auxiliary drain pan be fabricated and installed under entire unit.
- Pitch the drain line at least 1/4 inch per foot away from the drain pan.
- Do not reduce the drain line size from the connection size provided on the unit.
- Do not connect the drain line to a closed sewer line.

IMPORTANT

CONDENSATE DRAIN

INSTALL CONDENSATE DRAIN TRAP AS SHOWN BELOW. USE DRAIN CONNECTION SIZE OR LARGER. DO NOT OPERATE UNIT WITHOUT TRAP. UNIT MUST BE SLIGHTLY INCLINED TOWARD DRAIN.

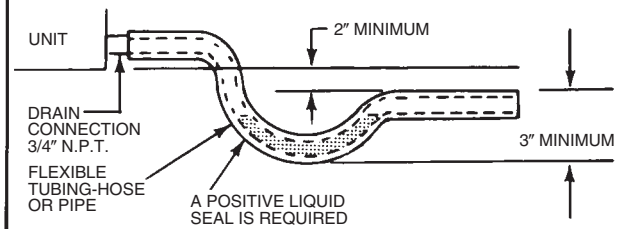

NOTE: TWO OUTLETS ON ALL MODELS.

MOTOR MOUNTING

One of the most critical aspects of an air handler installation is the mounting of the motor, motor sheave, fan pulley and the belts, and the adjustment of these items.

The motor base for the air handlers is raised or lowered by means of the adjusting hex nuts.

MOTOR SHEAVE AND FAN PULLEY MOUNTING AND ADJUSTMENT

The adjustable pitch sheave which is mounted on the motor shaft controls the fan speed. To adjust the fan speed refer to figure at right, proceed as follows:

- Loosen the set screw, item 1.
- Rotate the adjustable sheave, item 2, to the desired position.
- Lock the adjustable sheave in place by tightening the set screw, item 1.

NOTE: The adjustable sheave is not to be used to adjust belt tension.

WARNING

BEFORE MAKING FAN ADJUSTMENTS, BE SURE THE MAIN ELECTRICAL DISCONNECT SWITCH IS IN THE "OFF" POSITION TO PREVENT POSSIBLE INJURY DUE TO ACCIDENTAL OPERATION OF THE MOTOR.

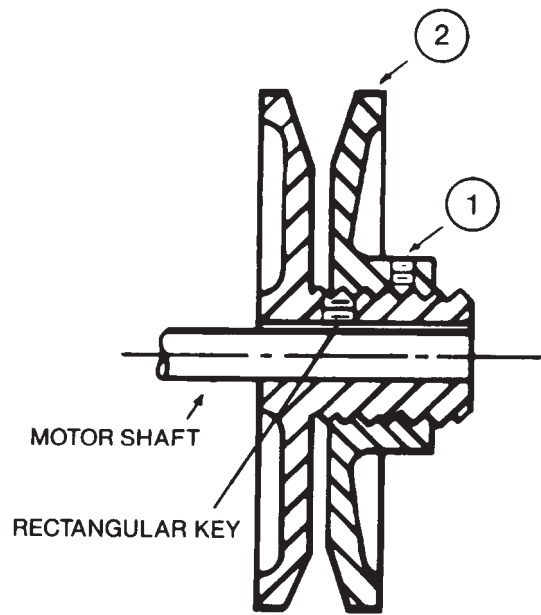

FAN BELT ALIGNMENT AND ADJUSTMENT

Place belt on the groove of the fan pulley and motor sheave to obtain the approximate alignment and belt tension. Remove the belt and align the fan pulley and motor sheave using a straight edge. When the pulley and sheave are properly aligned, re-install belt. Do not force or pry the belt onto the pulley and sheave. With the belt in place, adjust so

that all the slack is on one side of the drive. The belt should have from 3/4" to 1" of slack at 3 lbs. pressure. Adjust the belt to this tension, by raising or lowering the swing base via the adjusting rods and nuts.

PRE-START CHECK LIST

- Leak test entire system.
- Check motor mounting to make sure all nuts are tight.
- Check motor sheave and fan pulley to make sure they are in proper alignment and set screws are tight.
- Check belt tension—belts should be fairly tight for the initial "start-up".
- Check bearing—collar set screws on fan shaft to make sure they are tight.
- Ball type bearings are factory lubricated and do not require additional grease before starting.
- Rotate blower shaft by hand to be sure it is free.
- Check motor and fan rotation.
- Check all screws, bolts, set screws and piping connections for tightness.
- Check drain.
- Insure that filters are in place.
- Insure all manual valves are open.
- Be sure that electrical controls and motors are properly wired and fused in accordance with applicable codes.
- Check wheel position in scrolls. See Figure 1 a and b.

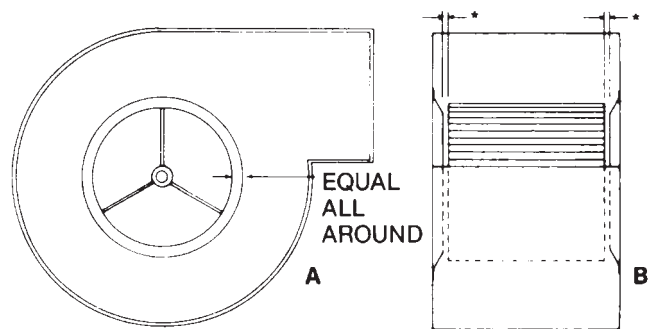

FIGURE 1 * EQUAL

OPERATING INSTRUCTIONS

1. Start fan motor—immediately observe noise level and secure fan motor if unusual sound is heard. Check bearings in particular for proper noise level and temperature. Be sure fans do not rub on scrolls.
2. Check fan RPM and adjust as necessary.
3. Check for motor overloading.
4. Check for proper CFM delivery.
5. Check all necessary items and controls for proper operation.
6. Insure that condensate is being properly discharged from drain pan.

PERIODIC SERVICE AND MAINTENANCE

1. Filters—Dirty filters reduce air flow and, in turn, the capacity of the unit. Therefore, when dirty, replace or clean, depending on the type.
2. Coils—Dirt should not be permitted to build up on the fins of the coils. An air stream or water jet can be used to remove dirt and lint.
3. Check all moving parts for wear and alignment every six (6) months.
4. Check bearing-collar set screws on fan shaft to make sure they are still tight. Do this at least every six months. THIS IS VERY IMPORTANT.

▲ WARNING

BEFORE PERFORMING PERIODIC SERVICE AND MAINTENANCE, BE SURE THE MAIN ELECTRICAL DISCONNECT SWITCH IS IN THE “OFF” POSITION TO PREVENT POSSIBLE INJURY DUE TO ACCIDENTAL OPERATION OF THE MOTOR.

LUBRICATION

GREASING BALL BEARINGS—MOTORS

All ball bearing motors are prelubricated and do not require the addition of grease at time of installation. However, periodic cleaning out and renewal of grease in ball bearings is necessary. Please note that extreme care must be exercised to prevent foreign matter from entering the bearing.

