



aerospace
climate control
electromechanical
filtration
fluid & gas handling
hydraulics
pneumatics
process control
sealing & shielding



Filter-Driers

Catalog A-1, October 2007

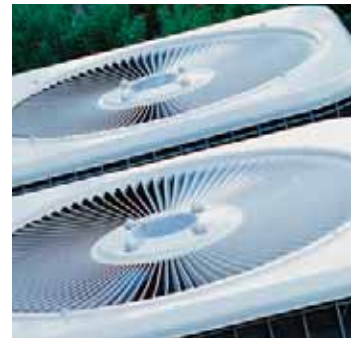

ENGINEERING YOUR SUCCESS.

Table of Contents

Filter-Driers

Introduction to Filter-Driers.....	3
Copper Service Filter-Driers.....	4
Cu LLD® Series Solid-Core Copper Filter-Driers.....	6
Liquid Line Filter-Driers	
Gold Label™ Steel Liquid Line Filter-Drier (LLD Series).....	7
Sahara Series Gold Label™ Liquid Line Filter-Driers.....	10
Steel Bi-flow Filter-Driers (BF Series).....	11
Suction Line Filter-Driers	
Gold Label™ Suction Line Filter-Driers (SLD Series).....	12
Sahara Series™ Suction Line Filter-Driers.....	14
Replaceable Core Shells, Cores and Element	
Replaceable Core Shells, Cores and Element.....	15
Recovery and Reclaim Filters and Pre-Filters	
PF Series.....	18
SPD Series.....	18
Accessories - PRD-3 Series Oil Vapor Drier Separator	
Steel Muffler.....	19
OEM Components	
Granular Copper Filter-Driers.....	20
Granular Spring Loaded Copper Filter-Driers.....	21
CBF Bi-Flow Copper Filter-Driers.....	23

Introduction to Filter-Driers

The function of a filter-drier in a refrigeration system is to remove contaminants that are harmful. If these contaminants remain at elevated levels, they will jeopardize the longevity of the system. Contaminants that are frequently found include moisture, acid, copper oxides, metal chips, wax-like compounds and others.

Selecting a filter-drier for a particular application requires various technical factors to be considered. These factors include the type of system, connecting line size, water capacity, flow capacity (size of system), filtration capability, acid capacity, material of construction (steel vs. copper), and design pressures. Evaluation of each factor is necessary to ensure proper and economical filter-drier design.

Parker has developed filter-drier recommendations based on current technical data, as well as many years of actual field experience. Products are tested for flow and water capacity using the American Society of Heating, Refrigeration and Air Conditioning Engineers (ASHRAE) Standard 63.1 and are rated for use based on the Air Conditioning and Refrigeration Institute's guideline ARI-710. Data obtained from this testing is shown in the capacities tables for liquid line filter-driers and can be used for comparison purposes. However, other factors must be considered for various types of equipment.

Moisture Removal

The ability to remove moisture from a refrigerant system is a primary function of the filter-drier. Moisture can come from many sources such as trapped air from improper evacuation, system leaks, and motor windings, to name a few. Another source is due to improper handling of polyolester (POE) lubricants, which are hygroscopic; that is, they readily absorb moisture. POEs can pick up more moisture from their surroundings and hold it much tighter than the mineral oils which have been used for many years. This moisture can cause freeze-ups and cor-

rosion of metallic components. Moisture in the system can hydrolyze the POE lubricant, forming organic acids. These acids, if they exist in significant quantity, will react with materials within the system and can adversely affect component operation. To prevent the formation of these acids, the moisture must be minimized. This is accomplished by the use of a filter-drier that utilizes molecular sieve and activated alumina.

Molecular sieves are crystalline sodium aluminosilicates (synthetic zeolites) having cubic crystals which selectively adsorb molecules based on molecular size and polarity. The crystal structure is honeycombed with regularly spaced cavities or pores. Each of these cavities or pores are uniform in size. This permits molecules, such as water, to be adsorbed, while allowing other larger molecules, such as the refrigerant, lubricant and acids to pass by. The surface of the desiccant is charged positively with cations, which act as a magnet and will therefore adsorb polarized molecules, such as water, first and hold them tightly on the structure.

Acid Removal

Refrigerants by themselves are very stable, even when heated to a high temperature. However, certain conditions do occur which can result in the formation of acids. The reaction of refrigerants with water may cause hydrolysis and the formation of hydrochloric and hydrofluoric acids. These acids are usually present as a gas in the system and are highly corrosive. In ordinary usage this reaction is negligible, but in a very wet system operating at abnormally high temperature, some hydrolysis may occur.

Another significant source of acidity in refrigeration systems is organic acid formed from lubricant breakdown. As previously discussed, this can be the by-product of the hydrolyzed lubricant. However, organic acids can result from an oxidation reaction of the lubricant (from air left in the system) or

if the thermal stability of the lubricant is exceeded for a period of time from an improper operating system.

Activated alumina is the desiccant of choice if added acid capacity is desired in the filter-drier. Many of the copper spun filter-driers referenced in this catalog are made with a 100% molecular sieve formulation and are not equipped with activated alumina. This is often all that is required for the type of system where they are used, since they minimize the potential of hydrolysis reactions of the lubricant and/or refrigerant. Copper filter-driers are designed with a molecular sieve to achieve the maximum water capacity because they are typically smaller than the steel counterpart and need this capacity. However, copper spun filter-driers are available with molecular sieve/activated alumina formulations if desired.

For steel shell filter-driers, catalog products often utilize a molecular sieve/activated alumina formulation appropriate with current system chemistries. These products come standard with this desiccant blend because these products often find numerous applications in service where the type and amount of contaminants are unknown. For these applications, filter-driers with a blend of molecular sieve and activated alumina is advantageous.

Filtration

Scale, solder particles, metallic fines and all types of foreign substances must be removed to protect the compressor, solenoid valves, expansion valves, capillary tubes and other close tolerance parts of a refrigeration system.

The solution to system filtration is the use of a filter-drier. The filter-drier can be constructed in two different formats to perform this function. The filter-drier can be a spring load desiccant design that utilizes multiple layers of a fibrous media that captures the circulating particulate. The alternate design (always used in large systems) is a molded core

Introduction to Filter-Driers

made with a specific desiccant formulation. The desiccants are sized and bonded in such a way that the useable shape provides the filtration. The large particles are caught on the surface of the core and the smaller solids are captured as the refrigerant channels through the desiccant core.

Steel vs. Copper

The major differences in using steel vs. copper filter-driers are the system sizes and applications. Copper filter-driers are normally used in smaller, less complex applications, systems with less pressure

fluctuations and lower vibration tendencies. Some smaller systems do not require high filtration capabilities; however, some of the smaller systems using the new refrigerants will require better filtration. In order to meet these requirements, a molded core construction and filter-driers with additional fibrous media and screen should be considered. Also, copper is typically the most economical option for smaller systems. Because copper driers are used for smaller applications, the refrigerant charge required will generally be smaller than in the steel filter-drier.

Information regarding operating pressure is required to adequately size the wall thickness of the filter-drier to attain the ultimate burst pressure, for both copper and steel. In accordance with Underwriters Laboratories (UL), the burst pressure is rated as five times the design working pressure of the system, or three times the design working pressure of the system when evaluated using the fatigue stress test outlined in UL 1995. Typically, for copper filter-driers, the design working pressure can be correlated to tube diameter and wall thickness to meet specific UL specifications.

Copper Service Filter-Driers

Parker's service copper filter-driers adsorb moisture and provide filtration to systems. The features of the service copper filter-driers provide contaminant control options to systems in the field.

Applications

- Air conditioning, heat pump, and refrigeration systems

Features and Benefits

- Worldwide OEM acceptance and usage
- All copper construction for corrosion resistance and simplified brazing
- 100% molecular sieve
- Compatible with commercially available refrigerants and lubricants
- UL recognized and CSA certified



Copper Service Filter-Driers

Specifications

Model No.	Part No.	Molecular Sieve (wt.)	Description (Diameter in Inches)	Overall Length		Inlet Tube Size		Outlet Tube Size	
				In.	mm	OD (Inches)	ID (Inches)	OD (Inches)	ID (Inches)
MMS-80	058070-01	10g	3/4 Non-directional	7.38	187	1/4	3/16	1/4	3/16
MMS-100	058198-01	10g	3/4 directional	7.38	187	1/4	3/16	1/4	3/16
MMS-200	032134-01	20g	1 directional step down	10.50	267	1/4	3/16	1/4	3/16
						5/16	1/4	5/16	1/4
						3/8	5/16	3/8	5/16
712	032092-00	10g	3/4 directional	8.50	216	1/4	3/16	.089	.092 cap. tube
319	032144-00	30g	1-3/16 directional	9.75	248	5/16	—	.127	.130
619	032142-00	10g	3/4 w/access valve	8.88	226	1/4	3/16	.089	.092 cap. tube
620	032133-00	20g	1 w/access valve	9.50	241	5/16	1/4	.127	.130 cap. tube
621	032143-00	20g	1 w/double inlet	9.00	229	5/16	1/4	.127	.130 cap. tube
C073S	032145-00	28g	1-5/8 directional	4.38	111	—	3/8	—	3/8

Model No.	Part No.	Recommended Tonnages (kW)							
		R-22	R-134a	R-404A, R-502, R-507	R-410A				
MMS-80	058070-01	1/3 to 2 tons (1 to 7 kW) depending on application and system. Contact Parker for details.							
MMS-100	058198-01								
MMS-200	032134-01								
712	032092-00								
319	032144-00								
619	032142-00								
620	032133-00								
621	032143-00								
C073S	032145-00					4 (14.1 kW)	4 (14.1 kW)	3 (10.6 kW)	4-1/2 (15.8 kW)

Water Capacity In Drops (Grams*) at ARI-710 Conditions

Model No.	Part No.	Water Capacity in Drops									
		R-12		R-22		R-134a		R-401A, R-401B		R-402A, R-402B	
		75°F (24°C)	125°F (52°C)	75°F (24°C)	125°F (52°C)	75°F (24°C)	125°F (52°C)	75°F (24°C)	125°F (52°C)	75°F (24°C)	125°F (52°C)
MMS-80	058070-01	33	30	29	27	32	31	32	30	33	30
MMS-100	058198-01	33	30	29	27	32	31	32	30	33	30
MMS-200	032134-01	66	61	59	54	65	62	65	60	66	61
712	032092-00	33	30	29	27	32	31	32	30	33	30
319	032144-00	99	91	89	82	97	93	97	90	99	91
619	032142-00	33	30	29	27	32	31	32	30	33	30
620	032133-00	66	61	59	54	65	62	65	60	66	61
621	032143-00	66	61	59	54	65	62	65	60	66	61
C073S	032145-00	92	85	83	76	91	86	91	84	92	85

Model No.	Part No.	Water Capacity in Drops							
		R-404A, R-507		R-407C		R-410A		R-502	
		75°F (24°C)	125°F (52°C)	75°F (24°C)	125°F (52°C)	75°F (24°C)	125°F (52°C)	75°F (24°C)	125°F (52°C)
MMS-80	058070-01	32	30	26	23	19	17	30	28
MMS-100	058198-01	32	30	26	23	19	17	30	28
MMS-200	032134-01	65	61	52	47	39	34	60	57
712	032092-00	32	30	26	23	19	17	30	28
319	032144-00	98	91	78	70	59	52	91	85
619	032142-00	32	30	26	23	19	17	30	28
620	032133-00	65	61	52	47	39	34	60	57
621	032143-00	65	61	52	47	39	34	60	57
C073S	032145-00	91	85	73	66	55	48	85	80

* 20 Drops = 1 Gram = 1 cc

Cu LLD® Series Molded Core Copper Filter-Driers

Parker's solid-core copper filter-driers adsorb system contaminants and provide physical filtration to systems between 1/2 and 5 tons (1.8 to 17.5 kW). Applications include air conditioning, heat pumps, and small refrigeration systems.

Application

- System sizes between 1/2 to 5 tons (1.8 to 17.5 kW)

installation

- 100% molecular sieve molded core for maximum water capacity
- Copper construction offers excellent corrosion resistance in harsh environments

Features and Benefits

- One-piece copper shells in 1-3/16" to 2" (30.2 to 50.8 mm) outside diameter, along with spun ODF solder fittings in a variety of sizes, provides easy

Base Product Part No.

- Cu LLD



Water Capacity In Drops (Grams*) at ARI-710 Conditions

Model No.	Fitting Type ODF Solder (Inches)	Overall Length		Tube Diameter		R-22 (60 ppm)		R-134a (50 ppm)		R-404A, R-507 (50 ppm)		R-407C (50 ppm)		R-410A (50 ppm)	
		Inches	mm	Inches	mm	75°F (24°C)	125°F (52°C)	75°F (24°C)	125°F (52°C)	75°F (24°C)	125°F (52°C)	75°F (24°C)	125°F (52°C)	75°F (24°C)	125°F (52°C)
Cu LLD 3-2S	1/4	4.71	120	1.63	41	63	55	69	62	68	61	48	41	37	31
Cu LLD 3-3S	3/8	4.71	120	1.63	41	63	55	69	62	68	61	48	41	37	31
Cu LLD 5-3S	3/8	6.06	154	2.60	66	86	75	94	85	94	83	66	56	51	43
Cu LLD 8-3S	3/8	6.68	170	2.00	51	150	131	165	147	164	145	115	98	89	75
Cu LLD 16-3S	3/8	6.68	170	2.00	51	241	209	263	236	261	223	173	147	142	119

* 20 Drops = 1 Gram = 1 cc

Installation Recommendations

Model No.	Nominal Ratings in Tons (kW)											
	Refrigeration Commercial Low Temp. Equipment						Air Conditioning OEM, Self-Contained/Field Replacement					
	R-134a		R-22		R-404A, R-507		R-134a		R-22, R-410A		R-404A, R-407C, R-507A	
	Tons	kW	Tons	kW	Tons	kW	Tons	kW	Tons	kW	Tons	kW
Cu LLD 3-2S	3/4	2.6	3/4	2.6	1/2	1.8	1-1/2	5.3	1-1/2	5.3	1	3.5
Cu LLD 3-3S	1-3/4	6.1	1-1/2	5.3	1-3/4	6.1	3-1/2	12.3	3	10.5	2-1/2	8.8
Cu LLD 5-3S	1-3/4	6.1	1-1/2	5.3	1-3/4	6.1	3-1/2	12.3	3	10.5	2-1/2	8.8
Cu LLD 8-3S	2	7.0	1-1/2	5.3	1-3/4	6.1	3-1/2	12.3	3	10.5	2-1/2	8.8
Cu LLD 16-3S	2	7.0	1-1/2	5.3	1-3/4	6.1	4	14	3-1/2	12.3	2-1/2	8.8

Flow Capacity – Tons (kW) of Refrigeration at 1 psid (.07 Bar)

Model No.	R-22		R-134a		R-404A, R-507		R-407C		R-410A	
	Tons	kW	Tons	kW	Tons	kW	Tons	kW	Tons	kW
Cu LLD 2-3S	2.9	10.2	2.6	9.1	1.9	6.7	2.9	10.2	2.8	9.8
Cu LLD 3-2S	1.9	6.7	1.7	4.9	1.2	4.2	1.8	6.3	1.8	6.3
Cu LLD 3-3S	4.3	15.1	3.9	13.7	2.8	9.8	4.2	14.7	4.2	14.7
Cu LLD 5-3S	4.2	14.7	3.8	13.3	2.7	9.5	4.1	14.4	4.1	14.4
Cu LLD 8-3S	4.6	16.1	4.2	14.7	3.0	10.5	4.5	15.8	4.5	15.8
Cu LLD 16-3S	4.8	16.8	4.4	15.4	3.1	10.9	4.7	16.5	4.6	16.1

Gold Label Steel Liquid Line Filter-Driers

LLD Series

Features and Benefits

- Unsurpassed moisture and acid capacities – maximum filtration capability for today’s systems
- Compatible with all commercially available refrigerants including R-410A
- Compatible with mineral oil, alkybenzene and POE lubricants
- Spring loaded, molecular sieve and activated alumina
- Solid copper ODF solder fittings and nickel plated steel SAE fittings
- Powder paint exterior coating surpasses 500 hour ASTM salt spray test to resist corrosion
- Models 030 thru 160 series are rated for 600 psig. Models 300, 410 and 750 series are rated for 500 psig
- U.L. listed SA3441



Water Capacity In Drops (Grams*) at ARI-710 Conditions

Model Series	R-22 (60 ppm)		R-134a (50 ppm)		R-404A, R-507 (50 ppm)		R-407C (50 ppm)		R-410A (50 ppm)	
	75°F (24°C)	125°F (52°C)	75°F (24°C)	125°F (52°C)	75°F (24°C)	125°F (52°C)	75°F (24°C)	125°F (52°C)	75°F (24°C)	125°F (52°C)
030	71	66	78	74	78	73	55	49	42	37
050	177	160	196	185	194	182	127	115	87	78
080	250	230	277	262	273	257	180	162	124	111
160	358	325	395	375	389	367	258	232	178	159
300	755	698	826	786	822	773	579	521	446	397
410	1053	973	1151	1096	1145	1078	806	726	622	554
750	1607	1485	1757	1673	1748	1645	1231	1109	949	846

* 20 Drops = 1 Gram = 1 cc

Refrigerant Holding Capacity – Ounces (kg) of refrigerant @ 100°F (38°C)

Model Series	R-12		R-22		R-134a		R-404A, R-507		R-407C		R-410A		R-502	
	Ounces	kg	Ounces	kg	Ounces	kg	Ounces	kg	Ounces	kg	Ounces	kg	Ounces	kg
030	1.9	0.5	1.7	0.5	1.8	0.5	1.5	0.4	1.5	0.4	1.5	0.4	1.8	0.5
050	3.3	0.9	3.0	0.9	3.0	0.9	2.6	0.7	2.8	0.8	2.6	0.7	2.9	0.8
080	6.1	1.7	5.5	1.6	5.6	1.6	4.8	1.4	5.3	1.5	4.8	1.4	5.4	1.5
160	9.1	2.6	8.2	2.3	8.4	2.4	7.1	2.0	7.8	2.2	7.2	2.0	8.0	2.3
300	26.7	7.3	24.2	6.9	24.5	6.9	20.7	5.9	20.8	5.9	21.1	6.0	24.4	6.9
410	37.3	10.6	33.8	9.6	34.2	9.7	29.0	8.2	29.0	8.2	29.4	8.3	34.1	9.7
750	71.3	20.2	64.5	18.3	65.3	18.5	55.3	15.7	56.5	16	56.2	15.9	65.2	18.5

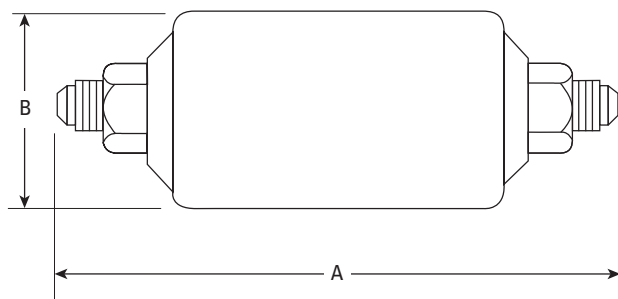
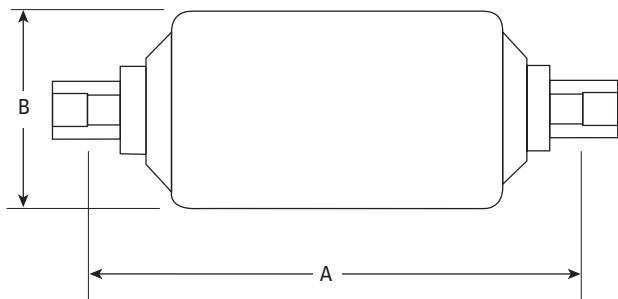

Gold Label Steel Liquid Line Filter-Driers

Flow Capacity – Tons of Refrigeration at 1 psid (0.07 bar)

Model No.	Fitting Type (Inches)	Overall Length Inches		Shell Diameter		Flow Capacity – Tons (kW) @ 1 psid (0.07 bar)									
		Inches	mm	Inches	mm	R-22		R-134a		R-404A, R-507		R-407C		R-410A	
						Tons	kW	Tons	kW	Tons	kW	Tons	kW	Tons	kW
032	1/4 SAE Flare	4.16	106	1.66	42	1.70	6.0	1.54	5.4	1.10	3.9	1.64	5.7	1.67	5.8
032S	1/4 ODF Solder	3.73	95	1.66	42	1.84	6.4	1.72	6.0	1.22	4.3	1.82	6.4	1.86	6.5
032MF	1/4 male x female flare	3.91	99	1.66	42	1.70	6.0	1.54	5.4	1.10	3.9	1.64	5.7	1.67	5.8
052	1/4 SAE Flare	4.88	124	2.38	60	1.84	6.4	1.72	6.0	1.22	4.3	1.82	6.4	1.86	6.5
052S	1/4 ODF Solder	4.38	124	2.38	60	2.05	7.2	1.80	6.3	1.29	4.5	1.91	6.7	1.95	6.8
0525S	5/16 ODF Solder	4.38	124	2.38	60	3.32	11.6	3.00	10.5	2.14	7.5	3.19	11.2	3.25	11.4
053	3/8 SAE Flare	5.25	133	2.38	60	3.96	13.9	3.60	12.6	2.57	9.0	3.83	13.4	3.90	13.7
053S	3/8 ODF Solder	4.38	124	2.38	60	4.74	16.6	4.29	15.0	3.06	10.7	4.56	16.0	4.64	16.2
082	1/4 SAE Flare	5.63	143	2.38	60	1.84	6.4	1.72	6.0	1.22	4.3	1.82	6.4	1.86	6.5
082S	1/4 ODF Solder	5.25	133	2.38	60	2.12	7.4	1.89	6.6	1.35	4.7	2.01	7.0	2.04	7.1
0825S	5/16 ODF Solder	5.25	133	2.38	60	3.46	12.1	3.17	11.1	2.27	7.9	3.37	11.8	3.43	12.0
083	3/8 SAE Flare	6.00	152	2.38	60	4.45	15.6	4.03	14.1	2.88	10.1	4.28	15.0	4.36	15.3
083S	3/8 ODF Solder	5.25	133	2.38	60	5.02	17.6	4.54	15.9	3.25	11.4	4.83	16.9	4.92	17.2
084	1/2 SAE Flare	6.38	162	2.38	60	7.14	25.0	6.43	22.5	4.59	16.1	6.84	23.9	6.96	24.4
084S	1/2 ODF Solder	5.38	137	2.38	60	7.21	25.2	6.52	22.8	4.65	16.3	6.93	24.2	7.05	24.7
162	1/4 SAE Flare	6.31	160	2.38	60	2.19	7.6	1.97	6.9	1.41	4.9	2.10	7.4	2.13	7.5
162S	1/4 ODF Solder	5.88	149	2.38	60	2.40	8.4	2.14	7.5	1.53	5.4	2.28	8.0	2.32	8.1
1625S	5/16 ODF Solder	5.88	149	2.38	60	4.03	14.1	3.69	12.9	2.63	9.2	3.92	13.7	3.99	14.0
163	3/8 SAE Flare	6.75	171	2.38	60	5.30	18.6	4.80	16.8	3.43	12.0	5.10	17.9	5.20	18.2
163S	3/8 ODF Solder	5.94	151	2.38	60	5.94	21.8	5.32	18.6	3.80	13.3	5.65	19.8	5.75	20.1
164	1/2 SAE Flare	7.00	178	2.38	60	9.05	31.7	8.15	28.5	5.82	20.4	8.66	30.3	8.81	30.8
164S	1/2 ODF Solder	6.06	154	2.38	60	9.83	34.4	8.83	30.9	6.31	22.1	9.39	32.8	9.56	33.5
165	5/8 SAE Flare	7.25	194	2.38	60	12.58	44.0	11.40	39.9	8.15	28.5	12.12	42.4	12.34	43.2
165S	5/8 ODF Solder	6.31	160	2.38	60	13.01	45.5	11.75	41.1	8.39	29.4	12.49	43.7	12.71	44.5
303	3/8 SAE Flare	9.69	246	3.00	76	5.44	19.2	4.89	17.1	3.49	12.2	5.19	18.2	5.29	18.5
303S	3/8 ODF Solder	8.86	225	3.00	76	6.15	21.5	5.57	19.5	3.98	13.9	5.92	20.7	6.03	21.1
304	1/2 SAE Flare	9.94	252	3.00	76	10.75	31.6	9.69	33.9	6.92	24.2	10.30	36.1	10.48	36.7
304S	1/2 ODF Solder	9.00	229	3.00	76	12.44	43.5	11.23	39.3	8.02	28.1	11.94	41.8	12.15	42.5
305	5/8 SAE Flare	10.19	259	3.00	76	14.71	51.4	13.29	46.5	9.49	33.2	14.13	49.5	14.38	50.3
305S	5/8 ODF Solder	9.24	235	3.00	76	16.26	56.9	14.66	51.3	10.47	36.6	15.58	54.5	15.86	55.5
306	3/4 SAE Flare	10.44	265	3.00	76	16.47	57.6	14.92	52.2	10.66	37.3	15.86	55.5	16.14	56.5
307S	7/8 ODF Solder	9.30	236	3.00	76	20.15	70.5	18.18	63.6	12.98	45.4	19.32	67.6	19.67	68.8
413	3/8 SAE Flare	9.88	251	3.50	311	5.44	19.0	4.89	17.1	3.49	12.2	5.19	18.2	5.29	18.5
413S	3/8 ODF Solder	9.05	230	3.50	311	6.15	21.5	5.57	19.5	3.98	13.9	5.92	20.7	6.03	21.1
414	1/2 SAE Flare	10.13	257	3.50	311	10.82	37.9	9.78	34.2	6.98	24.4	10.39	36.3	10.58	37.0
414S	1/2 ODF Solder	9.20	234	3.50	311	12.44	43.5	11.23	39.3	8.02	28.1	11.94	41.8	12.15	42.5
415	5/8 SAE Flare	10.38	264	3.50	311	14.71	51.4	13.29	46.5	9.49	33.2	14.13	49.5	14.38	50.3
415S	5/8 ODF Solder	9.43	240	3.50	311	16.26	56.9	14.66	51.3	10.47	36.6	15.58	54.5	15.86	55.5
417S	7/8 ODF Solder	9.49	241	3.50	311	23.12	80.9	20.84	72.9	14.88	52.1	22.15	77.5	22.54	78.9
756S	3/4 ODF Solder	15.11	384	3.50	311	19.65	68.8	17.75	62.1	12.68	44.4	18.87	66.0	19.20	67.2
757S	7/8 ODF Solder	15.11	384	3.50	311	24.32	85.1	22.04	77.1	15.74	55.1	23.42	82.0	23.84	83.4
759S	1-1/8 ODF Solder	15.99	406	3.50	311	26.80	93.8	24.27	84.9	17.33	60.7	25.79	90.3	26.26	91.9

Note: Models 083S-XF, 163S-XF and 303S-XF are available with modified three angstrom molecular sieve for R-410A.

Sahara Series™ Liquid Line Filter-Driers

Available only from your local Parker wholesaler, the Sahara Series is a service replacement filter-drier for air conditioning applications.

Features & Benefits

- High moisture and filtration capacity
- Compatible with POEs, alkylbenzenes and mineral oils
- Compatible with R-12, R-22, R-134a, R-407C and R-410A
- Copper ODF solder fittings
- Powder paint exterior coating surpasses 500 hour ASTM salt spray test to resist corrosion
- 600 psig (41.4 bar) design pressure. U.L. File No. SA3441



Water Capacity In Drops (Grams*) at ARI-710 Conditions

Model	R-22 (60 ppm)		R-134a (50 ppm)		R-407C (50 ppm)		R-410A (50 ppm)	
	75°F (24°C)	125°F (52°C)	75°F (24°C)	125°F (52°C)	75°F (24°C)	125°F (52°C)	75°F (24°C)	125°F (52°C)
SS-053S	82	75	89	85	68	58	46	44
SS-083S	106	97	115	110	88	75	60	57
SS-163S	188	173	205	195	156	133	105	102

* 20 Drops = 1 Gram = 1 cc

Refrigerant Holding Capacity – Ounces (kg) of refrigerant @ 100°F (38°C)

Model	Internal Volume (Cubic Inches)	R-22		R-134a		R-407C		R-410A	
		Ounces	kg	Ounces	kg	Ounces	kg	Ounces	kg
SS-053S	5.6	7.8	2.2	7.9	2.2	7.3	2.1	6.7	1.9
SS-083S	9.4	10.0	2.8	10.1	2.9	9.4	2.7	8.6	2.4
SS-163S	13.1	11.4	3.2	11.6	3.3	10.9	3.1	9.8	2.8

Dimensions

Model No. (ODF Solder)	ODF Solder (Inches)	Cutout Length "A"		Overall Length "B"	
		Inches	mm	Inches	mm
SS-053S	3/8	3.25	83	4.39	112
SS-083S	3/8	4.13	105	5.27	134
SS-163S	3/8	4.75	121	5.92	150

Note: For additional performance capacities, specify the Parker Gold Series Filter-Driers (page 7).

ODF Solder

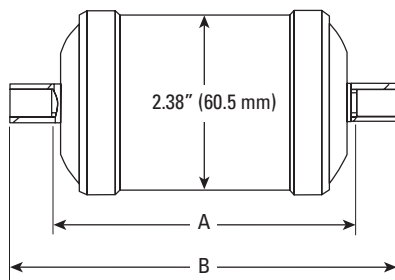

Steel Bi-Flow Filter-Driers – BF Series

The BF Series bi-flow filter-drier is designed specifically for heat pump or reverse cycle applications. External check valves are not required since they are incorporated within the filter-drier.

Features and Benefits

- 100% copper ODF solder or nickel plated flare fittings
- Desiccant core provides reliable and effective removal of solid contaminants, acid and moisture
- Model BF-163(S)-XF features R-32 excluding desiccant for R-410A and alternative
- internal construction for added filtration
- Core is cushioned in fiber gaskets to protect core and to ensure trouble-free performance
- Powder paint exterior coating surpasses 500 hour ASTM salt spray test to resist corrosion
- U.L. listed file SA3441



Dimensions

Model No.		Fitting Size (Inches)	System Cutout Length "A"		System Cutout Length "B"		System Cutout Length "C"		Shell Diameter "D"	
Flare	ODF Solder		Inches	mm	Inches	mm	Inches	mm	Inches	mm
—	BF082S	1/4	—	—	4.10	104	5.27	134	2.50	64
BF083	BF083S	3/8	6.09	155	4.10	104	5.27	134	2.50	64
BF084	BF084S	1/2	6.35	161	4.10	104	5.41	137	2.50	64
—	BF162S	1/4	—	—	4.10	104	5.92	150	2.50	64
BF163	BF163S	3/8	6.75	171	4.75	121	5.92	150	2.50	64
—	BF163S-XF	3/8	6.09	155	6.76	172	7.56	192	3.00	76
BF164	BF164S	1/2	7.00	178	4.75	121	6.06	154	2.50	64
—	BF165S	5/8	—	—	4.75	121	6.30	160	2.50	64

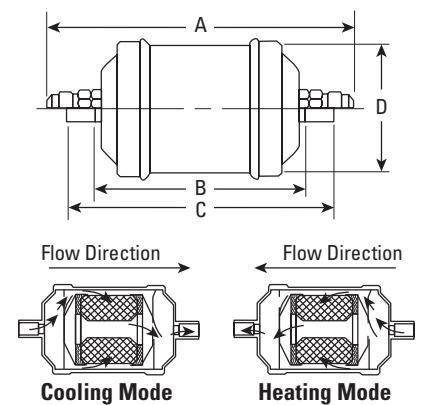

Refrigerant Holding Capacity – Ounces (kg) of refrigerant @ 100°F (38°C)

Model Series	R-12		R-22		R-134a		R-404A, R-507		R-407C		R-410A		R-502	
	Ounces	kg	Ounces	kg	Ounces	kg	Ounces	kg	Ounces	kg	Ounces	kg	Ounces	kg
BF080	8.2	2.3	7.4	2.1	7.5	2.1	6.3	1.8	7.0	2.0	6.4	1.8	7.5	2.1
BF160	9.5	2.7	8.6	2.4	8.7	2.5	7.4	2.1	8.2	2.3	7.5	2.1	8.7	1.1
BF160-XF	15.5	4.4	14.0	4.0	14.2	3.5	12.0	3.4	13.2	3.7	12.2	3.5	14.2	4.0

Water Capacity In Drops (Grams*) at ARI-710 Conditions

Model Series	R-22 (60 ppm)		R-134a (50 ppm)		R-404A, R-507 (50 ppm)		R-407C (50 ppm)		R-410A (50 ppm)	
	75°F (24°C)	125°F (52°C)	75°F (24°C)	125°F (52°C)	75°F (24°C)	125°F (52°C)	75°F (24°C)	125°F (52°C)	75°F (24°C)	125°F (52°C)
BF080	95	88	104	99	104	98	73	65	56	50
BF160	134	124	147	140	148	138	103	93	79	71
BF160-XF	168	155	184	175	185	173	197	176	197	176

* 20 Drops = 1 Gram = 1 cc

Flow Capacity — Tons (kW) of Refrigeration at 1 psid (0.07 bar)

Model No.	Filter Area (cu inches)	R-22		R-134a		R-404A, R-507		R-407C		R-410A	
		Tons	kW	Tons	kW	Tons	kW	Tons	kW	Tons	kW
BF082S	10.4	2.1	7.4	1.9	6.7	1.4	4.9	2.0	7.0	2.1	7.4
BF083S		2.8	8.4	2.6	9.1	1.8	6.3	2.7	9.5	2.8	9.8
BF084S		3.5	12.2	3.2	11.2	2.3	8.1	3.4	11.9	3.5	12.3
BF083		2.8	8.4	2.6	9.1	1.8	6.3	2.7	9.5	2.8	9.8
BF084		3.5	12.2	3.2	11.2	2.3	8.1	3.4	11.9	3.5	12.3
BF162S	14.4	2.1	7.4	1.9	6.7	1.4	4.9	2.0	7.0	2.1	7.4
BF163S		2.9	10.2	2.6	9.1	1.9	6.7	2.8	9.8	2.9	10.2
BF164S		3.5	12.2	3.2	11.2	2.3	8.1	3.4	11.9	3.5	12.3
BF165S		4.9	17.2	4.5	15.8	3.2	11.2	4.8	15.4	4.9	17.2
BF163		2.8	9.8	2.6	9.1	1.8	6.3	2.7	9.5	2.8	9.8
BF164	3.5	12.3	3.2	11.2	2.3	8.1	3.4	11.9	3.5	12.3	
BF163S-XF	14.4	3.6	12.6	3.3	11.6	2.3	8.1	3.5	12.3	3.5	12.3
BF163-XF		2.8	9.8	2.6	9.1	1.8	6.3	2.7	9.5	2.8	9.8

Gold Label Steel Suction Line Filter-Driers

SLD Series

The SLD Series is a solid core clean-up filter-drier for use in the suction line. The compact design incorporates a large outside diameter shell, which results in a shorter lay-in length, and a larger core, which provides a greater filtration area for maximum operating efficiency.

The core material has controlled porosity which effectively removes and holds a maximum amount of contaminants with a minimal pressure drop. In addition, the core material collects and holds acids and other harmful contaminants present after a motor burnout.

Access valves on both the inlet and outlet sides make it easy to measure pressure accurately. Occasionally, enough contaminant matter may collect in the filter core to cause a slight pressure drop. The access valves on the SLD make it easy to determine if added pressure drop exists across the filter-drier.



Features and Benefits

- Molded porous core
- High acid capacity
- Low pressure drop — exceptionally high flow rates
- Designed for system clean-up
- 500 hours salt spray protection
- Short system cut-out lengths allow installation in tight areas
- Two access valves simplify pressure drop measurement
- Flare or ODF Solder fittings
- UL listed — File No. SA3441

Steel Suction Line Filter-Drier Dimensions

Model No.	"A" Overall Length		"B" System Cutout Length		Shell Diameter	
	Inches	mm	Inches	mm	Inches	mm
SLD 8-3V-HH	5.13	130	—	—	3.00	76
SLD 8-3SV-HH	4.31	109	3.13	80	3.00	76
SLD 8-4V-HH	5.38	137	—	—	3.00	76
SLD 8-4SV-HH	4.44	113	3.13	80	3.00	76
SLD 8-5SV-HH	4.66	118	3.16	80	3.00	76
SLD 8-6SV-HH	4.72	120	3.16	80	3.00	76
SLD8-7SV-HH	4.72	120	3.16	80	3.00	76
SLD 13-5V-HH	5.82	148	—	—	4.00	102
SLD 13-5SV-HH	4.91	125	3.45	88	4.00	102
SLD 13-6SV-HH	4.97	126	3.45	88	4.00	102
SLD 13-7SV-HH	4.97	126	3.47	88	4.00	102
SLD 13-9SV-HH	5.72	145	3.47	88	4.00	102
SLD 27-7SV-HH	6.97	170	5.47	139	4.00	102
SLD 27-9SV-HH	7.72	196	5.47	139	4.00	102
SLD 54-11SV-HH	12.0	305	9.17	233	4.00	102
SLD 54-13SV-HH	12.0	305	9.17	233	4.00	102

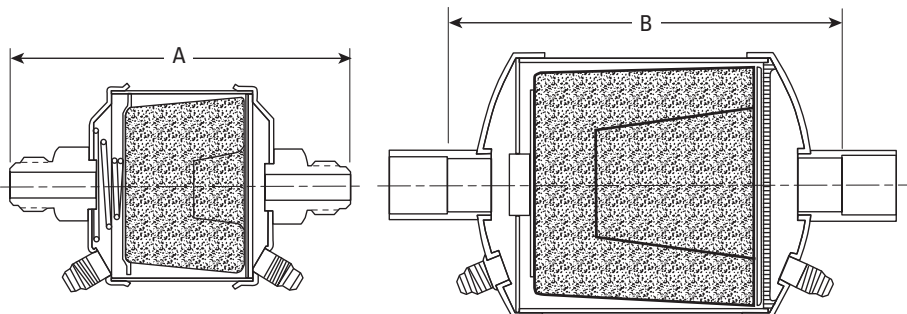

Steel Suction Line Filter-Drier

Water Capacity In Drops (Grams*) at 65°F (18°C)

Model No.	Fitting (Inches)	Desiccant (Cu. In.)	Filter Area (Sq. In.)	R-22	R-134	R-404A, R-507	R-410A
SLD 8-3V-HH	3/8 SAE Flare	8	17	168	168	185	200
SLD 8-3SV-HH	3/8 ODF Solder	8	17	168	168	185	200
SLD 8-4V-HH	1/2 SAE Flare	8	17	168	168	185	200
SLD 8-4SV-HH	1/2 ODF Solder	8	17	168	168	185	200
SLD 8-5SV-HH	5/8 ODF Solder	8	17	168	168	185	200
SLD 8-6SV-HH	3/4 ODF Solder	8	17	168	168	185	200
SLD 8-7SV-HH	3/4 ODF Solder	8	17	168	168	185	200
SLD 13-5V-HH	5/8 SAE Flare	13.5	26	284	284	312	338
SLD 13-5SV-HH	5/8 ODF Solder	13.5	26	284	284	312	338
SLD 13-6SV-HH	3/4 ODF Solder	13.5	26	284	284	312	338
SLD 13-7SV-HH	7/8 ODF Solder	13.5	26	284	284	312	338
SLD 13-9SV-HH	1-1/8 ODF Solder	13.5	26	284	284	312	338
SLD 27-7SV-HH	7/8 ODF Solder	27	49	568	568	624	676
SLD 27-9SV-HH	1-1/8 ODF Solder	27	49	568	568	624	676
SLD 54-11SV-HH	1-3/8 ODF Solder	54	88	1136	1136	1248	1352
SLD 54-13SV-HH	1-5/8 ODF Solder	54	88	1136	1136	1248	1352

* 20 Drops = 1 Gram = 1 cc

Flow Capacity – Tons of Refrigeration

Refrigerant	R-22					R-134a					R-404A, R-507					R-407C					R-410A				
	40	20	0	-20	-40	40	20	0	-20	-40	40	20	0	-20	-40	40	20	0	-20	-40	40	20	0	-20	-40
Evaporator Temp °F	40	20	0	-20	-40	40	20	0	-20	-40	40	20	0	-20	-40	40	20	0	-20	-40	40	20	0	-20	-40
Pressure Drop PSI	3	2	1.5	1	0.5	2.0	1.5	1.0	0.5	3	2	1.5	1	0.5	3.0	3.0	2.0	1.5	1.0	0.5	3.0	2.0	1.5	1.0	0.5
SLD 8-3V-HH	1.1	0.8	0.6	0.4	0.2	0.7	0.6	0.5	0.4	1.0	0.7	0.5	0.3	0.2	1.1	0.8	0.6	0.4	0.2	1.4	0.6	0.5	0.3	0.1	
SLD 8-3SV-HH	1.2	0.9	0.7	0.5	0.3	0.8	0.7	0.6	0.5	1.1	0.8	0.6	0.4	0.2	1.2	0.9	0.7	0.5	0.3	1.5	0.7	0.5	0.4	0.2	
SLD 8-4V-HH	2.3	1.6	1.1	0.7	0.4	1.5	1.2	0.9	0.7	2.1	1.4	0.9	0.6	0.3	2.2	1.6	1.1	0.7	0.4	2.9	1.2	0.8	0.5	0.3	
SLD 8-4SV-HH	2.6	1.8	1.2	0.8	0.5	1.7	1.4	1.0	0.8	2.3	1.6	1.0	0.7	0.4	2.5	1.8	1.2	0.8	0.5	3.2	1.4	0.9	0.6	0.4	
SLD 8-5SV-HH	3.9	2.6	1.8	1.2	0.6	2.5	2.0	1.5	1.1	3.5	2.3	1.5	1.0	0.5	3.8	2.6	1.8	1.2	0.6	4.8	2.0	1.4	0.9	0.4	
SLD 8-6SV-HH	4.2	2.8	1.9	1.3	0.6	2.7	2.1	1.6	1.2	3.8	2.5	1.6	1.1	0.5	4.1	2.8	1.9	1.3	0.6	5.2	2.1	1.4	1.0	0.4	
SLD 8-7SV-HH	4.2	2.8	1.9	1.3	0.6	2.7	2.1	1.6	1.2	3.8	2.5	1.6	1.1	0.5	4.1	2.8	1.9	1.3	0.6	5.2	2.1	1.4	1.0	0.4	
SLD 13-5V-HH	4.2	2.8	2.0	1.3	0.8	2.7	2.1	1.7	1.2	3.8	2.5	1.7	1.1	0.6	4.0	2.7	2.0	1.3	0.8	5.1	2.1	1.5	1.0	0.6	
SLD 13-5SV-HH	5.0	3.0	2.5	1.5	1.0	3.2	2.3	2.1	1.4	4.5	2.7	2.1	1.2	0.8	4.9	3.0	2.5	1.5	1.0	6.2	2.3	1.9	1.1	0.7	
SLD 13-6SV-HH	7.0	4.5	3.0	2.0	1.0	4.5	3.4	2.5	1.9	6.3	4.0	2.6	1.7	0.8	6.8	4.5	3.0	2.0	1.0	8.7	3.4	2.3	1.5	0.7	
SLD 13-7SV-HH	7.0	4.5	3.0	2.0	1.0	4.5	3.4	2.5	1.9	6.3	4.0	2.6	1.7	0.8	6.8	4.5	3.0	2.0	1.0	8.7	3.4	2.3	1.5	0.7	
SLD 13-9SV-HH	7.2	4.6	3.1	2.1	1.0	4.6	3.5	2.6	2.0	6.4	4.1	2.6	1.7	0.8	7.0	4.6	3.1	2.1	1.0	8.9	3.5	2.3	1.6	0.7	
SLD 27-7SV-HH	10.0	8.0	5.0	3.0	2.0	6.4	6.0	4.2	2.9	8.9	7.2	4.3	2.5	1.6	9.7	7.9	5.0	3.1	2.1	12.4	6.1	3.8	2.2	1.5	
SLD 27-9SV-HH	13.0	9.0	6.0	4.0	2.0	8.3	6.8	5.1	3.8	11.6	8.1	5.1	3.3	1.6	12.7	8.3	6.0	4.1	2.1	16.1	6.9	4.5	3.0	1.5	
SLD 54-11SV-HH	20.0	13.5	9.5	6.5	3.5	12.8	10.2	8.0	6.2	17.9	12.1	8.1	5.4	2.8	19.5	13.4	9.5	6.6	3.6	24.8	10.3	7.2	4.8	2.6	
SLD 54-13SV-HH	23.0	16.0	11.0	7.0	4.0	14.7	12.1	9.3	6.7	20.6	14.3	9.4	5.8	3.2	22.4	15.8	11.1	7.1	4.1	28.5	12.2	8.3	5.2	2.9	

Flow Capacity – kW of Refrigeration

Refrigerant	R-22					R-134a					R-404A, R-507					R-407C					R-410A				
	4	-6	-18	-29	-40	4	-6	-18	-29	-40	4	-6	-18	-29	-40	4	-6	-18	-29	-40	4	-6	-18	-29	-40
Evaporator Temp °C	4	-6	-18	-29	-40	4	-6	-18	-29	-40	4	-6	-18	-29	-40	4	-6	-18	-29	-40	4	-6	-18	-29	-40
Pressure Drop Bar	0.21	0.14	0.11	0.07	0.04	0.14	0.11	0.07	0.04	0.21	0.14	0.11	0.07	0.04	0.21	0.21	0.14	0.11	0.07	0.04	0.21	0.14	0.11	0.07	0.04
SLD 8-3V-HH	3.9	2.8	2.1	1.4	0.7	2.5	2.1	1.8	1.4	3.5	2.5	1.8	1.1	0.7	3.9	2.8	2.1	1.4	0.7	4.9	2.1	1.8	1.1	0.4	
SLD 8-3SV-HH	4.2	3.2	2.5	1.8	1.1	2.8	2.5	2.1	1.8	3.9	2.8	2.1	1.4	0.7	4.2	3.2	2.5	1.8	1.1	5.3	2.5	1.8	1.4	0.7	
SLD 8-4V-HH	8.1	5.6	3.9	2.5	1.4	5.3	4.2	3.2	2.5	7.4	4.9	3.2	2.1	1.1	7.7	5.6	3.9	2.5	1.4	10.2	4.2	2.8	1.8	1.1	
SLD 8-4SV-HH	9.1	6.3	4.2	2.8	1.8	6.0	4.9	3.5	2.8	8.1	5.6	3.5	2.5	1.4	8.8	6.3	4.2	2.8	1.8	11.2	4.9	3.2	2.1	1.4	
SLD 8-5SV-HH	13.7	9.1	6.3	4.2	2.1	8.8	7.0	5.3	3.9	12.3	8.1	5.3	3.5	1.8	13.3	9.1	6.3	4.2	2.1	16.8	7.0	4.9	3.2	1.4	
SLD 8-6SV-HH	14.7	9.8	6.7	4.6	2.1	9.5	7.4	5.6	4.2	13.3	8.8	5.6	3.9	1.8	14.4	9.8	6.7	4.6	2.1	18.2	7.4	4.9	3.5	1.4	
SLD 8-7SV-HH	14.7	9.8	6.7	4.6	2.1	9.5	7.4	5.6	4.2	13.3	8.8	6.0	3.9	2.1	14.0	9.5	7.0	4.6	2.8	17.9	7.4	5.3	3.5	2.1	
SLD 13-5V-HH	14.8	9.9	7.0	4.6	2.8	9.5	7.4	6.0	4.2	13.4	8.8	6.0	3.9	2.1	14.1	9.5	7.0	4.6	2.8	17.9	7.4	5.3	3.5	2.1	
SLD 13-5SV-HH	17.6	10.6	8.8	5.3	3.5	11.3	8.1	7.4	4.9	15.8	9.5	7.4	4.2	2.8	17.2	10.6	8.8	5.3	3.5	21.8	8.1	6.7	3.9	2.5	
SLD 13-6SV-HH	24.5	15.8	10.5	7.0	3.5	15.8	11.9	8.8	6.7	22.1	14.0	9.1	6.0	2.8	23.8	15.8	10.5	7.0	3.5	30.5	11.9	8.1	5.3	2.5	
SLD 13-7SV-HH	24.5	15.8	10.5	7.0	3.5	15.8	11.9	8.8	6.7	22.1	14.0	9.1	6.0	2.8	23.8	15.8	10.5	7.0	3.5	30.5	11.9	8.1	5.3	2.5	
SLD 13-9SV-HH	25.2	16.2	10.9	7.4	3.5	16.1	12.3	9.1	7.0	22.4	14.4	9.1	6.0	2.8	24.5	16.1	10.9	7.4	3.5	31.2	12.3	8.1	5.6	2.5	
SLD 27-7SV-HH	35.0	28.0	17.5	10.5	7.0	22.4	21.0	14.7	10.2	31.2	25.2	15.1	8.8	5.6	34.1	27.7	17.5	10.9	7.4	43.4	21.4	13.3	7.7	5.3	
SLD 27-9SV-HH	45.5	31.5	21.0	14.0	7.0	29.1	23.8	17.9	13.3	40.6	28.4	17.9	11.6	5.6	44.5	29.1	21.0	14.4	7.4	56.4	24.2	15.8	10.5	5.3	
SLD 54-11SV-HH	70.0	47.3	33.3	22.8	12.3	44.8	35.7	28.0	21.7	62.7	42.4	28.4	18.9	9.8	68.3	46.9	33.3	23.1	12.6	86.8	36.1	25.2	16.8	9.1	
SLD 54-13SV-HH	80.5	56.0	38.5	24.5	14.0	51.5	42.3	32.6	23.5	72.1	56.0	32.5	26.3	11.2	78.4	55.3	38.9	24.9	14.4	94.8	42.7	29.1	18.2	10.2	

Sahara Series™ Suction Line Filter-Driers

The Sahara Series suction line filter-driers complement Parker’s SLD Series suction line filter-driers by offering a standard size alternative for air conditioning applications. The Sahara products provide the required protection as a service filter-drier for handling the contaminant removal requirements associated with these systems. The Sahara Series includes a desiccant blend formulation to handle moisture and acids while the internal assembly provides the filtering to remove harmful particles in circulation.



For other applications or air conditioning systems where uniquely higher capacities are desired, the Parker Gold Label SLD molded core suction line filter-driers are suggested.

Features and Benefits

- Service filter-drier for air conditioning systems
- Desiccant blend suited for acid and moisture removal
- Copper fittings for easy installation
- Access port for checking system pressure drop
- Corrosion resistant black powder coating surpasses 500-hour ASTM salt spray testing
- Compatible with commercially available refrigerants

Sahara Series Suction Line Filter-Drier Dimensions

Model No.	Fitting Type (Inches)	Length (Inches)		Diameter (Inches)	
		Inches	mm	Inches	mm
SLD165-V	5/8 ODF Solder	6.31	160	2.38	60.5
SLD166-V	3/4 ODF Solder	6.37	162	2.38	60.5
SLD167-V	7/8 ODF Solder	6.37	162	2.38	60.5
SLD305-V	5/8 ODF Solder	9.25	235	3.00	76.2
SLD306-V	3/4 ODF Solder	9.31	236	3.00	76.2
SLD307-V	7/8 ODF Solder	9.31	236	3.00	76.2

Sahara Series Suction Line Filter-Drier Flow Capacity

(Tons (kW) of Refrigeration at 40°F (4.4°C) Evaporator Temperature and 3 PSI (.21 bar) Pressure Drop)

Model No.	R-22		R-134a		R-407C		R-410A	
	Tons	kW	Tons	kW	Tons	kW	Tons	kW
SLD165-V	2.7	9.5	2.0	7.0	2.6	9.1	3.2	11.3
SLD166-V	3.2	11.3	2.5	8.8	3.1	10.9	3.8	13.4
SLD167-V	3.4	12	2.6	9.1	3.3	11.6	4.1	14.4
SLD305-V	3.4	12	2.2	7.7	3.3	11.6	4.1	14.4
SLD306-V	4.4	15.5	2.8	9.9	4.3	15.1	5.3	18.6
SLD307-V	4.6	16.2	3.0	10.6	4.5	15.8	5.5	19.3

Replaceable Core Shells

Parker replaceable core shells are designed to provide flexibility over a wide range of applications. All models are designed for use in both the liquid and suction line of air conditioning or refrigeration systems. In single or multiple-core applications, cores may be loaded individually for ease of installation in tight spots. A wide range of fittings for suction-line applications and interchangeable lay-in dimensions with other manufactured models increase product versatility.

The internal assembly allows the use of Parker's Z-48, PCX-48, PCK-48 or PCK-48HH molded cores for the removal of moisture, acid, particles, resins and wax. The assembly allows the use of the Parker PFE-48BF filter element which removes solid contaminants such as copper oxides, chips and other metal fines.



Features and Benefits

- ODF Solder fittings – 5/8" to 3-1/8"
- Powder paint exterior coating surpasses 500 hour ASTM salt spray test to resist corrosion
- Aluminum end plate with access port
- Rated 650 psig (44.8 bar) for R-410A

Replaceable Core Shell Dimensions

Shell	No. of Cores	Connection Size & Type (Inches)	Dimensions – Inches (mm)											
			A		B		C		D		E		F	
			Inches	mm	Inches	mm	Inches	mm	Inches	mm	Inches	mm	Inches	mm
P485	1	5/8 ODF	9.15	232	6.00	152	5.00	127	5.92	150	3.50	88.9	4.75	121
P487	1	7/8 ODF	9.30	236	6.00	152	5.00	127	6.07	154	3.72	94.5	4.75	121
P489	1	1-1/8 ODF	9.50	241	6.00	152	5.00	127	6.37	162	3.78	96	4.75	121
P4811	1	1-3/8 ODF	9.60	244	6.00	152	5.00	127	6.37	162	3.94	100	4.75	121
P4813	1	1-5/8 ODF	9.60	244	6.00	152	5.00	127	6.37	162	3.97	101	4.75	121
P4817	1	2-1/8 ODF	9.60	244	6.00	152	5.00	127	5.58	142	4.41	112	4.75	121
P4821	1	2-5/8 ODF	9.60	244	6.00	152	5.00	127	5.75	146	5.19	132	4.75	121
P967	2	7/8 ODF	14.84	377	6.00	152	5.00	127	11.61	295	3.72	94.5	4.75	121
P969	2	1-1/8 ODF	15.04	382	6.00	152	5.00	127	11.81	300	3.78	96	4.75	121
P9611	2	1-3/8 ODF	15.14	385	6.00	152	5.00	127	11.91	303	3.94	100	4.75	121
P9613	2	1-5/8 ODF	15.14	385	6.00	152	5.00	127	11.91	303	3.97	101	4.75	121
P9617	2	2-1/8 ODF	15.14	385	6.00	152	5.00	127	11.35	288	4.41	112	4.75	121
P9621	2	2-5/8 ODF	15.14	385	6.00	152	5.00	127	11.10	282	5.19	132	4.75	121
P9625	2	3-1/8 ODF	15.14	385	6.00	152	5.00	127	10.78	274	4.90	124	4.75	121
P1449	3	1-1/8 ODF	20.58	523	6.00	152	5.00	127	17.35	441	3.78	96	4.75	121
P14411	3	1-3/8 ODF	20.68	525	6.00	152	5.00	127	17.45	443	3.94	100	4.75	121
P14413	3	2-1/8 ODF	20.68	525	6.00	152	5.00	127	17.45	443	3.97	101	4.75	121
P19211	4	1-3/8 ODF	26.22	666	6.00	152	5.00	127	22.99	584	3.94	100	4.75	121
P19213	4	1-5/8 ODF	26.22	666	6.00	152	5.00	127	22.99	584	3.97	101	4.75	121
P19217	4	2-1/8 ODF	26.22	666	6.00	152	5.00	127	22.43	570	4.65	118	4.75	121

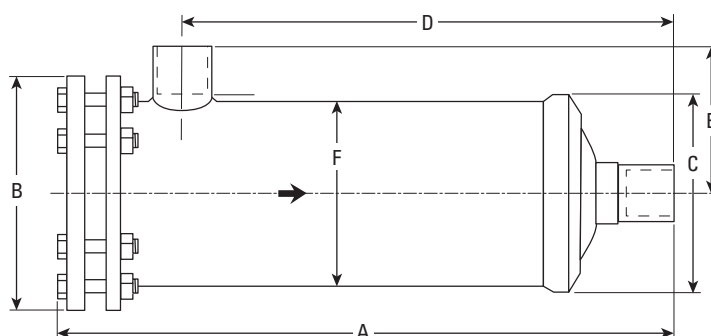

Replacement Filter Element and Cores

Z-48 Super High Capacity Core

Recommended for use with POE lubricants. The Z-48 has three times the moisture capacity of standard cores to handle the water-absorbing tendencies of POE lubricants. Should be used in applications where there are elevated levels of moisture. For use in the liquid or suction line.



PCX-48 High Capacity Gold Label Core

For use in either liquid or suction line applications, the PCX-48 offers added moisture capacity and good acid capacity when compared to the PCK-48 core.



PCK-48 Clean-up Core

For use in either liquid or suction line applications, the PCK-48 is specifically formulated for burnouts where wax is not the issue. It's formulation allows for superior clean-up of acids, varnishes, sludge and moisture.



PCK-48HH Charcoal Burnout Core

Formulated with charcoal to remove wax on low temperature systems even before problems occur. The PCK-48HH can be used in either liquid or suction line applications and also removes acids, water, solids and sludge. Recommended for refrigerant reclaim/recovery units.



PFE-48BF Parker Filter Element

For use in filtering out solid contaminants. Suitable for bi-directional applications, this filter features low pressure drop and filtration capabilities down to 20 microns. It is also interchangeable with other manufacturers' filters.



Replacement Filter Element and Cores

Water Capacity In Drops (Grams*) at ARI-710 Conditions

Core Model	R-22 (60 ppm)		R-134a (50 ppm)		R-404A, R-507A (50 ppm)		R-407C (50 ppm)	
	75°F (24°C)	125°F (52°C)	75°F (24°C)	125°F (52°C)	75°F (24°C)	125°F (52°C)	75°F (24°C)	125°F (52°C)
PCX-48	697	524	762	591	766	584	534	392
PCK-48HH	474	322	518	363	521	359	363	241
PCK-48	549	386	600	435	604	430	420	288
Z-48	1659	1433	1814	1614	1823	1596	1270	1070

* 20 Drops = 1 Gram = 1 cc

Liquid Line Selection Recommendations – Tons (kW)

Shell	No. of Cores	Connection Size and Type	Refrigeration Low Temp. & Commercial Installations		Air Conditioning																	
					Field Replacement & Field Installations						OEM / Self Contained Equipment											
					R-134a		R-22		R-404A, R-507		R-134a		R-22, R-407C R-410A		R-404A, R-507		R-134a		R-22, R-407C R-410A		R-404A R-507	
					Tons	kW	Tons	kW	Tons	kW	Tons	kW	Tons	kW	Tons	kW	Tons	kW	Tons	kW	Tons	kW
P485	1	5/8 ODF	8	28.1	10	35.2	8	28.1	8	28.1	10	35.2	8	28.1	10	35.2	15	52.8	10	35.2		
P487	1	7/8 ODF	12	42.2	15	52.8	10	35.2	11	38.7	14	49.2	10	35.2	13	45.7	20	70.3	13	45.7		
P489	1	1-1/8 ODF	12	42.2	15	52.8	10	35.2	13	45.7	17	59.8	10	35.2	15	52.8	25	87.9	15	52.8		
P4811	1	1-3/8 ODF	13	45.7	20	70.3	13	45.7	13	45.7	20	70.3	13	45.7	15	52.8	25	87.9	15	52.8		
P4813	1	1-5/8 ODF	15	52.8	20	70.3	15	52.8	15	52.8	20	70.3	15	52.8	20	70.3	27	95	20	70.3		
P4817	1	2-1/8 ODF	20	70.3	25	87.9	20	70.3	20	70.3	25	87.9	20	70.3	22	77.4	30	106	22	77.4		
P4821	1	2-5/8 ODF	20	70.3	25	87.9	20	70.3	20	70.3	25	87.9	20	70.3	22	77.4	30	106	22	77.4		
P967	2	7/8 ODF	20	70.3	25	87.9	15	52.8	20	70.3	25	87.9	15	52.8	20	70.3	35	123	20	70.3		
P969	2	1-1/8 ODF	25	87.9	35	123	20	70.3	25	87.9	33	116	20	70.3	25	87.9	40	141	25	87.9		
P9611	2	1-3/8 ODF	30	106	35	123	25	87.9	30	106	35	123	25	87.9	30	106	45	158	30	106		
P9613	2	1-5/8 ODF	35	123	40	141	30	106	35	123	40	141	30	106	35	123	50	176	35	123		
P9617	2	2-1/8 ODF	40	141	45	158	35	123	40	141	45	158	35	123	40	141	55	193	40	141		
P9621	2	2-5/8 ODF	40	141	45	158	35	123	40	141	45	158	35	123	40	141	55	193	40	141		
P9625	2	3-1/8 ODF	45	158	50	176	40	141	45	158	50	176	40	141	45	158	60	211	45	158		
P1449	3	1-1/8 ODF	30	106	40	141	30	106	30	106	40	141	30	106	35	123	55	193	35	123		
P14411	3	1-3/8 ODF	40	141	50	176	35	123	40	141	50	176	35	123	40	141	65	229	40	141		
P14413	3	1-5/8 ODF	50	176	50	176	40	141	45	158	55	193	40	141	45	158	70	246	45	158		
P14417	3	2-1/8 ODF	60	211	50	176	45	158	50	176	60	211	45	158	50	176	80	281	50	176		
P19211	4	1-3/8 ODF	50	176	70	246	45	158	50	176	70	246	45	158	50	176	80	281	50	176		
P19213	4	1-5/8 ODF	60	211	80	281	55	193	60	211	80	281	55	193	60	211	100	352	60	211		
P19217	4	2-1/8 ODF	65	229	85	299	60	211	65	229	85	299	60	211	65	229	100	352	65	229		

Suction Line Selection Recommendations – Horsepower (kW)

Shell	No. of Cores	Connection Size and Type	Core Part Number	Filter Element Part No.	Refrigerant 22 & 407C				Refrigerant 12, 134a, 404A, 502, 507			
					Permanent Installation with Cores		Temporary Installation Cores for cleanup; Filter elements after cleanup		Permanent Installation with Cores		Temporary Installation Cores for cleanup; Filter elements after cleanup	
					HP	kW	HP	kW	HP	kW	HP	kW
P485	1	5/8 ODF	PCK-48HH or PCK-48	PFE-48BF	10	7.5	10	7.5	3	2.2	5	3.7
P487	1	7/8 ODF			10	7.5	10	7.5	3	2.2	5	3.7
P489	1	1-1/8 ODF			10	7.5	20	14.9	5	3.7	10	7.5
P4811	1	1-3/8 ODF			10	7.5	20	14.9	5	3.7	10	7.5
P4813	1	1-5/8 ODF			10	7.5	20	14.9	5	3.7	10	7.5
P967	2	7/8 ODF			10	7.5	10	7.5	5	3.7	5	3.7
P969	2	1-1/8 ODF			15	11.2	20	14.9	8	6.0	10	7.5
P9611	2	1-3/8 ODF			20	14.9	30	22.4	10	7.5	15	11.2
P9613	2	1-5/8 ODF			20	14.9	30	22.4	10	7.5	15	11.2
P1449	3	1-1/8 ODF			15	11.2	20	14.9	7-1/2	5.6	10	7.5
P14411	3	1-3/8 ODF			25	18.6	35	26.1	12	9.0	15	11.2
P14413	3	1-5/8 ODF			25	18.6	35	26.1	12	9.0	15	11.2
P19211	4	1-3/8 ODF			25	18.6	40	29.8	12	9.0	20	14.9
P19213	4	1-5/8 ODF			25	18.6	40	29.8	12	9.0	20	14.9
P19217	4	2-1/8 ODF			25	18.6	40	29.8	12	9.0	20	14.9

Filters and Pre-Filters

Parker provides a large selection of components for recovery, recycle and reclaim machines, protecting them from the many types of contaminants that are encountered during the servicing of systems.

PF Series

The PF 052 and PF 052MF are designed to provide a filtration level of 15 microns. When installed on the inlet of your machine it can prevent costly damage by filtering solid contaminants out of the refrigerant before it enters your machine. The Parker pre-filter is for temporary use only and should be changed after servicing a maximum of six to eight systems. Change out may be needed sooner depending on actual system conditions. Various fitting combinations are available.



Features and Benefits

- Female outlet fitting allows direct mounting to the machine
- Extended female end fitting provides valve handle clearance
- Male-to-male fittings allow connection to, or between, hoses
- Enlarged depth filtering area
- UL listed

Dimensions

Model	Inlet Fitting (Inches)	Outlet Fitting (Inches)	Overall Length		Shell Diameter	
			Inches	mm	Inches	mm
PF 052	1/4 SAE male flare	1/4 SAE male flare	4.38	111	2.38	60.5
PF 052MF	1/4 SAE male flare	1/4 SAE female flare	5.02	128	2.38	60.5

SPD Series

The SPD series is an enlarged version of the PF Series with drying capabilities. This Super Pre-Filter-Drier should be installed at the inlet of the machine and used where there are concentrations of contaminants in the refrigerant. Moisture capacity of this unit size exceeds anything else currently available in the market. The Super SPD series is the ideal solution when transferring large amounts of refrigerant for reclaim or recycle.



Features and Benefits

- Super high capacity for acid and moisture removal
- Removes 504 (25.2 grams) drops of moisture vs. industry standard of 150 (7.5 grams) drops
- Available with either 1/4" SAE or 3/8" SAE flare connections
- Compatible with all HCFC, CFC and other refrigerants and blends

Dimensions

Model	Inlet Fitting (Inches)	Outlet Fitting (Inches)	Overall Length		Shell Diameter	
			Inches	mm	Inches	mm
SPD-162	1/4 SAE male flare	1/4 SAE male flare	8.00	203	2.50	63.5
SPD-162MF	1/4 SAE male flare	1/4 SAE female flare	8.64	219	2.50	63.5
SPD-163	3/8 SAE male flare	3/8 SAE male flare	8.44	214	2.50	63.5
302V	1/4 SAE male flare	1/4 SAE male flare	9.28	236	3.00	76.2
304V	1/2 ACME	1/2 ACME	9.28	236	3.00	76.2

The 302V and 304V are slightly bigger shells when compared to the SPD for additional water capacity.

Oil Vapor Drier Separator and Steel Muffler

Oil Vapor Drier Separator

The Parker Vapor Drier Separator (VDS Series) removes contaminated oil from a system in addition to solids, acid and moisture. A 1/4" SAE oil drain access fitting is located on the bottom to provide a continuous means of measuring the amount of oil removed from a system, thereby indicating the amount needed to be replaced. The VDS holds up to four ounces of oil and is reusable for up to 50 pounds (22.7 kg) of refrigerant, depending upon contamination levels. For rigid or secure mounting, a side bracket is welded to the body. The VDS can also be hung from a manifold gauge set with the wire strap provided. A model is available with coalescing element for improved oil separation.



Features and Benefits

- Oil removal drain fitting
- Acid and moisture removal
- 3/8" SAE male flare fittings
- Inlet access valve fitting
- Mounting bracket

Dimensions

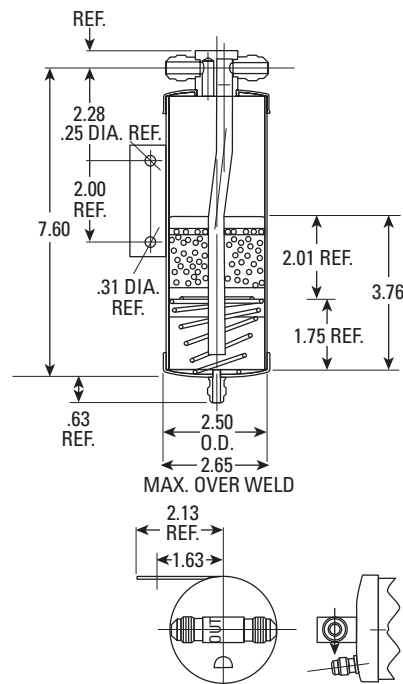

Steel Muffler

Parker's aftermarket steel muffler (P/N: PM3083-5-4C) is designed to assist with compressor related difficulties, such as noise reduction due to compressor pulsation and/or turbulent gas flow or vibration through the discharge line.

Features

- UL/CSA listed for 600 psig (41.4 bar) design pressure for R-410A
- 1/2 ODF Solder
- Fully welded construction
- Bi-directional flow
- Powder coated paint gives maximum corrosion resistance of 500 hour salt spray protection
- Muffler utilizes 3.0 inch (76.2 mm) diameter shell and is 9.13 inches (232 mm) in length

Granular Copper Filter-Driers – OEM

Parker’s granular copper filter-driers adsorb moisture and provide physical filtration in systems between 1/4 and 2 tons (.9 to 7.0 kW). Applications include refrigerators, freezers, ice makers, dispensers, water coolers, cryogenics and walk-ins.

Applications

Refrigeration systems between 1/4 and 2 tons (.9 to 7.0 kW)

installation, simple brazing, and corrosion resistance

Up to 30 grams of 100% molecular sieve provide maximum water adsorption

Features and Benefits

One-piece copper shells in 3/4" to 1" O.D. (19.1 to 25.4 mm), spun ODF solder connections in a variety of sizes, provide easy

Filter-driers also available with standard charging tubes, SAE flare fittings, stepped-tubes on the inlet/outlet, and coiled capillary or bent tubing to match the unique requirements of a unit



3/4" O.D. Shell Diameter – Specifications

Part No.	Maximum Rated Pressure		Inlet (Inches)	Outlet (Inches)	Overall Length	
	PSIG*	bar			Inches	mm
032099-00	360	24.8	.164 .159/.258 .253	.091 .086	4.63	118
032159-00	360	24.8	.164 .159	.091 .086	4.50	114
032200-00	500	34.5	.195 .190	.081 .076	4.37	111
032169-00	360	24.8	.197 .192	.092 .087	4.75	121

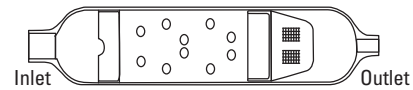

Recommended tonnages: 1/4 to 2 tons (.9 to 7.0 kW) depending on application and system. Consult Parker.

* Filter-driers are available with higher working pressures for R-410A.

3/4" O.D. Shell Diameter – Water Capacity In Drops (Grams*) at ARI-710 Conditions

Part No.	Water Capacity in Drops									
	R-22 (60 ppm)		R-134a (50 ppm)		R-404A, R-507 (50 ppm)		R-407C (50 ppm)		R-410A (50 ppm)	
	75°F (24°C)	125°F (52°C)	75°F (24°C)	125°F (52°C)	75°F (24°C)	125°F (52°C)	75°F (24°C)	125°F (52°C)	75°F (24°C)	125°F (52°C)
032099-00	29.8	27.4	32.6	31.0	32.8	30.6	26.2	23.6	19.8	17.4
032159-00	29.8	27.4	32.6	31.0	32.8	30.6	26.2	23.6	19.8	17.4
032200-00	25.3	23.3	27.7	26.4	27.9	26.0	22.3	20.1	16.8	14.8
032169-00	29.8	27.4	32.6	31.0	32.8	30.6	26.2	23.6	19.8	17.4

One and two inlets are available as well as cap tube sizes on outlet from .081 to .125.

* 20 Drops = 1 Gram = 1 cc

1" O.D. Shell Diameter Copper Filter-Drier Data

Part No.	Maximum Rated Pressure		Inlet (Inches)	Outlet (Inches)	Overall Length	
	PSIG*	bar			Inches	mm
032083-00	500	34.5	.250 .244	.098 .093	4.00	102
058066-00	500	34.5	.380 .377/.256 .253	.195 .190	4.19	106
057404-00	500	34.5	.320 .315	.320 .315	3.81	97

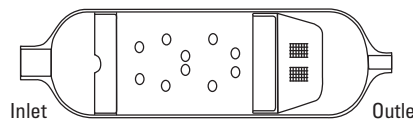

Recommended tonnages (part numbers 032083-00 and 058066-00): 1/4 to 1/2 tons (.9 to 1.8 kW) depending on application and system. Consult Parker.

Recommended tonnages (part number 057404-00):
 R-22 = 2 (7.0 kW) R-134a = 2 (7.0 kW)
 R-404A = 1.3 (4.6 kW) R-410A = 2 (7.0 kW)
 R-507 = 1.3 (4.6 kW)

* Filter-driers are available with higher working pressures for R-410A.

1" O.D. Shell Diameter – Water Capacity In Drops (Grams*) at ARI-710 Conditions

Part No.	Water Capacity in Drops									
	R-22 (60 ppm)		R-134a (50 ppm)		R-404A, R-507 (50 ppm)		R-407C (50 ppm)		R-410A (50 ppm)	
	75°F (24°C)	125°F (52°C)	75°F (24°C)	125°F (52°C)	75°F (24°C)	125°F (52°C)	75°F (24°C)	125°F (52°C)	75°F (24°C)	125°F (52°C)
032083-00	N/R	N/R	40.3	37.7	N/R	N/R	N/R	N/R	N/R	N/R
058066-00	44.7	41.1	48.9	46.5	49.2	45.9	39.3	35.4	29.7	26.1
057404-00	54.7	50.6	59.8	57.0	59.5	56.0	41.9	37.8	32.3	28.8

N/R = not recommended. Consult Parker for more information.

* 20 Drops = 1 Gram = 1 cc

Spring-Loaded Copper Filter-Driers – OEM

Parker’s spring-loaded granular copper filter-driers adsorb moisture and provide physical filtration to air conditioning and heat-pump systems between 1/4 and 5 tons (.9 and 17.6 kW). Filter-driers utilize spring-loaded desiccant bed to prevent desiccant attrition.

Application

- Air conditioning and heat pump systems between 1/4 and 5 tons (.9 and 17.6 kW)

Features and Benefits

- One-piece copper shells in 1" to 1-5/8" O.D. (25.4 to 41.3 mm), along with spun ODF solder fittings in a variety of sizes, provide easy installation, simplified brazing and corrosion resistance

- Up to 90 grams of 100% molecular sieve provide maximum water adsorption
- Filter-driers also available with standard charging tubes, SAE flare fittings, stepped-tubes on the inlet/outlet, and coiled capillary or bent tubing to match the unique requirements of a unit
- Filter-driers are available with a fiberglass pad for improved filtration – removes down to 20 micron sized particles



1" O.D. Shell Diameter – Specifications

Part No.	Maximum Rated Pressure		Inlet (Inches)	Outlet (Inches)	Overall Length	
	PSIG*	bar			Inches	mm
032231-00	500	34.5	.202 .192/.381 .378	.133 .128	4.25	108
054625-01	500	34.5	.256 .253	.256 .253	4.38	111
056242-03	500	34.5	.383 .378	.383 .378	4.38	111
053817-01	500	34.5	.378 .383	.378 .383	5.69	145

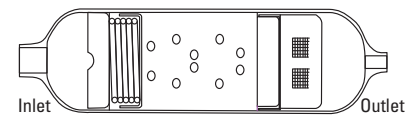

* Filter-driers are available with higher working pressures for R-410A.

Flow Capacity – Tons @ 1psi ΔP (kW @ 0.07 bar ΔP)

Part No.	R-22		R-134a		R-404A		R-407C		R-410A		R-507	
	Tons	kW	Tons	kW	Tons	kW	Tons	kW	Tons	kW	Tons	kW
032231-00	Recommended Tonnages: 1/2 to 1 tons (1.8 to 3.5 kW) depending on application and system. Consult Parker.											
054625-01	1.5	5.3	1.6	5.6	1.2	4.2	1.4	4.9	1.7	6.0	1.2	4.2
056242-03	3.6	12.7	3.3	11.6	2.4	8.4	3.5	12.3	3.5	12.3	2.3	8.1
053817-01	3	10.6	2.7	9.5	2	7.0	2.9	10.2	2.9	10.2	2	7.0

1" O.D. Shell Diameter – Water Capacity In Drops (Grams*) at ARI-710 Conditions

Part No.	Water Capacity in Drops									
	R-22 (60 ppm)		R-134a (50 ppm)		R-404A, R-507 (50 ppm)		R-407C (50 ppm)		R-410A (50 ppm)	
	75°F (24°C)	125°F (52°C)	75°F (24°C)	125°F (52°C)	75°F (24°C)	125°F (52°C)	75°F (24°C)	125°F (52°C)	75°F (24°C)	125°F (52°C)
032231-00	29.8	27.4	32.6	31.0	32.8	30.6	26.2	23.6	19.8	17.4
054625-01	46.2	42.7	50.5	48.1	50.2	47.3	49.4	44.8	27.3	24.3
056242-03	46.2	42.7	50.5	48.1	50.2	47.3	49.4	44.8	27.3	24.3
053817-01	85.5	79.0	93.5	89.0	93.0	87.5	91.5	83.0	50.5	45.0

One and two inlets are available as well as cap tube sizes on outlet from .125 to .50. All 1" (25.4 mm) filter-driers are U.L. recognized components, File #SA8570. Tonnage (kW) ratings will vary depending on the inlet and outlet requested.

* 20 Drops = 1 Gram = 1 cc

Spring-Loaded Copper Filter-Driers – OEM

1-3/16" O.D. Shell Diameter – Specifications

Part No.	Maximum Rated Pressure		Inlet (Inches)	Outlet (Inches)	Overall Length	
	PSIG*	bar			Inches	mm
056243-04	500	34.5	.508 .503	.508 .503	5.13	130
056243-03	500	34.5	.383 .378	.383 .378	5.13	130
053776-00	540	37.2	.384 .378	.384 .378	7.00	178

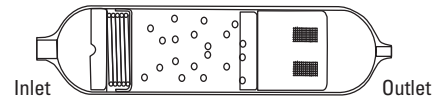

* Filter-driers are available with higher working pressures for R-410A.

Flow Capacity – Tons @ 1psi ΔP (kW @ 0.07 bar ΔP)

Part No.	R-22		R-134a		R-404A, R-507		R-407C		R-410A		R-507	
	Tons	kW	Tons	kW	Tons	kW	Tons	kW	Tons	kW	Tons	kW
056243-04	4.8	16.9	4.4	15.5	3.1	10.9	4.6	16.2	4.7	16.5	3.1	10.9
056243-03	3.6	12.7	3.3	11.6	2.3	8.1	3.5	12.3	3.5	12.3	2.3	8.1
053776-00	3.7	13	3.4	12	2.4	8.4	3.6	12.7	3.6	12.7	2.4	8.4

1-3/16" O.D. Shell Diameter – Water Capacity In Drops (Grams*) at ARI-710 Conditions

Part No.	Water Capacity in Drops									
	R-22 (60 ppm)		R-134a (50 ppm)		R-404A, R-507 (50 ppm)		R-407C (50 ppm)		R-410A (50 ppm)	
	75°F (24°C)	125°F (52°C)	75°F (24°C)	125°F (52°C)	75°F (24°C)	125°F (52°C)	75°F (24°C)	125°F (52°C)	75°F (24°C)	125°F (52°C)
056243-04	85.5	79.0	93.5	89.0	93.0	87.5	65.5	59.0	50.5	45.0
056243-03	85.5	79.0	93.5	89.0	93.0	87.5	65.5	59.0	50.5	45.0
053776-00	153.9	142.2	168.3	160.2	167.4	157.5	117.9	106.2	90.9	81.0

One and two inlets are available as well as cap tube sizes on outlet from .125 to .50. All 1-3/16" (30.2 mm) driers are U.L. recognized components, File #SA8570. Tonnage (kW) ratings will vary depending on the inlet and outlet requested.

* 20 Drops = 1 Gram = 1 cc

1-5/8" O.D. Shell Diameter – Specifications

Part No.	Maximum Rated Pressure		Inlet (Inches)	Outlet (Inches)	Overall Length	
	PSIG*	bar			Inches	mm
032040-00	500	34.5	.383 .378	.383 .378	6.00	152
032145-00	500	34.5	.383 .378	.383 .378	4.38	111
031805-03	500	34.5	.383 .378	.383 .378	5.50	140
056244-01	500	34.5	.383 .378	.383 .378	5.38	137
056156-01	500	34.5	.253 .256	.253 .256	7.00	178

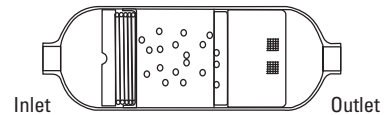

* Filter-driers are available with higher design pressures for R-410A.

Flow Capacity – Tons @ 1psi ΔP (kW @ 0.07 bar ΔP)

Part No.	R-22		R-134a		R-404A, R-507		R-407C		R-410A		R-507	
	Tons	kW	Tons	kW	Tons	kW	Tons	kW	Tons	kW	Tons	kW
032040-00	5.8	20.4	5.3	18.6	3.8	13.4	5.6	19.7	5.7	20	3.8	13.4
032145-00	4.7	16.5	4.3	15.1	3.1	10.9	4.5	15.8	4.6	16.2	3.1	10.9
031805-03	5.1	17.9	4.7	16.5	3.3	11.6	4.9	17.2	5	17.6	3.3	11.6
056244-01	5	17.6	4.5	15.8	3.2	11.3	4.8	16.9	4.8	16.9	3.2	11.3
056156-01	1.8	6.3	1.6	5.6	1.2	4.2	1.7	6.0	1.7	6.0	1.2	4.2

Spring-Loaded Copper Filter-Driers – OEM

1-5/8" O.D. Shell Diameter – Water Capacity In Drops (Grams*) at ARI-710 Conditions

Part No.	Water Capacity in Drops									
	R-22 (60 ppm)		R-134a (50 ppm)		R-404A, R-507 (50 ppm)		R-407C (50 ppm)		R-410A (50 ppm)	
	75°F (24°C)	125°F (52°C)	75°F (24°C)	125°F (52°C)	75°F (24°C)	125°F (52°C)	75°F (24°C)	125°F (52°C)	75°F (24°C)	125°F (52°C)
032040-00	153.9	142.2	168.3	160.2	167.4	157.5	117.9	106.2	90.9	81.0
032145-00	83.4	76.7	91.3	86.8	91.8	85.7	73.4	66.1	55.4	48.7
031805-03	119.7	110.6	130.9	124.6	130.2	122.5	91.7	82.6	70.7	63.0
056244-01	153.9	142.2	168.3	160.2	167.4	157.5	117.9	106.2	90.9	81.0
056156-01	307.8	284.4	336.6	320.4	334.8	315.0	235.8	212.4	181.8	162.0

One and two inlets are available as well as cap tube sizes on outlet from .125 to .50. All 1-3/16" (30.2 mm) driers are U.L. recognized components, File #SA8570. Tonnage (kW) ratings will vary depending on the inlet and outlet requested.

* 20 Drops = 1 Gram = 1 cc

CBF Bi-Flow Copper Filter-Driers – OEM

Parker's bi-flow copper filter-driers provide system protection of contaminants for heat-pumps between 1-1/2 and 4-1/2 tons (5.3 and 15.8 kW).

Application

- Heat pump systems between 1-1/2 and 4-1/2 tons (5.3 and 15.8 kW)

Features and Benefits

- One-piece copper shell with 2" (51mm) O.D., along with spun ODF fittings in a variety of sizes, provides easy installation
- 100% molecular sieve molded core for maximum water capacity
- Copper construction offers excellent corrosion resistance in harsh environments



Base Product Part Number

- CBF

Copper Bi-Flow Filter-Drier – Dimensions

Part No.	Fitting Type (Inches)	Overall Length		Shell Diameter	
		Inches	mm	Inches	mm
032284-052	1/4 ODF Solder	7.04	179	2.00	51
032284-053	3/8 ODF Solder	7.04	179	2.00	51
032284-082	1/4 ODF Solder	7.98	203	2.00	51
032284-083	3/8 ODF Solder	7.98	203	2.00	51
032284-084	1/2 ODF Solder	7.98	203	2.00	51
032284-085	5/8 ODF Solder	7.98	203	2.00	51

All of these driers have a .01 - .02 tube stop in the inlet and outlet.

Liquid Capacity in Ounces (Grams) @ 100°F (38°C)

Part No. Series	R-22		R-134a		R-404A, R-507		R-407C		R-410A	
	Ounces	grams	Ounces	grams	Ounces	grams	Ounces	grams	Ounces	grams
032284-050	6.47	183	6.55	186	5.55	157	6.12	173	5.64	160
032284-080	8.18	232	8.28	235	7.02	199	7.73	219	7.13	202

Water Capacity In Drops (Grams*) at ARI-710 Conditions

Part No. Series	R-22 (60 ppm)		R-134a (50 ppm)		R-404A, R-507 (50 ppm)		R-407C (50 ppm)		R-410A (50 ppm)	
	75°F (24°C)	125°F (52°C)	75°F (24°C)	125°F (52°C)	75°F (24°C)	125°F (52°C)	75°F (24°C)	125°F (52°C)	75°F (24°C)	125°F (52°C)
032284-050	129	112	141	127	141	124	101	84	81	64
032284-080	207	180	226	202	225	199	161	134	129	102

* 20 Drops = 1 Gram = 1 cc



CLIMATE CONTROL

- Accumulators
- CO₂ controls
- Electronic controllers
- Filter-driers
- Hand shut-off valves
- Heat exchangers
- Hose & fittings
- Pressure regulating valves
- Refrigerant distributors
- Safety relief valves
- Solenoid valves
- Thermostatic expansion valves



AEROSPACE

- Flight control systems & components
- Fluid conveyance systems
- Fluid metering delivery & atomization devices
- Fuel systems & components
- Hydraulic systems & components
- Inert nitrogen generating systems
- Pneumatic systems & components
- Wheels & brakes



ELECTROMECHANICAL

- AC/DC drives & systems
- Electric actuators, gantry robots & slides
- Electrohydrostatic actuation systems
- Electromechanical actuation systems
- Human machine interfaces
- Linear motors
- Stepper motors, servo motors, drives & controls
- Structural extrusions



FILTRATION

- Analytical gas generators
- Compressed air & gas filters
- Condition monitoring
- Engine air, fuel & oil filtration & systems
- Hydraulic, lubrication & coolant filters
- Process, chemical, water & microfiltration filters
- Nitrogen, hydrogen & zero air generators



FLUID & GAS HANDLING

- Brass fittings & valves
- Diagnostic equipment
- Fluid conveyance systems
- Industrial hose
- PTFE & PFA hose, tubing & plastic fittings
- Quick disconnects
- Rubber & thermoplastic hose & couplings
- Tube fittings & adapters



HYDRAULICS

- Diagnostic equipment
- Hydraulic cylinders & accumulators
- Hydraulic motors & pumps
- Hydraulic systems
- Hydraulic valves & controls
- Power take-offs
- Quick disconnects
- Rubber & thermoplastic hose & couplings
- Tube fittings & adapters



PNEUMATICS

- Air preparation
- Brass fittings & valves
- Manifolds
- Pneumatic actuators, grippers, valves, controls & accessories
- Quick disconnects
- Rotary actuators
- Rubber & thermoplastic hose & couplings
- Structural extrusions
- Thermoplastic tubing & fittings
- Vacuum generators, cups & sensors



PROCESS CONTROL

- Analytical sample conditioning products & systems
- Fluoropolymer chemical delivery fittings, valves & pumps
- High purity gas delivery fittings, valves & regulators
- Instrumentation fittings, valves & regulators
- Medium pressure fittings & valves
- Process control manifolds



SEALING & SHIELDING

- Dynamic seals
- Elastomeric o-rings
- EMI shielding
- Extruded & precision-cut, fabricated elastomeric seals
- Homogeneous & inserted elastomeric shapes
- High temperature metal seals
- Metal & plastic retained composite seals
- Thermal management

Parker Hannifin Corporation
 Climate and Industrial Controls Group
 2445 South 25th Avenue • Broadview, IL 60155-3891 USA
 phone 800 742 2681 • fax 800 241 2872
www.parker.com/coolparts

102007 / Catalog A-1

