



# HVAC Refrigeration

## TUBE & PIPE

- Copper Tube
- Plastic Coated Copper Tube
- Line Sets
- Black Steel Pipe
- Galvanized Steel Pipe
- ABS DWV Pipe

## METAL FITTINGS & NIPPLES

- Copper Fittings
- Black & Galvanized Iron Fittings
- Black & Galvanized Steel Nipples
- Brass Fittings & Nipples
- Brass Flare Fittings & Flanges

## PLASTIC FITTINGS & NIPPLES

- PVC Sch. 40 Pressure Fittings
- Insert Fittings
- ABS DWV Fittings
- PVC DWV Fittings

## VALVES

- Refrigeration Valves
- Plumbing WOG Valves

## FILTER-DRIERS & STRAINERS

- Filter Driers
- Strainers



# TABLE OF CONTENTS



## TUBE & PIPE

|                            |     |
|----------------------------|-----|
| Copper Tube                | 2-3 |
| Plastic Coated Copper Tube | 3   |
| Line Sets                  | 5   |
| Black Steel Pipe           | 6   |
| Galvanized Steel Pipe      | 6   |
| ABS DWV Pipe               | 7   |

## METAL FITTINGS & NIPPLES

|                                  |       |
|----------------------------------|-------|
| Copper Fittings                  | 8-29  |
| Black & Galvanized Iron Fittings | 30-40 |
| Black & Galvanized Steel Nipples | 41-56 |
| Red Brass Fittings & Nipples     | 57-64 |
| Yellow Brass Fittings & Nipples  | 65-67 |
| Brass Flare Fittings & Flanges   | 68-77 |

## PLASTIC FITTINGS & NIPPLES

|                               |         |
|-------------------------------|---------|
| PVC Sch. 40 Pressure Fittings | 78-87   |
| Insert Fittings               | 88-90   |
| ABS DWV Fittings              | 91-122  |
| PVC DWV Fittings              | 123-151 |

## VALVES

|                       |         |
|-----------------------|---------|
| Refrigeration Valves  | 153-166 |
| Plumbing Valves (WOG) | 167-179 |

## FILTER-DRIERS & STRAINERS

|               |         |
|---------------|---------|
| Filter Driers | 179-181 |
| Strainers     | 182-183 |

# Copper Tube



For decades, Mueller has been producing the best and most trusted copper tube in the industry. The only U.S. manufacturer of both copper tube and copper fittings, Mueller offers a full line of copper tube and coated copper tube products for plumbing, air conditioning, refrigeration, and various other applications. Mueller's ongoing commitment to quality continues to make it the preferred and specified brand of industry professionals.



- Meets applicable ASTM standards B-88, B-306, B-280, B-819
- NSF Approved
- Made in the USA

## COPPER TUBE • PLUMBING

| NOM    | O.D.   | Type K       |             |              | Type L       |             |              | Type M       | DWV          | MEDICAL GAS         |                     |
|--------|--------|--------------|-------------|--------------|--------------|-------------|--------------|--------------|--------------|---------------------|---------------------|
|        |        | Hard Lengths | Soft Coils  | Soft Lengths | Hard Lengths | Soft Coils  | Soft Lengths | Hard Lengths | Hard Lengths | Type K Hard Lengths | Type L Hard Lengths |
| 1/4"   | 3/8"   | 10ft, 20ft   | 60ft, 100ft | 10ft, 20ft   | 10ft, 20ft   | 60ft, 100ft | 10ft, 20ft   |              |              | 10ft, 20ft          | 10ft, 20ft          |
| 3/8"   | 1/2"   | 10ft, 20ft   | 60ft, 100ft | 10ft, 20ft   | 10ft, 20ft   | 60ft, 100ft | 10ft, 20ft   | 10ft, 20ft   |              | 10ft, 20ft          | 10ft, 20ft          |
| 1/2"   | 5/8"   | 10ft, 20ft   | 60ft, 100ft | 10ft, 20ft   | 10ft, 20ft   | 60ft, 100ft | 10ft, 20ft   | 10ft, 20ft   |              | 10ft, 20ft          | 10ft, 20ft          |
| 5/8"   | 3/4"   | 10ft, 20ft   | 60ft, 100ft | 10ft, 20ft   | 10ft, 20ft   | 60ft, 100ft | 10ft, 20ft   | 10ft, 20ft   |              | 10ft, 20ft          | 10ft, 20ft          |
| 3/4"   | 7/8"   | 10ft, 20ft   | 60ft, 100ft | 10ft, 20ft   | 10ft, 20ft   | 60ft, 100ft | 10ft, 20ft   | 10ft, 20ft   |              | 10ft, 20ft          | 10ft, 20ft          |
| 1"     | 1-1/8" | 10ft, 20ft   | 60ft, 100ft | 10ft, 20ft   | 10ft, 20ft   | 60ft, 100ft | 10ft, 20ft   | 10ft, 20ft   |              | 10ft, 20ft          | 10ft, 20ft          |
| 1-1/4" | 1-3/8" | 10ft, 20ft   | 60ft, 100ft | 10ft, 20ft   | 10ft, 20ft   | 60ft, 100ft | 10ft, 20ft   | 10ft, 20ft   | 10ft, 20ft   | 10ft, 20ft          | 10ft, 20ft          |
| 1-1/2" | 1-5/8" | 10ft, 20ft   | 60ft, 100ft | 10ft, 20ft   | 10ft, 20ft   | 60ft, 100ft | 10ft, 20ft   | 10ft, 20ft   | 10ft, 20ft   | 10ft, 20ft          | 10ft, 20ft          |
| 2"     | 2-1/8" | 10ft, 20ft   | 40ft, 60ft  | 10ft, 20ft   | 10ft, 20ft   | 40ft, 60ft  | 10ft, 20ft   | 10ft, 20ft   | 10ft, 20ft   | 10ft, 20ft          | 10ft, 20ft          |
| 2-1/2" | 2-5/8" | 10ft, 20ft   |             | 10ft, 20ft   | 10ft, 20ft   |             | 10ft, 20ft   | 10ft, 20ft   |              | 10ft, 20ft          | 10ft, 20ft          |
| 3"     | 3-1/8" | 10ft, 20ft   |             | 10ft, 20ft   | 10ft, 20ft   |             | 10ft, 20ft   | 10ft, 20ft   | 10ft, 20ft   | 10ft, 20ft          | 10ft, 20ft          |
| 3-1/2" | 3-5/8" | 10ft, 20ft   |             |              | 10ft, 20ft   |             |              | 10ft, 20ft   |              | 10ft, 20ft          | 10ft, 20ft          |
| 4"     | 4-1/8" | 10ft, 20ft   |             |              | 10ft, 20ft   |             |              | 10ft, 20ft   | 10ft, 20ft   | 10ft, 20ft          | 10ft, 20ft          |
| 5"     | 5-1/8" | 10ft, 20ft   |             |              | 10ft, 20ft   |             |              | 10ft, 20ft   | 10ft, 20ft   | 10ft, 20ft          | 10ft, 20ft          |
| 6"     | 6-1/8" | 10ft, 20ft   |             |              | 10ft, 20ft   |             |              | 10ft, 20ft   |              | 10ft, 20ft          | 10ft, 20ft          |
| 8"     | 8-1/8" | 10ft, 20ft   |             |              | 10ft, 20ft   |             |              | 10ft, 20ft   |              | 10ft, 20ft          | 10ft, 20ft          |

(Nitrogenized thru 3-1/8" Only)

## COPPER TUBE • REFRIGERATION

| NITROGENIZED® ACR |              |
|-------------------|--------------|
| O.D.              | Hard Lengths |
| 3/8"              | 10ft, 20ft   |
| 1/2"              | 10ft, 20ft   |
| 5/8"              | 10ft, 20ft   |
| 3/4"              | 10ft, 20ft   |
| 7/8"              | 10ft, 20ft   |
| 1-1/8"            | 10ft, 20ft   |
| 1-3/8"            | 10ft, 20ft   |
| 1-5/8"            | 10ft, 20ft   |
| 2-1/8"            | 10ft, 20ft   |
| 2-5/8"            | 10ft, 20ft   |
| 3-1/8"            | 10ft, 20ft   |
| 3-5/8"            | 10ft, 20ft   |
| 4-1/8"            | 10ft, 20ft   |
| 5-1/8"            | 10ft, 20ft   |
| 6-1/8"            | 10ft, 20ft   |
| 8-1/8"            | 10ft, 20ft   |

| REFRIGERATION SERVICE COILS |              |
|-----------------------------|--------------|
| O.D.                        | Soft Lengths |
| 1/8"                        | 50ft, 100ft  |
| 3/16"                       | 50ft, 100ft  |
| 1/4"                        | 50ft, 100ft  |
| 5/16"                       | 50ft, 100ft  |
| 3/8"                        | 50ft, 100ft  |
| 1/2"                        | 50ft, 100ft  |
| 5/8"                        | 50ft, 100ft  |
| 3/4"                        | 50ft, 100ft  |
| 7/8"                        | 50ft, 100ft  |
| 1-1/8"                      | 50ft, 100ft  |
| 1-3/8"                      | 50ft, 100ft  |
| 1-5/8"                      | 50ft, 100ft  |

| O.D. | Wall Thickness .025 |              | Wall Thickness .032 |              |
|------|---------------------|--------------|---------------------|--------------|
|      | Hard Lengths        | Soft Lengths | Hard Lengths        | Soft Lengths |
|      | 1/4"                | 10ft, 20ft   | 10ft, 20ft          | 10ft, 20ft   |

Temperature Control Tube is not recommended for forming or bending purposes.

Temperature Control Tube order quantities are in 2000 ft. per box increments.

## COPPER TUBE • PLASTIC COATED

Polyethylene coated copper tube: PlumbShield, GasShield, OilShield, Coated ACR

| NOM    | OD     | Type K       |              |               | Type L/ACR   |              |               | Refrigeration Service Coils* |
|--------|--------|--------------|--------------|---------------|--------------|--------------|---------------|------------------------------|
|        |        | Hard Lengths | Soft Lengths | Soft Coils    | Hard Lengths | Soft Lengths | Soft Coils    | Soft Coils                   |
| 1/4"   | 3/8"   | 10ft., 20ft. | 10ft., 20ft. | 60ft., 100ft. | 10ft., 20ft. | 10ft., 20ft. | 60ft., 100ft. | 50ft., 100ft.                |
| 3/8"   | 1/2"   | 10ft., 20ft. | 10ft., 20ft. | 60ft., 100ft. | 10ft., 20ft. | 10ft., 20ft. | 60ft., 100ft. | 50ft., 100ft.                |
| 1/2"   | 5/8"   | 10ft., 20ft. | 10ft., 20ft. | 60ft., 100ft. | 10ft., 20ft. | 10ft., 20ft. | 60ft., 100ft. | 50ft., 100ft.                |
| 5/8"   | 3/4"   | 10ft., 20ft. | 10ft., 20ft. | 60ft., 100ft. | 10ft., 20ft. | 10ft., 20ft. | 60ft., 100ft. | 50ft., 100ft.                |
| 3/4"   | 7/8"   | 10ft., 20ft. | 10ft., 20ft. | 60ft., 100ft. | 10ft., 20ft. | 10ft., 20ft. | 60ft., 100ft. | 50ft., 100ft.                |
| 1"     | 1-1/8" | 10ft., 20ft. | 10ft., 20ft. | 60ft., 100ft. | 10ft., 20ft. | 10ft., 20ft. | 60ft., 100ft. | 50ft., 100ft.                |
| 1-1/4" | 1-3/8" | 10ft., 20ft. | 10ft., 20ft. | 60ft., 100ft. | 10ft., 20ft. | 10ft., 20ft. | 60ft., 100ft. |                              |
| 1-1/2" | 1-5/8" | 10ft., 20ft. | 10ft., 20ft. | 60ft., 100ft. | 10ft., 20ft. | 10ft., 20ft. | 60ft., 100ft. |                              |
| 2"     | 2-1/8" | 10ft., 20ft. | 10ft., 20ft. | 40ft., 60ft.  | 10ft., 20ft. | 10ft., 20ft. | 40ft., 60ft.  |                              |

**PlumbShield™** available in blue and red for water applications and purple for reclaimed water

**GasShield™** available in yellow for natural and LP Gas applications

**OilShield™** available in orange for fuel and oil applications

**Coated ACR** available in White for HVAC applications

\* Available in OD sizes only



# Line Sets



Mueller Line Sets are the industry standard for quality. We leverage our many years of copper tube expertise in every line set we make. From liquid line and suction line handling to unique insulation applications and packaging, every Mueller Line Set meets our tough standards so our customers receive the best line set in the industry. Mueller offers a full line of liquid line and suction line diameters, insulation thicknesses, lengths, custom ends, connections, and other services.

- Copper tubing meets ASTM B-280
- Insulation meets ASTM C-534
- UL 25-50 rated
- Made in the USA



## CUSTOM OPTIONS

Mueller offers a full variety of custom lengths, options and connection assemblies to meet customer line set needs.

- Insulated Liquid and Suction Lines for Mini-Split Systems
- Thermostat Wire and Taping
- Custom Ends/Bends
- Flare Nuts, Custom Connections & Assemblies
- Nitrogen & Refrigerant Charged Lines

## LINE SET PART # SCHEMATIC

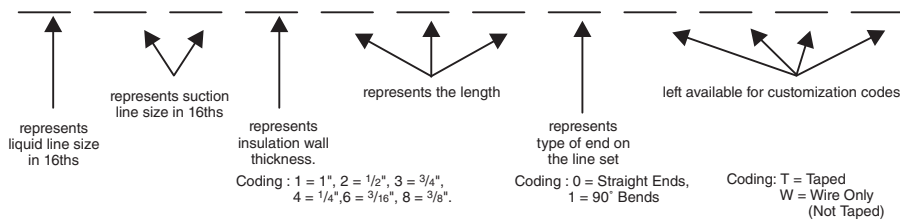

### EXAMPLE:

Part # 61280500T186

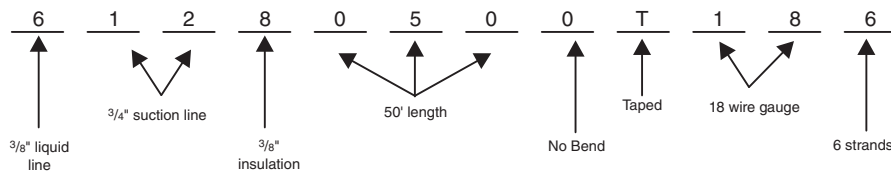

## LINE SETS

| Series No. | LL x SL x INS     | QUANTITY PER MASTER CARTON |     |     |     |     |     |     |     |     |     |                      |     |     |     |     |     |     |     |     |     |
|------------|-------------------|----------------------------|-----|-----|-----|-----|-----|-----|-----|-----|-----|----------------------|-----|-----|-----|-----|-----|-----|-----|-----|-----|
|            |                   | Standard Line Sets         |     |     |     |     |     |     |     |     |     | Mini Split Line Sets |     |     |     |     |     |     |     |     |     |
|            |                   | 10'                        | 15' | 20' | 25' | 30' | 35' | 40' | 45' | 50' | 60' | 10'                  | 15' | 20' | 25' | 30' | 35' | 40' | 45' | 50' | 60' |
| <b>406</b> | 1/4 x 3/8 x 1/4   | 14                         | 14  | 14  | 14  | 14  | 12  | 12  | 8   | 8   | 7   | 14                   | 14  | 14  | 14  | 14  | 12  | 12  | 8   | 8   | 7   |
|            | 3/8               | 14                         | 14  | 14  | 14  | 14  | 12  | 12  | 8   | 8   | 7   | —                    | —   | —   | —   | —   | —   | —   | —   | —   | —   |
| <b>408</b> | 1/4 x 1/2 x 1/4   | 14                         | 14  | 14  | 14  | 14  | 12  | 12  | 8   | 7   | 7   | —                    | —   | —   | —   | —   | —   | —   | —   | —   | —   |
|            | 3/8               | 14                         | 14  | 14  | 14  | 14  | 12  | 12  | 8   | 7   | 7   | 14                   | 14  | 14  | 14  | 14  | 12  | 12  | 8   | 7   | 7   |
|            | 1/2               | 14                         | 14  | 14  | 14  | 12  | 8   | 8   | 8   | 7   | 5   | 14                   | 14  | 14  | 14  | 12  | 8   | 8   | 8   | 7   | 5   |
|            | 3/4               | 14                         | 14  | 8   | 8   | 7   | 7   | 5   | 4   | 4   | 4   | 14                   | 14  | 8   | 8   | 7   | 7   | 5   | 4   | 4   | 4   |
| <b>410</b> | 1/4 x 5/8 x 1/4   | 14                         | 14  | 14  | 14  | 12  | 8   | 8   | 8   | 8   | 7   | 14                   | 14  | 14  | 14  | 12  | 8   | 8   | 8   | 8   | 7   |
|            | 3/8               | 14                         | 14  | 14  | 14  | 12  | 8   | 8   | 8   | 8   | 7   | —                    | —   | —   | —   | —   | —   | —   | —   | —   | —   |
|            | 1/2               | 14                         | 14  | 12  | 12  | 8   | 8   | 8   | 7   | 7   | 5   | 14                   | 14  | 12  | 12  | 8   | 8   | 8   | 7   | 7   | 5   |
|            | 3/4               | 12                         | 12  | 12  | 8   | 7   | 7   | 7   | 7   | 5   | 5   | 12                   | 12  | 12  | 8   | 7   | 7   | 7   | 7   | 5   | 5   |
| <b>510</b> | 5/16 x 5/8 x 1/4  | 14                         | 14  | 14  | 14  | 12  | 8   | 8   | 8   | 8   | 7   | —                    | —   | —   | —   | —   | —   | —   | —   | —   | —   |
|            | 3/8               | 14                         | 14  | 14  | 14  | 12  | 8   | 8   | 8   | 8   | 7   | 14                   | 14  | 14  | 14  | 12  | 8   | 8   | 8   | 8   | 7   |
|            | 1/2               | 14                         | 14  | 12  | 12  | 8   | 8   | 8   | 7   | 7   | 5   | 14                   | 14  | 12  | 12  | 8   | 8   | 8   | 7   | 7   | 5   |
|            | 3/4               | 12                         | 12  | 12  | 8   | 8   | 8   | 8   | 7   | 5   | 5   | 12                   | 12  | 12  | 8   | 8   | 8   | 8   | 7   | 5   | 5   |
| <b>610</b> | 3/8 x 5/8 x 1/4   | 14                         | 14  | 14  | 14  | 12  | 8   | 8   | 8   | 8   | 7   | —                    | —   | —   | —   | —   | —   | —   | —   | —   | —   |
|            | 3/8               | 14                         | 14  | 14  | 14  | 12  | 8   | 8   | 8   | 8   | 7   | 14                   | 14  | 14  | 14  | 12  | 8   | 8   | 8   | 8   | 7   |
|            | 1/2               | 14                         | 14  | 12  | 12  | 8   | 8   | 8   | 7   | 7   | 5   | 14                   | 14  | 12  | 12  | 8   | 8   | 8   | 7   | 7   | 5   |
|            | 3/4               | 12                         | 12  | 12  | 7   | 7   | 5   | 5   | 5   | 5   | 5   | 12                   | 12  | 12  | 7   | 7   | 5   | 5   | 5   | 5   | 5   |
| <b>412</b> | 1/4 x 3/4 x 1/4   | 14                         | 14  | 14  | 12  | 12  | 8   | 8   | 7   | 7   | 5   | —                    | —   | —   | —   | —   | —   | —   | —   | —   | —   |
|            | 3/8               | 14                         | 14  | 14  | 12  | 12  | 8   | 8   | 7   | 7   | 5   | 14                   | 14  | 14  | 12  | 12  | 8   | 8   | 7   | 7   | 5   |
|            | 1/2               | 14                         | 14  | 12  | 8   | 8   | 7   | 7   | 5   | 5   | 4   | 14                   | 14  | 12  | 8   | 8   | 7   | 7   | 5   | 5   | 4   |
|            | 3/4               | 12                         | 8   | 8   | 8   | 5   | 5   | 5   | 4   | 4   | 4   | 12                   | 8   | 8   | 8   | 5   | 5   | 5   | 4   | 4   | 4   |
| <b>512</b> | 5/16 x 3/4 x 1/4  | 14                         | 14  | 14  | 12  | 12  | 8   | 8   | 7   | 7   | 5   | —                    | —   | —   | —   | —   | —   | —   | —   | —   | —   |
|            | 3/8               | 14                         | 14  | 14  | 12  | 12  | 8   | 8   | 7   | 7   | 5   | 14                   | 14  | 14  | 12  | 12  | 8   | 8   | 7   | 7   | 5   |
|            | 1/2               | 14                         | 14  | 12  | 8   | 8   | 7   | 7   | 5   | 5   | 4   | 14                   | 14  | 12  | 8   | 8   | 7   | 7   | 5   | 5   | 4   |
|            | 3/4               | 12                         | 8   | 8   | 8   | 5   | 5   | 5   | 4   | 4   | 4   | 12                   | 8   | 8   | 8   | 5   | 5   | 5   | 4   | 4   | 4   |
| <b>612</b> | 3/8 x 3/4 x 1/4   | 14                         | 14  | 14  | 12  | 12  | 8   | 8   | 7   | 7   | 5   | —                    | —   | —   | —   | —   | —   | —   | —   | —   | —   |
|            | 3/8               | 14                         | 14  | 14  | 12  | 12  | 8   | 8   | 7   | 7   | 5   | 14                   | 14  | 14  | 12  | 12  | 8   | 8   | 7   | 7   | 5   |
|            | 1/2               | 14                         | 14  | 12  | 8   | 8   | 7   | 7   | 5   | 5   | 4   | 14                   | 14  | 12  | 8   | 8   | 7   | 7   | 5   | 5   | 4   |
|            | 3/4               | 12                         | 8   | 8   | 8   | 5   | 5   | 5   | 4   | 4   | 4   | 12                   | 8   | 8   | 8   | 5   | 5   | 5   | 4   | 4   | 4   |
|            | 1                 | —                          | —   | —   | —   | —   | —   | —   | —   | —   | —   | 12                   | 8   | 8   | 8   | 5   | 5   | 5   | 4   | 4   | 4   |
| <b>614</b> | 3/8 x 7/8 x 1/4   | 14                         | 14  | 12  | 12  | 8   | 8   | 8   | 7   | 7   | 5   | —                    | —   | —   | —   | —   | —   | —   | —   | —   | —   |
|            | 3/8               | 14                         | 14  | 12  | 12  | 8   | 8   | 8   | 7   | 7   | 5   | 14                   | 14  | 12  | 12  | 8   | 8   | 8   | 7   | 7   | 5   |
|            | 1/2               | 14                         | 12  | 8   | 8   | 7   | 7   | 5   | 5   | 5   | 4   | 14                   | 12  | 8   | 8   | 7   | 7   | 5   | 5   | 5   | 4   |
|            | 3/4               | 12                         | 8   | 8   | 7   | 5   | 5   | 4   | 4   | 4   | 4   | 12                   | 8   | 8   | 7   | 5   | 5   | 4   | 4   | 4   | 4   |
|            | 1                 | —                          | —   | —   | —   | —   | —   | —   | —   | —   | —   | 12                   | 8   | 8   | 7   | 5   | 5   | 4   | 4   | 4   | 4   |
| <b>618</b> | 3/8 x 1-1/8 x 1/4 | 8                          | 8   | 8   | 8   | 7   | 7   | 5   | 5   | 5   | N/A | —                    | —   | —   | —   | —   | —   | —   | —   | —   | —   |
|            | 3/8               | 8                          | 8   | 8   | 8   | 7   | 7   | 5   | 5   | 5   | N/A | 8                    | 8   | 8   | 8   | 7   | 7   | 5   | 5   | 5   | 5   |
|            | 1/2               | 8                          | 8   | 8   | 8   | 7   | 5   | 5   | 4   | 4   | N/A | 8                    | 8   | 8   | 8   | 7   | 5   | 5   | 4   | 4   | 4   |
|            | 3/4               | 8                          | 7   | 7   | 7   | 5   | 4   | 4   | 4   | 4   | N/A | 8                    | 7   | 7   | 7   | 5   | 4   | 4   | 4   | 4   | 4   |
|            | 1                 | —                          | —   | —   | —   | —   | —   | —   | —   | —   | —   | 8                    | 7   | 7   | 7   | 5   | 4   | 4   | 4   | 4   | 4   |

Mini Split Line Sets  
 LL- Liquid Line  
 SL- Suction Line  
 INS- Insulation

**TUBE & PIPE**  
 METAL FITTINGS & NIPPLES  
 PLASTIC FITTINGS  
 VALVES  
 FILTER-DRYERS & STRAINERS



# Steel Pipe



Mueller provides an impressive line of black steel and galvanized steel pipe products that are manufactured to rigid industry standards and backed by Mueller's trusted name and assurance of quality. Our standard welded steel pipe is available in 1/4" - 4" diameters and offered in either 10 foot or 21 foot cut lengths. Mueller Steel Pipe is available in either plain, threaded, or threaded and coupled ends.



- Threads comply with ANSI B1.20.1
- Pipe complies with ANSI/ASTM A.733, A53
- NAFTA approved

## 10 FT THREADED STEEL PIPE

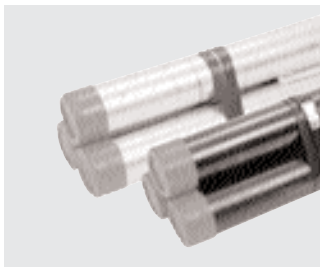

| GALVANIZED | BLACK | Size         | Weight Approx. (Lbs.) | Pieces Per Bundle | Master Wt. (Lbs.) |
|------------|-------|--------------|-----------------------|-------------------|-------------------|
| 10424      | 20424 | 1/2" x 10'   | 8.5319                | 5                 | 43                |
| 10524      | 20524 | 3/4" x 10'   | 11.3538               | 5                 | 57                |
| 10624      | 20624 | 1" x 10'     | 16.7970               | 3                 | 50                |
| 10724      | 20724 | 1-1/4" x 10' | 22.7760               | 3                 | 68                |
| 10824      | 20824 | 1-1/2" x 10' | 27.2117               | 3                 | 82                |
| 10924      | 20924 | 2" x 10'     | 36.5504               | 2                 | 73                |
| 11024      | 21024 | 2-1/2" x 10' | 57.9838               | 18                | -                 |
| 11124      | 21124 | 3" x 10'     | 75.8567               | 14                | -                 |
| 11224      | 21224 | 4" x 10'     | 107.9714              | 10                | -                 |

## 21 FT PLAIN END & BEVELED STEEL PIPE

| GALVANIZED | BLACK   | Size         | Weight Approx. (Lbs.) | Pieces Per Bundle | Master Wt. (Lbs.) |
|------------|---------|--------------|-----------------------|-------------------|-------------------|
| 10430LB    | 20430LB | 1/2" x 21'   | 17.9192               | 5                 | 90                |
| 10530LB    | 20530LB | 3/4" x 21'   | 23.8452               | 5                 | 119               |
| 10630LB    | 20630LB | 1" x 21'     | 35.2740               | 3                 | 106               |
| 10730LB    | 20730LB | 1-1/4" x 21' | 47.8315               | 3                 | 143               |
| 10830LB    | 20830LB | 1-1/2" x 21' | 57.1438               | 3                 | 171               |
| 10930LB    | 20930LB | 2" x 21'     | 76.7562               | 2                 | 154               |
| 11030LB    | 21030LB | 2-1/2" x 21' | 121.7657              | 18                | -                 |
| 11130LB    | 21130LB | 3" x 21'     | 159.2972              | 14                | -                 |
| 11230LB    | 21230LB | 4" x 21'     | 226.7411              | 10                | -                 |

## 21 FT THREADED & COUPLED STEEL PIPE

| GALVANIZED | BLACK  | Size         | Weight Approx. (Lbs.) | Pieces Per Bundle | Master Wt. (Lbs.) |
|------------|--------|--------------|-----------------------|-------------------|-------------------|
| 10430C     | 20430C | 1/2" x 21'   | 17.9192               | 5                 | 90                |
| 10530C     | 20530C | 3/4" x 21'   | 23.8452               | 5                 | 119               |
| 10630C     | 20630C | 1" x 21'     | 35.2740               | 3                 | 106               |
| 10730C     | 20730C | 1-1/4" x 21' | 47.8315               | 3                 | 143               |
| 10830C     | 20830C | 1-1/2" x 21' | 57.1438               | 3                 | 171               |
| 10930C     | 20930C | 2" x 21'     | 76.7562               | 2                 | 154               |
| 11030C     | 21030C | 2-1/2" x 21' | 121.7657              | 18                | -                 |
| 11130C     | 21130C | 3" x 21'     | 159.2972              | 14                | -                 |
| 11230C     | 21230C | 4" x 21'     | 226.7411              | 10                | -                 |

# ABS DWV Pipe



Mueller's modern manufacturing technology provides a consistent and dense cellular structure while also ensuring a uniform pipe wall. Our unique and precise processes create ABS DWV Pipe at the highest quality levels. This means uncompromising and reliable performance for our customers.

- Smooth and consistent interior wall provides for full flow, resistance to corrosion or scaling
- Smooth and consistent exterior wall provides for easy and reliable joining, joint performance, and attractive appearance
- Dense and uniform cellular (foam) structure provides, reliable, strong, and quiet product
- Uniform interior and exterior wall skin for a strong and reliable joint
- 25 year warranty

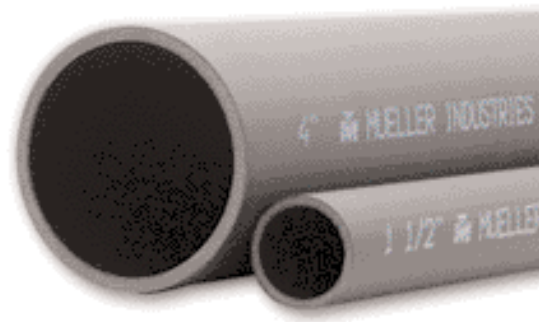

- TUBE & PIPE
- METAL FITTINGS & NIPPLES
- PLASTIC FITTINGS
- VALVES
- FILTER-DRIERS & STRAINERS

## ABS DWV PIPE

### ABS DWV PIPE – 10 FT

| ABS DWV Schedule 40 Cellular Core, Plain End, Black, ASTM F-628 |        |             |               |                 |                           |                      |
|---|--------|-------------|---------------|-----------------|---------------------------|----------------------|
| Nom. Size   | Length | Part Number | Feet Per Lift | Pieces Per Lift | Weight (lbs.) Per 100 ft. | Truckload % Per Lift |
| 1-1/2"  | 10 ft. | APC015010   | 2590          | 259             | 27.3                      | 2.5                  |
| 2"  | 10 ft. | APC020010   | 1670          | 167             | 37.8                      | 2.5                  |
| 3"  | 10 ft. | APC030010   | 750           | 75              | 74.5                      | 2.5                  |
| 4"  | 10 ft. | APC040010   | 480           | 48              | 103.9                     | 2.5                  |
| 6"  | 10 ft. | APC060010   | 180           | 18              | 186.9                     | 2.5                  |

### ABS DWV PIPE – 20 FT

| ABS DWV Schedule 40 Cellular Core, Plain End, Black, ASTM F-628 |        |             |               |                 |                           |                      |
|---|--------|-------------|---------------|-----------------|---------------------------|----------------------|
| Nom. Size   | Length | Part Number | Feet Per Lift | Pieces Per Lift | Weight (lbs.) Per 100 ft. | Truckload % Per Lift |
| 1-1/2"  | 20 ft. | APC015020   | 5,180         | 259             | 27.3                      | 5                    |
| 2"  | 20 ft. | APC020020   | 3,340         | 167             | 37.8                      | 5                    |
| 3"  | 20 ft. | APC030020   | 1,500         | 75              | 74.5                      | 5                    |
| 4"  | 20 ft. | APC040020   | 960           | 48              | 103.9                     | 5                    |
| 6"  | 20 ft. | APC060020   | 360           | 18              | 186.9                     | 5                    |



# WROT & CAST Copper Fittings



In 1930, Mueller invented and pioneered the now famous Streamline solder type copper fitting. This development led to making all copper plumbing the standard of the industry. Today, Mueller offers one of the industry's most complete lines of copper products from one source. Included are wrot and cast pressure and DWV fittings. Mueller's many years of engineering know how and experience is reflected in the fine quality and workmanship of each copper fitting.

- Meet applicable ANSI/ASME standards B16.22, B16.29, B16.18, B16.15, B16.26, B16.24, B16.23
- NSF Approved
- Made in the USA



## ADAPTER • FEMALE

## COPPER FITTING

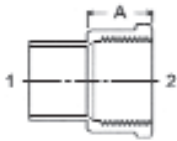

### CONNECTION C x F

| I               | Size            |   | Part Number | Box Qty. | Master Qty. | Approx. Net.Wt. | Dimensions |   |   |
|-----------------|-----------------|---|-------------|----------|-------------|-----------------|------------|---|---|
|                 | 2               | 3 |             |          |             |                 | A          | B | C |
| <b>REDUCING</b> |                 |   |             |          |             |                 |            |   |   |
|                 | 1/4" x 1/2"     |   | W 01204     | 100      | 300         | .1              | 15/64      |   |   |
|                 | 1/4" x 3/8"     |   | W 01205     | 100      | 700         | .05             | 5/8        |   |   |
|                 | 1/4" x 1/4"     |   | W 01206     | 100      | 900         | .04             | 21/32      |   |   |
|                 | 1/4" x 1/8"     |   | W 01207     | 100      | 1,500       | .04             | 9/16       |   |   |
|                 | 3/8" x 3/8"     |   | W 01214     | 50       | 1,000       | .06             | 21/32      |   |   |
|                 | 3/8" x 1/4"     |   | W 01215     | 50       | 750         | .04             | 5/8        |   |   |
|                 | 3/8" x 1/8"     |   | W 01216     | 100      | 1,500       | .03             | 17/32      |   |   |
|                 | 1/2" x 3/4"     |   | W 01223     | 50       | 300         | .16             | 13/16      |   |   |
|                 | 1/2" x 1/2"     |   | W 01224     | 50       | 500         | .10             | 1          |   |   |
|                 | 1/2" x 3/8"     |   | W 01225     | 50       | 750         | .07             | 53/64      |   |   |
|                 | 1/2" x 1/4"     |   | W 01226     | 50       | 750         | .06             | 19/32      |   |   |
|                 | 5/8" x 3/4"     |   | W 01230     | 25       | 250         | .15             | 1-3/64     |   |   |
|                 | 5/8" x 1/2"     |   | W 01231     | 50       | 500         | .10             | 27/32      |   |   |
|                 | 5/8" x 3/8"     |   | W 01232     | 50       | 500         | .07             | 49/64      |   |   |
|                 | 5/8" x 1/4"     |   | W 01233     | 50       | 500         | .06             | 1/2        |   |   |
|                 | 3/4" x 3/4"     |   | W 01238     | 50       | 500         | .15             | 57/64      |   |   |
|                 | 3/4" x 1/2"     |   | W 01239     | 50       | 500         | .09             | 29/32      |   |   |
|                 | 7/8" x 1"       |   | W 01245     | 25       | 250         | .27             | 1-5/32     |   |   |
|                 | 7/8" x 3/4"     |   | W 01246     | 25       | 250         | .22             | 13/16      |   |   |
|                 | 7/8" x 1/2"     |   | W 01247     | 25       | 250         | .11             | 1          |   |   |
|                 | 1-1/8" x 1-1/4" |   | W 01261     | 10       | 100         | .28             | 1-7/32     |   |   |
|                 | 1-1/8" x 1"     |   | W 01263     | 25       | 250         | .24             | 31/32      |   |   |



**ADAPTER • FEMALE continued**

**COPPER FITTING**

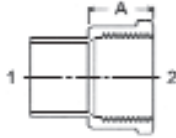

CONNECTION  
**C x F**

| I               | Size            |   | Part Number | Box Qty. | Master Qty. | Approx. Net.Wt. | Dimensions |   |   |
|-----------------|-----------------|---|-------------|----------|-------------|-----------------|------------|---|---|
|                 | 2               | 3 |             |          |             |                 | A          | B | C |
| <b>REDUCING</b> |                 |   |             |          |             |                 |            |   |   |
|                 | 1-1/8" x 3/4"   |   | W 01264     | 25       | 250         | .22             | 13/16      |   |   |
|                 | 1-1/8" x 1/2"   |   | W 01265     | 20       | 200         | .25             | 23/32      |   |   |
|                 | 1-3/8" x 1-1/2" |   | W 01270     | 10       | 100         | .5              | 1-13/32    |   |   |
|                 | 1-3/8" x 1-1/4" |   | W 01271     | 10       | 100         | .45             | 1-7/32     |   |   |
|                 | 1-3/8" x 1"     |   | W 01272     | 10       | 100         | .33             | 1          |   |   |
|                 | 1-5/8" x 2"     |   | W 01278     | -        | 60          | .74             | 1-7/32     |   |   |
|                 | 1-5/8" x 1-1/2" |   | W 01279     | 10       | 100         | .53             | 1-1/4      |   |   |
|                 | 1-5/8" x 1-1/4" |   | W 01280     | 5        | 50          | .39             | 29/32      |   |   |
|                 | 2-1/8" x 2"     |   | W 01287     | -        | 50          | .57             | 15/16      |   |   |
|                 | 2-1/8" x 1-1/2" |   | W 01288     | 5        | 50          | .74             | 1-3/16     |   |   |
|                 | 2-5/8" x 2-1/2" |   | W 01296     | -        | 25          | 1.22            | 1-3/16     |   |   |
|                 | 3-1/8" x 3"     |   | W 01297     | -        | 15          | 1.83            | 1-5/16     |   |   |

**ADAPTER • FITTING**

**COPPER FITTING**

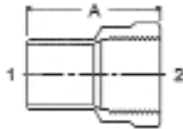

CONNECTION  
**FTG x F**

| I               | Size            |   | Part Number | Box Qty. | Master Qty. | Approx. Net.Wt. | Dimensions |   |   |
|-----------------|-----------------|---|-------------|----------|-------------|-----------------|------------|---|---|
|                 | 2               | 3 |             |          |             |                 | A          | B | C |
| <b>REDUCING</b> |                 |   |             |          |             |                 |            |   |   |
|                 | 3/8" x 3/8"     |   | W 01514     | 50       | 750         | .06             | 1-9/32     |   |   |
|                 | 1/2" x 1/2"     |   | W 01524     | 50       | 350         | .1              | 1-15/32    |   |   |
|                 | 1/2" x 3/8"     |   | W 01525     | 50       | 750         | .05             | 1-19/64    |   |   |
|                 | 1/2" x 1/4"     |   | W 01526     | 50       | 750         | .06             | 1-1/8      |   |   |
|                 | 5/8" x 1/2"     |   | W 01531     | 50       | 450         | .11             | 1-1/2      |   |   |
|                 | 5/8" x 3/8"     |   | W 01532     | 50       | 750         | .07             | 1-19/64    |   |   |
|                 | 7/8" x 3/4"     |   | W 01546     | 25       | 250         | .17             | 1-45/64    |   |   |
|                 | 7/8" x 1/2"     |   | W 01547     | 50       | 500         | .11             | 1-11/16    |   |   |
|                 | 1-1/8" x 1"     |   | W 01563     | 25       | 250         | .24             | 2-5/64     |   |   |
|                 | 1-1/8" x 3/4"   |   | W 01564     | 25       | 250         | .18             | 1-49/64    |   |   |
|                 | 1-3/8" x 1-1/4" |   | W 01571     | 10       | 100         | .4              | 2-7/32     |   |   |
|                 | 1-5/8" x 1-1/2" |   | W 01579     | 10       | 100         | .46             | 2-15/32    |   |   |
|                 | 2-1/8" x 2"     |   | W 01587     | -        | 50          | .65             | 2-13/32    |   |   |
|                 | 2-5/8" x 2-1/2" |   | W 01596     | -        | 25          | 1.2             | 2-53/64    |   |   |

**ADAPTER • MALE**

**COPPER FITTING**

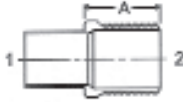

CONNECTION  
**C x M**

MUELLER STYLE  
WC-401

ELKHART STYLE  
104

NIBCO STYLE  
9604

| 1               | Size<br>2       | 3 | Part<br>Number | Box<br>Qty. | Master<br>Qty. | Approx.<br>Net.Wt. | Dimensions |   |   |
|-----------------|-----------------|---|----------------|-------------|----------------|--------------------|------------|---|---|
|                 |                 |   |                |             |                |                    | A          | B | C |
| <b>REDUCING</b> |                 |   |                |             |                |                    |            |   |   |
|                 | 1/4" x 3/8"     |   | W 01105        | 50          | 1000           | .06                | 3/4        |   |   |
|                 | 1/4" x 1/4"     |   | W 01106        | 50          | 1,200          | .03                | 49/64      |   |   |
|                 | 1/4" x 1/8"     |   | W 01107        | 50          | 1,000          | .02                | 27/64      |   |   |
|                 | 5/16" x 1/8"    |   | W 01109*       | 50          | 800            | .07                | 27/32      |   |   |
|                 | 5/16" x 1/4"    |   | W 01110*       | 50          | 1,200          | .03                | 5/8        |   |   |
|                 | 1/4" x 1/2"     |   | W 01113        | 50          | 500            | .08                | 1          |   |   |
|                 | 3/8" x 1/2"     |   | W 01113        | 50          | 500            | .08                | 1          |   |   |
|                 | 3/8" x 3/8"     |   | W 01114        | 50          | 1,000          | .06                | 63/64      |   |   |
|                 | 3/8" x 1/4"     |   | W 01115        | 50          | 1,200          | .03                | 21/32      |   |   |
|                 | 3/8" x 1/8"     |   | W 01116        | 50          | 1,000          | .02                | 17/32      |   |   |
|                 | 1/2" x 3/4"     |   | W 01123        | 25          | 250            | .17                | 1-7/64     |   |   |
|                 | 1/2" x 1/2"     |   | W 01124        | 50          | 500            | .09                | 13/16      |   |   |
|                 | 1/2" x 3/8"     |   | W 01125        | 50          | 500            | .06                | 21/32      |   |   |
|                 | 1/2" x 1/4"     |   | W 01126        | 50          | 750            | .05                | 7/8        |   |   |
|                 | 5/8" x 1"       |   | W 01129        | 15          | 150            | .3                 | 1-29/64    |   |   |
|                 | 5/8" x 3/4"     |   | W 01130        | 25          | 250            | .16                | 15/16      |   |   |
|                 | 5/8" x 1/2"     |   | W 01131        | 50          | 500            | .08                | 13/16      |   |   |
|                 | 5/8" x 3/8"     |   | W 01132        | 50          | 500            | .07                | 41/64      |   |   |
|                 | 5/8" x 1/4"     |   | W 01133        | 25          | 600            | .06                | 3/4        |   |   |
|                 | 3/4" x 3/4"     |   | W 01138        | 25          | 250            | .14                | 1-1/64     |   |   |
|                 | 3/4" x 1/2"     |   | W 01139        | 10          | 100            | .12                | 3/4        |   |   |
|                 | 7/8" x 1"       |   | W 01145        | 10          | 100            | .29                | 1-5/32     |   |   |
|                 | 7/8" x 3/4"     |   | W 01146        | 25          | 250            | .14                | 1-15/32    |   |   |
|                 | 7/8" x 1/2"     |   | W 01147        | 25          | 250            | .12                | 7/8        |   |   |
|                 | 1-1/8" x 1-1/2" |   | W 01161        | 10          | 100            | .48                | 1-45/64    |   |   |
|                 | 1-1/8" x 1-1/4" |   | W 01162        | 10          | 100            | .39                | 1-9/16     |   |   |
|                 | 1-1/8" x 1"     |   | W 01163        | 10          | 100            | .24                | 1-9/64     |   |   |
|                 | 1-1/8" x 3/4"   |   | W 01164        | 10          | 100            | .17                | 59/64      |   |   |
|                 | 1-1/8" x 1/2"   |   | W 01165        | 25          | 250            | .18                | 31/32      |   |   |
|                 | 1-3/8" x 1-1/2" |   | W 01170        | 10          | 100            | .48                | 1-21/32    |   |   |
|                 | 1-3/8" x 1-1/4" |   | W 01171        | 10          | 100            | .41                | 1-9/32     |   |   |
|                 | 1-3/8" x 1"     |   | W 01172        | 10          | 100            | .24                | 2-1/4      |   |   |
|                 | 1-3/8" x 3/4"   |   | W 01173        | 10          | 100            | .21                | 31/32      |   |   |
|                 | 1-5/8" x 2"     |   | W 01178        | -           | 50             | .78                | 1-7/32     |   |   |
|                 | 1-5/8" x 1-1/2" |   | W 01179        | 10          | 100            | .51                | 1-1/4      |   |   |
|                 | 1-5/8" x 1-1/4" |   | W 01180        | 10          | 100            | .37                | 1-1/8      |   |   |
|                 | 1-5/8" x 1"     |   | W 01181        | 10          | 100            | .38                | 1-3/32     |   |   |
|                 | 2-1/8" x 2"     |   | W 01187        | 5           | 50             | .57                | 1-19/64    |   |   |
|                 | 2-1/8" x 1-1/2" |   | W 01188        | -           | 50             | .64                | 1-3/32     |   |   |
|                 | 2-1/8" x 1-1/4" |   | W 01189        | -           | 50             | .57                | 1-5/32     |   |   |
|                 | 2-5/8" x 2-1/2" |   | W 01196        | -           | 20             | 1.26               | 1-21/32    |   |   |
|                 | 2-5/8" x 2"     |   | W 01197        | -           | 20             | .98                | 1-1/8      |   |   |
|                 | 2-5/8" x 1-1/2" |   | W 01198        | -           | 22             | .98                | 1-7/32     |   |   |
|                 | 3-1/8" x 3"     |   | W 01199        | -           | 20             | 1.7                | 1-27/64    |   |   |
|                 | 4-1/8" x 4"     |   | W 01150        | -           | 16             | 3.71               | 1-29/32    |   |   |



**ADAPTER • FITTING**

**COPPER FITTING**

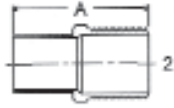
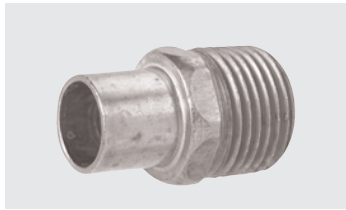

**CONNECTION  
C x C**

MUELLER STYLE  
WC-400NS

ELKHART STYLE  
101

NIBCO STYLE  
9601

| I | Size<br>2       | 3 | Part<br>Number | Box<br>Qty. | Master<br>Qty. | Approx.<br>Net.Wt. | Dimensions |   |   |
|---|-----------------|---|----------------|-------------|----------------|--------------------|------------|---|---|
|   |                 |   |                |             |                |                    | A          | B | C |
|   | 3/8" x 3/8"     |   | W 01414        | 50          | 750            | .06                | 1-1/4      |   |   |
|   | 1/2" x 3/8"     |   | W 01425        | 50          | 1000           | .04                | 1-1/4      |   |   |
|   | 5/8" x 1/2"     |   | W 01431        | 50          | 500            | .09                | 1-3/8      |   |   |
|   | 5/8" x 3/8"     |   | W 01432        | 50          | 1000           | .06                | 1-11/32    |   |   |
|   | 7/8" x 3/4"     |   | W 01446        | 50          | 500            | .15                | 1-59/64    |   |   |
|   | 7/8" x 1/2"     |   | W 01447        | 25          | 250            | .13                | 1-23/32    |   |   |
|   | 1-1/8" x 1"     |   | W 01463        | 25          | 250            | .23                | 2-1/4      |   |   |
|   | 1-1/8" x 3/4"   |   | W 01464        | 25          | 250            | .19                | 2-3/64     |   |   |
|   | 1-3/8" x 1-1/4" |   | W 01471        | 10          | 100            | .41                | 2-15/32    |   |   |
|   | 1-5/8" x 1-1/2" |   | W 01479        | 10          | 100            | .49                | 2-19/32    |   |   |
|   | 2-1/8" x 2"     |   | W 01487        | -           | 50             | .76                | 2-49/64    |   |   |
|   | 2-5/8" x 2-1/2" |   | W 01496        | -           | 25             | 1.95               | 3-3/8      |   |   |

**BUSHING • FLUSH**

**COPPER FITTING**

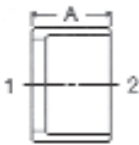

**CONNECTION  
FTG x C**

MUELLER STYLE  
WC-106

ELKHART STYLE  
119

NIBCO STYLE  
9618

| I | Size<br>2       | 3 | Part<br>Number | Box<br>Qty. | Master<br>Qty. | Approx.<br>Net.Wt. | Dimensions |   |   |
|---|-----------------|---|----------------|-------------|----------------|--------------------|------------|---|---|
|   |                 |   |                |             |                |                    | A          | B | C |
|   | 3/8" x 1/4"     |   | W 01706        | 100         | 3,400          | .01                | 3/8        |   |   |
|   | 1/2" x 3/8"     |   | W 01712        | 100         | 3,400          | .01                | 7/16       |   |   |
|   | 1/2" x 1/4"     |   | W 01714        | 100         | 2,400          | .02                | 7/16       |   |   |
|   | 5/8" x 1/2"     |   | W 01715        | 100         | 1,500          | .02                | 9/16       |   |   |
|   | 5/8" x 3/8"     |   | W 01717        | 100         | 1,500          | .04                | 9/16       |   |   |
|   | 3/4" x 5/8"     |   | W 01720        | 50          | 750            | .03                | 11/16      |   |   |
|   | 3/4" x 1/2"     |   | W 01721        | 50          | 750            | .06                | 11/16      |   |   |
|   | 3/4" x 3/8"     |   | W 01722        | 50          | 750            | .08                | 11/16      |   |   |
|   | 7/8" x 3/4"     |   | W 01725        | 50          | 500            | .04                | 13/16      |   |   |
|   | 7/8" x 5/8"     |   | W 01726        | 50          | 500            | .07                | 13/16      |   |   |
|   | 7/8" x 1/2"     |   | W 01727        | 50          | 500            | .11                | 13/16      |   |   |
|   | 1-1/8" x 7/8"   |   | W 01737        | 25          | 250            | .12                | 31/32      |   |   |
|   | 1-1/8" x 3/4"   |   | W 01738        | 50          | 500            | .18                | 31/32      |   |   |
|   | 1-1/8" x 5/8"   |   | W 01739        | 25          | 250            | .22                | 31/32      |   |   |
|   | 1-3/8" x 1-1/8" |   | W 01743        | 10          | 200            | .16                | 1-1/32     |   |   |
|   | 1-3/8" x 7/8"   |   | W 01745        | 10          | 200            | .30                | 1-1/32     |   |   |
|   | 1-5/8" x 1-3/8" |   | W 01750        | 10          | 100            | .22                | 1-5/32     |   |   |
|   | 1-5/8" x 1-1/8" |   | W 01751        | 10          | 100            | .41                | 1-5/32     |   |   |
|   | 2-1/8" x 1-5/8" |   | W 01758        | 10          | 100            | .68                | 1-13/32    |   |   |
|   | 2-1/8" x 1-3/8" |   | W 01759        | 5           | 50             | .94                | 1-13/32    |   |   |
|   | 2-5/8" x 2-1/8" |   | W 01767        | -           | 50             | .92                | 1-17/32    |   |   |

TUBE & PIPE

METAL FITTINGS  
& NIPPLES

PLASTIC  
FITTINGS

VALVES

FILTER-DRYERS  
& STRAINERS



**BUSHING • FLUSH**

**COPPER FITTING**

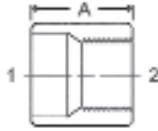

CONNECTION  
**FTG x F**

| I | Size   |          | Part Number | Box Qty. | Master Qty. | Approx. Net.Wt. | Dimensions  |   |   |
|---|--------|----------|-------------|----------|-------------|-----------------|---|---|---|
|   | 2      | 3        |             |          |             |                 | A   | B | C |
|   |        |          |             |          |             |                 | MUELLER STYLE WC-417      ELKHART STYLE 119-3      NIBCO STYLE 9618-3 |   |   |
|   | 5/8"   | x 1/8"   | A 07812*    | 100      | 1,600       | .04             | 17/32   |   |   |
|   | 5/8"   | x 1/4"   | A 07813*    | 50       | 1,200       | .02             | 9/16  |   |   |
|   | 7/8"   | x 3/8"   | A 07814*    | 50       | 600         | .08             | 13/16   |   |   |
|   | 1/8"   | x 1/2"   | A 07815*    | 50       | 300         | .17             | 31/32   |   |   |
|   | 1-3/8" | x 3/4"   | A 07816*    | 10       | 160         | .25             | 1-3/64  |   |   |
|   | 1-5/8" | x 1"     | A 07817*    | 10       | 120         | .34             | 1-5/64  |   |   |
|   | 2-1/8" | x 1-1/2" | A 07819*    | 10       | 60          | .48             | 1-13/32   |   |   |

**CAP**

**COPPER FITTING**



CONNECTION  
**C**

| I | Size   |   | Part Number | Box Qty. | Master Qty. | Approx. Net.Wt. | Dimensions  |   |   |
|---|--------|---|-------------|----------|-------------|-----------------|---|---|---|
|   | 2      | 3 |             |          |             |                 | A   | B | C |
|   |        |   |             |          |             |                 | MUELLER STYLE WC-415      ELKHART STYLE 117      NIBCO STYLE 9617 |   |   |
|   | 1/4"   |   | W 07002     | 50       | 2,000       | .00             | 1/32  |   |   |
|   | 3/8"   |   | W 07004     | 50       | 2,000       | .01             | 3/32  |   |   |
|   | 1/2"   |   | W 07006     | 50       | 1,000       | .01             | 3/32  |   |   |
|   | 5/8"   |   | W 07007     | 50       | 1,000       | .02             | 1/32  |   |   |
|   | 3/4"   |   | W 07008     | 50       | 1,000       | .03             | 1/8   |   |   |
|   | 7/8"   |   | W 07009     | 25       | 1,000       | .04             | 3/64  |   |   |
|   | 1-1/8" |   | W 07011     | 10       | 500         | .07             | 3/64  |   |   |
|   | 1-3/8" |   | W 07012     | 25       | 250         | .11             | 3/64  |   |   |
|   | 1-5/8" |   | W 07013     | 25       | 250         | .18             | 1/16  |   |   |
|   | 2-1/8" |   | W 07014     | -        | 100         | .30             | 1/16  |   |   |
|   | 2-5/8" |   | W 07015     | -        | 50          | .48             | 5/64  |   |   |
|   | 3-1/8" |   | W 07016     | -        | 50          | .73             | 5/64  |   |   |
|   | 3-5/8" |   | W 07017     | -        | 25          | 1.15            | 3/32  |   |   |
|   | 4-1/8" |   | W 07018     | -        | 20          | 1.5             | 7/64  |   |   |

**COUPLING • NO STOP**

**COPPER FITTING**



CONNECTION  
**C x C**

| I | Size   |   | Part Number | Box Qty. | Master Qty. | Approx. Net.Wt. | Dimensions  |   |   |
|---|--------|---|-------------|----------|-------------|-----------------|---|---|---|
|   | 2      | 3 |             |          |             |                 | A   | B | C |
|   |        |   |             |          |             |                 | MUELLER STYLE WC-400NS      ELKHART STYLE 101      NIBCO STYLE 9601 |   |   |
|   | 1/4"   |   | W 01900     | 100      | 3,400       | .01             |   |   |   |
|   | 3/8"   |   | W 01901     | 50       | 1,700       | .01             |   |   |   |
|   | 1/2"   |   | W 01902     | 50       | 1,700       | .01             |   |   |   |
|   | 5/8"   |   | W 01903     | 100      | 1,000       | .03             |   |   |   |
|   | 3/4"   |   | W 01904     | 25       | 375         | .04             |   |   |   |
|   | 7/8"   |   | W 01905     | 50       | 500         | .06             |   |   |   |
|   | 1-1/8" |   | W 01906     | 25       | 250         | .11             |   |   |   |



**COUPLING • NO STOP continued**

**COPPER FITTING**

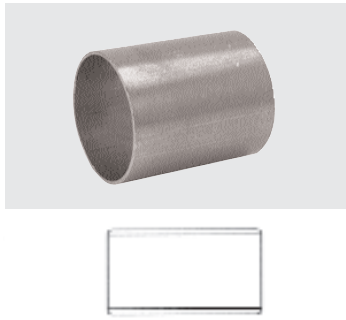

| I      | CONNECTION |   | C x C |               | Part Number | Box Qty. | Master Qty. | Approx. Net.Wt. | Dimensions    |             |   |   |   |
|--------|------------|---|-------|---------------|-------------|----------|-------------|-----------------|---------------|-------------|---|---|---|
|        | Size       | 2 | 3     | MUELLER STYLE |             |          |             |                 | ELKHART STYLE | NIBCO STYLE | A | B | C |
|        |            |   |       | WC-400NS      |             |          |             |                 | 101           | 9601        |   |   |   |
| 1-3/8" |            |   |       |               | W 01907     | 25       | 250         | .15             |               |             |   |   |   |
| 1-5/8" |            |   |       |               | W 01908     | 10       | 100         | .25             |               |             |   |   |   |
| 2-1/8" |            |   |       |               | W 01909     | -        | 75          | .4              |               |             |   |   |   |
| 2-5/8" |            |   |       |               | W 01910     | -        | 50          | .66             |               |             |   |   |   |
| 3-1/8" |            |   |       |               | W 01911     | -        | 25          | 1.03            |               |             |   |   |   |
| 4-1/8" |            |   |       |               | W 01913     | -        | 15          | 2.15            |               |             |   |   |   |

**COUPLING • ROLLED STOP**

**COPPER FITTING**

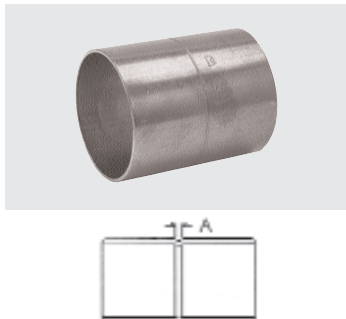

| I      | CONNECTION |   | C x C |               | Part Number | Box Qty. | Master Qty. | Approx. Net.Wt. | Dimensions    |             |   |   |   |
|--------|------------|---|-------|---------------|-------------|----------|-------------|-----------------|---------------|-------------|---|---|---|
|        | Size       | 2 | 3     | MUELLER STYLE |             |          |             |                 | ELKHART STYLE | NIBCO STYLE | A | B | C |
|        |            |   |       | WC-400        |             |          |             |                 | 100-RS        | 9600-RS     |   |   |   |
| 1/8"   |            |   |       |               | W 01000     | 100      | 4,000       | -               | 3/64          |             |   |   |   |
| 3/16"  |            |   |       |               | W 01001     | 100      | 4,000       | -               | 1/16          |             |   |   |   |
| 1/4"   |            |   |       |               | W 01003     | 100      | 4,000       | -               | 1/16          |             |   |   |   |
| 3/8"   |            |   |       |               | W 01009     | 50       | 2,000       | .01             | 1/16          |             |   |   |   |
| 1/2"   |            |   |       |               | W 01017     | 50       | 1,700       | .01             | 1/16          |             |   |   |   |
| 5/8"   |            |   |       |               | W 01022     | 50       | 1,000       | .02             | 1/16          |             |   |   |   |
| 3/4"   |            |   |       |               | W 01028     | 25       | 500         | .05             | 1/16          |             |   |   |   |
| 7/8"   |            |   |       |               | W 01034     | 25       | 500         | .06             | 1/16          |             |   |   |   |
| 1"     |            |   |       |               | W 01040     | 25       | 250         | .10             | 1/16          |             |   |   |   |
| 1-1/8" |            |   |       |               | W 01047     | 10       | 250         | .10             | 1/16          |             |   |   |   |
| 1-3/8" |            |   |       |               | W 01055     | 25       | 250         | .15             | 1/16          |             |   |   |   |
| 1-1/2" |            |   |       |               | W 01062     | -        | 150         | .22             | 1/16          |             |   |   |   |
| 1-5/8" |            |   |       |               | W 01063     | 10       | 100         | .22             | 1/16          |             |   |   |   |
| 2-1/8" |            |   |       |               | W 01072     | -        | 75          | 1.40            | 1/16          |             |   |   |   |
| 2-5/8" |            |   |       |               | W 01082     | -        | 50          | .68             | 3/16          |             |   |   |   |
| 3-1/8" |            |   |       |               | W 01092     | -        | 25          | 1.05            | 3/16          |             |   |   |   |
| 3-5/8" |            |   |       |               | W 10100     | -        | 20          | 1.18            | 3/16          |             |   |   |   |
| 4-1/8" |            |   |       |               | W 10107     | -        | 15          | 2.11            | 3/16          |             |   |   |   |

**COUPLING • STAKED STOP**

**COPPER FITTING**

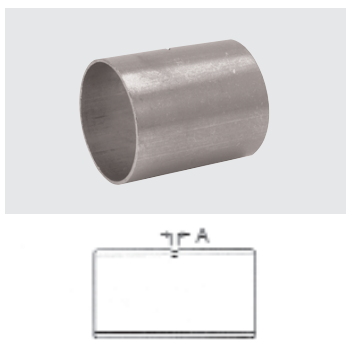

| I     | CONNECTION |   | C x C |               | Part Number | Box Qty. | Master Qty. | Approx. Net.Wt. | Dimensions    |             |   |   |   |
|-------|------------|---|-------|---------------|-------------|----------|-------------|-----------------|---------------|-------------|---|---|---|
|       | Size       | 2 | 3     | MUELLER STYLE |             |          |             |                 | ELKHART STYLE | NIBCO STYLE | A | B | C |
|       |            |   |       | WC-400S       |             |          |             |                 | 100           | 9600-DS     |   |   |   |
| 1/4"  |            |   |       |               | W 10141     | 100      | 4,000       | .01             | 1/16          |             |   |   |   |
| 5/16" |            |   |       |               | W 10142     | 100      | 5,600       | .01             | 1/16          |             |   |   |   |
| 3/8"  |            |   |       |               | W 10143     | 50       | 2,000       | .01             | 1/16          |             |   |   |   |
| 1/2"  |            |   |       |               | W 10144     | 50       | 1,700       | .02             | 1/16          |             |   |   |   |
| 5/8"  |            |   |       |               | W 10145     | 100      | 1,000       | .03             | 1/16          |             |   |   |   |
| 3/4"  |            |   |       |               | W 10157     | 25       | 500         | .04             | 1/16          |             |   |   |   |
| 7/8"  |            |   |       |               | W 10146     | 50       | 500         | .06             | 1/16          |             |   |   |   |





**COUPLING • REDUCING continued**

**COPPER FITTING**

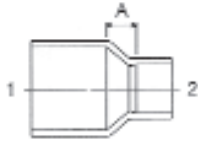

CONNECTION  
**C x C**

MUELLER STYLE  
WC-400R

ELKHART STYLE  
101-R

NIBCO STYLE  
9600

| I | Size<br>2       | 3 | Part<br>Number | Box<br>Qty. | Master<br>Qty. | Approx.<br>Net.Wt. | Dimensions |   |   |
|---|-----------------|---|----------------|-------------|----------------|--------------------|------------|---|---|
|   |                 |   |                |             |                |                    | A          | B | C |
|   | 2-5/8" x 2-1/8" |   | W 01083        | -           | 50             | .65                | 19/32      |   |   |
|   | 2-5/8" x 1-5/8" |   | W 01084        | -           | 50             | .75                | 7/8        |   |   |
|   | 2-5/8" x 1-3/8" |   | W 01085        | -           | 50             | .7                 | 1          |   |   |
|   | 2-5/8" x 1-1/8" |   | W 01086        | -           | 50             | .71                | 1-3/16     |   |   |
|   | 3-1/8" x 2-5/8" |   | W 01093        | -           | 25             | 1.06               | 1/2        |   |   |
|   | 3-1/8" x 2-1/8" |   | W 01094        | -           | 25             | 1.1                | 15/16      |   |   |
|   | 3-1/8" x 1-5/8" |   | W 01095        | -           | 25             | 1.01               | 1-1/4      |   |   |
|   | 3-5/8" x 3-1/8" |   | W 10101        | -           | 25             | 1.22               | 29/64      |   |   |
|   | 4-1/8" x 3-5/8" |   | W 10108        | -           | 20             | 1.87               | 5/8        |   |   |
|   | 4-1/8" x 3-1/8" |   | W 10109        | -           | 20             | .76                | 29/32      |   |   |
|   | 4-1/8" x 2-5/8" |   | W 10110        | -           | 15             | 1.88               | 1-7/16     |   |   |
|   | 4-1/8" x 2-1/8" |   | W 10111        | -           | 20             | 1.97               | 1-5/8      |   |   |

**CROSS • FORGED BRASS**

**COPPER FITTING**

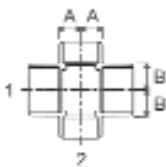

CONNECTION  
**C x C x C x C**

MUELLER STYLE  
WT-603

ELKHART STYLE  
N/A

NIBCO STYLE  
N/A

| I    | Size<br>2 | 3 | Part<br>Number | Box<br>Qty. | Master<br>Qty. | Approx.<br>Net.Wt. | Dimensions |     |   |
|------|-----------|---|----------------|-------------|----------------|--------------------|------------|-----|---|
|      |           |   |                |             |                |                    | A          | B   | C |
| 1/4" |           |   | A 01409*       | 25          | 1,000          | .05                | 1/4        | 1/4 |   |

**45° ELBOW**

**COPPER FITTING**



CONNECTION  
**C x C**

MUELLER STYLE  
WE-504

ELKHART STYLE  
106

NIBCO STYLE  
9606

| I | Size<br>2 | 3 | Part<br>Number | Box<br>Qty. | Master<br>Qty. | Approx.<br>Net.Wt. | Dimensions |   |   |
|---|-----------|---|----------------|-------------|----------------|--------------------|------------|---|---|
|   |           |   |                |             |                |                    | A          | B | C |
|   | 1/4"      |   | W 03005        | 50          | 1,700          | .01                | 3/16       |   |   |
|   | 3/8"      |   | W 03012        | 50          | 1,700          | .01                | 3/16       |   |   |
|   | 1/2"      |   | W 03021        | 25          | 850            | .03                | 13/64      |   |   |
|   | 5/8"      |   | W 03026        | 50          | 500            | .04                | 17/64      |   |   |
|   | 3/4"      |   | W 03030        | 50          | 500            | .06                | 5/16       |   |   |
|   | 7/8"      |   | W 03034        | 25          | 250            | .10                | 23/64      |   |   |
|   | 1-1/8"    |   | W 03044        | 10          | 200            | .18                | 15/32      |   |   |
|   | 1-3/8"    |   | W 03050        | 10          | 100            | .25                | 7/16       |   |   |
|   | 1-5/8"    |   | W 03055        | 10          | 100            | .36                | 1/2        |   |   |
|   | 2-1/8"    |   | W 03059        | 10          | 50             | .6                 | 5/8        |   |   |
|   | 2-5/8"    |   | W 03063        | 5           | 25             | 1                  | 29/32      |   |   |
|   | 3-1/8"    |   | W 03067        | 2           | 20             | 1.53               | 29/32      |   |   |
|   | 3-5/8"    |   | W 03070        | 2           | 10             | 2.81               | 1-9/64     |   |   |
|   | 4-1/8"    |   | W 03073        | -           | 5              | 4.68               | 1-3/16     |   |   |

TUBE & PIPE

METAL FITTINGS & NIPPLES

PLASTIC FITTINGS

VALVES

FILTER-DRYERS & STRAINERS



**45° ELBOW • STREET**

**COPPER FITTING**

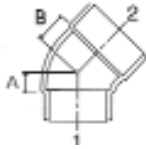

CONNECTION  
**FTG x C**

| I | Size  |   | Part Number | Box Qty. | Master Qty. | Approx. Net.Wt. | Dimensions |         |   |
|---|-------|---|-------------|----------|-------------|-----------------|------------|---------|---|
|   | 2     | 3 |             |          |             |                 | A          | B       | C |
|   |       |   |             |          |             |                 |            |         |   |
|   | 3/8   |   | W 03312     | 100      | 3,400       | .01             | 9/16       | 3/16    |   |
|   | 1/2   |   | W 03321     | 100      | 1,500       | .03             | 21/32      | 13/64   |   |
|   | 5/8   |   | W 03326     | 50       | 500         | .04             | 13/16      | 17/64   |   |
|   | 3/4   |   | W 03330     | 50       | 500         | .06             | 1          | 5/16    |   |
|   | 7/8   |   | W 03334     | 25       | 250         | .10             | 1-11/64    | 23/64   |   |
|   | 1-1/8 |   | W 03344     | 25       | 250         | .15             | 1-7/16     | 15/32   |   |
|   | 1-3/8 |   | W 03350     | 10       | 100         | .24             | 1-13/16    | 25/32   |   |
|   | 1-5/8 |   | W 03355     | 10       | 100         | .33             | 2-5/64     | 15/16   |   |
|   | 2-1/8 |   | W 03359     | 5        | 50          | .61             | 2-3/32     | 5/8     |   |
|   | 2-5/8 |   | W 03363     | 2        | 20          | 1.05            | 3-2/16     | 29/32   |   |
|   | 3-1/8 |   | W 03368     | 2        | 10          | 1.52            | 2-17/32    | 29/32   |   |
|   | 4-1/8 |   | W 03373     | -        | 5           | 3.11            | 4-5/32     | 1-15/16 |   |

**45° ELBOW**

**COPPER FITTING**



CONNECTION  
**FTG x FTG**

| I | Size   |   | Part Number | Box Qty. | Master Qty. | Approx. Net.Wt. | Dimensions |         |   |
|---|--------|---|-------------|----------|-------------|-----------------|------------|---------|---|
|   | 2      | 3 |             |          |             |                 | A          | B       | C |
|   |        |   |             |          |             |                 |            |         |   |
|   | 1/2"   |   | W 03621     | 50       | 1,700       | .02             |            | 21/32   |   |
|   | 5/8"   |   | W 03626     | 50       | 750         | .04             |            | 13/16   |   |
|   | 7/8"   |   | W 03634     | 25       | 250         | .10             |            | 1-11/64 |   |
|   | 1-1/8" |   | W 03644     | 10       | 100         | .18             |            | 1-7/16  |   |

**90° ELBOW • SHORT RADIUS**

**COPPER FITTING**

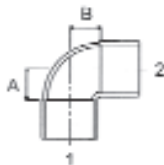

CONNECTION  
**C x C**

| I | Size  |   | Part Number | Box Qty. | Master Qty. | Approx. Net.Wt. | Dimensions |         |   |
|---|-------|---|-------------|----------|-------------|-----------------|------------|---------|---|
|   | 2     | 3 |             |          |             |                 | A          | B       | C |
|   |       |   |             |          |             |                 |            |         |   |
|   | 1/4   |   | W 02003     | 50       | 17,00       | .01             | 3/8        | 3/8     |   |
|   | 3/8   |   | W 02009     | 50       | 1,700       | .02             | 3/8        | 3/8     |   |
|   | 1/2   |   | W 02017     | 50       | 1,000       | .03             | 1/2        | 1/2     |   |
|   | 5/8   |   | W 02022     | 100      | 1,000       | .05             | 19/32      | 19/32   |   |
|   | 3/4   |   | W 02028     | 50       | 500         | .08             | 7/8        | 7/8     |   |
|   | 7/8   |   | W 02034     | 50       | 500         | .11             | 53/64      | 53/64   |   |
|   | 1     |   | W 02040     | 20       | 200         | .22             | 1-1/8      | 1-1/8   |   |
|   | 1-1/8 |   | W 02047     | 25       | 250         | .20             | 1-5/64     | 1-5/64  |   |
|   | 1-3/8 |   | W 02084     | 10       | 100         | .3              | 1-3/32     | 1-3/32  |   |
|   | 1-5/8 |   | W 02085     | 10       | 100         | .42             | 1-7/32     | 1-7/32  |   |
|   | 2-1/8 |   | W 02086     | 10       | 50          | .76             | 1-9/16     | 1-9/16  |   |
|   | 2-5/8 |   | W 02087     | 5        | 25          | 1.19            | 1-13/16    | 1-13/16 |   |
|   | 3-1/8 |   | W 02088     | 5        | 25          | 1.88            | 2-1/16     | 2-1/16  |   |



**90° ELBOW • SHORT RADIUS continued**

**COPPER FITTING**

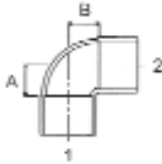

| CONNECTION<br>C x C     |           |   |                        |             |                |                       |                     |         |  |
|-------------------------|-----------|---|------------------------|-------------|----------------|-----------------------|---------------------|---------|--|
| MUELLER STYLE<br>WE-500 |           |   | ELKHART STYLE<br>107-C |             |                | NIBCO STYLE<br>9607-1 |                     |         |  |
| I                       | Size<br>2 | 3 | Part<br>Number         | Box<br>Qty. | Master<br>Qty. | Approx.<br>Net.Wt.    | Dimensions<br>A B C |         |  |
|                         | 3-5/8     |   | W 02089                | 2           | 10             | 2.77                  | 2-13/32             | 2-13/32 |  |
|                         | 4-1/8     |   | W 02090                | 2           | 10             | 4                     | 2-23/32             | 2-23/32 |  |
|                         | 6-1/8     |   | W 02097                | -           | 1              | 13.73                 | 4-13/64             | 4-13/64 |  |

**REDUCING**

|  |                 |  |         |    |     |     |         |         |  |
|--|-----------------|--|---------|----|-----|-----|---------|---------|--|
|  | 3/8" x 1/4"     |  | W 02011 | 50 | 750 | .02 | 7/16    | 11/32   |  |
|  | 1/2" x 3/8"     |  | W 02019 | 50 | 750 | .03 | 9/16    | 7/16    |  |
|  | 5/8" x 1/2"     |  | W 02023 | 50 | 500 | .05 | 5/8     | 1/2     |  |
|  | 5/8" x 3/8"     |  | W 02025 | 50 | 500 | .05 | 21/32   | 7/16    |  |
|  | 3/4" x 5/8"     |  | W 02029 | 50 | 500 | .06 | 11/16   | 19/32   |  |
|  | 3/4" x 1/2"     |  | W 02030 | 50 | 500 | .07 | 13/16   | 1/2     |  |
|  | 7/8" x 3/4"     |  | W 02035 | 50 | 500 | .11 | 29/32   | 7/8     |  |
|  | 7/8" x 5/8"     |  | W 02036 | 50 | 500 | .11 | 59/64   | 21/32   |  |
|  | 7/8" x 1/2"     |  | W 02037 | 50 | 500 | .11 | 15/16   | 5/8     |  |
|  | 1-1/8" x 7/8"   |  | W 02049 | 25 | 250 | .17 | 1       | 7/8     |  |
|  | 1-1/8" x 3/4"   |  | W 02050 | 25 | 250 | .16 | 1       | 7/8     |  |
|  | 1-1/8" x 5/8"   |  | W 02051 | 25 | 250 | .18 | 1-3/16  | 3/4     |  |
|  | 1-1/8" x 1/2"   |  | W 02052 | 25 | 150 | .20 | 1-11/32 | 21/32   |  |
|  | 1-3/8" x 1-1/8" |  | W 02056 | 20 | 200 | .32 | 1-7/16  | 1-1/8   |  |
|  | 1-5/8" x 1-3/8" |  | W 02077 | 5  | 100 | .33 | 1-9/64  | 55/64   |  |
|  | 2-1/8" x 1-5/8" |  | W 02078 | 5  | 50  | .6  | 1-9/16  | 1-13/64 |  |

**90° ELBOW • LONG RADIUS**

**COPPER FITTING**

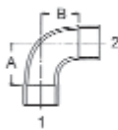

| CONNECTION<br>C x C      |           |   |                        |             |                |                        |                     |         |  |
|--------------------------|-----------|---|------------------------|-------------|----------------|------------------------|---------------------|---------|--|
| MUELLER STYLE<br>WE-500L |           |   | ELKHART STYLE<br>107-L |             |                | NIBCO STYLE<br>9607-LT |                     |         |  |
| I                        | Size<br>2 | 3 | Part<br>Number         | Box<br>Qty. | Master<br>Qty. | Approx.<br>Net.Wt.     | Dimensions<br>A B C |         |  |
|                          | 3/16      |   | W 02701                | 50          | 1,000          | .01                    | 5/16                | 5/16    |  |
|                          | 1/4       |   | W 02715                | 50          | 1,700          | .01                    | 1/2                 | 1/2     |  |
|                          | 5/16      |   | W 02710                | 50          | 1,700          | .01                    | 9/16                | 9/16    |  |
|                          | 3/8       |   | W 02716                | 50          | 1,700          | .02                    | 3/4                 | 3/4     |  |
|                          | 1/2       |   | W 02717                | 50          | 500            | .04                    | 3/4                 | 3/4     |  |
|                          | 5/8       |   | W 02722                | 50          | 500            | .06                    | 7/8                 | 7/8     |  |
|                          | 3/4       |   | W 02728                | 50          | 500            | .09                    | 1-1/8               | 1-1/8   |  |
|                          | 7/8       |   | W 02734                | 25          | 250            | .13                    | 1-3/16              | 1-3/16  |  |
|                          | 1-1/8     |   | W 02747                | 10          | 100            | .27                    | 1-1/2               | 1-1/2   |  |
|                          | 1-1/4     |   | W 02054                | 50          | 50             | .33                    | 1-7/8               | 1-7/8   |  |
|                          | 1-3/8     |   | W 02055                | 10          | 100            | .42                    | 1-7/8               | 1-7/8   |  |
|                          | 1-5/8     |   | W 02063                | 5           | 50             | .6                     | 2-1/4               | 2-1/4   |  |
|                          | 2-1/8     |   | W 02072                | 5           | 25             | 1.23                   | 2-7/8               | 2-7/8   |  |
|                          | 2-5/8     |   | W 02082                | 5           | 25             | 2.05                   | 3-21/32             | 3-21/32 |  |
|                          | 3-1/8     |   | W 02092                | 2           | 10             | 3.13                   | 4-5/8               | 4-5/8   |  |
|                          | 3-5/8     |   | W 02093                | 1           | 5              | 5.53                   | 4-29/32             | 4-29/32 |  |
|                          | 4-1/8     |   | W 02095                | -           | 1              | 7.98                   | 5-7/8               | 5-7/8   |  |



**90° ELBOW • LONG RADIUS continued**

**COPPER FITTING**

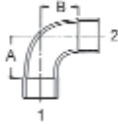

CONNECTION  
**C x C**

MUELLER STYLE  
WE-500L

ELKHART STYLE  
107-L

NIBCO STYLE  
9607-LT

| I               | Size            |   | Part Number | Box Qty. | Master Qty. | Approx. Net.Wt. | Dimensions |         |   |
|-----------------|-----------------|---|-------------|----------|-------------|-----------------|------------|---------|---|
|                 | 2               | 3 |             |          |             |                 | A          | B       | C |
| <b>REDUCING</b> |                 |   |             |          |             |                 |            |         |   |
|                 | 3/8" x 1/4"     |   | W 02711     | 50       | 3,000       | .01             | 19/32      | 15/32   |   |
|                 | 1/2" x 3/8"     |   | W 02719     | 50       | 1,000       | .03             | 41/64      | 39/64   |   |
|                 | 5/8" x 1/2"     |   | W 02723     | 50       | 500         | .04             | 3/4        | 11/16   |   |
|                 | 5/8" x 3/8"     |   | W 02725     | 50       | 1,000       | .03             | 11/16      | 5/8     |   |
|                 | 7/8" x 3/8"     |   | W 02735     | 25       | 250         | .12             | 1-5/32     | 1-1/16  |   |
|                 | 7/8" x 5/8"     |   | W 02736     | 50       | 500         | .09             | 1-7/8      | 1-7/8   |   |
|                 | 1-1/8" x 7/8"   |   | W 02749     | 10       | 200         | .17             | 1-1/4      | 1-9/64  |   |
|                 | 1-1/8" x 5/8"   |   | W 02751     | 25       | 250         | .12             | 1-1/8      | 7/8     |   |
|                 | 1-3/8" x 1-1/8" |   | W 02756     | 10       | 100         | .31             | 1-5/8      | 1-15/32 |   |
|                 | 1-5/8" x 1-3/8" |   | W 02064     | 5        | 50          | .44             | 1-59/64    | 1-7/8   |   |
|                 | 1-5/8" x 1-1/8" |   | W 02065     | 5        | 50          | .52             | 2-1/8      | 1-5/8   |   |
|                 | 1-5/8" x 7/8"   |   | W 02067     | 5        | 50          | .51             | 2-3/64     | 1-3/8   |   |
|                 | 2-1/8" x 1-5/8" |   | W 02073     | 2        | 20          | .98             | 2-7/16     | 2-11/64 |   |
|                 | 2-1/8" x 1-3/8" |   | W 02074     | 2        | 20          | .94             | 2-1/2      | 2-1/8   |   |
|                 | 2-1/8" x 1-1/8" |   | W 02075     | 2        | 20          | .97             | 2-1/2      | 2-3/32  |   |
|                 | 2-5/8" x 2-1/8" |   | W 02083     | 2        | 20          | 1.53            | 2-31/32    | 2-31/32 |   |

**90° ELBOW • SHORT RADIUS STREET**

**COPPER FITTING**

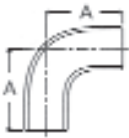

CONNECTION  
**FTG x C**

MUELLER STYLE  
WE-503

ELKHART STYLE  
107-C-2

NIBCO STYLE  
9607-2

| I | Size  |   | Part Number | Box Qty. | Master Qty. | Approx. Net.Wt. | Dimensions |         |   |
|---|-------|---|-------------|----------|-------------|-----------------|------------|---------|---|
|   | 2     | 3 |             |          |             |                 | A          | B       | C |
|   | 1/4   |   | W 02305     | 50       | 1,700       | .01             | 3/4        | 3/8     |   |
|   | 3/8   |   | W 02312     | 50       | 1,700       | .02             | 3/4        | 3/8     |   |
|   | 1/2   |   | W 02321     | 50       | 750         | .03             | 15/16      | 1/2     |   |
|   | 5/8   |   | W 02326     | 50       | 500         | .05             | 1-5/32     | 19/32   |   |
|   | 3/4   |   | W 02330     | 25       | 250         | .09             | 1-7/16     | 7/8     |   |
|   | 7/8   |   | W 02334     | 25       | 250         | .11             | 1-5/8      | 13/16   |   |
|   | 1-1/8 |   | W 02344     | 25       | 250         | .21             | 2-1/32     | 1-1/16  |   |
|   | 1-3/8 |   | W 02384     | 25       | 125         | .29             | 2-5/64     | 1-1/16  |   |
|   | 1-5/8 |   | W 02385     | 10       | 100         | .44             | 2-3/8      | 1-7/32  |   |
|   | 2-1/8 |   | W 02386     | 10       | 50          | .86             | 2-25/32    | 1-3/8   |   |
|   | 2-5/8 |   | W 02387     | 5        | 25          | 1.23            | 3-11/32    | 1-13/16 |   |
|   | 3-1/8 |   | W 02388     | 2        | 20          | 1.94            | 3-25/32    | 2-1/16  |   |
|   | 3-5/8 |   | W 02389     | 1        | 10          | 2.78            | 4-3/8      | 2-23/64 |   |
|   | 4-1/8 |   | W 02390     | 2        | 10          | 4.03            | 4-15/16    | 2-23/64 |   |

**90° ELBOW • LONG RADIUS STREET**

**COPPER FITTING**

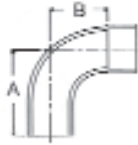

CONNECTION  
**FTG x C**

MUELLER STYLE  
WE-503L

ELKHART STYLE  
107-L-2

NIBCO STYLE  
9607-2-LT

| I | Size   |   | Part Number | Box Qty. | Master Qty. | Approx. Net.Wt. | Dimensions |         |   |
|---|--------|---|-------------|----------|-------------|-----------------|------------|---------|---|
|   | 2      | 3 |             |          |             |                 | A          | B       | C |
|   | 3/8"   |   | W 02809     | 50       | 1,700       | .02             | 1-1/8      | 3/4     |   |
|   | 1/2"   |   | W 02817     | 50       | 500         | .04             | 1-3/16     | 3/4     |   |
|   | 5/8"   |   | W 02822     | 50       | 500         | .06             | 1-3/8      | 7/8     |   |
|   | 3/4"   |   | W 02828     | 25       | 250         | .09             | 1-13/16    | 1-1/8   |   |
|   | 7/8"   |   | W 02834     | 25       | 250         | .13             | 2          | 1-3/16  |   |
|   | 1-1/8" |   | W 02847     | 10       | 100         | .27             | 2-15/32    | 1-1/2   |   |
|   | 1-3/8" |   | W 02350     | 10       | 100         | .42             | 2-29/32    | 1-7/8   |   |
|   | 1-5/8" |   | W 02355     | 5        | 50          | .60             | 3-7/16     | 2-1/4   |   |
|   | 2-1/8" |   | W 02359     | 5        | 25          | 1.23            | 4-9/32     | 2-7/8   |   |
|   | 2-5/8" |   | W 02363     | 5        | 25          | 2.08            | 5-5/32     | 3-21/32 |   |
|   | 3-1/8" |   | W 02368     | 2        | 10          | 3.12            | 6-9/32     | 4-5/8   |   |
|   | 3-5/8" |   | W 02393     | 1        | 5           | 5.52            | 7-7/32     | 5-1/4   |   |
|   | 4-1/8" |   | W 02395     | -        | 1           | 8.07            | 8-3/32     | 5-7/8   |   |

**90° ELBOW • SHORT RADIUS**

**COPPER FITTING**

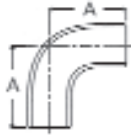

CONNECTION  
**FTG x FTG**

MUELLER STYLE  
WE-506

ELKHART STYLE  
105-C

NIBCO STYLE  
9607-2-2

| I | Size   |   | Part Number | Box Qty. | Master Qty. | Approx. Net.Wt. | Dimensions |   |   |
|---|--------|---|-------------|----------|-------------|-----------------|------------|---|---|
|   | 2      | 3 |             |          |             |                 | A          | B | C |
|   | 3/8"   |   | W 02612     | 50       | 1,700       | .02             | 3/4        |   |   |
|   | 1/2"   |   | W 02621     | 50       | 750         | .03             | 15/16      |   |   |
|   | 5/8"   |   | W 02626     | 50       | 500         | .05             | 1-5/32     |   |   |
|   | 7/8"   |   | W 02634     | 25       | 250         | .11             | 1-5/8      |   |   |
|   | 1-1/8" |   | W 02644     | 10       | 100         | .22             | 2-1/32     |   |   |
|   | 1-3/8" |   | W 02684     | 10       | 100         | .31             | 2-5/64     |   |   |
|   | 1-5/8" |   | W 02685     | 5        | 50          | .43             | 2-3/8      |   |   |
|   | 2-1/8" |   | W 02686     | 1        | 10          | .79             | 2-31/32    |   |   |
|   | 2-5/8" |   | W 02687     | 1        | 10          | 1.25            | 3-21/64    |   |   |
|   | 3-1/8" |   | W 02688     | 1        | 10          | 2.08            | 3-25/32    |   |   |
|   | 3-5/8" |   | W 02689     | 1        | 10          | 2.63            | 4-11/32    |   |   |
|   | 4-1/8" |   | W 02690     | 1        | 5           | 3.88            | 4-7/8      |   |   |

**90° ELBOW • LONG RADIUS**

**COPPER FITTING**

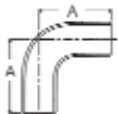

CONNECTION  
**FTG x FTG**

MUELLER STYLE  
WE-506L

ELKHART STYLE  
105-L

NIBCO STYLE  
607-2-2-LT

| I | Size   |   | Part Number | Box Qty. | Master Qty. | Approx. Net.Wt. | Dimensions |   |   |
|---|--------|---|-------------|----------|-------------|-----------------|------------|---|---|
|   | 2      | 3 |             |          |             |                 | A          | B | C |
|   | 1-3/8" |   | W 02650     | 5        | 50          | .44             | 2-29/32    |   |   |
|   | 1-5/8" |   | W 02655     | 5        | 50          | .63             | 3-7/16     |   |   |
|   | 2-1/8" |   | W 02659     | 1        | 10          | 1.23            | 4-23/64    |   |   |



**90° ELBOW • FORGED BRASS**

**COPPER FITTING**

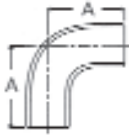

CONNECTION  
**C x F**

| I | Size          |   | Part Number | Box Qty. | Master Qty. | Approx. Net.Wt. | Dimensions |        |   |
|---|---------------|---|-------------|----------|-------------|-----------------|------------|--------|---|
|   | 2             | 3 |             |          |             |                 | A          | B      | C |
|   |               |   |             |          |             |                 |            |        |   |
|   | 1/4" x 1/4"   |   | W 02206*    | 50       | 450         | .10             | 1/2        | 3/4    |   |
|   | 1/4" x 1/8"   |   | W 02207*    | 50       | 800         | .07             | 7/16       | 25/32  |   |
|   | 3/8" x 3/8"   |   | W 02214*    | 50       | 600         | .10             | 9/16       | 45/64  |   |
|   | 3/8" x 1/4"   |   | W 02215*    | 50       | 600         | .09             | 1/2        | 3/4    |   |
|   | 3/8" x 1/8"   |   | W 02216*    | 50       | 700         | .08             | 1/4        | 29/32  |   |
|   | 1/2" x 1/2"   |   | W 02224*    | —        | 225         | .24             | 21/32      | 59/64  |   |
|   | 1/2" x 3/8"   |   | W 02225*    | 25       | 300         | .11             | 1/2        | 45/64  |   |
|   | 1/2" x 1/4"   |   | W 02226*    | 25       | 350         | .10             | 7/16       | 3/4    |   |
|   | 5/8" x 3/4"   |   | W 02230*    | 10       | 150         | .29             | 21/32      | 1      |   |
|   | 5/8" x 1/2"   |   | W 02231*    | 10       | 240         | .25             | 1/2        | 15/16  |   |
|   | 5/8" x 3/8"   |   | W 02232*    | 10       | 240         | .17             | 37/64      | 25/32  |   |
|   | 3/4" x 3/4"   |   | W 02238*    | 10       | 150         | .28             | 21/32      | 1-3/64 |   |
|   | 3/4" x 1/2"   |   | W 02239*    | 10       | 140         | .26             | 21/32      | 1-1/32 |   |
|   | 7/8" x 3/4"   |   | W 02246*    | 10       | 150         | .28             | 21/32      | 1-3/64 |   |
|   | 7/8" x 1/2"   |   | W 02247*    | 10       | 150         | .23             | 33/64      | 1-3/32 |   |
|   | 1-1/8" x 3/4" |   | W 02264*    | 10       | 90          | .44             | 23/32      | 1-7/32 |   |

**90° ELBOW • FORGED BRASS**

**COPPER FITTING**

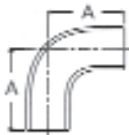

CONNECTION  
**C x M**

| I | Size          |   | Part Number | Box Qty. | Master Qty. | Approx. Net.Wt. | Dimensions |       |   |
|---|---------------|---|-------------|----------|-------------|-----------------|------------|-------|---|
|   | 2             | 3 |             |          |             |                 | A          | B     | C |
|   |               |   |             |          |             |                 |            |       |   |
|   | 1/4" x 3/8"   |   | W 02105*    | 50       | 450         | .11             | 1          | 29/64 |   |
|   | 1/4" x 1/4"   |   | W 02106*    | 50       | 700         | .07             | 7/8        | 3/8   |   |
|   | 1/4" x 1/8"   |   | W 02107*    | 50       | 1,200       | .04             | 3/4        | 1/8   |   |
|   | 3/8" x 1/2"   |   | W 02113*    | 25       | 350         | .16             | 1-1/4      | 15/32 |   |
|   | 3/8" x 3/8"   |   | W 02114*    | 50       | 450         | .10             | 1          | 29/64 |   |
|   | 3/8" x 1/4"   |   | W 02115*    | 50       | 800         | .06             | 7/8        | 1/4   |   |
|   | 3/8" x 1/8"   |   | W 02116*    | 50       | 800         | .06             | 3/4        | 19/64 |   |
|   | 1/2" x 3/4"   |   | W 02123*    | 10       | 140         | .22             | 1-1/2      | 9/16  |   |
|   | 1/2" x 1/2"   |   | W 02124*    | 25       | 300         | .13             | 1-1/4      | 5/16  |   |
|   | 1/2" x 3/8"   |   | W 02125*    | 25       | 400         | .10             | 1          | 5/16  |   |
|   | 1/2" x 1/4"   |   | W 02126*    | 25       | 400         | .09             | 1          | 1/4   |   |
|   | 5/8" x 3/4"   |   | W 02130*    | 10       | 160         | .22             | 1-1/2      | 9/16  |   |
|   | 5/8" x 1/2"   |   | W 02131*    | 10       | 240         | .17             | 1-1/4      | 17/32 |   |
|   | 5/8" x 3/8"   |   | W 02132*    | 10       | 240         | .16             | 1-1/8      | 7/16  |   |
|   | 3/4" x 1"     |   | W 02137*    | 10       | 140         | .90             | 1-11/16    | 15/32 |   |
|   | 3/4" x 3/4"   |   | W 02138*    | 10       | 210         | .22             | 1-1/2      | 15/32 |   |
|   | 7/8" x 3/4"   |   | W 02146*    | 10       | 150         | .31             | 1-1/2      | 9/16  |   |
|   | 7/8" x 1/2"   |   | W 02147*    | 15       | 180         | .24             | 1-13/32    | 33/64 |   |
|   | 7/8" x 3/8"   |   | W 02148*    | 10       | 120         | .24             | 1-13/64    | 33/64 |   |
|   | 1-1/8" x 1"   |   | W 02163*    | 10       | 90          | .45             | 1-23/32    | 23/32 |   |
|   | 1-1/8" x 3/4" |   | W 02164*    | 10       | 120         | .44             | 1-17/32    | 23/32 |   |



**FITTING REDUCER**

**COPPER FITTING**

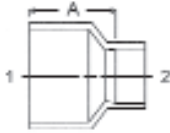
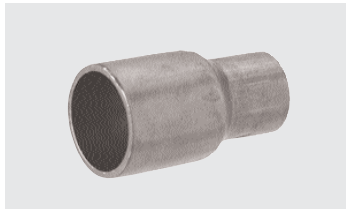

CONNECTION  
**FTG x C**

MUELLER STYLE  
WC-403

ELKHART STYLE  
118

NIBCO STYLE  
9600-2

| I | Size<br>2       | 3 | Part<br>Number | Box<br>Qty. | Master<br>Qty. | Approx.<br>Net.Wt. | Dimensions |   |   |
|---|-----------------|---|----------------|-------------|----------------|--------------------|------------|---|---|
|   |                 |   |                |             |                |                    | A          | B | C |
|   | 1/4" x 1/8"     |   | W 01302        | 50          | 2,000          | .01                | 17/32      |   |   |
|   | 3/8" x 1/4"     |   | W 01306        | 50          | 1,700          | .01                | 3/8        |   |   |
|   | 1/2" x 3/8"     |   | W 01312        | 50          | 1,700          | .02                | 5/8        |   |   |
|   | 1/2" x 1/4"     |   | W 01314        | 50          | 1,700          | .01                | 19/32      |   |   |
|   | 5/8" x 1/2"     |   | W 01315        | 50          | 750            | .03                | 3/4        |   |   |
|   | 5/8" x 3/8"     |   | W 01317        | 50          | 1,700          | .02                | 25/32      |   |   |
|   | 3/4" x 5/8"     |   | W 01320        | 100         | 1,000          | .04                | 7/8        |   |   |
|   | 3/4" x 1/2"     |   | W 01321        | 100         | 900            | .04                | 29/32      |   |   |
|   | 3/4" x 3/8"     |   | W 01322        | 100         | 900            | .04                | 7/8        |   |   |
|   | 7/8" x 3/4"     |   | W 01325        | 50          | 500            | .06                | 31/32      |   |   |
|   | 7/8" x 5/8"     |   | W 01326        | 50          | 500            | .06                | 61/64      |   |   |
|   | 7/8" x 1/2"     |   | W 01327        | 50          | 500            | .06                | 1-1/8      |   |   |
|   | 1-1/8" x 7/8"   |   | W 01337        | 25          | 250            | .11                | 1-7/64     |   |   |
|   | 1-1/8" x 3/4"   |   | W 01338        | 25          | 250            | .01                | 1-1/4      |   |   |
|   | 1-1/8" x 5/8"   |   | W 01339        | 25          | 250            | .10                | 1-11/32    |   |   |
|   | 1-1/8" x 1/2"   |   | W 01340        | 20          | 200            | .01                | 1-3/8      |   |   |
|   | 1-3/8" x 1-1/8" |   | W 01343        | 10          | 100            | .17                | 1-7/32     |   |   |
|   | 1-3/8" x 7/8"   |   | W 01345        | 10          | 100            | .17                | 1-11/32    |   |   |
|   | 1-3/8" x 5/8"   |   | W 01347        | 10          | 100            | .16                | 1-1/2"     |   |   |
|   | 1-5/8" x 1-3/8" |   | W 01350        | 10          | 100            | .23                | 1-13/32    |   |   |
|   | 1-5/8" x 1-1/8" |   | W 01351        | 10          | 100            | .24                | 1-17/32    |   |   |
|   | 1-5/8" x 7/8"   |   | W 01353        | 10          | 100            | .23                | 1-11/16    |   |   |
|   | 1-5/8" x 5/8"   |   | W 01355        | 10          | 100            | .22                | 1-3/4      |   |   |
|   | 2-1/8" x 1-5/8" |   | W 01358        | -           | 100            | .44                | 1-27/32    |   |   |
|   | 2-1/8" x 1-3/8" |   | W 01359        | -           | 100            | .43                | 2-1/32     |   |   |
|   | 2-1/8" x 1-1/8" |   | W 01360        | -           | 100            | .45                | 2-1/8      |   |   |
|   | 2-1/8" x 7/8"   |   | W 01362        | -           | 100            | .43                | 2-3/16     |   |   |
|   | 2-1/8" x 5/8"   |   | W 01364        | -           | 100            | .42                | 2-5/8      |   |   |
|   | 2-5/8" x 2-1/8" |   | W 01367        | -           | 50             | .62                | 2-1/32     |   |   |
|   | 2-5/8" x 1-5/8" |   | W 01368        | -           | 50             | .57                | 2-7/32     |   |   |
|   | 2-5/8" x 1-3/8" |   | W 01369        | -           | 50             | .62                | 2-15/32    |   |   |
|   | 2-5/8" x 1-1/8" |   | W 01370        | -           | 50             | .63                | 2-7/8      |   |   |
|   | 3-1/8" x 2-5/8" |   | W 01376        | -           | 25             | 1                  | 2-1/32     |   |   |
|   | 3-1/8" x 2-1/8" |   | W 01377        | -           | 25             | .89                | 2-1/2      |   |   |
|   | 3-1/8" x 1-5/8" |   | W 01378        | -           | 50             | .92                | 2-21/32    |   |   |
|   | 3-1/8" x 1-3/8" |   | W 01379        | -           | 50             | 1.01               | 3          |   |   |
|   | 3-5/8" x 3-1/8" |   | W 01381        | -           | 20             | 1.28               | 2-11/32    |   |   |
|   | 3-5/8" x 2-5/8" |   | W 01382        | -           | 20             | 1.37               | 1-39/64    |   |   |
|   | 3-5/8" x 2-1/8" |   | W 01383        | -           | 20             | 1.47               | 3-3/32     |   |   |
|   | 4-1/8" x 3-5/8" |   | W 01386        | -           | 20             | 1.74               | 2-1/2      |   |   |
|   | 4-1/8" x 3-1/8" |   | W 01387        | -           | 15             | 1.77               | 2-31/32    |   |   |
|   | 4-1/8" x 2-5/8" |   | W 01388        | -           | 15             | 1.83               | 3-35/64    |   |   |
|   | 4-1/8" x 2-1/8" |   | W 01389        | -           | 15             | 1.86               | 3-21/32    |   |   |

TUBE & PIPE

METAL FITTINGS & NIPPLES

PLASTIC FITTINGS

VALVES

FILTER-DRYERS & STRAINERS



**P-TRAPS • SUCTION LINE**

**COPPER FITTING**

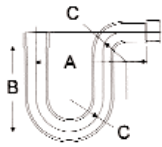

CONNECTION  
**C x C**

MUELLER STYLE  
WE-554P

ELKHART STYLE  
123

NIBCO STYLE  
9698

| I | Size   |   | Part Number | Box Qty. | Master Qty. | Approx. Net.Wt. | Dimensions |      |      |
|---|--------|---|-------------|----------|-------------|-----------------|------------|------|------|
|   | 2      | 3 |             |          |             |                 | A          | B    | C    |
|   | 5/8"   |   | W 60999     | 10       | 50          | .38             | 6.00       | 5.55 | 1.50 |
|   | 3/4"   |   | W 61008     | 10       | 50          | .51             | 6.00       | 6.13 | 1.50 |
|   | 7/8"   |   | W 61000     | 5        | 25          | .63             | 6.00       | 6.13 | 1.50 |
|   | 1-1/8" |   | W 61001     | 3        | 15          | .87             | 5.73       | 6.13 | 1.50 |
|   | 1-3/8" |   | W 61002     | 4        | 20          | 1.16            | 6.56       | 5.28 | 1.88 |
|   | 1-5/8" |   | W 61003     | 4        | 1           | 2.28            | 8.66       | 7.90 | 2.50 |
|   | 2-1/8" |   | W 61009     | 1        | 3           | 3.87            | 9.90       | 8.66 | 3.00 |

**PLUG • FITTING**

**COPPER FITTING**

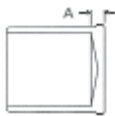

CONNECTION  
**FTG**

MUELLER STYLE  
WC-416

ELKHART STYLE  
116

NIBCO STYLE  
9616

| I | Size   |   | Part Number | Box Qty. | Master Qty. | Approx. Net.Wt. | Dimensions |   |   |
|---|--------|---|-------------|----------|-------------|-----------------|------------|---|---|
|   | 2      | 3 |             |          |             |                 | A          | B | C |
|   | 1/4"   |   | A 01402     | 50       | 500         | .01             | 1/8        |   |   |
|   | 3/8"   |   | A 01422     | 100      | 4,000       | .01             | 1/8        |   |   |
|   | 1/2"   |   | A 01392     | 50       | 2,000       | .02             | 1/8        |   |   |
|   | 5/8"   |   | A 01504     | 50       | 1,200       | .03             | 1/8        |   |   |
|   | 3/4"   |   | A 02273     | 10       | 560         | .05             | 1/8        |   |   |
|   | 7/8"   |   | A 01529     | 50       | 600         | .07             | 1/8        |   |   |
|   | 1-1/8" |   | A 01556     | 25       | 375         | .12             | 1/8        |   |   |
|   | 1-3/8" |   | A 01590     | 180      | 180         | .20             | 1/8        |   |   |
|   | 1-5/8" |   | A 01628     | 10       | 120         | .28             | 1/8        |   |   |

**RETURN BEND**

**COPPER FITTING**

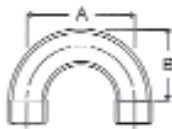

CONNECTION  
**C x C**

MUELLER STYLE  
WE-512

ELKHART STYLE  
138

NIBCO STYLE  
9638

| I | Size |          | Part Number | Box Qty. | Master Qty. | Approx. Net.Wt. | Dimensions |         |   |
|---|------|----------|-------------|----------|-------------|-----------------|------------|---------|---|
|   | 2    | 3        |             |          |             |                 | A          | B       | C |
|   | 3/8" | 4-1/2"   | W 06025     | 25       | 150         | .01             | 4-1/2      | 2-7/16  |   |
|   | 3/8" | 1-1/2"   | W 06020     | 25       | 850         | .02             | 1-1/2      | 15/16   |   |
|   | 1/2" | 6"       | W 06048     | -        | 100         | .21             | 6          | 3-1/4   |   |
|   | 1/2" | 4"       | W 06045     | -        | 200         | .14             | 4          | 2-5/16  |   |
|   | 1/2" | 3"       | W 06041     | 25       | 225         | .11             | 3          | 1-3/4   |   |
|   | 1/2" | 2"       | W 06036     | 50       | 300         | .06             | 2          | 1-1/4   |   |
|   | 1/2" | 1-29/32" | W 06035     | 50       | 300         | .08             | 1-29/32    | 1-13/64 |   |
|   | 1/2" | 1-1/2"   | W 06032     | 50       | 500         | .06             | 1-1/2      | 1       |   |
|   | 5/8" | 6"       | W 06069     | 5        | 30          | .30             | 6          | 3-5/16  |   |
|   | 5/8" | 3-3/8"   | W 06062     | 10       | 100         | .18             | 3-3/8      | 2       |   |
|   | 5/8" | 3"       | W 06060     | 25       | 150         | .16             | 3          | 1-13/16 |   |
|   | 5/8" | 2-1/2"   | W 06058     | 25       | 250         | .14             | 2-1/2      | 1-9/16  |   |
|   | 5/8" | 2-1/4"   | W 06056     | 25       | 250         | .13             | 2-1/4      | 1-1/2   |   |
|   | 5/8" | 1-7/8"   | W 06053     | 25       | 250         | .11             | 1-7/8      | 1-1/4   |   |
|   | 5/8" | 1-9/16"  | W 06051     | 25       | 250         | .10             | 1-9/16     | 1-3/32  |   |



**RETURN BEND continued**

**COPPER FITTING**



CONNECTION  
**C x C**

MUELLER STYLE  
WE-512

ELKHART STYLE  
138

NIBCO STYLE  
9638

| I | Size   |          | Part Number | Box Qty. | Master Qty. | Approx. Net.Wt. | Dimensions |         |   |
|---|--------|----------|-------------|----------|-------------|-----------------|------------|---------|---|
|   | 2      | 3        |             |          |             |                 | A          | B       | C |
|   | 3/4"   | × 4"     | W 06084     | –        | 120         | .25             | 4          | 1-7/8   |   |
|   | 3/4"   | × 3-3/8" | W 06081     | 10       | 90          | .24             | 3-3/8      | 2-1/16  |   |
|   | 3/4"   | × 2-1/2" | W 06077     | 10       | 100         | .17             | 2-1/2      | 1-5/8   |   |
|   | 3/4"   | × 2-1/8" | W 06074     | 10       | 100         | .15             | 2-1/8      | 1-7/16  |   |
|   | 3/4"   | × 2"     | W 06073     | 10       | 100         | .16             | 2          | 1-3/8   |   |
|   | 7/8"   | × 12"    | W 06099     | 15       | 15          | .88             | 12         | 6-7/16  |   |
|   | 7/8"   | × 3-3/8" | W 06095     | 10       | 100         | .29             | 3-3/8      | 2-1/8   |   |
|   | 7/8"   | × 2-1/2" | W 06092     | 10       | 100         | .23             | 2-1/2      | 1-11/16 |   |
|   | 1-1/8" | × 3-1/4" | W 60111     | 5        | 50          | .49             | 3-1/4      | 2-3/16  |   |
|   | 7/8"   | × 3"     | W 60110     | 5        | 50          | .47             | 3          | 2-1/16  |   |
|   | 1-3/8" | × 3-3/4" | W 60121     | 5        | 50          | .65             | 3-3/4      | 2-9/16  |   |
|   | 1-5/8" | × 4-1/2" | W 60131     | –        | 25          | 1               | 4-1/2      | 3-1/6   |   |
|   | 2-1/8" | × 5-1/2" | W 60140     | 1        | 15          | 1.92            | 5-1/2      | 3-13/16 |   |

**TEE**

**COPPER FITTING**



CONNECTION  
**C x C x C**

MUELLER STYLE  
WT-600

ELKHART STYLE  
111

NIBCO STYLE  
9611

| I | Size  |   | Part Number | Box Qty. | Master Qty. | Approx. Net.Wt. | Dimensions |         |         |
|---|-------|---|-------------|----------|-------------|-----------------|------------|---------|---------|
|   | 2     | 3 |             |          |             |                 | A          | B       | C       |
|   | 3/16  |   | W 40302     | 50       | 2,000       | .01             | 7/64       | 7/64    | 25/32   |
|   | 1/4   |   | W 40306     | 100      | 2,400       | .01             | 5/32       | 5/32    | 5/32    |
|   | 5/16  |   | W 40313     | 50       | 1,700       | .01             | 13/64      | 13/64   | 3/16    |
|   | 3/8   |   | W 04000     | 50       | 1,700       | .02             | 13/64      | 13/64   | 3/16    |
|   | 1/2   |   | W 04001     | 50       | 500         | .04             | 17/64      | 17/64   | 1/4     |
|   | 5/8   |   | W 04006     | 50       | 500         | .06             | 21/64      | 21/64   | 21/64   |
|   | 3/4   |   | W 04017     | 25       | 250         | .12             | 13/32      | 13/32   | 25/64   |
|   | 7/8   |   | W 04031     | 25       | 250         | .17             | 15/32      | 15/32   | 29/64   |
|   | 1-1/8 |   | W 04048     | 10       | 100         | .31             | 37/64      | 37/64   | 9/16    |
|   | 1-3/8 |   | W 04068     | 5        | 50          | .42             | 23/32      | 23/32   | 45/64   |
|   | 1-5/8 |   | W 04084     | 5        | 50          | .6              | 53/64      | 53/64   | 53/64   |
|   | 2-1/8 |   | W 40102     | 5        | 25          | 1.14            | 1-3/32     | 1-3/32  | 1-3/32  |
|   | 2-5/8 |   | W 40123     | 2        | 20          | 1.72            | 1-5/16     | 1-5/16  | 1-3/8   |
|   | 3-1/8 |   | W 40152     | 2        | 10          | 2.77            | 1-19/32    | 1-19/32 | 1-5/8   |
|   | 3-5/8 |   | W 40190     | 1        | 5           | 5.66            | 1-15/16    | 1-15/16 | 1-55/64 |
|   | 4-1/8 |   | W 40200     | 1        | 5           | 5.99            | 2-1/8      | 2-1/8   | 2-1/8   |
|   | 5-1/8 |   | W 40400     | –        | 1           | 12.38           | 2-45/64    | 2-45/64 | 2-47/64 |
|   | 6-1/8 |   | W 40500     | –        | 1           | 20.85           | 3-1/16     | 3-1/16  | 3-1/4   |

**REDUCING**

|  |       |         |         |         |    |       |     |       |       |       |
|--|-------|---------|---------|---------|----|-------|-----|-------|-------|-------|
|  | 1/4"  | × 1/4"  | × 3/8"  | W 40368 | 50 | 750   | .03 | 33/64 | 33/64 | 3/16  |
|  | 1/4"  | × 1/4"  | × 3/16" | W 40308 | 50 | 2,000 | .01 | 15/32 | 15/32 | 11/32 |
|  | 5/16" | × 5/16" | × 3/8"  | W 40334 | 50 | 750   | .03 | 15/32 | 15/32 | 7/32  |
|  | 3/8"  | × 3/8"  | × 5/8"  | W 04016 | 50 | 500   | .08 | 13/32 | 13/32 | 15/64 |
|  | 3/8"  | × 3/8"  | × 1/2"  | W 04005 | 50 | 500   | .04 | 1/4   | 1/4   | 15/64 |
|  | 3/8"  | × 3/8"  | × 1/4"  | W 40324 | 50 | 1,700 | .02 | 5/32  | 5/32  | 7/32  |
|  | 3/8"  | × 1/4"  | × 3/8"  | W 40330 | 50 | 500   | .02 | 13/64 | 33/64 | 3/16  |
|  | 3/8"  | × 1/4"  | × 1/4"  | W 40332 | 50 | 1,700 | .02 | 5/32  | 3/8   | 7/32  |



**TEE continued**

**COPPER FITTING**

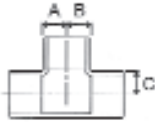

CONNECTION  
**C x C x C**

| I               | MUELLER STYLE<br>WT-600  |   | ELKHART STYLE<br>111 |          | NIBCO STYLE<br>9611 |                 | Dimensions |         |        |
|-----------------|--------------------------|---|----------------------|----------|---------------------|-----------------|------------|---------|--------|
|                 | Size                     | 3 | Part Number          | Box Qty. | Master Qty.         | Approx. Net.Wt. | A          | B       | C      |
| <b>REDUCING</b> |                          |   |                      |          |                     |                 |            |         |        |
|                 | 1/2" x 1/2" x 5/8"       |   | W 04015              | 50       | 500                 | .09             | 21/32      | 21/32   | 21/64  |
|                 | 1/2" x 1/2" x 3/8"       |   | W 04002              | 50       | 500                 | .04             | 7/32       | 7/32    | 9/32   |
|                 | 1/2" x 1/2" x 1/4"       |   | W 40350              | 50       | 500                 | .04             | 7/32       | 7/32    | 19/32  |
|                 | 1/2" x 3/8" x 1/2"       |   | W 04003              | 50       | 500                 | .05             | 17/64      | 9/16    | 1/4    |
|                 | 1/2" x 3/8" x 3/8"       |   | W 04004              | 50       | 500                 | .04             | 7/32       | 1/2     | 9/32   |
|                 | 1/2" x 3/8" x 1/4"       |   | W 40358              | 50       | 750                 | .04             | 7/32       | 33/64   | 19/32  |
|                 | 1/2" x 1/4" x 1/2"       |   | W 40363              | 50       | 750                 | .05             | 17/64      | 39/64   | 1/4    |
|                 | 1/2" x 1/4" x 3/8"       |   | W 40364              | 50       | 750                 | .04             | 7/32       | 21/32   | 19/64  |
|                 | 1/2" x 1/4" x 1/4"       |   | W 40366              | 50       | 450                 | .05             | 7/32       | 21/32   | 23/32  |
|                 | 5/8" x 5/8" x 1-1/8"     |   | W 04067              | 10       | 100                 | .35             | 1-5/16     | 1-5/16  | 5/8    |
|                 | 5/8" x 5/8" x 7/8"       |   | W 04047              | 25       | 250                 | .11             | 15/32      | 15/32   | 21/64  |
|                 | 5/8" x 5/8" x 3/4"       |   | W 04029              | 25       | 250                 | .10             | 29/64      | 29/64   | 13/32  |
|                 | 5/8" x 5/8" x 1/2"       |   | W 04007              | 50       | 500                 | .08             | 17/64      | 17/64   | 25/64  |
|                 | 5/8" x 5/8" x 3/8"       |   | W 04008              | 50       | 500                 | .06             | 17/64      | 17/64   | 11/16  |
|                 | 5/8" x 5/8" x 1/4"       |   | W 04014              | 50       | 500                 | .08             | 17/64      | 17/64   | 11/16  |
|                 | 5/8" x 1/2" x 5/8"       |   | W 04009              | 50       | 500                 | .09             | 21/64      | 5/8     | 21/64  |
|                 | 5/8" x 1/2" x 1/2"       |   | W 04010              | 50       | 500                 | .08             | 17/64      | 9/16    | 25/64  |
|                 | 5/8" x 1/2" x 3/8"       |   | W 04011              | 50       | 500                 | .08             | 17/64      | 39/64   | 11/16  |
|                 | 5/8" x 3/8" x 5/8"       |   | W 04012              | 50       | 500                 | .09             | 21/64      | 11/16   | 21/64  |
|                 | 5/8" x 3/8" x 1/2"       |   | W 40367              | 50       | 500                 | .08             | 17/64      | 39/64   | 25/64  |
|                 | 5/8" x 3/8" x 3/8"       |   | W 04013              | 50       | 500                 | .09             | 17/64      | 39/64   | 11/16  |
|                 | 3/4" x 3/4" x 7/8"       |   | W 04046              | 25       | 250                 | .15             | 33/64      | 33/64   | 31/64  |
|                 | 3/4" x 3/4" x 5/8"       |   | W 04018              | 25       | 250                 | .1              | 21/64      | 21/64   | 7/16   |
|                 | 3/4" x 3/4" x 1/2"       |   | W 04019              | 25       | 250                 | .10             | 21/64      | 21/64   | 53/64  |
|                 | 3/4" x 3/4" x 3/8"       |   | W 04020              | 25       | 250                 | .10             | 21/64      | 21/64   | 13/16  |
|                 | 3/4" x 5/8" x 3/4"       |   | W 04021              | 25       | 225                 | .13             | 13/32      | 3/4     | 25/64  |
|                 | 3/4" x 5/8" x 5/8"       |   | W 04022              | 25       | 250                 | .11             | 19/32      | 1-1/64  | 29/64  |
|                 | 3/4" x 5/8" x 1/2"       |   | W 04023              | 25       | 225                 | .11             | 21/64      | 49/64   | 53/64  |
|                 | 3/4" x 1/2" x 3/4"       |   | W 04025              | 25       | 250                 | .15             | 13/32      | 15/16   | 25/64  |
|                 | 3/4" x 1/2" x 5/8"       |   | W 04026              | 25       | 225                 | .14             | 21/64      | 57/64   | 7/16   |
|                 | 3/4" x 1/2" x 1/2"       |   | W 04027              | 25       | 250                 | .11             | 21/64      | 57/64   | 53/64  |
|                 | 7/8" x 7/8" x 1-1/8"     |   | W 04065              | 10       | 100                 | .22             | 37/64      | 37/64   | 35/64  |
|                 | 7/8" x 7/8" x 3/4"       |   | W 04032              | 25       | 250                 | .17             | 15/32      | 15/32   | 27/32  |
|                 | 7/8" x 7/8" x 5/8"       |   | W 04033              | 25       | 250                 | .14             | 21/64      | 21/64   | 35/64  |
|                 | 7/8" x 7/8" x 1/2"       |   | W 04034              | 25       | 250                 | .11             | 21/64      | 21/64   | 55/64  |
|                 | 7/8" x 7/8" x 3/8"       |   | W 04035              | 25       | 250                 | .11             | 21/64      | 21/64   | 15/16  |
|                 | 7/8" x 3/4" x 7/8"       |   | W 04036              | 25       | 250                 | .19             | 15/32      | 23/32   | 29/64  |
|                 | 7/8" x 3/4" x 3/4"       |   | W 04037              | 25       | 250                 | .17             | 15/32      | 23/32   | 27/32  |
|                 | 7/8" x 5/8" x 7/8"       |   | W 04041              | 25       | 250                 | .18             | 15/32      | 23/32   | 29/64  |
|                 | 7/8" x 5/8" x 3/4"       |   | W 04042              | 25       | 150                 | .17             | 15/32      | 47/64   | 27/32  |
|                 | 7/8" x 5/8" x 5/8"       |   | W 04043              | 25       | 250                 | .15             | 21/64      | 23/32   | 35/64  |
|                 | 7/8" x 5/8" x 1/2"       |   | W 04044              | 25       | 250                 | .12             | 21/64      | 5/8     | 55/64  |
|                 | 7/8" x 5/8" x 3/8"       |   | W 04045              | 25       | 225                 | .15             | 21/64      | 11/16   | 15/16  |
|                 | 7/8" x 1/2" x 7/8"       |   | W 40230              | 25       | 250                 | .19             | 15/32      | 31/32   | 29/64  |
|                 | 7/8" x 1/2" x 5/8"       |   | W 40231              | 25       | 250                 | .17             | 21/64      | 15/16   | 17/32  |
|                 | 7/8" x 1/2" x 1/2"       |   | W 40232              | 25       | 250                 | .12             | 21/64      | 51/64   | 51/64  |
|                 | 1-1/8" x 1-1/8" x 1-5/8" |   | W 40101              | 5        | 50                  | .47             | 1-21/32    | 1-21/32 | 53/64  |
|                 | 1-1/8" x 1-1/8" x 1-3/8" |   | W 04082              | 5        | 50                  | .31             | 11/16      | 11/16   | 37/64  |
|                 | 1-1/8" x 1-1/8" x 7/8"   |   | W 04049              | 10       | 100                 | .32             | 15/32      | 15/32   | 49/64  |
|                 | 1-1/8" x 1-1/8" x 3/4"   |   | W 04050              | 10       | 100                 | .27             | 15/32      | 15/32   | 1-1/64 |
|                 | 1-1/8" x 1-1/8" x 5/8"   |   | W 04051              | 10       | 100                 | .20             | 23/64      | 23/64   | 21/32  |
|                 | 1-1/8" x 1-1/8" x 1/2"   |   | W 04052              | 10       | 100                 | .19             | 23/64      | 23/64   | 1-3/32 |
|                 | 1-1/8" x 7/8" x 1-1/8"   |   | W 04055              | 10       | 100                 | .3              | 19/32      | 1-3/64  | 5/8    |
|                 | 1-1/8" x 7/8" x 7/8"     |   | W 04056              | 10       | 100                 | .25             | 15/32      | 49/64   | 49/64  |



TEE continued

COPPER FITTING

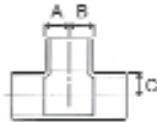

CONNECTION  
C x C x C

MUELLER STYLE  
WT-600

ELKHART STYLE  
111

NIBCO STYLE  
9611

| I               | Size   |                 | Part Number | Box Qty. | Master Qty. | Approx. Net.Wt. | Dimensions |         |         |
|-----------------|--------|-----------------|-------------|----------|-------------|-----------------|------------|---------|---------|
|                 | 2      | 3               |             |          |             |                 | A          | B       | C       |
| <b>REDUCING</b> |        |                 |             |          |             |                 |            |         |         |
|                 | 1-1/8" | 7/8" x 3/4"     | W 04057     | 10       | 90          | .43             | 15/32      | 49/64   | 1-1/64  |
|                 | 1-1/8" | 7/8" x 5/8"     | W 04058     | 10       | 100         | .23             | 23/64      | 41/64   | 21/32   |
|                 | 1-1/8" | 7/8" x 1/2"     | W 04059     | 10       | 100         | .21             | 23/64      | 41/64   | 1-3/32  |
|                 | 1-1/8" | 3/4" x 1-1/8"   | W 40233     | 10       | 100         | .33             | 37/64      | 1-7/32  | 9/16    |
|                 | 1-1/8" | 3/4" x 7/8"     | W 40234     | 10       | 90          | .3              | 15/32      | 1-1/32  | 49/64   |
|                 | 1-1/8" | 3/4" x 3/4"     | W 40235     | 10       | 100         | .31             | 15/32      | 1-1/32  | 1-1/16  |
|                 | 1-1/8" | 3/4" x 5/8"     | W 40236     | 10       | 90          | .35             | 23/64      | 31/32   | 21/32   |
|                 | 1-1/8" | 5/8" x 1-1/8"   | W 04061     | 10       | 100         | .31             | 37/64      | 1-7/32  | 9/16    |
|                 | 1-1/8" | 5/8" x 7/8"     | W 04062     | 10       | 100         | .32             | 15/32      | 1-5/32  | 49/64   |
|                 | 1-1/8" | 5/8" x 5/8"     | W 04063     | 10       | 100         | .36             | 23/64      | 31/32   | 21/32   |
|                 | 1-3/8" | 1-3/8" x 2-1/8" | W 40122     | 2        | 20          | 1.68            | 2-1/16     | 2-1/16  | 1-3/32  |
|                 | 1-3/8" | 1-3/8" x 1-5/2" | W 40100     | 5        | 50          | .72             | 27/32      | 27/32   | 23/32   |
|                 | 1-3/8" | 1-3/8" x 1-1/8" | W 04069     | 5        | 50          | .49             | 37/64      | 37/64   | 53/64   |
|                 | 1-3/8" | 1-3/8" x 7/8"   | W 04070     | 5        | 50          | .33             | 29/64      | 29/64   | 13/16   |
|                 | 1-3/8" | 1-3/8" x 5/8"   | W 04071     | 5        | 50          | .28             | 21/64      | 21/64   | 13/16   |
|                 | 1-3/8" | 1-3/8" x 1/2"   | W 04072     | 5        | 50          | .29             | 21/64      | 21/64   | 1-3/16  |
|                 | 1-3/8" | 1-1/8" x 1-3/8" | W 04073     | 5        | 50          | .54             | 23/32      | 1-7/32  | 49/64   |
|                 | 1-3/8" | 1-1/8" x 1-1/8" | W 04074     | 5        | 50          | .53             | 19/32      | 1-1/8   | 53/64   |
|                 | 1-3/8" | 1-1/8" x 7/8"   | W 04075     | 5        | 50          | .38             | 29/64      | 59/64   | 13/16   |
|                 | 1-3/8" | 1-1/8" x 5/8"   | W 04076     | 5        | 50          | .57             | 21/64      | 51/64   | 13/16   |
|                 | 1-3/8" | 7/8" x 1-3/8"   | W 04078     | 5        | 50          | .56             | 23/32      | 1-9/16  | 25/32   |
|                 | 1-3/8" | 7/8" x 1-1/8"   | W 04079     | 5        | 50          | .52             | 19/32      | 1-27/64 | 1-3/16  |
|                 | 1-3/8" | 7/8" x 7/8"     | W 04080     | 5        | 50          | .39             | 29/64      | 1-7/64  | 1-3/16  |
|                 | 1-3/8" | 7/8" x 5/8"     | W 04081     | 5        | 50          | .32             | 23/64      | 59/64   | 49/64   |
|                 | 1-3/8" | 5/8" x 1-3/8"   | W 04083     | 5        | 50          | .57             | 23/32      | 1-5/8   | 11/16   |
|                 | 1-5/8" | 1-5/8" x 2-1/8" | W 40121     | 2        | 20          | 1.22            | 1-1/16     | 1-1/16  | 57/64   |
|                 | 1-5/8" | 1-5/8" x 1-3/8" | W 04085     | 5        | 50          | .68             | 45/64      | 45/64   | 15/16   |
|                 | 1-5/8" | 1-5/8" x 1-1/8" | W 04086     | 5        | 50          | .48             | 45/64      | 45/64   | 1-19/32 |
|                 | 1-5/8" | 1-5/8" x 7/8"   | W 04087     | 5        | 50          | .43             | 45/64      | 45/64   | 1-53/64 |
|                 | 1-5/8" | 1-5/8" x 5/8"   | W 04088     | 5        | 50          | .42             | 45/64      | 45/64   | 1-57/64 |
|                 | 1-5/8" | 1-5/8" x 1/2"   | W 04089     | 5        | 50          | .41             | 45/64      | 45/64   | 2       |
|                 | 1-5/8" | 1-3/8" x 1-5/8" | W 04090     | 5        | 50          | .68             | 27/32      | 1-3/16  | 53/64   |
|                 | 1-5/8" | 1-3/8" x 1-3/8" | W 04091     | 5        | 50          | .69             | 45/64      | 1-3/16  | 15/16   |
|                 | 1-5/8" | 1-3/8" x 1-1/8" | W 04092     | 5        | 50          | .57             | 45/64      | 1-3/16  | 1-15/32 |
|                 | 1-5/8" | 1-3/8" x 7/8"   | W 04093     | 5        | 50          | .57             | 45/64      | 1-21/64 | 1-5/8   |
|                 | 1-5/8" | 1-3/8" x 5/8"   | W 04094     | 5        | 50          | .45             | 45/64      | 1-21/64 | 1-49/64 |
|                 | 1-5/8" | 1-1/8" x 1-5/8" | W 04095     | 5        | 50          | .68             | 53/64      | 1-23/32 | 53/64   |
|                 | 1-5/8" | 1-1/8" x 1-3/8" | W 04096     | 5        | 50          | .65             | 23/32      | 1-29/64 | 15/16   |
|                 | 1-5/8" | 1-1/8" x 1-1/8" | W 04097     | 5        | 50          | .61             | 23/32      | 1-29/64 | 1-19/32 |
|                 | 1-5/8" | 1-1/8" x 7/8"   | W 04098     | 5        | 50          | .56             | 23/32      | 1-29/64 | 1-53/64 |
|                 | 1-5/8" | 1-1/8" x 5/8"   | W 40237     | 5        | 30          | .45             | 23/32      | 1-11/16 | 1-61/64 |
|                 | 1-5/8" | 7/8" x 1-5/8"   | W 04099     | 5        | 50          | .67             | 27/32      | 2-1/8   | 53/64   |
|                 | 1-5/8" | 7/8" x 1-3/8"   | W 40239     | 5        | 50          | .75             | 23/32      | 1-11/16 | 15/16   |
|                 | 1-5/8" | 7/8" x 1-1/8"   | W 40240     | 5        | 50          | .52             | 23/32      | 1-11/16 | 1-19/32 |
|                 | 1-5/8" | 7/8" x 7/8"     | W 40238     | 5        | 50          | .55             | 23/32      | 1-11/16 | 1-53/64 |
|                 | 1-5/8" | 7/8" x 5/8"     | W 40243     | 5        | 50          | .47             | 23/32      | 1-29/64 | 1-61/64 |
|                 | 1-5/8" | 5/8" x 1-5/8"   | W 40244     | 5        | 50          | .66             | 27/32      | 2-1/4   | 53/64   |
|                 | 2-1/8" | 2-1/8" x 3-1/8" | W 40153     | 1        | 10          | 2.55            | 1-13/16    | 1-13/16 | 1-3/32  |
|                 | 2-1/8" | 2-1/8" x 2-5/8" | W 40144     | 1        | 10          | 1.46            | 1-11/32    | 1-11/32 | 1-3/32  |
|                 | 2-1/8" | 2-1/8" x 1-5/8" | W 40103     | 5        | 50          | 1.19            | 27/32      | 27/32   | 1-13/64 |
|                 | 2-1/8" | 2-1/8" x 1-3/8" | W 40104     | 5        | 50          | .85             | 27/32      | 27/32   | 1-27/32 |
|                 | 2-1/8" | 2-1/8" x 1-1/8" | W 40105     | 5        | 50          | .88             | 37/64      | 37/64   | 1-9/32  |
|                 | 2-1/8" | 2-1/8" x 7/8"   | W 40106     | 5        | 50          | .83             | 37/64      | 37/64   | 1-11/16 |
|                 | 2-1/8" | 2-1/8" x 5/8"   | W 40107     | 5        | 50          | .67             | 37/64      | 37/64   | 1-15/16 |



TUBE & PIPE

METAL FITTINGS & NIPPLES

PLASTIC FITTINGS

VALVES

FILTER-DRIERS & STRAINERS

**TEE continued**

**COPPER FITTING**

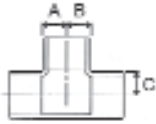

CONNECTION  
**C x C x C**

| I               | MUELLER STYLE<br>WT-600  |             | ELKHART STYLE<br>111 |             | NIBCO STYLE<br>9611 |         | Dimensions |         |  |
|-----------------|--------------------------|-------------|----------------------|-------------|---------------------|---------|------------|---------|--|
|                 | Size                     | Part Number | Box Qty.             | Master Qty. | Approx. Net.Wt.     | A       | B          | C       |  |
| <b>REDUCING</b> |                          |             |                      |             |                     |         |            |         |  |
|                 | 1-1/8" x 7/8" x 1/2"     | W 40108     | 2                    | 20          | .68                 | 37/64   | 37/64      | 2-1/64  |  |
|                 | 1-1/8" x 1-5/8" x 2-1/8" | W 40109     | 2                    | 20          | 1.60                | 1-3/32  | 1-63/64    | 1-3/32  |  |
|                 | 1-1/8" x 1-5/8" x 1-5/8" | W 40110     | 2                    | 20          | 1.15                | 27/32   | 1-23/32    | 1-7/32  |  |
|                 | 1-1/8" x 1-5/8" x 1-3/8" | W 40111     | 2                    | 20          | .86                 | 27/32   | 1-23/32    | 1-27/32 |  |
|                 | 1-1/8" x 1-5/8" x 1-1/8" | W 40112     | 2                    | 20          | 1.06                | 37/64   | 1-29/64    | 1-19/64 |  |
|                 | 1-1/8" x 1-5/8" x 7/8"   | W 40113     | 2                    | 20          | .75                 | 37/64   | 1-29/64    | 1-11/16 |  |
|                 | 1-1/8" x 1-5/8" x 5/8"   | W 40114     | 5                    | 50          | .77                 | 37/64   | 1-9/16     | 1-15/16 |  |
|                 | 1-1/8" x 1-3/8" x 2-1/8" | "W 40115    | 2                    | 20          | 1.3                 | 1-7/64  | 2-3/64     | 1-7/64  |  |
|                 | 1-1/8" x 1-3/8" x 1-5/8" | "W 40116    | 2                    | 20          | 1.14                | 27/32   | 1-27/32    | 1-7/32  |  |
|                 | 1-1/8" x 1-3/8" x 1-3/8" | "W 40117    | 2                    | 20          | 1.09                | 27/32   | 1-27/32    | 1-27/32 |  |
|                 | 1-1/8" x 1-3/8" x 1-1/8" | "W 40118    | 2                    | 20          | .95                 | 19/32   | 1-37/64    | 1-5/16  |  |
|                 | 1-1/8" x 1-3/8" x 7/8"   | W 40119     | 5                    | 50          | .76                 | 37/64   | 1-19/32    | 1-11/16 |  |
|                 | 1-1/8" x 1-3/8" x 5/8"   | W 40120     | 5                    | 20          | .78                 | 37/64   | 1-19/32    | 1-15/16 |  |
|                 | 1-1/8" x 1-1/8" x 2-1/8" | W 40245     | 5                    | 25          | 1.64                | 19/32   | 2-61/64    | 1-9/32  |  |
|                 | 1-1/8" x 1-1/8" x 1-1/8" | W 40247     | 5                    | 50          | 1.06                | 1-3/32  | 2-17/32    | 1-1/8   |  |
|                 | 1-1/8" x 7/8" x 2-1/8"   | W 40248     | 5                    | 25          | 1.71                | 1-3/32  | 2-11/16    | 1-1/8   |  |
|                 | 1-1/8" x 5/8" x 2-1/8"   | W 40249     | 5                    | 25          | 1.66                | 1-3/32  | 2-23/32    | 1-1/8   |  |
|                 | 2-5/8" x 2-5/8" x 2-1/8" | W 40124     | 2                    | 20          | 1.59                | 1-3/32  | 1-3/32     | 1-17/32 |  |
|                 | 2-5/8" x 2-5/8" x 1-5/8" | W 40125     | 2                    | 20          | 1.49                | 1-3/32  | 1-3/32     | 2-5/16  |  |
|                 | 2-5/8" x 2-5/8" x 1-3/8" | W 40126     | 2                    | 20          | 1.87                | 1-3/32  | 1-3/32     | 2-1/2   |  |
|                 | 2-5/8" x 2-5/8" x 1-1/8" | W 40127     | 2                    | 20          | 1.83                | 1-3/32  | 1-3/32     | 2-25/32 |  |
|                 | 2-5/8" x 2-5/8" x 7/8"   | W 40128     | 1                    | 10          | 1.83                | 1-3/32  | 1-3/32     | 2-55/64 |  |
|                 | 2-5/8" x 2-5/8" x 5/8"   | W 40129     | 1                    | 10          | 2.05                | 1-3/32  | 1-3/32     | 3       |  |
|                 | 2-5/8" x 2-1/8" x 2-5/8" | W 40130     | 4                    | 20          | 2.3                 | 1-5/16  | 2-7/16     | 1-3/8   |  |
|                 | 2-5/8" x 2-1/8" x 2-1/8" | W 40131     | 2                    | 20          | 1.84                | 1-5/64  | 2-11/64    | 1-1/2   |  |
|                 | 2-5/8" x 2-1/8" x 1-5/8" | W 40132     | 4                    | 20          | 2.09                | 1-5/64  | 2-11/64    | 2-7/16  |  |
|                 | 2-5/8" x 2-1/8" x 1-3/8" | W 40133     | 4                    | 20          | 2.12                | 1-5/64  | 2-11/64    | 2-5/8   |  |
|                 | 2-5/8" x 2-1/8" x 1-1/8" | W 40134     | 4                    | 20          | 2.1                 | 1-5/64  | 2-11/64    | 2-51/64 |  |
|                 | 2-5/8" x 2-1/8" x 7/8"   | W 40135     | 4                    | 20          | 2.06                | 1-5/64  | 2-11/64    | 3-1/32  |  |
|                 | 2-5/8" x 2-1/8" x 5/8"   | W 40136     | 4                    | 20          | 2.2                 | 1-5/64  | 2-11/64    | 3-3/16  |  |
|                 | 2-5/8" x 1-5/8" x 2-5/8" | W 40137     | 4                    | 20          | 2.32                | 1-5/16  | 2-49/64    | 1-3/8   |  |
|                 | 2-5/8" x 1-5/8" x 2-1/8" | W 40138     | 4                    | 20          | 1.84                | 1-3/32  | 2-27/64    | 1-1/2   |  |
|                 | 2-5/8" x 1-5/8" x 1-5/8" | W 40139     | 4                    | 20          | 2.11                | 1-3/32  | 2-27/64    | 2-7/16  |  |
|                 | 2-5/8" x 1-5/8" x 1-3/8" | W 40140     | 4                    | 20          | 2.17                | 1-3/32  | 2-27/64    | 2-9/16  |  |
|                 | 2-5/8" x 1-5/8" x 1-1/8" | W 40141     | 4                    | 20          | 1.83                | 1-3/32  | 2-27/64    | 2-51/64 |  |
|                 | 2-5/8" x 1-5/8" x 7/8"   | W 40142     | 4                    | 20          | 2.36                | 1-3/32  | 2-27/64    | 2-29/32 |  |
|                 | 2-5/8" x 1-5/8" x 5/8"   | W 40143     | 4                    | 20          | 2.36                | 1-3/32  | 2-27/64    | 3-1/64  |  |
|                 | 2-5/8" x 1-3/8" x 2-5/8" | W 40220     | 4                    | 20          | 2.35                | 1-5/16  | 2-7/8      | 1-3/8   |  |
|                 | 2-5/8" x 1-3/8" x 2-1/8" | W 40250     | 4                    | 20          | 1.82                | 1-3/32  | 2-35/64    | 1-1/2   |  |
|                 | 2-5/8" x 1-3/8" x 1-5/8" | W 40251     | 4                    | 20          | 2.47                | 1-3/32  | 2-35/64    | 2-7/16  |  |
|                 | 2-5/8" x 1-3/8" x 1-3/8" | W 40252     | 4                    | 20          | 1.96                | 1-3/32  | 2-35/64    | 2-5/8   |  |
|                 | 2-5/8" x 1-3/8" x 1-1/8" | W 40253     | 4                    | 20          | 2.47                | 1-3/32  | 2-35/64    | 2-3/4   |  |
|                 | 2-5/8" x 1-3/8" x 7/8"   | W 40254     | 4                    | 20          | 2.18                | 1-3/32  | 2-35/64    | 2-27/32 |  |
|                 | 2-5/8" x 1-3/8" x 5/8"   | W 40255     | 4                    | 20          | 2.47                | 1-3/32  | 2-35/64    | 2-31/32 |  |
|                 | 2-5/8" x 1-1/8" x 2-5/8" | W 40221     | 4                    | 20          | 2.39                | 1-5/16  | 3          | 1-29/64 |  |
|                 | 2-5/8" x 1-1/8" x 2-1/8" | W 40256     | 4                    | 20          | 1.97                | 1-5/64  | 2-23/32    | 1-1/2   |  |
|                 | 2-5/8" x 1-1/8" x 1-5/8" | W 40257     | 4                    | 20          | 2.15                | 1-3/32  | 2-23/32    | 2-7/16  |  |
|                 | 2-5/8" x 1-1/8" x 1-3/8" | W 40258     | 4                    | 20          | 2.04                | 1-3/32  | 2-11/16    | 2-1/2   |  |
|                 | 2-5/8" x 1-1/8" x 1-1/8" | W 40259     | 4                    | 20          | 2.27                | 1-5/64  | 2-23/32    | 2-3/4   |  |
|                 | 2-5/8" x 7/8" x 2-5/8"   | W 40222     | 4                    | 20          | 2.41                | 1-5/16  | 3-5/16     | 1-3/8   |  |
|                 | 3-1/8" x 3-1/8" x 2-5/8" | W 40151     | 2                    | 10          | 2.45                | 1-19/32 | 1-19/32    | 2-31/32 |  |
|                 | 3-1/8" x 3-1/8" x 2-1/8" | W 40150     | 2                    | 20          | 2.3                 | 1-5/64  | 1-5/64     | 1-25/32 |  |
|                 | 3-1/8" x 3-1/8" x 1-5/8" | W 40149     | 2                    | 10          | 2.18                | 1-5/64  | 1-5/64     | 2-3/4   |  |
|                 | 3-1/8" x 3-1/8" x 1-3/8" | W 40148     | 2                    | 10          | 2.38                | 1-5/64  | 1-5/64     | 3       |  |

TUBE & PIPE

METAL FITTINGS & NIPPLES

PLASTIC FITTINGS

VALVES

FILTER-DRIERS & STRAINERS



TEE continued

COPPER FITTING

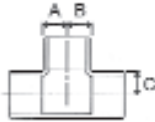

CONNECTION  
C x C x C

MUELLER STYLE  
WT-600

ELKHART STYLE  
111

NIBCO STYLE  
9611

| I               | Size   |                 | Part Number | Box Qty. | Master Qty. | Approx. Net.Wt. | Dimensions |         |         |
|-----------------|--------|-----------------|-------------|----------|-------------|-----------------|------------|---------|---------|
|                 | 2      | 3               |             |          |             |                 | A          | B       | C       |
| <b>REDUCING</b> |        |                 |             |          |             |                 |            |         |         |
|                 | 3-1/8" | 3-1/8" x 1-1/8" | W 40147     | 2        | 20          | 1.96            | 23/32      | 23/32   | 1-55/64 |
|                 | 3-1/8" | 3-1/8" x 7/8"   | W 40146     | 2        | 20          | 1.49            | 23/32      | 23/32   | 2-11/32 |
|                 | 3-1/8" | 3-1/8" x 5/8"   | W 40145     | 2        | 20          | 1.38            | 23/32      | 23/32   | 2-17/32 |
|                 | 3-1/8" | 2-5/8" x 3-1/8" | W 40159     | 2        | 10          | 2.96            | 1-19/32    | 2-3/4   | 1-5/8   |
|                 | 3-1/8" | 2-5/8" x 2-5/8" | W 40158     | 2        | 10          | 4.52            | 1-19/32    | 2-13/16 | 2-27/32 |
|                 | 3-1/8" | 2-5/8" x 2-1/8" | W 40157     | 2        | 10          | 2.68            | 1-5/64     | 2-5/32  | 1-25/32 |
|                 | 3-1/8" | 2-5/8" x 1-5/8" | W 40156     | 2        | 10          | 2.63            | 1-5/64     | 2-5/32  | 2-11/16 |
|                 | 3-1/8" | 2-5/8" x 1-3/8" | W 40155     | 2        | 10          | 2.62            | 1-5/64     | 2-5/32  | 2-51/64 |
|                 | 3-1/8" | 2-5/8" x 1-1/8" | W 40154     | 2        | 20          | 2.02            | 23/32      | 1-11/16 | 2       |
|                 | 3-1/8" | 2-1/8" x 3-1/8" | W 40167     | 2        | 10          | 3.07            | 1-19/32    | 3-1/16  | 1-41/64 |
|                 | 3-1/8" | 2-5/8" x 2-5/8" | W 40165     | 2        | 10          | 4.64            | 1-19/32    | 3-3/16  | 2-27/32 |
|                 | 3-1/8" | 2-5/8" x 2-1/8" | W 40164     | 2        | 10          | 2.75            | 1-5/64     | 2-17/32 | 1-25/32 |
|                 | 3-1/8" | 2-5/8" x 1-5/8" | W 40163     | 2        | 10          | 2.57            | 1-5/64     | 2-19/32 | 2-3/4   |
|                 | 3-1/8" | 2-5/8" x 1-3/8" | W 40162     | 2        | 10          | 2.61            | 1-5/64     | 2-17/64 | 2-7/8   |
|                 | 3-1/8" | 2-5/8" x 1-1/8" | W 40161     | 2        | 20          | 2.04            | 23/32      | 2-1/8   | 2       |
|                 | 3-1/8" | 1-5/8" x 3-1/8" | W 40174     | 2        | 10          | 2.97            | 1-21/32    | 3-7/16  | 1-5/8   |
|                 | 3-1/8" | 1-3/8" x 3-1/8" | W 40181     | 2        | 10          | 3.14            | 1-19/32    | 3-7/16  | 1-5/8   |
|                 | 3-1/8" | 1-1/8" x 3-1/8" | W 40178     | 2        | 10          | 3.02            | 1-19/32    | 3-1/2   | 1-41/64 |
|                 | 3-1/8" | 7/8" x 3-1/8"   | "W 40179    | 2        | 10          | 3.03            | 1-19/32    | 3-21/32 | 1-5/8   |
|                 | 4-1/8" | 4-1/8" x 3-1/8" | W 40198     | 1        | 5           | 4.94            | 1-19/32    | 1-19/32 | 2-41/64 |
|                 | 4-1/8" | 4-1/8" x 2-5/8" | W 40197     | 1        | 5           | 5.16            | 1-19/32    | 1-19/32 | 3-13/64 |
|                 | 4-1/8" | 4-1/8" x 2-1/8" | "W 40196    | 1        | 10          | 4.52            | 1-1/16     | 1-1/16  | 2-23/64 |
|                 | 4-1/8" | 4-1/8" x 1-5/8" | W 40195     | 1        | 10          | 4.47            | 1-1/16     | 1-1/16  | 3-7/32  |
|                 | 4-1/8" | 4-1/8" x 1-3/8" | W 40194     | 1        | 10          | 4.55            | 1-1/16     | 1-1/16  | 3-5/8   |
|                 | 4-1/8" | 4-1/8" x 1-1/8" | "W 40193    | 1        | 10          | 3.05            | 37/64      | 37/64   | 2-37/64 |
|                 | 4-1/8" | 4-1/8" x 7/8"   | W 40192     | 1        | 10          | 2.89            | 9/16       | 9/16    | 3-1/16  |
|                 | 4-1/8" | 4-1/8" x 5/8"   | W 40191     | 1        | 10          | 2.89            | 9/16       | 9/16    | 2-63/64 |
|                 | 4-1/8" | 3-1/8" x 4-1/8" | W 40208     | 1        | 5           | 8.66            | 2-1/8      | 3-3/4   | 2-13/64 |
|                 | 4-1/8" | 3-1/8" x 3-1/8" | W 40206     | 1        | 5           | 5.12            | 1-19/32    | 3-1/8   | 2-41/64 |
|                 | 4-1/8" | 3-1/8" x 2-5/8" | W 40205     | 1        | 5           | 5.61            | 1-19/32    | 3-1/8   | 2-13/64 |
|                 | 4-1/8" | 3-1/8" x 2-1/8" | "W 40204    | 1        | 5           | 4.76            | 1-1/16     | 2-5/8   | 2-15/32 |
|                 | 4-1/8" | 2-5/8" x 4-1/8" | W 40212     | 1        | 5           | 7.79            | 2-1/8      | 3-15/16 | 2-13/64 |
|                 | 4-1/8" | 2-1/8" x 4-1/8" | W 40216     | 1        | 5           | 8.95            | 2-1/8      | 2-11/64 | 2-13/64 |
|                 | 4-1/8" | 1-5/8" x 4-1/8" | "W 40215    | 1        | 5           | 8.51            | 2-1/8      | 4-27/64 | 2-13/64 |
|                 | 4-1/8" | 1-3/8" x 4-1/8" | W 40214     | 1        | 5           | 8.57            | 2-1/8      | 4-35/64 | 2-3/16  |
|                 | 4-1/8" | 1-1/8" x 4-1/8" | W 40213     | 1        | 5           | 9.33            | 2-1/8      | 4-43/64 | 2-13/64 |
|                 | 6-1/8" | 6-1/8" x 3-1/8" | W 40503     | -        | 1           | 11              | 1-3/4      | 1-3/4   | 3-47/64 |
|                 | 6-1/8" | 6-1/8" x 2-5/8" | W 40504     | -        | 1           | 11.1            | 1-3/4      | 1-3/4   | 4-51/64 |
|                 | 6-1/8" | 6-1/8" x 2-1/8" | W 40505     | -        | 1           | 9.54            | 1-3/4      | 1-3/4   | 4-59/64 |

TUBE & PIPE

METAL FITTINGS & NIPPLES

PLASTIC FITTINGS

VALVES

FILTER-DRIERS & STRAINERS



**TEE • FORGED BRASS**

**COPPER FITTING**

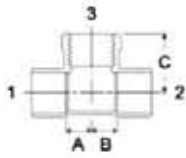
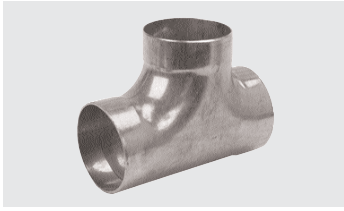

CONNECTION  
**C x C x F**

MUELLER STYLE  
WT-602

ELKHART STYLE  
N/A

NIBCO STYLE  
N/A

| I | Size               | 3 | Part Number | Box Qty. | Master Qty. | Approx. Net.Wt. | Dimensions |        |   |
|---|--------------------|---|-------------|----------|-------------|-----------------|------------|--------|---|
|   | 2                  |   |             |          |             |                 | A          | B      | C |
|   | 1/4" x 1/4" x 1/4" |   | W 04208*    | 50       | 450         | .09             | 7/16       | 9/16   |   |
|   | 1/4" x 1/4" x 1/8" |   | W 04209*    | 50       | 1,200       | .04             | 1/4        | 27/64  |   |
|   | 3/8" x 3/8" x 3/8" |   | W 04228*    | 25       | 350         | .15             | 9/16       | 21/32  |   |
|   | 3/8" x 3/8" x 1/4" |   | W 04229*    | 25       | 400         | .10             | 7/16       | 5/8    |   |
|   | 3/8" x 3/8" x 1/8" |   | W 04230*    | 10       | 400         | .11             | 7/16       | 9/16   |   |
|   | 1/2" x 1/2" x 3/8" |   | W 04259*    | 10       | 240         | .15             | 1/16       | 23/32  |   |
|   | 5/8" x 5/8" x 1/2" |   | W 04283*    | 10       | 150         | .33             | 47/16      | 1-3/32 |   |

**TEE • FITTING**

**COPPER FITTING**

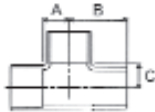

CONNECTION  
**C x FTG x C**

MUELLER STYLE  
WT-600F

ELKHART STYLE  
111-2

NIBCO STYLE  
9611-2

| I | Size | 3 | Part Number | Box Qty. | Master Qty. | Approx. Net.Wt. | Dimensions |         |       |
|---|------|---|-------------|----------|-------------|-----------------|------------|---------|-------|
|   | 2    |   |             |          |             |                 | A          | B       | C     |
|   | 5/8" |   | W 04106     | 50       | 300         | .1              | 21/64      | 1-19/64 | 21/64 |
|   | 7/8" |   | W 04131     | 25       | 150         | .19             | 15/32      | 1-25/32 | 29/64 |

**UNION**

**COPPER FITTING**

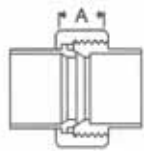
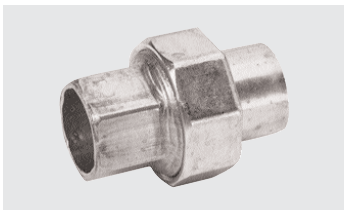

CONNECTION  
**C x C**

MUELLER STYLE  
WC-407

ELKHART STYLE  
4733

NIBCO STYLE  
9633

| I | Size   | 3 | Part Number | Box Qty. | Master Qty. | Approx. Net.Wt. | Dimensions |   |   |
|---|--------|---|-------------|----------|-------------|-----------------|------------|---|---|
|   | 2      |   |             |          |             |                 | A          | B | C |
|   | 3/8"   |   | W 08001     | 25       | 250         | .12             | 19/32      |   |   |
|   | 1/2"   |   | W 08002     | 25       | 250         | .11             | 7/16       |   |   |
|   | 5/8"   |   | W 08003     | 25       | 250         | .16             | 15/32      |   |   |
|   | 7/8"   |   | W 08004     | 25       | 150         | .37             | 5/8        |   |   |
|   | 1-1/8" |   | W 08005     | 10       | 100         | .52             | 29/64      |   |   |
|   | 1-3/8" |   | A 11205*    | -        | 25          | .75             | 1/2        |   |   |
|   | 1-5/8" |   | A 11206*    | -        | 25          | 1.04            | 23/32      |   |   |
|   | 2-1/8" |   | A 11207*    | -        | 25          | 1.77            | 1/2        |   |   |
|   | 2-5/8" |   | A 11216*    | -        | 20          | 3.25            | 1          |   |   |
|   | 3-1/8" |   | A 11217*    | -        | 15          | 4.75            | 1-5/32     |   |   |

**HANGER • HI EAR**

**COPPER FITTING**



CONNECTION  
**C**

MUELLER STYLE  
W-124

ELKHART STYLE  
124

NIBCO STYLE  
N/A

| I | Size   | 3 | Part Number | Box Qty. | Master Qty. | Approx. Net.Wt. | Dimensions |       |   |
|---|--------|---|-------------|----------|-------------|-----------------|------------|-------|---|
|   | 2      |   |             |          |             |                 | A          | B     | C |
|   | 5/8"   |   | A 03167*    | 100      | 1,000       | .03             | 1-5/8      | 47/64 |   |
|   | 7/8"   |   | A 03168*    | 25       | 500         | .04             | 1-5/8      | 7/8   |   |
|   | 1-1/8" |   | A 03171*    | 25       | 250         | .04             | 1-1/8      | 1     |   |

**COPPER TUBE STRAP • TWO-HOLE**

**COPPER FITTING**



CONNECTION

MUELLER STYLE  
WS-1100

ELKHART STYLE  
120

NIBCO STYLE  
9624

| I | Size   | 3 | Part Number | Box Qty. | Master Qty. | Approx. Net.Wt. | Dimensions |   |   |
|---|--------|---|-------------|----------|-------------|-----------------|------------|---|---|
|   | 2      |   |             |          |             |                 | A          | B | C |
|   | 1/4"   |   | A 01203     | 100      | 4,000       | .01             |            |   |   |
|   | 3/8"   |   | A 01278     | 100      | 5,600       | .01             |            |   |   |
|   | 1/2"   |   | A 01366     | 100      | 3,400       | .01             |            |   |   |
|   | 5/8"   |   | A 02529     | 100      | 1,500       | .01             |            |   |   |
|   | 3/4"   |   | A 01467     | 100      | 2,000       | .01             |            |   |   |
|   | 7/8"   |   | A 02574     | 50       | 750         | .01             |            |   |   |
|   | 1-1/8" |   | A 02614     | 50       | 750         | .02             |            |   |   |
|   | 1-3/8" |   | A 02650     | 50       | 500         | .04             |            |   |   |
|   | 1-5/8" |   | A 02675     | 50       | 500         | .05             |            |   |   |
|   | 2-1/8" |   | A 02708     | 50       | 500         | .06             |            |   |   |

**COPPER TUBE STRAP • PERFORATED**

**COPPER FITTING**

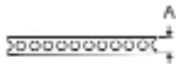

CONNECTION

MUELLER STYLE  
WS-1101

ELKHART STYLE  
125

NIBCO STYLE  
9623

| I | Size        | 3 | Part Number | Box Qty. | Master Qty. | Approx. Net.Wt. | Dimensions |   |   |
|---|-------------|---|-------------|----------|-------------|-----------------|------------|---|---|
|   | 2           |   |             |          |             |                 | A          | B | C |
|   | 25 Ft. Roll |   | A 01211*    | 1        | 10          | 1.63            | .75        |   |   |

TUBE & PIPE

METAL FITTINGS & NIPPLES

PLASTIC FITTINGS

VALVES

FILTER-DRYERS & STRAINERS



# Iron Fittings & Steel Nipples



Mueller boasts an extensive line of black and galvanized malleable iron fittings and steel nipples. Galvanized items are coated for water applications and meet low lead requirements. Fittings are offered from 1/8" – 6" in diameter. Each fitting has the Mueller brand cast into the body, a sign of assured 100% quality inspection and testing.



- Malleable iron fittings meet material: ANSI/ASTM A-197; dimensions: ANSI/ASME B.16.3, B-16.14, B16-39 and Threads: ANSI B1.20.1
- Steel nipples/Pre-Cut Pipe meet material: ANSI/ASTM A.733.A5320; Threads: ANSI B1.20.1
- NAFTA approved Steel Nipples

## 45° ELBOW

## MALLEABLE IRON



| Galvanized Part No. | Black Part No. | Size   | Inner/Master Carton Qty. | Master Weight (lbs.) |
|---------------------|----------------|--------|--------------------------|----------------------|
| 510-200             | 520-200        | 1/8"   | 50/600                   | 45                   |
| 510-201             | 520-201        | 1/4"   | 35/420                   | 46                   |
| 510-202             | 520-202        | 3/8"   | 50/300                   | 47                   |
| 510-203             | 520-203        | 1/2"   | 50/200                   | 45                   |
| 510-204             | 520-204        | 3/4"   | 40/120                   | 42                   |
| 510-205             | 520-205        | 1"     | 20/60                    | 35                   |
| 510-206             | 520-206        | 1-1/4" | 20/80                    | 68                   |
| 510-207             | 520-207        | 1-1/2" | 15/60                    | 67                   |
| 510-208             | 520-208        | 2"     | 9/36                     | 65                   |
| 510-209             | 520-209        | 2-1/2" | 12/24                    | 69                   |
| 510-210             | 520-210        | 3"     | 5/15                     | 68                   |
| 510-211             | 520-211        | 4"     | 3/6                      | 45                   |
| 510-213             | 520-213        | 6"     | NA/2                     | 36                   |

**45° ELBOW • STREET**

**MALLEABLE IRON**



| Galvanized Part No. | Black Part No. | Size   | Inner/Master Carton Qty. | Master Weight (lbs.) |
|---------------------|----------------|--------|--------------------------|----------------------|
| 510-500             | 520-500        | 1/8"   | 50/1200                  | 68                   |
| 510-501             | 520-501        | 1/4"   | 35/420                   | 36                   |
| 510-502             | 520-502        | 3/8"   | 50/300                   | 35                   |
| 510-503             | 520-503        | 1/2"   | 40/240                   | 44                   |
| 510-504             | 520-504        | 3/4"   | 60/120                   | 39                   |
| 510-505             | 520-505        | 1"     | 25/75                    | 40                   |
| 510-506             | 520-506        | 1-1/4" | 20/80                    | 58                   |
| 510-507             | 520-507        | 1-1/2" | 15/60                    | 60                   |
| 510-508             | 520-508        | 2"     | 9/36                     | 58                   |
| 510-509             | 520-509        | 2-1/2" | NA/13                    | 37                   |
| 510-510             | 520-510        | 3"     | 3/9                      | 39                   |
| 510-511             | 520-511        | 4"     | NA/7                     | 50                   |

**90° ELBOW**

**MALLEABLE IRON**



| Galvanized Part No. | Black Part No. | Size   | Inner/Master Carton Qty. | Master Weight (lbs.) |
|---------------------|----------------|--------|--------------------------|----------------------|
| 510-000             | 520-000        | 1/8"   | 50/600                   | 42                   |
| 510-001             | 520-001        | 1/4"   | 35/420                   | 46                   |
| 510-002             | 520-002        | 3/8"   | 45/270                   | 46                   |
| 510-003             | 520-003        | 1/2"   | 50/200                   | 51                   |
| 510-004             | 520-004        | 3/4"   | 35/105                   | 43                   |
| 510-005             | 520-005        | 1"     | 20/60                    | 40                   |
| 510-006             | 520-006        | 1-1/4" | 20/40                    | 38                   |
| 510-007             | 520-007        | 1-1/2" | 15/30                    | 39                   |
| 510-008             | 520-008        | 2"     | 8/32                     | 64                   |
| 510-009             | 520-009        | 2-1/2" | NA/13                    | 46                   |
| 510-010             | 520-010        | 3"     | NA/7                     | 39                   |
| 510-011             | 520-011        | 4"     | 2/6                      | 56                   |
| 510-013             | 520-013        | 6"     | NA/2                     | 42                   |

**90° ELBOW • STREET**

**MALLEABLE IRON**



| Galvanized Part No. | Black Part No. | Size   | Inner/Master Carton Qty. | Master Weight (lbs.) |
|---------------------|----------------|--------|--------------------------|----------------------|
| 510-300             | 520-300        | 1/8"   | 50/600                   | 35                   |
| 510-301             | 520-301        | 1/4"   | 35/420                   | 40                   |
| 510-302             | 520-302        | 3/8"   | 40/240                   | 37                   |
| 510-302             | 520-302        | 3/8"   | 40/240                   | 37                   |
| 510-303             | 520-303        | 1/2"   | 60/180                   | 44                   |
| 510-304             | 520-304        | 3/4"   | 35/105                   | 40                   |
| 510-305             | 520-305        | 1"     | 30/60                    | 37                   |
| 510-306             | 520-306        | 1-1/4" | 18/72                    | 65                   |
| 510-307             | 520-307        | 1-1/2" | 18/54                    | 68                   |
| 510-308             | 520-308        | 2"     | 10/30                    | 55                   |
| 510-309             | 520-309        | 2-1/2" | 6/18                     | 61                   |
| 510-310             | 520-310        | 3"     | NA/7                     | 39                   |
| 510-311             | 520-311        | 4"     | 2/6                      | 59                   |



## EXTENSION PIECE

## MALLEABLE IRON



| Galvanized Part No. | Black Part No. | Size | Inner/Master Carton Qty. | Master Weight (lbs.) |
|---------------------|----------------|------|--------------------------|----------------------|
| 511-613             | —              | 1/2" | 50/300                   | 48                   |
| 511-614             | —              | 3/4" | 60/180                   | 47                   |

## ELBOW • REDUCING

## MALLEABLE IRON



| Galvanized Part No. | Black Part No. | Size            | Inner/Master Carton Qty. | Master Weight (lbs.) |
|---------------------|----------------|-----------------|--------------------------|----------------------|
| 510-120             | 520-120        | 3/8" x 1/8"     | 60/360                   | 45                   |
| 510-121             | 520-121        | 3/8" x 1/4"     | 60/360                   | 53                   |
| 510-110             | 520-110        | 1/4" x 1/8"     | 60/360                   | 35                   |
| 510-130             | 520-130        | 1/2" x 1/8"     | 40/480                   | 69                   |
| 510-131             | 520-131        | 1/2" x 1/4"     | 40/240                   | 47                   |
| 510-132             | 520-132        | 1/2" x 3/8"     | 50/200                   | 43                   |
| 510-141             | 520-141        | 3/4" x 1/4"     | 50/150                   | 38                   |
| 510-142             | 520-142        | 3/4" x 3/8"     | 50/150                   | 44                   |
| 510-143             | 520-143        | 3/4" x 1/2"     | 40/120                   | 42                   |
| 510-144             | 520-144        | 1" x 1/2"       | 30/90                    | 43                   |
| 510-151             | 520-151        | 1" x 1/4"       | 25/150                   | 56                   |
| 510-152             | 520-152        | 1" x 3/8"       | 25/150                   | 62                   |
| 510-154             | 520-154        | 1" x 3/4"       | 25/75                    | 41                   |
| 510-163             | 520-163        | 1-1/4" x 1/2"   | 35/70                    | 37                   |
| 510-164             | 520-164        | 1-1/4" x 3/4"   | 30/60                    | 41                   |
| 510-165             | 520-165        | 1-1/4" x 1"     | 20/40                    | 35                   |
| 510-157             | 520-157        | 1-1/2" x 1"     | 20/40                    | 41                   |
| 510-173             | 520-173        | 1-1/2" x 1/2"   | 25/50                    | 36                   |
| 510-174             | 520-174        | 1-1/2" x 3/4"   | 15/45                    | 40                   |
| 510-176             | 520-176        | 1-1/2" x 1-1/4" | 15/60                    | 69                   |
| 510-183             | 520-183        | 2" x 1/2"       | 15/60                    | 105                  |
| 510-184             | 520-184        | 2" x 3/4"       | 15/30                    | 39                   |
| 510-185             | 520-185        | 2" x 1"         | 14/28                    | 38                   |
| 510-186             | 520-186        | 2" x 1-1/4"     | 10/40                    | 61                   |
| 510-187             | 520-187        | 2" x 1-1/2"     | 10/40                    | 66                   |
| 510-194             | 520-194        | 2-1/2" x 3/4"   | 15/30                    | 66                   |
| 510-195             | 520-195        | 2-1/2" x 1"     | 15/30                    | 68                   |
| 510-196             | 520-196        | 2-1/2" x 1-1/4" | NA/15                    | 36                   |
| 510-197             | 520-197        | 2-1/2" x 1-1/2" | NA/15                    | 39                   |
| 510-198             | 520-198        | 2-1/2" x 2"     | 5/15                     | 43                   |
| 510-115             | 520-115        | 3" x 1"         | 10/20                    | 59                   |
| 510-116             | 520-116        | 3" x 1-1/4"     | 10/20                    | 60                   |
| 510-117             | 520-117        | 3" x 1-1/2"     | 10/20                    | 66                   |
| 510-118             | 520-118        | 3" x 2"         | NA/10                    | 37                   |
| 510-119             | 520-119        | 3" x 2-1/2"     | NA/8                     | 24                   |
| 510-111             | 520-111        | 4" x 2"         | NA/6                     | 36                   |
| 510-113             | 520-113        | 4" x 2-1/2"     | 4/8                      | 51                   |
| 510-112             | 520-112        | 4" x 3"         | 3/9                      | 69                   |

**ELBOW • SIDE OUTLET**

**MALLEABLE IRON**



| Galvanized Part No. | Black Part No. | Size   | Inner/Master Carton Qty. | Master Weight (lbs.) |
|---------------------|----------------|--------|--------------------------|----------------------|
| 510-803             | 520-803        | 1/2"   | 45/135                   | 46                   |
| 510-804             | 520-804        | 3/4"   | 40/80                    | 41                   |
| 510-805             | 520-805        | 1"     | 20/80                    | 59                   |
| 510-806             | 520-806        | 1-1/4" | 15/45                    | 54                   |
| 510-807             | 520-807        | 1-1/2" | 18/36                    | 50                   |
| 510-808             | 520-808        | 2"     | 12/24                    | 39                   |

**TEE**

**MALLEABLE IRON**



| Galvanized Part No. | Black Part No. | Size   | Inner/Master Carton Qty. | Master Weight (lbs.) |
|---------------------|----------------|--------|--------------------------|----------------------|
| 510-600             | 520-600        | 1/8"   | 75/450                   | 43                   |
| 510-601             | 520-601        | 1/4"   | 50/300                   | 47                   |
| 510-602             | 520-602        | 3/8"   | 45/180                   | 41                   |
| 510-603             | 520-603        | 1/2"   | 40/120                   | 44                   |
| 510-604             | 520-604        | 3/4"   | 35/70                    | 42                   |
| 510-605             | 520-605        | 1"     | 20/40                    | 37                   |
| 510-606             | 520-606        | 1-1/4" | 14/28                    | 39                   |
| 510-607             | 520-607        | 1-1/2" | NA/23                    | 41                   |
| 510-608             | 520-608        | 2"     | 5/15                     | 42                   |
| 510-609             | 520-609        | 2-1/2" | NA/9                     | 40                   |
| 510-610             | 520-610        | 3"     | NA/6                     | 44                   |
| 510-611             | 520-611        | 4"     | NA/3                     | 38                   |
| 510-613             | 520-613        | 6"     | NA/2                     | 55                   |

**SERVICE TEES**

**MALLEABLE IRON**



| Galvanized Part No. | Black Part No. | Size | Inner/Master Carton Qty. | Master Weight (lbs.) |
|---------------------|----------------|------|--------------------------|----------------------|
| 510-683             | 520-683        | 1/2" | 60/240                   | 70                   |
| 510-684             | 520-684        | 3/4" | 50/150                   | 72                   |
| 510-685             | —              | 1"   | 20/80                    | 62                   |



**TEE • REDUCING**

**MALLEABLE IRON**

TUBE & PIPE

METAL FITTINGS & NIPPLES

PLASTIC FITTINGS

VALVES

FILTER-DRIERS & STRAINERS



| Galvanized Part No. | Black Part No. | Size                     | Inner/Master Carton Qty. | Master Weight (lbs.) |
|---------------------|----------------|--------------------------|--------------------------|----------------------|
| 510-229             | 520-229        | 1/4" x 1/8"              | 50/300                   | 38                   |
| 510-220             | 520-220        | 3/8" x 1/8"              | 60/240                   | 40                   |
| 510-221             | 520-221        | 3/8" x 1/4"              | 60/240                   | 55                   |
| 510-330             | 520-330        | 1/2" x 1/8"              | 60/180                   | 46                   |
| 510-331             | 520-331        | 1/2" x 1/4"              | 50/150                   | 41                   |
| 510-322             | 520-322        | 1/2" x 3/8"              | 45/135                   | 40                   |
| 510-334             | 520-334        | 1/2" x 1/2" x 3/4"       | 45/90                    | 39                   |
| 510-335             | 520-335        | 1/2" x 1/2" x 1"         | 30/120                   | 64                   |
| 510-444             | 520-444        | 3/4" x 1/4"              | 50/100                   | 40                   |
| 510-442             | 520-442        | 3/4" x 3/8"              | 45/90                    | 39                   |
| 510-743             | 520-743        | 3/4" x 1/2"              | 45/90                    | 45                   |
| 510-433             | 520-433        | 3/4" x 1/2" x 1/2"       | 45/90                    | 40                   |
| 510-434             | 520-434        | 3/4" x 1/2" x 3/4"       | 45/90                    | 46                   |
| 510-435             | 520-435        | 3/4" x 1/2" x 1"         | 45/90                    | 59                   |
| 510-445             | 520-445        | 3/4" x 3/4" x 1"         | 25/50                    | 35                   |
| 510-446             | 520-446        | 3/4" x 3/4" x 1-1/4"     | 18/72                    | 63                   |
| 510-551             | 520-551        | 1" x 1/4"                | 25/100                   | 61                   |
| 510-552             | 520-552        | 1" x 3/8"                | 20/60                    | 41                   |
| 510-753             | 520-753        | 1" x 1/2"                | 20/60                    | 43                   |
| 510-754             | 520-754        | 1" x 3/4"                | 25/50                    | 40                   |
| 510-533             | 520-533        | 1" x 1/2" x 1/2"         | 20/120                   | 67                   |
| 510-534             | 520-534        | 1" x 1/2" x 3/4"         | 25/100                   | 61                   |
| 510-793             | 520-793        | 1" x 1/2" x 1"           | 20/60                    | 46                   |
| 510-543             | 520-543        | 1" x 3/4" x 1/2"         | 25/100                   | 62                   |
| 510-544             | 520-544        | 1" x 3/4" x 3/4"         | 25/50                    | 35                   |
| 510-545             | —              | 1" x 3/4" x 1"           | 25/50                    | 39                   |
| —                   | 520-794        | 1" x 3/4" x 1"           | 25/50                    | 39                   |
| 510-556             | 520-556        | 1" x 1" x 1-1/4"         | 18/36                    | 38                   |
| 510-557             | 520-557        | 1" x 1" x 1-1/2"         | 13/52                    | 61                   |
| 510-558             | 520-558        | 1" x 1" x 2"             | 9/36                     | 64                   |
| 510-662             | 520-662        | 1-1/4" x 3/8"            | 16/64                    | 53                   |
| 510-663             | 520-663        | 1-1/4" x 1/2"            | 16/64                    | 60                   |
| 510-664             | 520-664        | 1-1/4" x 3/4"            | 18/36                    | 38                   |
| 510-765             | 520-765        | 1-1/4" x 1"              | 16/32                    | 38                   |
| 510-633             | 520-633        | 1-1/4" x 1/2" x 1/2"     | 16/64                    | 46                   |
| 510-634             | 520-634        | 1-1/4" x 1/2" x 3/4"     | 18/72                    | 54                   |
| 510-635             | 520-635        | 1-1/4" x 1/2" x 1"       | 18/72                    | 58                   |
| 510-636             | 520-636        | 1-1/4" x 1/2" x 1-1/4"   | 16/64                    | 68                   |
| 510-643             | 520-643        | 1-1/4" x 3/4" x 1/2"     | 18/72                    | 60                   |
| 510-644             | 520-644        | 1-1/4" x 3/4" x 3/4"     | 18/72                    | 61                   |
| 510-645             | 520-645        | 1-1/4" x 3/4" x 1"       | 16/64                    | 64                   |
| 510-646             | 520-646        | 1-1/4" x 3/4" x 1-1/4"   | 16/32                    | 36                   |
| 510-653             | 520-653        | 1-1/4" x 1" x 1/2"       | 18/72                    | 58                   |
| 510-654             | 520-654        | 1-1/4" x 1" x 3/4"       | 18/72                    | 66                   |
| 510-655             | 520-655        | 1-1/4" x 1" x 1"         | 18/36                    | 37                   |
| 510-656             | 520-656        | 1-1/4" x 1" x 1-1/4"     | 15/30                    | 45                   |
| 510-657             | 520-657        | 1-1/4" x 1" x 1-1/2"     | 15/30                    | 65                   |
| 510-658             | 520-658        | 1-1/4" x 1-1/4" x 1-1/2" | 11/44                    | 69                   |
| 510-659             | 520-659        | 1-1/4" x 1-1/4" x 2"     | 8/32                     | 56                   |
| 510-772             | 520-772        | 1-1/2" x 3/8"            | 18/36                    | 42                   |
| 510-773             | 520-773        | 1-1/2" x 1/2"            | 18/36                    | 43                   |
| 510-774             | 520-774        | 1-1/2" x 3/4"            | 15/30                    | 40                   |
| 510-775             | —              | 1-1/2" x 1"              | 13/26                    | 71                   |
| 510-776             | 520-776        | 1-1/2" x 1-1/4"          | NA/23                    | 39                   |
| —                   | 520-766        | 1-1/2" x 1"              | 13/52                    | 76                   |
| 510-734             | 520-734        | 1-1/2" x 1/2" x 3/4"     | 15/60                    | 58                   |
| 510-735             | 520-735        | 1-1/2" x 1/2" x 1"       | 13/52                    | 53                   |
| 510-736             | 520-736        | 1-1/2" x 1/2" x 1-1/4"   | 11/44                    | 57                   |
| 510-737             | 520-737        | 1-1/2" x 1/2" x 1-1/2"   | 18/36                    | 49                   |



**TEE • REDUCING continued**

**MALLEABLE IRON**



| Galvanized Part No. | Black Part No. | Size                     | Inner/Master Carton Qty. | Master Weight (lbs.) |
|---------------------|----------------|--------------------------|--------------------------|----------------------|
| 510-748             | 520-748        | 1-1/2" x 3/4" x 1/2"     | 15/60                    | 58                   |
| 510-744             | 520-744        | 1-1/2" x 3/4" x 3/4"     | 15/60                    | 61                   |
| 510-746             | 520-746        | 1-1/2" x 3/4" x 1-1/4"   | 11/44                    | 57                   |
| 510-747             | 520-747        | 1-1/2" x 3/4" x 1-1/2"   | 15/30                    | 43                   |
| 510-758             | 520-758        | 1-1/2" x 1" x 1/2"       | 13/52                    | 58                   |
| 510-759             | 520-759        | 1-1/2" x 1" x 3/4"       | 13/52                    | 70                   |
| 510-755             | 520-755        | 1-1/2" x 1" x 1"         | 13/52                    | 61                   |
| 510-756             | 520-756        | 1-1/2" x 1" x 1-1/4"     | 11/44                    | 61                   |
| 510-757             | 520-757        | 1-1/2" x 1" x 1-1/2"     | 13/26                    | 39                   |
| 510-763             | 520-763        | 1-1/2" x 1-1/4" x 1/2"   | 11/44                    | 50                   |
| 510-764             | 520-764        | 1-1/2" x 1-1/4" x 3/4"   | 11/44                    | 52                   |
| 510-767             | 520-767        | 1-1/2" x 1-1/4" x 1-1/2" | 11/44                    | 68                   |
| 510-768             | 520-768        | 1-1/2" x 1-1/4" x 1"     | 11/44                    | 59                   |
| 510-769             | 520-769        | 1-1/2" x 1-1/4" x 1-1/4" | 11/44                    | 66                   |
| 510-783             | 520-783        | 2" x 1/2"                | 10/40                    | 69                   |
| 510-884             | 520-884        | 2" x 3/4"                | 9/36                     | 69                   |
| 510-785             | 520-785        | 2" x 1"                  | 9/18                     | 37                   |
| 510-886             | 520-886        | 2" x 1-1/4"              | 8/16                     | 36                   |
| 510-787             | 520-787        | 2" x 1-1/2"              | 8/16                     | 39                   |
| 510-778             | 520-778        | 2" x 1-1/2" x 2"         | 8/32                     | 66                   |
| 510-838             | 520-838        | 2" x 1/2" x 2"           | 8/32                     | 66                   |
| 510-844             | 520-844        | 2" x 3/4" x 3/4"         | 9/36                     | 47                   |
| 510-848             | 520-848        | 2" x 3/4" x 2"           | 8/32                     | 68                   |
| 510-855             | 520-855        | 2" x 1" x 1"             | 9/36                     | 57                   |
| 510-857             | 520-857        | 2" x 1" x 1-1/2"         | 8/32                     | 66                   |
| 510-858             | 520-858        | 2" x 1" x 2"             | 10/20                    | 45                   |
| 510-865             | 520-865        | 2" x 1-1/4" x 1"         | 8/32                     | 53                   |
| 510-866             | 520-866        | 2" x 1-1/4" x 1-1/4"     | 8/32                     | 58                   |
| 510-867             | 520-867        | 2" x 1-1/4" x 1-1/2"     | 8/32                     | 63                   |
| 510-868             | 520-868        | 2" x 1-1/4" x 2"         | 8/16                     | 39                   |
| 510-874             | 520-874        | 2" x 1-1/2" x 3/4"       | 8/32                     | 50                   |
| 510-875             | 520-875        | 2" x 1-1/2" x 1"         | 8/32                     | 57                   |
| 510-876             | 520-876        | 2" x 1-1/2" x 1-1/4"     | 8/32                     | 61                   |
| 510-877             | 520-877        | 2" x 1-1/2" x 1-1/2"     | 8/16                     | 35                   |
| 510-878             | 520-878        | 2" x 1-1/2" x 2"         | 8/16                     | 37                   |
| 510-889             | 520-889        | 2" x 2" x 2-1/2"         | 10/20                    | 68                   |
| 510-993             | 520-993        | 2-1/2" x 1/2"            | 10/20                    | 62                   |
| 510-994             | 520-994        | 2-1/2" x 3/4"            | 10/20                    | 60                   |

**COUPLING**

**MALLEABLE IRON**



| Galvanized Part No. | Black Part No. | Size   | Inner/Master Carton Qty. | Master Weight (lbs.) |
|---------------------|----------------|--------|--------------------------|----------------------|
| 511-200             | 521-200        | 1/8"   | 60/720                   | 43                   |
| 511-201             | 521-201        | 1/4"   | 40/480                   | 42                   |
| 511-202             | 521-202        | 3/8"   | 50/300                   | 39                   |
| 511-203             | 521-203        | 1/2"   | 60/240                   | 47                   |
| 511-204             | 521-204        | 3/4"   | 50/150                   | 47                   |
| 511-205             | 521-205        | 1"     | 25/75                    | 37                   |
| 511-206             | 521-206        | 1-1/4" | 32/64                    | 45                   |
| 511-207             | 521-207        | 1-1/2" | 18/72                    | 69                   |
| 511-208             | 521-208        | 2"     | 12/24                    | 36                   |
| 511-209             | 521-209        | 2-1/2" | NA/16                    | 43                   |
| 511-210             | 521-210        | 3"     | NA/12                    | 46                   |
| 511-211             | 521-211        | 4"     | NA/7                     | 46                   |
| 511-213             | 521-213        | 6"     | 2/4                      | 50                   |



TUBE & PIPE

METAL FITTINGS & NIPPLES

PLASTIC FITTINGS

VALVES

FILTER-DRIERS & STRAINERS

**COUPLING • REDUCING**

**MALLEABLE IRON**

TUBE & PIPE

METAL FITTINGS  
& NIPPLES

PLASTIC  
FITTINGS

VALVES

FILTER-DRIERS  
& STRAINERS



| Galvanized Part No. | Black Part No. | Size            | Inner/Master Carton Qty. | Master Weight (lbs.) |
|---------------------|----------------|-----------------|--------------------------|----------------------|
| 511-310             | 521-310        | 1/4" x 1/8"     | 25/600                   | 49                   |
| 511-320             | 521-320        | 3/8" x 1/8"     | 30/360                   | 38                   |
| 511-321             | 521-321        | 3/8" x 1/4"     | 30/360                   | 41                   |
| 511-330             | 521-330        | 1/2" x 1/8"     | 50/300                   | 41                   |
| 511-331             | 521-331        | 1/2" x 1/4"     | 50/300                   | 46                   |
| 511-332             | 521-332        | 1/2" x 3/8"     | 40/240                   | 41                   |
| 511-340             | 521-340        | 3/4" x 1/8"     | 35/210                   | 46                   |
| 511-341             | 521-341        | 3/4" x 1/4"     | 30/180                   | 41                   |
| 511-342             | 521-342        | 3/4" x 3/8"     | 30/180                   | 65                   |
| 511-343             | 521-343        | 3/4" x 1/2"     | 60/180                   | 49                   |
| 511-351             | 521-351        | 1" x 1/4"       | 25/200                   | 69                   |
| 511-352             | 521-352        | 1" x 3/8"       | 40/120                   | 44                   |
| 511-353             | 521-353        | 1" x 1/2"       | 30/120                   | 48                   |
| 511-354             | 521-354        | 1" x 3/4"       | 30/120                   | 55                   |
| 511-362             | 521-362        | 1-1/4" x 3/8"   | 50/100                   | 52                   |
| 511-363             | 521-363        | 1-1/4" x 1/2"   | 25/75                    | 40                   |
| 511-364             | 521-364        | 1-1/4" x 3/4"   | 25/75                    | 45                   |
| 511-365             | 521-365        | 1-1/4" x 1"     | 25/75                    | 50                   |
| 511-372             | 521-372        | 1-1/2" x 3/8"   | 20/120                   | 48                   |
| 511-373             | 521-373        | 1-1/2" x 1/2"   | 20/60                    | 42                   |
| 511-374             | 521-374        | 1-1/2" x 3/4"   | 30/60                    | 44                   |
| 511-375             | 521-375        | 1-1/2" x 1"     | 30/60                    | 50                   |
| 511-376             | 521-376        | 1-1/2" x 1-1/4" | 25/50                    | 47                   |
| 511-383             | 521-383        | 2" x 1/2"       | 21/42                    | 47                   |
| 511-384             | 521-384        | 2" x 3/4"       | 21/42                    | 48                   |
| 511-385             | 521-385        | 2" x 1"         | 14/28                    | 35                   |
| 511-386             | 521-386        | 2" x 1-1/4"     | 14/28                    | 37                   |
| 511-387             | 521-387        | 2" x 1-1/2"     | 14/28                    | 38                   |
| 511-394             | 521-394        | 2 1/2" x 3/4"   | NA/20                    | 35                   |
| 511-395             | 521-395        | 2-1/2" x 1"     | 16/32                    | 59                   |
| 511-396             | 521-396        | 2-1/2" x 1-1/4" | 16/32                    | 60                   |
| 511-397             | 521-397        | 2-1/2" x 1-1/2" | 16/32                    | 67                   |
| 511-398             | 521-398        | 2-1/2" x 2"     | 16/32                    | 66                   |
| 511-304             | 521-304        | 3" x 3/4"       | NA/24                    | 58                   |
| 511-305             | 521-305        | 3" x 1"         | 12/24                    | 63                   |
| 511-306             | 521-306        | 3" x 1-1/4"     | 12/24                    | 64                   |
| 511-307             | 521-307        | 3" x 1-1/2"     | 12/24                    | 68                   |
| 511-308             | 521-308        | 3" x 2"         | 7/14                     | 42                   |
| 511-309             | 521-309        | 3" x 2-1/2"     | NA/12                    | 41                   |
| 511-325             | 521-325        | 4" x 1"         | NA/9                     | 36                   |
| 511-326             | 521-326        | 4" x 1-1/4"     | NA/9                     | 41                   |
| 511-327             | 521-327        | 4" x 1-1/2"     | NA/9                     | 39                   |
| 511-328             | 521-328        | 4" x 2"         | NA/9                     | 43                   |
| 511-329             | 521-329        | 4" x 2-1/2"     | NA/9                     | 47                   |
| 511-300             | 521-300        | 4" x 3"         | NA/7                     | 40                   |
| 511-323             | 521-323        | 6" x 4"         | NA/4                     | 38                   |
| 511-322             | 521-322        | 6" x 3"         | NA/4                     | 41                   |



**COUPLING • MERCHANT**

**MALLEABLE IRON**



| Galvanized Part No. | Black Part No. | Size   | Inner/Master Carton Qty. | Master Weight (lbs.) |
|---------------------|----------------|--------|--------------------------|----------------------|
| 511-220             | 521-220        | 1/8"   | 60/720                   | 23                   |
| 511-221             | 521-221        | 1/4"   | 60/720                   | 54                   |
| 511-222             | 521-222        | 3/8"   | 50/600                   | 58                   |
| 511-223             | 521-223        | 1/2"   | 40/480                   | 101                  |
| 511-224             | 521-224        | 3/4"   | 50/300                   | 85                   |
| 511-225             | 521-225        | 1"     | 25/150                   | 50                   |
| 511-226             | 521-226        | 1-1/4" | 16/128                   | 64                   |
| 511-227             | 521-227        | 1-1/2" | 18/72                    | 44                   |
| 511-228             | 521-228        | 2"     | 12/48                    | 40                   |
| 511-229             | —              | 2-1/2" | NA/16                    | 40                   |
| 511-230             | —              | 3"     | NA/12                    | 41                   |
| 511-231             | —              | 4"     | NA/7                     | 31                   |

**CAP**

**MALLEABLE IRON**



| Galvanized Part No. | Black Part No. | Size   | Inner/Master Carton Qty. | Master Weight (lbs.) |
|---------------------|----------------|--------|--------------------------|----------------------|
| 511-400             | 521-400        | 1/8"   | 100/1200                 | 42                   |
| 511-401             | 521-401        | 1/4"   | 75/900                   | 56                   |
| 511-402             | 521-402        | 3/8"   | 60/720                   | 64                   |
| 511-403             | 521-403        | 1/2"   | 75/450                   | 58                   |
| 511-404             | 521-404        | 3/4"   | 40/240                   | 51                   |
| 511-405             | 521-405        | 1"     | 35/140                   | 46                   |
| 511-406             | 521-406        | 1-1/4" | 25/100                   | 49                   |
| 511-407             | 521-407        | 1-1/2" | 25/75                    | 47                   |
| 511-408             | 521-408        | 2"     | 18/54                    | 51                   |
| 511-409             | 521-409        | 2-1/2" | NA/24                    | 38                   |
| 511-410             | 521-410        | 3"     | NA/16                    | 38                   |
| 511-411             | 521-411        | 4"     | NA/10                    | 41                   |
| 511-413             | 521-413        | 6"     | NA/5                     | 44                   |

**PLUG**

**MALLEABLE IRON**



| Galvanized Part No. | Black Part No. | Size   | Inner/Master Carton Qty. | Master Weight (lbs.) |
|---------------------|----------------|--------|--------------------------|----------------------|
| 511-800             | 521-800        | 1/8"   | 225/2700                 | 52                   |
| 511-801             | 521-801        | 1/4"   | 150/1800                 | 54                   |
| 511-802             | 521-802        | 3/8"   | 100/1200                 | 63                   |
| 511-803             | 521-803        | 1/2"   | 25/600                   | 51                   |
| 511-804             | 521-804        | 3/4"   | 15/360                   | 50                   |
| 511-805             | 521-805        | 1"     | 20/240                   | 59                   |
| 511-806             | 521-806        | 1-1/4" | 40/120                   | 48                   |
| 511-807             | 521-807        | 1-1/2" | 30/90                    | 48                   |
| 511-808             | 521-808        | 2"     | 30/60                    | 50                   |
| 511-809             | 521-809        | 2-1/2" | NA/32                    | 37                   |
| 511-810             | 521-810        | 3"     | NA/24                    | 43                   |
| 511-811             | 521-811        | 4"     | NA/16                    | 45                   |
| 511-813             | 521-813        | 6"     | NA/10                    | 71                   |



# HEX BUSHING

# MALLEABLE IRON



| Galvanized Part No. | Black Part No. | Size            | Inner/Master Carton Qty. | Master Weight (lbs.) |
|---------------------|----------------|-----------------|--------------------------|----------------------|
| 511-910             | 521-910        | 1/4" x 1/8"     | 100/1200                 | 65                   |
| 511-920             | 521-920        | 3/8" x 1/8"     | 75/900                   | 40                   |
| 511-921             | 521-921        | 3/8" x 1/4"     | 75/900                   | 39                   |
| 511-930             | 521-930        | 1/2" x 1/8"     | 150/600                  | 58                   |
| 511-931             | 521-931        | 1/2" x 1/4"     | 100/600                  | 54                   |
| 511-932             | 521-932        | 1/2" x 3/8"     | 100/600                  | 43                   |
| 511-940             | 521-940        | 3/4" x 1/8"     | 50/300                   | 44                   |
| 511-941             | 521-941        | 3/4" x 1/4"     | 50/300                   | 50                   |
| 511-942             | 521-942        | 3/4" x 3/8"     | 50/300                   | 46                   |
| 511-943             | 521-943        | 3/4" x 1/2"     | 50/300                   | 39                   |
| 511-951             | 521-951        | 1" x 1/4"       | 50/200                   | 41                   |
| 511-952             | 521-952        | 1" x 3/8"       | 50/200                   | 54                   |
| 511-953             | 521-953        | 1" x 1/2"       | 50/200                   | 50                   |
| 511-954             | 521-954        | 1" x 3/4"       | 50/200                   | 39                   |
| 511-961             | 521-961        | 1-1/4" x 1/4"   | 30/240                   | 69                   |
| 511-962             | 521-962        | 1-1/4" x 3/8"   | 30/240                   | 67                   |
| 511-963             | 521-963        | 1-1/4" x 1/2"   | 30/120                   | 57                   |
| 511-964             | 521-964        | 1-1/4" x 3/4"   | 30/120                   | 107                  |
| 511-965             | 521-965        | 1-1/4" x 1"     | 30/120                   | 39                   |
| 511-971             | 521-971        | 1-1/2" x 1/4"   | 25/150                   | 61                   |
| 511-972             | 521-972        | 1-1/2" x 3/8"   | 25/150                   | 62                   |
| 511-973             | 521-973        | 1-1/2" x 1/2"   | 25/75                    | 49                   |
| 511-974             | 521-974        | 1-1/2" x 3/4"   | 25/75                    | 43                   |
| 511-975             | 521-975        | 1-1/2" x 1"     | 25/75                    | 43                   |
| 511-976             | 521-976        | 1-1/2" x 1-1/4" | 25/150                   | 50                   |
| 511-982             | 521-982        | 2" x 3/8"       | 20/60                    | 39                   |
| 511-983             | 521-983        | 2" x 1/2"       | 20/60                    | 54                   |
| 511-984             | 521-984        | 2" x 3/4"       | 20/60                    | 62                   |
| 511-985             | 521-985        | 2" x 1"         | 20/60                    | 63                   |
| 511-986             | 521-986        | 2" x 1-1/4"     | 20/60                    | 51                   |
| 511-987             | 521-987        | 2" x 1-1/2"     | 20/60                    | 42                   |
| 511-993             | 521-993        | 2-1/2" x 1/2"   | 30/60                    | 59                   |
| 511-994             | 521-994        | 2-1/2"x3/4"     | 24/48                    | 41                   |
| 511-995             | 521-995        | 2-1/2" x 1"     | 24/48                    | 46                   |
| 511-996             | 521-996        | 2-1/2" x 1-1/4" | 24/48                    | 52                   |
| 511-997             | 521-997        | 2-1/2" x 1-1/2" | 0/28                     | 33                   |
| 511-998             | 521-998        | 2-1/2" x 2"     | 24/48                    | 51                   |
| 511-903             | 521-903        | 3" x 1/2"       | 24/48                    | 75                   |
| 511-904             | 521-904        | 3" x 3/4"       | NA/24                    | 35                   |
| 511-905             | 521-905        | 3" x 1"         | 16/32                    | 44                   |
| 511-906             | 521-906        | 3" x 1-1/4"     | 16/32                    | 49                   |
| 511-907             | 521-907        | 3" x 1-1/2"     | 16/32                    | 51                   |
| 511-908             | 521-908        | 3" x 2"         | 0/16                     | 40                   |
| 511-909             | 521-909        | 3" x 2-1/2"     | 16/32                    | 53                   |
| 511-914             | 521-914        | 4" x 3/4"       | 10/20                    | 50                   |
| 511-915             | 521-915        | 4" x 1"         | 10/20                    | 51                   |
| 511-916             | 521-916        | 4" x 1-1/4"     | 10/20                    | 47                   |
| 511-917             | 521-917        | 4" x 1-1/2"     | 10/20                    | 47                   |
| 511-918             | 521-918        | 4" x 2"         | 10/20                    | 58                   |
| 511-919             | 521-919        | 4" x 2-1/2"     | NA/10                    | 46                   |
| 511-900             | 521-900        | 4" x 3"         | NA/10                    | 35                   |
| 511-938             | 521-938        | 6" x 2"         | NA/10                    | 67                   |
| 511-939             | 521-939        | 6" x 3"         | NA/10                    | 70                   |
| 511-937             | 521-937        | 6" x 4"         | NA/10                    | 74                   |

TUBE & PIPE

METAL FITTINGS & NIPPLES

PLASTIC FITTINGS

VALVES

FILTER-DRIERS & STRAINERS



## UNION

## MALLEABLE IRON



| Galvanized Part No. | Black Part No. | Size   | Inner/Master Carton Qty. | Master Weight (lbs.) |
|---------------------|----------------|--------|--------------------------|----------------------|
| 511-700             | 521-700        | 1/8"   | 20/240                   | 41                   |
| 511-701             | 521-701        | 1/4"   | 30/180                   | 46                   |
| 511-702             | 521-702        | 3/8"   | 35/140                   | 48                   |
| 511-703             | 521-703        | 1/2"   | 25/100                   | 49                   |
| 511-704             | 521-704        | 3/4"   | 20/60                    | 39                   |
| 511-705             | 521-705        | 1"     | 15/45                    | 44                   |
| 511-706             | 521-706        | 1-1/4" | 15/30                    | 41                   |
| 511-707             | 521-707        | 1-1/2" | 10/20                    | 36                   |
| 511-708             | 521-708        | 2"     | 6/24                     | 64                   |
| 511-709             | 521-709        | 2-1/2" | 8/16                     | 67                   |
| 511-710             | 521-710        | 3"     | 5/10                     | 58                   |
| 511-711             | 521-711        | 4"     | 3/6                      | 62                   |

## FLANGE

## MALLEABLE IRON



| Galvanized Part No. | Black Part No. | Size   | Inner/Master Carton Qty. | Master Weight (lbs.) |
|---------------------|----------------|--------|--------------------------|----------------------|
| 511-601             | 521-601        | 1/4"   | 50/200                   | 61                   |
| 511-602             | 521-602        | 3/8"   | 35/140                   | 40                   |
| 511-603             | 521-603        | 1/2"   | 25/100                   | 40                   |
| 511-604             | 521-604        | 3/4"   | 20/80                    | 43                   |
| 511-605             | 521-605        | 1"     | 20/60                    | 48                   |
| 511-606             | 521-606        | 1-1/4" | 15/45                    | 45                   |
| 511-607             | 521-607        | 1-1/2" | 12/36                    | 46                   |
| 511-608             | 521-608        | 2"     | 8/24                     | 44                   |
| 511-610             | 521-610        | 3"     | 24/48                    | 48                   |

## CROSS

## MALLEABLE IRON



| Galvanized Part No. | Black Part No. | Size   | Inner/Master Carton Qty. | Master Weight (lbs.) |
|---------------------|----------------|--------|--------------------------|----------------------|
| 511-000             | 521-000        | 1/8"   | 60/360                   |                      |
| 511-001             | 521-001        | 1/4"   | 45/270                   | 53                   |
| 511-002             | 521-002        | 3/8"   | 45/135                   | 37                   |
| 511-003             | 521-003        | 1/2"   | 45/90                    | 39                   |
| 511-004             | 521-004        | 3/4"   | 30/60                    | 40                   |
| 511-005             | 521-005        | 1"     | 16/32                    | 38                   |
| 511-006             | 521-006        | 1-1/4" | 9/36                     | 57                   |
| 511-007             | 521-007        | 1-1/2" | 8/32                     | 65                   |
| 511-008             | 521-008        | 2"     | 5/20                     | 64                   |
| 511-009             | 521-009        | 2-1/2" | 6/12                     | 61                   |
| 511-010             | 521-010        | 3"     | 4/8                      | 66                   |
| 511-011             | 521-011        | 4"     | 2/4                      | 55                   |

## LOCKNUT

## MALLEABLE IRON

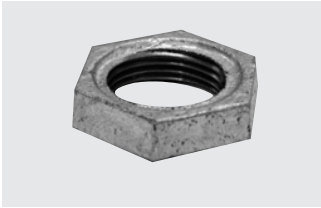

| Galvanized Part No. | Black Part No. | Size   | Inner/Master Carton Qty. | Master Weight (lbs.) |
|---------------------|----------------|--------|--------------------------|----------------------|
| 510-900             | 520-900        | 1/8"   | 250/3000                 | 45                   |
| 510-901             | 520-901        | 1/4"   | 125/1500                 | 42                   |
| 510-902             | 520-902        | 3/8"   | 125/1500                 | 69                   |
| 510-903             | 520-903        | 1/2"   | 100/600                  | 39                   |
| 510-904             | 520-904        | 3/4"   | 60/360                   | 36                   |
| 510-905             | 520-905        | 1"     | 60/240                   | 40                   |
| 510-906             | 520-906        | 1-1/4" | 60/180                   | 41                   |
| 510-907             | 520-907        | 1-1/2" | 40/160                   | 42                   |
| 510-908             | 520-908        | 2"     | 25/150                   | 81                   |
| 510-909             | 520-909        | 2-1/2" | 40/80                    | 57                   |

## NIPPLES

## STANDARD WELDED STEEL



### 1/8"

| Galvanized Part No. | Black Part No. | Description   | Weight Approx. (Lbs.) | Inner Box | Master Ctn. | Inner/Master Wt.(Lbs.) |
|---------------------|----------------|---------------|-----------------------|-----------|-------------|------------------------|
| 560-001             | 580-001        | 1/8" x Close  | 0.02                  | 25        | 100         | 1.8                    |
| 560-015             | 580-015        | 1/8" x 1-1/2" | 0.03                  | 25        | 100         | 3.1                    |
| 560-020             | 580-020        | 1/8" x 2"     | 0.04                  | 25        | 100         | 4.2                    |
| 560-025             | 580-025        | 1/8" x 2-1/2" | 0.05                  | 25        | 100         | 5.1                    |
| 560-030             | 580-030        | 1/8" x 3"     | 0.06                  | 25        | 100         | 6.2                    |
| 560-035             | 580-035        | 1/8" x 3-1/2" | 0.07                  | 25        | 100         | 7.3                    |
| 560-040             | 580-040        | 1/8" x 4"     | 0.08                  | 25        | 100         | 8.4                    |
| 560-045             | 580-045        | 1/8" x 4-1/2" | 0.09                  | 25        | 100         | 9.3                    |
| 560-050             | 580-050        | 1/8" x 5"     | 0.10                  | 25        | 100         | 10.4                   |
| 560-055             | 580-055        | 1/8" x 5-1/2" | 0.11                  | 25        | 100         | 11.5                   |
| 560-060             | 580-060        | 1/8" x 6"     | 0.12                  | 25        | 100         | 12.4                   |
| 560-080             | 580-080        | 1/8" x 8"     | 0.17                  | 25        | -           | 4.1                    |
| 560-100             | 580-100        | 1/8" x 10"    | 0.21                  | 25        | -           | 5.2                    |
| 560-120             | 580-120        | 1/8" x 12"    | 0.25                  | 25        | -           | 6.2                    |

### 1/4"

| Galvanized Part No. | Black Part No. | Description   | Weight Approx. (Lbs.) | Inner Box | Master Ctn. | Inner/Master Wt.(Lbs.) |
|---------------------|----------------|---------------|-----------------------|-----------|-------------|------------------------|
| 561-001             | 581-001        | 1/4" x Close  | 0.03                  | 25        | 100         | 3.1                    |
| 561-015             | 581-015        | 1/4" x 1-1/2" | 0.05                  | 25        | 100         | 5.3                    |
| 561-020             | 581-020        | 1/4" x 2"     | 0.07                  | 25        | 100         | 7.1                    |
| 561-025             | 581-025        | 1/4" x 2-1/2" | 0.09                  | 25        | 100         | 8.8                    |
| 561-030             | 581-030        | 1/4" x 3"     | 0.11                  | 25        | 100         | 10.6                   |
| 561-035             | 581-035        | 1/4" x 3-1/2" | 0.12                  | 25        | 100         | 12.4                   |
| 561-040             | 581-040        | 1/4" x 4"     | 0.14                  | 25        | 100         | 14.1                   |
| 561-045             | 581-045        | 1/4" x 4-1/2" | 0.16                  | 25        | 100         | 15.9                   |
| 561-050             | 581-050        | 1/4" x 5"     | 0.18                  | 25        | 100         | 17.6                   |
| 561-055             | 581-055        | 1/4" x 5-1/2" | 0.19                  | 25        | 100         | 19.4                   |
| 561-060             | 581-060        | 1/4" x 6"     | 0.21                  | 25        | 100         | 21.2                   |
| 561-080             | 581-080        | 1/4" x 8"     | 0.28                  | 25        | -           | 7.1                    |
| 561-100             | 581-100        | 1/4" x 10"    | 0.35                  | 25        | -           | 8.8                    |
| 561-120             | 581-120        | 1/4" x 12"    | 0.42                  | 25        | -           | 10.6                   |

TUBE & PIPE

METAL FITTINGS & NIPPLES

PLASTIC FITTINGS

VALVES

FILTER-DRIERS & STRAINERS



## NIPPLES

## STANDARD WELDED STEEL

**3/8"**

| Galvanized Part No. | Black Part No. | Description   | Weight Aprox. (Lbs.) | Inner Box | Master Ctn. | Inner/Master Wt.(Lbs.) |
|---------------------|----------------|---------------|----------------------|-----------|-------------|------------------------|
| 562-001             | 582-001        | 3/8" x Close  | 0.05                 | 25        | 100         | 4.6                    |
| 562-015             | 582-015        | 3/8" x 1-1/2" | 0.07                 | 25        | 100         | 7.1                    |
| 562-020             | 582-020        | 3/8" x 2"     | 0.09                 | 25        | 100         | 9.5                    |
| 562-025             | 582-025        | 3/8" x 2-1/2" | 0.12                 | 25        | 100         | 11.7                   |
| 562-030             | 582-030        | 3/8" x 3"     | 0.14                 | 25        | 100         | 14.1                   |
| 562-035             | 582-035        | 3/8" x 3-1/2" | 0.17                 | 25        | 100         | 16.5                   |
| 562-040             | 582-040        | 3/8" x 4"     | 0.19                 | 25        | 100         | 18.7                   |
| 562-045             | 582-045        | 3/8" x 4-1/2" | 0.21                 | 25        | 100         | 21.2                   |
| 562-050             | 582-050        | 3/8" x 5"     | 0.24                 | 25        | 100         | 23.6                   |
| 562-055             | 582-055        | 3/8" x 5-1/2" | 0.26                 | 25        | 100         | 25.8                   |
| 562-060             | 582-060        | 3/8" x 6"     | 0.28                 | 25        | 100         | 28.2                   |
| 562-080             | 582-080        | 3/8" x 8"     | 0.38                 | 25        | -           | 9.4                    |
| 562-100             | 582-100        | 3/8" x 10"    | 0.47                 | 25        | -           | 11.7                   |
| 562-120             | 582-120        | 3/8" x 12"    | 0.56                 | 25        | -           | 14.1                   |

**1/2"**

| Galvanized Part No. | Black Part No. | Description   | Weight Aprox. (Lbs.) | Inner Box | Master Ctn. | Inner/Master Wt.(Lbs.) |
|---------------------|----------------|---------------|----------------------|-----------|-------------|------------------------|
| 563-001             | 583-001        | 1/2" x Close  | 0.08                 | 25        | 100         | 7.9                    |
| 563-015             | 583-015        | 1/2" x 1-1/2" | 0.11                 | 25        | 100         | 10.6                   |
| 563-020             | 583-020        | 1/2" x 2"     | 0.14                 | 25        | 100         | 14.3                   |
| 563-025             | 583-025        | 1/2" x 2-1/2" | 0.18                 | 25        | -           | 4.5                    |
| 563-030             | 583-030        | 1/2" x 3"     | 0.21                 | 25        | -           | 5.3                    |
| 563-035             | 583-035        | 1/2" x 3-1/2" | 0.25                 | 25        | -           | 6.2                    |
| 563-040             | 583-040        | 1/2" x 4"     | 0.28                 | 25        | -           | 7.1                    |
| 563-045             | 583-045        | 1/2" x 4-1/2" | 0.32                 | 25        | -           | 8.0                    |
| 563-050             | 583-050        | 1/2" x 5"     | 0.35                 | 25        | -           | 8.9                    |
| 563-055             | 583-055        | 1/2" x 5-1/2" | 0.39                 | 25        | -           | 9.8                    |
| 563-060             | 583-060        | 1/2" x 6"     | 0.43                 | 25        | -           | 10.7                   |
| 563-070             | 583-070        | 1/2" x 7"     | 0.50                 | 25        | -           | 12.5                   |
| 563-080             | 583-080        | 1/2" x 8"     | 0.57                 | 25        | -           | 14.2                   |
| 563-090             | 583-090        | 1/2" x 9"     | 0.64                 | 25        | -           | 16.0                   |
| 563-100             | 583-100        | 1/2" x 10"    | 0.71                 | 25        | -           | 17.8                   |
| 563-110             | 583-110        | 1/2" x 11"    | 0.78                 | 25        | -           | 19.6                   |
| 563-120             | 583-120        | 1/2" x 12"    | 0.85                 | 25        | -           | 21.3                   |

**3/4"**

| Galvanized Part No. | Black Part No. | Description   | Weight Aprox. (Lbs.) | Inner Box | Master Ctn. | Inner/Master Wt.(Lbs.) |
|---------------------|----------------|---------------|----------------------|-----------|-------------|------------------------|
| 564-001             | 584-001        | 3/4" x Close  | 0.13                 | 25        | 100         | 13.0                   |
| 564-015             | 584-015        | 3/4" x 1-1/2" | 0.14                 | 25        | 100         | 14.1                   |
| 564-020             | 584-020        | 3/4" x 2"     | 0.19                 | 25        | -           | 4.7                    |
| 564-025             | 584-025        | 3/4" x 2-1/2" | 0.24                 | 25        | -           | 5.9                    |
| 564-030             | 584-030        | 3/4" x 3"     | 0.28                 | 25        | -           | 7.1                    |
| 564-035             | 584-035        | 3/4" x 3-1/2" | 0.33                 | 25        | -           | 8.3                    |
| 564-040             | 584-040        | 3/4" x 4"     | 0.38                 | 25        | -           | 9.5                    |
| 564-045             | 584-045        | 3/4" x 4-1/2" | 0.43                 | 25        | -           | 10.6                   |
| 564-050             | 584-050        | 3/4" x 5"     | 0.47                 | 25        | -           | 11.9                   |
| 564-055             | 584-055        | 3/4" x 5-1/2" | 0.52                 | 25        | -           | 13.0                   |
| 564-060             | 584-060        | 3/4" x 6"     | 0.57                 | 25        | -           | 14.2                   |
| 564-070             | 584-070        | 3/4" x 7"     | 0.66                 | 25        | -           | 16.5                   |
| 564-080             | 584-080        | 3/4" x 8"     | 0.76                 | 25        | -           | 18.9                   |
| 564-090             | 584-090        | 3/4" x 9"     | 0.85                 | 25        | -           | 21.3                   |
| 564-100             | 584-100        | 3/4" x 10"    | 0.95                 | 25        | -           | 23.6                   |
| 564-110             | 584-110        | 3/4" x 11"    | 1.04                 | 25        | -           | 26.0                   |
| 564-120             | 584-120        | 3/4" x 12"    | 1.14                 | 25        | -           | 28.4                   |

## NIPPLES

## STANDARD WELDED STEEL



1"



| Galvanized Part No. | Black Part No. | Description | Weight Approx. (Lbs.) | Inner Box | Master Ctn. | Inner/Master Wt.(Lbs.) |
|---------------------|----------------|-------------|-----------------------|-----------|-------------|------------------------|
| 565-001             | 585-001        | 1" x Close  | 0.21                  | 25        | -           | 5.2                    |
| 565-020             | 585-020        | 1" x 2"     | 0.28                  | 25        | -           | 7.0                    |
| 565-025             | 585-025        | 1" x 2-1/2" | 0.35                  | 25        | -           | 8.8                    |
| 565-030             | 585-030        | 1" x 3"     | 0.42                  | 25        | -           | 10.5                   |
| 565-035             | 585-035        | 1" x 3-1/2" | 0.49                  | 25        | -           | 12.2                   |
| 565-040             | 585-040        | 1" x 4"     | 0.56                  | 25        | -           | 14.0                   |
| 565-045             | 585-045        | 1" x 4-1/2" | 0.63                  | 25        | -           | 15.8                   |
| 565-050             | 585-050        | 1" x 5"     | 0.70                  | 25        | -           | 17.5                   |
| 565-055             | 585-055        | 1" x 5-1/2" | 0.77                  | 25        | -           | 19.2                   |
| 565-060             | 585-060        | 1" x 6"     | 0.84                  | 25        | -           | 21.0                   |
| 565-070             | 585-070        | 1" x 7"     | 0.98                  | 25        | -           | 24.5                   |
| 565-080             | 585-080        | 1" x 8"     | 1.12                  | 25        | -           | 28.0                   |
| 565-090             | 585-090        | 1" x 9"     | 1.26                  | 25        | -           | 31.5                   |
| 565-100             | 585-100        | 1" x 10"    | 1.40                  | 25        | -           | 35.0                   |
| 565-110             | 585-110        | 1" x 11"    | 1.54                  | 25        | -           | 38.5                   |
| 565-120             | 585-120        | 1" x 12"    | 1.68                  | 25        | -           | 42.0                   |

1-1/4"

| Galvanized Part No. | Black Part No. | Description     | Weight Approx. (Lbs.) | Inner Box | Master Ctn. | Inner/Master Wt.(Lbs.) |
|---------------------|----------------|-----------------|-----------------------|-----------|-------------|------------------------|
| 566-001             | 586-001        | 1-1/4" x Close  | 0.31                  | 25        | -           | 7.7                    |
| 566-020             | 586-020        | 1-1/4" x 2"     | 0.38                  | 25        | -           | 9.5                    |
| 566-025             | 586-025        | 1-1/4" x 2-1/2" | 0.47                  | 25        | -           | 11.9                   |
| 566-030             | 586-030        | 1-1/4" x 3"     | 0.57                  | 25        | -           | 14.2                   |
| 566-035             | 586-035        | 1-1/4" x 3-1/2" | 0.66                  | 25        | -           | 16.6                   |
| 566-040             | 586-040        | 1-1/4" x 4"     | 0.76                  | 25        | -           | 19.0                   |
| 566-045             | 586-045        | 1-1/4" x 4-1/2" | 0.85                  | 25        | -           | 21.3                   |
| 566-050             | 586-050        | 1-1/4" x 5"     | 0.95                  | 25        | -           | 23.7                   |
| 566-055             | 586-055        | 1-1/4" x 5-1/2" | 1.05                  | 25        | -           | 26.1                   |
| 566-060             | 586-060        | 1-1/4" x 6"     | 1.14                  | 25        | -           | 28.5                   |
| 566-070             | 586-070        | 1-1/4" x 7"     | 1.33                  | 25        | -           | 33.2                   |
| 566-080             | 586-080        | 1-1/4" x 8"     | 1.52                  | 25        | -           | 38.0                   |
| 566-090             | 586-090        | 1-1/4" x 9"     | 1.71                  | 25        | -           | 42.7                   |
| 566-100             | 586-100        | 1-1/4" x 10"    | 1.90                  | 25        | -           | 47.5                   |
| 566-110             | 586-110        | 1-1/4" x 11"    | 2.09                  | 10        | -           | 20.9                   |
| 566-120             | 586-120        | 1-1/4" x 12"    | 2.28                  | 10        | -           | 22.8                   |

1-1/2"

| Galvanized Part No. | Black Part No. | Description     | Weight Approx. (Lbs.) | Inner Box | Master Ctn. | Inner/Master Wt.(Lbs.) |
|---------------------|----------------|-----------------|-----------------------|-----------|-------------|------------------------|
| 567-001             | 587-001        | 1-1/2" x Close  | 0.40                  | 25        | -           | 9.9                    |
| 567-020             | 587-020        | 1-1/2" x 2"     | 0.45                  | 25        | -           | 11.4                   |
| 567-025             | 587-025        | 1-1/2" x 2-1/2" | 0.57                  | 25        | -           | 14.2                   |
| 567-030             | 587-030        | 1-1/2" x 3"     | 0.68                  | 25        | -           | 17.0                   |
| 567-035             | 587-035        | 1-1/2" x 3-1/2" | 0.79                  | 25        | -           | 19.8                   |
| 567-040             | 587-040        | 1-1/2" x 4"     | 0.91                  | 25        | -           | 22.7                   |
| 567-045             | 587-045        | 1-1/2" x 4-1/2" | 1.02                  | 25        | -           | 25.5                   |
| 567-050             | 587-050        | 1-1/2" x 5"     | 1.13                  | 25        | -           | 28.3                   |
| 567-055             | 587-055        | 1-1/2" x 5-1/2" | 1.25                  | 25        | -           | 31.2                   |
| 567-060             | 587-060        | 1-1/2" x 6"     | 1.36                  | 25        | -           | 34.0                   |
| 567-070             | 587-070        | 1-1/2" x 7"     | 1.59                  | 10        | -           | 15.9                   |
| 567-080             | 587-080        | 1-1/2" x 8"     | 1.81                  | 10        | -           | 18.1                   |
| 567-090             | 587-090        | 1-1/2" x 9"     | 2.04                  | 10        | -           | 20.4                   |
| 567-100             | 587-100        | 1-1/2" x 10"    | 2.27                  | 10        | -           | 22.7                   |
| 567-110             | 587-110        | 1-1/2" x 11"    | 2.49                  | 10        | -           | 24.9                   |
| 567-120             | 587-120        | 1-1/2" x 12"    | 2.72                  | 10        | -           | 27.2                   |



## NIPPLES

## STANDARD WELDED STEEL



## 2"

| Galvanized Part No. | Black Part No. | Description | Weight Approx. (Lbs.) | Inner Box | Master Ctn. | Inner/Master Wt.(Lbs.) |
|---------------------|----------------|-------------|-----------------------|-----------|-------------|------------------------|
| 568-001             | 588-001        | 2" x Close  | 0.61                  | 25        | -           | 15.2                   |
| 568-025             | 588-025        | 2" x 2-1/2" | 0.76                  | 25        | -           | 19.0                   |
| 568-030             | 588-030        | 2" x 3"     | 0.91                  | 25        | -           | 22.8                   |
| 568-035             | 588-035        | 2" x 3-1/2" | 1.07                  | 25        | -           | 26.7                   |
| 568-040             | 588-040        | 2" x 4"     | 1.22                  | 25        | -           | 30.5                   |
| 568-045             | 588-045        | 2" x 4-1/2" | 1.37                  | 25        | -           | 34.3                   |
| 568-050             | 588-050        | 2" x 5"     | 1.52                  | 25        | -           | 38.1                   |
| 568-055             | 588-055        | 2" x 5-1/2" | 1.68                  | 25        | -           | 41.9                   |
| 568-060             | 588-060        | 2" x 6"     | 1.83                  | 25        | -           | 45.7                   |
| 568-070             | 588-070        | 2" x 7"     | 2.13                  | 10        | -           | 21.3                   |
| 568-080             | 588-080        | 2" x 8"     | 2.44                  | 10        | -           | 24.4                   |
| 568-090             | 588-090        | 2" x 9"     | 2.74                  | 10        | -           | 27.4                   |
| 568-100             | 588-100        | 2" x 10"    | 3.05                  | 10        | -           | 30.5                   |
| 568-110             | 588-110        | 2" x 11"    | 3.35                  | 10        | -           | 33.5                   |
| 568-120             | 588-120        | 2" x 12"    | 3.66                  | 10        | -           | 36.6                   |

## 2-1/2"

| Galvanized Part No. | Black Part No. | Description    | Weight Approx. (Lbs.) | Inner Box | Master Ctn. | Inner/Master Wt.(Lbs.) |
|---------------------|----------------|----------------|-----------------------|-----------|-------------|------------------------|
| 569-001             | —              | 2-1/2" x Close | 1.21                  | 10        | -           | 12.1                   |
| 569-030             | —              | 2-1/2" x 3"    | 1.45                  | 10        | -           | 14.5                   |
| 569-040             | —              | 2-1/2" x 4"    | 1.93                  | 10        | -           | 19.3                   |
| 569-050             | —              | 2-1/2" x 5"    | 2.42                  | 10        | -           | 24.2                   |
| 569-060             | —              | 2-1/2" x 6"    | 2.90                  | 10        | -           | 29.0                   |
| 569-080             | —              | 2-1/2" x 8"    | 3.86                  | 10        | -           | 38.6                   |
| 569-100             | —              | 2-1/2" x 10"   | 4.83                  | 5         | -           | 24.2                   |
| 569-120             | —              | 2-1/2" x 12"   | 5.80                  | 5         | -           | 29.0                   |

## 3"

| Galvanized Part No. | Black Part No. | Description | Weight Approx. (Lbs.) | Inner Box | Master Ctn. | Inner/Master Wt.(Lbs.) |
|---------------------|----------------|-------------|-----------------------|-----------|-------------|------------------------|
| 570-001             | —              | 3" x Close  | 1.66                  | 10        | -           | 16.6                   |
| 570-030             | 590-030        | 3" x 3"     | 1.90                  | 10        | -           | 19.0                   |
| —                   | 590-035        | 3" x 3-1/2" | 2.53                  | 10        | -           | 25.3                   |
| 570-040             | 590-040        | 3" x 4"     | 2.53                  | 10        | -           | 25.3                   |
| 570-050             | 590-050        | 3" x 5"     | 3.16                  | 10        | -           | 31.6                   |
| —                   | 590-055        | 3" x 5-1/2" | 3.48                  | 10        | -           | 34.8                   |
| 570-060             | —              | 3" x 6"     | 3.79                  | 10        | -           | 37.9                   |
| 570-080             | —              | 3" x 8"     | 5.06                  | 5         | -           | 25.3                   |
| 570-100             | 590-100        | 3" x 10"    | 6.32                  | 5         | -           | 31.6                   |
| 570-120             | 590-120        | 3" x 12"    | 7.50                  | 5         | -           | 75.0                   |

## NIPPLES

## STANDARD WELDED STEEL



### 4"

| Galvanized Part No. | Black Part No. | Description | Weight Approx. (Lbs.) | Inner Box | Master Ctn. | Inner/Master Wt.(Lbs.) |
|---------------------|----------------|-------------|-----------------------|-----------|-------------|------------------------|
| 571-001             | #N/A           | 4" x Close  | 2.59                  | 10        | -           | 25.9                   |
| 571-040             | #N/A           | 4" x 4"     | 3.60                  | 6         | -           | 21.6                   |
| 571-050             | #N/A           | 4" x 5"     | 4.50                  | 6         | -           | 27.0                   |
| 571-060             | #N/A           | 4" x 6"     | 5.40                  | 5         | -           | 27.0                   |
| 571-080             | #N/A           | 4" x 8"     | 7.20                  | 3         | -           | 21.6                   |
| 571-100             | #N/A           | 4" x 10"    | 9.00                  | 3         | -           | 27.0                   |
| 571-120             | #N/A           | 4" x 12"    | 10.80                 | 3         | -           | 32.4                   |

TUBE & PIPE

METAL FITTINGS & NIPPLES

PLASTIC FITTINGS

VALVES

FILTER-DRIERS & STRAINERS



## PRE-CUT PIPE

## STANDARD WELDED STEEL

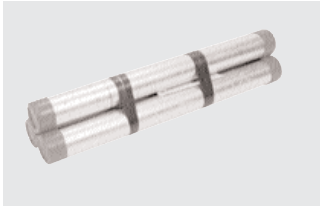
**3/8"**

| Galvanized Part No. | Black Part No. | Description | Weight Approx. (Lbs.) | Inner Box | Master Ctn. | Inner/Master Wt.(Lbs.) |
|---------------------|----------------|-------------|-----------------------|-----------|-------------|------------------------|
| 562-180             | 582-180        | 3/8" x 18"  | 0.85                  | 5         | -           | 4.2                    |
| 562-240             | 582-240        | 3/8" x 24"  | 1.13                  | 5         | -           | 5.6                    |
| 562-300             | 582-300        | 3/8" x 30"  | 1.41                  | 5         | -           | 7.1                    |
| 562-360             | 582-360        | 3/8" x 36"  | 1.69                  | 5         | -           | 8.5                    |
| 562-480             | 582-480        | 3/8" x 48"  | 2.26                  | 5         | -           | 11.3                   |
| 562-600             | 582-600        | 3/8" x 60"  | 2.82                  | 5         | -           | 14.1                   |

**1/2"**

| Galvanized Part No. | Black Part No. | Description | Weight Approx. (Lbs.) | Inner Box | Master Ctn. | Inner/Master Wt.(Lbs.) |
|---------------------|----------------|-------------|-----------------------|-----------|-------------|------------------------|
| 563-180             | 583-180        | 1/2" x 18"  | 1.28                  | 5         | -           | 6.4                    |
| 563-240             | 583-240        | 1/2" x 24"  | 1.71                  | 5         | -           | 8.5                    |
| 563-300             | 583-300        | 1/2" x 30"  | 2.13                  | 5         | -           | 10.7                   |
| 563-360             | 583-360        | 1/2" x 36"  | 2.56                  | 5         | -           | 12.8                   |
| 563-480             | 583-480        | 1/2" x 48"  | 3.41                  | 5         | -           | 17.1                   |
| 563-600             | 583-600        | 1/2" x 60"  | 4.27                  | 5         | -           | 21.3                   |
| 563-720             | 583-720        | 1/2" x 72"  | 5.12                  | 5         | -           | 25.6                   |

**3/4"**

| Galvanized Part No. | Black Part No. | Description | Weight Approx. (Lbs.) | Inner Box | Master Ctn. | Inner/Master Wt.(Lbs.) |
|---------------------|----------------|-------------|-----------------------|-----------|-------------|------------------------|
| 564-180             | 584-180        | 3/4" x 18"  | 1.70                  | 5         | -           | 8.5                    |
| 564-240             | 584-240        | 3/4" x 24"  | 2.27                  | 5         | -           | 11.4                   |
| 564-300             | 584-300        | 3/4" x 30"  | 2.84                  | 5         | -           | 14.2                   |
| 564-360             | 584-360        | 3/4" x 36"  | 3.41                  | 5         | -           | 17.0                   |
| 564-480             | 584-480        | 3/4" x 48"  | 4.54                  | 5         | -           | 22.7                   |
| 564-600             | 584-600        | 3/4" x 60"  | 5.68                  | 5         | -           | 28.4                   |
| 564-720             | 584-720        | 3/4" x 72"  | 6.81                  | 5         | -           | 34.1                   |

**1"**

| Galvanized Part No. | Black Part No. | Description | Weight Approx. (Lbs.) | Inner Box | Master Ctn. | Inner/Master Wt.(Lbs.) |
|---------------------|----------------|-------------|-----------------------|-----------|-------------|------------------------|
| 565-180             | 585-180        | 1" x 18"    | 2.52                  | 3         | -           | 7.6                    |
| 565-240             | 585-240        | 1" x 24"    | 3.36                  | 3         | -           | 10.1                   |
| 565-300             | 585-300        | 1" x 30"    | 4.20                  | 3         | -           | 12.6                   |
| 565-360             | 585-360        | 1" x 36"    | 5.04                  | 3         | -           | 15.1                   |
| 565-480             | 585-480        | 1" x 48"    | 6.72                  | 3         | -           | 20.2                   |
| 565-600             | 585-600        | 1" x 60"    | 8.40                  | 3         | -           | 25.2                   |
| 565-720             | 585-720        | 1" x 72"    | 10.08                 | 3         | -           | 30.2                   |

Cut Pipe in  
2-1/2", 3" & 4"  
available upon request

## PRE-CUT PIPE

## STANDARD WELDED STEEL

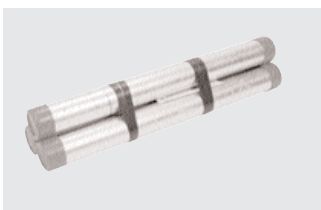

### 1-1/4"

| Galvanized Part No. | Black Part No. | Description  | Weight Approx. (Lbs.) | Inner Box | Master Ctn. | Inner/Master Wt.(Lbs.) |
|---------------------|----------------|--------------|-----------------------|-----------|-------------|------------------------|
| 566-180             | 586-180        | 1-1/4" x 18" | 3.42                  | 3         | -           | 10.3                   |
| 566-240             | 586-240        | 1-1/4" x 24" | 4.55                  | 3         | -           | 13.7                   |
| 566-300             | 586-300        | 1-1/4" x 30" | 5.69                  | 3         | -           | 17.1                   |
| 566-360             | 586-360        | 1-1/4" x 36" | 6.83                  | 3         | -           | 20.5                   |
| 566-480             | 586-480        | 1-1/4" x 48" | 9.11                  | 3         | -           | 27.3                   |
| 566-600             | 586-600        | 1-1/4" x 60" | 11.39                 | 3         | -           | 34.2                   |
| 566-720             | 586-720        | 1-1/4" x 72" | 13.67                 | 3         | -           | 41.0                   |



### 1-1/2"

| Galvanized Part No. | Black Part No. | Description  | Weight Approx. (Lbs.) | Inner Box | Master Ctn. | Inner/Master Wt.(Lbs.) |
|---------------------|----------------|--------------|-----------------------|-----------|-------------|------------------------|
| 567-180             | 587-180        | 1-1/2" x 18" | 4.08                  | 3         | -           | 12.2                   |
| 567-240             | 587-240        | 1-1/2" x 24" | 5.44                  | 3         | -           | 16.3                   |
| 567-300             | 587-300        | 1-1/2" x 30" | 6.80                  | 3         | -           | 20.4                   |
| 567-360             | 587-360        | 1-1/2" x 36" | 8.16                  | 3         | -           | 24.5                   |
| 567-480             | 587-480        | 1-1/2" x 48" | 10.88                 | 3         | -           | 32.7                   |
| 567-600             | 587-600        | 1-1/2" x 60" | 13.60                 | 3         | -           | 40.8                   |
| 567-720             | 587-720        | 1-1/2" x 72" | 16.33                 | 3         | -           | 49.0                   |

### 2"

| Galvanized Part No. | Black Part No. | Description | Weight Approx. (Lbs.) | Inner Box | Master Ctn. | Inner/Master Wt.(Lbs.) |
|---------------------|----------------|-------------|-----------------------|-----------|-------------|------------------------|
| 568-180             | 588-180        | 2" x 18"    | 5.48                  | 3         | -           | 16.4                   |
| 568-240             | 588-240        | 2" x 24"    | 7.31                  | 2         | -           | 14.6                   |
| 568-300             | 588-300        | 2" x 30"    | 9.14                  | 2         | -           | 18.3                   |
| 568-360             | 588-360        | 2" x 36"    | 10.97                 | 2         | -           | 21.9                   |
| 568-480             | 588-480        | 2" x 48"    | 14.62                 | 2         | -           | 29.2                   |
| 568-600             | 588-600        | 2" x 60"    | 18.28                 | 2         | -           | 36.6                   |

Cut Pipe in  
2-1/2", 3" & 4"  
available upon request

TUBE & PIPE

METAL FITTINGS  
& NIPPLES

PLASTIC  
FITTINGS

VALVES

FILTER-DRIERS  
& STRAINERS



## PIPE NIPPLE ASSORTMENTS

## STANDARD WELDED STEEL



## STANDARD PIPE NIPPLE ASSORTMENTS

| Stock Code Galv | Stock Code Black | SIZE | TOTAL PIECES | CLOSE | 1-1/2" | 2" | 2-1/2" | 3" | 3-1/2" | 4" | 4-1/2" | 5" | 5-1/2" | 6" | APROX. WEIGHT LBS. |
|-----------------|------------------|------|--------------|-------|--------|----|--------|----|--------|----|--------|----|--------|----|--------------------|
| 11800           | 21800            | 1/8" | 100          | 20    | 10     | 15 | 10     | 10 | 5      | 10 | 5      | 5  | 5      | 5  | 11                 |
| 11801           | 21801            | 1/4" | 100          | 20    | 10     | 15 | 10     | 10 | 5      | 10 | 5      | 5  | 5      | 5  | 11                 |
| 11802           | 21802            | 3/8" | 100          | 20    | 10     | 15 | 10     | 10 | 5      | 10 | 5      | 5  | 5      | 5  | 12                 |
| 11803           | 21803            | 1/2" | 100          | 20    | 10     | 15 | 10     | 10 | 5      | 10 | 5      | 5  | 5      | 5  | 18                 |
| 11804           | 21804            | 3/4" | 100          | 15    | -      | 20 | 20     | 10 | 5      | 10 | 5      | 5  | 5      | 5  | 24                 |
| 11805           | 21805            | 1"   | 75           | 15    | -      | 12 | 5      | 5  | 3      | 12 | 3      | 5  | 3      | 5  | 28                 |



## SPECIAL "6" PIPE NIPPLE ASSORTMENTS

| Stock Code Galv | Stock Code Black | SIZE   | TOTAL PIECES | CLOSE | 1-1/2" | 2" | 2-1/2" | 3" | 3-1/2" | 4" | 4-1/2" | 5" | 5-1/2" | 6" | APROX. WEIGHT LBS. |
|-----------------|------------------|--------|--------------|-------|--------|----|--------|----|--------|----|--------|----|--------|----|--------------------|
| 11700           | 21700            | 1/8"   | 66           | 6     | 6      | 6  | 6      | 6  | 6      | 6  | 6      | 6  | 6      | 6  | 5                  |
| 11701           | 21701            | 1/4"   | 66           | 6     | 6      | 6  | 6      | 6  | 6      | 6  | 6      | 6  | 6      | 6  | 8                  |
| 11702           | 21702            | 3/8"   | 66           | 6     | 6      | 6  | 6      | 6  | 6      | 6  | 6      | 6  | 6      | 6  | 12                 |
| 11703           | 21703            | 1/2"   | 66           | 6     | 6      | 6  | 6      | 6  | 6      | 6  | 6      | 6  | 6      | 6  | 14                 |
| 11704           | 21704            | 3/4"   | 66           | 6     | 6      | 6  | 6      | 6  | 6      | 6  | 6      | 6  | 6      | 6  | 19                 |
| 11705           | 21705            | 1"     | 60           | 6     | -      | 6  | 6      | 6  | 6      | 6  | 6      | 6  | 6      | 6  | 27                 |
| 11706           | 21706            | 1-1/4" | 60           | 6     | -      | 6  | 6      | 6  | 6      | 6  | 6      | 6  | 6      | 6  | 37                 |
| 11707           | 21707            | 1-1/2" | 60           | 6     | -      | 6  | 6      | 6  | 6      | 6  | 6      | 6  | 6      | 6  | 46                 |
| 11708           | 21708            | 2"     | 54           | 6     | -      | -  | 6      | 6  | 6      | 6  | 6      | 6  | 6      | 6  | 59                 |



## SPECIAL "25" PIPE NIPPLE ASSORTMENTS

| Stock Code Galv | Stock Code Black | SIZE   | TOTAL PIECES | CLOSE | 1-1/2" | 2" | 2-1/2" | 3" | 3-1/2" | 4" | 4-1/2" | 5" | 5-1/2" | 6" | APROX. WEIGHT LBS. |
|-----------------|------------------|--------|--------------|-------|--------|----|--------|----|--------|----|--------|----|--------|----|--------------------|
| 11600           | 21600            | 1/8"   | 25           | 4     | 3      | 3  | 3      | 2  | 2      | 2  | 1      | 2  | 1      | 2  | 1                  |
| 11601           | 21601            | 1/4"   | 25           | 4     | 3      | 3  | 3      | 2  | 2      | 2  | 1      | 2  | 1      | 2  | 2.5                |
| 11602           | 21602            | 3/8"   | 25           | 4     | 3      | 3  | 3      | 2  | 2      | 2  | 1      | 2  | 1      | 2  | 3                  |
| 11603           | 21603            | 1/2"   | 25           | 4     | 3      | 3  | 3      | 2  | 2      | 2  | 1      | 2  | 1      | 2  | 5                  |
| 11604           | 21604            | 3/4"   | 25           | 6     | -      | 4  | 3      | 2  | 2      | 2  | 1      | 2  | 1      | 2  | 6                  |
| 11605           | 21605            | 1"     | 25           | 5     | -      | 5  | 3      | 2  | 2      | 2  | 1      | 2  | 1      | 2  | 9                  |
| 11606           | 21606            | 1-1/4" | 25           | 5     | -      | 5  | 3      | 2  | 2      | 2  | 1      | 2  | 1      | 2  | 12                 |
| 11607           | 21607            | 1-1/2" | 25           | 5     | -      | 5  | 3      | 2  | 2      | 2  | 1      | 2  | 1      | 2  | 15                 |
| 11608           | 21608            | 2"     | 25           | 5     | -      | -  | 4      | 3  | 2      | 3  | 2      | 2  | 2      | 2  | 24                 |

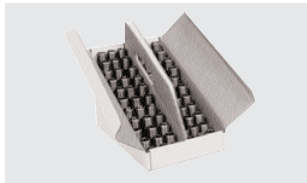

## SLANT-BOX PIPE NIPPLE ASSORTMENTS

| Stock Code Galv | Stock Code Black | SIZE | TOTAL PIECES | CLOSE | 1-1/2" | 2" | 2-1/2" | 3" | 3-1/2" | 4" | 4-1/2" | 5" | 5-1/2" | 6" | APROX. WEIGHT LBS. |
|-----------------|------------------|------|--------------|-------|--------|----|--------|----|--------|----|--------|----|--------|----|--------------------|
| 12000           | 22000            | 1/2" | 66           | 6     | 6      | 6  | 6      | 6  | 6      | 6  | 6      | 6  | 6      | 6  | 15                 |
| 12001           | 22001            | 3/4" | 66           | 6     | 6      | 6  | 6      | 6  | 6      | 6  | 6      | 6  | 6      | 6  | 20                 |
| 12002           | 22002            | 1"   | 60           | 6     | -      | 6  | 6      | 6  | 6      | 6  | 6      | 6  | 6      | 6  | 22                 |

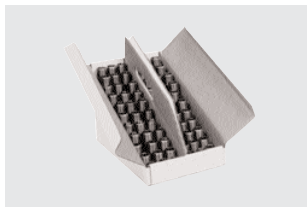

## SINGLE PIPE NIPPLE ASSORTMENTS

| Stock Code Galv | Stock Code Black | SIZE   | TOTAL PIECES | CLOSE | 1-1/2" | 2" | 2-1/2" | 3" | 3-1/2" | 4" | 4-1/2" | 5" | 5-1/2" | 6" | APROX. WEIGHT LBS. |
|-----------------|------------------|--------|--------------|-------|--------|----|--------|----|--------|----|--------|----|--------|----|--------------------|
| 11500           | 21500            | 1/8"   | 11           | 1     | 1      | 1  | 1      | 1  | 1      | 1  | 1      | 1  | 1      | 1  | 1                  |
| 11501           | 21501            | 1/4"   | 11           | 1     | 1      | 1  | 1      | 1  | 1      | 1  | 1      | 1  | 1      | 1  | 1-1/2              |
| 11502           | 21502            | 3/8"   | 11           | 1     | 1      | 1  | 1      | 1  | 1      | 1  | 1      | 1  | 1      | 1  | 2                  |
| 11503           | 21503            | 1/2"   | 11           | 1     | 1      | 1  | 1      | 1  | 1      | 1  | 1      | 1  | 1      | 1  | 2-1/2              |
| 11504           | 21504            | 3/4"   | 11           | 1     | 1      | 1  | 1      | 1  | 1      | 1  | 1      | 1  | 1      | 1  | 3-1/2              |
| 11505           | 21505            | 1"     | 10           | 1     | -      | 1  | 1      | 1  | 1      | 1  | 1      | 1  | 1      | 1  | 5                  |
| 11506           | 21506            | 1-1/4" | 10           | 1     | -      | 1  | 1      | 1  | 1      | 1  | 1      | 1  | 1      | 1  | 7                  |
| 11507           | 21507            | 1-1/2" | 10           | 1     | -      | 1  | 1      | 1  | 1      | 1  | 1      | 1  | 1      | 1  | 8                  |
| 11508           | 21508            | 2"     | 9            | 1     | -      | -  | 1      | 1  | 1      | 1  | 1      | 1  | 1      | 1  | 9                  |

# NIPPLES

# STANDARD SEAMLESS STEEL

TUBE & PIPE

METAL FITTINGS & NIPPLES

PLASTIC FITTINGS

VALVES

FILTER-DRIERS & STRAINERS



## 1/8"

| Black Part No. | Description   | Weight Approx. (Lbs.) | Inner Box | Master Ctn. | Master Wt. (Lbs.) |
|----------------|---------------|-----------------------|-----------|-------------|-------------------|
| 80100          | 1/8" x Close  | 0.0176                | 25        | 100         | 2                 |
| 80101          | 1/8" x 1-1/2" | 0.0309                | 25        | 100         | 3                 |
| 80102          | 1/8" x 2"     | 0.0419                | 25        | 100         | 4                 |
| 80103          | 1/8" x 2-1/2" | 0.0661                | 25        | 100         | 7                 |
| 80104          | 1/8" x 3"     | 0.0617                | 25        | 100         | 6                 |
| 80105          | 1/8" x 3-1/2" | 0.0728                | 25        | 100         | 7                 |
| 80106          | 1/8" x 4"     | 0.0838                | 25        | 100         | 8                 |
| 80107          | 1/8" x 4-1/2" | 0.0926                | 25        | 100         | 9                 |
| 80108          | 1/8" x 5"     | 0.1036                | 25        | 100         | 10                |
| 80109          | 1/8" x 5-1/2" | 0.1146                | 25        | 100         | 11                |
| 80110          | 1/8" x 6"     | 0.1235                | 25        | 100         | 12                |
| 80111          | 1/8" x 7"     | 0.1455                | 100       | -           | 15                |
| 80112          | 1/8" x 8"     | 0.1653                | 100       | -           | 17                |
| 80113          | 1/8" x 9"     | 0.1874                | 100       | -           | 19                |
| 80114          | 1/8" x 10"    | 0.2072                | 100       | -           | 21                |
| 80115          | 1/8" x 11"    | 0.2271                | 100       | -           | 23                |
| 80116          | 1/8" x 12"    | 0.2491                | 100       | -           | 25                |

## 1/4"

| Black Part No. | Description   | Weight Approx. (Lbs.) | Inner Box | Master Ctn. | Master Wt. (Lbs.) |
|----------------|---------------|-----------------------|-----------|-------------|-------------------|
| 80200          | 1/4" x Close  | 0.0309                | 25        | 100         | 3                 |
| 80201          | 1/4" x 1-1/2" | 0.0529                | 25        | 100         | 5                 |
| 80202          | 1/4" x 2"     | 0.0705                | 25        | 100         | 7                 |
| 80203          | 1/4" x 2-1/2" | 0.0882                | 25        | 100         | 9                 |
| 80204          | 1/4" x 3"     | 0.1058                | 25        | 100         | 11                |
| 80205          | 1/4" x 3-1/2" | 0.1235                | 25        | 100         | 12                |
| 80206          | 1/4" x 4"     | 0.1411                | 25        | 100         | 14                |
| 80207          | 1/4" x 4-1/2" | 0.1587                | 25        | 100         | 16                |
| 80208          | 1/4" x 5"     | 0.1764                | 25        | 100         | 18                |
| 80209          | 1/4" x 5-1/2" | 0.1940                | 25        | 100         | 19                |
| 80210          | 1/4" x 6"     | 0.2116                | 25        | 100         | 21                |
| 80211          | 1/4" x 7"     | 0.2469                | 100       | -           | 25                |
| 80212          | 1/4" x 8"     | 0.2822                | 100       | -           | 28                |
| 80213          | 1/4" x 9"     | 0.3175                | 100       | -           | 32                |
| 80214          | 1/4" x 10"    | 0.3527                | 100       | -           | 35                |
| 80215          | 1/4" x 11"    | 0.3880                | 100       | -           | 39                |
| 80216          | 1/4" x 12"    | 0.4233                | 100       | -           | 42                |

## 3/8"

| Black Part No. | Description   | Weight Approx. (Lbs.) | Inner Box | Master Ctn. | Master Wt. (Lbs.) |
|----------------|---------------|-----------------------|-----------|-------------|-------------------|
| 80300          | 3/8" x Close  | 0.0463                | 25        | 100         | 5                 |
| 80301          | 3/8" x 1-1/2" | 0.0705                | 25        | 100         | 7                 |
| 80302          | 3/8" x 2"     | 0.0948                | 25        | 100         | 9                 |
| 80303          | 3/8" x 2-1/2" | 0.1168                | 25        | 100         | 12                |
| 80304          | 3/8" x 3"     | 0.1411                | 25        | 100         | 14                |
| 80305          | 3/8" x 3-1/2" | 0.1653                | 25        | 100         | 17                |
| 80306          | 3/8" x 4"     | 0.1874                | 25        | 100         | 19                |
| 80307          | 3/8" x 4-1/2" | 0.2116                | 25        | 100         | 21                |
| 80308          | 3/8" x 5"     | 0.2359                | 25        | 100         | 24                |
| 80309          | 3/8" x 5-1/2" | 0.2579                | 25        | 100         | 26                |
| 80310          | 3/8" x 6"     | 0.2822                | 25        | 100         | 28                |
| 80311          | 3/8" x 7"     | 0.3285                | 75        | -           | 25                |
| 80312          | 3/8" x 8"     | 0.3770                | 75        | -           | 28                |
| 80313          | 3/8" x 9"     | 0.4233                | 75        | -           | 32                |
| 80314          | 3/8" x 10"    | 0.4696                | 75        | -           | 35                |
| 80315          | 3/8" x 11"    | 0.5181                | 75        | -           | 39                |
| 80316          | 3/8" x 12"    | 0.5644                | 75        | -           | 42                |

**GALVANIZED**  
Seamless & XH Seamless  
Available upon request

**BLACK IRON**  
Schedule 160 & XXH Seamless  
Available upon request



## NIPPLES

## STANDARD SEAMLESS STEEL

**1/2"**

| Black Part No. | Description   | Weight Approx. (Lbs.) | Inner Box | Master Ctn. | Master Wt. (Lbs.) |
|----------------|---------------|-----------------------|-----------|-------------|-------------------|
| 80400          | 1/2" x Close  | 0.0794                | 25        | 100         | 8                 |
| 80401          | 1/2" x 1-1/2" | 0.1058                | 25        | 100         | 11                |
| 80402          | 1/2" x 2"     | 0.1433                | 25        | 100         | 14                |
| 80403          | 1/2" x 2-1/2" | 0.1786                | 25        | 100         | 18                |
| 80404          | 1/2" x 3"     | 0.2138                | 25        | 100         | 21                |
| 80405          | 1/2" x 3-1/2" | 0.2491                | 25        | 100         | 25                |
| 80406          | 1/2" x 4"     | 0.2844                | 25        | 100         | 28                |
| 80407          | 1/2" x 4-1/2" | 0.3197                | 25        | 100         | 32                |
| 80408          | 1/2" x 5"     | 0.3549                | 25        | 100         | 35                |
| 80409          | 1/2" x 5-1/2" | 0.3902                | 25        | 100         | 39                |
| 80410          | 1/2" x 6"     | 0.4277                | 25        | 100         | 43                |
| 80411          | 1/2" x 7"     | 0.4982                | 25        | -           | 12                |
| 80412          | 1/2" x 8"     | 0.5688                | 25        | -           | 14                |
| 80413          | 1/2" x 9"     | 0.6393                | 25        | -           | 16                |
| 80414          | 1/2" x 10"    | 0.7121                | 25        | -           | 18                |
| 80415          | 1/2" x 11"    | 0.7826                | 25        | -           | 20                |
| 80416          | 1/2" x 12"    | 0.8532                | 25        | -           | 21                |

**3/4"**

| Black Part No. | Description   | Weight Approx. (Lbs.) | Inner Box | Master Ctn. | Master Wt. (Lbs.) |
|----------------|---------------|-----------------------|-----------|-------------|-------------------|
| 80500          | 3/4" x Close  | 0.1301                | 25        | 100         | 13                |
| 80501          | 3/4" x 1-1/2" | 0.1411                | 25        | 100         | 14                |
| 80502          | 3/4" x 2"     | 0.1896                | 25        | 100         | 19                |
| 80503          | 3/4" x 2-1/2" | 0.2359                | 25        | 100         | 24                |
| 80504          | 3/4" x 3"     | 0.2844                | 25        | 100         | 28                |
| 80505          | 3/4" x 3-1/2" | 0.3307                | 25        | 100         | 33                |
| 80506          | 3/4" x 4"     | 0.3792                | 25        | 100         | 38                |
| 80507          | 3/4" x 4-1/2" | 0.4255                | 25        | 100         | 43                |
| 80508          | 3/4" x 5"     | 0.4740                | 25        | 100         | 47                |
| 80509          | 3/4" x 5-1/2" | 0.5203                | 25        | 100         | 52                |
| 80510          | 3/4" x 6"     | 0.5688                | 25        | 100         | 57                |
| 80511          | 3/4" x 7"     | 0.6614                | 25        | -           | 17                |
| 80512          | 3/4" x 8"     | 0.7562                | 25        | -           | 19                |
| 80513          | 3/4" x 9"     | 0.8510                | 25        | -           | 21                |
| 80514          | 3/4" x 10"    | 0.9458                | 25        | -           | 24                |
| 80515          | 3/4" x 11"    | 1.0406                | 25        | -           | 26                |
| 80516          | 3/4" x 12"    | 1.1354                | 25        | -           | 28                |

**1"**

| Black Part No. | Description | Weight Approx. (Lbs.) | Inner Box | Master Ctn. | Master Wt. (Lbs.) |
|----------------|-------------|-----------------------|-----------|-------------|-------------------|
| 80600          | 1" x Close  | 0.2094                | 25        | 100         | 5                 |
| 80602          | 1" x 2"     | 0.2800                | 25        | 100         | 7                 |
| 80603          | 1" x 2-1/2" | 0.3505                | 25        | 100         | 9                 |
| 80604          | 1" x 3"     | 0.4189                | 25        | 100         | 10                |
| 80605          | 1" x 3-1/2" | 0.4894                | 25        | 100         | 12                |
| 80606          | 1" x 4"     | 0.5600                | 25        | 100         | 14                |
| 80607          | 1" x 4-1/2" | 0.6305                | 25        | -           | 16                |
| 80608          | 1" x 5"     | 0.6989                | 25        | -           | 17                |
| 80609          | 1" x 5-1/2" | 0.7694                | 25        | -           | 19                |
| 80610          | 1" x 6"     | 0.8400                | 25        | -           | 21                |
| 80611          | 1" x 7"     | 0.9789                | 25        | -           | 24                |
| 80612          | 1" x 8"     | 1.1199                | 25        | -           | 28                |
| 80613          | 1" x 9"     | 1.2588                | 25        | -           | 31                |
| 80614          | 1" x 10"    | 1.3999                | 25        | -           | 35                |
| 80615          | 1" x 11"    | 1.5388                | 25        | -           | 38                |
| 80616          | 1" x 12"    | 1.6799                | 25        | -           | 42                |

**GALVANIZED**  
Seamless & XH Seamless  
Available upon request

**BLACK IRON**  
Schedule 160 & XXH Seamless  
Available upon request

## NIPPLES

## STANDARD SEAMLESS STEEL



### 1-1/2"

| Black Part No. | Description     | Weight (Lbs.) | Inner Box |
|----------------|-----------------|---------------|-----------|
| 80800          | 1-1/2" x Close  | 0.3968        | 25        |
| 80802          | 1-1/2" x 2"     | 0.4542        | 25        |
| 80803          | 1-1/2" x 2-1/2" | 0.5666        | 25        |
| 80804          | 1-1/2" x 3"     | 0.6812        | 25        |
| 80805          | 1-1/2" x 3-1/2" | 0.7937        | 25        |
| 80806          | 1-1/2" x 4"     | 0.9061        | 25        |
| 80807          | 1-1/2" x 4-1/2" | 1.0207        | 25        |
| 80808          | 1-1/2" x 5"     | 1.1332        | 25        |
| 80809          | 1-1/2" x 5-1/2" | 1.2478        | 25        |
| 80810          | 1-1/2" x 6"     | 1.3603        | 25        |
| 80811          | 1-1/2" x 7"     | 1.5873        | 10        |
| 80812          | 1-1/2" x 8"     | 1.8144        | 10        |
| 80813          | 1-1/2" x 9"     | 2.0415        | 10        |
| 80814          | 1-1/2" x 10"    | 2.2686        | 10        |
| 80815          | 1-1/2" x 11"    | 2.4934        | 10        |
| 80816          | 1-1/2" x 12"    | 2.7205        | 10        |

### 2"

| Black Part No. | Description | Weight (Lbs.) | Inner Box |
|----------------|-------------|---------------|-----------|
| 80900          | 2" x Close  | 0.6085        | 25        |
| 80903          | 2" x 2-1/2" | 0.7606        | 25        |
| 80904          | 2" x 3"     | 0.9127        | 25        |
| 80905          | 2" x 3-1/2" | 1.0670        | 25        |
| 80906          | 2" x 4"     | 1.2192        | 25        |
| 80907          | 2" x 4-1/2" | 1.3713        | 25        |
| 80908          | 2" x 5"     | 1.5234        | 25        |
| 80909          | 2" x 5-1/2" | 1.6755        | 25        |
| 80910          | 2" x 6"     | 1.8276        | 25        |
| 80911          | 2" x 7"     | 2.1319        | 10        |
| 80912          | 2" x 8"     | 2.4361        | 10        |
| 80913          | 2" x 9"     | 2.7403        | 10        |
| 80914          | 2" x 10"    | 3.0468        | 10        |
| 80915          | 2" x 11"    | 3.3510        | 10        |
| 80916          | 2" x 12"    | 3.6553        | 10        |

### 2-1/2"

| Black Part No. | Description     | Weight (Lbs.) | Inner Box |
|----------------|-----------------|---------------|-----------|
| 81000          | 2-1/2" x Close  | 1.2081        | 10        |
| 81004          | 2-1/2" x 3"     | 1.4506        | 10        |
| 81005          | 2-1/2" x 3-1/2" | 1.6909        | 10        |
| 81006          | 2-1/2" x 4"     | 1.9335        | 10        |
| 81007          | 2-1/2" x 4-1/2" | 2.1738        | 10        |
| 81008          | 2-1/2" x 5"     | 2.4163        | 10        |
| 81009          | 2-1/2" x 5-1/2" | 2.6566        | 10        |
| 81010          | 2-1/2" x 6"     | 2.8991        | 10        |
| 81011          | 2-1/2" x 7"     | 3.3819        | 10        |
| 81012          | 2-1/2" x 8"     | 3.8647        | 10        |
| 81013          | 2-1/2" x 9"     | 4.3497        | 10        |
| 81014          | 2-1/2" x 10"    | 4.8325        | 5         |
| 81015          | 2-1/2" x 11"    | 5.3153        | 5         |
| 81016          | 2-1/2" x 12"    | 5.7982        | 5         |

**GALVANIZED**  
Seamless & XH Seamless  
Available upon request

**BLACK IRON**  
Schedule 160 & XXH Seamless  
Available upon request

## NIPPLES

## STANDARD SEAMLESS STEEL



## 3"

| Black Part No. | Description | Weight (Lbs.) | Inner Box |
|----------------|-------------|---------------|-----------|
| 81100          | 3" x Close  | 1.6601        | 10        |
| 81104          | 3" x 3"     | 1.8960        | 10        |
| 81105          | 3" x 3-1/2" | 2.2134        | 10        |
| 81106          | 3" x 4"     | 2.5287        | 10        |
| 81107          | 3" x 4-1/2" | 2.8440        | 10        |
| 81108          | 3" x 5"     | 3.1614        | 10        |
| 81109          | 3" x 5-1/2" | 3.4767        | 10        |
| 81110          | 3" x 6"     | 3.7920        | 10        |
| 81111          | 3" x 7"     | 4.4247        | 5         |
| 81112          | 3" x 8"     | 5.0574        | 5         |
| 81113          | 3" x 9"     | 5.6901        | 5         |
| 81114          | 3" x 10"    | 6.3207        | 5         |
| 81115          | 3" x 11"    | 6.9534        | 5         |
| 81116          | 3" x 12"    | 7.5861        | 5         |

## 4"

| Black Part No. | Description | Weight (Lbs.) | Inner Box |
|----------------|-------------|---------------|-----------|
| 81200          | 4" x Close  | 2.5860        | 10        |
| 81205          | 4" x 3-1/2" | 3.1482        | 6         |
| 81206          | 4" x 4"     | 3.6001        | 6         |
| 81208          | 4" x 5"     | 4.4996        | 6         |
| 81209          | 4" x 5-1/2" | 4.9494        | 5         |
| 81210          | 4" x 6"     | 5.3991        | 5         |
| 81211          | 4" x 7"     | 6.2986        | 3         |
| 81212          | 4" x 8"     | 7.1981        | 3         |
| 81213          | 4" x 9"     | 8.0976        | 3         |
| 81214          | 4" x 10"    | 8.9971        | 3         |
| 81215          | 4" x 11"    | 9.8966        | 3         |
| 81216          | 4" x 12"    | 10.7982       | 3         |

## 6"

| Black Part No. | Description | Weight (Lbs.) | Inner Box |
|----------------|-------------|---------------|-----------|
| 81400          | 6" x Close  | 4.9450        | 2         |
| 81406          | 6" x 4"     | 6.3295        | 2         |
| 81407          | 6" x 4-1/2" | 7.1209        | 2         |
| 81408          | 6" x 5"     | 7.9124        | 2         |
| 81409          | 6" x 5-1/2" | 8.7016        | 2         |
| 81410          | 6" x 6"     | 9.4931        | 2         |
| 81411          | 6" x 7"     | 11.0760       | 1         |
| 81412          | 6" x 8"     | 12.6589       | 1         |
| 81413          | 6" x 9"     | 14.2397       | 1         |
| 81414          | 6" x 10"    | 15.8226       | 1         |
| 81415          | 6" x 11"    | 17.4055       | 1         |
| 81416          | 6" x 12"    | 18.9884       | 1         |

**GALVANIZED**  
Seamless & XH Seamless  
Available upon request

**BLACK IRON**  
Schedule 160 & XXH Seamless  
Available upon request

# NIPPLES

# XH SEAMLESS STEEL



## 1/8"

| Black Part No. | Description   | Weight Approx. (Lbs.) | Inner Box | Master Ctn. | Master Wt. (Lbs.) |
|----------------|---------------|-----------------------|-----------|-------------|-------------------|
| 90100          | 1/8" x Close  | 0.0220                | 25        | 100         | 2                 |
| 90101          | 1/8" x 1-1/2" | 0.0397                | 25        | 100         | 4                 |
| 90102          | 1/8" x 2"     | 0.0529                | 25        | 100         | 5                 |
| 90103          | 1/8" x 2-1/2" | 0.0661                | 25        | 100         | 7                 |
| 90104          | 1/8" x 3"     | 0.0794                | 25        | 100         | 8                 |
| 90105          | 1/8" x 3-1/2" | 0.0926                | 25        | 100         | 9                 |
| 90106          | 1/8" x 4"     | 0.1058                | 25        | 100         | 11                |
| 90107          | 1/8" x 4-1/2" | 0.1190                | 25        | 100         | 12                |
| 90108          | 1/8" x 5"     | 0.1323                | 25        | 100         | 13                |
| 90109          | 1/8" x 5-1/2" | 0.1455                | 25        | 100         | 15                |
| 90110          | 1/8" x 6"     | 0.1587                | 25        | 100         | 16                |
| 90111          | 1/8" x 7"     | 0.1852                | 100       | -           | 19                |
| 90112          | 1/8" x 8"     | 0.2094                | 100       | -           | 21                |
| 90113          | 1/8" x 9"     | 0.2359                | 100       | -           | 24                |
| 90114          | 1/8" x 10"    | 0.2624                | 100       | -           | 26                |
| 90115          | 1/8" x 11"    | 0.2888                | 100       | -           | 29                |
| 90116          | 1/8" x 12"    | 0.3153                | 100       | -           | 32                |

## 1/4"

| Black Part No. | Description   | Weight Approx. (Lbs.) | Inner Box | Master Ctn. | Master Wt. (Lbs.) |
|----------------|---------------|-----------------------|-----------|-------------|-------------------|
| 90200          | 1/4" x Close  | 0.0397                | 25        | 100         | 4                 |
| 90201          | 1/4" x 1-1/2" | 0.0661                | 25        | 100         | 7                 |
| 90202          | 1/4" x 2"     | 0.0904                | 25        | 100         | 9                 |
| 90203          | 1/4" x 2-1/2" | 0.1124                | 25        | 100         | 11                |
| 90204          | 1/4" x 3"     | 0.1345                | 25        | 100         | 13                |
| 90205          | 1/4" x 3-1/2" | 0.1565                | 25        | 100         | 16                |
| 90206          | 1/4" x 4"     | 0.1786                | 25        | 100         | 18                |
| 90207          | 1/4" x 4-1/2" | 0.2006                | 25        | 100         | 20                |
| 90208          | 1/4" x 5"     | 0.2249                | 25        | 100         | 22                |
| 90209          | 1/4" x 5-1/2" | 0.2469                | 25        | 100         | 25                |
| 90210          | 1/4" x 6"     | 0.2690                | 25        | 100         | 27                |
| 90211          | 1/4" x 7"     | 0.3131                | 100       | -           | 31                |
| 90212          | 1/4" x 8"     | 0.3594                | 100       | -           | 36                |
| 90213          | 1/4" x 9"     | 0.4034                | 100       | -           | 40                |
| 90214          | 1/4" x 10"    | 0.4475                | 100       | -           | 45                |
| 90215          | 1/4" x 11"    | 0.4916                | 100       | -           | 49                |
| 90216          | 1/4" x 12"    | 0.5379                | 100       | -           | 54                |

## 3/8"

| Black Part No. | Description   | Weight Approx. (Lbs.) | Inner Box | Master Ctn. | Master Wt. (Lbs.) |
|----------------|---------------|-----------------------|-----------|-------------|-------------------|
| 90300          | 3/8" x Close  | 0.0617                | 25        | 100         | 6                 |
| 90301          | 3/8" x 1-1/2" | 0.0926                | 25        | 100         | 9                 |
| 90302          | 3/8" x 2"     | 0.1235                | 25        | 100         | 12                |
| 90303          | 3/8" x 2-1/2" | 0.1543                | 25        | 100         | 15                |
| 90304          | 3/8" x 3"     | 0.1852                | 25        | 100         | 19                |
| 90305          | 3/8" x 3-1/2" | 0.2161                | 25        | 100         | 22                |
| 90306          | 3/8" x 4"     | 0.2469                | 25        | 100         | 25                |
| 90307          | 3/8" x 4-1/2" | 0.2778                | 25        | 100         | 28                |
| 90308          | 3/8" x 5"     | 0.3086                | 25        | 100         | 31                |
| 90309          | 3/8" x 5-1/2" | 0.3395                | 25        | 100         | 34                |
| 90310          | 3/8" x 6"     | 0.3704                | 25        | 100         | 37                |
| 90311          | 3/8" x 7"     | 0.4321                | 75        | -           | 32                |
| 90312          | 3/8" x 8"     | 0.4916                | 75        | -           | 37                |
| 90313          | 3/8" x 9"     | 0.5534                | 75        | -           | 42                |
| 90314          | 3/8" x 10"    | 0.6151                | 75        | -           | 46                |
| 90315          | 3/8" x 11"    | 0.6768                | 75        | -           | 51                |
| 90316          | 3/8" x 12"    | 0.7385                | 75        | -           | 55                |

**GALVANIZED**  
Seamless & XH Seamless  
Available upon request

**BLACK IRON**  
Schedule 160 & XXH Seamless  
Available upon request

TUBE & PIPE

METAL FITTINGS & NIPPLES

PLASTIC FITTINGS

VALVES

FILTER-DRIERS & STRAINERS



## NIPPLES

## XH SEAMLESS STEEL



## 1/2"

| Black Part No. | Description   | Weight (Lbs.) | Inner Box |
|----------------|---------------|---------------|-----------|
| 90400          | 1/2" x Close  | 0.1014        | 25        |
| 90401          | 1/2" x 1-1/2" | 0.1367        | 25        |
| 90402          | 1/2" x 2"     | 0.1808        | 25        |
| 90403          | 1/2" x 2-1/2" | 0.2271        | 25        |
| 90404          | 1/2" x 3"     | 0.2712        | 25        |
| 90405          | 1/2" x 3-1/2" | 0.3175        | 25        |
| 90406          | 1/2" x 4"     | 0.3638        | 25        |
| 90407          | 1/2" x 4-1/2" | 0.4079        | 25        |
| 90408          | 1/2" x 5"     | 0.4542        | 25        |
| 90409          | 1/2" x 5-1/2" | 0.4982        | 25        |
| 90410          | 1/2" x 6"     | 0.5445        | 25        |
| 90411          | 1/2" x 7"     | 0.6349        | 25        |
| 90412          | 1/2" x 8"     | 0.7253        | 25        |
| 90413          | 1/2" x 9"     | 0.8157        | 25        |
| 90414          | 1/2" x 10"    | 0.9061        | 25        |
| 90415          | 1/2" x 11"    | 0.9987        | 25        |
| 90416          | 1/2" x 12"    | 1.0891        | 25        |

## 3/4"

| Black Part No. | Description   | Weight (Lbs.) | Inner Box |
|----------------|---------------|---------------|-----------|
| 90500          | 3/4" x Close  | 0.1698        | 25        |
| 90501          | 3/4" x 1-1/2" | 0.1852        | 25        |
| 90502          | 3/4" x 2"     | 0.2469        | 25        |
| 90503          | 3/4" x 2-1/2" | 0.3086        | 25        |
| 90504          | 3/4" x 3"     | 0.3704        | 25        |
| 90505          | 3/4" x 3-1/2" | 0.4321        | 25        |
| 90506          | 3/4" x 4"     | 0.4916        | 25        |
| 90507          | 3/4" x 4-1/2" | 0.5534        | 25        |
| 90508          | 3/4" x 5"     | 0.6151        | 25        |
| 90509          | 3/4" x 5-1/2" | 0.6768        | 25        |
| 90510          | 3/4" x 6"     | 0.7385        | 25        |
| 90511          | 3/4" x 7"     | 0.8620        | 25        |
| 90512          | 3/4" x 8"     | 0.9855        | 25        |
| 90513          | 3/4" x 9"     | 1.1089        | 25        |
| 90514          | 3/4" x 10"    | 1.2324        | 25        |
| 90515          | 3/4" x 11"    | 1.3558        | 25        |
| 90516          | 3/4" x 12"    | 1.4771        | 25        |

## 1"

| Black Part No. | Description | Weight (Lbs.) | Inner Box |
|----------------|-------------|---------------|-----------|
| 90600          | 1" x Close  | 0.2712        | 25        |
| 90602          | 1" x 2"     | 0.3638        | 25        |
| 90603          | 1" x 2-1/2" | 0.4542        | 25        |
| 90604          | 1" x 3"     | 0.5445        | 25        |
| 90605          | 1" x 3-1/2" | 0.6349        | 25        |
| 90606          | 1" x 4"     | 0.7253        | 25        |
| 90607          | 1" x 4-1/2" | 0.8157        | 25        |
| 90608          | 1" x 5"     | 0.9061        | 25        |
| 90609          | 1" x 5-1/2" | 0.9987        | 25        |
| 90610          | 1" x 6"     | 1.0891        | 25        |
| 90611          | 1" x 7"     | 1.2699        | 25        |
| 90612          | 1" x 8"     | 1.4506        | 25        |
| 90613          | 1" x 9"     | 1.6336        | 25        |
| 90614          | 1" x 10"    | 1.8144        | 25        |
| 90615          | 1" x 11"    | 1.9952        | 25        |
| 90616          | 1" x 12"    | 2.1760        | 25        |

**GALVANIZED**  
Seamless & XH Seamless  
Available upon request

**BLACK IRON**  
Schedule 160 & XXH Seamless  
Available upon request

# NIPPLES

# XH SEAMLESS STEEL



## 1-1/4"

| Black Part No. | Description     | Weight (Lbs.) | Inner Box |
|----------------|-----------------|---------------|-----------|
| 90700          | 1-1/4" x Close  | 0.4057        | 25        |
| 90702          | 1-1/4" x 2"     | 0.5004        | 25        |
| 90703          | 1-1/4" x 2-1/2" | 0.6261        | 25        |
| 90704          | 1-1/4" x 3"     | 0.7518        | 25        |
| 90705          | 1-1/4" x 3-1/2" | 0.8752        | 25        |
| 90706          | 1-1/4" x 4"     | 1.0009        | 25        |
| 90707          | 1-1/4" x 4-1/2" | 1.1266        | 25        |
| 90708          | 1-1/4" x 5"     | 1.2522        | 25        |
| 90709          | 1-1/4" x 5-1/2" | 1.3757        | 25        |
| 90710          | 1-1/4" x 6"     | 1.5013        | 25        |
| 90711          | 1-1/4" x 7"     | 1.7527        | 25        |
| 90712          | 1-1/4" x 8"     | 2.0018        | 25        |
| 90713          | 1-1/4" x 9"     | 2.2531        | 25        |
| 90714          | 1-1/4" x 10"    | 2.5022        | 25        |
| 90715          | 1-1/4" x 11"    | 2.7536        | 10        |
| 90716          | 1-1/4" x 12"    | 3.0027        | 10        |

## 1-1/2"

| Black Part No. | Description     | Weight (Lbs.) | Inner Box |
|----------------|-----------------|---------------|-----------|
| 90800          | 1-1/2" x Close  | 0.5291        | 25        |
| 90802          | 1-1/2" x 2"     | 0.6063        | 25        |
| 90803          | 1-1/2" x 2-1/2" | 0.7562        | 25        |
| 90804          | 1-1/2" x 3"     | 0.9083        | 25        |
| 90805          | 1-1/2" x 3-1/2" | 1.0604        | 25        |
| 90806          | 1-1/2" x 4"     | 1.2125        | 25        |
| 90807          | 1-1/2" x 4-1/2" | 1.3625        | 25        |
| 90808          | 1-1/2" x 5"     | 1.5146        | 25        |
| 90809          | 1-1/2" x 5 1/2" | 1.6667        | 25        |
| 90810          | 1-1/2" x 6"     | 1.8166        | 25        |
| 90811          | 1-1/2" x 7"     | 2.1208        | 10        |
| 90812          | 1-1/2" x 8"     | 2.4229        | 10        |
| 90813          | 1-1/2" x 9"     | 2.7271        | 10        |
| 90814          | 1-1/2" x 10"    | 3.0292        | 10        |
| 90815          | 1-1/2" x 11"    | 3.3312        | 10        |
| 90816          | 1-1/2" x 12"    | 3.6354        | 10        |

## 2"

| Black Part No. | Description | Weight (Lbs.) | Inner Box |
|----------------|-------------|---------------|-----------|
| 90900          | 2" x Close  | 0.8378        | 25        |
| 90903          | 2" x 2-1/2" | 1.0472        | 25        |
| 90904          | 2" x 3"     | 1.2566        | 25        |
| 90905          | 2" x 3-1/2" | 1.4661        | 25        |
| 90906          | 2" x 4"     | 1.6755        | 25        |
| 90907          | 2" x 4-1/2" | 1.8850        | 25        |
| 90908          | 2" x 5"     | 2.0944        | 25        |
| 90909          | 2" x 5-1/2" | 2.3038        | 25        |
| 90910          | 2" x 6"     | 2.5133        | 25        |
| 90911          | 2" x 7"     | 2.9321        | 10        |
| 90912          | 2" x 8"     | 3.3510        | 10        |
| 90913          | 2" x 9"     | 3.7699        | 10        |
| 90914          | 2" x 10"    | 4.1888        | 10        |
| 90915          | 2" x 11"    | 4.6077        | 10        |
| 90916          | 2" x 12"    | 5.0265        | 10        |

**GALVANIZED**  
Seamless & XH Seamless  
Available upon request

**BLACK IRON**  
Schedule 160 & XXH Seamless  
Available upon request

## 2-1/2"

| Black Part No. | Description     | Weight (Lbs.) | Inner Box |
|----------------|-----------------|---------------|-----------|
| 91000          | 2-1/2" x Close  | 1.5961        | 10        |
| 91004          | 2-1/2" x 3"     | 1.9158        | 10        |
| 91005          | 2-1/2" x 3-1/2" | 2.2355        | 10        |

TUBE & PIPE

METAL FITTINGS & NIPPLES

PLASTIC FITTINGS

VALVES

FILTER-DRIERS & STRAINERS



## NIPPLES

## XH SEAMLESS STEEL



## 2-1/2" continued

| Black Part No. | Description     | Weight (Lbs.) | Inner Box |
|----------------|-----------------|---------------|-----------|
| 91006          | 2-1/2" x 4"     | 2.5552        | 10        |
| 91007          | 2-1/2" x 4-1/2" | 2.8748        | 10        |
| 91008          | 2-1/2" x 5"     | 3.1945        | 10        |
| 91009          | 2-1/2" x 5-1/2" | 3.5142        | 10        |
| 91010          | 2-1/2" x 6"     | 3.8338        | 10        |
| 91011          | 2-1/2" x 7"     | 4.4710        | 10        |
| 91012          | 2-1/2" x 8"     | 5.1103        | 10        |
| 91013          | 2-1/2" x 9"     | 5.7497        | 10        |
| 91014          | 2-1/2" x 10"    | 6.3890        | 5         |
| 91015          | 2-1/2" x 11"    | 7.0283        | 5         |
| 91016          | 2-1/2" x 12"    | 7.6655        | 5         |

## 3"

| Black Part No. | Description | Weight (Lbs.) | Inner Box |
|----------------|-------------|---------------|-----------|
| 91100          | 3" x Close  | 2.2443        | 10        |
| 91104          | 3" x 3"     | 2.5640        | 10        |
| 91105          | 3" x 3-1/2" | 2.9917        | 10        |
| 91106          | 3" x 4"     | 3.4194        | 10        |
| 91107          | 3" x 4-1/2" | 3.8471        | 10        |
| 91108          | 3" x 5"     | 4.2748        | 10        |
| 91109          | 3" x 5-1/2" | 4.7025        | 10        |
| 91110          | 3" x 6"     | 5.1302        | 10        |
| 91111          | 3" x 7"     | 5.9856        | 5         |
| 91112          | 3" x 8"     | 6.8387        | 5         |
| 91113          | 3" x 9"     | 7.6941        | 5         |
| 91114          | 3" x 10"    | 8.5495        | 5         |
| 91115          | 3" x 11"    | 9.4049        | 5         |
| 91116          | 3" x 12"    | 10.2603       | 5         |

## 4"

| Black Part No. | Description | Weight (Lbs.) | Inner Box |
|----------------|-------------|---------------|-----------|
| 91200          | 4" x Close  | 3.5935        | 10        |
| 91205          | 4" x 3-1/2" | 4.3740        | 6         |
| 91206          | 4" x 4"     | 4.9979        | 6         |
| 91207          | 4" x 4-1/2" | 5.6240        | 6         |
| 91208          | 4" x 5"     | 6.2479        | 6         |
| 91209          | 4" x 5-1/2" | 6.8740        | 5         |
| 91210          | 4" x 6"     | 7.4979        | 5         |
| 91211          | 4" x 7"     | 8.7479        | 3         |
| 91212          | 4" x 8"     | 9.9980        | 3         |
| 91213          | 4" x 9"     | 11.2480       | 3         |
| 91214          | 4" x 10"    | 12.4980       | 3         |
| 91215          | 4" x 11"    | 13.7458       | 3         |
| 91216          | 4" x 12"    | 14.9958       | 3         |

## 6"

| Black Part No. | Description | Weight (Lbs.) | Inner Box |
|----------------|-------------|---------------|-----------|
| 91400          | 6" x Close  | 7.4472        | 2         |
| 91406          | 6" x 4"     | 9.5328        | 2         |
| 91407          | 6" x 4-1/2" | 10.7233       | 2         |
| 91408          | 6" x 5"     | 11.9138       | 2         |
| 91409          | 6" x 5-1/2" | 13.1065       | 2         |
| 91410          | 6" x 6"     | 14.2970       | 2         |
| 91411          | 6" x 7"     | 16.6802       | 1         |
| 91412          | 6" x 8"     | 19.0634       | 1         |
| 91413          | 6" x 9"     | 21.4466       | 1         |
| 91414          | 6" x 10"    | 23.8298       | 1         |
| 91415          | 6" x 11"    | 26.2130       | 1         |
| 91416          | 6" x 12"    | 28.5962       | 1         |

**GALVANIZED**  
Seamless & XH Seamless  
Available upon request

**BLACK IRON**  
Schedule 160 & XXH Seamless  
Available upon request

# Brass Fittings & Nipples



Mueller's Red and Yellow Brass Fittings and Nipples are carefully produced and threaded to industry specifications to provide a secure and trusted fit. Though these fittings and nipples are used primarily for water in commercial plumbing and OEM applications, they can also be used in oil, gas and steam applications. They are sought after for repair and maintenance because of the durability and resistance to corrosion. All of our red and yellow brass fittings and nipples are 100% inspected and quality tested.

- Class 125lb Red Brass Fittings
- Red Brass Pipe meets ASTM B43-96 standard and ASTM B16.15 Dimensional Specifications
- Red Brass Material specification is to ASTM B62
- Red Brass Fitting and Nipple threads are to specification ANSI B1.20.1



TUBE & PIPE

METAL FITTINGS & NIPPLES

PLASTIC FITTINGS

VALVES

FILTER-DRIERS & STRAINERS

## 90° ELBOW

## RED BRASS



| Part Number | UPC-A (032888) | Size   | Inner/Master Carton Qty. | Master Weight (lbs.) |
|-------------|----------------|--------|--------------------------|----------------------|
| 450-000     | 401009         | 1/8"   | 5/25                     | 38                   |
| 450-001     | 401013         | 1/4"   | 5/25                     | 32                   |
| 450-002     | 401020         | 3/8"   | 5/25                     | 30                   |
| 450-003     | 401037         | 1/2"   | 5/25                     | 46                   |
| 450-004     | 401044         | 3/4"   | 5/25                     | 27                   |
| 550-005     | 401051         | 1"     | 5/25                     | 30                   |
| 450-006     | 401068         | 1-1/4" | 1/50                     | 44                   |
| 550-007     | 401075         | 1-1/2" | 1/35                     | 44                   |
| 450-008     | 401082         | 2"     | 1/20                     | 40                   |

## 90° ELBOW • STREET

## RED BRASS



| Part Number | UPC-A (032888) | Size   | Inner/Master Carton Qty. | Master Weight (lbs.) |
|-------------|----------------|--------|--------------------------|----------------------|
| 452-000     | 401009         | 1/8"   | 5/25                     | 38                   |
| 452-001     | 401013         | 1/4"   | 5/25                     | 32                   |
| 452-002     | 401020         | 3/8"   | 5/25                     | 30                   |
| 452-003     | 401037         | 1/2"   | 5/25                     | 46                   |
| 452-004     | 401044         | 3/4"   | 5/25                     | 27                   |
| 552-005     | 401051         | 1"     | 5/25                     | 30                   |
| 452-006     | 401068         | 1-1/4" | 1/50                     | 44                   |
| 452-007     | 401075         | 1-1/2" | 1/35                     | 44                   |
| 452-008     | 401082         | 2"     | 1/20                     | 40                   |



## 90° ELBOW • REDUCING

## RED BRASS



| Part Number | UPC-A (032888) | Size            | Inner/Master Carton Qty. | Master Weight (lbs.) |
|-------------|----------------|-----------------|--------------------------|----------------------|
| 550-020     | 401105         | 3/8" x 1/8"     | 5/25                     | 29                   |
| 450-021     | 401112         | 3/8" x 1/4"     | 5/25                     | 27                   |
| 450-031     | 401099         | 1/2" x 1/4"     | 5/25                     | 12                   |
| 450-032     | 401129         | 1/2" x 3/8"     | 5/25                     | 17                   |
| 450-041     | 401150         | 3/4" x 1/4"     | 5/25                     | 20                   |
| 450-043     | 401136         | 3/4" x 1/2"     | 5/25                     | 23                   |
| 450-053     | 401167         | 1" x 1/2"       | 5/25                     | 25                   |
| 450-054     | 401143         | 1" x 3/4"       | 5/25                     | 28                   |
| 450-064     | 401174         | 1-1/4" x 3/4"   | 1/40                     | 31                   |
| 450-065     | 401181         | 1-1/4" x 1"     | 1/40                     | 37                   |
| 450-075     | 401198         | 1-1/2" x 1"     | 1/35                     | 34                   |
| 450-076     | 401372         | 1-1/2" x 1-1/4" | 1/35                     | 38                   |
| 450-086     | 401389         | 2" x 1-1/4"     | 1/20                     | 33                   |
| 450-087     | 401396         | 2" x 1-1/2"     | 1/20                     | 40                   |

## 45° ELBOW

## RED BRASS



| Part Number | UPC-A (032888) | Size   | Inner/Master Carton Qty. | Master Weight (lbs.) |
|-------------|----------------|--------|--------------------------|----------------------|
| 451-000     | 401204         | 1/8"   | 5/25                     | 40                   |
| 451-001     | 401211         | 1/4"   | 5/25                     | 30                   |
| 451-002     | 401228         | 3/8"   | 5/25                     | 33                   |
| 451-003     | 401235         | 1/2"   | 5/25                     | 40                   |
| 451-004     | 401242         | 3/4"   | 5/25                     | 24                   |
| 451-005     | 401259         | 1"     | 5/25                     | 28                   |
| 451-006     | 401266         | 1-1/4" | 1/50                     | 35                   |
| 451-007     | 401273         | 1-1/2" | 1/40                     | 42                   |
| 451-008     | 401839         | 2"     | 1/25                     | 39                   |

## 45° ELBOW • STREET

## RED BRASS



| Part Number | UPC-A (032888) | Size   | Inner/Master Carton Qty. | Master Weight (lbs.) |
|-------------|----------------|--------|--------------------------|----------------------|
| 451-100     | 401846         | 1/8"   | 5/25                     | 33                   |
| 451-101     | 401853         | 1/4"   | 5/25                     | 30                   |
| 451-102     | 401860         | 3/8"   | 5/25                     | 23                   |
| 451-103     | 401877         | 1/2"   | 5/25                     | 22                   |
| 451-104     | 401884         | 3/4"   | 5/25                     | 23                   |
| 451-105     | 401891         | 1"     | 5/25                     | 24                   |
| 451-106     | 401990         | 1-1/4" | 1/50                     | 38                   |
| 451-107     | 402195         | 1-1/2" | 1/35                     | 36                   |
| 451-108     | 402560         | 2"     | 1/20                     | 39                   |

## TEE

RED BRASS



| Part Number | UPC-A (032888) | Size   | Inner/Master Carton Qty. | Master Weight (lbs.) |
|-------------|----------------|--------|--------------------------|----------------------|
| 453-000     | 401402         | 1/8"   | 5/25                     | 26                   |
| 453-001     | 401419         | 1/4"   | 5/25                     | 43                   |
| 453-002     | 401426         | 3/8"   | 5/25                     | 43                   |
| 453-003     | 401433         | 1/2"   | 5/25                     | 22                   |
| 453-004     | 401440         | 3/4"   | 5/25                     | 24                   |
| 553-005     | 401457         | 1"     | 5/25                     | 25                   |
| 453-006     | 401464         | 1-1/4" | 1/35                     | 38                   |
| 553-007     | 401471         | 1-1/2" | 1/25                     | 37                   |

## TEE • REDUCING

RED BRASS



| Part Number | UPC-A (032888) | Size          | Inner/Master Carton Qty. | Master Weight (lbs.) |
|-------------|----------------|---------------|--------------------------|----------------------|
| 453-043     | 401495         | 3/4" x 1/2"   | 5/25                     | 32                   |
| 453-053     | 530539         | 1-1/2" x 1/2" | 5/25                     | 40                   |
| 453-054     | 402317         | 1" x 3/4"     | 5/25                     | 32                   |

## CROSS

RED BRASS



| Part Number | UPC-A (032888) | Size   | Inner/Master Carton Qty. | Master Weight (lbs.) |
|-------------|----------------|--------|--------------------------|----------------------|
| 453-100     | 402324         | 1/8"   | 5/25                     | 41                   |
| 453-101     | 402331         | 1/4"   | 5/25                     | 42                   |
| 453-102     | 402348         | 3/8"   | 5/25                     | 25                   |
| 453-103     | 402355         | 1/2"   | 5/25                     | 31                   |
| 453-104     | 402362         | 3/4"   | 5/25                     | 32                   |
| 453-105     | 402379         | 1"     | 5/25                     | 29                   |
| 453-106     | 402386         | 1-1/4" | 1/25                     | 37                   |
| 453-107     | 402393         | 1-1/2" | 1/20                     | 38                   |
| 453-108     | 402515         | 2"     | 1/10                     | 31                   |

## COUPLING

RED BRASS



| Part Number | UPC-A (032888) | Size   | Inner/Master Carton Qty. | Master Weight (lbs.) |
|-------------|----------------|--------|--------------------------|----------------------|
| 454-000     | 401501         | 1/8"   | 5/25                     | 32                   |
| 454-001     | 401518         | 1/4"   | 5/25                     | 48                   |
| 454-002     | 401525         | 3/8"   | 5/25                     | 42                   |
| 454-003     | 401532         | 1/2"   | 5/25                     | 37                   |
| 454-004     | 401549         | 3/4"   | 5/25                     | 21                   |
| 454-005     | 401556         | 1"     | 5/25                     | 33                   |
| 454-006     | 401563         | 1-1/4" | 1/75                     | 46                   |
| 454-007     | 401570         | 1-1/2" | 1/50                     | 40                   |
| 454-008     | 401587         | 2"     | 1/30                     | 37                   |

TUBE & PIPE

METAL FITTINGS & NIPPLES

PLASTIC FITTINGS

VALVES

FILTER-DRIERS & STRAINERS



## COUPLING • REDUCER

RED BRASS



| Part Number | UPC-A (032888) | Size            | Inner/Master Carton Qty. | Master Weight (lbs.) |
|-------------|----------------|-----------------|--------------------------|----------------------|
| 454-010     | 401594         | 1/4" x 1/8"     | 5/25                     | 44                   |
| 454-020     | 401600         | 3/8" x 1/8"     | 5/25                     | 31                   |
| 454-021     | 401617         | 3/8" x 1/4"     | 5/25                     | 31                   |
| 454-031     | 401679         | 1/2" x 1/4"     | 5/25                     | 30                   |
| 454-032     | 401624         | 1/2" x 3/8"     | 5/25                     | 33                   |
| 454-041     | 403543         | 3/4" x 1/4"     | 5/25                     | 14                   |
| 454-042     | 401631         | 3/4" x 3/8"     | 5/25                     | 17                   |
| 454-043     | 401648         | 3/4" x 1/2"     | 5/25                     | 19                   |
| 454-052     | 403550         | 1" x 3/8"       | 5/25                     | 19                   |
| 454-053     | 401655         | 1" x 1/2"       | 5/25                     | 25                   |
| 454-054     | 401662         | 1" x 3/4"       | 5/25                     | 27                   |
| 454-064     | 401686         | 1-1/4" x 3/4"   | 1/90                     | 44                   |
| 454-065     | 401693         | 1-1/4" x 1"     | 1/80                     | 45                   |
| 454-073     | 403567         | 1-1/2" x 1/2"   | 1/75                     | 42                   |
| 454-074     | 403574         | 1-1/2" x 3/4"   | 1/75                     | 45                   |
| 454-075     | 402522         | 1-1/2" x 1"     | 1/65                     | 45                   |
| 454-076     | 402539         | 1-1/2" x 1-1/4" | 1/60                     | 45                   |
| 454-084     | 403581         | 2" x 3/4"       | 1/30                     | 27                   |
| 454-085     | 403598         | 2" x 1"         | 1/30                     | 42                   |
| 454-086     | 402546         | 2" x 1-1/4"     | 1/30                     | 32                   |
| 454-087     | 402553         | 2" x 1-1/2"     | 1/30                     | 32                   |

## BUSHING • HEX

RED BRASS



| Part Number | UPC-A (032888) | Size            | Inner/Master Carton Qty. | Master Weight (lbs.) |
|-------------|----------------|-----------------|--------------------------|----------------------|
| 455-010     | 401709         | 1/4" x 1/8"     | 5/25                     | 24                   |
| 455-020     | 401716         | 3/8" x 1/8"     | 5/25                     | 33                   |
| 455-021     | 401723         | 3/8" x 1/4"     | 5/25                     | 30                   |
| 455-030     | 401792         | 1/2" x 1/8"     | 5/25                     | 29                   |
| 455-031     | 401785         | 1/2" x 1/4"     | 5/25                     | 26                   |
| 455-032     | 401730         | 1/2" x 3/8"     | 5/25                     | 20                   |
| 455-041     | 401822         | 3/4" x 1/4"     | 5/25                     | 33                   |
| 455-042     | 401747         | 3/4" x 3/8"     | 5/25                     | 29                   |
| 455-043     | 401754         | 3/4" x 1/2"     | 5/25                     | 29                   |
| 455-053     | 401761         | 1" x 1/2"       | 5/25                     | 19                   |
| 455-054     | 401778         | 1" x 3/4"       | 5/25                     | 17                   |
| 455-064     | 402577         | 1-1/4" x 3/4"   | 1/120                    | 49                   |
| 455-065     | 402584         | 1-1/4" x 1"     | 1/120                    | 37                   |
| 455-075     | 402591         | 1-1/2" x 1"     | 1/120                    | 67                   |
| 455-076     | 402713         | 1-1/2" x 1-1/4" | 1/120                    | 49                   |
| 455-086     | 402720         | 2" x 1-1/4"     | 1/65                     | 50                   |
| 455-087     | 402737         | 2" x 1-1/2"     | 1/65                     | 49                   |

## LOCKNUT

RED BRASS



| Part Number | UPC-A (032888) | Size | Inner/Master Carton Qty. | Master Weight (lbs.) |
|-------------|----------------|------|--------------------------|----------------------|
| 456-002     | 560024         | 3/8" | 2/25                     | 28                   |
| 456-003     | 402744         | 1/2" | 5/25                     | 28                   |
| 456-004     | 402751         | 3/4" | 5/25                     | 41                   |

**CAP**

**RED BRASS**

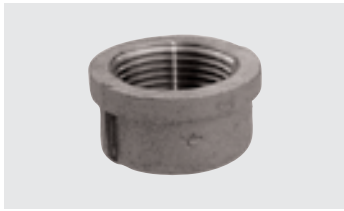

| Part Number | UPC-A (032888) | Size   | Inner/Master Carton Qty. | Master Weight (lbs.) |
|-------------|----------------|--------|--------------------------|----------------------|
| 457-000     | 401907         | 1/8"   | 5/25                     | 27                   |
| 457-001     | 401914         | 1/4"   | 5/25                     | 41                   |
| 457-002     | 401921         | 3/8"   | 5/25                     | 25                   |
| 457-003     | 401938         | 1/2"   | 5/25                     | 36                   |
| 457-004     | 401945         | 3/4"   | 5/25                     | 35                   |
| 557-005     | 401952         | 1"     | 5/25                     | 22                   |
| 457-006     | 401969         | 1-1/4" | 1/100                    | 49                   |
| 557-007     | 401976         | 1-1/2" | 1/100                    | 48                   |
| 457-008     | 401983         | 2"     | 1/70                     | 53                   |

**PLUG • SOLID**

**RED BRASS**



| Part Number | UPC-A (032888) | Size   | Inner/Master Carton Qty. | Master Weight (lbs.) |
|-------------|----------------|--------|--------------------------|----------------------|
| 458-000     | 402003         | 1/8"   | 5/25                     | 14                   |
| 458-001     | 402010         | 1/4"   | 5/25                     | 26                   |
| 458-002     | 402027         | 3/8"   | 5/25                     | 45                   |
| 458-003     | 402034         | 1/2"   | 5/25                     | 42                   |
| 458-004     | 402041         | 3/4"   | 5/25                     | 46                   |
| 558-005     | 402058         | 1"     | 5/25                     | 28                   |
| 458-006     | 402065         | 1-1/4" | 5/140                    | 85                   |
| 558-007     | 402072         | 1-1/2" | 5/120                    | 97                   |
| 458-008     | 402089         | 2"     | 5/100                    | 146                  |

**PLUG • CORED**

**RED BRASS**



| Part Number | UPC-A (032888) | Size   | Inner/Master Carton Qty. | Master Weight (lbs.) |
|-------------|----------------|--------|--------------------------|----------------------|
| 458-093     | 402096         | 1/2"   | 5/25                     | 33                   |
| 458-094     | 402768         | 3/4"   | 5/25                     | 32                   |
| 458-095     | 402775         | 1"     | 5/25                     | 17                   |
| 458-096     | 402782         | 1-1/4" | 5/140                    | 43                   |
| 458-097     | 402799         | 1-1/2" | 1/120                    | 49                   |
| 458-098     | 402911         | 2"     | 1/100                    | 71                   |

**UNION**

**RED BRASS**



| Part Number | UPC-A (032888) | Size   | Inner/Master Carton Qty. | Master Weight (lbs.) |
|-------------|----------------|--------|--------------------------|----------------------|
| 459-000     | 402102         | 1/8"   | 5/25                     | 29                   |
| 459-001     | 402119         | 1/4"   | 5/25                     | 25                   |
| 459-002     | 402126         | 3/8"   | 5/25                     | 29                   |
| 459-003     | 402133         | 1/2"   | 5/25                     | 32                   |
| 459-004     | 402140         | 3/4"   | 5/25                     | 32                   |
| 559-005     | 402157         | 1"     | 5/25                     | 25                   |
| 459-006     | 402164         | 1-1/4" | 1/35                     | 43                   |
| 559-007     | 402171         | 1-1/2" | 1/25                     | 42                   |
| 459-008     | 402188         | 2"     | 1/15                     | 36                   |

TUBE & PIPE

METAL FITTINGS & NIPPLES

PLASTIC FITTINGS

VALVES

FILTER-DRIERS & STRAINERS



**1/8" NIPPLE****RED BRASS**

| Part Number | UPC-A (032888) | Size          | Inner/Master Carton Qty. | Master Weight (lbs.) |
|-------------|----------------|---------------|--------------------------|----------------------|
| 460-001     | 402201         | 1/8" x Close  | 5/25                     | 1                    |
| 460-015     | 402218         | 1/8" x 1-1/2" | 5/25                     | 1                    |
| 460-020     | 402225         | 1/8" x 2"     | 5/25                     | 1                    |
| 460-025     | 402232         | 1/8" x 2-1/2" | 5/25                     | 1                    |
| 460-030     | 402249         | 1/8" x 3"     | 5/25                     | 2                    |
| 460-035     | 402256         | 1/8" x 3-1/2" | 5/25                     | 2                    |
| 460-040     | 402263         | 1/8" x 4"     | 5/25                     | 2                    |
| 460-045     | 402270         | 1/8" x 4-1/2" | 5/25                     | 2                    |
| 460-050     | 402287         | 1/8" x 5"     | 5/25                     | 3                    |
| 460-055     | 402294         | 1/8" x 5-1/2" | 5/25                     | 3                    |
| 460-060     | 402300         | 1/8" x 6"     | 5/25                     | 3                    |

**1/4" NIPPLE****RED BRASS**

| Part Number | UPC-A (032888) | Size          | Inner/Master Carton Qty. | Master Weight (lbs.) |
|-------------|----------------|---------------|--------------------------|----------------------|
| 461-001     | 402409         | 1/4" x Close  | 5/25                     | 1                    |
| 461-015     | 402416         | 1/4" x 1-1/2" | 5/25                     | 2                    |
| 461-020     | 402423         | 1/4" x 2"     | 5/25                     | 2                    |
| 461-025     | 402430         | 1/4" x 2-1/2" | 5/25                     | 2                    |
| 461-030     | 402447         | 1/4" x 3"     | 5/25                     | 3                    |
| 461-035     | 402454         | 1/4" x 3-1/2" | 5/25                     | 3                    |
| 461-040     | 402461         | 1/4" x 4"     | 5/25                     | 4                    |
| 461-045     | 402478         | 1/4" x 4-1/2" | 5/25                     | 4                    |
| 461-050     | 402485         | 1/4" x 5"     | 5/25                     | 5                    |
| 461-055     | 402492         | 1/4" x 5-1/2" | 5/25                     | 5                    |
| 461-060     | 402508         | 1/4" x 6"     | 5/25                     | 5                    |

**3/8" NIPPLE****RED BRASS**

| Part Number | UPC-A (032888) | Size          | Inner/Master Carton Qty. | Master Weight (lbs.) |
|-------------|----------------|---------------|--------------------------|----------------------|
| 462-001     | 402607         | 3/8" x Close  | 5/25                     | 1                    |
| 462-015     | 402614         | 3/8" x 1-1/2" | 5/25                     | 2                    |
| 462-020     | 402621         | 3/8" x 2"     | 5/25                     | 3                    |
| 462-025     | 402638         | 3/8" x 2-1/2" | 5/25                     | 3                    |
| 462-030     | 402645         | 3/8" x 3"     | 5/25                     | 4                    |
| 462-035     | 402652         | 3/8" x 3-1/2" | 5/25                     | 4                    |
| 462-040     | 402669         | 3/8" x 4"     | 5/25                     | 5                    |
| 462-045     | 402676         | 3/8" x 4-1/2" | 5/25                     | 6                    |
| 462-050     | 402683         | 3/8" x 5"     | 5/25                     | 6                    |
| 462-055     | 402690         | 3/8" x 5-1/2" | 5/25                     | 6                    |
| 462-060     | 402706         | 3/8" x 6"     | 5/25                     | 8                    |
| 462-080     | 403420         | 3/8" x 8"     | 5/25                     | 10                   |
| 462-120     | 403437         | 3/8" x 12"    | 5/25                     | 16                   |

## 1/2" NIPPLE

## RED BRASS

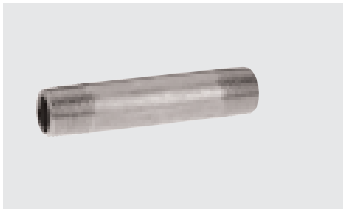

| Part Number | UPC-A (032888) | Size          | Inner/Master Carton Qty. | Master Weight (lbs.) |
|-------------|----------------|---------------|--------------------------|----------------------|
| 463-001     | 402805         | 1/2" x Close  | 5/25                     | 2                    |
| 463-015     | 402812         | 1/2" x 1-1/2" | 5/25                     | 3                    |
| 463-020     | 402829         | 1/2" x 2"     | 5/25                     | 3                    |
| 463-025     | 402836         | 1/2" x 2-1/2" | 5/25                     | 4                    |
| 463-030     | 402843         | 1/2" x 3"     | 5/25                     | 5                    |
| 463-035     | 402850         | 1/2" x 3-1/2" | 5/25                     | 6                    |
| 463-040     | 402867         | 1/2" x 4"     | 5/25                     | 7                    |
| 463-045     | 402874         | 1/2" x 4-1/2" | 5/25                     | 8                    |
| 463-050     | 402881         | 1/2" x 5"     | 5/25                     | 9                    |
| 463-055     | 402898         | 1/2" x 5-1/2" | 5/25                     | 10                   |
| 463-060     | 402904         | 1/2" x 6"     | 5/25                     | 11                   |
| 463-080     | 403444         | 1/2" x 8"     | 5/25                     | 15                   |
| 463-100     | 403451         | 1/2" x 10"    | 5/25                     | 19                   |
| 463-120     | 403000         | 1/2" x 12"    | 5/25                     | 24                   |

## 3/4" NIPPLE

## RED BRASS

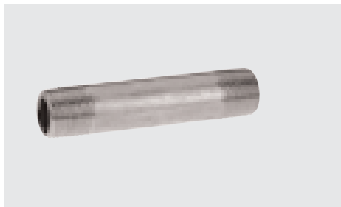

| Part Number | UPC-A (032888) | Size          | Inner/Master Carton Qty. | Master Weight (lbs.) |
|-------------|----------------|---------------|--------------------------|----------------------|
| 464-001     | 403000         | 3/4" x Close  | 5/25                     | 3                    |
| 464-015     | 403109         | 3/4" x 1-1/2" | 5/25                     | 4                    |
| 464-020     | 403017         | 3/4" x 2"     | 5/25                     | 5                    |
| 464-025     | 403024         | 3/4" x 2-1/2" | 5/25                     | 6                    |
| 464-030     | 403031         | 3/4" x 3"     | 5/25                     | 7                    |
| 464-035     | 403048         | 3/4" x 3-1/2" | 5/25                     | 9                    |
| 464-040     | 403055         | 3/4" x 4"     | 5/25                     | 10                   |
| 464-045     | 403062         | 3/4" x 4-1/2" | 5/25                     | 11                   |
| 464-050     | 403079         | 3/4" x 5"     | 5/25                     | 13                   |
| 464-055     | 403086         | 3/4" x 5-1/2" | 5/25                     | 14                   |
| 464-060     | 403093         | 3/4" x 6"     | 5/25                     | 16                   |
| 464-080     | 403475         | 3/4" x 8"     | 5/25                     | 21                   |
| 464-100     | 403482         | 3/4" x 10"    | 5/10                     | 11                   |
| 464-120     | 403499         | 3/4" x 12"    | 5/25                     | 32                   |

## 1" NIPPLE

## RED BRASS

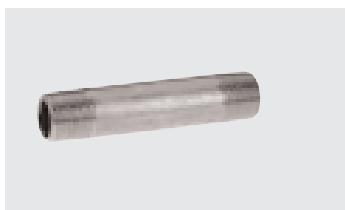

| Part Number | UPC-A (032888) | Size        | Inner/Master Carton Qty. | Master Weight (lbs.) |
|-------------|----------------|-------------|--------------------------|----------------------|
| 465-001     | 403208         | 1" x Close  | 5/25                     | 4                    |
| 465-020     | 403215         | 1" x 2"     | 5/25                     | 6                    |
| 465-025     | 403222         | 1" x 2-1/2" | 5/25                     | 8                    |
| 465-030     | 403239         | 1" x 3"     | 5/25                     | 10                   |
| 465-035     | 403246         | 1" x 3-1/2" | 5/25                     | 12                   |
| 465-040     | 403253         | 1" x 4"     | 5/25                     | 13                   |
| 465-045     | 403260         | 1" x 4-1/2" | 5/25                     | 15                   |
| 465-050     | 403277         | 1" x 5"     | 5/25                     | 17                   |
| 465-055     | 403284         | 1" x 5-1/2" | 5/25                     | 19                   |
| 465-060     | 403291         | 1" x 6"     | 5/25                     | 21                   |
| 465-080     | 403505         | 1" x 8"     | 5/25                     | 28                   |
| 465-100     | 403512         | 1" x 10"    | 5/25                     | 37                   |
| 465-120     | 403529         | 1" x 12"    | 5/10                     | 43                   |

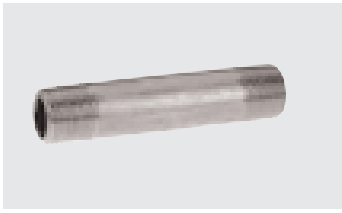
**1-1/4" NIPPLE****RED BRASS**

| Part Number | UPC-A (032888) | Size            | Inner/Master Carton Qty. | Master Weight (lbs.) |
|-------------|----------------|-----------------|--------------------------|----------------------|
| 466-001     | 402928         | 1-1/4" x Close  | 5/10                     | 3                    |
| 466-020     | 402935         | 1-1/4" x 2"     | 5/10                     | 4                    |
| 466-025     | 402942         | 1-1/4" x 2-1/2" | 5/25                     | 12                   |
| 466-030     | 402959         | 1-1/4" x 3"     | 5/10                     | 6                    |
| 466-035     | 402966         | 1-1/4" x 3-1/2" | 5/10                     | 7                    |
| 466-040     | 402973         | 1-1/4" x 4"     | 5/10                     | 8                    |
| 466-045     | 402980         | 1-1/4" x 4-1/2" | 5/10                     | 9                    |
| 466-050     | 402997         | 1-1/4" x 5"     | 5/10                     | 10                   |
| 466-055     | 403116         | 1-1/4" x 5-1/2" | 5/25                     | 28                   |
| 466-060     | 403123         | 1-1/4" x 6"     | 5/10                     | 13                   |

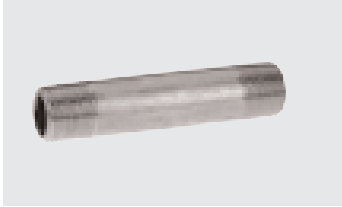
**1-1/2" NIPPLE****RED BRASS**

| Part Number | UPC-A (032888) | Size            | Inner/Master Carton Qty. | Master Weight (lbs.) |
|-------------|----------------|-----------------|--------------------------|----------------------|
| 467-001     | 403130         | 1-1/2" x Close  | 5/10                     | 4                    |
| 467-020     | 403147         | 1-1/2" x 2"     | 5/10                     | 5                    |
| 467-025     | 403154         | 1-1/2" x 2-1/2" | 5/10                     | 6                    |
| 467-030     | 403161         | 1-1/2" x 3"     | 5/10                     | 7                    |
| 467-035     | 403178         | 1-1/2" x 3-1/2" | 5/10                     | 8                    |
| 467-040     | 403185         | 1-1/2" x 4"     | 5/10                     | 10                   |
| 467-045     | 403192         | 1-1/2" x 4-1/2" | 5/10                     | 12                   |
| 467-050     | 403307         | 1-1/2" x 5"     | 5/10                     | 12                   |
| 467-055     | 403314         | 1-1/2" x 5-1/2" | 5/10                     | 14                   |
| 467-060     | 403321         | 1-1/2" x 6"     | 5/10                     | 15                   |

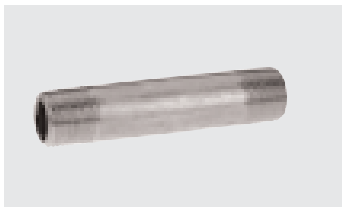
**2" NIPPLE****RED BRASS**

| Part Number | UPC-A (032888) | Size        | Inner/Master Carton Qty. | Master Weight (lbs.) |
|-------------|----------------|-------------|--------------------------|----------------------|
| 468-001     | 403338         | 2" x Close  | 5/10                     | 6                    |
| 468-025     | 403345         | 2" x 2-1/2" | 5/10                     | 8                    |
| 468-030     | 403352         | 2" x 3"     | 5/10                     | 10                   |
| 468-035     | 403369         | 2" x 3-1/2" | 5/10                     | 11                   |
| 468-040     | 403376         | 2" x 4"     | 5/10                     | 13                   |
| 468-045     | 403383         | 2" x 4-1/2" | 5/10                     | 14                   |
| 468-050     | 403390         | 2" x 5"     | 5/10                     | 16                   |
| 468-055     | 403406         | 2" x 5-1/2" | 5/25                     | 44                   |
| 468-060     | 403413         | 2" x 6"     | 5/10                     | 20                   |

**90° ELBOW**

**YELLOW BRASS**



| Part Number | UPC-A (032888) | Size | Inner/Master Carton Qty. | Master Weight (lbs.) |
|-------------|----------------|------|--------------------------|----------------------|
| 470-000     | 700000         | 1/8" | 5/25                     | 2                    |
| 470-001     | 700017         | 1/4" | 5/25                     | 3                    |
| 470-002     | 700024         | 3/8" | 5/25                     | 5                    |

**90° ELBOW • STREET**

**YELLOW BRASS**



| Part Number | UPC-A (032888) | Size | Inner/Master Carton Qty. | Master Weight (lbs.) |
|-------------|----------------|------|--------------------------|----------------------|
| 472-000     | 720008         | 1/8" | 5/25                     | 1                    |
| 472-001     | 720015         | 1/4" | 5/25                     | 2                    |
| 472-002     | 720022         | 3/8" | 5/25                     | 4                    |

**45° ELBOW**

**YELLOW BRASS**

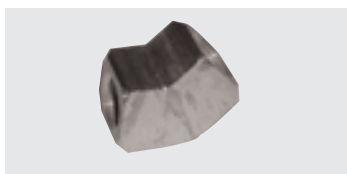

| Part Number | UPC-A (032888) | Size | Inner/Master Carton Qty. | Master Weight (lbs.) |
|-------------|----------------|------|--------------------------|----------------------|
| 471-000     | 710009         | 1/8" | 5/25                     | 2                    |
| 471-001     | 710016         | 1/4" | 5/25                     | 3                    |

**45° ELBOW • STREET**

**YELLOW BRASS**

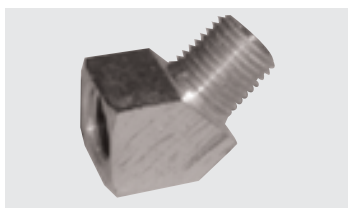

| Part Number | UPC-A (032888) | Size | Inner/Master Carton Qty. | Master Weight (lbs.) |
|-------------|----------------|------|--------------------------|----------------------|
| 471-100     | 711006         | 1/8" | 5/25                     | 1                    |
| 471-101     | 711013         | 1/4" | 5/25                     | 2                    |

**TEE**

**YELLOW BRASS**

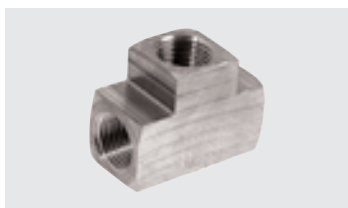

| Part Number | UPC-A (032888) | Size | Inner/Master Carton Qty. | Master Weight (lbs.) |
|-------------|----------------|------|--------------------------|----------------------|
| 473-000     | 730007         | 1/8" | 5/25                     | 3                    |
| 473-001     | 730014         | 1/4" | 5/25                     | 4                    |
| 473-002     | 730021         | 3/8" | 5/25                     | 6                    |



## COUPLING

## YELLOW BRASS



| Part Number | UPC-A (032888) | Size | Inner/Master Carton Qty. | Master Weight (lbs.) |
|-------------|----------------|------|--------------------------|----------------------|
| 474-000     | 740006         | 1/8" | 5/25                     | 1                    |
| 474-001     | 740013         | 1/4" | 5/25                     | 1                    |
| 474-002     | 740020         | 3/8" | 5/25                     | 2                    |

## BUSHING • HEX

## YELLOW BRASS



| Part Number | UPC-A (032888) | Size        | Inner/Master Carton Qty. | Master Weight (lbs.) |
|-------------|----------------|-------------|--------------------------|----------------------|
| 475-010     | 750140         | 1/4" x 1/8" | 5/25                     | 1                    |
| 575-020     | 750203         | 3/8" x 1/8" | 5/25                     | 2                    |
| 475-021     | 750210         | 3/8" x 1/4" | 5/25                     | 2                    |
| 575-030     | 750302         | 1/2" x 1/8" | 5/25                     | 3                    |
| 475-031     | 750319         | 1/2" x 1/4" | 5/25                     | 3                    |
| 475-032     | 750326         | 1/2" x 3/8" | 5/25                     | 2                    |

## BUSHING • FACE

## YELLOW BRASS



| Part Number | UPC-A (032888) | Size        | Inner/Master Carton Qty. | Master Weight (lbs.) |
|-------------|----------------|-------------|--------------------------|----------------------|
| 456-032     | 401808         | 1/2" x 3/8" | 5/25                     | 1                    |
| 456-043     | 401815         | 3/4" x 1/2" | 5/25                     | 2                    |

## CAP

## YELLOW BRASS



| Part Number | UPC-A (032888) | Size | Inner/Master Carton Qty. | Master Weight (lbs.) |
|-------------|----------------|------|--------------------------|----------------------|
| 476-000     | 760004         | 1/8" | 5/25                     | 1                    |
| 476-001     | 760011         | 1/4" | 5/25                     | 2                    |
| 476-002     | 760028         | 3/8" | 5/25                     | 2                    |

## PLUG SOLID

## YELLOW BRASS



| Part Number | UPC-A (032888) | Size | Inner/Master Carton Qty. | Master Weight (lbs.) |
|-------------|----------------|------|--------------------------|----------------------|
| 478-000     | 780002         | 1/8" | 5/25                     | 1                    |
| 478-001     | 780019         | 1/4" | 5/25                     | 2                    |
| 478-002     | 780026         | 3/8" | 5/25                     | 2                    |

**1/8" NIPPLE****YELLOW BRASS**

| Part Number | UPC-A (032888) | Size          | Inner/Master Carton Qty. | Master Weight (lbs.) |
|-------------|----------------|---------------|--------------------------|----------------------|
| 480-001     | 800014         | 1/8" x Close  | 5/25                     | 1                    |
| 480-015     | 800151         | 1/8" x 1-1/2" | 5/25                     | 1                    |
| 480-020     | 800205         | 1/8" x 2"     | 5/25                     | 1                    |

**1/4" NIPPLE****YELLOW BRASS**

| Part Number | UPC-A (032888) | Size         | Inner/Master Carton Qty. | Master Weight (lbs.) |
|-------------|----------------|--------------|--------------------------|----------------------|
| 481-001     | 810013         | 1/4" x Close | 5/25                     | 1                    |
| 481-020     | 810204         | 1/4" x 2"    | 5/25                     | 2                    |

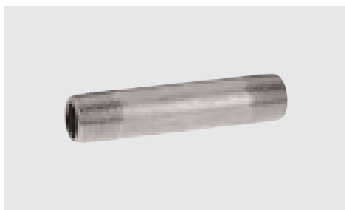
**3/8" NIPPLE****YELLOW BRASS**

| Part Number | UPC-A (032888) | Size          | Inner/Master Carton Qty. | Master Weight (lbs.) |
|-------------|----------------|---------------|--------------------------|----------------------|
| 482-001     | 820012         | 3/8" x Close  | 5/25                     | 1                    |
| 482-015     | 820159         | 3/8" x 1-1/2" | 5/25                     | 2                    |
| 482-010     | 820203         | 3/8" x 2"     | 5/25                     | 5                    |

TUBE &amp; PIPE

METAL FITTINGS &amp; NIPPLES

PLASTIC FITTINGS

VALVES

FILTER-DRIERS &amp; STRAINERS



# Brass Flare Fittings & Flanges



Complementary to a wide range of air conditioning and refrigeration components, Mueller provides brass flare fittings machined to assure tight leak proof joints. Manufactured since the 1920s, Mueller offers a complete range of universal fittings to meet industry requirements and standards. Choose a Mueller brass fitting and be confident of its performance quality ensuring unrestricted flow and reduced pressure drop.

PostScriptPicture

## 45° FLARE FITTINGS

## BRASS

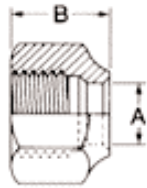

| SHORT FORGED NUTS* |          |         |      |        |      |      |        |          |         |
|--------------------|----------|---------|------|--------|------|------|--------|----------|---------|
| Cat. No.           | Part No. | F Flare | Size |        | A    |      | B      | Pcs.     |         |
|                    |          |         | Tube | Hex    | Min. | Max. |        | Per Ctn. | Wt./Ea. |
| NS4-3              | A 05238  | 3/16    | 3/16 | 1/2    | .192 | .197 | 17/32  | 50       | .02     |
| NS4-4              | A 05051  | 1/4     | 1/4  | 5/8    | .255 | .260 | 19/32  | 50       | .04     |
| NS4-5              | A 05239  | 5/16    | 5/16 | 1 1/16 | .317 | .320 | 5/8    | 25       | .04     |
| NS4-6              | A 05052  | 3/8     | 3/8  | 1 3/16 | .380 | .385 | 1 1/16 | 25       | .06     |
| NS4-8              | A 05053  | 1/2     | 1/2  | 1 5/16 | .505 | .510 | 1 3/16 | 15       | .08     |
| NS4-10             | A 05157  | 5/8     | 5/8  | 1-1/16 | .630 | .635 | 1 5/16 | 10       | .12     |
| NS4-12             | A 05222  | 3/4     | 3/4  | 1-5/16 | .755 | .760 | 1-1/8  | 10       | .24     |

\*Recognized under the component program of Underwriters Laboratories.

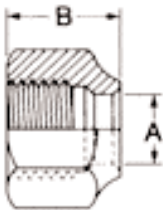
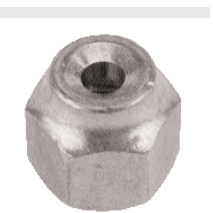

| SHORT FORGED REDUCING NUTS* |          |         |      |        |      |      |        |          |         |
|-----------------------------|----------|---------|------|--------|------|------|--------|----------|---------|
| Cat. No.                    | Part No. | F Flare | Size |        | A    |      | B      | Pcs.     |         |
|                             |          |         | Tube | Hex    | Min. | Max. |        | Per Ctn. | Wt./Ea. |
| NRS4-43                     | A 05132  | 1/4     | 3/16 | 5/8    | .192 | .197 | 19/32  | 10       | .04     |
| NRS4-54                     | A 05247  | 5/16    | 1/4  | 1 1/16 | .255 | .260 | 5/8    | 10       | .04     |
| NRS4-64                     | A 05140  | 3/8     | 1/4  | 1 3/16 | .255 | .260 | 1 1/16 | 25       | .06     |
| NRS4-65                     | A 05282  | 3/8     | 5/16 | 1 3/16 | .320 | .325 | 1 1/16 | 10       | .06     |
| NRS4-86                     | A 05141  | 1/2     | 3/8  | 1 5/16 | .380 | .385 | 1 3/16 | 15       | .10     |
| NRS4-108                    | A 05228  | 5/8     | 1/2  | 1-1/16 | .505 | .510 | 1 5/16 | 15       | .13     |

\*Recognized under the component program of Underwriters Laboratories.

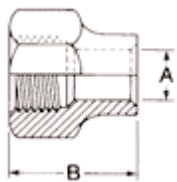

| LONG FORGED NUTS* |          |         |      |        |      |      |        |          |         |
|-------------------|----------|---------|------|--------|------|------|--------|----------|---------|
| Cat. No.          | Part No. | F Flare | Size |        | A    |      | B      | Pcs.     |         |
|                   |          |         | Tube | Hex    | Min. | Max. |        | Per Ctn. | Wt./Ea. |
| N4-4              | A 00440  | 1/4     | 1/4  | 5/8    | .255 | .260 | 1 5/16 | 25       | .06     |
| N4-5              | A 01110  | 5/16    | 5/16 | 1 1/16 | .317 | .322 | 1 5/16 | 25       | .05     |
| N4-6              | A 00441  | 3/8     | 3/8  | 1 3/16 | .380 | .385 | 1-1/16 | 25       | .08     |
| N4-8              | A 00442  | 1/2     | 1/2  | 1 5/16 | .505 | .510 | 1-3/16 | 10       | .13     |
| N4-10             | A 01112  | 5/8     | 5/8  | 1-1/16 | .630 | .635 | 1-7/16 | 5        | .19     |
| N4-12             | A 04731  | 3/4     | 3/4  | 1-5/16 | .755 | .760 | 1-3/4  | 5        | .36     |

\*Recognized under the component program of Underwriters Laboratories.



# 45° FLARE FITTINGS

**BRASS**

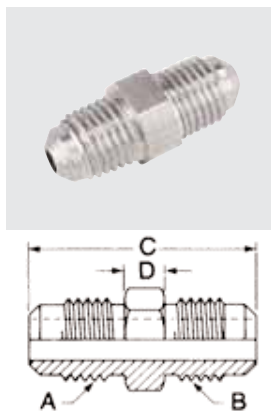
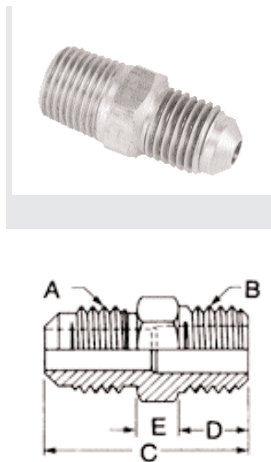
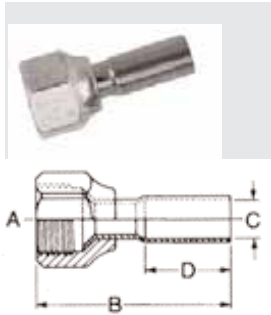

## INTERNAL FLARE TO EXTENSION SOLDER

| Cat. No. | Part No. | A   | B       | C   | D     | Pcs. Per Ctn. | Wt./Ea. |
|----------|----------|-----|---------|-----|-------|---------------|---------|
| US5-44   | A 15725  | 1/4 | 1-5/8   | 1/4 | 13/16 | 25            | .042    |
| US5-66   | A 15726  | 3/8 | 1-11/16 | 3/8 | 13/16 | 25            | .061    |
| US5-88   | A 15727  | 1/2 | 1-15/16 | 1/2 | 7/8   | 20            | .104    |
| US5-1010 | A 15728  | 5/8 | 2-5/16  | 5/8 | 1     | 10            | .161    |
| US5-1212 | A 15729  | 3/4 | 2-7/8   | 3/4 | 1-1/4 | 10            | .218    |

Recognized under the component program of Underwriters Laboratories.

## CONNECTORS, HALF UNION – FLARE TO NPTFE

| Cat. No. | Part No. | Size    |         | C       | D    | E    | Size Hex | Pcs. Per Ctn. | Wt./Ea. |
|----------|----------|---------|---------|---------|------|------|----------|---------------|---------|
|          |          | Flare A | NPTFE B |         |      |      |          |               |         |
| UI-3A    | A 01117  | 3/16    | 1/8     | 1       | 3/8  | 3/16 | 7/16     | 15            | .03     |
| UI-4A    | A 00330  | 1/4     | 1/8     | 1-1/16  | 3/8  | 3/16 | 7/16     | 25            | .03     |
| UI-4B    | A 04585  | 1/4     | 1/4     | 1-1/4   | 9/16 | 3/16 | 9/16     | 25            | .05     |
| UI-4C    | A 01197  | 1/4     | 3/8     | 1-5/16  | 9/16 | 1/4  | 11/16    | 25            | .07     |
| UI-4D    | A 04628  | 1/4     | 1/2     | 1-9/16  | 3/4  | 5/16 | 7/8      | 25            | .11     |
| UI-5A    | A 00331  | 5/16    | 1/8     | 1-5/32  | 3/8  | 5/16 | 1/2      | 25            | .04     |
| UI-5B    | A 05036  | 5/16    | 1/4     | 1-11/32 | 9/16 | 7/32 | 9/16     | 25            | .06     |
| UI-5C    | A 01198  | 5/16    | 3/8     | 1-3/8   | 9/16 | 1/4  | 11/16    | 25            | .08     |
| UI-6A    | A 05003  | 3/8     | 1/8     | 1-1/4   | 3/8  | 1/4  | 5/8      | 25            | .07     |
| UI-6B    | A 00332  | 3/8     | 1/4     | 1-7/16  | 9/16 | 1/4  | 5/8      | 25            | .08     |
| UI-6C    | A 01199  | 3/8     | 3/8     | 1-7/16  | 9/16 | 1/4  | 11/16    | 25            | .09     |
| UI-6D    | A 04993  | 3/8     | 1/2     | 1-11/16 | 3/4  | 5/16 | 7/8      | 25            | .14     |
| UI-8A    | A 05034  | 1/2     | 1/8     | 1 7/16  | 3/8  | 5/16 | 3/4      | 10            | .10     |
| UI-8B    | A 04439  | 1/2     | 1/4     | 1-5/8   | 9/16 | 5/16 | 3/4      | 10            | .11     |
| UI-8C    | A 00334  | 1/2     | 3/8     | 1-5/8   | 9/16 | 5/16 | 3/4      | 10            | .11     |
| UI-8D    | A 04780  | 1/2     | 1/2     | 1-13/16 | 3/4  | 5/16 | 7/8      | 10            | .15     |
| UI-8E    | A 05066  | 1/2     | 3/4     | 1-15/16 | 3/4  | 7/16 | 1-1/16   | 10            | .21     |
| UI-10B   | A 05035  | 5/8     | 1/4     | 1-13/16 | 9/16 | 3/8  | 7/8      | 10            | .16     |
| UI-10C   | A 01195  | 5/8     | 3/8     | 1-13/16 | 9/16 | 3/8  | 7/8      | 10            | .17     |
| UI-10D   | A 04540  | 5/8     | 1/2     | 2       | 3/4  | 3/8  | 7/8      | 10            | .18     |
| UI-10E   | A 04827  | 5/8     | 3/4     | 2-1/16  | 3/4  | 7/16 | 1-1/16   | 5             | .24     |
| UI-12C   | A 05005  | 3/4     | 3/8     | 2       | 9/16 | 7/16 | 1-1/16   | 25            | .27     |
| UI-12D   | A 04739  | 3/4     | 1/2     | 2-3/16  | 3/4  | 7/16 | 1-1/16   | 5             | .25     |
| UI-12E   | A 04740  | 3/4     | 3/4     | 2-3/16  | 3/4  | 7/16 | 1-1/16   | 5             | .33     |

## UNION – FLARE TO FLARE

| Cat. No. | Part No. | Size    |         | C       | D    | Size Hex | Pcs. Per Ctn. | Wt./Ea. |
|----------|----------|---------|---------|---------|------|----------|---------------|---------|
|          |          | Flare A | Flare B |         |      |          |               |         |
| U2-3     | A 04621  | 3/16    | 3/16    | 1-1/16  | 3/16 | 3/8      | 25            | .03     |
| U2-4     | A 00325  | 1/4     | 1/4     | 1-3/16  | 3/16 | 7/16     | 25            | .04     |
| U2-5     | A 00326  | 5/16    | 5/16    | 1-11/32 | 7/32 | 1/2      | 25            | .06     |
| U2-6     | A 00327  | 3/8     | 3/8     | 1-1/2   | 1/4  | 5/8      | 25            | .09     |
| U2-8     | A 00329  | 1/2     | 1/2     | 1-13/16 | 5/16 | 3/4      | 15            | .15     |
| U2-10    | A 04845  | 5/8     | 5/8     | 2-1/8   | 3/8  | 7/8      | 10            | .22     |
| U2-12    | A 04733  | 3/4     | 3/4     | 2-7/16  | 7/16 | 11/16    | 10            | .37     |

TUBE & PIPE

METAL FITTINGS & NIPPLES

PLASTIC FITTINGS

VALVES

FILTER-DRYERS & STRAINERS



## 45° FLARE FITTINGS

BRASS

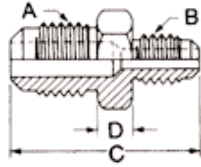

## REDUCING UNION – FLARE TO FLARE

| Cat. No. | Part No. | Size    |         |         | Size Hex | Pcs. Per Ctn. | Wt./Ea. |     |
|----------|----------|---------|---------|---------|----------|---------------|---------|-----|
|          |          | Flare A | Flare B | C       |          |               |         |     |
| UR2-43   | A 05270  | 1/4     | 3/16    | 1-1/8   | 3/16     | 7/16          | 15      | .03 |
| UR2-54   | A 08730  | 5/16    | 1/4     | 1-9/32  | 7/32     | 1/2           | 10      | .05 |
| UR2-64   | A 01171  | 3/8     | 1/4     | 1-3/8   | 1/4      | 5/8           | 15      | .07 |
| UR2-65   | A 04981  | 3/8     | 5/16    | 1-7/16  | 1/4      | 5/8           | 10      | .08 |
| UR2-84   | A 00356  | 1/2     | 1/4     | 1-9/16  | 5/16     | 3/4           | 15      | .12 |
| UR2-86   | A 00149  | 1/2     | 3/8     | 1-11/16 | 5/16     | 3/4           | 25      | .14 |
| UR2-106  | A 05334  | 5/8     | 3/8     | 1-7/8   | 3/8      | 7/8           | 10      | .18 |
| UR2-108  | A 04846  | 5/8     | 1/2     | 2       | 3/8      | 7/8           | 12      | .19 |
| UR2-128  | A 04734  | 3/4     | 1/2     | 2-3/16  | 7/16     | 11/16         | 10      | .31 |
| UR2-1210 | A 04784  | 3/4     | 5/8     | 2-5/16  | 7/16     | 11/16         | 10      | .33 |

## EXTERNAL FLARE CONNECTORS, HALF UNION – EXTERNAL FLARE TO SOLDER

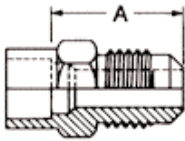

| Cat. No. | Part No. | Size  |           |        | Size Hex | Pcs. Per Ctn. | Wt./Ea. |
|----------|----------|-------|-----------|--------|----------|---------------|---------|
|          |          | Flare | OD Solder | A      |          |               |         |
| US3-44   | A 03431  | 1/4   | 1/4       | 11/16  | 7/16     | 25            | .03     |
| US3-45   | A 03466  | 1/4   | 5/16      | 11/16  | 7/16     | 25            | .04     |
| US3-46   | A 03494  | 1/4   | 3/8       | 11/16  | 1/2      | 25            | .03     |
| US3-64   | A 03443  | 3/8   | 1/4       | 7/8    | 5/8      | 25            | .08     |
| US3-65   | A 03464  | 3/8   | 5/16      | 7/8    | 5/8      | 25            | .07     |
| US3-66   | A 03492  | 3/8   | 3/8       | 7/8    | 5/8      | 25            | .06     |
| US3-68   | A 03547  | 3/8   | 1/2       | 7/8    | 5/8      | 10            | .08     |
| US3-610  | A 06601  | 3/8   | 5/8       | 7/8    | 3/4      | 10            | .08     |
| US3-86   | A 03504  | 1/2   | 3/8       | 1-1/16 | 3/4      | 25            | .11     |
| US3-88   | A 03546  | 1/2   | 1/2       | 1-1/16 | 3/4      | 15            | .11     |
| US3-810  | A 02259  | 1/2   | 5/8       | 1-1/16 | 3/4      | 10            | .10     |
| US3-108  | A 03519  | 5/8   | 1/2       | 1-1/4  | 7/8      | 10            | .16     |
| US3-1010 | A 02258  | 5/8   | 5/8       | 1-1/4  | 7/8      | 10            | .15     |
| US3-1012 | A 02272  | 5/8   | 3/4       | 1-1/4  | 7/8      | 10            | .15     |
| US3-1014 | A 02378  | 5/8   | 7/8       | 1-1/4  | 1        | 10            | .17     |
| US3-1212 | A 05307  | 3/4   | 3/4       | 1-7/16 | 1 1/16   | 5             | .25     |
| US3-1214 | A 05425  | 3/4   | 7/8       | 1-5/16 | 1 1/16   | 5             | .28     |

## CONNECTORS, HALF UNION – FLARE TO NPTFI

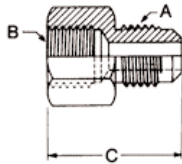

| Cat. No. | Part No. | Size    |         |         | Size Hex | Pcs. Per Ctn. | Wt./Ea. |
|----------|----------|---------|---------|---------|----------|---------------|---------|
|          |          | Flare A | NPTFI B | C       |          |               |         |
| U3-4A    | A 04622  | 1/4     | 1/8     | 1-1/32  | 9/16     | 25            | .04     |
| U3-4B    | A 04625  | 1/4     | 1/4     | 1-1/4   | 11/16    | 25            | .07     |
| U3-4C    | A 04961  | 1/4     | 3/8     | 1-9/32  | 13/16    | 15            | .08     |
| U3-6A    | A 04927  | 3/8     | 1/8     | 1-1/8   | 5/8      | 10            | .06     |
| U3-6B    | A 04624  | 3/8     | 1/4     | 1-5/16  | 11/16    | 25            | .09     |
| U3-6C    | A 04627  | 3/8     | 3/8     | 1-3/8   | 13/16    | 15            | .10     |
| U3-6D    | A 08104  | 3/8     | 1/2     | 1-5/8   | 1        | 15            | .16     |
| U3-8B    | A 04928  | 1/2     | 1/4     | 1-13/32 | 3/4      | 15            | .11     |
| U3-8C    | A 04727  | 1/2     | 3/8     | 1-1/2   | 13/16    | 15            | .12     |
| U3-8D    | A 04728  | 1/2     | 1/2     | 1-3/4   | 1        | 15            | .18     |
| U3-10C   | A 04929  | 5/8     | 3/8     | 1-19/32 | 7/8      | 10            | .15     |
| U3-10D   | A 04819  | 5/8     | 1/2     | 1-13/16 | 1        | 10            | .20     |
| U3-10E   | A 04977  | 5/8     | 3/4     | 1-29/32 | 1 1/4    | 10            | .36     |

# 45° FLARE FITTINGS

**BRASS**

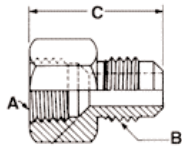
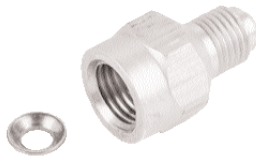

## INTERNAL FLARE TO EXTERNAL FLARE UNION

| Cat. No. | Part No. | Size    |         |         | Size Hex | Pcs. Per Ctn. | Wt./Ea. |
|----------|----------|---------|---------|---------|----------|---------------|---------|
|          |          | Flare A | Flare B | C       |          |               |         |
| UR3-43   | A 05147  | 1/4     | 3/16    | 1-1/32  | 5/8      | 10            | .05     |
| UR3-46   | A 05041  | 1/4     | 3/8     | 1-1/8   | 5/8      | 15            | .04     |
| UR3-48   | A 08127  | 1/4     | 1/2     | 1-1/4   | 3/4      | 10            | .11     |
| UR3-64   | A 00479  | 3/8     | 1/4     | 1-7/32  | 13/16    | 15            | .09     |
| UR3-68   | A 04888  | 3/8     | 1/2     | 1-13/32 | 13/16    | 15            | .12     |
| UR3-84   | A 00480  | 1/2     | 1/4     | 1-3/8   | 15/16    | 15            | .11     |
| UR3-86   | A 00481  | 1/2     | 3/8     | 1-7/16  | 15/16    | 15            | .13     |
| UR3-810  | A 04879  | 1/2     | 5/8     | 1-5/8   | 15/16    | 10            | .19     |
| UR3-108  | A 04770  | 5/8     | 1/2     | 1-11/16 | 1 1/16   | 10            | .18     |
| UR3-1012 | A 04878  | 5/8     | 3/4     | 1-29/32 | 1 1/16   | 10            | .29     |
| UR3-1210 | A 04826  | 3/4     | 5/8     | 1-31/32 | 1 5/16   | 10            | .30     |

1 Soft Copper Gasket Furnished With Each Part

## INTERNAL FLARE UNION

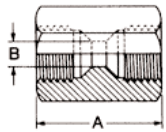

| Cat. No. | Part No. | Size  |       |        | A   | B  | Pcs. Per Ctn. | Wt./Ea. |
|----------|----------|-------|-------|--------|-----|----|---------------|---------|
|          |          | Flare | Hex   |        |     |    |               |         |
| U4-4     | A 00385  | 1/4   | 5/8   | 1      | 1/4 | 10 | .08           |         |
| U4-6     | A 00386  | 3/8   | 13/16 | 1-1/4  | 3/8 | 10 | .12           |         |
| U4-8     | A 00387  | 1/2   | 15/16 | 1-7/16 | 1/2 | 10 | .19           |         |

2 Soft Copper Gasket Furnished With Each Part

## INTERNAL FLARE SWIVEL UNION

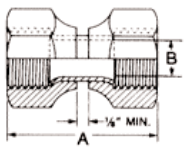

| Cat. No. | Part No. | Size  |        |         | A    | B  | Pcs. Per Ctn. | Wt./Ea. |
|----------|----------|-------|--------|---------|------|----|---------------|---------|
|          |          | Flare | Hex    |         |      |    |               |         |
| US4-4    | A 13563  | 1/4   | 5/8    | 1-3/8   | 3/16 | 15 | .12           |         |
| US4-5    | A 13564  | 5/16  | 11/16  | 1-7/16  | 1/4  | 15 | .10           |         |
| US4-6    | A 13565  | 3/8   | 13/16  | 1-9/16  | 5/16 | 15 | .16           |         |
| US4-8    | A 13567  | 1/2   | 15/16  | 1-13/16 | 7/16 | 15 | .24           |         |
| US4-10   | A 13568  | 5/8   | 1-1/16 | 2-1/16  | 9/16 | 15 | .35           |         |

## FUSIBLE CONNECTORS, HALF UNION – FLARE TO FPTFE

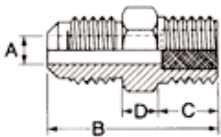

| Cat. No. | UL Part No. | CE Part No. | Flare | Size NPTFE | Hex   |      | A in | B cm   | C in | D cm | Melting Temp.* | Per Ctn. | Wt./Ea. |       |    |     |
|----------|-------------|-------------|-------|------------|-------|------|------|--------|------|------|----------------|----------|---------|-------|----|-----|
|          |             |             |       |            | in    | cm   |      |        |      |      |                |          |         |       |    |     |
| FU-4B    | A 14062     | B 35136     | 1/4   | 1/4        | 9/16  | 3/16 | .48  | 1-1/4  | 3.18 | 9/16 | 1.43           | 3/16     | .48     | 283°F | 10 | .07 |
| FU-4C    | A 14063     | B 35137     | 1/4   | 3/8        | 11/16 | 3/16 | .48  | 1-5/16 | 3.33 | 9/16 | 1.43           | 1/4      | .64     | 283°F | 10 | .09 |
| FU-6C    | A 14064     | B 35138     | 3/8   | 3/8        | 11/16 | 9/32 | .71  | 1-7/16 | 3.65 | 9/16 | 1.43           | 1/4      | .64     | 283°F | 10 | .12 |
| FU-4B    | A 14023     | B 35127     | 1/4   | 1/4        | 9/16  | 3/16 | .48  | 1-1/4  | 3.18 | 9/16 | 1.43           | 3/16     | .48     | 210°F | 10 | .06 |
| FU-4C    | A 14025     | B 35129     | 1/4   | 3/8        | 11/16 | 3/16 | .48  | 1-5/16 | 3.33 | 9/16 | 1.43           | 1/4      | .64     | 210°F | 10 | .09 |
| FU-6C    | A 14026     | B 35130     | 3/8   | 3/8        | 11/16 | 9/32 | .71  | 1-7/16 | 3.65 | 9/16 | 1.43           | 1/4      | .64     | 210°F | 10 | .12 |
| FU-4B    | A 14024     | B 35128     | 1/4   | 1/4        | 9/16  | 3/16 | .48  | 1-1/4  | 3.18 | 9/16 | 1.43           | 3/16     | .48     | 168°F | 10 | .06 |
| FU-4C    | A 14050     | B 35132     | 1/4   | 3/8        | 11/16 | 3/16 | .48  | 1-5/16 | 3.33 | 9/16 | 1.43           | 1/4      | .64     | 168°F | 10 | .09 |
| FU-6C    | A 14027     | B 35131     | 3/8   | 3/8        | 11/16 | 9/32 | .71  | 1-7/16 | 3.65 | 9/16 | 1.43           | 1/4      | .64     | 168°F | 10 | .13 |

Listed by Underwriters Laboratories, Inc., for use in the USA and Canada.  
CE Compliant for European market.



## 45° FLARE FITTINGS

## BRASS

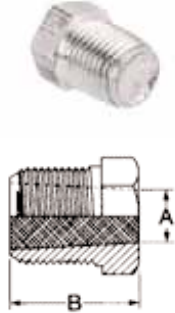

## FUSIBLE PIPE PLUGS

| Cat. No. | UL Part No. | CE Part No. | Size  |        |      | A   |       | B    |       | Melting Temp.* | Per Ctn. | Wt./Ea. |
|----------|-------------|-------------|-------|--------|------|-----|-------|------|-------|----------------|----------|---------|
|          |             |             | NPTFE | Hex    | in   | cm  | in    | cm   |       |                |          |         |
| FP-A     | A 14058     | B 35133     | 1/8   | 7/16   | 7/32 | .56 | 19/32 | 1.51 | 283°F | 10             | .02      |         |
| FP-B     | A 14059     | B 35134     | 1/4   | 9/16   | 1/4  | .64 | 25/32 | 1.98 | 283°F | 15             | .05      |         |
| FP-C     | A 14060     | B 35135     | 3/8   | 1 1/16 | 3/8  | .95 | 27/32 | 2.14 | 283°F | 15             | .08      |         |
| FP-A     | A 14017     | B 35122     | 1/8   | 7/16   | 7/32 | .56 | 19/32 | 1.51 | 210°F | 10             | .03      |         |
| FP-B     | A 14018     | B 35123     | 1/4   | 9/16   | 1/4  | .64 | 25/32 | 1.98 | 210°F | 15             | .05      |         |
| FP-C     | A 14021     | B 35125     | 3/8   | 1 1/16 | 3/8  | .95 | 27/32 | 2.14 | 210°F | 15             | .06      |         |
| FP-A     | A 15214     | B 35139     | 1/8   | 7/16   | 7/32 | .56 | 19/32 | 1.51 | 168°F | 10             | .02      |         |
| FP-B     | A 14019     | B 35124     | 1/4   | 9/16   | 1/4  | .64 | 25/32 | 1.98 | 168°F | 15             | .04      |         |
| FP-C     | A 14022     | B 35126     | 3/8   | 1 1/16 | 3/8  | .95 | 27/32 | 2.14 | 168°F | 15             | .06      |         |

Listed by Underwriters Laboratories, Inc., for use in the USA and Canada.  
CE Compliant for European market.

## REFRIGERANT DRUM ADAPTERS

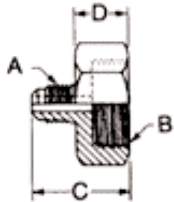
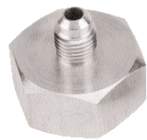

| Cat. No. | Part No. | Size  |      |       | C    | D     | Hex | Pcs. Per Ctn. | Wt./Ea. | Replacement Gasket |
|----------|----------|-------|------|-------|------|-------|-----|---------------|---------|--------------------|
|          |          | Flare | NPSM | B     |      |       |     |               |         |                    |
| KI-1     | A 08073  | 1/4   | 3/4  | 1-1/8 | 7/16 | 1-1/4 | 10  | .16           |         |                    |
| KI-3     | A 08274  | 3/8   | 3/4  | 1-1/4 | 7/16 | 1-1/4 | 10  | .19           | A 08074 |                    |
| KI-5     | A 08276  | 1/2   | 3/4  | 1-3/8 | 7/16 | 1-1/4 | 10  | .19           |         |                    |
| KI-8     | A 08166  | 1/4   | 1/2  | 1-1/8 | 7/16 | 1-1/8 | 10  | .15           | A 08167 |                    |

Furnished with Gasket  
Flare to Internal Straight Pipe (NPSM)

## 90° ELBOWS, HALF UNION – FLARE TO NPTFE

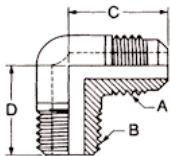

| Cat. No. | Part No. | Size  |       |         | C       | D  | Pcs. Per Ctn. | Wt./Ea. |
|----------|----------|-------|-------|---------|---------|----|---------------|---------|
|          |          | Flare | NPTFE | B       |         |    |               |         |
| EI-4A    | A 00335  | 1/4   | 1/8   | 15/16   | 25/32   | 25 | .04           |         |
| EI-4B    | A 04890  | 1/4   | 1/4   | 29/32   | 15/16   | 25 | .08           |         |
| EI-4C    | A 04812  | 1/4   | 3/8   | 15/16   | 1-1/32  | 25 | .09           |         |
| EI-6A    | A 04937  | 3/8   | 1/8   | 1-1/32  | 29/32   | 25 | .08           |         |
| EI-6B    | A 00337  | 3/8   | 1/4   | 1-1/16  | 1-1/16  | 25 | .09           |         |
| EI-6C    | A 04889  | 3/8   | 3/8   | 1-1/16  | 1-3/32  | 25 | .11           |         |
| EI-6D    | A 04886  | 3/8   | 1/2   | 1-1/8   | 1-11/32 | 25 | .16           |         |
| EI-8B    | A 05044  | 1/2   | 1/4   | 1-7/32  | 1-3/16  | 10 | .13           |         |
| EI-8C    | A 00339  | 1/2   | 3/8   | 1-7/32  | 1-1/8   | 15 | .17           |         |
| EI-8D    | A 04887  | 1/2   | 1/2   | 1-9/32  | 1-3/8   | 15 | .17           |         |
| EI-8E    | A 05072  | 1/2   | 3/4   | 1-11/32 | 1-3/8   | 10 | .24           |         |
| EI-10C   | A 04856  | 5/8   | 3/8   | 1-15/32 | 1-1/4   | 10 | .17           |         |
| EI-10D   | A 04538  | 5/8   | 1/2   | 1-15/32 | 1-7/16  | 10 | .20           |         |
| EI-10E   | A 05054  | 5/8   | 3/4   | 1-15/32 | 1-1/2   | 10 | .26           |         |
| EI-12D   | A 04776  | 3/4   | 1/2   | 1-21/32 | 1-1/2   | 10 | .32           |         |
| EI-12E   | A 04746  | 3/4   | 3/4   | 1-21/32 | 1-5/8   | 10 | .35           |         |

# 45° FLARE FITTINGS

**BRASS**

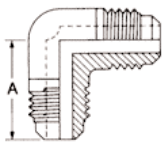

## 90° ELBOW, UNION – FLARE TO FLARE

| Cat. No. | Part No. | Size  |         | Pcs. Per Ctn. | Wt./Ea. |
|----------|----------|-------|---------|---------------|---------|
|          |          | Flare | A       |               |         |
| E2-4     | A 00147  | 1/4   | 29/32   | 25            | .07     |
| E2-6     | A 00146  | 3/8   | 1-1/16  | 25            | .10     |
| E2-8     | A 00145  | 1/2   | 1-7/32  | 15            | .14     |
| E2-10    | A 04539  | 5/8   | 1-15/32 | 10            | .21     |
| E2-12    | A 04745  | 3/4   | 1-21/32 | 5             | .39     |

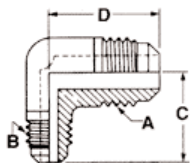

## 90° ELBOW, REDUCING UNION – FLARE TO FLARE

| Cat. No. | Part No. | Size |     | Pcs. Per Ctn. | Wt./Ea. |
|----------|----------|------|-----|---------------|---------|
|          |          | A    | B   |               |         |
| ER2-84   | A 04885  | 1/2  | 1/4 | 25            | .13     |
| ER2-86   | A 05042  | 1/2  | 3/8 | 25            | .17     |

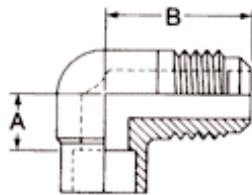

## 90° SOLDER ELBOW, HALF UNION – FLARE TO SOLDER

| Cat. No. | Part No. | Size  |           |       |         | Pcs. Per Ctn. | Wt./Ea. |
|----------|----------|-------|-----------|-------|---------|---------------|---------|
|          |          | Flare | OD Solder | A     | B       |               |         |
| ES2-44   | A 03449  | 1/4   | 1/4       | 23/64 | 29/32   | 25            | .04     |
| ES2-66   | A 03511  | 3/8   | 3/8       | 15/32 | 1-5/64  | 20            | .08     |
| ES2-68   | A 07852  | 3/8   | 1/2       | 13/32 | 1-3/64  | 10            | .11     |
| ES2-88   | A 07851  | 1/2   | 1/2       | 15/32 | 1-7/32  | —             | .12     |
| ES2-1010 | A 06611  | 5/8   | 5/8       | 35/64 | 1-13/32 | —             | .19     |

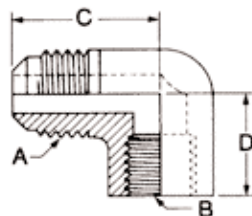

## 90° ELBOW – EXTERNAL FLARE TO NPTFI

| Cat. No. | Part No. | Size    |         |        |       | Pcs. Per Ctn. | Wt./Ea. |
|----------|----------|---------|---------|--------|-------|---------------|---------|
|          |          | Flare A | NPTFI B | C      | D     |               |         |
| E3-4A    | A 04630  | 1/4     | 1/8     | 29/32  | 29/32 | 25            | .06     |
| E3-4B    | A 05007  | 1/4     | 1/4     | 1-1/16 | 21/32 | 25            | .13     |
| E3-6B    | A 04632  | 3/8     | 1/4     | 1-1/8  | 1-1/8 | 25            | .15     |
| E3-6C    | A 04914  | 3/8     | 3/8     | 1-9/64 | 3/4   | 25            | .19     |
| E3-8D    | A 05056  | 1/2     | 1/2     | 1-3/8  | 15/16 | 15            | .33     |



## 45° FLARE FITTINGS

BRASS

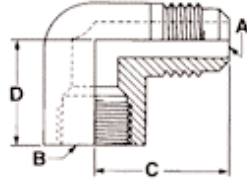

## 90° ELBOW – EXTERNAL FLARE TO INTERNAL FLARE

| Cat. No. | Part No. | Size       |            |         |        | Pcs.<br>Per Ctn. | Wt.<br>/Ea. |
|----------|----------|------------|------------|---------|--------|------------------|-------------|
|          |          | Flare<br>A | Flare<br>B | C       | D      |                  |             |
| E4-44    | A 04898  | 1/4        | 1/4        | 15/16   | 7/8    | 25               | .13         |
| E4-66    | A 08082  | 3/8        | 3/8        | 1-7/32  | 1-1/16 | 25               | .24         |
| E4-88    | A 04897  | 1/2        | 1/2        | 1-11/32 | 1-1/8  | 15               | .22         |

I Soft Copper Gasket Furnished With Each Part

## 90° SWIVEL ELBOW – EXTERNAL FLARE TO INTERNAL FLARE

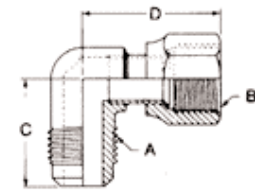

| Cat. No. | Part No. | Size       |            |         |         | Pcs.<br>Per Ctn. | Wt.<br>/Ea. |
|----------|----------|------------|------------|---------|---------|------------------|-------------|
|          |          | Flare<br>A | Flare<br>B | C       | D       |                  |             |
| ES4-44   | A 15940  | 1/4        | 1/4        | 29/32   | 1-1/4   | 4                | .13         |
| ES4-66   | A 15941  | 3/8        | 3/8        | 1-5/64  | 1-27/64 | 4                | .19         |
| ES4-88   | A 15943  | 1/2        | 1/2        | 1-7/32  | 1-17/32 | 4                | .22         |
| ES4-1010 | A 15944  | 5/8        | 5/8        | 1-13/32 | 1-3/4   | 4                | .31         |
| ES4-1212 | A 15945  | 3/4        | 3/4        | 1-21/32 | 2-1/32  | 4                | .58         |

## RIGHT ANGLE TWO-WAY TEES

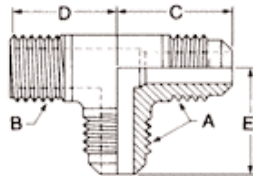

| Cat. No. | Part No. | Size       |            |         |        |         | Pcs.<br>Per Ctn. | Wt./Ea. |
|----------|----------|------------|------------|---------|--------|---------|------------------|---------|
|          |          | Flare<br>A | NPTFE<br>B | C       | D      | E       |                  |         |
| T3-4A    | A 00127  | 1/4        | 1/8        | 15/16   | 51/64  | 15/16   | 25               | .08     |
| T3-4B    | A 04998  | 1/4        | 1/4        | 15/16   | 1-1/16 | 15/16   | 25               | .11     |
| T3-6B    | A 00133  | 3/8        | 1/4        | 1-1/16  | 1-1/16 | 1-1/16  | 25               | .14     |
| T3-6C    | A 04941  | 3/8        | 3/8        | 1-1/16  | 1-3/32 | 1-1/16  | 25               | .15     |
| T3-8C    | A 04778  | 1/2        | 3/8        | 1-7/32  | 1-1/8  | 1-7/32  | 15               | .18     |
| T3-8D    | A 04944  | 1/2        | 1/2        | 1-11/32 | 1-3/8  | 1-11/32 | 10               | .26     |
| T3-10D   | A 04779  | 5/8        | 1/2        | 1-13/32 | 1-3/8  | 1-13/32 | 10               | .28     |

## TWO-WAY TEES

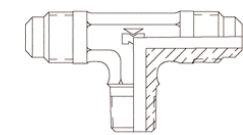

| Cat. No. | Part No. | Size       |            |         |        | Pcs.<br>Per Ctn. | Wt.<br>/Ea. |
|----------|----------|------------|------------|---------|--------|------------------|-------------|
|          |          | Flare<br>A | NPTFE<br>B | C       | D      |                  |             |
| T1-4A    | A 00345  | 1/4        | 1/8        | 15/16   | 13/16  | 25               | .07         |
| T1-4B    | A 04859  | 1/4        | 1/4        | 29/32   | 1-1/32 | 25               | .09         |
| T1-4C    | A 04771  | 1/4        | 3/8        | 15/16   | 1-1/32 | 15               | .12         |
| T1-6B    | A 00347  | 3/8        | 1/4        | 1-1/16  | 1-1/16 | 25               | .11         |
| T1-6C    | A 04922  | 3/8        | 3/8        | 1-1/16  | 1-1/16 | 15               | .14         |
| T1-8B    | A 05246  | 1/2        | 1/4        | 1-7/32  | 1-3/16 | 12               | .18         |
| T1-8C    | A 00349  | 1/2        | 3/8        | 1-7/32  | 1-1/8  | 15               | .19         |
| T1-8D    | A 04924  | 1/2        | 1/2        | 1-11/32 | 1-3/8  | 10               | .26         |
| T1-10D   | A 04754  | 5/8        | 1/2        | 1-13/32 | 1-3/8  | 10               | .28         |

## THREE-WAY TEES

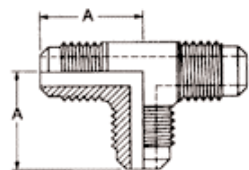

| Cat. No. | Part No. | Size  |         | Pcs.<br>Per Ctn. | Wt./Ea. |
|----------|----------|-------|---------|------------------|---------|
|          |          | Flare | A       |                  |         |
| T2-4     | A 00340  | 1/4   | 15/16   | 25               | .07     |
| T2-6     | A 00342  | 3/8   | 1-1/16  | 15               | .17     |
| T2-8     | A 00344  | 1/2   | 1-7/32  | 15               | .20     |
| T2-10    | A 04541  | 5/8   | 1-13/32 | 10               | .30     |
| T2-12    | A 04749  | 3/4   | 1-21/32 | 5                | .68     |

# 45° FLARE FITTINGS

**BRASS**

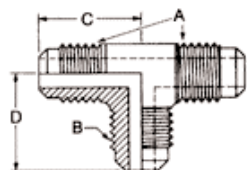
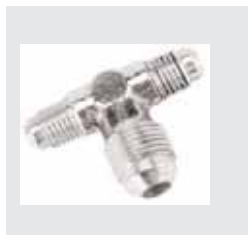

## THREE-WAY REDUCING TEES

| Cat. No. | Part No. | Size    |         | C       | D       | Pcs. Per Ctn. | Wt. /Ea. |
|----------|----------|---------|---------|---------|---------|---------------|----------|
|          |          | Flare A | Flare B |         |         |               |          |
| TR2-46   | A 04994  | 1/4     | 3/8     | 29/32   | 1-1/16  | 25            | .11      |
| TR2-64   | A 04574  | 3/8     | 1/4     | 1-1/16  | 29/32   | 25            | .12      |
| TR2-68   | A 04547  | 3/8     | 1/2     | 1-1/8   | 1-7/32  | 15            | .19      |
| TR2-84   | A 04558  | 1/2     | 1/4     | 1-7/32  | 31/32   | 10            | .21      |
| TR2-86   | A 04559  | 1/2     | 3/8     | 1-7/32  | 1-1/8   | 15            | .22      |
| TR2-810  | A 04991  | 1/2     | 5/8     | 1-11/32 | 1-13/32 | 10            | .28      |

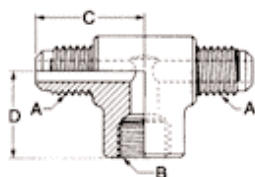

## THREE-WAY TEES – INTERNAL BRANCH

| Cat. No. | Part No. | Size    |         | C     | D     | Pcs. Per Ctn. | Wt. /Ea. |
|----------|----------|---------|---------|-------|-------|---------------|----------|
|          |          | Flare A | Flare B |       |       |               |          |
| T6-4     | A 06330  | 1/4     | 1/4     | 15/16 | 29/32 | 25            | .14      |

1 Soft Copper Gasket Furnished With Each Part

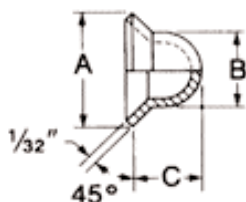

## COPPER FLARE SEAL BONNETS

| Cat. No. | Part No. | Size Flare | A     |          |       | C   | Pcs. Per Ctn. | Wt./Ea. |
|----------|----------|------------|-------|----------|-------|-----|---------------|---------|
|          |          |            | Max.  | +/- 1/64 | Min.  |     |               |         |
| B1-3     | A 04737  | 3/16       | 5/16  | 5/32     | 5/32  | 25  | .001          |         |
| B1-4     | A 00414  | 1/4        | 23/64 | 7/32     | 7/32  | 100 | .001          |         |
| B1-5     | A 04935  | 5/16       | 27/64 | 9/32     | 9/32  | 50  | .004          |         |
| B1-6     | A 00415  | 3/8        | 35/64 | 23/64    | 11/32 | 25  | .004          |         |
| B1-8     | A 00416  | 1/2        | 21/32 | 15/32    | 13/32 | 100 | .008          |         |
| B1-10    | A 00485  | 5/8        | 49/64 | 39/64    | 7/16  | 20  | .009          |         |
| B1-12    | A 04738  | 3/4        | 61/64 | 23/32    | 9/16  | 25  | .015          |         |

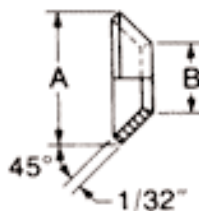

## COPPER FLARE GASKETS

| Cat. No. | Part No. | Size Flare | A     |          | B   | Pcs. Per Ctn. | Wt./Ea. |
|----------|----------|------------|-------|----------|-----|---------------|---------|
|          |          |            | Max.  | +/- 1/32 |     |               |         |
| B2-3     | A 05156  | 3/16       | 5/16  | 1/8      | 50  | .001          |         |
| B2-4     | A 00401  | 1/4        | 23/64 | 3/16     | 100 | .001          |         |
| B2-5     | A 04811  | 5/16       | 27/64 | 7/32     | 50  | .001          |         |
| B2-6     | A 00402  | 3/8        | 35/64 | 9/32     | 100 | .002          |         |
| B2-8     | A 00403  | 1/2        | 21/32 | 13/32    | 100 | .002          |         |
| B2-10    | A 05186  | 5/8        | 49/64 | 1/2      | 50  | .003          |         |
| B2-12    | A 04822  | 3/4        | 61/64 | 5/8      | 25  | .004          |         |

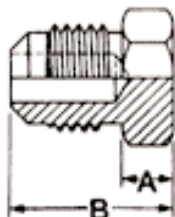

## FLARE PLUGS

| Cat. No. | Part No. | Size Flare | A    |          | Size Hex | Pcs. Per Ctn. | Wt./Ea. |
|----------|----------|------------|------|----------|----------|---------------|---------|
|          |          |            | Max. | +/- 1/32 |          |               |         |
| P2-3     | A 05045  | 3/16       | 5/32 | 19/32    | 3/8      | 15            | .01     |
| P2-4     | A 00121  | 1/4        | 3/16 | 11/16    | 7/16     | 25            | .02     |
| P2-5     | A 00124  | 5/16       | 7/32 | 25/32    | 1/2      | 15            | .03     |
| P2-6     | A 00122  | 3/8        | 1/4  | 7/8      | 5/8      | 25            | .06     |
| P2-8     | A 00123  | 1/2        | 5/16 | 1-1/16   | 3/4      | 25            | .09     |
| P2-10    | A 04536  | 5/8        | 5/16 | 1-3/16   | 7/8      | 15            | .14     |
| P2-12    | A 04757  | 3/4        | 5/16 | 1-5/16   | 1-1/16   | 10            | .23     |



## 45° FLARE FITTINGS

BRASS

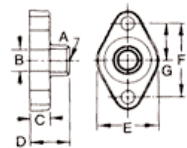
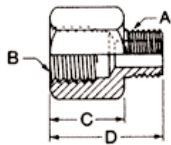
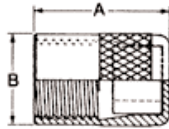
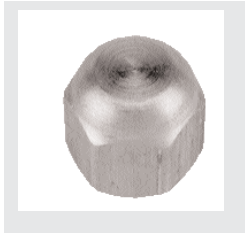

## FLARE SEAL CAP

| Cat. No. | Part No. | Size  |       |        | Size Hex | Pcs. Per Ctn. | Wt./Ea. |
|----------|----------|-------|-------|--------|----------|---------------|---------|
|          |          | Flare | A     | B      |          |               |         |
| N5-4     | A 04544  | 1/4   | 11/32 | 9/16   | 9/16     | 50            | .03     |
| N5-5     | A 04758  | 5/16  | 3/8   | 9/16   | 5/8      | 25            | .03     |
| N5-6     | A 04545  | 3/8   | 7/16  | 11/16  | 3/4      | 25            | .05     |
| N5-8     | A 04546  | 1/2   | 35/64 | 13/16  | 7/8      | 25            | .08     |
| N5-10    | A 04560  | 5/8   | 5/8   | 15/16  | 1-1/16   | 10            | .14     |
| N5-12    | A 04951  | 3/4   | 3/4   | 1-3/32 | 1-5/16   | 10            | .21     |

## FLARE SEAL CAPS W/NEOPRENE SEAL GASKET\*

| Cat. No. | Part No. | Size  |       |       | Pcs. Per Ctn. | Wt./Ea. |
|----------|----------|-------|-------|-------|---------------|---------|
|          |          | Flare | A     | B     |               |         |
| NFT5-4   | A 16447  | 1/4   | 9/16  | 31/64 | 3500          | .02     |
| NFT5-6   | A 16448  | 3/8   | 47/64 | 43/64 | 1400          | .04     |

Finger Tightening\*

## PIPE PLUGS

| Cat. No. | Part No. | Size  |      |        | Size Hex | Pcs. Per Ctn. | Wt./Ea. |
|----------|----------|-------|------|--------|----------|---------------|---------|
|          |          | NPTFE | A    | B      |          |               |         |
| P3-A     | A 00250  | 1/8   | 3/16 | 5/8    | 1/2      | 50            | .03     |
| P3-B     | A 00249  | 1/4   | 1/4  | 13/16  | 11/16    | 50            | .06     |
| P3-C     | A 00425  | 3/8   | 1/4  | 3/4    | 11/16    | 25            | .07     |
| P3-D     | A 04759  | 1/2   | 5/16 | 7/8    | 7/8      | 25            | .13     |
| P3-E     | A 05004  | 3/4   | 5/16 | 1-1/32 | 1 1/8    | 10            | .21     |

## BUSHINGS – EXTERNAL PIPE THREAD TO INTERNAL PIPE THREAD

| Cat. No. | Part No. | Size |         |         |       |        | Size Per Ctn. | Pcs. Wt./Ea. |
|----------|----------|------|---------|---------|-------|--------|---------------|--------------|
|          |          | A    | NPTFE B | NPTFI C | D     | Hex    |               |              |
| RI-AB    | A 08756  | 1/8  | 1/4     | 39/64   | 59/64 | 11/16  | 25            | .05          |
| RI-BA    | A 00630  | 1/4  | 1/8     | 3/32    | 19/32 | 9/16   | 25            | .02          |
| RI-CB    | A 00631  | 3/8  | 1/4     | 3/16    | 11/16 | 11/16  | 25            | .04          |
| RI-DB    | A 00492  | 1/2  | 1/4     | 3/16    | 3/4   | 7/8    | 25            | .08          |
| RI-DC    | A 00632  | 1/2  | 3/8     | 3/16    | 3/4   | 7/8    | 25            | .05          |
| RI-EC    | A 00493  | 3/4  | 3/8     | 3/16    | 13/16 | 1-1/16 | 10            | .11          |
| RI-ED    | A 00633  | 3/4  | 1/2     | 3/16    | 13/16 | 1-1/16 | 10            | .09          |

## FLANGE – FORGED BRASS – 2 BOLT HOLE W/SERRATED GASKET SURFACE

| Part No. | Size OD Solder |         |     | Bolt Hole Centers |       |       |       | Dia Of Bolt Holes | Wt./Ea. |
|----------|----------------|---------|-----|-------------------|-------|-------|-------|-------------------|---------|
|          | A              | B       | C   | D                 | E     | F     | G     |                   |         |
| A 08314  | 5/8            | 9/16    | 3/4 | 1 3/16            | 1-1/2 | 1-5/8 | 13/16 | 11/32             | .45     |
| A 05299  | 3/4            | 11/16   | 3/4 | 1-5/16            | 1-1/2 | 1-5/8 | 13/16 | 3/8               | .42     |
| A 09215  | 7/8            | 13/16   | 3/4 | 1-7/16            | 1-1/2 | 1-5/8 | 13/16 | 11/32             | .42     |
| A 08315  | 7/8            | 13/16   | 3/4 | 1-7/16            | 2-1/4 | 2-3/4 | 1-3/8 | 17/32             | 1.08    |
| A 05151  | 1-1/8          | 1-1/16  | 3/4 | 1-9/16            | 2-1/4 | 2-3/4 | 1-3/8 | 17/32             | 1.11    |
| A 05074  | 1-3/8          | 1-19/64 | 3/4 | 1-17/32           | 2-1/4 | 2-3/4 | 1-3/8 | 17/32             | 1.00    |

# 45° FLARE FITTINGS

**BRASS**

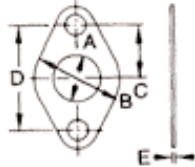

## GASKETS – 2 BOLT HOLE – ASBESTOS-FREE MATERIAL

| Part No. | A      | B     | C     | Bolt Hole Centers |      | Dia Of Bolt Holes | Wt./Ea. |
|----------|--------|-------|-------|-------------------|------|-------------------|---------|
|          |        |       |       | D                 | E    |                   |         |
| A 04582  | 9/16   | 1 1/8 | 13/16 | 1-5/8             | 1/32 | 11/32             | .003    |
| N 02308  | 13/16  | 1 1/2 | 13/16 | 1-5/8             | 1/32 | 11/32             | .004    |
| N 02307  | 13/16  | 1 1/2 | 7/8   | 1-3/4             | 1/32 | 11/32             | .004    |
| A 05152  | 1 3/16 | 2 1/4 | 1-3/8 | 2-3/4             | 1/16 | 17/32             | .002    |
| P 36396  | 1 5/16 | 2 1/4 | 3-1/8 | 2-3/4             | 1/16 | 17/32             | .002    |

## FLANGE BOLTS AND NUTS

| Part No. | Asbestos-Free Material                         |  | Wt./Ea. |
|----------|--|--|---------|
|          | Description                                    |  |         |
| A 06567  | 1/2-13 Bolt - 2-1/4 long (For 17/32 Dia. Hole) |  | .15     |
| A 06569  | Nut For Above                                  |  | .04     |

## FLANGES – FORGED BRASS – 4 BOLT HOLE WITH GROOVE

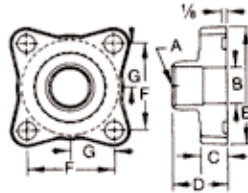
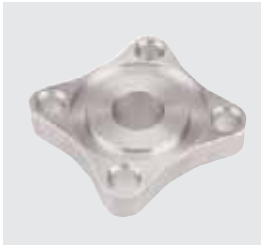

| Part No. | Size Solder |         | Bolt Hole Centers |         |         |       | Dia Of Bolt Holes | Wt./Ea. |      |
|----------|-------------|---------|-------------------|---------|---------|-------|-------------------|---------|------|
|          | A           | B       | C                 | D       | E       | F     |                   |         | G    |
| A 08630  | 1-1/8       | 1-11/16 | 3/4               | 1-9/16  | 3-13/32 | 2-1/2 | 1-1/4             | 17/32   | 1.88 |
| A 08631  | 1-3/8       | 1-19/64 | 3/4               | 1-5/8   | 3-13/32 | 2-1/2 | 1-1/4             | 17/32   | 1.75 |
| A 08261  | 1-5/8       | 1-17/32 | 3/4               | 1-3/4   | 3-13/32 | 2-1/2 | 1-1/4             | 17/32   | 1.69 |
| A 08633  | 2-1/8       | 1-15/16 | 3/4               | 1-23/32 | 3-13/32 | 2-1/2 | 1-1/4             | 17/32   | 1.38 |

Gasket - Asbestos-free material

Part No. A 8634 used for 4 bolt-hole tongue and groove flanges.

Groove diameters 2-25/32" x 2-1/16"

## FLANGES – FORGED BRASS – 4 BOLT HOLE WITH TONGUE

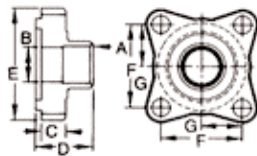
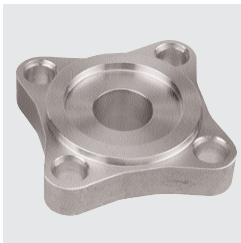

| Part No. | Size Solder |         | Bolt Hole Centers |         |         |       | Dia Of Bolt Holes | Wt./Ea. |      |
|----------|-------------|---------|-------------------|---------|---------|-------|-------------------|---------|------|
|          | A           | B       | C                 | D       | E       | F     |                   |         | G    |
| A 08629  | 1-1/8       | 1-11/16 | 3/4               | 1-23/32 | 3-13/32 | 2 1/2 | 1-1/4             | 17/32   | 2.06 |
| A 05150  | 1-3/8       | 1-19/64 | 3/4               | 1-25/32 | 3-13/32 | 2 1/2 | 1-1/4             | 17/32   | 2.00 |
| A 05148  | 1-5/8       | 1-17/32 | 3/4               | 1-29/32 | 3-13/32 | 2 1/2 | 1-1/4             | 17/32   | 1.94 |
| A 08632  | 2-1/8       | 1-15/16 | 3/4               | 1-7/8   | 3-13/32 | 2 1/2 | 1-1/4             | 17/32   | 1.63 |

Groove Diameters 2-3/4" x 2-3/16"

## FLANGES – FORGED BRASS – 4 BOLT HOLE WITH TONGUE

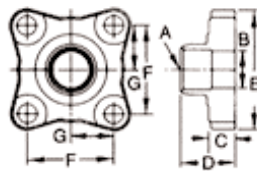
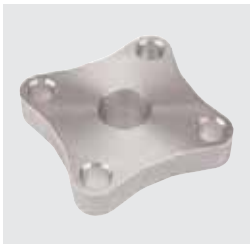

| Part No. | Size Solder |         | Bolt Hole Centers |         |         |       | Dia Of Bolt Holes | Wt./Ea. |      |
|----------|-------------|---------|-------------------|---------|---------|-------|-------------------|---------|------|
|          | A           | B       | C                 | D       | E       | F     |                   |         | G    |
| A 08624  | 1-1/8       | 1-11/16 | 3/4               | 1-9/16  | 3-13/32 | 2-1/2 | 1-1/4             | 17/32   | 1.94 |
| A 08625  | 1-3/8       | 1-19/64 | 3/4               | 1-5/8   | 3-13/32 | 2-1/2 | 1-1/4             | 17/32   | 1.88 |
| A 08626  | 1-5/8       | 1-17/32 | 3/4               | 1-13/16 | 3-13/32 | 2-1/2 | 1-1/4             | 17/32   | 1.88 |
| A 08627  | 2-1/8       | 1-1/64  | 3/4               | 1-23/32 | 3-13/32 | 2-1/2 | 1-1/4             | 17/32   | 1.50 |

## GASKET – 4 BOLT HOLE

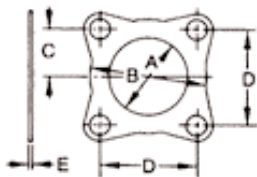

| Part No. | A | B | C | D | E | Dia Of Bolt Holes | Wt./Ea. |
|----------|---|---|---|---|---|-------------------|---------|
|          |   |   |   |   |   |                   |         |

Asbestos-Free Compound



TUBE & PIPE

METAL FITTINGS & NIPPLES

PLASTIC FITTINGS

VALVES

FILTER-DRYERS & STRAINERS

# PVC Sch. 40 Pressure Fittings



Superior strength and enhanced performance are the hallmarks of Mueller's PVC Schedule 40 pressure plastic fittings. With the heritage of being designed and tested under real world "cyclic" pressure conditions, Mueller's pressure plastic fittings have what it takes to stand up to what the "real world" dishes out. Along with superior strength comes superior performance; like excellent corrosion resistance, smoother inner walls for low pressure drops and excellent chemical resistance. Mueller offers a full line of quality PVC Schedule 40 pressure fittings to meet most residential, commercial, industrial and irrigation needs.



## TEE

## PVC SCHEDULE 40



### CONNECTION- SLIP x SLIP x SLIP

| Part Number | Size   | Inner/Master Carton Qty | Master Weight (lbs.) |
|-------------|--------|-------------------------|----------------------|
| 401-005     | 1/2"   | 50/400                  | 17.4                 |
| 401-007     | 3/4"   | 50/300                  | 4.5                  |
| 401-010     | 1"     | NA/50                   | 7.4                  |
| 401-012     | 1-1/4" | NA/25                   | 5.63                 |
| 401-015     | 1-1/2" | NA/25                   | 7.58                 |
| 401-020     | 2"     | NA/20                   | 11.2                 |
| 401-025     | 2-1/2" | NA/10                   | 10                   |
| 401-030     | 3"     | NA/10                   | 13.74                |
| 401-040     | 4"     | NA/5                    | 13.74                |
| 401-060     | 6"     | NA/4                    | 34.68                |

### REDUCING

|         |                        |        |      |
|---------|------------------------|--------|------|
| 401-095 | 3/4" x 1/2" x 3/4"     | 50/300 | 4    |
| 401-101 | 3/4" x 3/4" x 1/2"     | 50/300 | 3.8  |
| 401-130 | 1" x 1" x 1/2"         | NA/50  | 1.37 |
| 401-131 | 1" x 1" x 3/4"         | NA/50  | 1.49 |
| 401-167 | 1-1/4" x 1-1/4" x 3/4" | NA/25  | 2.2  |
| 401-168 | 1-1/4" x 1-1/4" x 1"   | NA/25  | 2.2  |
| 401-210 | 1-1/2" x 1-1/2" x 3/4" | NA/25  | 3.91 |
| 401-211 | 1-1/2" x 1-1/2" x 1"   | NA/25  | 3.91 |
| 401-251 | 2" x 2" x 1-1/2"       | NA/20  | 3.84 |

**TEE**

**PVC SCHEDULE 40**



**CONNECTION- SLIP x SLIP**

| Part Number | Size   | Inner/Master Carton Qty | Master Weight (lbs.) |
|-------------|--------|-------------------------|----------------------|
| 402-005     | 1/2"   | 50/300                  | 18                   |
| 402-007     | 3/4"   | 50/300                  | 5                    |
| 402-010     | 1"     | NA/50                   | 9                    |
| 402-012     | 1-1/4" | NA/25                   | 6.5                  |
| 402-015     | 1-1/2" | NA/25                   | 9                    |

**REDUCING**

|         |                        |        |      |
|---------|------------------------|--------|------|
| 402-101 | 3/4" x 3/4" x 1/2"     | 50/300 | 4.3  |
| 402-130 | 1" x 1" x 1/2"         | NA/50  | 6    |
| 402-131 | 1" x 1" x 3/4"         | NA/50  | 6.5  |
| 402-166 | 1-1/4" x 1-1/4" x 1/2" | NA/25  | 8    |
| 402-167 | 1-1/4" x 1-1/4" x 3/4" | NA/25  | 5.4  |
| 402-209 | 1-1/2" x 1-1/2" x 1/2" | NA/25  | 7    |
| 402-210 | 1-1/2" x 1-1/2" x 3/4" | NA/25  | 7.44 |
| 402-248 | 2" x 2" x 3/4"         | NA/20  | 4.2  |
| 402-338 | 3" x 3" x 2"           | NA/10  | 11.3 |

**TEE**

**PVC SCHEDULE 40**

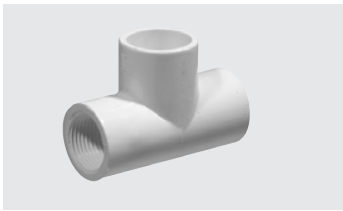

**CONNECTION- SLIP x FPT x SLIP**

| Part Number | Size               | Inner/Master Carton Qty | Master Weight (lbs.) |
|-------------|--------------------|-------------------------|----------------------|
| 403-007     | 3/4" x 3/4" x 3/4" | 50/300                  | 30.54                |

**TEE**

**PVC SCHEDULE 40**



**CONNECTION- FPT x FPT x FPT**

| Part Number | Size | Inner/Master Carton Qty | Master Weight (lbs.) |
|-------------|------|-------------------------|----------------------|
| 405-005     | 1/2" | 50/400                  | 4.5                  |
| 405-007     | 3/4" | 50/300                  | 5.5                  |
| 405-010     | 1"   | NA/50                   | 10                   |

TUBE & PIPE

METAL FITTINGS & NIPPLES

PLASTIC FITTINGS

VALVES

FILTER-DRIERS & STRAINERS



**90° ELBOW****PVC SCHEDULE 40****CONNECTION- SLIP x SLIP**

| Part Number     | Size        | Inner/Master Carton Qty | Master Weight (lbs.) |
|-----------------|-------------|-------------------------|----------------------|
| 406-005         | 1/2"        | 50/600                  | 18.8                 |
| 406-007         | 3/4"        | 50/400                  | 22.2                 |
| 406-010         | 1"          | NA/50                   | 5.9                  |
| 406-012         | 1-1/4"      | NA/25                   | 4.5                  |
| 406-015         | 1-1/2"      | NA/25                   | 6.0                  |
| 406-020         | 2"          | NA/25                   | 9.3                  |
| 406-025         | 2-1/2"      | NA/10                   | 7.7                  |
| 406-030         | 3"          | NA/10                   | 11                   |
| 406-040         | 4"          | NA/5                    | 14.3                 |
| 406-060         | 6"          | NA/5                    | 32                   |
| <b>REDUCING</b> |             |                         |                      |
| 406-101         | 3/4" x 1/2" | 50/400                  | 2.85                 |
| 406-130         | 1" x 1/2"   | NA/50                   | 4.33                 |
| 406-131         | 1" x 3/4"   | NA/50                   | 5                    |
| 406-168         | 1-1/4" x 1" | NA/25                   | 3.8                  |

**90° ELBOW****PVC SCHEDULE 40****CONNECTION- SLIP x FPT**

| Part Number     | Size        | Inner/Master Carton Qty | Master Weight (lbs.) |
|-----------------|-------------|-------------------------|----------------------|
| 407-005         | 1/2"        | 50/600                  | 20                   |
| 407-007         | 3/4"        | 50/400                  | 24                   |
| 407-010         | 1"          | NA/50                   | 9.5                  |
| 407-012         | 1-1/4"      | NA/25                   | 7.5                  |
| 407-015         | 1-1/2"      | NA/25                   | 9.75                 |
| 407-020         | 2"          | NA/25                   | 3.7                  |
| <b>REDUCING</b> |             |                         |                      |
| 407-101         | 3/4" x 1/2" | 50/400                  | 21                   |
| 407-130         | 1" x 1/2"   | NA/50                   | 5                    |
| 407-131         | 1" x 3/4"   | NA/50                   | 5.5                  |
| 407-251         | 2" x 1-1/2" | NA/20                   | 7.5                  |

**90° ELBOW****PVC SCHEDULE 40****CONNECTION- FPT x FPT**

| Part Number | Size | Inner/Master Carton Qty | Master Weight (lbs.) |
|-------------|------|-------------------------|----------------------|
| 408-005     | 1/2" | 50/600                  | 28                   |
| 408-007     | 3/4" | 50/400                  | 4.5                  |

**90° ELBOW • STREET**

**PVC SCHEDULE 40**



**CONNECTION- SLIP x SP**

| Part Number | Size   | Inner/Master Carton Qty | Master Weight (lbs.) |
|-------------|--------|-------------------------|----------------------|
| 409-005     | 1/2"   | 50/600                  | 16                   |
| 409-007     | 3/4"   | 50/400                  | 5                    |
| 409-010     | 1"     | NA/50                   | 5.5                  |
| 409-012     | 1-1/4" | NA/25                   | 5                    |
| 409-015     | 1-1/2" | NA/25                   | 6.5                  |
| 409-020     | 2"     | NA/20                   | 3.8                  |

**90° ELBOW • STREET**

**PVC SCHEDULE 40**



**CONNECTION- SLIP x MTP**

| Part Number | Size   | Inner/Master Carton Qty | Master Weight (lbs.) |
|-------------|--------|-------------------------|----------------------|
| 410-005     | 1/2"   | 50/600                  | 16                   |
| 410-007     | 3/4"   | 50/400                  | 5                    |
| 410-010     | 1"     | NA/50                   | 5.5                  |
| 410-012     | 1-1/4" | NA/25                   | 5                    |
| 410-015     | 1-1/2" | NA/25                   | 6.5                  |
| 410-020     | 2"     | NA/20                   | 3.6                  |

**90° ELBOW • STREET**

**PVC SCHEDULE 40**



**CONNECTION- MIPT x FIPT**

| Part Number | Size | Inner/Master Carton Qty | Master Weight (lbs.) |
|-------------|------|-------------------------|----------------------|
| 412-005     | 1/2" | 50/600                  | 19.6                 |
| 412-007     | 3/4" | 50/400                  | 5.25                 |
| 412-010     | 1"   | 50/300                  | 8.45                 |

**90° ELBOW**

**PVC SCHEDULE 40**



**CONNECTION- MIPT x FIPT**

| Part Number | Size               | Inner/Master Carton Qty | Master Weight (lbs.) |
|-------------|--------------------|-------------------------|----------------------|
| 414-005     | 1/2"               | NA/50                   | 3                    |
| 414-101     | 3/4" x 3/4" x 1/2" | NA/50                   | 4                    |
| 414-130     | 1" x 1" x 1/2"     | NA/50                   | 6.4                  |

TUBE & PIPE

METAL FITTINGS & NIPPLES

PLASTIC FITTINGS

VALVES

FILTER-DRIERS & STRAINERS



**45° ELBOW****PVC SCHEDULE 40****CONNECTION- SLIP x SLIP**

| Part Number | Size   | Inner/Master Carton Qty | Master Weight (lbs.) |
|-------------|--------|-------------------------|----------------------|
| 417-005     | 1/2"   | 50/600                  | 15.2                 |
| 417-007     | 3/4"   | 50/400                  | 17.4                 |
| 417-010     | 1"     | NA/50                   | 4.35                 |
| 417-012     | 1-1/4" | 25/150                  | 3.15                 |
| 417-015     | 1-1/2" | NA/25                   | 4.35                 |
| 417-020     | 2"     | NA/20                   | 6.75                 |
| 417-025     | 2-1/2" | NA/10                   | 5.9                  |
| 417-030     | 3"     | NA/10                   | 8.6                  |
| 417-040     | 4"     | NA/5                    | 6.6                  |
| 417-060     | 6"     | NA/5                    | 40                   |

**CROSS****PVC SCHEDULE 40****CONNECTION- SLIP x SLIP x SLIP x SLIP**

| Part Number | Size   | Inner/Master Carton Qty | Master Weight (lbs.) |
|-------------|--------|-------------------------|----------------------|
| 420-005*    | 1/2"   | 50/300                  | 4                    |
| 420-007*    | 3/4"   | NA/50                   | 5                    |
| 420-010*    | 1"     | NA/50                   | 9.5                  |
| 420-012*    | 1-1/4" | NA/25                   | 11                   |
| 420-015*    | 1-1/2" | NA/25                   | 11                   |
| 420-020*    | 2"     | NA/10                   | 6.5                  |

**COUPLING****PVC SCHEDULE 40****CONNECTION- SLIP x SLIP**

| Part Number     | Size        | Inner/Master Carton Qty | Master Weight (lbs.) |
|-----------------|-------------|-------------------------|----------------------|
| 429-005         | 1/2"        | 50/400                  | 17.4                 |
| 429-007         | 3/4"        | 50/600                  | 18.4                 |
| 429-010         | 1"          | 50/300                  | 3.35                 |
| 429-012         | 1-1/4"      | 25/200                  | 14.55                |
| 429-015         | 1-1/2"      | 25/150                  | 3.25                 |
| 429-020         | 2"          | NA/20                   | 4.65                 |
| 429-025         | 2-1/2"      | NA/10                   | 4.9                  |
| 429-030         | 3"          | NA/15                   | 6.3                  |
| 429-040         | 4"          | NA/5                    | 6.84                 |
| 429-060         | 6"          | NA/5                    | 10.36                |
| <b>REDUCING</b> |             |                         |                      |
| 429-101         | 3/4" x 1/2" | 50/600                  | 27                   |
| 429-131         | 1" x 3/4"   | 50/200                  | 13.6                 |
| 429-338         | 3" x 2"     | 5/30                    | 15.4                 |
| 429-422         | 4" x 3"     | NA/4                    | 4.84                 |

## COUPLING • THREADED

## PVC SCHEDULE 40



### CONNECTION- FTP x FTP

| Part Number | Size | Inner/Master Carton Qty | Master Weight (lbs.) |
|-------------|------|-------------------------|----------------------|
| 430-005     | 1/2" | 50/400                  | 24                   |
| 430-007     | 3/4" | 50/600                  | 24                   |
| 430-010     | 1"   | 50/300                  | 4.5                  |

## RISER • EXTENDER

## PVC SCHEDULE 40



### CONNECTION- FTP x MTP

| Part Number | Size | Inner/Master Carton Qty | Master Weight (lbs.) |
|-------------|------|-------------------------|----------------------|
| 434-005     | 1/2" | 50/400                  | 15.9                 |

## ADAPTER • FEMALE

## PVC SCHEDULE 40



### CONNECTION- SLIP x FTP

| Part Number                 | Size        | Inner/Master Carton Qty | Master Weight (lbs.) |
|-----------------------------|-------------|-------------------------|----------------------|
| 435-005                     | 1/2"        | 50/400                  | 18                   |
| 435-007                     | 3/4"        | 50/600                  | 18.8                 |
| 435-010                     | 1"          | 50/300                  | 4                    |
| 435-012                     | 1-1/4"      | 25/200                  | 2.63                 |
| 435-015                     | 1-1/2"      | 25/150                  | 3.4                  |
| 435-020                     | 2"          | —/20                    | 1.81                 |
| <b>SLIP x REDUCING FPT</b>  |             |                         |                      |
| 435-101                     | 3/4" x 1/2" | 50/600                  | 24                   |
| 435-131                     | 3/4" x 3/4" | 50/200                  | 3.5                  |
| <b>SLIP x REDUCING SLIP</b> |             |                         |                      |
| 435-074                     | 3/4" x 1/2" | 50/600                  | 22.4                 |
| 435-102                     | 1" x 3/4"   | 50/200                  | 3.5                  |

TUBE & PIPE

METAL FITTINGS & NIPPLES

PLASTIC FITTINGS

VALVES

FILTER-DRIERS & STRAINERS



## ADAPTER • MALE

## PVC SCHEDULE 40



## CONNECTION- SLIP x MPT

| Part Number | Size   | Inner/Master Carton Qty | Master Weight (lbs.) |
|-------------|--------|-------------------------|----------------------|
| 436-005     | 1/2"   | 50/800                  | 7.8                  |
| 436-007     | 3/4"   | 50/600                  | 16.8                 |
| 436-010     | 1"     | 50/400                  | 19.8                 |
| 436-012     | 1-1/4" | 25/200                  | 2.48                 |
| 436-015     | 1-1/2" | 25/150                  | 2.18                 |
| 436-020     | 2"     | 10/120                  | 4.34                 |

## SLIP x REDUCING MPT

|         |                 |        |      |
|---------|-----------------|--------|------|
| 436-074 | 3/4" x 1/2"     | 50/600 | 8    |
| 436-102 | 1" x 3/4"       | 50/400 | 3.5  |
| 436-132 | 1-1/4" x 1"     | 25/200 | 5.   |
| 436-169 | 1-1/2" x 1-1/4" | 25/150 | 20.3 |
| 436-213 | 2" x 1-1/2"     | 10/120 | 4.75 |

## MPT x REDUCING SLIP

|         |                 |        |      |
|---------|-----------------|--------|------|
| 436-101 | 3/4" x 1/2"     | 50/400 | 9    |
| 436-131 | 1" x 3/4"       | 50/400 | 2.4  |
| 436-212 | 1-1/2" x 1-1/4" | 25/200 | 3    |
| 436-251 | 2" x 1-1/2"     | 10/120 | 14.4 |

## BUSHING

## PVC SCHEDULE 40



## CONNECTION- SLIP x SLIP

| Part Number | Size            | Inner/Master Carton Qty | Master Weight (lbs.) |
|-------------|-----------------|-------------------------|----------------------|
| 437-101     | 3/4" x 1/2"     | 50/400                  | 6.3                  |
| 437-130     | 1" x 1/2"       | 50/800                  | 9.2                  |
| 437-131     | 1" x 3/4"       | 50/800                  | 6.6                  |
| 437-166     | 1-1/4" x 1/2"   | 25/200                  | 18                   |
| 437-167     | 1-1/4" x 3/4"   | 25/200                  | 23.4                 |
| 437-168     | 1-1/4" x 1"     | 25/200                  | 18.3                 |
| 437-209     | 1-1/2" x 1/2"   | 25/300                  | 28                   |
| 437-210     | 1-1/2" x 3/4"   | 25/300                  | 21                   |
| 437-211     | 1-1/2" x 1"     | 25/300                  | 22                   |
| 437-212     | 1-1/2" x 1-1/4" | 25/300                  | 12.6                 |
| 437-248     | 2" x 3/4"       | 10/160                  | 12.8                 |
| 437-249     | 2" x 1"         | 10/160                  | 12.32                |
| 437-250     | 2" x 1-1/4"     | 10/160                  | 12.48                |
| 437-251     | 2" x 1-1/2"     | 10/160                  | 3.25                 |
| 437-290     | 2-1/2" x 1-1/4" | 10/80                   | 4.6                  |
| 437-291     | 2-1/2" x 1-1/2" | 10/80                   | 3.7                  |
| 437-292     | 2-1/2" x 2"     | 10/80                   | 2.5                  |
| 437-338     | 3" x 2"         | 10/60                   | 4.7                  |
| 437-339     | 3" x 2-1/2"     | 10/60                   | 4.1                  |

## BUSHING

## PVC SCHEDULE 40



### CONNECTION- FTP x SPIG

| Part Number | Size            | Inner/Master Carton Qty | Master Weight (lbs.) |
|-------------|-----------------|-------------------------|----------------------|
| 438-101     | 3/4" x 1/2"     | 50/400                  | 7.2                  |
| 438-130     | 1" x 1/2"       | 50/800                  | 10.2                 |
| 438-131     | 1" x 3/4"       | 50/800                  | 8                    |
| 438-166     | 1-1/4" x 1/2"   | 25/200                  | 11                   |
| 438-167     | 1-1/4" x 3/4"   | 25/200                  | 9                    |
| 438-168     | 1-1/4" x 1"     | 25/200                  | 7                    |
| 438-209     | 1-1/2" x 1/2"   | 25/300                  | 11                   |
| 438-210     | 1-1/2" x 3/4"   | 25/300                  | 12                   |
| 438-211     | 1-1/2" x 1"     | 25/300                  | 11.8                 |
| 438-212     | 1-1/2" x 1-1/4" | 25/300                  | 8                    |
| 438-247     | 2" x 1/2"       | 10/160                  | 13.6                 |
| 438-248     | 2" x 3/4"       | 10/160                  | 14.4                 |
| 438-249     | 2" x 1"         | 10/160                  | 17.6                 |
| 438-250     | 2" x 1-1/4"     | 10/160                  | 16                   |
| 438-251     | 2" x 1-1/2"     | 10/160                  | 12                   |
| 438-290     | 2-1/2" x 1-1/4" | 10/80                   | 4.8                  |
| 438-292     | 2-1/2" x 2"     | 10/80                   | 2.6                  |
| 438-338     | 3" x 2"         | 10/60                   | 4.7                  |
| 438-339     | 3" x 2-1/2"     | 10/60                   | 4.2                  |
| 438-421     | 4" x 2-1/2"     | 5/30                    | 6.24                 |
| 438-422     | 4" x 3"         | 5/30                    | 4.86                 |

## BUSHING

## PVC SCHEDULE 40



### CONNECTION- FTP x MTP

| Part Number | Size            | Inner/Master Carton Qty | Master Weight (lbs.) |
|-------------|-----------------|-------------------------|----------------------|
| 439-101     | 3/4" x 1/2"     | 50/400                  | 18                   |
| 439-130     | 1" x 1/2"       | 50/800                  | 16                   |
| 439-131     | 1" x 3/4"       | 50/800                  | 16                   |
| 439-167     | 1-1/4" x 3/4"   | 25/200                  | 16.8                 |
| 439-168     | 1-1/4" x 1"     | 25/200                  | 10.5                 |
| 439-210     | 1-1/2" x 3/4"   | 25/200                  | 14                   |
| 439-211     | 1-1/2" x 1"     | 25/200                  | 12                   |
| 439-212     | 1-1/2" x 1-1/4" | 25/200                  | 7                    |
| 439-249     | 2" x 1"         | 10/160                  | 23                   |
| 439-251     | 2" x 1-1/2"     | 10/120                  | 15.6                 |

## CAP

## PVC SCHEDULE 40



### CONNECTION- SLIP

| Part Number | Size   | Inner/Master Carton Qty | Master Weight (lbs.) |
|-------------|--------|-------------------------|----------------------|
| 447-005     | 1/2"   | 50/400                  | 6.3                  |
| 447-007     | 3/4"   | 50/400                  | 9.9                  |
| 447-010     | 1"     | 50/400                  | 9.2                  |
| 447-012     | 1-1/4" | 25/300                  | 7                    |
| 447-015     | 1-1/2" | 25/200                  | 2.6                  |
| 447-020     | 2"     | 10/120                  | 12                   |



**CAP continued****PVC SCHEDULE 40****CONNECTION- SLIP**

| Part Number | Size   | Inner/Master Carton Qty | Master Weight (lbs.) |
|-------------|--------|-------------------------|----------------------|
| 447-025     | 2-1/2" | 10/60                   | 3.7                  |
| 447-030     | 3"     | 10/60                   | 5.8                  |
| 447-040     | 4"     | NA/5                    | 4.1                  |
| 447-060     | 6"     | NA/5                    | 16                   |

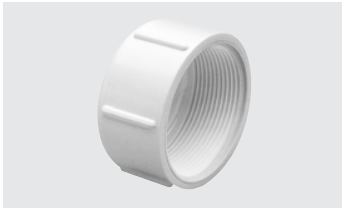
**CAP****PVC SCHEDULE 40****CONNECTION- FTP**

| Part Number | Size   | Inner/Master Carton Qty | Master Weight (lbs.) |
|-------------|--------|-------------------------|----------------------|
| 448-005     | 1/2"   | 50/400                  | 6                    |
| 448-007     | 3/4"   | 50/400                  | 9                    |
| 448-010     | 1"     | 50/400                  | 12                   |
| 448-012     | 1-1/4" | 25/300                  | 11                   |
| 448-015     | 1-1/2" | 25/200                  | 14                   |
| 448-020     | 2"     | 10/120                  | 2.1                  |

**PLUG****PVC SCHEDULE 40****CONNECTION- SPIG**

| Part Number | Size   | Inner/Master Carton Qty | Master Weight (lbs.) |
|-------------|--------|-------------------------|----------------------|
| 449-005     | 1/2"   | 50/400                  | 6                    |
| 449-007     | 3/4"   | 50/400                  | 9                    |
| 449-010     | 1"     | 50/800                  | 10                   |
| 449-012     | 1-1/4" | 25/200                  | 9                    |
| 449-015     | 1-1/2" | 25/300                  | 10                   |
| 449-020     | 2"     | 10/160                  | 20                   |

**PLUG • THREADED****PVC SCHEDULE 40****CONNECTION- MPT**

| Part Number | Size   | Inner/Master Carton Qty | Master Weight (lbs.) |
|-------------|--------|-------------------------|----------------------|
| 450-005     | 1/2"   | 50/400                  | 6                    |
| 450-007     | 3/4"   | 50/400                  | 6                    |
| 450-010     | 1"     | 50/800                  | 16                   |
| 450-012     | 1-1/4" | 25/200                  | 15                   |
| 450-015     | 1-1/2" | 25/200                  | 9                    |
| 450-020     | 2"     | 10/160                  | 16.8                 |

**UNION • WITH BUNA O-RING**

**PVC SCHEDULE 40**



**CONNECTION- S x S**

| Part Number | Size | Inner/Master Carton Qty | Master Weight (lbs.) |
|-------------|------|-------------------------|----------------------|
| 457-007*    | 3/4" | 10/80                   | 45.8                 |

**COUPLING • DEEP SOCKET**

**PVC SCHEDULE 40**

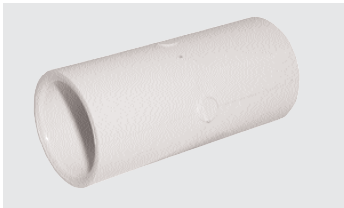

**CONNECTION- SLIP**

| Part Number | Size | Inner/Master Carton Qty | Master Weight (lbs.) |
|-------------|------|-------------------------|----------------------|
| 482-007     | 3/4" | NA/50                   | 2.31                 |

**R-TRAP • CONDENSATE DRAIN LINE**

**PVC SCHEDULE 40**



**CONNECTION- SP x SP**

| Part Number | Size | Inner/Master Carton Qty | Master Weight (lbs.) |
|-------------|------|-------------------------|----------------------|
| 488-005     | 1/2" | NA/50                   | 6.                   |
| 488-007     | 3/4" | NA/50                   | 12                   |
| 488-010     | 1"   | NA/10                   | 4                    |

**P-TRAP • CONDENSATE DRAIN LINE**

**PVC SCHEDULE 40**



\*315PSI

**CONNECTION- SP x SP**

| Part Number | Size | Inner/Master Carton Qty | Master Weight (lbs.) |
|-------------|------|-------------------------|----------------------|
| 489-007     | 3/4" | NA/50                   | 12                   |
| 489-005*    | 1/2" | NA/50                   | 6                    |
| 489-010     | 1"   | NA/10                   | 4                    |

TUBE & PIPE

METAL FITTINGS & NIPPLES

PLASTIC FITTINGS

VALVES

FILTER-DRIERS & STRAINERS



# Insert Fittings



Mueller offers a variety of insert fittings in four different materials; PVC, Nylon, Polypropylene and Steel. These insert fittings are designed to be used in conjunction with clamps and compression fittings for the connection of flexible polyethylene plastic tubing and hosing. Just as with polyethylene tubing, these fittings are for cold water applications only. Polyethylene plastic tubing comes in long coils, requires support every 32 inches and is often subject to kinking if bent too far. Utilizing reliable Mueller Insert Fittings helps to ease the installation of flexible tubing or hosing systems. When the job requires a variety of insert fittings for polyethylene tubing, think Mueller!



TUBE & PIPE

METAL FITTINGS & NIPPLES

PLASTIC FITTINGS

VALVES

FILTER-DRIERS & STRAINERS

## ADAPTER

## INSERT



\*Furnished in either polypropylene or PVC material, whichever is available at time of shipment.

### CONNECTION- MIP x MIPT

| Part Number | Size   | Inner/Master Carton Qty | Master Weight (lbs.) |
|-------------|--------|-------------------------|----------------------|
| 04784       | 1/2"   | 25/900                  | .02                  |
| 04785       | 3/4"   | 15/360                  | .03                  |
| 04786       | 1"     | 10/260                  | .05                  |
| 04787*      | 1-1/4" | 10/150                  | .11                  |
| 04788*      | 1-1/2" | 10/10                   | .13                  |
| 04789*      | 2"     | 10/60                   | .17                  |

### REDUCING

|       |        |       |     |
|-------|--------|-------|-----|
| 57562 | 1/2"   | NA/25 | .23 |
| 57559 | 3/4"   | NA/25 | .24 |
| 57561 | 1"     | NA/20 | .41 |
| 57563 | 1-1/4" | NA/20 | .67 |
| 57565 | 1-1/2" | NA/10 | .91 |

## ADAPTER

## INSERT



### CONNECTION- MIP x MIPT

| Part Number | Size   | Inner/Master Carton Qty | Master Weight (lbs.) |
|-------------|--------|-------------------------|----------------------|
| 04180       | 1/2"   | 25/1,200                | .02                  |
| 04181       | 3/4"   | 25/700                  | .02                  |
| 04182       | 1"     | 25/350                  | .04                  |
| 04183       | 1-1/4" | 10/150                  | .06                  |
| 04184       | 1-1/2" | 10/140                  | .08                  |
| 04185       | 2"     | 5/60                    | .13                  |



**ADAPTER continued**

**INSERT**

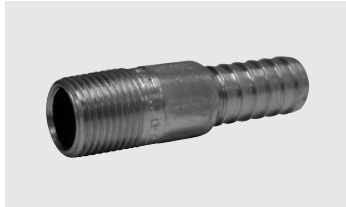

\*Furnished in either polypropylene or PVC material, whichever is available at time of shipment.

**CONNECTION- MIP x MIPT**

| Part Number  | Size            | Inner/Master Carton Qty | Master Weight (lbs.) |
|--------------|-----------------|-------------------------|----------------------|
| 04403*       | 3"              | NA/10                   | .41                  |
| <b>NYLON</b> |                 |                         |                      |
| 04130        | 1/2"            | 25/1,200                | .02                  |
| 04131        | 3/4"            | 25/700                  | .03                  |
| 04132        | 1"              | 25/350                  | .05                  |
| 04133        | 1-1/4"          | 10/150                  | .08                  |
| 04134        | 1-1/2"          | 10/140                  | .10                  |
| 04135        | 2"              | 5/60                    | .18                  |
| <b>STEEL</b> |                 |                         |                      |
| 57541        | 1/2"            | 25/300                  | .14                  |
| 57543        | 3/4"            | 25/200                  | .22                  |
| 57545        | 1"              | 20/160                  | .38                  |
| 57547        | 1-1/4"          | 20/120                  | .55                  |
| 57549        | 1-1/2"          | 10/60                   | .71                  |
| 57551        | 2"              | 10/40                   | .95                  |
| 57556        | 2-1/2"          | NA/1                    | 2.05                 |
| 57558        | 3"              | NA/1                    | 2.61                 |
| 57560        | 4"              | NA/1                    | 4.12                 |
| <b>PVC</b>   |                 |                         |                      |
| 04306*       | 1/2" x 3/4"     | 20/720                  | .03                  |
| 04307*       | 3/4" x 1"       | 10/400                  | .07                  |
| 04308        | 1" x 1-1/4"     | 10/160                  | .08                  |
| 04309*       | 1-1/4" x 1-1/2" | 5/150                   | .08                  |
| 04310*       | 1-1/2" x 2"     | NA/10                   | .12                  |

**ADAPTER**

**INSERT**



**CONNECTION- MIP x MIPT**

| Part Number | Size        | Inner/Master Carton Qty | Master Weight (lbs.) |
|-------------|-------------|-------------------------|----------------------|
| 04313*      | 3/4" x 1/2" | 10/450                  | .04                  |
| 04314*      | 1" x 3/4"   | 10/250                  | .05                  |
| 04315*      | 1-1/4" x 1" | 10/120                  | .07                  |

**BUSHING**

**INSERT**



**CONNECTION- FIP x MIPT**

| Part Number | Size            | Inner/Master Carton Qty | Master Weight (lbs.) |
|-------------|-----------------|-------------------------|----------------------|
| 04202       | 3/4" x 1/2"     | 25/1,200                | .25                  |
| 04203       | 1" x 3/4"       | 25/800                  | .02                  |
| 04204       | 1-1/4" x 1"     | 25/500                  | .25                  |
| 04205       | 1-1/2" x 1-1/4" | 25/450                  | .03                  |
| 04206       | 2" x 1-1/2"     | 10/200                  | .07                  |



## COUPLING

## INSERT



\*Furnished in either polypropylene or PVC material, whichever is available at time of shipment.

\*\*Not listed with NSF.

## CONNECTION- INSERT

| Part Number  | Size     | Inner/Master Carton Qty | Master Weight (lbs.) |
|--------------|----------|-------------------------|----------------------|
| <b>POLY</b>  |          |                         |                      |
| 04170        | 1/2"     | 10/800                  | .02                  |
| 04171        | 3/4"     | 10/450                  | .03                  |
| 04172*       | 1"       | 10/200                  | .05                  |
| 04173*       | **1-1/4" | 10/120                  | .09                  |
| 04174        | 1-1/2"   | 10/100                  | .11                  |
| 04175        | 2"       | 5/60                    | .24                  |
| <b>NYLON</b> |          |                         |                      |
| 04120        | 1/2"     | 10/800                  | .05                  |
| 04121        | 3/4"     | 10/450                  | .08                  |
| 04122**      | 1"       | 10/200                  | .10                  |
| 04123**      | 1-1/4"   | 10/120                  | .17                  |
| 04124        | 1-1/2"   | 10/100                  | .23                  |
| 04125        | 2"       | 5/40                    | .39                  |

## 90° ELBOW

## INSERT



\*Furnished in either polypropylene or PVC material, whichever is available at time of shipment.

## CONNECTION- INSERT

| Part Number      | Size            | Inner/Master Carton Qty | Master Weight (lbs.) |
|------------------|-----------------|-------------------------|----------------------|
| <b>POLY PLUS</b> |                 |                         |                      |
| 04177            | 1/2"            | 10/300                  | .05                  |
| 04179            | 3/4"            | 25/450                  | .08                  |
| 04333*           | 1"              | NA/25                   | .10                  |
| 04337*           | 1-1/4"          | NA/10                   | .17                  |
| 04339*           | 1-1/2"          | NA/10                   | .23                  |
| 04341*           | 2"              | 5/40                    | .39                  |
| <b>NYLON</b>     |                 |                         |                      |
| 04176            | 3/4" x 1/2"     | 10/240                  | .05                  |
| 04331*           | 1" x 1/2"       | 10/180                  | .09                  |
| 04332*           | x 3/4"          | 10/180                  | .09                  |
| 04334*           | 1-1/4" x 1/2"   | NA/25                   | .10                  |
| 04335*           | 1-1/4" x 3/4"   | NA/10                   | .11                  |
| 04336*           | 1-1/4" x 1"     | 5/150                   | .14                  |
| 04338*           | 1-1/2" x 1-1/4" | NA/10                   | .21                  |
| 04340*           | 2" x 1-1/2"     | 5/40                    | .31                  |

## 90° CAP

## INSERT



\*Furnished in either polypropylene or PVC material, whichever is available at time of shipment.

## CONNECTION- INSERT

| Part Number     | Size   | Inner/Master Carton Qty | Master Weight (lbs.) |
|-----------------|--------|-------------------------|----------------------|
| <b>REDUCING</b> |        |                         |                      |
| 04342*          | 1/2"   | 10/600                  | .03                  |
| 04343*          | 3/4"   | 10/400                  | .05                  |
| 04344*          | 1"     | 10/240                  | .07                  |
| 04345*          | 1-1/4" | 5/140                   | .12                  |
| 04346*          | 1-1/2" | 5/75                    | .18                  |
| 04347*          | 2"     | 5/60                    | .30                  |

# ABS DWV Fittings



Mueller's ABS DWV fittings are made to the most exacting specifications to ensure the best fit in the industry. Each fitting offers excellent rigidity, corrosion and chemical resistance while smooth walls prevent scaling and provide for free flow. Our precise manufacturing processes and stringent quality control ensure that our fittings perform flawlessly piece after piece. Fittings are packaged to common industry carton quantities and dimensions plus utilize an intuitive, recognizable style number system.

- Meets ASTM standard D2661 and D3311
- Made in the USA



TUBE & PIPE

METAL FITTINGS & NIPPLES

PLASTIC FITTINGS

VALVES

FILTER-DRIERS & STRAINERS

## COUPLING

## ABS DWV

### A100

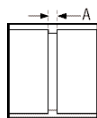
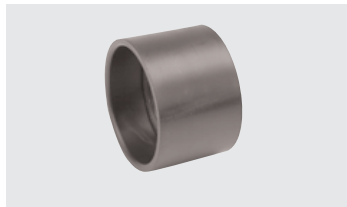

| CONNECTION<br><b>H x H</b> | CHARLOTTE STYLE<br>100 |         | NIBCO STYLE<br>5801 |      | Dimensions |   |   |   |   |  |
|----------------------------|------------------------|---------|---------------------|------|------------|---|---|---|---|--|
|                            | Part Number            | Ctn Qty | Approx Net Wt.      | A    | B          | C | D | E | F |  |
| 1-1/4"                     | 02932                  | 50      | .06                 | 1/8  |            |   |   |   |   |  |
| 1-1/2"                     | 02933                  | 100     | .07                 | 1/8  |            |   |   |   |   |  |
| 2"                         | 02934                  | 100     | .10                 | 1/8  |            |   |   |   |   |  |
| 3"                         | 02935                  | 60      | .33                 | 3/16 |            |   |   |   |   |  |
| 4"                         | 02936                  | 25      | .58                 | 1/4  |            |   |   |   |   |  |
| 6"                         | 03143                  | 15      | 1.45                | 1/4  |            |   |   |   |   |  |

## ADAPTER • FEMALE

## ABS DWV

### A101

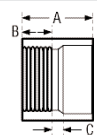
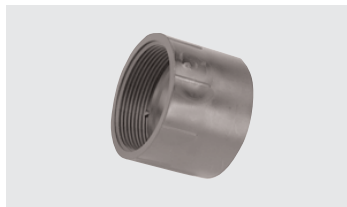

| CONNECTION<br><b>H x FPT</b> | CHARLOTTE STYLE<br>101 |         | NIBCO STYLE<br>5803 |        | Dimensions |       |   |   |   |  |
|------------------------------|------------------------|---------|---------------------|--------|------------|-------|---|---|---|--|
|                              | Part Number            | Ctn Qty | Approx Net Wt.      | A      | B          | C     | D | E | F |  |
| 1-1/4"                       | 03006                  | 50      | .07                 | 1-5/8  | 15/16      | 1/4   |   |   |   |  |
| 1-1/2"                       | 02866                  | 100     | .07                 | 1-5/8  | 15/16      | 1/4   |   |   |   |  |
| 2"                           | 02867                  | 100     | .11                 | 1-7/8  | 1          | 1/4   |   |   |   |  |
| 3"                           | 02869                  | 30      | .37                 | 3-1/32 | 1-27/32    | 5/16  |   |   |   |  |
| 4"                           | 03396                  | 10      | .58                 | 3-3/32 | 1-5/16     | 11/32 |   |   |   |  |
| 6"                           | 03147                  | 10      | 1.40                | 4-3/4  | 1-3/4      | 1/4   |   |   |   |  |



## PIPE INCREASER • REDUCER

ABS DWV

## A102

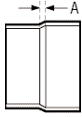
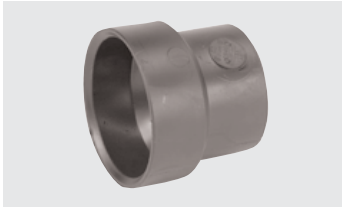

| CONNECTION<br>H x H | CHARLOTTE STYLE<br>102 |            | NIBCO STYLE<br>N/A |            |   |   |   |   |   |
|---------------------|------------------------|------------|--------------------|------------|---|---|---|---|---|
| Size                | Part<br>Number         | Ctn<br>Qty | Approx<br>Net Wt.  | Dimensions |   |   |   |   |   |
|                     |                        |            |                    | A          | B | C | D | E | F |
| 2" x 1-1/2"         | 02948                  | 25         | .11                | 17/32      |   |   |   |   |   |
| 3" x 1-1/2"         | 02949                  | 50         | .30                | 17/16      |   |   |   |   |   |
| 3" x 2"             | 02950                  | 20         | .30                | 7/8        |   |   |   |   |   |
| 4" x 2"             | 02951                  | 10         | .51                | 1-3/8      |   |   |   |   |   |
| 4" x 3"             | 02952                  | 20         | .58                | 5/8        |   |   |   |   |   |

## TRAP ADAPTER • MALE • W/ONE-PIECE POLY NUT

ABS DWV

## A103P

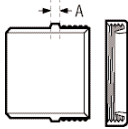

| CONNECTION<br>SP x SJ | CHARLOTTE STYLE<br>103-P |            | NIBCO STYLE<br>N/A |            |   |   |   |   |   |
|-----------------------|--------------------------|------------|--------------------|------------|---|---|---|---|---|
| Size                  | Part<br>Number           | Ctn<br>Qty | Approx<br>Net Wt.  | Dimensions |   |   |   |   |   |
|                       |                          |            |                    | A          | B | C | D | E | F |
| 1-1/4"                | 03391                    | 50         | .08                | 3/16       |   |   |   |   |   |
| 1-1/2"                | 03393                    | 50         | .09                | 3/16       |   |   |   |   |   |
| 1-1/2" x 1-1/4"       | 03379                    | 75         | .09                | 3/16       |   |   |   |   |   |

## TRAP ADAPTER • MALE • W/PLASTIC NUT &amp; 1-1/2" &amp; 1-1/4" WASHERS

ABS DWV

## A103R

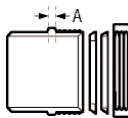

| CONNECTION<br>SP x SJ | CHARLOTTE STYLE<br>N/A |            | NIBCO STYLE<br>N/A |            |   |   |   |   |   |
|-----------------------|------------------------|------------|--------------------|------------|---|---|---|---|---|
| Size                  | Part<br>Number         | Ctn<br>Qty | Approx<br>Net Wt.  | Dimensions |   |   |   |   |   |
|                       |                        |            |                    | A          | B | C | D | E | F |
| 1-1/2" x 1-1/4"       | 03389                  | 50         | .10                | 3/16       |   |   |   |   |   |
| OR<br>1-1/2"          | 03389                  | 50         | .10                | 3/16       |   |   |   |   |   |

**TRAP ADAPTER • MALE • W/PLASTIC NUT & WASHER**

**ABS DWV**

**A103W**

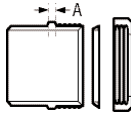

| CONNECTION<br><b>SP x SJ</b> | CHARLOTTE STYLE |         |                | NIBCO STYLE |   |   | Dimensions |   |   |  |  |  |
|------------------------------|-----------------|---------|----------------|-------------|---|---|------------|---|---|--|--|--|
|                              | Part Number     | Ctn Qty | Approx Net Wt. | A           | B | C | D          | E | F |  |  |  |
|                              | N/A             |         |                | 5801-2-7    |   |   |            |   |   |  |  |  |
| Size                         |                 |         |                |             |   |   |            |   |   |  |  |  |
| 1-1/4"                       | 03308           | 50      | .08            | 3/16        |   |   |            |   |   |  |  |  |
| 1-1/2"                       | 03410           | 50      | .09            | 3/16        |   |   |            |   |   |  |  |  |
| 2"                           | 03390           | 25      | .12            | 3/16        |   |   |            |   |   |  |  |  |
| 1-1/2" x 1-1/4"              | 03409           | 50      | .09            | 3/16        |   |   |            |   |   |  |  |  |

**TRAP ADAPTER • MALE • W/CHROME NUT & WASHER**

**ABS DWV**

**A103X**

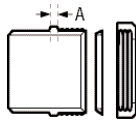

| CONNECTION<br><b>SP x SJ</b> | CHARLOTTE STYLE |         |                | NIBCO STYLE |   |   | Dimensions |   |   |  |  |  |
|------------------------------|-----------------|---------|----------------|-------------|---|---|------------|---|---|--|--|--|
|                              | Part Number     | Ctn Qty | Approx Net Wt. | A           | B | C | D          | E | F |  |  |  |
|                              | 103X            |         |                | 5801-2-7-C  |   |   |            |   |   |  |  |  |
| Size                         |                 |         |                |             |   |   |            |   |   |  |  |  |
| 1-1/4"                       | 03309           | 50      | .14            | 3/16        |   |   |            |   |   |  |  |  |
| 1-1/2"                       | 03392           | 50      | .15            | 3/16        |   |   |            |   |   |  |  |  |
| 1-1/2" x 1-1/4"              | 03378           | 100     | .13            | 3/16        |   |   |            |   |   |  |  |  |

**TRAP ADAPTER • FEMALE • W/ONE-PIECE POLY NUT**

**ABS DWV**

**A104P**

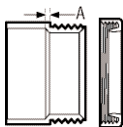

| CONNECTION<br><b>H x SJ</b> | CHARLOTTE STYLE |         |                | NIBCO STYLE |   |   | Dimensions |   |   |  |  |  |
|-----------------------------|-----------------|---------|----------------|-------------|---|---|------------|---|---|--|--|--|
|                             | Part Number     | Ctn Qty | Approx Net Wt. | A           | B | C | D          | E | F |  |  |  |
|                             | 104-P           |         |                | N/A         |   |   |            |   |   |  |  |  |
| Size                        |                 |         |                |             |   |   |            |   |   |  |  |  |
| 1-1/4"                      | 03381           | 50      | .08            | 3/16        |   |   |            |   |   |  |  |  |
| 1-1/2"                      | 03377           | 50      | .09            | 3/16        |   |   |            |   |   |  |  |  |
| 1-1/2" x 1-1/4"             | 03395           | 50      | .11            | 3/16        |   |   |            |   |   |  |  |  |

**TRAP ADAPTER • FEMALE • W/PLASTIC NUT & WASHER**

**ABS DWV**

**A104W**

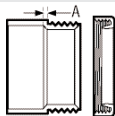

| CONNECTION<br><b>H x SJ</b> | CHARLOTTE STYLE |         |                | NIBCO STYLE |   |   | Dimensions |   |   |  |  |  |
|-----------------------------|-----------------|---------|----------------|-------------|---|---|------------|---|---|--|--|--|
|                             | Part Number     | Ctn Qty | Approx Net Wt. | A           | B | C | D          | E | F |  |  |  |
|                             | N/A             |         |                | 5801-7      |   |   |            |   |   |  |  |  |
| Size                        |                 |         |                |             |   |   |            |   |   |  |  |  |
| 1-1/4"                      | 03380           | 50      | .11            | 3/16        |   |   |            |   |   |  |  |  |
| 1-1/2"                      | 03383           | 50      | .09            | 3/16        |   |   |            |   |   |  |  |  |
| 2"                          | 03382           | 25      | .13            | 3/16        |   |   |            |   |   |  |  |  |
| 1-1/2" x 1-1/4"             | 03384           | 50      | .10            | 3/16        |   |   |            |   |   |  |  |  |



## TRAP ADAPTER • FEMALE W/CHROME NUT &amp; WASHER

ABS DWV

## A104X

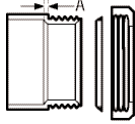

| CONNECTION<br>H x S <sub>J</sub> | CHARLOTTE STYLE<br>104-X | NIBCO STYLE<br>5801-7-C |                   | Dimensions |   |   |   |   |   |
|----------------------------------|--------------------------|-------------------------|-------------------|------------|---|---|---|---|---|
| Size                             | Part<br>Number           | Ctn<br>Qty              | Approx<br>Net Wt. | A          | B | C | D | E | F |
| 1-1/2"                           | 03376                    | 50                      | .15               | 3/16       |   |   |   |   |   |
| 2"                               | 03397                    | 25                      | .21               | 3/16       |   |   |   |   |   |
| 1-1/2" x 1-1/4"                  | 03394                    | 50                      | .13               | 3/16       |   |   |   |   |   |

## ADAPTER • CLEANOUT

ABS DWV

## A105

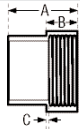

| CONNECTION<br>SP x FPT | CHARLOTTE STYLE<br>105 | NIBCO STYLE<br>5803-2 |                   | Dimensions |         |      |   |   |   |
|------------------------|------------------------|-----------------------|-------------------|------------|---------|------|---|---|---|
| Size                   | Part<br>Number         | Ctn<br>Qty            | Approx<br>Net Wt. | A          | B       | C    | D | E | F |
| 1-1/4"                 | 02921                  | 50                    | .06               | 1-19/32    | 27/32   | 5/32 |   |   |   |
| 1-1/2"                 | 02922                  | 50                    | .07               | 1-5/8      | 7/8     | 5/32 |   |   |   |
| 2"                     | 02923                  | 50                    | .09               | 1-17/32    | 29/32   | 5/32 |   |   |   |
| 3"                     | 02924                  | 25                    | .34               | 2-29/32    | 1-13/64 | 3/16 |   |   |   |
| 4"                     | 02925                  | 10                    | .53               | 3-13/32    | 1-5/16  | 1/4  |   |   |   |
| 6"                     | 03148                  | 10                    | 1.13              | 4-7/8      | 1-7/8   | 3/8  |   |   |   |

## ADAPTER • CLEANOUT • W/CLEANOUT PLUG

ABS DWV

## A105X

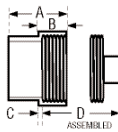

| CONNECTION<br>SP x FPT | CHARLOTTE STYLE<br>105-X | NIBCO STYLE<br>5816 |                   | Dimensions |         |      |         |   |   |
|------------------------|--------------------------|---------------------|-------------------|------------|---------|------|---------|---|---|
| Size                   | Part<br>Number           | Ctn<br>Qty          | Approx<br>Net Wt. | A          | B       | C    | D       | E | F |
| 1-1/2"                 | 03001                    | 50                  | .11               | 1-5/8      | 7/8     | 5/32 | 1-15/32 |   |   |
| 2"                     | 03002                    | 50                  | .15               | 1-17/32    | 29/32   | 5/32 | 1-1/2   |   |   |
| 3"                     | 03003                    | 25                  | .41               | 2-29/32    | 1-13/64 | 3/16 | 2-1/64  |   |   |
| 4"                     | 03004                    | 10                  | .67               | 3-13/32    | 1-5/16  | 1/4  | 2-1/16  |   |   |
| 6"                     | 03005                    | 10                  | 1.81              | 4-7/8      | 1-7/8   | 3/8  | 2-1/2   |   |   |

## PLUG • CLEANOUT

ABS DWV

## A106

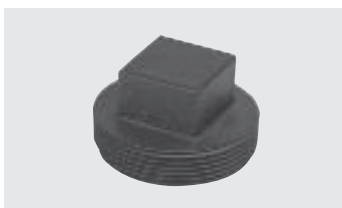

| CONNECTION<br>MPT | CHARLOTTE STYLE<br>106 | NIBCO STYLE<br>5818 |                   | Dimensions |       |   |   |   |   |
|-------------------|------------------------|---------------------|-------------------|------------|-------|---|---|---|---|
| Size              | Part<br>Number         | Ctn<br>Qty          | Approx<br>Net Wt. | A          | B     | C | D | E | F |
| 1-1/2"            | 02938                  | 50                  | .05               | 5/8        | 1-3/8 |   |   |   |   |
| 2"                | 02939                  | 50                  | .07               | 5/8        | 1-3/8 |   |   |   |   |
| 3"                | 02941                  | 25                  | .14               | 3/4        | 1-3/4 |   |   |   |   |
| 3-1/2"            | 02943                  | 30                  | .18               | 3/4        | 1-3/4 |   |   |   |   |
| 4"                | 02942                  | 30                  | .26               | 7/8        | 1-7/8 |   |   |   |   |
| 6"                | 03146                  | 10                  | .54               | 1          | 2     |   |   |   |   |

**PLUG • SLIP**

**ABS DWV**

**A106P**

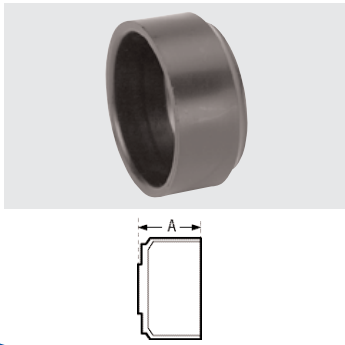

| CONNECTION<br><b>SP</b> | CHARLOTTE STYLE |         |                | NIBCO STYLE |   |   |   |   |   |
|-------------------------|-----------------|---------|----------------|-------------|---|---|---|---|---|
|                         | Part Number     | Ctn Qty | Approx Net Wt. | Dimensions  |   |   |   |   |   |
| Size                    |                 |         |                | A           | B | C | D | E | F |
| 1-1/2"                  | 03055           | 25      | .05            | 1-1/16      |   |   |   |   |   |
| 2"                      | 03056           | 50      | .06            | 1-1/8       |   |   |   |   |   |

**BUSHING • FLUSH**

**ABS DWV**

(STYLE #3)

**A107**

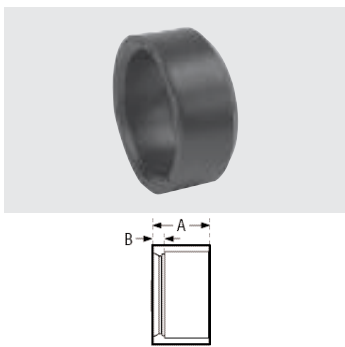

| CONNECTION<br><b>SP x H</b> | CHARLOTTE STYLE |         |                | NIBCO STYLE |      |   |   |   |   |
|-----------------------------|-----------------|---------|----------------|-------------|------|---|---|---|---|
|                             | Part Number     | Ctn Qty | Approx Net Wt. | Dimensions  |      |   |   |   |   |
| Size                        |                 |         |                | A           | B    | C | D | E | F |
| 1-1/2" x 1-1/4"             | 02904           | 100     | .04            | 1           | 3/16 |   |   |   |   |
| 2" x 1-1/4"                 | 02905           | 50      | .10            | 1 1/16      | 5/16 |   |   |   |   |
| 2" x 1-1/2"                 | 02906           | 50      | .08            | 1 1/16      | 5/16 |   |   |   |   |
| 3" x 1-1/2"                 | 02907           | 30      | .26            | 1-1/2       | 7/8  |   |   |   |   |
| 3" x 2"                     | 02908           | 30      | .26            | 1-1/2       | 3/4  |   |   |   |   |
| 4" x 2"                     | 02910           | 30      | .45            | 2           | 1/4  |   |   |   |   |
| 4" x 3"                     | 02909           | 30      | .34            | 1-3/4       | 1/4  |   |   |   |   |

**BUSHING • FLANGE • W/TUBE STOP**

**ABS DWV**

(STYLE #1)

**A107S**

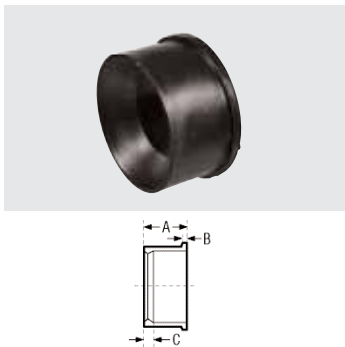

| CONNECTION<br><b>SP x H</b> | CHARLOTTE STYLE |         |                | NIBCO STYLE |     |       |   |   |   |
|-----------------------------|-----------------|---------|----------------|-------------|-----|-------|---|---|---|
|                             | Part Number     | Ctn Qty | Approx Net Wt. | Dimensions  |     |       |   |   |   |
| Size                        |                 |         |                | A           | B   | C     | D | E | F |
| 6" x 4"                     | 03144           | 10      | 1.41           | 3-1/2       | 1/2 | 1-3/4 |   |   |   |

**BUSHING • FLUSH (CLEANOUT ADAPTER)**

**ABS DWV**

(STYLE #3)

**A108**

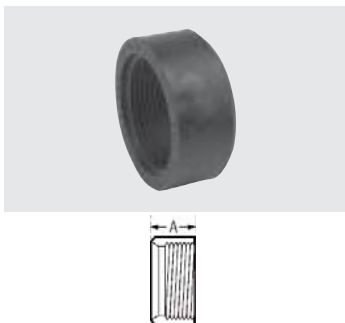

| CONNECTION<br><b>SP x FPT</b> | CHARLOTTE STYLE |         |                | NIBCO STYLE |   |   |   |   |   |
|-------------------------------|-----------------|---------|----------------|-------------|---|---|---|---|---|
|                               | Part Number     | Ctn Qty | Approx Net Wt. | Dimensions  |   |   |   |   |   |
| Size                          |                 |         |                | A           | B | C | D | E | F |
| 1-1/2" x 1-1/4"               | 02912           | 50      | .04            | 1           |   |   |   |   |   |
| 2" x 1-1/2"                   | 02913           | 50      | .08            | 13/32       |   |   |   |   |   |

TUBE & PIPE

METAL FITTINGS & NIPPLES

PLASTIC FITTINGS

VALVES

FILTER-DRYERS & STRAINERS



## ADAPTER • MALE

ABS DWV

## A109

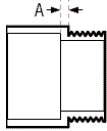
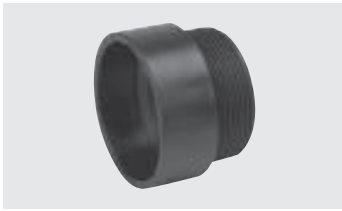
CONNECTION  
**H x MPT**CHARLOTTE STYLE  
109NIBCO STYLE  
5804

| Size            | Part Number | Ctn Qty | Approx Net Wt. | Dimensions |   |   |   |   |   |
|-----------------|-------------|---------|----------------|------------|---|---|---|---|---|
|                 |             |         |                | A          | B | C | D | E | F |
| 1-1/4"          | 02931       | 50      | .05            | 3/16       |   |   |   |   |   |
| 1-1/2"          | 02927       | 50      | .06            | 3/16       |   |   |   |   |   |
| 2"              | 02928       | 50      | .10            | 3/16       |   |   |   |   |   |
| 3"              | 02929       | 25      | .33            | 3/8        |   |   |   |   |   |
| 4"              | 02930       | 10      | .45            | 3/8        |   |   |   |   |   |
| 1-1/2" x 1-1/4" | 02926       | 25      | .07            | 3/16       |   |   |   |   |   |

## ADAPTER • MALE

ABS DWV

## A111

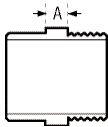
CONNECTION  
**SP x MPT**CHARLOTTE STYLE  
111NIBCO STYLE  
5804-2

| Size   | Part Number | Ctn Qty | Approx Net Wt. | Dimensions |   |   |   |   |   |
|--------|-------------|---------|----------------|------------|---|---|---|---|---|
|        |             |         |                | A          | B | C | D | E | F |
| 1-1/4" | 03010       | 50      | .06            | 5/32       |   |   |   |   |   |
| 1-1/2" | 03386       | 50      | .07            | 5/32       |   |   |   |   |   |
| 2"     | 03385       | 25      | .08            | 5/32       |   |   |   |   |   |
| 3"     | 03366       | 25      | .28            | 3/8        |   |   |   |   |   |

**REDUCING**

|                 |       |     |     |      |  |  |  |  |  |
|-----------------|-------|-----|-----|------|--|--|--|--|--|
| 1-1/2" x 1-1/4" | 03387 | 100 | .07 | 5/16 |  |  |  |  |  |
|-----------------|-------|-----|-----|------|--|--|--|--|--|

## ADAPTER • TRAY PLUG

ABS DWV

## A113

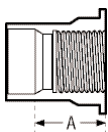
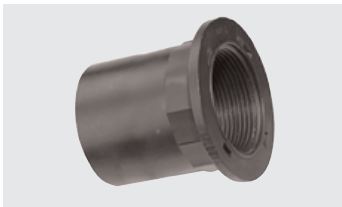
CONNECTION  
**H x NPSM Threaded**CHARLOTTE STYLE  
N/ANIBCO STYLE  
5803-TPA

| Size   | Part Number | Ctn Qty | Approx Net Wt. | Dimensions |   |   |   |   |   |
|--------|-------------|---------|----------------|------------|---|---|---|---|---|
|        |             |         |                | A          | B | C | D | E | F |
| 1-1/2" | 03014       | 50      | .15            | 1-7/8      |   |   |   |   |   |

**ADAPTER • TRAY PLUG • SPIGOT**

**ABS DWV**

**A113S**

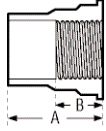

| Size   | Part Number | Ctn Qty | Approx Net Wt. | Dimensions |        |   |   |   |   |  |
|--------|-------------|---------|----------------|------------|--------|---|---|---|---|--|
|        |             |         |                | A          | B      | C | D | E | F |  |
| 1-1/2" | 03419       | 50      | .15            | 3-3/8      | 1-9/16 |   |   |   |   |  |

CONNECTION **SP x NPSM Threaded**      CHARLOTTE STYLE N/A      NIBCO STYLE 5803-2-TPA

**CAP • THREADED**

**ABS DWV**

**A114**

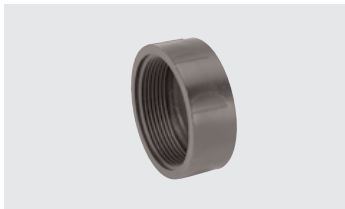

| Size   | Part Number | Ctn Qty | Approx Net Wt. | Dimensions |   |   |   |   |   |  |
|--------|-------------|---------|----------------|------------|---|---|---|---|---|--|
|        |             |         |                | A          | B | C | D | E | F |  |
| 1-1/2" | 02993       | 100     | .06            | 7/8        |   |   |   |   |   |  |
| 2"     | 02994       | 50      | .09            | 7/8        |   |   |   |   |   |  |
| 3"     | 02995       | 25      | .27            | 1-3/8      |   |   |   |   |   |  |

CONNECTION **FPT**      CHARLOTTE STYLE 114      NIBCO STYLE 5827

**CAP • SOCKET**

**ABS DWV**

**A116**

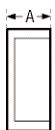

| Size   | Part Number | Ctn Qty | Approx Net Wt. | Dimensions |   |   |   |   |   |  |
|--------|-------------|---------|----------------|------------|---|---|---|---|---|--|
|        |             |         |                | A          | B | C | D | E | F |  |
| 1-1/2" | 02977       | 50      | .06            | 1-1/16     |   |   |   |   |   |  |
| 2"     | 02978       | 50      | .09            | 1-3/16     |   |   |   |   |   |  |
| 3"     | 02979       | 25      | .28            | 2-1/4      |   |   |   |   |   |  |
| 4"     | 02980       | 5       | .52            | 2-5/16     |   |   |   |   |   |  |

CONNECTION **H**      CHARLOTTE STYLE 116      NIBCO STYLE 5817

TUBE & PIPE

METAL FITTINGS & NIPPLES

PLASTIC FITTINGS

VALVES

FILTER-DRIERS & STRAINERS



**ADAPTER • COUPLING****ABS DWV**

(Adapts Sewer &amp; Drain Pipe To DWV Pipe)

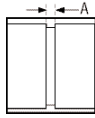
**A117**CONNECTION  
**S/D H x DWV H**CHARLOTTE STYLE  
117NIBCO STYLE  
5800-SD

| Size    | Part Number | Ctn Qty | Approx Net Wt. | Dimensions |   |   |   |   |   |
|---------|-------------|---------|----------------|------------|---|---|---|---|---|
|         |             |         |                | A          | B | C | D | E | F |
| 3"      | 02970       | 10      | .44            | 1/8        |   |   |   |   |   |
| 4"      | 02963       | 10      | .43            | 1/4        |   |   |   |   |   |
| 4" x 3" | 02962       | 20      | .60            | 1/4        |   |   |   |   |   |

**ADAPTER • BUSHING (DWV SPIGOT X S/D HUB)****ABS DWV**

(Adapts DWV HUB To S/D SPIGOT)

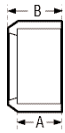
**A118**CONNECTION  
**DWV SP x S/D HUB**CHARLOTTE STYLE  
118NIBCO STYLE  
N/A

| Size | Part Number | Ctn Qty | Approx Net Wt. | Dimensions |       |   |   |   |   |
|------|-------------|---------|----------------|------------|-------|---|---|---|---|
|      |             |         |                | A          | B     | C | D | E | F |
| 3"   | 02990       | 25      | .09            | 1-1/2      | 1-3/4 |   |   |   |   |
| 4"   | 02991       | 10      | .15            | 1-3/4      | 2     |   |   |   |   |

**ADAPTER • NO HUB****ABS DWV**

(Adapts CI No Hub To DWV Pipe)

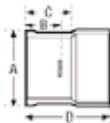
**A119**CONNECTION  
**CI NO H x DWV H**CHARLOTTE STYLE  
119NIBCO STYLE  
5805-N

| Size | Part Number | Ctn Qty | Approx Net Wt. | Dimensions |       |         |         |   |   |
|------|-------------|---------|----------------|------------|-------|---------|---------|---|---|
|      |             |         |                | A          | B     | C       | D       | E | F |
| 2"   | 02954       | 25      | .12            | 2-3/8      | 1-1/8 | 1-5/8   | 2-1/2   |   |   |
| 3"   | 02955       | 20      | .29            | 3-3/8      | 1-1/8 | 1-7/8   | 3-3/8   |   |   |
| 4"   | 02956       | 15      | .47            | 4-7/16     | 1-1/8 | 1-15/16 | 3-11/16 |   |   |

**ADAPTER • HUB • CAST IRON****ABS DWV**

(Adapts CI To DWV Pipe)

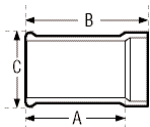
**A123**CONNECTION  
**CI SP x DWV H**CHARLOTTE STYLE  
123NIBCO STYLE  
5805

| Size | Part Number | Ctn Qty | Approx Net Wt. | Dimensions |       |       |   |   |   |
|------|-------------|---------|----------------|------------|-------|-------|---|---|---|
|      |             |         |                | A          | B     | C     | D | E | F |
| 2"   | 02957       | 20      | .23            | 3-1/2      | 4-3/4 | 2-3/4 |   |   |   |
| 3"   | 02958       | 10      | .54            | 4-1/4      | 5-7/8 | 3-3/4 |   |   |   |
| 4"   | 02959       | 20      | .86            | 4-7/8      | 6-5/8 | 4-3/4 |   |   |   |

**ADAPTER • HUB • CAST IRON • INCREASER**

**ABS DWV**

(ADAPTS CI HUB TO DWV PIPE) **A123R**

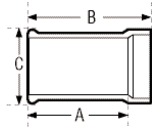

| Size        | Part Number | Ctn Qty | Approx Net Wt. | Dimensions |       |       |   |   |   |
|-------------|-------------|---------|----------------|------------|-------|-------|---|---|---|
|             |             |         |                | A          | B     | C     | D | E | F |
| 2" x 1-1/2" | 02961       | 20      | .21            | 3-3/8      | 4-1/8 | 2-5/8 |   |   |   |
| 3" x 1-1/2" | 02964       | 10      | .15            | 3-9/16     | 4-7/8 | 3-5/8 |   |   |   |
| 4" x 3"     | 02960       | 10      | .78            | 4          | 5-3/4 | 4-3/4 |   |   |   |

**COUPLING • REPAIR**

**ABS DWV**

**A130**



| Size   | Part Number | Ctn Qty | Approx Net Wt. | Dimensions |   |   |   |   |   |
|--------|-------------|---------|----------------|------------|---|---|---|---|---|
|        |             |         |                | A          | B | C | D | E | F |
| 1-1/2" | 02965       | 20      | .06            | 1-1/2      |   |   |   |   |   |
| 2"     | 02966       | 20      | .09            | 1-3/4      |   |   |   |   |   |
| 3"     | 02967       | 20      | .32            | 3          |   |   |   |   |   |
| 4"     | 02968       | 5       | .56            | 3-1/2      |   |   |   |   |   |

**CAP • TEST • STYRENE**

**ABS DWV**

**A131**

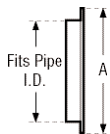

| Size   | Part Number | Ctn Qty | Approx Net Wt. | Dimensions |   |   |   |   |   |
|--------|-------------|---------|----------------|------------|---|---|---|---|---|
|        |             |         |                | A          | B | C | D | E | F |
| 1-1/2" | 02411       | 100     | .01            | 1-15/16    |   |   |   |   |   |
| 2"     | 02412       | 100     | .01            | 2-3/8      |   |   |   |   |   |
| 3"     | 02413       | 50      | .03            | 3-1/2      |   |   |   |   |   |
| 4"     | 02414       | 50      | .05            | 4-1/2      |   |   |   |   |   |

**NUT • SLIP JOINT • PLASTIC**

**ABS DWV**

**A140**



| Size   | Part Number | Ctn Qty | Approx Net Wt. | Dimensions |   |   |   |   |   |
|--------|-------------|---------|----------------|------------|---|---|---|---|---|
|        |             |         |                | A          | B | C | D | E | F |
| 1-1/4" | 02743       | 400     | .03            | 1 1/16     |   |   |   |   |   |
| 1-1/2" | 02744       | 100     | .03            | 1 1/16     |   |   |   |   |   |
| 2"     | 02741       | 100     | .38            | 1 1/16     |   |   |   |   |   |



TUBE & PIPE

METAL FITTINGS & NIPPLES

PLASTIC FITTINGS

VALVES

FILTER-DRYERS & STRAINERS

## WASHER • SLIP JOINT

ABS DWV

## A141

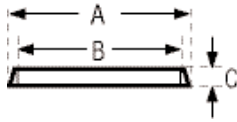

| CONNECTION<br><b>SJ</b> | CHARLOTTE STYLE |         |                | NIBCO STYLE |       |        | Dimensions |   |   |   |   |   |
|-------------------------|-----------------|---------|----------------|-------------|-------|--------|------------|---|---|---|---|---|
|                         | N/A             |         |                | N/A         |       |        | A          | B | C | D | E | F |
| Size                    | Part Number     | Ctn Qty | Approx Net Wt. |             |       |        |            |   |   |   |   |   |
| 1-1/2"                  | 02747           | 2000    | .003           | 1-47/64     | 1-1/2 | 1-3/64 |            |   |   |   |   |   |
| 1-1/2" x 1-1/4"         | 02748           | 500     | .01            | 1-23/32     | 1-1/4 | 1-7/64 |            |   |   |   |   |   |

(For use with 1-1/2 SJ Nut)

## NUT • ONE-PIECE POLY

ABS DWV

## A142

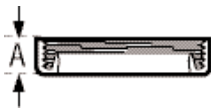

| CONNECTION<br><b>SJ x NPSM THREAD</b> | CHARLOTTE STYLE |         |                | NIBCO STYLE |  |  | Dimensions |   |   |   |   |   |
|---------------------------------------|-----------------|---------|----------------|-------------|--|--|------------|---|---|---|---|---|
|                                       | N/A             |         |                | N/A         |  |  | A          | B | C | D | E | F |
| Size                                  | Part Number     | Ctn Qty | Approx Net Wt. |             |  |  |            |   |   |   |   |   |
| 1-1/4"                                | 01036           | 150     | .023           | 5/8         |  |  |            |   |   |   |   |   |
| 1-1/2"                                | 01038           | 125     | .025           | 5/8         |  |  |            |   |   |   |   |   |

## ELBOW • 1/4 BEND

ABS DWV

## A300

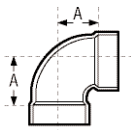

| CONNECTION<br><b>H x H</b> | CHARLOTTE STYLE |         |                | NIBCO STYLE |  |  | Dimensions |   |   |   |   |   |
|----------------------------|-----------------|---------|----------------|-------------|--|--|------------|---|---|---|---|---|
|                            | 300             |         |                | 5807        |  |  | A          | B | C | D | E | F |
| Size                       | Part Number     | Ctn Qty | Approx Net Wt. |             |  |  |            |   |   |   |   |   |
| 1-1/4"                     | 02875           | 50      | .11            | 1-9/16      |  |  |            |   |   |   |   |   |
| 1-1/2"                     | 02876           | 100     | .13            | 1-3/4       |  |  |            |   |   |   |   |   |
| 2"                         | 02877           | 50      | .22            | 2-5/16      |  |  |            |   |   |   |   |   |
| 3"                         | 02878           | 25      | .61            | 3-1/16      |  |  |            |   |   |   |   |   |
| 4"                         | 02879           | 10      | 1.12           | 3-7/8       |  |  |            |   |   |   |   |   |
| 6"                         | 03130           | 3       | 2.81           | 5           |  |  |            |   |   |   |   |   |

## ELBOW • 1/4 BEND • REDUCING

ABS DWV

## A300R

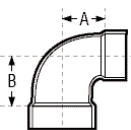

| CONNECTION<br><b>H x H</b> | CHARLOTTE STYLE |         |                | NIBCO STYLE |        |  | Dimensions |   |   |   |   |   |
|----------------------------|-----------------|---------|----------------|-------------|--------|--|------------|---|---|---|---|---|
|                            | 300-R           |         |                | N/A         |        |  | A          | B | C | D | E | F |
| Size                       | Part Number     | Ctn Qty | Approx Net Wt. |             |        |  |            |   |   |   |   |   |
| 2" x 1-1/2"                | 03092           | 10      | .24            | 2-5/16      | 2-7/16 |  |            |   |   |   |   |   |

**ELBOW • SIDE INLET • 1/4 BEND**

**ABS DWV**

**A300S**

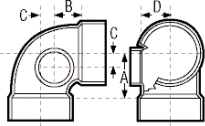

| CONNECTION<br><b>ALL HUB</b> | CHARLOTTE STYLE |         | NIBCO STYLE    |        | Dimensions |   |       |   |   |  |
|------------------------------|-----------------|---------|----------------|--------|------------|---|-------|---|---|--|
|                              | Part Number     | Ctn Qty | Approx Net Wt. | A      | B          | C | D     | E | F |  |
|                              | 300-S           |         |                |        |            |   |       |   |   |  |
| 3" x 3" x 1-1/2"             | 03069           | 10      | .79            | 3-1/16 | 2-1/16     | 1 | 1-7/8 |   |   |  |
| 3" x 3" x 2"                 | 03070           | 10      | .79            | 3-1/16 | 2-1/16     | 1 | 1-7/8 |   |   |  |

**ELBOW • STREET • 1/4 BEND**

**ABS DWV**

**A302**

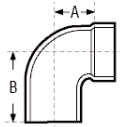

| CONNECTION<br><b>SP x H</b> | CHARLOTTE STYLE |         | NIBCO STYLE    |        | Dimensions |   |   |   |   |  |
|-----------------------------|-----------------|---------|----------------|--------|------------|---|---|---|---|--|
|                             | Part Number     | Ctn Qty | Approx Net Wt. | A      | B          | C | D | E | F |  |
|                             | 302             |         |                |        |            |   |   |   |   |  |
| 1-1/4"                      | 02894           | 50      | .12            | 1-9/16 | 2-1/4      |   |   |   |   |  |
| 1-1/2"                      | 02880           | 100     | .15            | 1-3/4  | 2-7/16     |   |   |   |   |  |
| 2"                          | 02881           | 50      | .25            | 2-5/16 | 3-1/16     |   |   |   |   |  |
| 3"                          | 02882           | 20      | .71            | 3-1/16 | 4-9/16     |   |   |   |   |  |
| 4"                          | 02883           | 10      | 1.29           | 3-7/8  | 5-5/8      |   |   |   |   |  |
| 6"                          | 02889           | 5       | 3.32           | 5      | 8          |   |   |   |   |  |

**ELBOW • STREET • 1/4 BEND • W/LOW HEEL INLET**

**ABS DWV**

**A303**

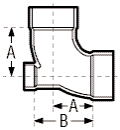

| CONNECTION<br><b>ALL HUB</b> | CHARLOTTE STYLE |         | NIBCO STYLE    |        | Dimensions |   |   |   |   |  |
|------------------------------|-----------------|---------|----------------|--------|------------|---|---|---|---|--|
|                              | Part Number     | Ctn Qty | Approx Net Wt. | A      | B          | C | D | E | F |  |
|                              | 303             |         |                |        |            |   |   |   |   |  |
| 3" x 3" x 1-1/2"             | 03041           | 25      | .81            | 3-1/16 | 4-1/2      |   |   |   |   |  |
| 3" x 3" x 2"                 | 03042           | 25      | .82            | 3-1/16 | 4-7/16     |   |   |   |   |  |
| 4" x 4" x 2"                 | 03043           | 15      | 1.48           | 3-7/8  | 5-7/16     |   |   |   |   |  |

TUBE & PIPE

METAL FITTINGS & NIPPLES

PLASTIC FITTINGS

VALVES

FILTER-DRYERS & STRAINERS



## ELBOW • LONG SWEEP • 1/4 BEND

ABS DWV

## A304



| CONNECTION<br>H x H | CHARLOTTE STYLE<br>304 |            | NIBCO STYLE<br>5807-LT |         | Dimensions |   |   |   |   |  |
|---------------------|------------------------|------------|------------------------|---------|------------|---|---|---|---|--|
|                     | Part<br>Number         | Ctn<br>Qty | Approx<br>Net Wt.      | A       | B          | C | D | E | F |  |
| 1-1/4"              | 02870                  | 50         | .17                    | 2-1/4   |            |   |   |   |   |  |
| 1-1/2"              | 02871                  | 50         | .21                    | 2-3/4   |            |   |   |   |   |  |
| 2"                  | 02872                  | 25         | .33                    | 3-1/4   |            |   |   |   |   |  |
| 3"                  | 02873                  | 10         | .93                    | 4-1/16  |            |   |   |   |   |  |
| 4"                  | 02874                  | 5          | 1.60                   | 4-15/16 |            |   |   |   |   |  |

## ELBOW • LONG SWEEP • 1/4 BEND • W/HIGH INLET

ABS DWV

## A305

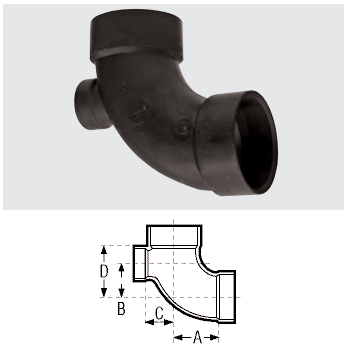

| CONNECTION<br>ALL HUB | CHARLOTTE STYLE<br>N/A |            | NIBCO STYLE<br>5861 |        | Dimensions |        |        |   |   |  |
|-----------------------|------------------------|------------|---------------------|--------|------------|--------|--------|---|---|--|
|                       | Part<br>Number         | Ctn<br>Qty | Approx<br>Net Wt.   | A      | B          | C      | D      | E | F |  |
| 3" x 3" x 1-1/2"      | 03028                  | 10         | .95                 | 4-1/16 | 2-1/4      | 1-9/16 | 3-5/8  |   |   |  |
| 3" x 3" x 2"          | 03027                  | 25         | .96                 | 4-1/16 | 2-1/4      | 1-9/16 | 4-1/16 |   |   |  |

## ELBOW • LONG SWEEP • 1/4 BEND • W/LOW INLET

ABS DWV

## A307



| CONNECTION<br>ALL HUB | CHARLOTTE STYLE<br>N/A |            | NIBCO STYLE<br>N/A |        | Dimensions |   |   |   |   |  |
|-----------------------|------------------------|------------|--------------------|--------|------------|---|---|---|---|--|
|                       | Part<br>Number         | Ctn<br>Qty | Approx<br>Net Wt.  | A      | B          | C | D | E | F |  |
| 3" x 3" x 1-1/2"      | 03025                  | 10         | .94                | 4-1/16 | 4-3/4      |   |   |   |   |  |
| 3" x 3" x 2"          | 03024                  | 25         | .97                | 4-1/16 | 4-15/16    |   |   |   |   |  |

## ELBOW • LONG SWEEP • 1/4 BEND • STREET

ABS DWV

## A309

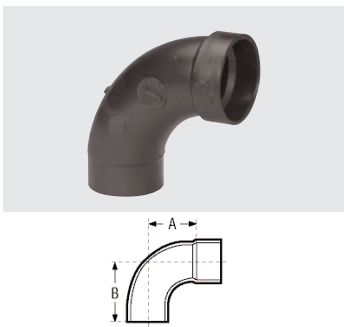

| CONNECTION<br>SP x H | CHARLOTTE STYLE<br>309 |            | NIBCO STYLE<br>5807-2-LT |        | Dimensions |   |   |   |   |  |
|----------------------|------------------------|------------|--------------------------|--------|------------|---|---|---|---|--|
|                      | Part<br>Number         | Ctn<br>Qty | Approx<br>Net Wt.        | A      | B          | C | D | E | F |  |
| 1-1/2"               | 03060                  | 50         | .21                      | 2-1/4  | 2-15/16    |   |   |   |   |  |
| 2"                   | 03061                  | 25         | .29                      | 3-1/4  | 4          |   |   |   |   |  |
| 3"                   | 03063                  | 20         | .89                      | 4-1/16 | 5-9/16     |   |   |   |   |  |

**ELBOW • 1/4 BEND • W/LOW INLET • STREET**

**ABS DWV**

**A310**



CONNECTION  
**H x SP x H**

CHARLOTTE STYLE  
310

NIBCO STYLE  
5861-LH

| Size         | Part Number | Ctn Qty | Approx Net Wt. | Dimensions |         |       |   |   |   |  |
|--------------|-------------|---------|----------------|------------|---------|-------|---|---|---|--|
|              |             |         |                | A          | B       | C     | D | E | F |  |
| 3" x 3" x 2" | 03026       | 15      | .82            | 3-1/8      | 5-15/16 | 4-5/8 |   |   |   |  |



**ELBOW • LONG SWEEP • 1/4 BEND • W/SIDE INLET**

**ABS DWV**

**A311**



CONNECTION  
**ALL HUB**

CHARLOTTE STYLE  
N/A

NIBCO STYLE  
N/A

| Size             | Part Number | Ctn Qty | Approx Net Wt. | Dimensions |   |        |        |   |   |  |
|------------------|-------------|---------|----------------|------------|---|--------|--------|---|---|--|
|                  |             |         |                | A          | B | C      | D      | E | F |  |
| 3" x 3" x 1-1/2" | 03051       | 10      | .87            | 4-1/16     | 3 | 1-1/16 | 2-3/16 |   |   |  |
| 3" x 3" x 2"     | 03050       | 25      | .93            | 4-1/16     | 3 | 1-1/16 | 2-3/16 |   |   |  |

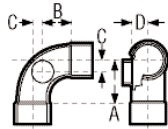

**ELBOW • 1/6 BEND**

**ABS DWV**

**A319**



CONNECTION  
**H x H**

CHARLOTTE STYLE  
319

NIBCO STYLE  
5860

| Size   | Part Number | Ctn Qty | Approx Net Wt. | Dimensions |   |   |   |   |   |  |
|--------|-------------|---------|----------------|------------|---|---|---|---|---|--|
|        |             |         |                | A          | B | C | D | E | F |  |
| 1-1/2" | 02895       | 50      | .11            | 1/2        |   |   |   |   |   |  |
| 2"     | 02896       | 40      | .16            | 1-1/16     |   |   |   |   |   |  |
| 3"     | 02897       | 20      | .47            | 1-3/16     |   |   |   |   |   |  |
| 4"     | 02982       | 15      | .84            | 1-5/16     |   |   |   |   |   |  |
| 6"     | 02988       | 3       | 3.87           | 1-7/16     |   |   |   |   |   |  |

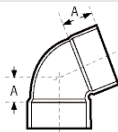

**ELBOW • 1/6 BEND • STREET**

**ABS DWV**

**A320**



CONNECTION  
**SP x H**

CHARLOTTE STYLE  
320

NIBCO STYLE  
5860-2

| Size   | Part Number | Ctn Qty | Approx Net Wt. | Dimensions |        |   |   |   |   |  |
|--------|-------------|---------|----------------|------------|--------|---|---|---|---|--|
|        |             |         |                | A          | B      | C | D | E | F |  |
| 1-1/2" | 03020       | 40      | .12            | 1          | 1 1/16 |   |   |   |   |  |
| 2"     | 03021       | 25      | .19            | 1-7/16     | 2-1/16 |   |   |   |   |  |
| 3"     | 03022       | 20      | .57            | 1-11/16    | 3-3/16 |   |   |   |   |  |
| 4"     | 03023       | 5       | 1.10           | 2-1/16     | 3-9/16 |   |   |   |   |  |

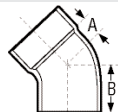

**ELBOW • 1/8 BEND****ABS DWV****A321**

| CONNECTION<br><b>H x H</b> | CHARLOTTE STYLE<br>321 |            |                   | NIBCO STYLE<br>5806 |   | Dimensions |   |   |   |  |  |
|----------------------------|------------------------|------------|-------------------|---------------------|---|------------|---|---|---|--|--|
|                            | Part<br>Number         | Ctn<br>Qty | Approx<br>Net Wt. | A                   | B | C          | D | E | F |  |  |
| Size                       |                        |            |                   |                     |   |            |   |   |   |  |  |
| 1-1/4"                     | 02884                  | 50         | .14               | 1                   |   |            |   |   |   |  |  |
| 1-1/2"                     | 02885                  | 100        | .18               | 1-1/8               |   |            |   |   |   |  |  |
| 2"                         | 02886                  | 50         | .30               | 1-1/2               |   |            |   |   |   |  |  |
| 3"                         | 02887                  | 20         | .82               | 1-3/4               |   |            |   |   |   |  |  |
| 4"                         | 02888                  | 10         | 1.50              | 2-3/16              |   |            |   |   |   |  |  |
| 6"                         | 02132                  | 3          | 4.11              | 2                   |   |            |   |   |   |  |  |

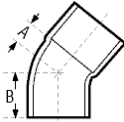
**ELBOW • 1/8 BEND • STREET****ABS DWV****A323**

| CONNECTION<br><b>SP x H</b> | CHARLOTTE STYLE<br>323 |            |                   | NIBCO STYLE<br>5806-2 |         | Dimensions |   |   |   |  |  |
|-----------------------------|------------------------|------------|-------------------|-----------------------|---------|------------|---|---|---|--|--|
|                             | Part<br>Number         | Ctn<br>Qty | Approx<br>Net Wt. | A                     | B       | C          | D | E | F |  |  |
| Size                        |                        |            |                   |                       |         |            |   |   |   |  |  |
| 1-1/4"                      | 03016                  | 50         | .10               | 1                     | 1-11/16 |            |   |   |   |  |  |
| 1-1/2"                      | 02890                  | 100        | .13               | 1-1/8                 | 1-13/16 |            |   |   |   |  |  |
| 2"                          | 02891                  | 50         | .20               | 1-1/2                 | 2-1/4   |            |   |   |   |  |  |
| 3"                          | 02892                  | 20         | .57               | 1-3/4                 | 3-1/4   |            |   |   |   |  |  |
| 4"                          | 02893                  | 10         | 1.02              | 2-3/16                | 3-15/16 |            |   |   |   |  |  |
| 6"                          | 03133                  | 3          | 2.72              | 2                     | 5       |            |   |   |   |  |  |

**ELBOW • 1/16 BEND****ABS DWV****A324**

| CONNECTION<br><b>H x H</b> | CHARLOTTE STYLE<br>324 |            |                   | NIBCO STYLE<br>5808 |   | Dimensions |   |   |   |  |  |
|----------------------------|------------------------|------------|-------------------|---------------------|---|------------|---|---|---|--|--|
|                            | Part<br>Number         | Ctn<br>Qty | Approx<br>Net Wt. | A                   | B | C          | D | E | F |  |  |
| Size                       |                        |            |                   |                     |   |            |   |   |   |  |  |
| 1-1/2"                     | 02899                  | 50         | .11               | 1/2                 |   |            |   |   |   |  |  |
| 2"                         | 02900                  | 25         | .16               | 1-1/16              |   |            |   |   |   |  |  |
| 3"                         | 02901                  | 20         | .47               | 1-3/16              |   |            |   |   |   |  |  |
| 4"                         | 02983                  | 15         | .84               | 1-5/16              |   |            |   |   |   |  |  |
| 6"                         | 02988                  | 3          | 3.87              | 1-7/16              |   |            |   |   |   |  |  |

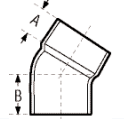
**ELBOW • 1/16 BEND • STREET****ABS DWV****A326**

| CONNECTION<br><b>SP x H</b> | CHARLOTTE STYLE<br>326 |            |                   | NIBCO STYLE<br>5808-2 |        | Dimensions |   |   |   |  |  |
|-----------------------------|------------------------|------------|-------------------|-----------------------|--------|------------|---|---|---|--|--|
|                             | Part<br>Number         | Ctn<br>Qty | Approx<br>Net Wt. | A                     | B      | C          | D | E | F |  |  |
| Size                        |                        |            |                   |                       |        |            |   |   |   |  |  |
| 1-1/2"                      | 02984                  | 50         | .09               | 1/2                   | 1-3/16 |            |   |   |   |  |  |
| 2"                          | 02985                  | 25         | .15               | 1-1/16                | 1-7/16 |            |   |   |   |  |  |
| 3"                          | 02986                  | 20         | .44               | 13/16                 | 2-5/16 |            |   |   |   |  |  |
| 4"                          | 02987                  | 10         | .78               | 1                     | 2-3/4  |            |   |   |   |  |  |

**ELBOW • DOUBLE • 1/4 BEND**

**ABS DWV**

**A327**

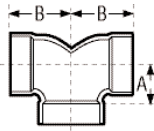

| CONNECTION<br><b>ALL HUB</b> | CHARLOTTE STYLE |         |                | NIBCO STYLE |        |   | Dimensions |   |   |  |  |  |  |
|------------------------------|-----------------|---------|----------------|-------------|--------|---|------------|---|---|--|--|--|--|
|                              | Part Number     | Ctn Qty | Approx Net Wt. | A           | B      | C | D          | E | F |  |  |  |  |
|                              | 327             |         |                |             |        |   |            |   |   |  |  |  |  |
| Size                         |                 |         |                |             |        |   |            |   |   |  |  |  |  |
| 1-1/2"                       | 03045           | 20      | .19            | 1-3/4       | 1-3/4  |   |            |   |   |  |  |  |  |
| 2"                           | 03046           | 25      | .33            | 2-5/16      | 2-5/16 |   |            |   |   |  |  |  |  |
| 3"                           | 03047           | 10      | 1.11           | 3-1/16      | 3-1/16 |   |            |   |   |  |  |  |  |
| <b>REDUCING</b>              |                 |         |                |             |        |   |            |   |   |  |  |  |  |
| 2" x 1-1/2" x 1-1/2"         | 03049           | 25      | .23            | 1-15/16     | 1-3/4  |   |            |   |   |  |  |  |  |

**ELBOW • CLOSET BEND • REDUCING • SHORT RADIUS**

**ABS DWV**

**A328**

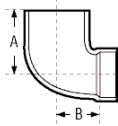

| CONNECTION<br><b>SP x H</b> | CHARLOTTE STYLE |         |                | NIBCO STYLE |       |   | Dimensions |   |   |  |  |  |  |
|-----------------------------|-----------------|---------|----------------|-------------|-------|---|------------|---|---|--|--|--|--|
|                             | N/A             |         |                |             |       |   |            |   |   |  |  |  |  |
| Size                        | Part Number     | Ctn Qty | Approx Net Wt. | A           | B     | C | D          | E | F |  |  |  |  |
| 4" x 3"                     | 03105           | 10      | 1.02           | 5           | 3-3/8 |   |            |   |   |  |  |  |  |

**ELBOW • CLOSET BEND • REDUCING • SHORT RADIUS • W/TEST CAP**

**ABS DWV**

**A328X**



| CONNECTION<br><b>SP x H</b> | CHARLOTTE STYLE |         |                | NIBCO STYLE |       |   | Dimensions |   |   |  |  |  |  |
|-----------------------------|-----------------|---------|----------------|-------------|-------|---|------------|---|---|--|--|--|--|
|                             | N/A             |         |                |             |       |   |            |   |   |  |  |  |  |
| Size                        | Part Number     | Ctn Qty | Approx Net Wt. | A           | B     | C | D          | E | F |  |  |  |  |
| 4" x 3"                     | 03104           | 10      | 1.06           | 5-1/16      | 3-3/8 |   |            |   |   |  |  |  |  |

**ELBOW • CLOSET BEND • REDUCING**

**ABS DWV**

**A329**

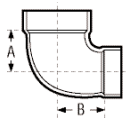

| CONNECTION<br><b>SP x H</b> | CHARLOTTE STYLE |         |                | NIBCO STYLE |       |   | Dimensions |   |   |  |  |  |  |
|-----------------------------|-----------------|---------|----------------|-------------|-------|---|------------|---|---|--|--|--|--|
|                             | 329             |         |                |             |       |   |            |   |   |  |  |  |  |
| Size                        | Part Number     | Ctn Qty | Approx Net Wt. | A           | B     | C | D          | E | F |  |  |  |  |
| 4" x 3"                     | 03093           | 10      | .95            | 3           | 3-3/8 |   |            |   |   |  |  |  |  |



## ELBOW • CLOSET BEND • REDUCING • STREET ELBOW

ABS DWV

## A330

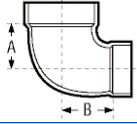

| CONNECTION<br>SP x H | CHARLOTTE STYLE<br>330 |            | NIBCO STYLE<br>5807-2-CL |   | Dimensions |   |   |   |   |  |
|----------------------|------------------------|------------|--------------------------|---|------------|---|---|---|---|--|
| Size                 | Part<br>Number         | Ctn<br>Qty | Approx<br>Net Wt.        | A | B          | C | D | E | F |  |
| 4" x 3"              | 03107                  | 10         | 1.13                     | 6 | 3-3/8      |   |   |   |   |  |

## ELBOW • CLOSET BEND • REDUCING • STREET • TEST CAP

ABS DWV

## A330X

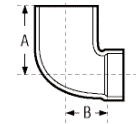

| CONNECTION<br>SP x H | CHARLOTTE STYLE<br>330X |            | NIBCO STYLE<br>N/A |        | Dimensions |   |   |   |   |  |
|----------------------|-------------------------|------------|--------------------|--------|------------|---|---|---|---|--|
| Size                 | Part<br>Number          | Ctn<br>Qty | Approx<br>Net Wt.  | A      | B          | C | D | E | F |  |
| 4" x 3"              | 03108                   | 10         | 1.16               | 6-1/16 | 3-3/8      |   |   |   |   |  |

## ELBOW • VENT ELL

ABS DWV

## A331

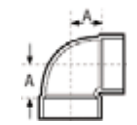

| CONNECTION<br>H x H | CHARLOTTE STYLE<br>331 |            | NIBCO STYLE<br>5807-V |        | Dimensions |   |   |   |   |  |
|---------------------|------------------------|------------|-----------------------|--------|------------|---|---|---|---|--|
| Size                | Part<br>Number         | Ctn<br>Qty | Approx<br>Net Wt.     | A      | B          | C | D | E | F |  |
| 1-1/4"              | 03083                  | 20         | .11                   | 1      |            |   |   |   |   |  |
| 1-1/2"              | 03084                  | 20         | .15                   | 1-3/16 |            |   |   |   |   |  |
| 2"                  | 03085                  | 30         | .21                   | 1-1/2  |            |   |   |   |   |  |
| 3"                  | 03086                  | 25         | .66                   | 1-7/8  |            |   |   |   |   |  |
| 4"                  | 03087                  | 10         | 1.05                  | 2-1/2  |            |   |   |   |   |  |

## ELBOW • VENT ELL

ABS DWV

## A332

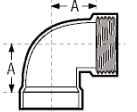

| CONNECTION<br>H x FPT | CHARLOTTE STYLE<br>N/A |            | NIBCO STYLE<br>5807-3 |       | Dimensions |   |   |   |   |  |
|-----------------------|------------------------|------------|-----------------------|-------|------------|---|---|---|---|--|
| Size                  | Part<br>Number         | Ctn<br>Qty | Approx<br>Net Wt.     | A     | B          | C | D | E | F |  |
| 3"                    | 03071                  | 20         | .65                   | 1-7/8 |            |   |   |   |   |  |

**ELBOW • VENT ELL • STREET**

**ABS DWV**

**A333**

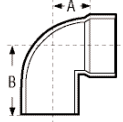
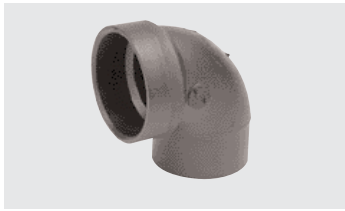

| CONNECTION<br><b>SP x H</b> | CHARLOTTE STYLE<br>333 |         |                | NIBCO STYLE<br>5807-2-V |       |   |   |   |   |
|-----------------------------|------------------------|---------|----------------|-------------------------|-------|---|---|---|---|
|                             | Part Number            | Ctn Qty | Approx Net Wt. | Dimensions              |       |   |   |   |   |
| Size                        |                        |         |                | A                       | B     | C | D | E | F |
| 1-1/2"                      | 03088                  | 25      | .13            | 1-3/16                  | 1-7/8 |   |   |   |   |
| 2"                          | 03089                  | 20      | .20            | 1-1/2                   | 2-1/4 |   |   |   |   |
| 3"                          | 03090                  | 10      | .58            | 1-9/16                  | 2-5/8 |   |   |   |   |

**TEE • SANITARY**

**ABS DWV**

**A400**

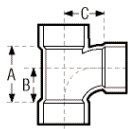

| CONNECTION<br><b>ALL HUB</b> | CHARLOTTE STYLE<br>400 |         |                | NIBCO STYLE<br>5811 |        |        |   |   |   |
|------------------------------|------------------------|---------|----------------|---------------------|--------|--------|---|---|---|
|                              | Part Number            | Ctn Qty | Approx Net Wt. | Dimensions          |        |        |   |   |   |
| Size                         |                        |         |                | A                   | B      | C      | D | E | F |
| 1-1/4"                       | 02751                  | 50      | .17            | 2-5/16              | 1-9/16 | 1-9/16 |   |   |   |
| 1-1/2"                       | 02752                  | 100     | .23            | 2-3/4               | 1-3/4  | 1-3/4  |   |   |   |
| 2"                           | 02753                  | 35      | .36            | 3-11/16             | 2-5/16 | 2-5/16 |   |   |   |
| 3"                           | 02754                  | 30      | 1.04           | 4-7/8               | 3-1/16 | 3-1/16 |   |   |   |
| 4"                           | 02755                  | 5       | 1.81           | 6-1/8               | 3-7/8  | 3-7/8  |   |   |   |
| 6"                           | 02756                  | 5       | 4.67           | 8-1/2               | 5      | 5      |   |   |   |

**TEE • SANITARY • REDUCING**

**ABS DWV**

**A401**

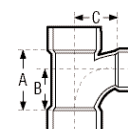

| CONNECTION<br><b>ALL HUB</b> | CHARLOTTE STYLE<br>401 |         |                | NIBCO STYLE<br>5811 |         |         |   |   |   |
|------------------------------|------------------------|---------|----------------|---------------------|---------|---------|---|---|---|
|                              | Part Number            | Ctn Qty | Approx Net Wt. | Dimensions          |         |         |   |   |   |
| Size                         |                        |         |                | A                   | B       | C       | D | E | F |
| 1-1/2" x 1-1/4" x 1-1/4"     | 02759                  | 20      | .19            | 2-1/2               | 1-1/2   | 1-11/16 |   |   |   |
| 1-1/2" x 1-1/4" x 1-1/2"     | 02762                  | 20      | .23            | 2-3/4               | 1-3/4   | 1-3/4   |   |   |   |
| 1-1/2" x 1-1/2" x 1-1/4"     | 02757                  | 20      | .20            | 2-1/2               | 1-11/16 | 1-13/16 |   |   |   |
| 2" x 1-1/2" x 1-1/2"         | 02761                  | 25      | .29            | 3-1/8               | 1-15/16 | 2-3/16  |   |   |   |
| 2" x 1-1/2" x 2"             | 02760                  | 25      | .34            | 3-11/16             | 2-5/16  | 2-5/16  |   |   |   |
| 2" x 2" x 1-1/2"             | 02758                  | 50      | .30            | 3-1/8               | 1-15/16 | 2-3/16  |   |   |   |
| 3" x 3" x 1-1/2"             | 02764                  | 20      | .62            | 2-11/16             | 1-3/4   | 2-9/16  |   |   |   |
| 3" x 3" x 2"                 | 02763                  | 10      | .71            | 3-5/16              | 2-1/8   | 2-7/8   |   |   |   |
| 4" x 4" x 2"                 | 02765                  | 10      | 1.03           | 3-3/16              | 2-1/16  | 3-5/16  |   |   |   |
| 4" x 4" x 3"                 | 02766                  | 10      | 1.42           | 4-3/4               | 3       | 3-9/16  |   |   |   |
| 6" x 6" x 4"                 | 02768                  | 6       | 3.06           | 5-7/8               | 6-5/8   | 4-1/2   |   |   |   |



## TEE • SANITARY • STREET

ABS DWV

## A403

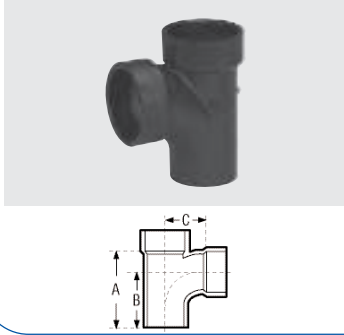

| CONNECTION<br>SP x H x H | CHARLOTTE STYLE<br>403 |            | NIBCO STYLE<br>5811-2 |        | Dimensions |        |   |   |   |  |
|--------------------------|------------------------|------------|-----------------------|--------|------------|--------|---|---|---|--|
|                          | Part<br>Number         | Ctn<br>Qty | Approx<br>Net Wt.     | A      | B          | C      | D | E | F |  |
| 1-1/2"                   | 03112                  | 20         | .21                   | 3-7/16 | 2-7/16     | 1-3/4  |   |   |   |  |
| 2"                       | 03113                  | 25         | .29                   | 4-7/16 | 3-1/16     | 2-5/16 |   |   |   |  |
| 3"                       | 03114                  | 30         | .99                   | 6-3/8  | 4-9/16     | 3-1/16 |   |   |   |  |
| 4"                       | 03120                  | 10         | 1.76                  | 7-7/8  | 5-5/8      | 3-7/8  |   |   |   |  |

## TEE • SANITARY • STREET • REDUCING

ABS DWV

## A404



| CONNECTION<br>SP x H x H | CHARLOTTE STYLE<br>404 |            | NIBCO STYLE<br>5811-2 |         | Dimensions |        |   |   |   |  |
|--------------------------|------------------------|------------|-----------------------|---------|------------|--------|---|---|---|--|
|                          | Part<br>Number         | Ctn<br>Qty | Approx<br>Net Wt.     | A       | B          | C      | D | E | F |  |
| 2" x 1-1/2" x 1-1/2"     | 03115                  | 25         | .28                   | 3-7/8   | 2-11/16    | 2-3/16 |   |   |   |  |
| 2" x 1-1/2" x 2"         | 03116                  | 25         | .34                   | 4-7/16  | 3-1/16     | 2-5/16 |   |   |   |  |
| 2" x 2" x 1-1/2"         | 03117                  | 25         | .29                   | 3-7/8   | 2-11/16    | 2-3/16 |   |   |   |  |
| 3" x 3" x 1-1/2"         | 03118                  | 10         | .58                   | 4-3/16  | 3-1/4      | 2-9/16 |   |   |   |  |
| 3" x 3" x 2"             | 03119                  | 10         | .67                   | 4-13/16 | 3-5/8      | 2-7/8  |   |   |   |  |

## TEE • SANITARY • W/LEFT SIDE INLET

ABS DWV

## A416

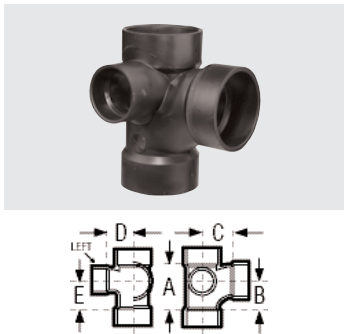

| CONNECTION<br>ALL HUB | CHARLOTTE STYLE<br>416 |            | NIBCO STYLE<br>5871 |        | Dimensions |        |        |         |  |  |
|-----------------------|------------------------|------------|---------------------|--------|------------|--------|--------|---------|--|--|
|                       | Part<br>Number         | Ctn<br>Qty | Approx<br>Net Wt.   | A      | B          | C      | D      | E       |  |  |
| 3" x 3" x 2" x 2"     | 02780                  | 10         | .92                 | 3-5/16 | 2-1/8      | 2-7/8  | 2-7/8  | 2-1/8   |  |  |
| 3" x 3" x 3" x 1-1/2" | 02781                  | 10         | 1.08                | 4-7/8  | 3-1/16     | 3-1/16 | 2-9/16 | 3-11/16 |  |  |
| 3" x 3" x 3" x 2"     | 02782                  | 10         | 1.13                | 4-7/8  | 3-1/16     | 3-1/16 | 2-7/8  | 3-11/16 |  |  |

## TEE • SANITARY • W/RIGHT SIDE INLET

ABS DWV

## A417



| CONNECTION<br>ALL HUB | CHARLOTTE STYLE<br>417 |            | NIBCO STYLE<br>5872 |       | Dimensions |        |        |         |  |  |
|-----------------------|------------------------|------------|---------------------|-------|------------|--------|--------|---------|--|--|
|                       | Part<br>Number         | Ctn<br>Qty | Approx<br>Net Wt.   | A     | B          | C      | D      | E       |  |  |
| 3" x 3" x 3" x 1-1/2" | 02795                  | 10         | 1.12                | 4-7/8 | 3-1/16     | 3-1/16 | 2-9/16 | 3-11/16 |  |  |
| 3" x 3" x 3" x 2"     | 02796                  | 10         | 1.17                | 4-7/8 | 3-1/16     | 3-1/16 | 2-7/8  | 3-11/16 |  |  |

**TEE • SANITARY • W/RIGHT & LEFT INLET**

**ABS DWV**

**A418**

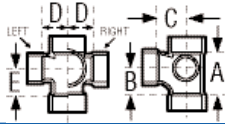

| Size                           | Part Number | Ctn Qty | Approx Net Wt. | Dimensions |        |        |        |         |
|--------------------------------|-------------|---------|----------------|------------|--------|--------|--------|---------|
|                                |             |         |                | A          | B      | C      | D      | E       |
| 3" x 3" x 3" x 1-1/2" x 1-1/2" | 02810       | 10      | .39            | 4-7/8      | 3-1/16 | 3-1/16 | 2-9/16 | 3-11/16 |
| 3" x 3" x 3" x 2" x 2"         | 02811       | 5       | 1.30           | 4-7/8      | 3-1/16 | 3-1/16 | 2-7/8  | 3-11/16 |

CONNECTION  
**ALL HUB**

CHARLOTTE STYLE  
N/A

NIBCO STYLE  
5870

TUBE & PIPE

METAL FITTINGS & NIPPLES

PLASTIC FITTINGS

VALVES

FILTER-DRYERS & STRAINERS

**TEE • DOUBLE • SANITARY**

**ABS DWV**

**A428**

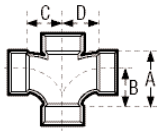

| Size   | Part Number | Ctn Qty | Approx Net Wt. | Dimensions |        |        |        |
|--------|-------------|---------|----------------|------------|--------|--------|--------|
|        |             |         |                | A          | B      | C      | D      |
| 1-1/2" | 02812       | 25      | .28            | 2-3/4      | 1-3/4  | 1-3/4  | 1-3/4  |
| 2"     | 02813       | 20      | .44            | 3-11/16    | 2-5/16 | 2-5/16 | 2-5/16 |
| 3"     | 02814       | 20      | 1.27           | 4-7/8      | 3-1/16 | 3-1/16 | 3-1/16 |
| 4"     | 02815       | 4       | 2.23           | 6-1/8      | 3-7/8  | 3-7/8  | 3-7/8  |

CONNECTION  
**ALL HUB**

CHARLOTTE STYLE  
428

NIBCO STYLE  
5835

**TEE • DOUBLE • SANITARY • REDUCING**

**ABS DWV**

**A429**

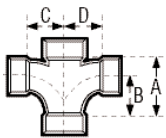

| Size                      | Part Number | Ctn Qty | Approx Net Wt. | Dimensions |         |        |        |   |
|---------------------------|-------------|---------|----------------|------------|---------|--------|--------|---|
|                           |             |         |                | A          | B       | C      | D      | E |
| 2" x 2" x 1-1/2" x 1-1/2" | 02817       | 20      | .36            | 31/8       | 1-15/16 | 2-3/16 | 2-3/16 |   |
| 3" x 3" x 1-1/2" x 1-1/2" | 02818       | 20      | .64            | 2-11/16    | 1-3/4   | 2-9/16 | 2-9/16 |   |
| 3" x 3" x 2" x 1-1/2"     | 02819       | 10      | .75            | 3          | 2-1/16  | 2-1/2  | 2-7/16 |   |
| 3" x 3" x 2" x 2"         | 02820       | 10      | .74            | 3-5/16     | 2-1/8   | 2-7/8  | 2-7/8  |   |
| 4" x 4" x 2" x 2"         | 02840       | 5       | 1.11           | 3-3/16     | 2-1/16  | 3-5/16 | 3-5/16 |   |
| 4" x 4" x 3" x 3"         | 02821       | 5       | 1.61           | 4-3/4      | 3       | 3-9/16 | 3-9/16 |   |

CONNECTION  
**ALL HUB**

CHARLOTTE STYLE  
429

NIBCO STYLE  
5835

**TEE • DOUBLE • SANITARY • STREET • REDUCING**

**ABS DWV**

**A431**

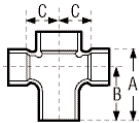

| Size              | Part Number | Ctn Qty | Approx Net Wt. | Dimensions |       |       |
|-------------------|-------------|---------|----------------|------------|-------|-------|
|                   |             |         |                | A          | B     | C     |
| 3" x 3" x 2" x 2" | 03310       | 10      | .80            | 4-13/16    | 3-5/8 | 2-7/8 |

CONNECTION  
**SP x H x H x H**

CHARLOTTE STYLE  
N/A

NIBCO STYLE  
N/A



## TEE • DOUBLE • SANITARY • W/SIDE INLET

ABS DWV

A438

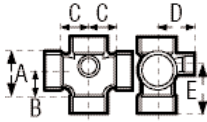

| CONNECTION<br><b>ALL HUB</b> | CHARLOTTE STYLE<br>N/A | NIBCO STYLE<br>5835-9 | Dimensions        |       |        |        |       |        |  |
|------------------------------|------------------------|-----------------------|-------------------|-------|--------|--------|-------|--------|--|
| Size                         | Part<br>Number         | Ctn<br>Qty            | Approx<br>Net Wt. | A     | B      | C      | D     | E      |  |
| 3" x 3" x 3" x 3" x 2"       | 02772                  | 10                    | 1.42              | 4-7/8 | 3-1/16 | 3-1/16 | 2-7/8 | 3-1/16 |  |

## TEE • DOUBLE • SANITARY • W/RIGHT &amp; LEFT SIDE INLET

ABS DWV

A439

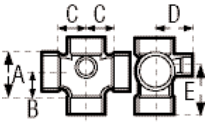

| CONNECTION<br><b>ALL HUB</b> | CHARLOTTE STYLE<br>N/A | NIBCO STYLE<br>5835-9-9 | Dimensions        |       |        |        |       |         |  |
|------------------------------|------------------------|-------------------------|-------------------|-------|--------|--------|-------|---------|--|
| Size                         | Part<br>Number         | Ctn<br>Qty              | Approx<br>Net Wt. | A     | B      | C      | D     | E       |  |
| 3" x 3" x 3" x 3" x 2" x 2"  | 02770                  | 10                      | 1.55              | 4-7/8 | 3-1/16 | 3-1/16 | 2-7/8 | 3-11/16 |  |

(W/ RIGHT OR LEFT SIDE INLET)

## TEE • VENT

ABS DWV

A441

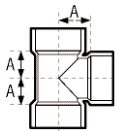

| CONNECTION<br><b>ALL HUB</b> | CHARLOTTE STYLE<br>441 | NIBCO STYLE<br>5811-V | Dimensions        |        |   |   |   |   |   |
|------------------------------|------------------------|-----------------------|-------------------|--------|---|---|---|---|---|
| Size                         | Part<br>Number         | Ctn<br>Qty            | Approx<br>Net Wt. | A      | B | C | D | E | F |
| 1-1/2"                       | 03403                  | 25                    | .20               | 1-3/16 |   |   |   |   |   |
| 2"                           | 03404                  | 25                    | .30               | 1-1/2  |   |   |   |   |   |
| 3"                           | 03405                  | 10                    | .81               | 1-7/8  |   |   |   |   |   |
| 4"                           | 03406                  | 5                     | 1.40              | 2-1/2  |   |   |   |   |   |

## TEE • CLEANOUT • W/CLEANOUT PLUG

ABS DWV

A444X

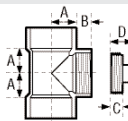

| CONNECTION<br><b>H x H x FPT</b> | CHARLOTTE STYLE<br>444-X | NIBCO STYLE<br>5814 | Dimensions        |        |     |     |       |   |   |
|----------------------------------|--------------------------|---------------------|-------------------|--------|-----|-----|-------|---|---|
| Size                             | Part<br>Number           | Ctn<br>Qty          | Approx<br>Net Wt. | A      | B   | C   | D     | E | F |
| 1-1/2"                           | 02997                    | 10                  | .24               | 1-3/16 | 5/8 | 5/8 | 1-3/8 |   |   |
| 2"                               | 02998                    | 10                  | .36               | 1-1/2  | 5/8 | 5/8 | 1-3/8 |   |   |
| 3"                               | 02999                    | 10                  | .93               | 1-7/8  | 3/4 | 3/4 | 1-3/4 |   |   |
| 4"                               | 03000                    | 5                   | 1.64              | 2-1/2  | 7/8 | 7/8 | 1-7/8 |   |   |

**TEE • FLUSH CLEANOUT**

**ABS DWV**

**A445**

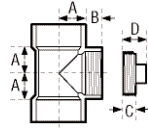

| CONNECTION<br><b>H x H x FPT</b> | CHARLOTTE STYLE |         |                | NIBCO STYLE |     |   | Dimensions |   |   |  |  |  |
|----------------------------------|-----------------|---------|----------------|-------------|-----|---|------------|---|---|--|--|--|
|                                  | Part Number     | Ctn Qty | Approx Net Wt. | A           | B   | C | D          | E | F |  |  |  |
| 1-1/2"                           | 03413           | 20      | .21            | 1-3/16      | 5/8 |   |            |   |   |  |  |  |
| 2"                               | 03414           | 20      | .30            | 1-1/2       | 5/8 |   |            |   |   |  |  |  |
| 3"                               | 03415           | 10      | .78            | 1-7/8       | 3/4 |   |            |   |   |  |  |  |
| 4"                               | 03416           | 10      | 1.38           | 2-1/2       | 7/8 |   |            |   |   |  |  |  |

**CLEANOUT • TWO WAY**

**ABS DWV**

**A448**

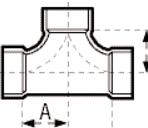

| CONNECTION<br><b>ALL HUB</b> | CHARLOTTE STYLE |         |                | NIBCO STYLE |   |   | Dimensions |   |   |  |  |  |
|------------------------------|-----------------|---------|----------------|-------------|---|---|------------|---|---|--|--|--|
|                              | Part Number     | Ctn Qty | Approx Net Wt. | A           | B | C | D          | E | F |  |  |  |
| 3"                           | 02237           | 10      | 1.42           | 4-1/16      |   |   |            |   |   |  |  |  |
| 4"                           | 02238           | 5       | 2.48           | 4-15/16     |   |   |            |   |   |  |  |  |

**TEE • FIXTURE**

**ABS DWV**

**A450**

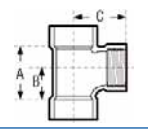

| CONNECTION<br><b>H x H x FPT</b> | CHARLOTTE STYLE |         |                | NIBCO STYLE |        |   | Dimensions |   |  |  |  |
|----------------------------------|-----------------|---------|----------------|-------------|--------|---|------------|---|--|--|--|
|                                  | Part Number     | Ctn Qty | Approx Net Wt. | A           | B      | C | D          | E |  |  |  |
| 1-1/2"                           | 03012           | 50      | .21            | 2-3/4       | 1-9/16 | 2 | 1-1/4      |   |  |  |  |
| 2" x 2" x 1-1/2"                 | 03402           | 25      | .24            | 2-3/4       | 1-7/16 | 2 | 1-1/4      |   |  |  |  |

**WYE • DOUBLE FIXTURE • STREET**

**ABS DWV**

**A499**

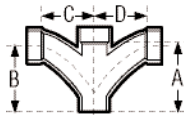

| CONNECTION<br><b>SP x H x H x H</b> | CHARLOTTE STYLE |         |                | NIBCO STYLE |       |         | Dimensions |   |  |  |  |
|-------------------------------------|-----------------|---------|----------------|-------------|-------|---------|------------|---|--|--|--|
|                                     | Part Number     | Ctn Qty | Approx Net Wt. | A           | B     | C       | D          | E |  |  |  |
| 3"                                  | 02245           | 5       | 1.78           | 8-1/4       | 5-3/4 | 4-15/16 | 4-15/16    |   |  |  |  |

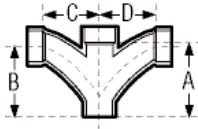

**WYE • DOUBLE FIXTURE****ABS DWV****A500**

| CONNECTION<br><b>ALL HUB</b>  | CHARLOTTE STYLE<br>500 |            |                   | NIBCO STYLE<br>5835-B |       |         |         |   |
|-------------------------------|------------------------|------------|-------------------|-----------------------|-------|---------|---------|---|
|                               | Part<br>Number         | Ctn<br>Qty | Approx<br>Net Wt. | Dimensions            |       |         |         |   |
| Size                          |                        |            |                   | A                     | B     | C       | D       | E |
| 2"                            | 02246                  | 25         | .62               | 4-5/8                 | 4-1/4 | 3-1/2   | 3-1/2   |   |
| 3"                            | 02249                  | 10         | .47               | 6-3/4                 | 6-1/4 | 4-15/16 | 4-15/16 |   |
| <b>REDUCING</b>               |                        |            |                   |                       |       |         |         |   |
| 2" x 1-1/2" x 1-1/2" x 1-1/2" | 02247                  | 20         | .42               | 3-1/2                 | 3-1/8 | 2-7/8   | 2-7/8   |   |
| 2" x 1-1/2" x 2" x 2"         | 02248                  | 25         | .58               | 4-5/8                 | 4-1/4 | 3-1/2   | 3-1/2   |   |
| 2" x 2" x 1-1/2" x 1-1/2"     | 02244                  | 20         | .50               | 3-1/4                 | 3     | 3-3/4   | 2-3/4   |   |
| 3" x 2" x 3" x 3"             | 02250                  | 5          | 1.70              | 6-3/4                 | 6-1/4 | 4-15/16 | 4-15/16 |   |

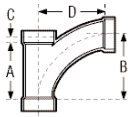
**COMBINATION WYE & 1/8 BEND-ONE PIECE****ABS DWV****A501**

| CONNECTION<br><b>ALL HUB</b> | CHARLOTTE STYLE<br>501 |            |                   | NIBCO STYLE<br>5812-LR |         |        |         |     |
|------------------------------|------------------------|------------|-------------------|------------------------|---------|--------|---------|-----|
|                              | Part<br>Number         | Ctn<br>Qty | Approx<br>Net Wt. | Dimensions             |         |        |         |     |
| Size                         |                        |            |                   | A                      | B       | C      | D       | E F |
| 1-1/2"                       | 02853                  | 50         | .32               | 3-1/2                  | 3-15/16 | 7-1/16 | 3-15/16 |     |
| 2"                           | 02858                  | 20         | .54               | 4-7/16                 | 5-1/8   | 1-1/16 | 5-1/8   |     |
| 3"                           | 02852                  | 10         | 1.64              | 6-1/2                  | 7-9/16  | 1-1/16 | 7-9/16  |     |
| 4"                           | 02860                  | 10         | 3.08              | 8-1/2                  | 10      | 1-1/2  | 10      |     |

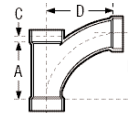
**COMBINATION WYE & 1/8 BEND • REDUCING • ONE PIECE****ABS DWV****A502**

| CONNECTION<br><b>ALL HUB</b> | CHARLOTTE STYLE<br>502 |            |                   | NIBCO STYLE<br>5812-LR |         |        |         |   |
|------------------------------|------------------------|------------|-------------------|------------------------|---------|--------|---------|---|
|                              | Part<br>Number         | Ctn<br>Qty | Approx<br>Net Wt. | Dimensions             |         |        |         |   |
| Size                         |                        |            |                   | A                      | B       | C      | D       | E |
| 2" x 1-1/2" x 1-1/2"         | 02835                  | 5          | .34               | 3-1/2                  | 3-15/16 | 7/16   | 4-3/16  |   |
| 2" x 1-1/2" x 2"             | 02836                  | 5          | .52               | 4-7/16                 | 5-1/8   | 1-1/16 | 5-1/8   |   |
| 2" x 2" x 1-1/2"             | 02865                  | 20         | .37               | 3-1/2                  | 3-15/16 | 7/16   | 4-3/16  |   |
| 3" x 3" x 1-1/2"             | 02837                  | 15         | .78               | 3-1/2                  | 3-15/16 | 7/16   | 4-3/4   |   |
| 3" x 3" x 2"                 | 02857                  | 10         | .95               | 4-7/16                 | 5-1/8   | 1-1/16 | 5-11/16 |   |
| 4" x 4" x 2"                 | 02863                  | 5          | 1.34              | 4-1/2                  | 5-1/8   | 5/8    | 6-1/8   |   |
| 4" x 4" x 3"                 | 02864                  | 5          | 2.08              | 6-1/2                  | 7-9/16  | 1-1/16 | 8-1/16  |   |

**COMBINATION WYE & 1/8 BEND • TWO PIECE**

**ABS DWV**

**A503**

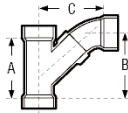
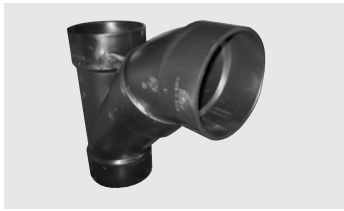

| CONNECTION     | CHARLOTTE STYLE |         |                | NIBCO STYLE |        |        | Dimensions |   |   |   |   |   |
|----------------|-----------------|---------|----------------|-------------|--------|--------|------------|---|---|---|---|---|
| <b>ALL HUB</b> | N/A             |         |                | N/A         |        |        | A          | B | C | D | E | F |
| Size           | Part Number     | Ctn Qty | Approx Net Wt. |             |        |        |            |   |   |   |   |   |
| 6"             | 02266           | 2       | 7.95           | 10          | 12-1/2 | 13-7/8 |            |   |   |   |   |   |

**COMBINATION WYE & 1/8 BEND • REDUCING • TWO PIECE**

**ABS DWV**

**A504**

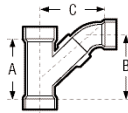

| CONNECTION     | CHARLOTTE STYLE |         |                | NIBCO STYLE |       |    | Dimensions |   |   |   |   |   |
|----------------|-----------------|---------|----------------|-------------|-------|----|------------|---|---|---|---|---|
| <b>ALL HUB</b> | 504             |         |                | N/A         |       |    | A          | B | C | D | E | F |
| Size           | Part Number     | Ctn Qty | Approx Net Wt. |             |       |    |            |   |   |   |   |   |
| 6" x 6" x 4"   | 02267           | 4       | 4.79           | 7           | 8-1/8 | 10 |            |   |   |   |   |   |

**DOUBLE COMBINATION WYE & 1/8 BEND**

**ABS DWV**

(THREE PIECE)

**A507**

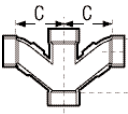

| CONNECTION     | CHARLOTTE STYLE |            |         | NIBCO STYLE |       |       | Dimensions |   |   |   |   |   |
|----------------|-----------------|------------|---------|-------------|-------|-------|------------|---|---|---|---|---|
| <b>ALL HUB</b> | N/A             |            |         | 5836        |       |       | A          | B | C | D | E | F |
| Part Size      | Ctn Number      | Approx Qty | Net Wt. |             |       |       |            |   |   |   |   |   |
| 3"             | 02854           | 5          | 2.49    | 6-1/2       | 7-3/8 | 7-3/8 |            |   |   |   |   |   |

**WYE**

**ABS DWV**

**A600**

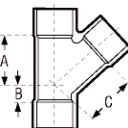

| CONNECTION     | CHARLOTTE STYLE |         |                | NIBCO STYLE |        |        | Dimensions |   |   |   |   |   |
|----------------|-----------------|---------|----------------|-------------|--------|--------|------------|---|---|---|---|---|
| <b>ALL HUB</b> | 600             |         |                | 5810        |        |        | A          | B | C | D | E | F |
| Size           | Part Number     | Ctn Qty | Approx Net Wt. |             |        |        |            |   |   |   |   |   |
| 1-1/4"         | 02816           | 35      | .23            | 2-9/16      | 1-1/16 | 2-9/16 |            |   |   |   |   |   |
| 1-1/2"         | 02822           | 50      | .29            | 2-7/8       | 1-1/8  | 2-7/8  |            |   |   |   |   |   |
| 2"             | 02823           | 25      | .44            | 3-5/8       | 1-3/8  | 3-5/8  |            |   |   |   |   |   |
| 3"             | 02824           | 25      | 1.26           | 5           | 1-5/8  | 5      |            |   |   |   |   |   |
| 4"             | 02825           | 5       | 2.29           | 6-3/8       | 1-7/8  | 6-3/8  |            |   |   |   |   |   |
| 6"             | 03135           | 4       | 6.05           | 8-7/16      | 1-3/4  | 8-7/16 |            |   |   |   |   |   |



## WYE • REDUCING

ABS DWV

## A601

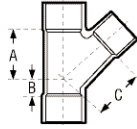

| CONNECTION<br><b>ALL HUB</b> | CHARLOTTE STYLE<br>601 |            |                   | NIBCO STYLE<br>5810 |        |                   |  |   |   |
|------------------------------|------------------------|------------|-------------------|---------------------|--------|-------------------|--|---|---|
|                              | Part<br>Number         | Ctn<br>Qty | Approx<br>Net Wt. | A                   | B      | Dimensions<br>C D |  | E | F |
| 2" x 1-1/2" x 1-1/2"         | 02831                  | 25         | .33               | 2-13/16             | 3/4    | 2-15/16           |  |   |   |
| 2" x 1-1/2" x 2"             | 02832                  | 10         | .47               | 3-1/2               | 1      | 3-3/8             |  |   |   |
| 2" x 2" x 1-1/2"             | 02826                  | 25         | .38               | 3-5/16              | 1-1/16 | 3-7/16            |  |   |   |
| 3" x 3" x 1-1/2"             | 02827                  | 15         | .78               | 3-3/4               | 1/2    | 4-5/16            |  |   |   |
| 3" x 3" x 2"                 | 02828                  | 25         | .87               | 4-1/8               | 7/8    | 4-5/8             |  |   |   |
| 4" x 4" x 1-1/2"             | 02833                  | 5          | 1.43              | 3-5/16              | 0      | 3-15/16           |  |   |   |
| 4" x 4" x 2"                 | 02829                  | 10         | 1.37              | 4-11/16             | 3/8    | 5-9/16            |  |   |   |
| 4" x 4" x 3"                 | 02830                  | 10         | 1.78              | 5-9/16              | 1-1/16 | 6                 |  |   |   |
| 6" x 6" x 4"                 | 03137                  | 5          | 3.44              | 6-11/16             | 3/16   | 7-7/16            |  |   |   |

## WYE • STREET

ABS DWV

## A602

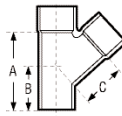

| CONNECTION<br><b>SP x H x H</b> | CHARLOTTE STYLE<br>602 |            |                   | NIBCO STYLE<br>5810-2 |         |                   |  |   |   |
|---------------------------------|------------------------|------------|-------------------|-----------------------|---------|-------------------|--|---|---|
|                                 | Part<br>Number         | Ctn<br>Qty | Approx<br>Net Wt. | A                     | B       | Dimensions<br>C D |  | E | F |
| 1-1/2"                          | 03367                  | 50         | .28               | 2-7/8                 | 1-13/16 | 2-7/8             |  |   |   |
| 2"                              | 03368                  | 30         | .43               | 3-5/8                 | 2-1/8   | 3-5/8             |  |   |   |
| 3"                              | 03369                  | 10         | 1.23              | 5                     | 3-1/8   | 5                 |  |   |   |
| 4"                              | 03370                  | 5          | 2.24              | 6-3/8                 | 3-5/8   | 6-3/8             |  |   |   |

## WYE • STREET • REDUCING

ABS DWV

## A603

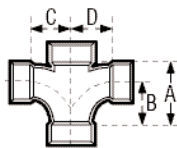

| CONNECTION<br><b>SP x H x H</b> | CHARLOTTE STYLE<br>603 |            |                   | NIBCO STYLE<br>5810-2 |         |                   |  |   |   |
|---------------------------------|------------------------|------------|-------------------|-----------------------|---------|-------------------|--|---|---|
|                                 | Part<br>Number         | Ctn<br>Qty | Approx<br>Net Wt. | A                     | B       | Dimensions<br>C D |  | E | F |
| 3" x 3" x 1-1/2"                | 03372                  | 20         | .76               | 3-3/4                 | 2       | 4-5/16            |  |   |   |
| 3" x 3" x 2"                    | 03373                  | 30         | .84               | 4-1/8                 | 2-3/8   | 4-5/8             |  |   |   |
| 4" x 4" x 2"                    | 03374                  | 10         | 1.31              | 4-11/16               | 2-1/8   | 5-9/16            |  |   |   |
| 4" x 4" x 3"                    | 03375                  | 10         | 1.72              | 5-9/16                | 2-13/16 | 6                 |  |   |   |

**WYE • CLEANOUT**

**ABS DWV**

**A604**

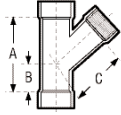

| CONNECTION<br><b>H x H x FPT</b> | CHARLOTTE STYLE<br>N/A |             |         | NIBCO STYLE<br>N/A |       | Dimensions |   |   |   |  |
|----------------------------------|------------------------|-------------|---------|--------------------|-------|------------|---|---|---|--|
|                                  | Size                   | Part Number | Ctn Qty | Approx Net Wt.     | A     | B          | C | D | E |  |
| 1-1/2"                           | 03019                  | 20          | .285    | 4                  | 1-1/8 | 2-7/8      |   |   |   |  |

**WYE • CLEANOUT • W/CLEANOUT PLUG**

**ABS DWV**

**A604X**

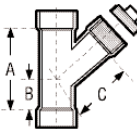

| CONNECTION<br><b>H x H x FPT</b> | CHARLOTTE STYLE<br>N/A |             |         | NIBCO STYLE<br>N/A |       | Dimensions |   |   |   |  |
|----------------------------------|------------------------|-------------|---------|--------------------|-------|------------|---|---|---|--|
|                                  | Size                   | Part Number | Ctn Qty | Approx Net Wt.     | A     | B          | C | D | E |  |
| 1-1/2"                           | 02809                  | 20          | .35     | 4                  | 1-1/8 | 2-7/8      |   |   |   |  |

**WYE • DOUBLE**

**ABS DWV**

**A611**

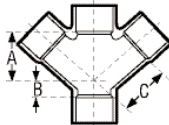

| CONNECTION<br><b>ALL HUB</b> | CHARLOTTE STYLE<br>611 |             |         | NIBCO STYLE<br>5834 |       | Dimensions |   |   |   |  |
|------------------------------|------------------------|-------------|---------|---------------------|-------|------------|---|---|---|--|
|                              | Size                   | Part Number | Ctn Qty | Approx Net Wt.      | A     | B          | C | D | E |  |
| 1-1/2"                       | 02838                  | 40          | .37     | 2-7/8               | 1-1/8 | 2-7/8      |   |   |   |  |
| 2"                           | 02839                  | 20          | .55     | 3-5/8               | 1-3/8 | 3-5/8      |   |   |   |  |
| 3"                           | 02840                  | 10          | 1.66    | 5                   | 1-5/8 | 5          |   |   |   |  |
| 4"                           | 02841                  | 5           | 2.88    | 6-3/8               | 1-7/8 | 6-3/8      |   |   |   |  |

TUBE & PIPE

METAL FITTINGS & NIPPLES

PLASTIC FITTINGS

VALVES

FILTER-DRYERS & STRAINERS



## WYE • DOUBLE • REDUCING

ABS DWV

## A612

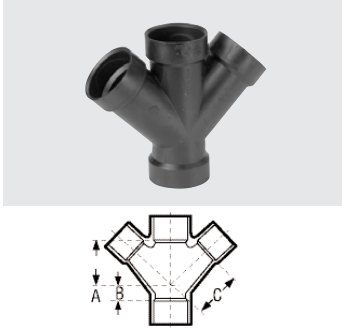

| CONNECTION<br><b>ALL HUB</b> | CHARLOTTE STYLE |         | NIBCO STYLE    |         | Dimensions |        |   |   |  |
|------------------------------|-----------------|---------|----------------|---------|------------|--------|---|---|--|
|                              | Part Number     | Ctn Qty | Approx Net Wt. | A       | B          | C      | D | E |  |
| 2" x 2" x 1-1/2" x 1-1/2"    | 02847           | 10      | .45            | 3-5/16  | 1-1/16     | 3-7/16 |   |   |  |
| 3" x 3" x 1-1/2" x 1-1/2"    | 02843           | 10      | .81            | 3-3/4   | 1/2        | 4-5/16 |   |   |  |
| 3" x 3" x 2" x 2"            | 02844           | 10      | .95            | 4-1/8   | 7/8        | 4-5/8  |   |   |  |
| 4" x 4" x 2" x 2"            | 02845           | 5       | 1.46           | 4-11/16 | 3/8        | 5-9/16 |   |   |  |
| 4" x 4" x 3" x 3"            | 02846           | 5       | 2.10           | 5-9/16  | 1-1/16     | 6      |   |   |  |
| 6" x 6" x 4" x 4"            | 03142           | 3       | 4.08           | 6-11/16 | 3/16       | 7-7/16 |   |   |  |

## RETURN BEND

ABS DWV

## A700

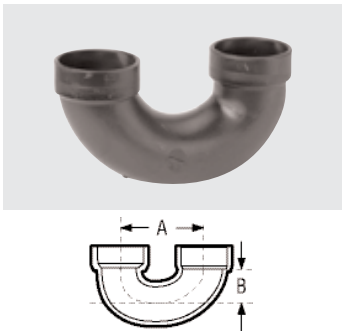

| CONNECTION<br><b>H x H</b> | CHARLOTTE STYLE |         | NIBCO STYLE    |        | Dimensions |   |   |   |  |
|----------------------------|-----------------|---------|----------------|--------|------------|---|---|---|--|
|                            | Part Number     | Ctn Qty | Approx Net Wt. | A      | B          | C | D | E |  |
| 1-1/2"                     | 03466           | 20      | .24            | 3-1/2  | 1-17/32    |   |   |   |  |
| 2"                         | 03467           | 35      | .44            | 5-1/4  | 2-3/8      |   |   |   |  |
| 3"                         | 03468           | 10      | 1.30           | 6-3/4  | 3          |   |   |   |  |
| 4"                         | 03469           | 5       | 2.31           | 8-9/16 | 3-11/16    |   |   |   |  |

## RETURN BEND • W/CLEANOUT

ABS DWV

## A701

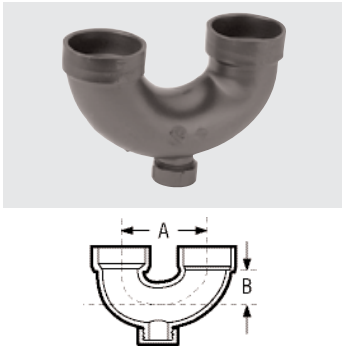

| CONNECTION<br><b>H x H</b> | CHARLOTTE STYLE |         | NIBCO STYLE    |        | Dimensions |   |   |   |  |
|----------------------------|-----------------|---------|----------------|--------|------------|---|---|---|--|
|                            | Part Number     | Ctn Qty | Approx Net Wt. | A      | B          | C | D | E |  |
| 1-1/2"                     | 03471           | 20      | .26            | 3-1/16 | 1-3/8      |   |   |   |  |
| 2"                         | 03472           | 10      | .49            | 5-1/32 | 2-1/4      |   |   |   |  |

## ADAPTER • TAIL PIECE • W/ PLASTIC NUT

ABS DWV

## A704P

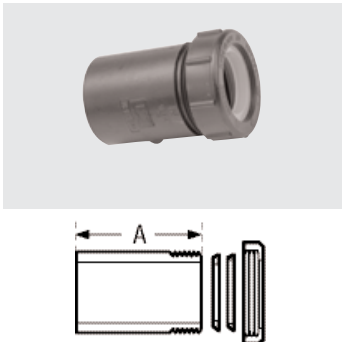

| CONNECTION<br><b>SP x SJ</b> | CHARLOTTE STYLE |         | NIBCO STYLE    |       | Dimensions |   |   |   |  |
|------------------------------|-----------------|---------|----------------|-------|------------|---|---|---|--|
|                              | Part Number     | Ctn Qty | Approx Net Wt. | A     | B          | C | D | E |  |
| 1-1/2" x 1-1/2"              | 02975           | 25      | .10            | 2-5/8 |            |   |   |   |  |
| OR<br>1-1/2" x 1-1/4"        | 02975           | 25      | .10            | 2-5/8 |            |   |   |   |  |

(Furnished with both sizes S] washers)

**P-TRAP • W/SOLVENT WELD JOINT**

**ABS DWV**

**A706X**

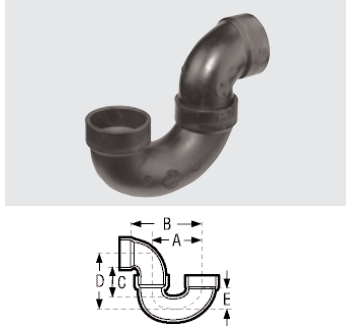

| CONNECTION<br><b>H x H</b> | CHARLOTTE STYLE<br>706-X |         |                | NIBCO STYLE<br>5885 |         | Dimensions |        |         |  |  |
|----------------------------|--------------------------|---------|----------------|---------------------|---------|------------|--------|---------|--|--|
|                            | Part Number              | Ctn Qty | Approx Net Wt. | A                   | B       | C          | D      | E       |  |  |
| 1-1/2"                     | 02214                    | 25      | .38            | 3-1/2               | 4-23/32 | 2-11/32    | 3-5/8  | 1-17/32 |  |  |
| 2"                         | 02222                    | 20      | .64            | 5-1/4               | 6-7/8   | 2-7/8      | 5-1/8  | 2-3/8   |  |  |
| 3"                         | 02230                    | 10      | 1.97           | 6-3/4               | 9-15/16 | 4-11/16    | 7-5/8  | 3       |  |  |
| 4"                         | 02231                    | 4       | 3.47           | 8-9/16              | 12-7/16 | 5-1/4      | 7-9/16 | 3-11/16 |  |  |

**P-TRAP • W/SOLVENT WELD JOINT & CLEANOUT**

**ABS DWV**

**A707X**

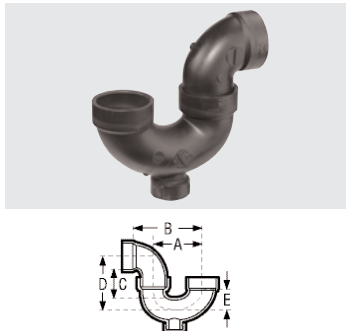

| CONNECTION<br><b>H x H</b> | CHARLOTTE STYLE<br>707-X |         |                | NIBCO STYLE<br>5884 |        | Dimensions |       |       |   |  |  |
|----------------------------|--------------------------|---------|----------------|---------------------|--------|------------|-------|-------|---|--|--|
|                            | Part Number              | Ctn Qty | Approx Net Wt. | A                   | B      | C          | D     | E     | F |  |  |
| 1-1/2"                     | 02223                    | 10      | .40            | 3-11/16             | 4-9/32 | 2-1/8      | 3-5/8 | 1-3/8 |   |  |  |
| 2"                         | 02224                    | 10      | .65            | 5-1/32              | 6-3/8  | 2-1/2      | 5     | 2-1/4 |   |  |  |

**P-TRAP • W/UNION**

**ABS DWV**

**A708P**

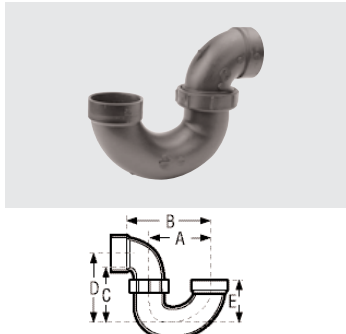

| CONNECTION<br><b>H x H</b> | CHARLOTTE STYLE<br>708-P |         |                | NIBCO STYLE<br>5895 |         | Dimensions |       |         |   |  |  |
|----------------------------|--------------------------|---------|----------------|---------------------|---------|------------|-------|---------|---|--|--|
|                            | Part Number              | Ctn Qty | Approx Net Wt. | A                   | B       | C          | D     | E       | F |  |  |
| 1-1/4"                     | 02212                    | 50      | .38            | 3                   | 4-1/8   | 2-1/16     | 3-3/8 | 1-3/8   |   |  |  |
| 1-1/2"                     | 02215                    | 25      | .42            | 3-1/2               | 4-23/32 | 2-11/32    | 3-5/8 | 1-17/32 |   |  |  |
| 2"                         | 02216                    | 20      | .69            | 5-1/4               | 6-7/8   | 2-7/8      | 5-1/8 | 2-3/8   |   |  |  |

**P-TRAP • LOW PROFILE W/SOLVENT WELD JOINT**

**ABS DWV**

**A710**

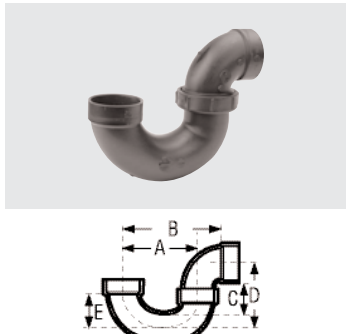

| CONNECTION<br><b>H x H</b> | CHARLOTTE STYLE<br>N/A |         |                | NIBCO STYLE<br>N/A |   | Dimensions |   |   |   |  |  |
|----------------------------|------------------------|---------|----------------|--------------------|---|------------|---|---|---|--|--|
|                            | Part Number            | Ctn Qty | Approx Net Wt. | A                  | B | C          | D | E | F |  |  |
| 2"                         | 02225                  | 20      | .64            |                    |   |            |   |   |   |  |  |

TUBE & PIPE

METAL FITTINGS & NIPPLES

PLASTIC FITTINGS

VALVES

FILTER-DRYERS & STRAINERS



## LA-TRAP • W/UNION &amp; ONE-PIECE POLY NUT

ABS DWV

## A711M

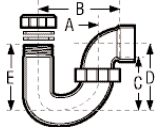

| CONNECTION<br>SJ x H | CHARLOTTE STYLE |         | NIBCO STYLE    |         | Dimensions |       |   |   |  |
|----------------------|-----------------|---------|----------------|---------|------------|-------|---|---|--|
|                      | Part Number     | Ctn Qty | Approx Net Wt. | A       | B          | C     | D | E |  |
| 1-1/4" x 1-1/2"      | 02219           | 25      | .51            | 3-13/16 | 5          | 2-1/2 | 4 | 4 |  |
| 1-1/2"               | 02221           | 25      | .51            | 3-13/16 | 5          | 2-1/2 | 4 | 4 |  |

(W/Plastic Nut &amp; Both 1-1/4" and 1-1/2" Washer)

## LA P-TRAP • W/UNION &amp; 1-1/2" &amp; 1-1/4" SJ WASHER - PLASTIC NUT

ABS DWV

(W/Plastic Nut &amp; Both 1-1/4" &amp; 1-1/2" Washer)

## A711P

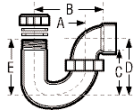

| CONNECTION<br>SJ x H | CHARLOTTE STYLE |         | NIBCO STYLE    |         | Dimensions |       |   |   |  |
|----------------------|-----------------|---------|----------------|---------|------------|-------|---|---|--|
|                      | Part Number     | Ctn Qty | Approx Net Wt. | A       | B          | C     | D | E |  |
| 1-1/4" x 1-1/2"      | 02220           | 25      | .51            | 3-13/16 | 5          | 2-1/2 | 4 | 4 |  |
| 1-1/2" x 1-1/2"      |                 |         |                |         |            |       |   |   |  |

(\* Top of Nut)

## DRUM TRAP • W/CLEANOUT

ABS DWV

## A720X

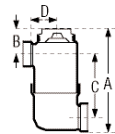

| CONNECTION<br>H x H | CHARLOTTE STYLE |         | NIBCO STYLE    |         | Dimensions |       |       |   |   |  |
|---------------------|-----------------|---------|----------------|---------|------------|-------|-------|---|---|--|
|                     | Part Number     | Ctn Qty | Approx Net Wt. | A       | B          | C     | D     | E | F |  |
| 3" x 6" x 1-1/2"    | 03100           | 10      | 1.20           | 7-13/16 | 3          | 4-1/2 | 1-1/2 |   |   |  |

(W/Plug)

## CLOSET FLANGE

ABS DWV

(One Piece W/ Slots)

## A800

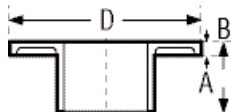

| CONNECTION<br>H | CHARLOTTE STYLE |         | NIBCO STYLE    |      | Dimensions |   |   |   |   |  |
|-----------------|-----------------|---------|----------------|------|------------|---|---|---|---|--|
|                 | Part Number     | Ctn Qty | Approx Net Wt. | A    | B          | C | D | E | F |  |
| 4"              | 02902           | 25      | .50            | 7/16 | -          | 2 | 7 |   |   |  |

**CLOSET FLANGE • W/STOP**

**ABS DWV**

**A800S**

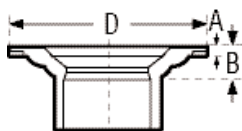

| CONNECTION<br><b>H</b> | CHARLOTTE STYLE<br>800-S |         |                | NIBCO STYLE<br>5851 |       |   | Dimensions |   |   |  |
|------------------------|--------------------------|---------|----------------|---------------------|-------|---|------------|---|---|--|
| Size                   | Part Number              | Ctn Qty | Approx Net Wt. | A                   | B     | C | D          | E | F |  |
| 4" x 3"                | 02903                    | 25      | .59            | 7/16                | 1-1/4 | — | 7          |   |   |  |

**CLOSET FLANGE • KNOCKOUT**

**ABS DWV**

(One Piece W/Slots & Knockout Test Cap) **A800KO**

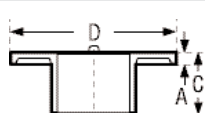
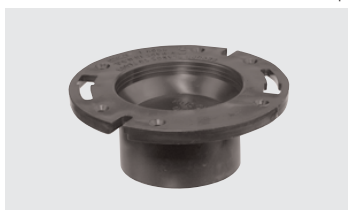

| CONNECTION<br><b>H</b> | CHARLOTTE STYLE<br>800-KO |         |                | NIBCO STYLE<br>5855 |       |   | Dimensions |   |   |  |
|------------------------|---------------------------|---------|----------------|---------------------|-------|---|------------|---|---|--|
| Size                   | Part Number               | Ctn Qty | Approx Net Wt. | A                   | B     | C | D          | E | F |  |
| 4"                     | 02253                     | 25      | .54            | 7/16                | —     | 2 | 7          |   |   |  |
| 4" x 3"                | 02254                     | 25      | .58            | 7/16                | 1-1/4 | — | 7          |   |   |  |

**CLOSET FLANGE • SPIGOT • REDUCING**

**ABS DWV**

(One Piece W/Slots)

**A801**

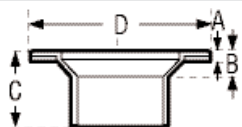

| CONNECTION<br><b>SP</b> | CHARLOTTE STYLE<br>801 |         |                | NIBCO STYLE<br>5851-2 |       |       | Dimensions |   |   |  |
|-------------------------|------------------------|---------|----------------|-----------------------|-------|-------|------------|---|---|--|
| Size                    | Part Number            | Ctn Qty | Approx Net Wt. | A                     | B     | C     | D          | E | F |  |
| 4" x 3"                 | 02919                  | 25      | .53            | 7/16                  | 1-1/4 | 2-3/4 | 7          |   |   |  |

**CLOSET FLANGE • W/GUSSET**

**ABS DWV**

(One Piece W/Slots)

**A802**

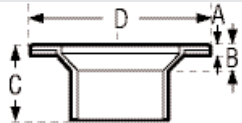

| CONNECTION<br><b>H</b> | CHARLOTTE STYLE<br>N/A |         |                | NIBCO STYLE<br>N/A |   |   | Dimensions |   |   |  |
|------------------------|------------------------|---------|----------------|--------------------|---|---|------------|---|---|--|
| Size                   | Part Number            | Ctn Qty | Approx Net Wt. | A                  | B | C | D          | E | F |  |
| 4"                     | 02262                  | 25      | .51            | 7/16               | — | 2 | 7          |   |   |  |



**CLOSET FLANGE • FEMALE****ABS DWV**

(W/O Slots)

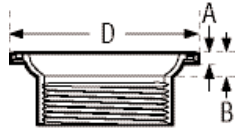
**A807**CONNECTION  
**FPT**CHARLOTTE STYLE  
N/ANIBCO STYLE  
5851-3

| Size    | Part Number | Ctn Qty | Approx Net Wt. | Dimensions |       |   |   |   |   |
|---------|-------------|---------|----------------|------------|-------|---|---|---|---|
|         |             |         |                | A          | B     | C | D | E | F |
| 4" x 3" | 02270       | 25      | .47            | 7/16       | 1-1/4 | — | 7 |   |   |

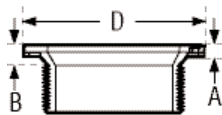
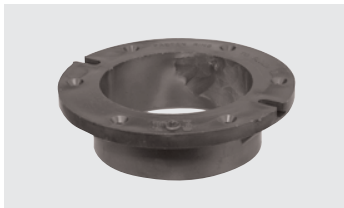
**CLOSET FLANGE • MALE****ABS DWV****A808**CONNECTION  
**MPT**CHARLOTTE STYLE  
N/ANIBCO STYLE  
5851-4

| Size    | Part Number | Ctn Qty | Approx Net Wt. | Dimensions |       |   |   |   |   |
|---------|-------------|---------|----------------|------------|-------|---|---|---|---|
|         |             |         |                | A          | B     | C | D | E | F |
| 4" x 3" | 02260       | 25      | .43            | 7/16       | 1-1/4 | — | 7 |   |   |

**CLOSET FLANGE • ADJUSTABLE W/PLASTIC RING****ABS DWV**

(W/Slots &amp; Plastic Ring)

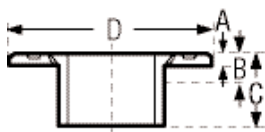
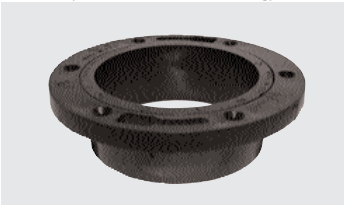
**A810**CONNECTION  
**H**CHARLOTTE STYLE  
811-PNIBCO STYLE  
N/A

| Size | Part Number | Ctn Qty | Approx Net Wt. | Dimensions |   |       |   |   |   |
|------|-------------|---------|----------------|------------|---|-------|---|---|---|
|      |             |         |                | A          | B | C     | D | E | F |
| 4"   | 02256       | 25      | .48            | 1/2        | — | 2-1/4 | 7 |   |   |

**CLOSET FLANGE • W/PIPE STOP • ADJUSTABLE • W/PLASTIC RING****ABS DWV**

(W/Pipe stop, slots &amp; plastic ring)

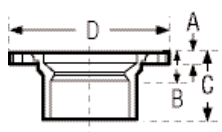
**A810S**CONNECTION  
**H**CHARLOTTE STYLE  
811-PNIBCO STYLE  
N/A

| Size    | Part Number | Ctn Qty | Approx Net Wt. | Dimensions |       |       |   |   |   |
|---------|-------------|---------|----------------|------------|-------|-------|---|---|---|
|         |             |         |                | A          | B     | C     | D | E | F |
| 4" x 3" | 02251       | 25      | .50            | 1/2        | 1-1/4 | 2-3/4 | 7 |   |   |

**CLOSET FLANGE • ADJUSTABLE • W/METAL RING-EPOXY COATED**

**ABS DWV**

**A811**

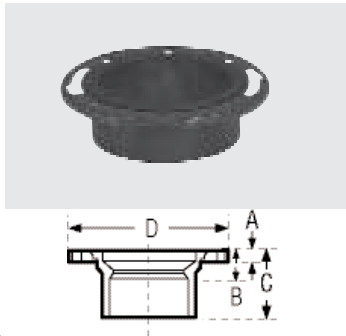

| CONNECTION<br><b>H</b> | CHARLOTTE STYLE<br>811 |         |                | NIBCO STYLE<br>5851-A |       |       | Dimensions |   |   |  |
|------------------------|------------------------|---------|----------------|-----------------------|-------|-------|------------|---|---|--|
|                        | Part Number            | Ctn Qty | Approx Net Wt. | A                     | B     | C     | D          | E | F |  |
| 4"                     | 02226                  | 25      | .60            | 5/16                  | —     | 2     | 7          |   |   |  |
| 4" x 3"                | 02227                  | 25      | .71            | 5/16                  | 1-1/4 | 2-3/4 | 7          |   |   |  |

**CLOSET FLANGE-SPIGOT • ADJUSTABLE • W/METAL RING-EPOXY COATED**

**ABS DWV**

**A812**

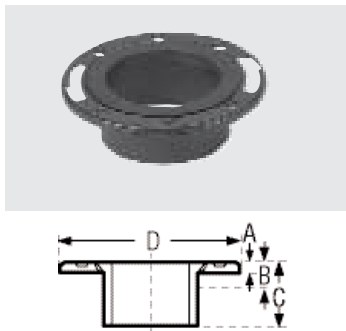

| CONNECTION<br><b>SP</b> | CHARLOTTE STYLE<br>812 |         |                | NIBCO STYLE<br>5851-2-A |       |       | Dimensions |   |   |  |
|-------------------------|------------------------|---------|----------------|-------------------------|-------|-------|------------|---|---|--|
|                         | Part Number            | Ctn Qty | Approx Net Wt. | A                       | B     | C     | D          | E | F |  |
| 4"                      | 02229                  | 25      | .85            | 5/16                    | —     | 2-1/4 | 7          |   |   |  |
| 4" x 3"                 | 02228                  | 25      | .67            | 5/16                    | 1-1/4 | 2-3/4 | 7          |   |   |  |

**CLOSET FLANGE • SPIGOT • ADJUSTABLE • W/PLASTIC RING**

**ABS DWV**

**A812P**

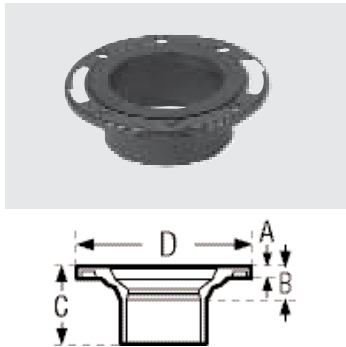

| CONNECTION<br><b>SP</b> | CHARLOTTE STYLE<br>812-P |         |                | NIBCO STYLE<br>N/A |       |       | Dimensions |   |   |  |
|-------------------------|--------------------------|---------|----------------|--------------------|-------|-------|------------|---|---|--|
|                         | Part Number              | Ctn Qty | Approx Net Wt. | A                  | B     | C     | D          | E | F |  |
| 4" x 3"                 | 02252                    | 25      | .46            | 1/2                | 1-1/4 | 2-3/4 | 7          |   |   |  |
| 4"                      | 02264                    | 25      | .56            | 1/2                | —     | 2-1/4 | 7          |   |   |  |

**FLUSH CLOSET FLANGE**

**ABS DWV**

(Fits Over 3" or inside 4" Sch 40 DWV Pipe) **A815**

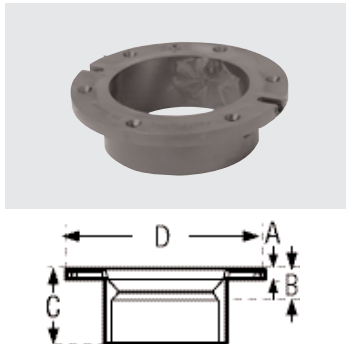

| CONNECTION<br><b>SP x H</b> | CHARLOTTE STYLE<br>815 |         |                | NIBCO STYLE<br>5853 |       |       | Dimensions |   |   |  |
|-----------------------------|------------------------|---------|----------------|---------------------|-------|-------|------------|---|---|--|
|                             | Part Number            | Ctn Qty | Approx Net Wt. | A                   | B     | C     | D          | E | F |  |
| 4"                          | 02255                  | 25      | .48            | 7/16                | 1-1/4 | 2-3/4 | 7          |   |   |  |
| OR<br>4" x 3"               |                        |         |                |                     |       |       |            |   |   |  |



## OFFSET CLOSET FLANGE • ADJUSTABLE W/METAL RING • EPOXY COATED

ABS DWV

A820

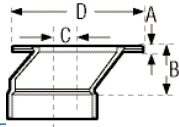

| CONNECTION | CHARLOTTE STYLE |         | NIBCO STYLE    |      | Dimensions |       |   |   |   |   |
|------------|-----------------|---------|----------------|------|------------|-------|---|---|---|---|
| <b>H</b>   | 820             |         | 5848-A         |      | A          | B     | C | D | E | F |
| Size       | Part Number     | Ctn Qty | Approx Net Wt. |      |            |       |   |   |   |   |
| 4" x 3"    | 02920           | 25      | .89            | 5/16 | 2-3/4      | 1-1/2 | 7 |   |   |   |

## SWIVEL TRAY PLUG ADAPTER • W/WASHER

ABS DWV

(W/Rubber Washer)

A900

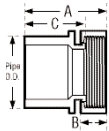
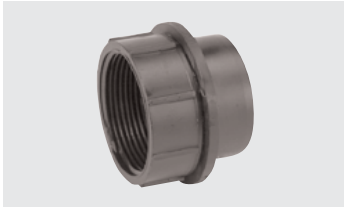

| CONNECTION                | CHARLOTTE STYLE |         | NIBCO STYLE    |       | Dimensions |       |   |   |   |   |
|---------------------------|-----------------|---------|----------------|-------|------------|-------|---|---|---|---|
| <b>SP x NPSM Threaded</b> | 900             |         | 5803-2-SW      |       | A          | B     | C | D | E | F |
| Size                      | Part Number     | Ctn Qty | Approx Net Wt. |       |            |       |   |   |   |   |
| 1-1/2"                    | 03418           | 50      | .071           | 21/32 | 11/16      | 19/32 |   |   |   |   |

## SWIVEL TRAY PLUG ADAPTER EXTENDED SPIGOT • W/WASHER

ABS DWV

(W/Rubber Washer)

A900X

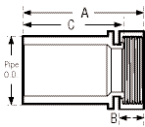

| CONNECTION                | CHARLOTTE STYLE |         | NIBCO STYLE    |         | Dimensions |         |   |   |   |   |
|---------------------------|-----------------|---------|----------------|---------|------------|---------|---|---|---|---|
| <b>SP x NPSM Threaded</b> | N/A             |         | N/A            |         | A          | B       | C | D | E | F |
| Size                      | Part Number     | Ctn Qty | Approx Net Wt. |         |            |         |   |   |   |   |
| 1-1/2"                    | 03013           | 50      | .10            | 2-13/32 | 3/4        | 1       |   |   |   |   |
| 1-1/4" x 1-1/2"           | 03420           | 50      | .09            | 2-13/32 | 11/16      | 1-15/16 |   |   |   |   |

## SWIVEL TRAY PLUG ADAPTER • W/WASHER

ABS DWV

(W/Rubber Washer)

A910

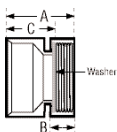

| CONNECTION               | CHARLOTTE STYLE |         | NIBCO STYLE    |         | Dimensions |       |   |   |   |   |
|--------------------------|-----------------|---------|----------------|---------|------------|-------|---|---|---|---|
| <b>H x NPSM Threaded</b> | 910             |         | 5803-SW        |         | A          | B     | C | D | E | F |
| Size                     | Part Number     | Ctn Qty | Approx Net Wt. |         |            |       |   |   |   |   |
| 1-1/2"                   | 03421           | 50      | .09            | 1-23/32 | 11/16      | 19/32 |   |   |   |   |
| <b>REDUCING</b>          |                 |         |                |         |            |       |   |   |   |   |
| 1-1/4" x 1-1/2"          | 03417           | 50      | .08            | 1-23/32 | 11/16      | 19/32 |   |   |   |   |

# PVC DWV Fittings



Mueller's PVC DWV fittings are made to the most exacting specifications to ensure the very best fit in the industry. Each fitting offers excellent rigidity, corrosion and chemical resistance while smooth walls prevent scaling and provide for free flow. Our precise manufacturing processes and stringent quality control ensure that our fittings perform flawlessly piece after piece. Fittings are packaged to common industry carton quantities and dimensions plus utilize an intuitive, recognizable style number system.

- Meets ASTM standard D2665 and D3311
- Made in the USA



TUBE & PIPE

METAL FITTINGS & NIPPLES

PLASTIC FITTINGS

VALVES

FILTER-DRIERS & STRAINERS

## COUPLING

## PVC DWV

### PI00

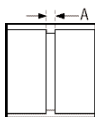

| CONNECTION<br><b>H x H</b> | CHARLOTTE STYLE<br>100 |         | NIBCO STYLE<br>4801 |            | LASCO STYLE<br>D100 |   |   |   |   |
|----------------------------|------------------------|---------|---------------------|------------|---------------------|---|---|---|---|
| Size                       | Part Number            | Ctn Qty | Approx Net Wt.      | Dimensions |                     |   |   |   |   |
|                            |                        |         |                     | A          | B                   | C | D | E | F |
| 1-1/4"                     | 05932                  | 100     | .07                 | 1/8        |                     |   |   |   |   |
| 1-1/2"                     | 05933                  | 100     | .09                 | 1/8        |                     |   |   |   |   |
| 2"                         | 05934                  | 100     | .14                 | 1/8        |                     |   |   |   |   |
| 3"                         | 05935                  | 60      | .45                 | 3/16       |                     |   |   |   |   |
| 4"                         | 05936                  | 25      | .80                 | 1/4        |                     |   |   |   |   |
| 6"                         | 06143                  | 15      | 2.14                | 1/4        |                     |   |   |   |   |
| 8"                         | 06145                  | 4       | 6.41                | 1/4        |                     |   |   |   |   |

## ADAPTER • FEMALE

## PVC DWV

### PI01

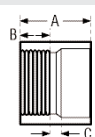

| CONNECTION<br><b>FPT x H</b> | CHARLOTTE STYLE<br>101 |         | NIBCO STYLE<br>4803 |            | LASCO STYLE<br>D101 |       |   |   |   |
|------------------------------|------------------------|---------|---------------------|------------|---------------------|-------|---|---|---|
| Size                         | Part Number            | Ctn Qty | Approx Net Wt.      | Dimensions |                     |       |   |   |   |
|                              |                        |         |                     | A          | B                   | C     | D | E | F |
| 1-1/4"                       | 05868                  | 50      | .10                 | 1-5/8      | 15/16               | 1/4   |   |   |   |
| 1-1/2"                       | 05866                  | 100     | .10                 | 1-5/8      | 15/16               | 1/4   |   |   |   |
| 2"                           | 05867                  | 100     | .15                 | 1-7/8      | 1                   | 1/4   |   |   |   |
| 3"                           | 05869                  | 30      | .49                 | 3-1/32     | 1-27/32             | 15/16 |   |   |   |
| 4"                           | 06396                  | 10      | .78                 | 3-3/32     | 1-15/16             | 11/32 |   |   |   |
| 6"                           | 06147                  | 10      | 1.64                | 4-3/4      | 1-3/4               | 1/4   |   |   |   |



## PIPE INCREASER/REDUCER

PVC DWV

## PI02

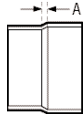
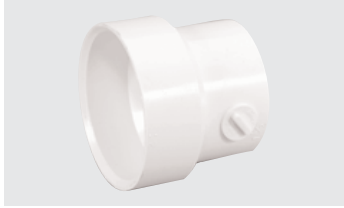

| CONNECTION<br>H x H | CHARLOTTE STYLE<br>102 | NIBCO STYLE<br>N/A | LASCO STYLE<br>D102 | Dimensions |   |   |   |   |   |
|---------------------|------------------------|--------------------|---------------------|------------|---|---|---|---|---|
| Size                | Part<br>Number         | Ctn<br>Qty         | Approx<br>Net Wt.   | A          | B | C | D | E | F |
| 2" x 1-1/2"         | 05948                  | 25                 | .15                 | 17/32      |   |   |   |   |   |
| 3" x 1-1/2"         | 05949                  | 25                 | .41                 | 1-7/16     |   |   |   |   |   |
| 3" x 2"             | 05950                  | 20                 | .15                 | 17/32      |   |   |   |   |   |
| 4" x 2"             | 05951                  | 10                 | .70                 | 1-3/8      |   |   |   |   |   |
| 4" x 3"             | 05952                  | 20                 | .76                 | 5/8        |   |   |   |   |   |
| 6" x 4"             | 05981                  | 5                  | 1.92                | 1-1/8      |   |   |   |   |   |

## ADAPTER • TRAP • MALE W/ONE-PIECE POLY NUT

PVC DWV

## PI03P

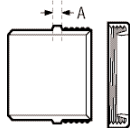

| CONNECTION<br>SP x SJ | CHARLOTTE STYLE<br>103P  | NIBCO STYLE<br>N/A | LASCO STYLE<br>N/A | Dimensions |   |   |   |   |   |
|-----------------------|--------------------------|--------------------|--------------------|------------|---|---|---|---|---|
| Ctn<br>Size           | Part<br>Approx<br>Number | Qty                | Net Wt.            | A          | B | C | D | E | F |
| 1-1/4"                | 06309                    | 50                 | .12                | 3/16       |   |   |   |   |   |
| 1-1/2"                | 06393                    | 50                 | .11                | 3/16       |   |   |   |   |   |
| 1-1/2" x 1-1/4"       | 06379                    | 75                 | .11                | 3/16       |   |   |   |   |   |

## ADAPTER • TRAP • MALE W/PLASTIC NUT &amp; BOTH 1-1/2 &amp; 1-1/4 WASHERS

PVC DWV

## PI03R

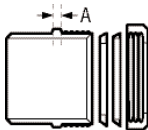

| CONNECTION<br>SP x SJ                    | CHARLOTTE STYLE<br>103R | NIBCO STYLE<br>N/A | LASCO STYLE<br>N/A | Dimensions |   |   |   |   |   |
|--|-------------------------|--------------------|--------------------|------------|---|---|---|---|---|
| Size                                     | Part<br>Number          | Ctn<br>Qty         | Approx<br>Net Wt.  | A          | B | C | D | E | F |
| 1-1/2" x 1-1/4"<br>OR<br>1-1/2" x 1-1/2" | 06389                   | 50                 | .14                | 3/16       |   |   |   |   |   |

## ADAPTER • TRAP • MALE W/PLASTIC NUT &amp; WASHER

PVC DWV

## PI03W

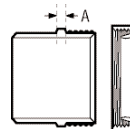

| CONNECTION<br>SP x SJ | CHARLOTTE STYLE<br>N/A | NIBCO STYLE<br>4801-2-7 | LASCO STYLE<br>D113 | Dimensions |   |   |   |   |   |
|-----------------------|------------------------|-------------------------|---------------------|------------|---|---|---|---|---|
| Size                  | Part<br>Number         | Ctn<br>Qty              | Approx<br>Net Wt.   | A          | B | C | D | E | F |
| 1-1/4"                | 06308                  | 50                      | .11                 | 3/16       |   |   |   |   |   |
| 1-1/2"                | 06410                  | 50                      | .11                 | 3/16       |   |   |   |   |   |
| 1-1/2" x 1-1/4"       | 06409                  | 50                      | .11                 | 3/16       |   |   |   |   |   |
| 2"                    | 06930                  | 25                      | .17                 | 3/16       |   |   |   |   |   |

**ADAPTER • TRAP • MALE CHROME NUT & WASHER**

**PVC DWV**

**P103X**

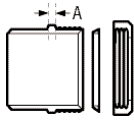
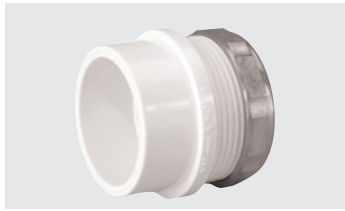

| CONNECTION<br><b>SP X SJ</b> | CHARLOTTE STYLE<br>103X | NIBCO STYLE<br>4801-2-7-C | LASCO STYLE<br>D115 | Dimensions |   |   |   |   |   |
|------------------------------|-------------------------|---------------------------|---------------------|------------|---|---|---|---|---|
| Size                         | Part Number             | Ctn Qty                   | Approx Net Wt.      | A          | B | C | D | E | F |
| 1-1/2"                       | 06392                   | 50                        | .15                 | 3/16       |   |   |   |   |   |
| 1-1/2" x 1-1/4"              | 06378                   | 100                       | .15                 | 3/16       |   |   |   |   |   |

**ADAPTER • TRAP • FEMALE ONE PIECE POLY NUT**

**PVC DWV**

**P104P**

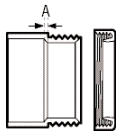

| CONNECTION<br><b>H x SJ</b> | CHARLOTTE STYLE<br>104P | NIBCO STYLE<br>N/A | LASCO STYLE<br>N/A | Dimensions |   |   |   |   |   |
|-----------------------------|-------------------------|--------------------|--------------------|------------|---|---|---|---|---|
| Size                        | Part Number             | Ctn Qty            | Approx Net Wt.     | A          | B | C | D | E | F |
| 1-1/4"                      | 06381                   | 50                 | .11                | 3/16       |   |   |   |   |   |
| 1-1/2"                      | 06377                   | 50                 | .12                | 3/16       |   |   |   |   |   |
| 1-1/2" x 1-1/4"             | 06395                   | 50                 | .09                | 3/16       |   |   |   |   |   |

**ADAPTER • TRAP • FEMALE PLASTIC NUT & WASHER**

**PVC DWV**

**P104W**

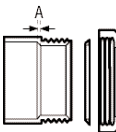

| CONNECTION<br><b>H x SJ</b> | CHARLOTTE STYLE<br>104W | NIBCO STYLE<br>4801-7 | LASCO STYLE<br>D104 | Dimensions |   |   |   |   |   |
|-----------------------------|-------------------------|-----------------------|---------------------|------------|---|---|---|---|---|
| Size                        | Part Number             | Ctn Qty               | Approx Net Wt.      | A          | B | C | D | E | F |
| 1-1/4"                      | 06380                   | 50                    | .13                 | 3/16       |   |   |   |   |   |
| 1-1/2"                      | 06383                   | 50                    | .13                 | 3/16       |   |   |   |   |   |
| 1-1/2" x 1-1/4"             | 06384                   | 50                    | .13                 | 3/16       |   |   |   |   |   |
| 2"                          | 06382                   | 25                    | .18                 | 3/16       |   |   |   |   |   |

**ADAPTER • TRAP • FEMALE W/CHROME NUT & WASHER**

**PVC DWV**

**P104X**

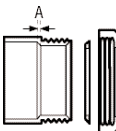

| CONNECTION<br><b>H x SJ</b> | CHARLOTTE STYLE<br>104X | NIBCO STYLE<br>4801-7-C | LASCO STYLE<br>D116 | Dimensions |   |   |   |   |   |
|-----------------------------|-------------------------|-------------------------|---------------------|------------|---|---|---|---|---|
| Size                        | Part Number             | Ctn Qty                 | Approx Net Wt.      | A          | B | C | D | E | F |
| 1-1/2"                      | 06376                   | 50                      | .17                 | 3/16       |   |   |   |   |   |
| 2"                          | 06397                   | 25                      | .24                 | 3/16       |   |   |   |   |   |
| 1-1/2" x 1-1/4"             | 06394                   | 50                      | .15                 | 3/16       |   |   |   |   |   |



## ADAPTER • CLEANOUT

PVC DWV

## P105

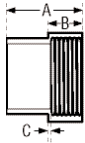
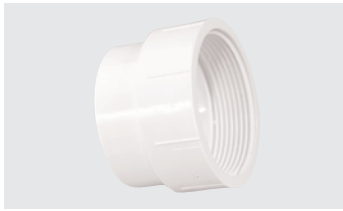

| CONNECTION<br>SP x FPT | CHARLOTTE STYLE<br>105 | NIBCO STYLE<br>4803-2 | LASCO STYLE<br>D105 | Dimensions |         |      |   |   |   |
|------------------------|------------------------|-----------------------|---------------------|------------|---------|------|---|---|---|
| Size                   | Part<br>Number         | Ctn<br>Qty            | Approx<br>Net Wt.   | A          | B       | C    | D | E | F |
| 1-1/4"                 | 05918                  | 50                    | .14                 | 1-19/32    | 27/32   | 5/32 |   |   |   |
| 1-1/2"                 | 05922                  | 50                    | .09                 | 1-5/8      | 7/8     | 5/32 |   |   |   |
| 2"                     | 05923                  | 50                    | .12                 | 1-17/32    | 29/32   | 5/32 |   |   |   |
| 3"                     | 05924                  | 25                    | .45                 | 2-29/32    | 1-13/64 | 3/16 |   |   |   |
| 4"                     | 05925                  | 10                    | .70                 | 3-13/32    | 1-5/16  | 1/4  |   |   |   |
| 6"                     | 06148                  | 10                    | 1.53                | 4-7/8      | 1-7/8   | 3/8  |   |   |   |

## ADAPTER • CLEANOUT • W/CLEANOUT PLUG

PVC DWV

## P105X

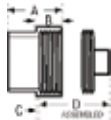

| CONNECTION<br>SP x FPT | CHARLOTTE STYLE<br>105X | NIBCO STYLE<br>4816 | LASCO STYLE<br>D112 | Dimensions |         |             |         |   |   |
|------------------------|-------------------------|---------------------|---------------------|------------|---------|-------------|---------|---|---|
| Size                   | Part<br>Number          | Ctn<br>Qty          | Approx<br>Net Wt.   | A          | B       | Approx<br>C | D       | E | F |
| 1-1/4"                 | 06007                   | 50                  | .15                 | 1-19/32    | 27/32   | 5/32        | 13/16   |   |   |
| 1-1/2"                 | 06001                   | 50                  | .15                 | 1-5/8      | 7/8     | 5/32        | 1-15/32 |   |   |
| 2"                     | 06002                   | 50                  | .21                 | 1-17/32    | 29/32   | 5/32        | 1-1/2   |   |   |
| 3"                     | 06003                   | 25                  | .56                 | 2-29/32    | 1-13/64 | 3/16        | 2-1/64  |   |   |
| 4"                     | 06004                   | 10                  | .92                 | 3-13/32    | 1-5/16  | 1/4         | 2-1/16  |   |   |
| 6"                     | 06005                   | 10                  | 2.53                | 4-7/8      | 1-7/8   | 3/8         | 2-1/2   |   |   |

## PLUG • CLEANOUT

PVC DWV

## P106



| CONNECTION<br>MPT | CHARLOTTE STYLE<br>106 | NIBCO STYLE<br>4818 | LASCO STYLE<br>D106 | Dimensions |       |   |   |   |   |
|-------------------|------------------------|---------------------|---------------------|------------|-------|---|---|---|---|
| Size              | Part<br>Number         | Ctn<br>Qty          | Approx<br>Net Wt.   | A          | B     | C | D | E | F |
| 1-1/4"            | 05937                  | 100                 | .07                 | 1/2        | 1     |   |   |   |   |
| 1-1/2"            | 05938                  | 50                  | .06                 | 5/8        | 1-3/8 |   |   |   |   |
| 2"                | 05939                  | 50                  | .09                 | 3/4        | 1-3/8 |   |   |   |   |
| 3"                | 05941                  | 25                  | .19                 | 3/4        | 1-3/4 |   |   |   |   |
| 4"                | 05942                  | 30                  | .34                 | 7/8        | 1-7/8 |   |   |   |   |
| 6"                | 06146                  | 10                  | .80                 | 1          | 2     |   |   |   |   |

## PLUG • SLIP

PVC DWV

## P106P

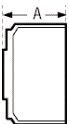

| CONNECTION<br>SP | CHARLOTTE STYLE<br>N/A | NIBCO STYLE<br>N/A | LASCO STYLE<br>N/A | Dimensions |   |   |   |   |   |
|------------------|------------------------|--------------------|--------------------|------------|---|---|---|---|---|
| Size             | Part<br>Number         | Ctn<br>Qty         | Approx<br>Net Wt.  | A          | B | C | D | E | F |
| 1-1/2"           | 06055                  | 25                 | .05                | 1-1/16     |   |   |   |   |   |
| 2"               | 06056                  | 50                 | .08                | 1-1/8      |   |   |   |   |   |

**BUSHING • FLUSH**

**PVC DWV**

**P107**



Style #3

| CONNECTION<br>SP x H | CHARLOTTE STYLE<br>107 | NIBCO STYLE<br>4801-2-F | LASCO STYLE<br>D107 | Dimensions |      |   |   |   |   |
|----------------------|------------------------|-------------------------|---------------------|------------|------|---|---|---|---|
| Size                 | Part<br>Number         | Ctn<br>Qty              | Approx<br>Net Wt.   | A          | B    | C | D | E | F |
| 1-1/2" x 1-1/4"      | 05904                  | 100                     | .05                 | 1          | 3/16 |   |   |   |   |
| 2" x 1-1/4"          | 05905                  | 50                      | .14                 | 1-1/16     | 5/16 |   |   |   |   |
| 2" x 1-1/2"          | 05906                  | 50                      | .11                 | 1-1/16     | 5/16 |   |   |   |   |
| 3" x 1-1/2"          | 05907                  | 30                      | .35                 | 1-1/2      | 3/4  |   |   |   |   |
| 3" x 2"              | 05908                  | 30                      | .34                 | 1-1/2      | 3/4  |   |   |   |   |
| 4" x 2"              | 05910                  | 30                      | .54                 | 2          | 1/4  |   |   |   |   |
| 4" x 3"              | 05909                  | 30                      | .53                 | 1-3/4      | 1/4  |   |   |   |   |

**BUSHING • FLANGE • W/TUBE STOP**

**PVC DWV**

**P107S**

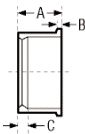

Style #1

| CONNECTION<br>SP x H | CHARLOTTE STYLE<br>N/A | NIBCO STYLE<br>N/A | LASCO STYLE<br>N/A | Dimensions |     |       |   |   |   |
|----------------------|------------------------|--------------------|--------------------|------------|-----|-------|---|---|---|
| Size                 | Part<br>Number         | Ctn<br>Qty         | Approx<br>Net Wt.  | A          | B   | C     | D | E | F |
| 6" x 4"              | 06144                  | 10                 | 1.92               | 3-1/2      | 1/2 | 1-3/4 |   |   |   |
| <b>EXTENDED</b>      |                        |                    |                    |            |     |       |   |   |   |
| 8" x 6"              | 06149                  | 4                  | 4.00               | 4-5/8      | 5/8 | 1-5/8 |   |   |   |

**BUSHING • FLUSH • (CLEANOUT ADAPTER)**

**PVC DWV**

**P108**

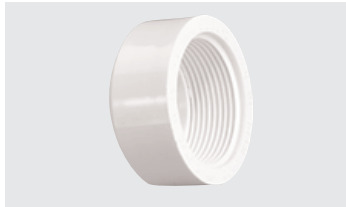

Style #3

| CONNECTION<br>SP x FPT | CHARLOTTE STYLE<br>108 | NIBCO STYLE<br>4803-2-F | LASCO STYLE<br>D108 | Dimensions |   |   |   |   |   |
|------------------------|------------------------|-------------------------|---------------------|------------|---|---|---|---|---|
| Size                   | Part<br>Number         | Ctn<br>Qty              | Approx<br>Net Wt.   | A          | B | C | D | E | F |
| 2" x 1-1/2"            | 05913                  | 50                      | .11                 | 1-1/16     |   |   |   |   |   |

TUBE & PIPE

METAL FITTINGS  
& NIPPLES

PLASTIC  
FITTINGS

VALVES

FILTER-DRYERS  
& STRAINERS



## ADAPTER • MALE

PVC DWV

## PI09

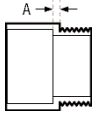

| CONNECTION<br>H x MPT | CHARLOTTE STYLE<br>109 | NIBCO STYLE<br>4804 | LASCO STYLE<br>D109 | Dimensions |   |   |   |   |   |
|-----------------------|------------------------|---------------------|---------------------|------------|---|---|---|---|---|
| Size                  | Part<br>Number         | Ctn<br>Qty          | Approx<br>Net Wt.   | A          | B | C | D | E | F |
| 1-1/4"                | 05931                  | 50                  | .08                 | 3/16       |   |   |   |   |   |
| 1-1/2"                | 05927                  | 50                  | .09                 | 3/16       |   |   |   |   |   |
| 2"                    | 05928                  | 50                  | .14                 | 3/16       |   |   |   |   |   |
| 3"                    | 05929                  | 25                  | .46                 | 3/8        |   |   |   |   |   |
| 4"                    | 05930                  | 25                  | .63                 | 3/8        |   |   |   |   |   |
| <b>REDUCING</b>       |                        |                     |                     |            |   |   |   |   |   |
| 1-1/2" x 1-1/4"       | 05926                  | 25                  | .10                 | 3/16       |   |   |   |   |   |

## PLUG • FLUSH CLEANOUT

PVC DWV

## PI10

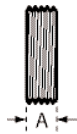

(W/SLOTS)

| CONNECTION<br>MPT | CHARLOTTE STYLE<br>110 | NIBCO STYLE<br>N/A | LASCO STYLE<br>D110 | Dimensions |   |   |   |   |   |
|-------------------|------------------------|--------------------|---------------------|------------|---|---|---|---|---|
| Size              | Part<br>Number         | Ctn<br>Qty         | Approx<br>Net Wt.   | A          | B | C | D | E | F |
| 4"                | 06015                  | 25                 | .38                 | 3/4        |   |   |   |   |   |

## ADAPTER • MALE

PVC DWV

## PI11

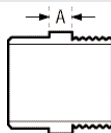

| CONNECTION<br>SP x MPT | CHARLOTTE STYLE<br>111 | NIBCO STYLE<br>4804-2 | LASCO STYLE<br>N/A | Dimensions |   |   |   |   |   |
|------------------------|------------------------|-----------------------|--------------------|------------|---|---|---|---|---|
| Size                   | Part<br>Number         | Ctn<br>Qty            | Approx<br>Net Wt.  | A          | B | C | D | E | F |
| 1-1/4"                 | 06010                  | 50                    | .08                | 5/32       |   |   |   |   |   |
| 1-1/2"                 | 06386                  | 50                    | .09                | 5/32       |   |   |   |   |   |
| 2"                     | 06385                  | 25                    | .17                | 5/32       |   |   |   |   |   |
| 3"                     | 06366                  | 25                    | .37                | 3/8        |   |   |   |   |   |
| <b>REDUCING</b>        |                        |                       |                    |            |   |   |   |   |   |
| 1-1/2" x 1-1/4"        | 06387                  | 100                   | .08                | 5/16       |   |   |   |   |   |

## ADAPTER • TRAY PLUG

PVC DWV

### PI13

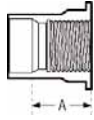
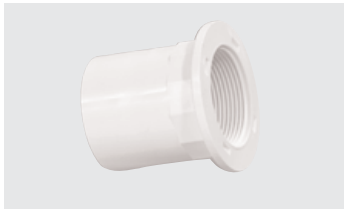

| CONNECTION<br><b>H x NPSM THREAD</b> | CHARLOTTE STYLE<br>N/A |            |                   | NIBCO STYLE<br>N/A |   | LASCO STYLE<br>N/A |  |  |  |
|--------------------------------------|------------------------|------------|-------------------|--------------------|---|--------------------|--|--|--|
|                                      | Part<br>Number         | Ctn<br>Qty | Approx<br>Net Wt. | Dimensions         |   |                    |  |  |  |
| Size                                 | A                      | B          | C                 | D                  | E | F                  |  |  |  |
| 1-1/2"                               | 06014                  | 50         | .34               | 1-7/8              |   |                    |  |  |  |

## ADAPTER • TRAY PLUG • SPIGOT

PVC DWV

### PI13S

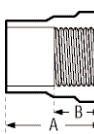
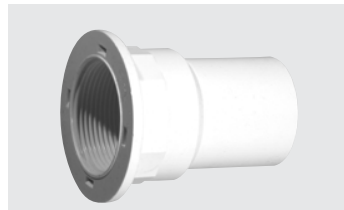

| CONNECTION<br><b>SP X NPSM THREAD</b> | CHARLOTTE STYLE<br>N/A |            |                   | NIBCO STYLE<br>N/A |   | LASCO STYLE<br>N/A |  |  |  |
|---------------------------------------|------------------------|------------|-------------------|--------------------|---|--------------------|--|--|--|
|                                       | Part<br>Number         | Ctn<br>Qty | Approx<br>Net Wt. | Dimensions         |   |                    |  |  |  |
| Size                                  | A                      | B          | C                 | D                  | E | F                  |  |  |  |
| 1-1/2"                                | 06419                  | 50         | .18               | 3-3/8              |   | 1-9/16             |  |  |  |

## CAP • THREADED

PVC DWV

### PI14

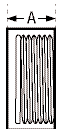

| CONNECTION<br><b>FPT</b> | CHARLOTTE STYLE<br>N/A |            |                   | NIBCO STYLE<br>N/A |   | LASCO STYLE<br>N/A |  |  |  |
|--------------------------|------------------------|------------|-------------------|--------------------|---|--------------------|--|--|--|
|                          | Part<br>Number         | Ctn<br>Qty | Approx<br>Net Wt. | Dimensions         |   |                    |  |  |  |
| Size                     | A                      | B          | C                 | D                  | E | F                  |  |  |  |
| 1-1/2"                   | 05993                  | 100        | .08               | 7/8                |   |                    |  |  |  |
| 2"                       | 05994                  | 50         | .12               | 7/8                |   |                    |  |  |  |

TUBE & PIPE

METAL FITTINGS  
& NIPPLES

PLASTIC  
FITTINGS

VALVES

FILTER-DRIVERS  
& STRAINERS



## CAP • SOCKET

PVC DWV

## PI16

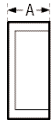
CONNECTION  
**H**CHARLOTTE STYLE  
116NIBCO STYLE  
4817LASCO STYLE  
447

| Size   | Part Number | Ctn Qty | Approx Net Wt. | Dimensions |   |   |   |   |   |
|--------|-------------|---------|----------------|------------|---|---|---|---|---|
|        |             |         |                | A          | B | C | D | E | F |
| 1-1/2" | 05977       | 50      | .09            | 1-1/16     |   |   |   |   |   |
| 2"     | 05978       | 25      | .13            | 1-3/16     |   |   |   |   |   |
| 3"     | 05979       | 25      | .38            | 2-1/4      |   |   |   |   |   |
| 4"     | 05980       | 5       | .69            | 2-5/16     |   |   |   |   |   |
| 6"     | 06057       | 5       | 2.25           | 3-3/4      |   |   |   |   |   |
| 8"     | 06058       | 3       | 3.90           | 4-7/8      |   |   |   |   |   |

## COUPLING • ADAPTER

PVC DWV

## PI17

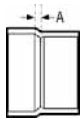
CONNECTION  
**S/D H x DWV H**CHARLOTTE STYLE  
117NIBCO STYLE  
4800-SDLASCO STYLE  
D117

| Size    | Part Number | Ctn Qty | Approx Net Wt. | Dimensions |   |   |   |   |   |
|---------|-------------|---------|----------------|------------|---|---|---|---|---|
|         |             |         |                | A          | B | C | D | E | F |
| 3"      | 05970       | 10      | .63            | 1/8        |   |   |   |   |   |
| 4"      | 05963       | 10      | .60            | 1/4        |   |   |   |   |   |
| 4" x 3" | 05962       | 20      | .55            | 1/4        |   |   |   |   |   |

(ADAPTS SEWER &amp; DRAIN PIPE TO DWV PIPE)

## COUPLING • ADAPTER

PVC DWV

## PI17X

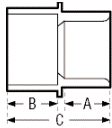
CONNECTION  
**S/D SP x DWV H**CHARLOTTE STYLE  
N/ANIBCO STYLE  
N/ALASCO STYLE  
N/A

| Size    | Part Number | Ctn Qty | Approx Net Wt. | Dimensions |       |       |   |   |   |
|---------|-------------|---------|----------------|------------|-------|-------|---|---|---|
|         |             |         |                | A          | B     | C     | D | E | F |
| 4" x 3" | 05992       | 10      | .48            | 3/16       | 1-3/4 | 3-1/2 |   |   |   |

(ADAPTS 4" S/D HUB TO 3" DWV PIPE)

## BUSHING • ADAPTER (DWV SPIGOT X S/D HUB)

PVC DWV

## PI18

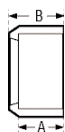
CONNECTION  
**DWV SP x SD H**CHARLOTTE STYLE  
118NIBCO STYLE  
N/ALASCO STYLE  
D118

| Size | Part Number | Ctn Qty | Approx Net Wt. | Dimensions |       |   |   |   |   |
|------|-------------|---------|----------------|------------|-------|---|---|---|---|
|      |             |         |                | A          | B     | C | D | E | F |
| 3"   | 05990       | 25      | .12            | 1-1/2      | 1-3/4 |   |   |   |   |
| 4"   | 05991       | 10      | .20            | 1-3/4      | 2     |   |   |   |   |

(ADAPTS DWV HUB TO S/D PIPE)

**ADAPTER • NO HUB**

**PVC DWV**

**PI19**



(ADAPTS CI NO HUB TO DWV PIPE)

| CONNECTION<br>CI NO H X DWV H |             | CHARLOTTE STYLE<br>119 |                | NIBCO STYLE<br>N/A |       | Dimensions |         |   |   |  |  |
|-------------------------------|-------------|------------------------|----------------|--------------------|-------|------------|---------|---|---|--|--|
| Size                          | Part Number | Ctn Qty                | Approx Net Wt. | A                  | B     | C          | D       | E | F |  |  |
| 2"                            | 05954       | 25                     | .16            | 2-3/8              | 1-1/8 | 1-5/8      | 2-1/2   |   |   |  |  |
| 3"                            | 05955       | 20                     | .40            | 3-3/8              | 1-1/8 | 1-7/8      | 3-3/8   |   |   |  |  |
| 4"                            | 05956       | 15                     | .63            | 4-7/16             | 1-1/8 | 1-15/16    | 3-11/16 |   |   |  |  |
| <b>REDUCING</b>               |             |                        |                |                    |       |            |         |   |   |  |  |
| 4" x 3"                       | 05953       | 10                     | .44            | 4-7/16             | 1-1/8 | 1-15/16    | 3-7/16  |   |   |  |  |

**ADAPTER • SCHEDULE 40 TO SCHEDULE 30**

**PVC DWV**

**PI20**

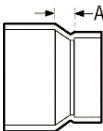

(ADAPTS 3" SCH. 40 TO 3" SCH. 30)

| CONNECTION<br>H x H |             | CHARLOTTE STYLE<br>N/A |                | NIBCO STYLE<br>N/A |   | Dimensions |   |   |   |  |  |
|---------------------|-------------|------------------------|----------------|--------------------|---|------------|---|---|---|--|--|
| Size                | Part Number | Ctn Qty                | Approx Net Wt. | A                  | B | C          | D | E | F |  |  |
| 3"                  | 05996       | 20                     | .15            | 1/8                |   |            |   |   |   |  |  |

**ADAPTER • SPIGOT • CAST IRON**

**PVC DWV**

**PI22**

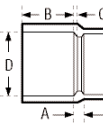

(ADAPTS CI SPIGOT TO DWV PIPE)

| CONNECTION<br>CI H x DWV H |             | CHARLOTTE STYLE<br>122 |                | NIBCO STYLE<br>4800 |       | Dimensions |        |   |   |  |  |
|----------------------------|-------------|------------------------|----------------|---------------------|-------|------------|--------|---|---|--|--|
| Size                       | Part Number | Ctn Qty                | Approx Net Wt. | A                   | B     | C          | D      | E | F |  |  |
| 2"                         | 05944       | 50                     | .31            | 5/16                | 2-3/8 | 1/8        | 2-5/16 |   |   |  |  |
| 4"                         | 05946       | 10                     | 1.13           | 5/16                | 2-7/8 | 1/8        | 4-5/16 |   |   |  |  |

**ADAPTER • HUB • CAST IRON**

**PVC DWV**

**PI23**

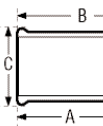
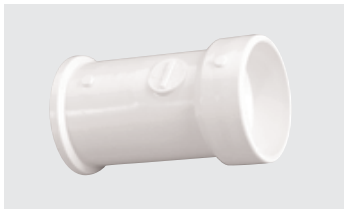

(ADAPTS CI HUB TO DWV PIPE)

| CONNECTION<br>CI SP x DWV H |             | CHARLOTTE STYLE<br>123 |                | NIBCO STYLE<br>4805 |       | Dimensions |   |   |   |  |  |
|-----------------------------|-------------|------------------------|----------------|---------------------|-------|------------|---|---|---|--|--|
| Size                        | Part Number | Ctn Qty                | Approx Net Wt. | A                   | B     | C          | D | E | F |  |  |
| 2"                          | 05957       | 20                     | .31            | 3-1/2               | 4-3/4 | 2-3/4      |   |   |   |  |  |
| 3"                          | 05958       | 20                     | .74            | 4-1/4               | 5-7/8 | 3-3/4      |   |   |   |  |  |
| 4"                          | 05959       | 20                     | 1.17           | 4-7/8               | 6-5/8 | 4-3/4      |   |   |   |  |  |

TUBE & PIPE

METAL FITTINGS & NIPPLES

PLASTIC FITTINGS

VALVES

FILTER-DRIVERS & STRAINERS



## ADAPTER • HUB • CAST IRON • INCREASER

PVC DWV

## PI23R

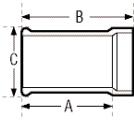
CONNECTION  
CI SP x DWV HCHARLOTTE STYLE  
123-RNIBCO STYLE  
4805LASCO STYLE  
D123

| Size        | Part Number | Ctn Qty | Approx Net Wt. | Dimensions |        |       |   |   |   |
|-------------|-------------|---------|----------------|------------|--------|-------|---|---|---|
|             |             |         |                | A          | B      | C     | D | E | F |
| 2" x 1-1/2" | 05961       | 10      | .28            | 3-9/16     | 4-7/8  | 3-5/8 |   |   |   |
| 3" x 1-1/2" | 05964       | 10      | .45            | 4          | 5-1/16 | 3-7/8 |   |   |   |
| 3" x 2"     | 06398       | 20      | .52            | 3-3/8      | 4-1/8  | 2-5/8 |   |   |   |
| 4" x 3"     | 05960       | 10      | 1.04           | 4          | 5-3/4  | 4-3/4 |   |   |   |

(ADAPTS CI HUB TO DWV PIPE)

## COUPLING • REPAIR

PVC DWV

## PI30

CONNECTION  
H x HCHARLOTTE STYLE  
130NIBCO STYLE  
4801-RPLASCO STYLE  
D130

| Part Size | Ctn Number | Approx Qty | Net Wt. | Dimensions |   |   |   |   |   |
|-----------|------------|------------|---------|------------|---|---|---|---|---|
|           |            |            |         | A          | B | C | D | E | F |
| 1-1/2"    | 05965      | 20         | .09     | 1-1/2      |   |   |   |   |   |
| 2"        | 05966      | 25         | .12     | 1-3/4      |   |   |   |   |   |
| 3"        | 05967      | 10         | .44     | 3          |   |   |   |   |   |
| 4"        | 05968      | 5          | .77     | 3-1/2      |   |   |   |   |   |

## NUT • SLIP JOINT • PLASTIC

PVC DWV

## PI40

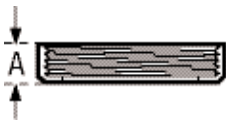
CONNECTION  
NPSM THREADCHARLOTTE STYLE  
N/ANIBCO STYLE  
N/ALASCO STYLE  
N/A

| Size   | Part Number | Ctn Qty | Approx Net Wt. | Dimensions |   |   |   |   |   |
|--------|-------------|---------|----------------|------------|---|---|---|---|---|
|        |             |         |                | A          | B | C | D | E | F |
| 1-1/4" | 05743       | 400     | .04            | 1 1/16     |   |   |   |   |   |
| 1-1/2" | 05744       | 100     | .04            | 1 1/16     |   |   |   |   |   |
| 2"     | 05741       | 100     |                | 1 1/16     |   |   |   |   |   |

## NUT • I PIECE POLY

PVC DWV

## PI42

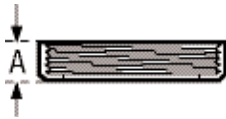
CONNECTION  
SJ x NPSM THREADCHARLOTTE STYLE  
N/ANIBCO STYLE  
N/ALASCO STYLE  
N/A

| Size   | Part Number | Ctn Qty | Approx Net Wt. | Dimensions |   |   |   |   |   |
|--------|-------------|---------|----------------|------------|---|---|---|---|---|
|        |             |         |                | A          | B | C | D | E | F |
| 1-1/4" | 01036       | 150     | .023           | 5/8        |   |   |   |   |   |
| 1-1/2" | 01038       | 125     | .025           | 5/8        |   |   |   |   |   |

**ELBOW • 1/4 BEND**

**PVC DWV**

**P300**

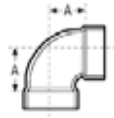

| CONNECTION<br><b>H x H</b> | CHARLOTTE STYLE<br>300 | NIBCO STYLE<br>4807 | LASCO STYLE<br>D300 | Dimensions |   |   |   |   |   |
|----------------------------|------------------------|---------------------|---------------------|------------|---|---|---|---|---|
| Size                       | Part Number            | Ctn Qty             | Approx Net Wt.      | A          | B | C | D | E | F |
| 1-1/4"                     | 05875                  | 50                  | .17                 | 1-9/16     |   |   |   |   |   |
| 1-1/2"                     | 05876                  | 100                 | .22                 | 1-3/4      |   |   |   |   |   |
| 2"                         | 05877                  | 50                  | .34                 | 2-5/16     |   |   |   |   |   |
| 3"                         | 05878                  | 25                  | 1.04                | 3-1/16     |   |   |   |   |   |
| 4"                         | 05879                  | 10                  | 1.85                | 3-7/8      |   |   |   |   |   |
| 6"                         | 06130                  | 5                   | 4.90                | 5          |   |   |   |   |   |
| 8"                         | 06131                  | 2                   | 4.83                | 6-1/8      |   |   |   |   |   |

**ELBOW • 1/4 BEND • REDUCING**

**PVC DWV**

**P300R**

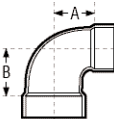

| CONNECTION<br><b>H x H</b> | CHARLOTTE STYLE<br>300-R | NIBCO STYLE<br>4807 | LASCO STYLE<br>D300 | Dimensions |        |   |   |   |   |
|----------------------------|--------------------------|---------------------|---------------------|------------|--------|---|---|---|---|
| Size                       | Part Number              | Ctn Qty             | Approx Net Wt.      | A          | B      | C | D | E | F |
| 2" x 1-1/2"                | 06092                    | 10                  | .31                 | 2-5/16     | 2-7/16 |   |   |   |   |

**ELBOW • 1/4 BEND • W/SIDE INLET**

**PVC DWV**

**P300S**

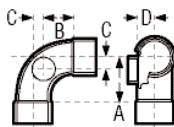
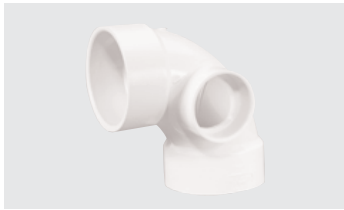

| CONNECTION<br><b>ALL HUB</b> | CHARLOTTE STYLE<br>300-S | NIBCO STYLE<br>4807-9 | LASCO STYLE<br>D301 | Dimensions |        |   |       |   |   |
|------------------------------|--------------------------|-----------------------|---------------------|------------|--------|---|-------|---|---|
| Size                         | Part Number              | Ctn Qty               | Approx Net Wt.      | A          | B      | C | D     | E | F |
| 3" x 3" x 1-1/2"             | 06069                    | 10                    | 1.05                | 3-1/16     | 2-1/16 | 1 | 1-7/8 |   |   |
| 3" x 3" x 2"                 | 06070                    | 10                    | 1.10                | 3-1/16     | 2-1/16 | 1 | 1-7/8 |   |   |

**ELBOW • 1/4 BEND • STREET**

**PVC DWV**

**P302**

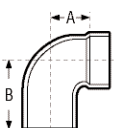

| CONNECTION<br><b>SP x H</b> | CHARLOTTE STYLE<br>302 | NIBCO STYLE<br>4807-2 | LASCO STYLE<br>D302 | Dimensions |        |   |   |   |   |
|-----------------------------|------------------------|-----------------------|---------------------|------------|--------|---|---|---|---|
| Size                        | Part Number            | Ctn Qty               | Approx Net Wt.      | A          | B      | C | D | E | F |
| 1-1/4"                      | 05894                  | 50                    | .17                 | 1-9/16     | 2-1/4  |   |   |   |   |
| 1-1/2"                      | 05880                  | 100                   | .20                 | 1-3/4      | 2-7/16 |   |   |   |   |
| 2"                          | 05881                  | 50                    | .34                 | 2-5/16     | 3-1/16 |   |   |   |   |
| 3"                          | 05882                  | 20                    | .95                 | 3-1/16     | 4-9/16 |   |   |   |   |
| 4"                          | 05883                  | 10                    | 1.75                | 3-7/8      | 5-5/8  |   |   |   |   |
| 6"                          | 05889                  | 5                     | 4.65                | 5          | 8      |   |   |   |   |



## ELBOW • 1/4 BEND • W/LOW HEEL INLET

PVC DWV

## P303



| CONNECTION<br><b>ALL HUB</b> | CHARLOTTE STYLE<br>303 | NIBCO STYLE<br>4861-LH | LASCO STYLE<br>D303 | Dimensions |        |   |   |   |   |
|------------------------------|------------------------|------------------------|---------------------|------------|--------|---|---|---|---|
| Size                         | Part<br>Number         | Ctn<br>Qty             | Approx<br>Net Wt.   | A          | B      | C | D | E | F |
| 3" x 3" x 1-1/2"             | 06041                  | 25                     | 1.07                | 3-1/16     | 4-1/2  |   |   |   |   |
| 3" x 3" x 2"                 | 06042                  | 25                     | 1.13                | 3-1/16     | 4-7/16 |   |   |   |   |
| 4" x 4" x 2"                 | 06043                  | 15                     | 1.56                | 3-7/8      | 5-7/16 |   |   |   |   |

## ELBOW • LONG SWEEP • 1/4 BEND

PVC DWV

## P304

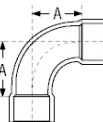

| CONNECTION<br><b>H x H</b> | CHARLOTTE STYLE<br>304 | NIBCO STYLE<br>4807-LT | LASCO STYLE<br>D304 | Dimensions |   |   |   |   |   |
|----------------------------|------------------------|------------------------|---------------------|------------|---|---|---|---|---|
| Part<br>Size               | Ctn<br>Number          | Approx<br>Qty          | Net Wt.             | A          | B | C | D | E | F |
| 1-1/2"                     | 05871                  | 50                     | .28                 | 2-3/4      |   |   |   |   |   |
| 2"                         | 05872                  | 25                     | .45                 | 3-1/4      |   |   |   |   |   |
| 3"                         | 05873                  | 10                     | 1.27                | 4-1/16     |   |   |   |   |   |
| 4"                         | 05874                  | 5                      | 2.23                | 4-15/16    |   |   |   |   |   |

## ELBOW • LONG SWEEP • 1/4 BEND W/HIGH HEEL INLET

PVC DWV

## P305

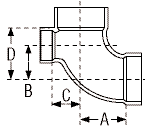

| CONNECTION<br><b>ALL HUB</b> | CHARLOTTE STYLE<br>305 | NIBCO STYLE<br>4861 | LASCO STYLE<br>N/A | Dimensions |       |        |        |   |   |
|------------------------------|------------------------|---------------------|--------------------|------------|-------|--------|--------|---|---|
| Size                         | Part<br>Number         | Ctn<br>Qty          | Approx<br>Net Wt.  | A          | B     | C      | D      | E | F |
| 3" x 3" x 1-1/2"             | 06028                  | 10                  | 1.29               | 4-1/16     | 2-1/4 | 1-9/16 | 3-5/8  |   |   |
| 3" x 3" x 2"                 | 06027                  | 25                  | 1.29               | 4-1/16     | 2-1/4 | 1-9/16 | 4-1/16 |   |   |

## ELBOW • LONG SWEEP • 1/4 BEND W/LOW HEEL INLET

PVC DWV

## P307

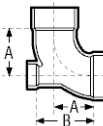

| CONNECTION<br><b>ALL HUB</b> | CHARLOTTE STYLE<br>307 | NIBCO STYLE<br>N/A | LASCO STYLE<br>D307 | Dimensions |         |   |   |   |
|------------------------------|------------------------|--------------------|---------------------|------------|---------|---|---|---|
| Size                         | Part<br>Number         | Ctn<br>Qty         | Approx<br>Net Wt.   | A          | B       | C | D | E |
| 3" x 3" x 1-1/2"             | 06025                  | 10                 | 1.30                | 4-1/16     | 4-3/4   |   |   |   |
| 3" x 3" x 2"                 | 06024                  | 25                 | 1.31                | 4-1/16     | 4-15/16 |   |   |   |

**ELBOW • 1/6 BEND • STREET**

**PVC DWV**

**P320**

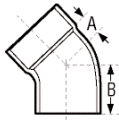

| CONNECTION<br>SP x H | CHARLOTTE STYLE<br>320 | NIBCO STYLE<br>4860-2 | LASCO STYLE<br>N/A |            |        |   |   |   |   |
|----------------------|------------------------|-----------------------|--------------------|------------|--------|---|---|---|---|
| Size                 | Part Number            | Ctn Qty               | Approx Net Wt.     | Dimensions |        |   |   |   |   |
|                      |                        |                       |                    | A          | B      | C | D | E | F |
| 1-1/2"               | 06020                  | 50                    | .17                | 1          | 11/16  |   |   |   |   |
| 2"                   | 06021                  | 20                    | .27                | 1-7/16     | 2-1/16 |   |   |   |   |
| 3"                   | 06022                  | 20                    | .80                | 1-11/16    | 3-3/16 |   |   |   |   |
| 4"                   | 06023                  | 5                     | 1.54               | 2-1/16     | 3-9/16 |   |   |   |   |

**ELBOW • 1/8 BEND**

**PVC DWV**

**P321**

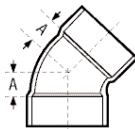

| CONNECTION<br>H x H | CHARLOTTE STYLE<br>321 | NIBCO STYLE<br>4806 | LASCO STYLE<br>D321 |            |   |   |   |   |   |
|---------------------|------------------------|---------------------|---------------------|------------|---|---|---|---|---|
| Size                | Part Number            | Ctn Qty             | Approx Net Wt.      | Dimensions |   |   |   |   |   |
|                     |                        |                     |                     | A          | B | C | D | E | F |
| 1-1/4"              | 05884                  | 50                  | .14                 | 1          |   |   |   |   |   |
| 1-1/2"              | 05885                  | 100                 | .18                 | 1-1/8      |   |   |   |   |   |
| 2"                  | 05886                  | 50                  | .30                 | 1-1/2      |   |   |   |   |   |
| 3"                  | 05887                  | 20                  | .82                 | 1-3/4      |   |   |   |   |   |
| 4"                  | 05888                  | 10                  | 1.50                | 2-3/16     |   |   |   |   |   |
| 6"                  | 06132                  | 3                   | 4.11                | 3-3/8      |   |   |   |   |   |
| 8"                  | 06134                  | 3                   | 6.13                | 3-3/4      |   |   |   |   |   |

**ELBOW • 1/8 BEND • STREET**

**PVC DWV**

**P323**

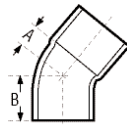

| CONNECTION<br>SP x H | CHARLOTTE STYLE<br>323 | NIBCO STYLE<br>4806-2 | LASCO STYLE<br>D323 |            |         |   |   |   |   |
|----------------------|------------------------|-----------------------|---------------------|------------|---------|---|---|---|---|
| Size                 | Part Number            | Ctn Qty               | Approx Net Wt.      | Dimensions |         |   |   |   |   |
|                      |                        |                       |                     | A          | B       | C | D | E | F |
| 1-1/4"               | 06016                  | 50                    | .14                 | 1          | 1-11/16 |   |   |   |   |
| 1-1/2"               | 05890                  | 100                   | .17                 | 1-1/8      | 1-13/16 |   |   |   |   |
| 2"                   | 05891                  | 50                    | .28                 | 1-1/2      | 2-1/4   |   |   |   |   |
| 3"                   | 05892                  | 20                    | .76                 | 1-3/4      | 3-1/4   |   |   |   |   |
| 4"                   | 05893                  | 10                    | 1.37                | 2-3/16     | 3-15/16 |   |   |   |   |
| 6"                   | 06133                  | 3                     | 3.95                | 3-3/8      | 6-3/8   |   |   |   |   |
| 8"                   | 06136                  | 3                     | 8.40                | 3-5/8      | 8-1/8   |   |   |   |   |

**ELBOW • 1/16 BEND**

**PVC DWV**

**P324**

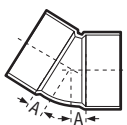

| CONNECTION<br>H x H | CHARLOTTE STYLE<br>324 | NIBCO STYLE<br>4808 | LASCO STYLE<br>D324 |            |   |   |   |   |   |
|---------------------|------------------------|---------------------|---------------------|------------|---|---|---|---|---|
| Size                | Part Number            | Ctn Qty             | Approx Net Wt.      | Dimensions |   |   |   |   |   |
|                     |                        |                     |                     | A          | B | C | D | E | F |
| 1-1/2"              | 05899                  | 50                  | .14                 | 1/2        |   |   |   |   |   |
| 2"                  | 05900                  | 25                  | .22                 | 11/16      |   |   |   |   |   |
| 3"                  | 05901                  | 20                  | .66                 | 13/16      |   |   |   |   |   |
| 4"                  | 05983                  | 15                  | 1.17                | 15/16      |   |   |   |   |   |
| 6"                  | 05988                  | 3                   | 3.01                | 1-7/16     |   |   |   |   |   |



TUBE & PIPE

METAL FITTINGS & NIPPLES

PLASTIC FITTINGS

VALVES

FILTER-DRIERS & STRAINERS

## ELBOW • 1/16 BEND • STREET

PVC DWV

## P326

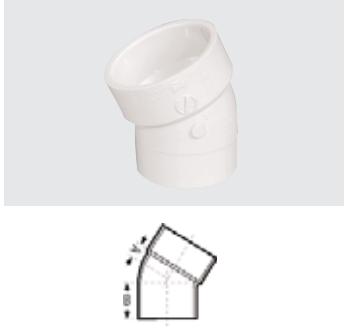

| CONNECTION<br>SP x H | CHARLOTTE STYLE<br>326 | NIBCO STYLE<br>4808-2 | LASCO STYLE<br>D326 | Dimensions |        |   |   |   |   |
|----------------------|------------------------|-----------------------|---------------------|------------|--------|---|---|---|---|
| Size                 | Part<br>Number         | Ctn<br>Qty            | Approx<br>Net Wt.   | A          | B      | C | D | E | F |
| 1-1/2"               | 05984                  | 50                    | .12                 | 1/2        | 1-3/16 |   |   |   |   |
| 2"                   | 05985                  | 25                    | .21                 | 11/16      | 1-7/16 |   |   |   |   |
| 3"                   | 05986                  | 20                    | .61                 | 13/16      | 2-5/16 |   |   |   |   |
| 4"                   | 05987                  | 10                    | 1.03                | 1          | 2-3/4  |   |   |   |   |

## ELBOW • DOUBLE • 1/4 BEND

PVC DWV

## P327

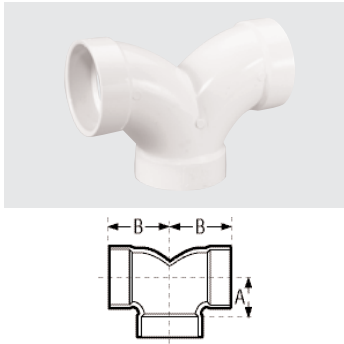

| CONNECTION<br>ALL HUB | CHARLOTTE STYLE<br>327 | NIBCO STYLE<br>4837 | LASCO STYLE<br>D327 | Dimensions |        |   |   |   |   |
|-----------------------|------------------------|---------------------|---------------------|------------|--------|---|---|---|---|
| Size                  | Part<br>Number         | Ctn<br>Qty          | Approx<br>Net Wt.   | A          | B      | C | D | E | F |
| 1-1/2"                | 06045                  | 20                  | .32                 | 1-3/4      | 1-3/4  |   |   |   |   |
| 2"                    | 06046                  | 25                  | .41                 | 2-5/16     | 2-5/16 |   |   |   |   |
| 3"                    | 06047                  | 10                  | 1.52                | 3-1/16     | 3-1/16 |   |   |   |   |
| 4"                    | 06048                  | 5                   | 2.65                | 3-7/8      | 3-7/8  |   |   |   |   |
| REDUCING              |                        |                     |                     |            |        |   |   |   |   |
| 2" x 1-1/2" x 1-1/2"  | 06049                  | 25                  | .32                 | 1-15/16    | 1-3/4  |   |   |   |   |

## ELBOW • CLOSET BEND • REDUCING

PVC DWV

## P329

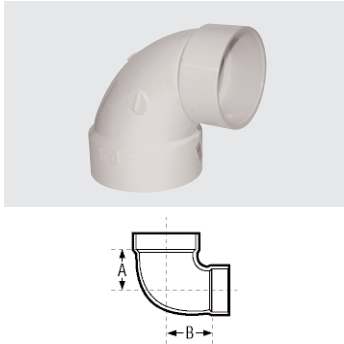

| CONNECTION<br>H x H | CHARLOTTE STYLE<br>329 | NIBCO STYLE<br>4807-CL | LASCO STYLE<br>D329 | Dimensions |       |   |   |   |   |
|---------------------|------------------------|------------------------|---------------------|------------|-------|---|---|---|---|
| Size                | Part<br>Number         | Ctn<br>Qty             | Approx<br>Net Wt.   | A          | B     | C | D | E | F |
| 4" x 3"             | 06093                  | 10                     | 1.35                | 3          | 3-3/8 |   |   |   |   |

## ELBOW • CLOSET BEND • REDUCING • STREET

PVC DWV

## P330

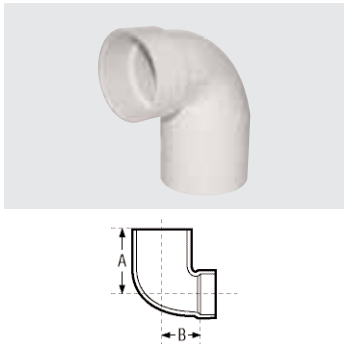

| CONNECTION<br>H x H | CHARLOTTE STYLE<br>330 | NIBCO STYLE<br>4807-2-CL | LASCO STYLE<br>D330 | Dimensions |       |   |   |   |   |
|---------------------|------------------------|--------------------------|---------------------|------------|-------|---|---|---|---|
| Size                | Part<br>Number         | Ctn<br>Qty               | Approx<br>Net Wt.   | A          | B     | C | D | E | F |
| 4" x 3"             | 06107                  | 10                       | 1.49                | 6          | 3-3/8 |   |   |   |   |

**ELBOW • CLOSET BEND • REDUCING • STREET W/TEST CAP**

**PVC DWV**

**P330X**

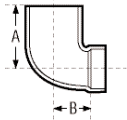

| CONNECTION<br><b>SP x H</b> | CHARLOTTE STYLE<br>330X | NIBCO STYLE<br>N/A | LASCO STYLE<br>N/A | Dimensions |       |   |   |   |   |
|-----------------------------|-------------------------|--------------------|--------------------|------------|-------|---|---|---|---|
| Size                        | Part Number             | Ctn Qty            | Approx Net Wt.     | A          | B     | C | D | E | F |
| 4" x 3"                     | 06108                   | 10                 | 1.60               | 6-1/16     | 3-3/8 |   |   |   |   |

**ELBOW • VENT ELL**

**PVC DWV**

**P331**

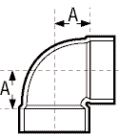

| CONNECTION<br><b>H x H</b> | CHARLOTTE STYLE<br>331 | NIBCO STYLE<br>4807-V | LASCO STYLE<br>D331 | Dimensions |          |   |   |   |   |
|----------------------------|------------------------|-----------------------|---------------------|------------|----------|---|---|---|---|
| Size                       | Number                 | Qty                   | Part Net Wt.        | Ctn A      | Approx B | C | D | E | F |
| 1-1/4"                     | 06083                  | 20                    | .16                 | 1          |          |   |   |   |   |
| 1-1/2"                     | 06084                  | 20                    | .20                 | 1-3/16     |          |   |   |   |   |
| 2"                         | 06085                  | 30                    | .29                 | 1-1/2      |          |   |   |   |   |
| 3"                         | 06086                  | 25                    | .84                 | 1-7/8      |          |   |   |   |   |

**ELBOW • VENT ELL • STREET**

**PVC DWV**

**P333**

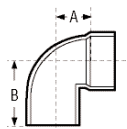

| CONNECTION<br><b>SP x H</b> | CHARLOTTE STYLE<br>333 | NIBCO STYLE<br>4807-2-V | LASCO STYLE<br>D333 | Dimensions |         |   |   |   |   |
|-----------------------------|------------------------|-------------------------|---------------------|------------|---------|---|---|---|---|
| Size                        | Part Number            | Ctn Qty                 | Approx Net Wt.      | A          | B       | C | D | E | F |
| 1-1/4"                      | 06091                  | 20                      | .15                 | 1          | 1-11/16 |   |   |   |   |
| 1-1/2"                      | 06088                  | 25                      | .18                 | 1-3/16     | 1-7/8   |   |   |   |   |
| 2"                          | 06089                  | 20                      | .27                 | 1-1/2      | 2-1/4   |   |   |   |   |
| 3"                          | 06090                  | 10                      | .81                 | 1-9/16     | 2-5/8   |   |   |   |   |

**TEE • SANITARY**

**PVC DWV**

**P400**

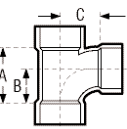

| CONNECTION<br><b>ALL HUB</b> | CHARLOTTE STYLE<br>400 | NIBCO STYLE<br>4811 | LASCO STYLE<br>D400 | Dimensions |        |        |   |   |   |
|------------------------------|------------------------|---------------------|---------------------|------------|--------|--------|---|---|---|
| Size                         | Part Number            | Ctn Qty             | Approx Net Wt.      | A          | B      | C      | D | E | F |
| 1-1/4"                       | 05751                  | 50                  | .24                 | 2-5/16     | 1-9/16 | 1-9/16 |   |   |   |
| 1-1/2"                       | 05752                  | 100                 | .30                 | 2-3/4      | 1-3/4  | 1-3/4  |   |   |   |
| 2"                           | 05753                  | 35                  | .50                 | 3-11/16    | 2-5/16 | 2-5/16 |   |   |   |
| 3"                           | 05754                  | 30                  | 1.39                | 4-7/8      | 3-1/16 | 3-1/16 |   |   |   |
| 4"                           | 05755                  | 5                   | 2.45                | 6-1/8      | 3-7/8  | 3-7/8  |   |   |   |
| 6"                           | 05756                  | 5                   | 6.10                | 8-1/2      | 5      | 5      |   |   |   |
| 8"                           | 05775                  | 1                   | 11.70               | 10-1/2     | 6      | 6      |   |   |   |



## TEE • SANITARY • REDUCING

PVC DWV

## P401

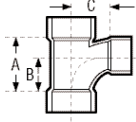

| CONNECTION               | CHARLOTTE STYLE | NIBCO STYLE | LASCO STYLE    |            |         |         |   |   |   |
|--------------------------|-----------------|-------------|----------------|------------|---------|---------|---|---|---|
| <b>ALL HUB</b>           | 401             | 4811        | D401           |            |         |         |   |   |   |
| Size                     | Part Number     | Ctn Qty     | Approx Net Wt. | Dimensions |         |         |   |   |   |
|                          |                 |             |                | A          | B       | C       | D | E | F |
| 1-1/2" x 1-1/2" x 1-1/4" | 05757           | 20          | .32            | 2-1/2      | 1-11/16 | 1-13/16 |   |   |   |
| 2" x 1-1/2" x 1-1/2"     | 05761           | 25          | .39            | 3-1/8      | 1-15/16 | 2-3/16  |   |   |   |
| 2" x 1-1/2" x 2"         | 05760           | 25          | .47            | 3-11/16    | 2-5/16  | 2-5/16  |   |   |   |
| 2" x 2" x 1-1/2"         | 05758           | 50          | .41            | 3-1/8      | 1-15/16 | 2-3/16  |   |   |   |
| 3" x 3" x 1-1/2"         | 05764           | 20          | .85            | 2-11/16    | 1-3/4   | 2-9/16  |   |   |   |
| 3" x 3" x 2"             | 05763           | 10          | .96            | 3-5/16     | 2-1/8   | 2-7/8   |   |   |   |
| 4" x 4" x 1-1/2"         | 05767           | 5           | 1.53           | 3-1/16     | 2       | 3-1/4   |   |   |   |
| 4" x 4" x 2"             | 05765           | 10          | 1.47           | 3-3/16     | 2-1/16  | 3-5/16  |   |   |   |
| 4" x 4" x 3"             | 05766           | 10          | 1.93           | 4-3/4      | 3       | 3-9/16  |   |   |   |
| 6" x 6" x 4"             | 05768           | 5           | 4.28           | 5-13/16    | 3-5/8   | 4-5/16  |   |   |   |

## TEE • SANITARY • STREET

PVC DWV

## P403

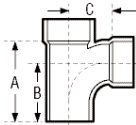

| CONNECTION        | CHARLOTTE STYLE | NIBCO STYLE | LASCO STYLE    |            |        |        |   |   |   |
|-------------------|-----------------|-------------|----------------|------------|--------|--------|---|---|---|
| <b>SP x H x H</b> | 403             | 4811-2      | D403           |            |        |        |   |   |   |
| Size              | Part Number     | Ctn Qty     | Approx Net Wt. | Dimensions |        |        |   |   |   |
|                   |                 |             |                | A          | B      | C      | D | E | F |
| 1-1/2"            | 06112           | 20          | .29            | 3-7/16     | 2-7/16 | 1-3/4  |   |   |   |
| 2"                | 06113           | 25          | .46            | 4-7/16     | 3-1/16 | 2-5/16 |   |   |   |
| 3"                | 06114           | 30          | 1.32           | 6-3/8      | 4-9/16 | 3-1/16 |   |   |   |
| 4"                | 06120           | 10          | 2.34           | 7-7/8      | 5-5/8  | 3-7/8  |   |   |   |

## TEE • SANITARY • STREET • REDUCING

PVC DWV

## P404

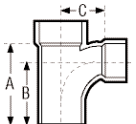

| CONNECTION           | CHARLOTTE STYLE | NIBCO STYLE | LASCO STYLE    |            |         |        |   |   |   |
|----------------------|-----------------|-------------|----------------|------------|---------|--------|---|---|---|
| <b>SP x H x H</b>    | 404             | 4811-2      | D404           |            |         |        |   |   |   |
| Size                 | Part Number     | Ctn Qty     | Approx Net Wt. | Dimensions |         |        |   |   |   |
|                      |                 |             |                | A          | B       | C      | D | E | F |
| 2" x 1-1/2" x 1-1/2" | 06115           | 25          | .38            | 3-7/8      | 2-11/16 | 2-3/16 |   |   |   |
| 2" x 1-1/2" x 2"     | 06116           | 25          | .46            | 4-7/16     | 3-1/16  | 2-5/16 |   |   |   |
| 2" x 2" x 1-1/2"     | 06117           | 50          | .39            | 3-7/8      | 2-11/16 | 2-3/16 |   |   |   |
| 3" x 3" x 1-1/2"     | 06118           | 10          | .79            | 4-3/16     | 3-1/4   | 2-9/16 |   |   |   |
| 3" x 3" x 2"         | 06119           | 20          | .88            | 4-13/16    | 3-5/8   | 2-7/8  |   |   |   |
| 4" x 4" x 2"         | 06121           | 5           | 2.41           | 4-15/16    | 3-13/16 | 3-5/16 |   |   |   |

**TEE • SANITARY • W/LEFT SIDE INLET**

**PVC DWV**

**P416**

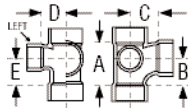

| CONNECTION            | CHARLOTTE STYLE | NIBCO STYLE | LASCO STYLE    |            |        |        |        |         |
|-----------------------|-----------------|-------------|----------------|------------|--------|--------|--------|---------|
| <b>ALL HUB</b>        | 416             | 4871        | D416           |            |        |        |        |         |
| Size                  | Part Number     | Ctn Qty     | Approx Net Wt. | Dimensions |        |        |        |         |
|                       |                 |             |                | A          | B      | C      | D      | E       |
| 3" x 3" x 3" x 1-1/2" | 05781           | 10          | 1.46           | 4-7/8      | 3-1/16 | 3-1/16 | 2-9/16 | 3-11/16 |
| 3" x 3" x 3" x 2"     | 05782           | 10          | 1.57           | 4-7/8      | 3-1/16 | 3-1/16 | 2-7/8  | 3-11/16 |
| 4" x 4" x 4" x 2"     | 05784           | 5           | 2.61           | 6-1/8      | 3-7/8  | 3-7/8  | 3-5/16 | 4-3/16  |

**TEE • SANITARY • W/RIGHT SIDE INLET**

**PVC DWV**

**P417**

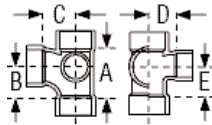

| CONNECTION            | CHARLOTTE STYLE | NIBCO STYLE | LASCO STYLE    |            |        |        |        |         |
|-----------------------|-----------------|-------------|----------------|------------|--------|--------|--------|---------|
| <b>ALL HUB</b>        | 417             | 4872        | D417           |            |        |        |        |         |
| Size                  | Part Number     | Ctn Qty     | Approx Net Wt. | Dimensions |        |        |        |         |
|                       |                 |             |                | A          | B      | C      | D      | E       |
| 3" x 3" x 3" x 1-1/2" | 05795           | 10          | 1.46           | 4-7/8      | 3-1/16 | 3-1/16 | 2-9/16 | 3-11/16 |
| 3" x 3" x 3" x 2"     | 05796           | 10          | 1.57           | 4-7/8      | 3-1/16 | 3-1/16 | 2-7/8  | 3-11/16 |
| 4" x 4" x 4" x 2"     | 05797           | 5           | 2.54           | 6-1/8      | 3-7/8  | 3-7/8  | 3-5/16 | 4-3/16  |

**TEE • SANITARY • DOUBLE • W/RIGHT & LEFT SIDE INLET**

**PVC DWV**

**P418**

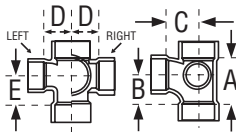

| CONNECTION                     | CHARLOTTE STYLE | NIBCO STYLE | LASCO STYLE    |            |        |        |        |         |
|--------------------------------|-----------------|-------------|----------------|------------|--------|--------|--------|---------|
| <b>ALL HUB</b>                 | 418             | 4870        | D418           |            |        |        |        |         |
| Size                           | Part Number     | Ctn Qty     | Approx Net Wt. | Dimensions |        |        |        |         |
|                                |                 |             |                | A          | B      | C      | D      | E       |
| 3" x 3" x 3" x 1-1/2" x 1-1/2" | 05810           | 10          | 1.61           | 4-7/8      | 3-1/16 | 3-1/16 | 2-9/16 | 3-11/16 |
| 3" x 3" x 3" x 2" x 2"         | 05811           | 5           | 1.76           | 4-7/8      | 3-1/16 | 3-1/16 | 2-7/8  | 3-11/16 |
| 4" x 4" x 4" x 1-1/2" x 1-1/2" | 05805           | 5           |                | 4-7/8      | 3-7/8  | 3-5/8  | 7-5/8  | 4-7/8   |
| 4" x 4" x 4" x 2" x 2"         | 05808           | 5           | 2.78           | 6-1/8      | 3-7/8  | 3-7/8  | 3-5/16 | 5       |

**TEE • SANITARY • DOUBLE**

**PVC DWV**

**P428**

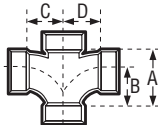

| CONNECTION     | CHARLOTTE STYLE | NIBCO STYLE | LASCO STYLE    |            |        |        |        |
|----------------|-----------------|-------------|----------------|------------|--------|--------|--------|
| <b>ALL HUB</b> | 428             | 4835        | D428           |            |        |        |        |
| Size           | Part Number     | Ctn Qty     | Approx Net Wt. | Dimensions |        |        |        |
|                |                 |             |                | A          | B      | C      | D      |
| 1-1/2"         | 05812           | 25          | .37            | 2-3/4      | 1-3/4  | 1-3/4  | 1-3/4  |
| 2"             | 05813           | 20          | .59            | 3-11/16    | 2-5/16 | 2-5/16 | 2-5/16 |
| 3"             | 05814           | 20          | 1.74           | 4-7/8      | 3-1/16 | 3-1/16 | 3-1/16 |
| 4"             | 05815           | 4           | 3.06           | 6-1/8      | 3-7/8  | 3-7/8  | 3-7/8  |



## TEE • SANITARY • DOUBLE • REDUCING

PVC DWV

P429

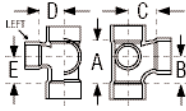

| CONNECTION<br><b>ALL HUB</b> | CHARLOTTE STYLE<br>429 | NIBCO STYLE<br>4835 | LASCO STYLE<br>D429 |            |         |        |        |   |
|------------------------------|------------------------|---------------------|---------------------|------------|---------|--------|--------|---|
| Size                         | Part<br>Number         | Ctn<br>Qty          | Approx<br>Net Wt.   | Dimensions |         |        |        |   |
|                              |                        |                     |                     | A          | B       | C      | D      | E |
| 2" x 2" x 1-1/2" x 1-1/2"    | 05817                  | 20                  | .50                 | 3-1/8      | 1-15/16 | 2-3/16 | 2-3/16 |   |
| 3" x 3" x 1-1/2" x 1-1/2"    | 05818                  | 20                  | .88                 | 2-11/16    | 1-3/4   | 2-9/16 | 2-9/16 |   |
| 3" x 3" x 2" x 2"            | 05820                  | 10                  | 1.04                | 3-5/16     | 2-1/8   | 2-7/8  | 2-7/8  |   |
| 4" x 4" x 2" x 2"            | 05240                  | 5                   | 1.49                | 3-3/16     | 2-1/16  | 3-5/16 | 3-5/16 |   |
| 4" x 4" x 3" x 3"            | 05821                  | 5                   | 2.20                | 4-3/4      | 3       | 3-9/16 | 3-9/16 |   |

## TEE • SANITARY • DOUBLE • STREET • REDUCING

PVC DWV

P431

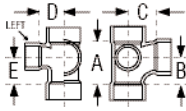

| CONNECTION<br><b>SP x H x H x H</b> | CHARLOTTE STYLE<br>431 | NIBCO STYLE<br>N/A | LASCO STYLE<br>D431 |            |       |       |   |   |
|-------------------------------------|------------------------|--------------------|---------------------|------------|-------|-------|---|---|
| Size                                | Part<br>Number         | Ctn<br>Qty         | Approx<br>Net Wt.   | Dimensions |       |       |   |   |
|                                     |                        |                    |                     | A          | B     | C     | D | E |
| 3" x 3" x 2" x 2"                   | 06310                  | 10                 | .98                 | 4-13/16    | 3-5/8 | 2-7/8 |   |   |

## TEE • SANITARY • DOUBLE • W/SIDE INLET

PVC DWV

P438

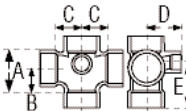

| CONNECTION<br><b>ALL HUB</b> | CHARLOTTE STYLE<br>438 | NIBCO STYLE<br>4835-9 | LASCO STYLE<br>D438 |            |        |        |       |        |
|------------------------------|------------------------|-----------------------|---------------------|------------|--------|--------|-------|--------|
| Size                         | Part<br>Number         | Ctn<br>Qty            | Approx<br>Net Wt.   | Dimensions |        |        |       |        |
|                              |                        |                       |                     | A          | B      | C      | D     | E      |
| 3" x 3" x 3" x 3" x 2"       | 05772                  | 10                    | 1.88                | 4-7/8      | 3-1/16 | 3-1/16 | 2-7/8 | 3-1/16 |

## TEE • SANITARY • DOUBLE • W/RIGHT &amp; LEFT SIDE INLET

PVC DWV

P439

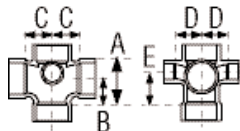

| CONNECTION<br><b>ALL HUB</b> | CHARLOTTE STYLE<br>439 | NIBCO STYLE<br>4835-9-9 | LASCO STYLE<br>D439 |            |        |        |       |         |
|------------------------------|------------------------|-------------------------|---------------------|------------|--------|--------|-------|---------|
| Size                         | Part<br>Number         | Ctn<br>Qty              | Approx<br>Net Wt.   | Dimensions |        |        |       |         |
|                              |                        |                         |                     | A          | B      | C      | D     | E       |
| 3" x 3" x 3" x 3" x 2" x 2"  | 05770                  | 10                      | 2.05                | 4-7/8      | 3-1/16 | 3-1/16 | 2-7/8 | 3-11/16 |

**TEE • VENT**

**PVC DWV**

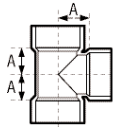

**P441**

| CONNECTION<br><b>ALL HUB</b> | CHARLOTTE STYLE<br>441 | NIBCO STYLE<br>4811-Y | LASCO STYLE<br>D441 |            |   |   |   |   |
|------------------------------|------------------------|-----------------------|---------------------|------------|---|---|---|---|
| Size                         | Part Number            | Ctn Qty               | Approx Net Wt.      | Dimensions |   |   |   |   |
|                              |                        |                       |                     | A          | B | C | D | E |
| 1-1/2"                       | 06403                  | 25                    | .26                 | 1-3/16     |   |   |   |   |
| 2"                           | 06404                  | 25                    | .40                 | 1-1/2      |   |   |   |   |
| 3"                           | 06405                  | 10                    | 1.09                | 1-7/8      |   |   |   |   |
| 4"                           | 06406                  | 5                     | 1.96                | 2-1/2      |   |   |   |   |

**TEE • CLEANOUT • W/C.O. PLUG**

**PVC DWV**

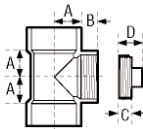

**P444X**

| CONNECTION<br><b>H x H x FPT</b> | CHARLOTTE STYLE<br>444-X | NIBCO STYLE<br>4814 | LASCO STYLE<br>D-443 |            |     |     |       |   |
|----------------------------------|--------------------------|---------------------|----------------------|------------|-----|-----|-------|---|
| Size                             | Part Number              | Ctn Qty             | Approx Net Wt.       | Dimensions |     |     |       |   |
|                                  |                          |                     |                      | A          | B   | C   | D     | E |
| 1-1/2"                           | 05997                    | 10                  | .34                  | 1-3/16     | 5/8 | 5/8 | 1-3/8 |   |
| 2"                               | 05998                    | 10                  | .49                  | 1-1/2      | 5/8 | 5/8 | 1-3/8 |   |
| 3"                               | 05999                    | 10                  | 1.24                 | 1-7/8      | 3/4 | 3/4 | 1-3/4 |   |
| 4"                               | 06000                    | 5                   | 2.30                 | 2-1/2      | 7/8 | 7/8 | 1-7/8 |   |

**TEE • FLUSH CLEANOUT**

**PVC DWV**

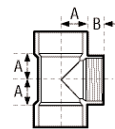

**P445**

| CONNECTION<br><b>H x H x FPT</b> | CHARLOTTE STYLE<br>445 | NIBCO STYLE<br>4811-14-V | LASCO STYLE<br>D445 |            |     |   |   |   |
|----------------------------------|------------------------|--------------------------|---------------------|------------|-----|---|---|---|
| Size                             | Part Number            | Ctn Qty                  | Approx Net Wt.      | Dimensions |     |   |   |   |
|                                  |                        |                          |                     | A          | B   | C | D | E |
| 1-1/2"                           | 06413                  | 20                       | .27                 | 1-3/16     | 5/8 |   |   |   |
| 2"                               | 06414                  | 20                       | .39                 | 1-1/2      | 5/8 |   |   |   |
| 3"                               | 06415                  | 10                       | 1.07                | 1-7/8      | 3/4 |   |   |   |
| 4"                               | 06416                  | 10                       | 1.96                | 2-1/2      | 7/8 |   |   |   |

**TEE • FLUSH CLEANOUT • W/FLUSH C.O. PLUG**

**PVC DWV**

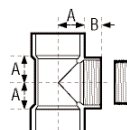

**P445X**

| CONNECTION<br><b>H x H x FPT</b> | CHARLOTTE STYLE<br>445X | NIBCO STYLE<br>N/A | LASCO STYLE<br>N/A |            |     |   |   |   |
|----------------------------------|-------------------------|--------------------|--------------------|------------|-----|---|---|---|
| Size                             | Part Number             | Ctn Qty            | Approx Net Wt.     | Dimensions |     |   |   |   |
|                                  |                         |                    |                    | A          | B   | C | D | E |
| 2"                               | 05198                   | 10                 | .39                | 1-1/2      | 5/8 |   |   |   |
| 3"                               | 05199                   | 10                 | 1.07               | 1-7/8      | 3/4 |   |   |   |
| 4"                               | 05200                   | 5                  | 1.96               | 2-1/2      | 7/8 |   |   |   |

TUBE & PIPE

METAL FITTINGS & NIPPLES

PLASTIC FITTINGS

VALVES

FILTER-DRYERS & STRAINERS



## TEE • HORIZONTAL TWIN

PVC DWV

P447

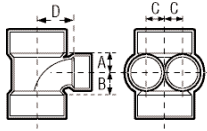

| CONNECTION<br>H x H x FPT | CHARLOTTE STYLE<br>447 | NIBCO STYLE<br>N/A | LASCO STYLE<br>N/A |            |       |        |        |   |
|---------------------------|------------------------|--------------------|--------------------|------------|-------|--------|--------|---|
| Size                      | Part<br>Number         | Ctn<br>Qty         | Approx<br>Net Wt.  | Dimensions |       |        |        |   |
|                           |                        |                    |                    | A          | B     | C      | D      | E |
| 3" x 3" x 1-1/2" x 1-1/2" | 05235                  | 5                  |                    | 7/8        | 1-3/4 | 1-3/32 | 2-9/16 |   |

## TEE • TWO-WAY • CLEANOUT

PVC DWV

P448

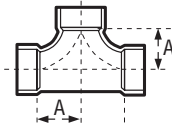

| CONNECTION<br>ALL HUB | CHARLOTTE STYLE<br>448 | NIBCO STYLE<br>4811-C | LASCO STYLE<br>D448 |            |   |   |   |   |
|-----------------------|------------------------|-----------------------|---------------------|------------|---|---|---|---|
| Size                  | Part<br>Number         | Ctn<br>Qty            | Approx<br>Net Wt.   | Dimensions |   |   |   |   |
|                       |                        |                       |                     | A          | B | C | D | E |
| 3"                    | 05237                  | 10                    | 1.97                | 4-1/16     |   |   |   |   |
| 4"                    | 05238                  | 5                     | 3.46                | 4-15/16    |   |   |   |   |

## WYE • DOUBLE FIXTURE

PVC DWV

P500

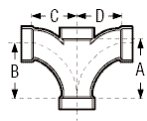

| CONNECTION<br>ALL HUB         | CHARLOTTE STYLE<br>500 | NIBCO STYLE<br>4835-B | LASCO STYLE<br>D510 |            |       |         |         |   |
|-------------------------------|------------------------|-----------------------|---------------------|------------|-------|---------|---------|---|
| Size                          | Part<br>Number         | Ctn<br>Qty            | Approx<br>Net Wt.   | Dimensions |       |         |         |   |
|                               |                        |                       |                     | A          | B     | C       | D       | E |
| 2"                            | 05246                  | 25                    | .83                 | 4-5/8      | 4-1/4 | 3-1/2   | 3-1/2   |   |
| 3"                            | 05249                  | 5                     | 2.63                | 6-3/4      | 6-1/4 | 4-15/16 | 4-15/16 |   |
| <b>REDUCING</b>               |                        |                       |                     |            |       |         |         |   |
| 2" x 1-1/2" x 1-1/2" x 1-1/2" | 05247                  | 20                    | .60                 | 3-1/2      | 3-1/8 | 2-7/8   | 2-7/8   |   |
| 2" x 2" x 1-1/2" x 1-1/2"     | 05244                  | 20                    | .64                 |            |       |         |         |   |
| 3" x 2" x 3" x 3"             | 05250                  | 5                     | 3.00                | 6-3/4      | 6-1/4 | 4-15/16 | 4-15/16 |   |

## WYE • COMBINATION • 1/8 BEND • ONE PIECE

PVC DWV

P501

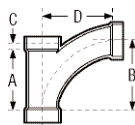

| CONNECTION<br>ALL HUB | CHARLOTTE STYLE<br>501 | NIBCO STYLE<br>4812-LR | LASCO STYLE<br>D501 |            |         |        |         |   |
|-----------------------|------------------------|------------------------|---------------------|------------|---------|--------|---------|---|
| Size                  | Part<br>Number         | Ctn<br>Qty             | Approx<br>Net Wt.   | Dimensions |         |        |         |   |
|                       |                        |                        |                     | A          | B       | C      | D       | E |
| 1-1/2"                | 05853                  | 50                     | .44                 | 3-1/2      | 3-15/16 | 7/16   | 3-15/16 |   |
| 2"                    | 05858                  | 20                     | .64                 | 4-7/16     | 5-1/8   | 1-1/16 | 5-1/8   |   |
| 3"                    | 05852                  | 10                     | 2.25                | 6-1/2      | 7-9/16  | 1-1/16 | 7-9/16  |   |
| 4"                    | 05860                  | 10                     | 4.21                | 8-1/2      | 10      | 1-1/2  | 10      |   |

**WYE • COMBINATION • 1/8 BEND • REDUCING • ONE PIECE**

**PVC DWV**

**P502**

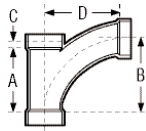

| CONNECTION<br><b>ALL HUB</b> | CHARLOTTE STYLE<br>502 | NIBCO STYLE<br>4812-LR | LASCO STYLE<br>D502 | Dimensions |         |        |         |   |
|------------------------------|------------------------|------------------------|---------------------|------------|---------|--------|---------|---|
| Size                         | Part Number            | Ctn Qty                | Approx Net Wt.      | A          | B       | C      | D       | E |
| 2" x 1-1/2" x 1-1/2"         | 05835                  | 5                      | .24                 | 3-1/2      | 3-15/16 | 7/16   | 4-3/16  |   |
| 2" x 1-1/2" x 2"             | 05836                  | 5                      | .73                 | 4-7/16     | 5-1/8   | 11/16  | 5-1/8   |   |
| 2" x 2" x 1-1/2"             | 05865                  | 20                     | .53                 | 3-1/2      | 3-15/16 | 7/16   | 4-3/16  |   |
| 3" x 3" x 1-1/2"             | 05837                  | 15                     | 1.04                | 3-1/2      | 3-15/16 | 7/16   | 4-3/4   |   |
| 3" x 3" x 2"                 | 05857                  | 10                     | 1.21                | 4-7/16     | 5-1/8   | 11/16  | 5-11/16 |   |
| 4" x 4" x 2"                 | 05863                  | 5                      | 1.86                | 4-1/2      | 5-1/8   | 5/8    | 6-1/8   |   |
| 4" x 4" x 3"                 | 05864                  | 5                      | 2.85                | 6-1/2      | 7-9/16  | 1-1/16 | 8-1/16  |   |

**WYE • COMBINATION • 1/8 BEND • TWO PIECE**

**PVC DWV**

**P503**

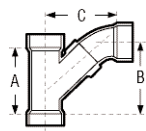

| CONNECTION<br><b>ALL HUB</b> | CHARLOTTE STYLE<br>503 | NIBCO STYLE<br>N/A | LASCO STYLE<br>D503 | Dimensions |        |        |   |   |
|------------------------------|------------------------|--------------------|---------------------|------------|--------|--------|---|---|
| Size                         | Part Number            | Ctn Qty            | Approx Net Wt.      | A          | B      | C      | D | E |
| 6"                           | 05266                  | 2                  | 11.32               | 10         | 12-1/2 | 13-7/8 |   |   |

**WYE • COMBINATION • 1/8 BEND • REDUCING • TWO PIECE**

**PVC DWV**

**P504**

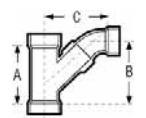

| CONNECTION<br><b>ALL HUB</b> | CHARLOTTE STYLE<br>504 | NIBCO STYLE<br>N/A | LASCO STYLE<br>D504 | Dimensions |       |    |   |   |
|------------------------------|------------------------|--------------------|---------------------|------------|-------|----|---|---|
| Size                         | Part Number            | Ctn Qty            | Approx Net Wt.      | A          | B     | C  | D | E |
| 6" x 6" x 4"                 | 05267                  | 4                  | 6.59                | 7          | 8-1/8 | 10 |   |   |

**WYE • COMBINATION • 1/8 BEND • DOUBLE • ASSEMBLY**

**PVC DWV**

**P507**

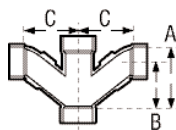
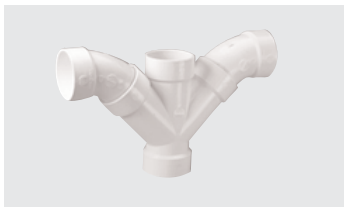

(THREE PIECE)

| CONNECTION<br><b>ALL HUB</b> | CHARLOTTE STYLE<br>507 | NIBCO STYLE<br>4836 | LASCO STYLE<br>D507 | Dimensions |       |       |   |   |
|------------------------------|------------------------|---------------------|---------------------|------------|-------|-------|---|---|
| Size                         | Part Number            | Ctn Qty             | Approx Net Wt.      | A          | B     | C     | D | E |
| 3"                           | 06032                  | 10                  | 3.86                | 6-1/2      | 7-3/8 | 7-3/8 |   |   |
| 4"                           | 06033                  | 4                   | 6.83                | 8          | 9-3/8 | 9-3/8 |   |   |

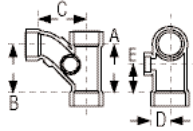

**WYE • COMBINATION • 1/8 BEND • W/LEFT SIDE INLET****PVC DWV****P515**

(TWO PIECE)

| CONNECTION        | CHARLOTTE STYLE | NIBCO STYLE | LASCO STYLE    |            |       |       |        |       |
|-------------------|-----------------|-------------|----------------|------------|-------|-------|--------|-------|
| <b>ALL HUB</b>    | 515             | N/A         | N/A            |            |       |       |        |       |
| Size              | Part Number     | Ctn Qty     | Approx Net Wt. | Dimensions |       |       |        |       |
| 3" x 3" x 3" x 2" | 06009           | 10          | 2.64           | A          | B     | C     | D      | E     |
|                   |                 |             |                | 6-5/8      | 7-1/2 | 7-1/2 | 2-1/16 | 4-1/4 |

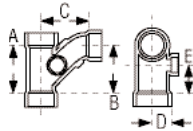
**WYE • COMBINATION • 1/8 BEND • W/RIGHT SIDE INLET****PVC DWV****P516**

(TWO PIECE)

| CONNECTION        | CHARLOTTE STYLE | NIBCO STYLE | LASCO STYLE    |            |       |       |        |       |
|-------------------|-----------------|-------------|----------------|------------|-------|-------|--------|-------|
| <b>ALL HUB</b>    | 516             | N/A         | N/A            |            |       |       |        |       |
| Size              | Part Number     | Ctn Qty     | Approx Net Wt. | Dimensions |       |       |        |       |
| 3" x 3" x 3" x 2" | 06008           | 10          | 2.59           | A          | B     | C     | D      | E     |
|                   |                 |             |                | 6-5/8      | 7-1/2 | 7-1/2 | 2-1/16 | 4-1/4 |

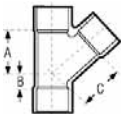
**WYE****PVC DWV****P600**

| CONNECTION     | CHARLOTTE STYLE | NIBCO STYLE | LASCO STYLE    |            |        |        |   |   |
|----------------|-----------------|-------------|----------------|------------|--------|--------|---|---|
| <b>ALL HUB</b> | 600             | 4810        | D600           |            |        |        |   |   |
| Size           | Part Number     | Ctn Qty     | Approx Net Wt. | Dimensions |        |        |   |   |
| 1-1/4"         | 05816           | 35          | .31            | A          | B      | C      | D | E |
| 1-1/2"         | 05822           | 50          | .39            | 2-9/16     | 1-1/16 | 2-9/16 |   |   |
| 2"             | 05823           | 25          | .60            | 2-7/8      | 1-1/8  | 2-7/8  |   |   |
| 3"             | 05824           | 25          | 1.72           | 3-5/8      | 1-3/8  | 3-5/8  |   |   |
| 4"             | 05825           | 5           | 3.14           | 5          | 1-5/8  | 5      |   |   |
| 6"             | 06135           | 4           | 6.66           | 63-8       | 1-7/8  | 6-3/8  |   |   |
| 8"             | 06139           | 1           | 14.70          | 8-7/16     | 1-3/4  | 8-7/16 |   |   |
|                |                 |             |                | 11-3/4     | 2-3/8  | 11-3/4 |   |   |

**WYE • REDUCING**

**PVC DWV**

**P601**

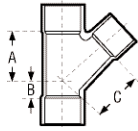
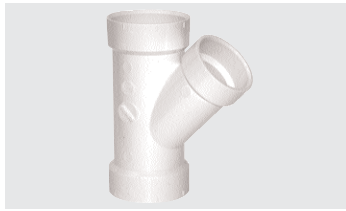

| CONNECTION<br><b>ALL HUB</b> | CHARLOTTE STYLE<br>601 | NIBCO STYLE<br>4810 | LASCO STYLE<br>D601 |         |        |         |   |   |
|------------------------------|------------------------|---------------------|---------------------|---------|--------|---------|---|---|
| Size                         | Part Number            | Ctn Qty             | Approx Net Wt.      | A       | B      | C       | D | E |
| 2" x 1-1/2" x 1-1/2"         | 05831                  | 25                  | .47                 | 2-13/16 | 3/4    | 2-15/16 |   |   |
| 2" x 1-1/2" x 2"             | 05832                  | 50                  | .66                 | 3/2     | 1      | 3-3/8   |   |   |
| 2" x 2" x 1-1/2"             | 05826                  | 25                  | .52                 | 3-5/16  | 1-1/16 | 3-7/16  |   |   |
| 3" x 3" x 1-1/2"             | 05827                  | 15                  | 1.07                | 3-3/4   | 1/2    | 4-5/16  |   |   |
| 3" x 3" x 2"                 | 05828                  | 25                  | 1.17                | 4-1/8   | 7/8    | 4-5/8   |   |   |
| 4" x 4" x 1-1/2"             | 05833                  | 5                   | 1.89                | 3-5/16  | 0      | 3-15/16 |   |   |
| 4" x 4" x 2"                 | 05829                  | 10                  | 1.86                | 4-11/16 | 3/8    | 5-9/16  |   |   |
| 4" x 4" x 3"                 | 05830                  | 10                  | 2.41                | 5-9/16  | 1-1/16 | 6       |   |   |
| 6" x 6" x 3"                 | 06138                  | 5                   | 5.01                | 6-15/16 | 3/16   | 7-7/16  |   |   |
| 6" x 6" x 4"                 | 06137                  | 5                   | 5.01                | 6-11/16 | 3/16   | 7-7/16  |   |   |
| 8" x 8" x 6"                 | 05834                  | 1                   | 10.72               | 9-1/2   | 1      | 9-13/16 |   |   |

**WYE • STREET**

**PVC DWV**

**P602**

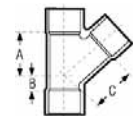

| CONNECTION<br><b>SP x H x H</b> | CHARLOTTE STYLE<br>602 | NIBCO STYLE<br>4810-2 | LASCO STYLE<br>D602 |       |         |       |   |   |
|---------------------------------|------------------------|-----------------------|---------------------|-------|---------|-------|---|---|
| Size                            | Part Number            | Ctn Qty               | Approx Net Wt.      | A     | B       | C     | D | E |
| 1-1/2"                          | 06367                  | 50                    | .38                 | 2-7/8 | 1-13/16 | 2-7/8 |   |   |
| 2"                              | 06368                  | 30                    | .56                 | 3-5/8 | 2-1/8   | 3-5/8 |   |   |
| 3"                              | 06369                  | 10                    | 1.66                | 5     | 3-1/8   | 5     |   |   |
| 4"                              | 06370                  | 5                     | 2.98                | 6-3/8 | 3-5/8   | 6-3/8 |   |   |

**WYE • STREET • REDUCING**

**PVC DWV**

**P603**

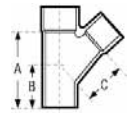

| CONNECTION<br><b>SP x H x H</b> | CHARLOTTE STYLE<br>603 | NIBCO STYLE<br>4810-2 | LASCO STYLE<br>D603 |         |         |              |   |   |   |
|---------------------------------|------------------------|-----------------------|---------------------|---------|---------|--------------|---|---|---|
| Size                            | Part Number            | Ctn Qty               | Approx Net Wt.      | A       | B       | Dimensions C | D | E | F |
| 3" x 3" x 1-1/2"                | 06372                  | 20                    | 1.02                | 3-3/4   | 2       | 4-5/16       |   |   |   |
| 3" x 3" x 2"                    | 06373                  | 30                    | 1.11                | 4-1/8   | 2-3/8   | 4-5/8        |   |   |   |
| 4" x 4" x 2"                    | 06374                  | 10                    | 1.74                | 4-11/16 | 2-1/8   | 5-9/16       |   |   |   |
| 4" x 4" x 3"                    | 06375                  | 10                    | 2.30                | 5-9/16  | 2-13/16 | 6            |   |   |   |



## WYE • DOUBLE

## PVC DWV

## P611

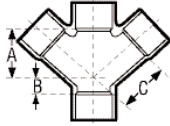

| CONNECTION<br><b>ALL HUB</b> | CHARLOTTE STYLE<br>611 | NIBCO STYLE<br>4834 | LASCO STYLE<br>D611 |            |       |        |   |   |
|------------------------------|------------------------|---------------------|---------------------|------------|-------|--------|---|---|
| Size                         | Part<br>Number         | Ctn<br>Qty          | Approx<br>Net Wt.   | Dimensions |       |        |   |   |
|                              |                        |                     |                     | A          | B     | C      | D | E |
| 1-1/2"                       | 05838                  | 40                  | .49                 | 2-7/8      | 1-1/8 | 2-7/8  |   |   |
| 2"                           | 05839                  | 20                  | .78                 | 3-5/8      | 1-3/8 | 3-5/8  |   |   |
| 3"                           | 05840                  | 10                  | 2.17                | 5          | 1-5/8 | 5      |   |   |
| 4"                           | 05841                  | 5                   | 3.83                | 6-3/8      | 1-7/8 | 6-3/8  |   |   |
| 6"                           | 05842                  | 2                   | 5.00                | 8-7/16     | 1-3/4 | 8-7/16 |   |   |

## WYE • DOUBLE • W/SIDE INLET

## PVC DWV

## P611S

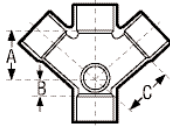

| CONNECTION<br><b>ALL HUB</b> | CHARLOTTE STYLE<br>611-S | NIBCO STYLE<br>N/A | LASCO STYLE<br>D610 |            |   |   |   |   |
|------------------------------|--------------------------|--------------------|---------------------|------------|---|---|---|---|
| Size                         | Part<br>Number           | Ctn<br>Qty         | Approx<br>Net Wt.   | Dimensions |   |   |   |   |
|                              |                          |                    |                     | A          | B | C | D | E |
| 3" x 3" x 3" x 3" x 2"       | 05849                    | 10                 | 2.23                |            |   |   |   |   |

## WYE • DOUBLE • REDUCING

## PVC DWV

## P612

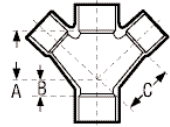

| CONNECTION<br><b>ALL HUB</b> | CHARLOTTE STYLE<br>612 | NIBCO STYLE<br>4834 | LASCO STYLE<br>D612 |            |        |        |   |   |
|------------------------------|------------------------|---------------------|---------------------|------------|--------|--------|---|---|
| Size                         | Part<br>Number         | Ctn<br>Qty          | Approx<br>Net Wt.   | Dimensions |        |        |   |   |
|                              |                        |                     |                     | A          | B      | C      | D | E |
| 2" x 2" x 1-1/2" x 1-1/2"    | 05847                  | 10                  | .63                 | 3-5/16     | 1-1/16 | 3-7/16 |   |   |
| 3" x 3" x 1-1/2" x 1-1/2"    | 05843                  | 10                  | 1.13                | 3-3/4      | 1/2    | 4-5/16 |   |   |
| 3" x 3" x 2" x 2"            | 05844                  | 10                  | 1.35                | 4-1/8      | 7/8    | 4-5/8  |   |   |
| 4" x 4" x 2" x 2"            | 05845                  | 5                   | 2.00                | 4-11/16    | 3/8    | 5-9/16 |   |   |
| 4" x 4" x 3" x 3"            | 05846                  | 5                   | 2.93                | 5-9/16     | 1-1/16 | 6      |   |   |
| 6" x 6" x 4" x 4"            | 06142                  | 3                   | 5.71                | 6-11/16    | 3/16   | 7-7/16 |   |   |

## WYE • W/LEFT SIDE INLET

## PVC DWV

## P625

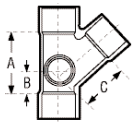

| CONNECTION<br><b>ALL HUB</b> | CHARLOTTE STYLE<br>625 | NIBCO STYLE<br>N/A | LASCO STYLE<br>D625 |            |        |        |   |   |
|------------------------------|------------------------|--------------------|---------------------|------------|--------|--------|---|---|
| Size                         | Part<br>Number         | Ctn<br>Qty         | Approx<br>Net Wt.   | Dimensions |        |        |   |   |
|                              |                        |                    |                     | A          | B      | C      | D | E |
| 3" x 3" x 3" x 2"            | 06155                  | 5                  | 1.99                | 6-1/2      | 2-3/16 | 5      |   |   |
| 4" x 4" x 4" x 2"            | 06157                  | 5                  | 3.53                | 8          | 2-1/2  | 6-3/16 |   |   |

**WYE • W/RIGHT SIDE INLET**

**PVC DWV**

**P626**

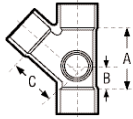

| CONNECTION<br><b>ALL HUB</b> | CHARLOTTE STYLE<br>626 | NIBCO STYLE<br>N/A | LASCO STYLE<br>D625 |            |        |        |   |   |
|------------------------------|------------------------|--------------------|---------------------|------------|--------|--------|---|---|
| Size                         | Part Number            | Ctn Qty            | Approx Net Wt.      | Dimensions |        |        |   |   |
|                              |                        |                    |                     | A          | B      | C      | D | E |
| 3" x 3" x 3" x 2"            | 06156                  | 5                  | 1.99                | 6-1/2      | 2-3/16 | 5      |   |   |
| 4" x 4" x 4" x 2"            | 06158                  | 5                  | 3.53                | 8          | 2-1/2  | 6-3/16 |   |   |

**RETURN BEND**

**PVC DWV**

**P700**

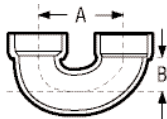

| CONNECTION<br><b>H x H</b> | CHARLOTTE STYLE<br>700 | NIBCO STYLE<br>4879 | LASCO STYLE<br>D700 |            |         |         |   |   |   |
|----------------------------|------------------------|---------------------|---------------------|------------|---------|---------|---|---|---|
| Size                       | Part Number            | Ctn Qty             | Approx Net Wt.      | Dimensions |         |         |   |   |   |
|                            |                        |                     |                     | A          | B       | C       | D | E | F |
| 1-1/2"                     | 06466                  | 20                  | .34                 | 3-1/2      | 1-17/32 |         |   |   |   |
| 2"                         | 06467                  | 35                  | .60                 | 5-1/4      | 2-3/8   |         |   |   |   |
| 3"                         | 06468                  | 10                  | 1.77                | 6-3/4      |         | 3       |   |   |   |
| 4"                         | 06469                  | 5                   | 3.13                | 8-9/16     |         | 3-11/16 |   |   |   |

**RETURN BEND • W/CLEANOUT**

**PVC DWV**

**P701**

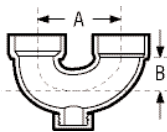

| CONNECTION<br><b>H x H</b> | CHARLOTTE STYLE<br>N/A | NIBCO STYLE<br>4878 | LASCO STYLE<br>N/A |            |       |   |   |   |   |
|----------------------------|------------------------|---------------------|--------------------|------------|-------|---|---|---|---|
| Size                       | Part Number            | Ctn Qty             | Approx Net Wt.     | Dimensions |       |   |   |   |   |
|                            |                        |                     |                    | A          | B     | C | D | E | F |
| 1-1/2"                     | 06471                  | 20                  | .36                | 3-1/16     | 1-3/8 |   |   |   |   |
| 2"                         | 06472                  | 10                  | .67                | 5-1/32     | 2-1/4 |   |   |   |   |

**ADAPTER • TAIL PIECE • W/PLASTIC NUT**

**PVC DWV**

**P704P**

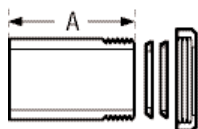

| CONNECTION<br><b>SP x SJ</b> | CHARLOTTE STYLE<br>704-P | NIBCO STYLE<br>N/A | LASCO STYLE<br>N/A |            |   |   |   |   |   |
|------------------------------|--------------------------|--------------------|--------------------|------------|---|---|---|---|---|
| Size                         | Part Number              | Ctn Qty            | Approx Net Wt.     | Dimensions |   |   |   |   |   |
|                              |                          |                    |                    | A          | B | C | D | E | F |
| 1-1/2" x 1-1/2"              | 05975                    | 25                 | .13                | 2-5/8      |   |   |   |   |   |
| OR<br>1-1/2" x 1-1/4"        | 05975                    | 25                 | .13                | 2-5/8      |   |   |   |   |   |

(FURNISHED W/BOTH SIZE SJ WASHERS)



TUBE & PIPE

METAL FITTINGS & NIPPLES

PLASTIC FITTINGS

VALVES

FILTER-DRYERS & STRAINERS

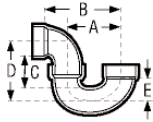
**P - TRAP • W/SOLVENT WELD JOINT****PVC DWV****P706X**

| CONNECTION<br>H x H | CHARLOTTE STYLE<br>706-P | NIBCO STYLE<br>4885 | LASCO STYLE<br>D706 | Dimensions |         |         |        |         |
|---------------------|--------------------------|---------------------|---------------------|------------|---------|---------|--------|---------|
| Size                | Part<br>Number           | Ctn<br>Qty          | Approx<br>Net Wt.   | A          | B       | C       | D      | E       |
| 1-1/2"              | 05214                    | 25                  | .51                 | 3-1/2      | 4-23/32 | 2-11/32 | 3-5/8  | 1-17/32 |
| 2"                  | 05222                    | 20                  | .87                 | 5-1/4      | 6-7/8   | 2-7/8   | 5-1/8  | 2-3/8   |
| 3"                  | 05230                    | 10                  | 2.75                | 6-3/4      | 9-15/16 | 4-11/16 | 7-5/8  | 3       |
| 4"                  | 05231                    | 4                   | 4.88                | 8-9/16     | 12-7/16 | 5-1/4   | 7-9/16 | 3-11/16 |

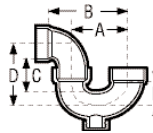
**P - TRAP • W/SOLVENT WELD JOINT & CLEANOUT****PVC DWV****P707X**

| CONNECTION<br>H x H | CHARLOTTE STYLE<br>707-X | NIBCO STYLE<br>4884 | LASCO STYLE<br>D707 | Dimensions |        |       |       |       |
|---------------------|--------------------------|---------------------|---------------------|------------|--------|-------|-------|-------|
| Size                | Part<br>Number           | Ctn<br>Qty          | Approx<br>Net Wt.   | A          | B      | C     | D     | E     |
| 1-1/2"              | 05223                    | 10                  | .55                 | 3-1/16     | 4-9/32 | 2-1/8 | 3-5/8 | 1-3/8 |
| 2"                  | 05224                    | 10                  | .88                 | 5-1/32     | 6-3/8  | 2-1/2 | 5     | 2-1/4 |

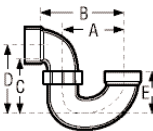
**P-TRAP • W/UNION****PVC DWV****P708P**

| CONNECTION<br>H x H | CHARLOTTE STYLE<br>708-P | NIBCO STYLE<br>4895 | LASCO STYLE<br>D708 | Dimensions |         |         |       |         |
|---------------------|--------------------------|---------------------|---------------------|------------|---------|---------|-------|---------|
| Size                | Part<br>Number           | Ctn<br>Qty          | Approx<br>Net Wt.   | A          | B       | C       | D     | E       |
| 1-1/4"              | 05921                    | 50                  | .48                 | 3          | 4-1/8   | 2-1/16  | 3-3/8 | 1-3/8   |
| 1-1/2"              | 05215                    | 25                  | .57                 | 3-1/2      | 4-23/32 | 2-11/32 | 3-5/8 | 1-17/32 |
| 2"                  | 05216                    | 20                  | .94                 | 5-1/4      | 6-7/8   | 2-7/8   | 5-1/8 | 2-3/8   |

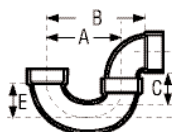
**P-TRAP • LOW PROFILE • W/SOLVENT WELD JOINT****PVC DWV****P710**

| CONNECTION<br>H x H | CHARLOTTE STYLE<br>N/A | NIBCO STYLE<br>N/A | LASCO STYLE<br>N/A | Dimensions |       |        |       |       |
|---------------------|------------------------|--------------------|--------------------|------------|-------|--------|-------|-------|
| Size                | Part<br>Number         | Ctn<br>Qty         | Approx<br>Net Wt.  | A          | B     | C      | D     | E     |
| 2"                  | 05225                  | 20                 | .87                | 5-1/4      | 6-7/8 | 2-3/16 | 4-3/4 | 2-1/4 |

**LA TRAP W/UNION AND 1-1/2 & 1-1/4 SJ WASHERS • PLASTIC NUT PVC DWV**

**P711P**

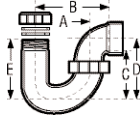

| CONNECTION<br><b>SJ x H</b> | CHARLOTTE STYLE<br>711-P | NIBCO STYLE<br>4893 | LASCO STYLE<br>D711 | Dimensions |   |       |   |    |   |
|-----------------------------|--------------------------|---------------------|---------------------|------------|---|-------|---|----|---|
| Size                        | Part Number              | Ctn Qty             | Approx Net Wt.      | A          | B | C     | D | E* | F |
| 1-1/4" x 1-1/2"             | 05220                    | 25                  | .71                 | 3-13/16    | 5 | 2-1/2 | 4 | 4  |   |
| AND<br>1-1/2" x 1-1/2"      |                          |                     |                     |            |   |       |   |    |   |

(FURNISHED W/BOTH SIZE SJ WASHERS) \*TO TOP OF NUT

**DRUM TRAP • W/CLEANOUT PVC DWV**

**P720X**

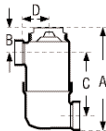

| CONNECTION<br><b>H x H</b> | CHARLOTTE STYLE<br>720X | NIBCO STYLE<br>4891 | LASCO STYLE<br>D720 | Dimensions |   |       |       |   |   |
|----------------------------|-------------------------|---------------------|---------------------|------------|---|-------|-------|---|---|
| Size                       | Part Number             | Ctn Qty             | Approx Net Wt.      | A          | B | C     | D     | E | F |
| 1-1/2" x 3" x 6"           | 06100                   | 10                  | 1.29                | 7-13/16    | 3 | 4-1/2 | 1-1/2 |   |   |

(W/PLUG)

**CLOSET FLANGE PVC DWV**

**P800**

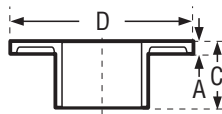

| CONNECTION<br><b>H</b> | CHARLOTTE STYLE<br>800 | NIBCO STYLE<br>4851 | LASCO STYLE<br>D800 | Dimensions |   |   |   |   |   |
|------------------------|------------------------|---------------------|---------------------|------------|---|---|---|---|---|
| Size                   | Part Number            | Ctn Qty             | Approx Net Wt.      | A          | B | C | D | E | F |
| 4"                     | 05902                  | 25                  | .68                 | 7/16       | - | 2 | 7 |   |   |

(ONE PIECE W/SLOTS)

**CLOSET FLANGE • KNOCKOUT PVC DWV**

**P800KO**

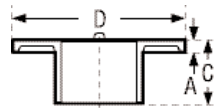
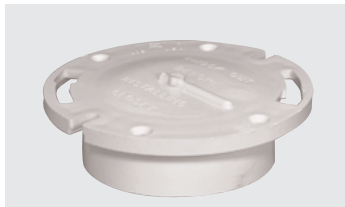

| CONNECTION<br><b>H</b> | CHARLOTTE STYLE<br>800-KO | NIBCO STYLE<br>4855 | LASCO STYLE<br>D815 | Dimensions |   |   |   |   |   |
|------------------------|---------------------------|---------------------|---------------------|------------|---|---|---|---|---|
| Size                   | Part Number               | Ctn Qty             | Approx Net Wt.      | A          | B | C | D | E | F |
| 4"                     | 05253                     | 25                  | .75                 | 7/16       | - | 2 | 7 |   |   |
| 4" x 3"                | 05254                     | 25                  | .81                 | 7/16       | - | 2 | 7 |   |   |

(ONE PIECE W/SLOTS & KNOCKOUT TEST CAP)

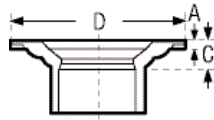
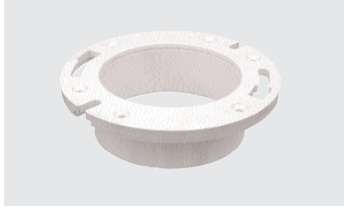

**CLOSET FLANGE • W/STOP****PVC DWV****P800S**

(ONE PIECE W/SLOTS)

| CONNECTION<br><b>H</b> | CHARLOTTE STYLE<br>800-S | NIBCO STYLE<br>N/A | LASCO STYLE<br>N/A | Dimensions |       |   |   |   |   |
|------------------------|--------------------------|--------------------|--------------------|------------|-------|---|---|---|---|
| Size                   | Part<br>Number           | Ctn<br>Qty         | Approx<br>Net Wt.  | A          | B     | C | D | E | F |
| 4" x 3"                | 05903                    | 25                 | .78                | 7/16       | 1-1/4 | - | 7 |   |   |

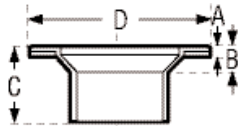
**CLOSET FLANGE • SPIGOT • REDUCING****PVC DWV****P801**

(ONE PIECE)

| CONNECTION<br><b>SP</b> | CHARLOTTE STYLE<br>801 | NIBCO STYLE<br>4851-4 | LASCO STYLE<br>D801 | Dimensions |       |       |   |   |   |
|-------------------------|------------------------|-----------------------|---------------------|------------|-------|-------|---|---|---|
| Size                    | Part<br>Number         | Ctn<br>Qty            | Approx<br>Net Wt.   | A          | B     | C     | D | E | F |
| 4" x 3"                 | 05919                  | 25                    | .71                 | 7/16       | 1-1/4 | 2-3/4 | 7 |   |   |

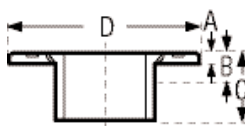
**CLOSET FLANGE • ADJUSTABLE • W/PLASTIC RING****PVC DWV****P810**

(W/SLOTS)

| CONNECTION<br><b>H</b> | CHARLOTTE STYLE<br>810 | NIBCO STYLE<br>N/A | LASCO STYLE<br>D810 | Dimensions |   |       |   |   |   |
|------------------------|------------------------|--------------------|---------------------|------------|---|-------|---|---|---|
| Size                   | Part<br>Number         | Ctn<br>Qty         | Approx<br>Net Wt.   | A          | B | C     | D | E | F |
| 4"                     | 05256                  | 25                 | .67                 | 1/2        | - | 2-1/4 | 7 |   |   |

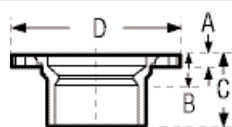
**CLOSET FLANGE • W/PIPE STOP ADJUSTABLE • W/PLASTIC RING****PVC DWV****P801**

(W/SLOTS)

| CONNECTION<br><b>H</b> | CHARLOTTE STYLE<br>N/A | NIBCO STYLE<br>N/A | LASCO STYLE<br>N/A | Dimensions |       |       |   |   |   |
|------------------------|------------------------|--------------------|--------------------|------------|-------|-------|---|---|---|
| Size                   | Part<br>Number         | Ctn<br>Qty         | Approx<br>Net Wt.  | A          | B     | C     | D | E | F |
| 3" x 4"                | 05251                  | 25                 | .80                | 1/2        | 1-1/4 | 2-3/4 | 7 |   |   |

**CLOSET FLANGE • ADJUSTABLE • W/METAL RING • EPOXY COATED PVC DWV**

**P811**

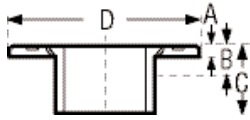

(W/SLOTS)

| CONNECTION<br><b>H</b> | CHARLOTTE STYLE<br>811 | NIBCO STYLE<br>4851-A |                | LASCO STYLE<br>D811 |       |       |   |   |   |
|------------------------|------------------------|-----------------------|----------------|---------------------|-------|-------|---|---|---|
| Size                   | Part Number            | Ctn Qty               | Approx Net Wt. | Dimensions          |       |       |   |   |   |
|                        |                        |                       |                | A                   | B     | C     | D | E | F |
| 4"                     | 05226                  | 25                    | .70            | 5/16                | —     | 2     | 7 |   |   |
| 4" x 3"                | 05227                  | 25                    | .83            | 5/16                | 1-1/4 | 2-3/4 | 7 |   |   |

**CLOSET FLANGE • SPIGOT • ADJUSTABLE W/METAL RING • EPOXY COATED PVC DWV**

**P812**

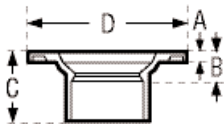

| CONNECTION<br><b>SP</b> | CHARLOTTE STYLE<br>812 | NIBCO STYLE<br>4851-2-A |                | LASCO STYLE<br>D812 |       |       |   |   |   |
|-------------------------|------------------------|-------------------------|----------------|---------------------|-------|-------|---|---|---|
| Size                    | Part Number            | Ctn Qty                 | Approx Net Wt. | Dimensions          |       |       |   |   |   |
|                         |                        |                         |                | A                   | B     | C     | D | E | F |
| 4" x 3"                 | 05228                  | 25                      | .76            | 5/16                | 1-1/4 | 2-1/4 | 7 |   |   |
| 4"                      | 05229                  | 25                      | 1.19           | 5/16                | —     | 2-1/4 | 7 |   |   |

**CLOSET FLANGE • SPIGOT • ADJUSTABLE W/PLASTIC RING PVC DWV**

**P812P**

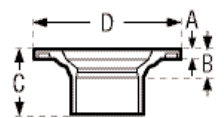

| CONNECTION<br><b>SP</b> | CHARLOTTE STYLE<br>N/A | NIBCO STYLE<br>N/A |                | LASCO STYLE<br>N/A |       |       |   |   |   |
|-------------------------|------------------------|--------------------|----------------|--------------------|-------|-------|---|---|---|
| Size                    | Part Number            | Ctn Qty            | Approx Net Wt. | Dimensions         |       |       |   |   |   |
|                         |                        |                    |                | A                  | B     | C     | D | E | F |
| 4" x 3"                 | 05252                  | 25                 | .72            | 1/2                | 1-1/4 | 2-3/4 | 7 |   |   |
| 4"                      | 05264                  | 25                 | .75            | 1/2                | —     | 2-1/4 | 7 |   |   |

TUBE & PIPE

METAL FITTINGS & NIPPLES

PLASTIC FITTINGS

VALVES

FILTER-DRYERS & STRAINERS

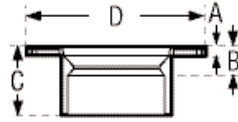

**CLOSET FLANGE • FLUSH****PVC DWV****P815**

| CONNECTION<br><b>SP &amp; H</b> | CHARLOTTE STYLE<br>815 | NIBCO STYLE<br>4853 | LASCO STYLE<br>N/A | Dimensions |       |       |   |   |   |
|---------------------------------|------------------------|---------------------|--------------------|------------|-------|-------|---|---|---|
| Size                            | Part<br>Number         | Ctn<br>Qty          | Approx<br>Net Wt.  | A          | B     | C     | D | E | F |
| 4" x 4" x 4" x 3"               | 05255                  | 25                  | .64                | 1/2        | 1-1/4 | 2-3/4 | 7 |   |   |

(FITS OVER 3" OR INSIDE 4" SCH. 40 DWV PIPE)

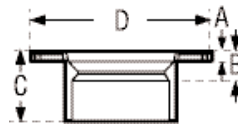
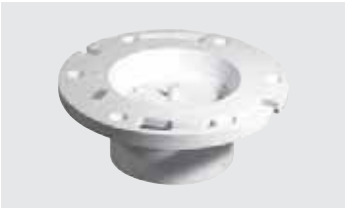
**CLOSET FLANGE • FLUSH • KNOCKOUT****PVC DWV****P815KO**

| CONNECTION<br><b>SP &amp; H</b> | CHARLOTTE STYLE<br>815KO | NIBCO STYLE<br>4853KO | LASCO STYLE<br>D815 | Dimensions |       |       |   |   |   |
|---------------------------------|--------------------------|-----------------------|---------------------|------------|-------|-------|---|---|---|
| Size                            | Part<br>Number           | Ctn<br>Qty            | Approx<br>Net Wt.   | A          | B     | C     | D | E | F |
| 4" x 4" x 4" x 3"               | 05257                    | 25                    |                     | 1/2        | 1-1/4 | 2-3/4 | 7 |   |   |

(FITS OVER 3" OR INSIDE 4" SCH. 40 DWV PIPE)

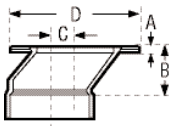
**CLOSET FLANGE • OFFSET • ADJUSTABLE W/METAL RING • EPOXY COATED****PVC DWV****P820**

| CONNECTION<br><b>H</b> | CHARLOTTE STYLE<br>820 | NIBCO STYLE<br>4848-A | LASCO STYLE<br>D823 | Dimensions |       |       |   |   |   |
|------------------------|------------------------|-----------------------|---------------------|------------|-------|-------|---|---|---|
| Size                   | Part<br>Number         | Ctn<br>Qty            | Approx<br>Net Wt.   | A          | B     | C     | D | E | F |
| 4" x 3"                | 05920                  | 15                    | 1.14                | 5/16       | 2-3/4 | 1-1/2 | 7 |   |   |

# Refrigeration Valves



Mueller is the known and trusted name in HVAC and Refrigeration products. Mueller's line of HVAC/ Refrigeration Valves, Valve Kits, and other components have been designed to provide optimum system performance and enhanced serviceability for many of today's applications. All valves are made to the highest quality and testing standards and incorporate many industry leading features and exclusive technologies only found in quality Mueller products. From wide operating temperature ranges and compatibility with the newer refrigerants and oils to forged brass bodies and full port openings, Mueller's expansive line of HVAC/Refrigeration products have the features that ensure the performance you expect.

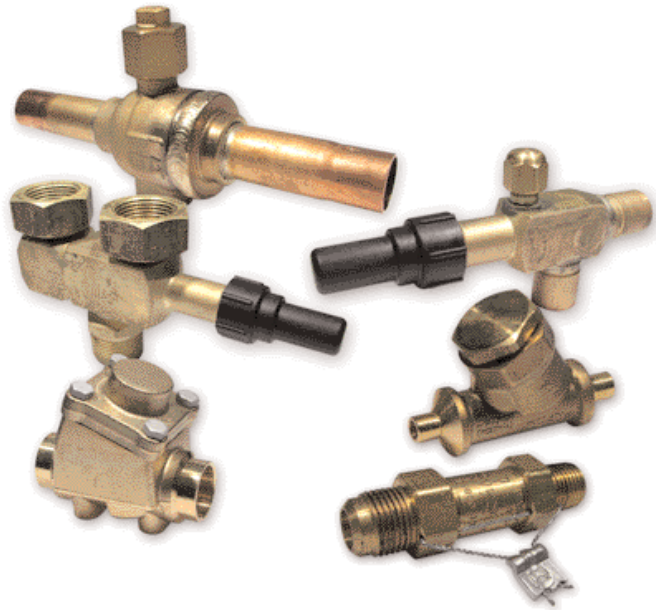

TUBE & PIPE

METAL FITTINGS & NIPPLES

PLASTIC FITTINGS

VALVES

FILTER-DRYERS & STRAINERS

## CYCLEMASTER® ACTUATED BALL VALVES

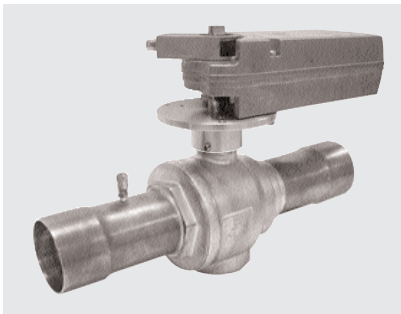

- Full port construction to match line size I.D.
- Quarter turn operation, with ball position indicated by arrow.
- Full shutoff capability.
- Dual pin stops.
- Gradual open/close stops line hammer.
- Chromium plated ball.
- Nylon anti-friction ring.
- Exclusive MCM™ leak-free seals.
- Compatible with all new refrigerant and oils.
- Remote operating capability.
- Removable actuator for quick change replacement.
- Manual override and valve positioning.
- Electronic overload protection.
- Models available with auxiliary switch.
- All valves 100% tested, UL/cUL listed and CE certified.

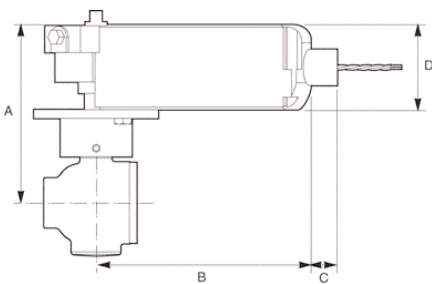

| Straight |          |      |      |     |      | 3-Way    |      |      |     |      |
|----------|----------|------|------|-----|------|----------|------|------|-----|------|
| Size     | Part No. | A    | B    | C   | D    | Part No. | A    | B    | C   | D    |
| 1/2      | AW17861  | 4.05 | 3.71 | NA  | 2.69 | AY17861  | 4.05 | 3.71 | NA  | 2.69 |
| 5/8      | AW17862  | 4.05 | 3.71 | NA  | 2.69 | AY17862  | 4.05 | 3.71 | NA  | 2.69 |
| 3/4      | AW17863  | 4.36 | 3.71 | NA  | 2.69 | AY17863  | 4.36 | 3.71 | NA  | 2.69 |
| 7/8      | AW17864  | 4.36 | 3.71 | NA  | 2.69 | AY17864  | 4.36 | 3.71 | NA  | 2.69 |
| 1-1/8    | AW17865  | 4.89 | 5.75 | .65 | 3.18 | AY17865  | 4.89 | 5.75 | .65 | 3.18 |
| 1-3/8    | AW17866  | 5.12 | 5.75 | .65 | 3.18 | AY17866  | 5.70 | 5.75 | .65 | 3.18 |
| 1-5/8    | AW17867  | 5.84 | 5.75 | .65 | 3.18 | AY17867  | 6.19 | 5.75 | .65 | 3.18 |
| 2-1/8    | AW17868  | 6.50 | 8.25 | .67 | 3.93 | A 17812  | 6.50 | 8.25 | .67 | 3.93 |
| 2-5/8    | AW17871  | 6.50 | 8.25 | .67 | 3.93 | A 17813  | 6.50 | 8.25 | .67 | 3.93 |
| 3-1/8    | AW17872  | 6.50 | 8.25 | .67 | 3.93 | A 17814  | 6.50 | 8.25 | .67 | 3.93 |

| Actuated Kits |          |         |
|---------------|----------|---------|
| Size          | Straight | 3-Way   |
| 1/2           | B 34437  | B 34437 |
| 5/8           | B 34437  | B 34437 |
| 3/4           | B 34438  | B 34438 |
| 7/8           | B 34438  | B 34438 |
| 1 1/8         | B 34439  | B 34439 |
| 1 3/8         | ---      | B 34440 |
| 1 5/8         | B 34440  | B 34441 |
| 2 1/8         | B 34441  | B 34442 |
| 2 5/8         | B 34441  | B 34442 |
| 3 1/8         | B 34441  | B 34442 |

| Actuated Ball Valve Accessories |                |                       |
|---------------------------------|----------------|-----------------------|
| Part No.                        | Accessory      | For Use with Actuator |
| P 36532                         | Housing        | Series II             |
| P 36533                         | Heater         | Series II             |
| P 36534                         | Heated Housing | Series II             |
| P 36535                         | Housing        | Series III            |
| P 36536                         | Heater         | Series III            |
| P 36537                         | Heated Housing | Series III            |



## CYCLEMASTER® BALL VALVES

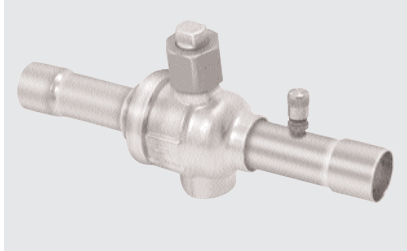

- Full port construction from sizes 1/4" through 3/16" to match line size I.D.
- Chromium plated ball reduces frictional wear, extends seal life and is an environmentally friendly component.
- Exclusive MCM™ seals that provide industry leading longevity and immeasurably low leak rates.
- Quick-turn cap provides visual identification of stem position and enhances serviceability in tight spaces.
- Flexible body forging that allows optional surface mount configuration.
- Dual pin stops.
- Optional features include access ports, drilled and tapped, one-piece seal caps and 3-way body styles.
- Compatible with all CFC, HCFC, and HFC refrigerants and oils.
- Wide operating temperature range of -40°F to 300°F, and working pressures up to 700 psig.
- All valves are 100% tested, UL/cUL listed and CE certified.

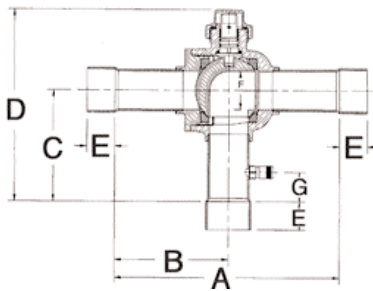
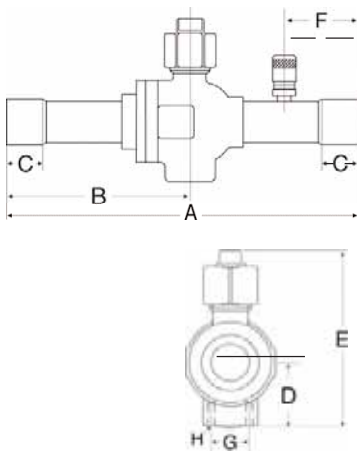

## CYCLEMASTER® BALL VALVE

| Part No. | Size  | Cv     | A (in) | B (in)  | C (in)  | D (in)  | E (in)  | F** (in) | G** (mm) | Port Size | H**      | Wt.   |
|----------|-------|--------|--------|---------|---------|---------|---------|----------|----------|-----------|----------|-------|
| A 17859• | 1/4   | 1.02   | 5-7/16 | 2-15/16 | 5/16    | 7/8     | 2-3/4   | NA       | 14       | 1/2       | M4 X 0.7 | .70   |
| A 17860• | 3/8   | 4.29   | 5-1/2  | 3       | 5/16    | 7/8     | 2-3/4   | 15/16    | 14       | 1/2       | M4 X 0.7 | .63   |
| A 17861• | 1/2   | 6.20   | 6-3/8  | 3-7/16  | 3/8     | 7/8     | 2-3/4   | 1-3/16   | 14       | 1/2       | M4 X 0.7 | .62   |
| A 17862• | 5/8   | 11.20  | 6-3/8  | 3-7/16  | 1/2     | 7/8     | 2-3/4   | 1-3/8    | 14       | 1/2       | M4 X 0.7 | .64   |
| A 17863  | 3/4   | 18.95  | 7-7/16 | 3-7/8   | 5/8     | 1-1/4   | 3-1/2   | 1-1/2    | 20       | 3/4       | M4 X 0.7 | 1.15  |
| A 17864  | 7/8   | 29.30  | 7-7/16 | 3-7/8   | 3/4     | 1-1/4   | 3-1/2   | 1-5/8    | 20       | 3/4       | M4 X 0.7 | 1.53  |
| A 17865  | 1-1/8 | 59.55  | 8-7/16 | 4-5/16  | 7/8     | 1-9/16  | 3-13/16 | 1-3/4    | 25       | 1         | M4 X 0.7 | 2.92  |
| A 17866  | 1-3/8 | 84.58  | 10     | 5       | 1       | 1-1/2   | 4-3/16  | 2-1/16   | 30       | 1-1/4     | M6 X 1.0 | 3.48  |
| A 17867  | 1-5/8 | 225.04 | 11     | 5-1/2   | 1-1/8   | 1-11/16 | 4-7/8   | 2-1/4    | 34       | 1-1/2     | M6 X 1.0 | 5.02  |
| A 17868  | 2-1/8 | 291.59 | 12     | 6       | 1-3/8   | 2-1/8   | 5-9/16  | 2-7/16   | 34       | 2         | M6 X 1.0 | 8.60  |
| A 17869  | 2-5/8 | 423.47 | 13-1/2 | 6-13/16 | 1-1/2   | ***     | ***     | ***      | 34       | 2-9/20    | M6 X 1.0 | 14.00 |
| A 17870  | 3-1/8 | ***    | 16     | 8       | 1-3/8   | 3       | 7-3/8   | 3-1/8    | 34       | 3         | M6 X 1.0 | 23.50 |
| A 17871* | 2-5/8 | 184.85 | 12     | 6       | 1-3/8   | 2-1/8   | 5-5/8   | 2-3/8    | 34       | 2         | M6 X 1.0 | 9.20  |
| A 17872* | 3-1/8 | 127.99 | 12     | 6       | 1-11/16 | 2-1/8   | 5-5/8   | 3-1/16   | 34       | 2         | M6 X 1.0 | 11.00 |

## CYCLEMASTER® 3-WAY BALL VALVE WITH ACCESS PORTS

| Part No. | Size  | Cv    | A (in)  | B (in)  | C (in)  | D (in)  | E (in)  | F** (in) | G** (in) | Wt.   |
|----------|-------|-------|---------|---------|---------|---------|---------|----------|----------|-------|
| AU17860  | 3/8   | 2.23  | 4-7/8   | 2-21/32 | 2-19/64 | 3-21/32 | 5/16    | 1/2      | 41/64    | .67   |
| AU17861  | 1/2   | 3.94  | 5-3/8   | 3-3/64  | 2-43/64 | 4-7/32  | 3/8     | 1/2      | 53/64    | .70   |
| AU17862  | 5/8   | 4.63  | 5-3/8   | 2-59/64 | 2-35/64 | 4-7/64  | 1/2     | 1/2      | 27/32    | .70   |
| AU17863  | 3/4   | 11.90 | 6-1/4   | 3-57/64 | 3       | 5-1/4   | 5/8     | 3/4      | 55/64    | NA    |
| AU17864  | 7/8   | 10.89 | 5-31/32 | 3-5/32  | 2-29/32 | 4-7/8   | 3/4     | 3/4      | 27/32    | 1.44  |
| AU17865  | 1-1/8 | 19.33 | 6-39/64 | 3-3/16  | 3-7/64  | 5-31/64 | 29/32   | 1        | 53/64    | 2.76  |
| A 17545  | 1-3/8 | 31.06 | 8-1/16  | 4-7/64  | 3-61/64 | 6-57/64 | 3-1/32  | 1-1/4    | 1-5/64   | 4.97  |
| A 17546  | 1-5/8 | 44.69 | 8-7/8   | 4-7/16  | 4-23/64 | 7-33/64 | 1-3/32  | 1-1/2    | 1-5/32   | 7.17  |
| A 17547  | 2-1/8 | 76.32 | 9-5/16  | 4-39/64 | 4-23/32 | 8-13/32 | 1-11/32 | 2        | 1-5/64   | 13.80 |
| A 17548  | 2-5/8 | 69.85 | 9-1/16  | 4-15/32 | 4-19/32 | 8-9/32  | 1-15/32 | 2        | 1-11/64  | 14.66 |
| A 17549  | 3-1/8 | 58.19 | 8-11/16 | 4-9/32  | 4-11/32 | 8-3/32  | 1-21/32 | 2        | 1-27/64  | 15.48 |

BALL VALVE  
SEAL CAP KIT\*\*\*

| Part No. | Size  |
|----------|-------|
| A 17842  | 1/4   |
| A 17842  | 3/8   |
| A 17842  | 1/2   |
| A 17842  | 5/8   |
| A 17843  | 3/4   |
| A 17843  | 7/8   |
| A 17844  | 1-1/8 |
| A 17845  | 1-5/8 |
| A 17845  | 2-1/8 |
| A 17846  | 2-5/8 |
| A 17846  | 3-1/8 |
| A 17845  | 2-5/8 |
| A 17845  | 3-1/8 |

Prefixed for Ball Valve Options:

- A= Standard
- AC= Standard with access
- AP= Drilled & tapped
- APM= Drilled & tapped with 1-piece seal cap
- AQ= Drilled & tapped with access
- AQM= Drilled & tapped with access & 1-piece seal cap
- AU= 3-Way with access

Examples:

- A 17865, 1-1/8" without access
- AC17865, 1-1/8" with access
- API7865, 1-1/8" drilled & tapped
- APM17865, 1-1/8" drilled & tapped with 1-piece seal cap
- AQ17865, 1-1/8" drilled & tapped with access
- AQM17865, 1-1/8" drilled & tapped with access & 1-piece seal cap
- AU17865, 1-1/8" 3-way with access

\* Reduced port

\*\* Where Applicable

\*\*\* Consult factory for details

\*\*\*\* Seal Cap Kit Includes Seal Cap, Seal Cap Gasket, Anti-Friction Ring, Cap Nut

- Sizes not available in "Standard, A" or "Standard with Access, AC" options. Substitute "AP" for "A" and "AQ" for "AC".



## PACKED LINE VALVES



- Non-backseating service valves.
- Forged brass body with integral mounting bracket.
- Plated steel stem suitable for refrigerants and other industrial fluids non-corrosive to brass and steel.
- Asbestos-free stem packing material.
- Maximum temperature rating at +300°F.
- UL recognized

### ANGLE NON-BACKSEATING-INTERNAL SWIVEL FLARE

| Part No.<br>w/ Steel Cap | Part No.<br>w/ Plastic Cap | Part No.<br>w/ Brass Cap** | Internal Flare<br>A | Flare<br>B | C       | D      | E       | Wt./<br>Ea. | MWP |
|--------------------------|----------------------------|----------------------------|---------------------|------------|---------|--------|---------|-------------|-----|
| B 33803                  | A 17429                    | B 34247                    | 1/4                 | 1/4        | 1-15/32 | 1-1/16 | 3 29/32 | .33         | 700 |
| A 17474                  | -----                      | B 34261                    | 3/8                 | 3/8        | 1-1/2   | 1-1/8  | 3 9/16  | .27         | 700 |

\*\* Copper gasket included.  
One soft gasket included with each assembly

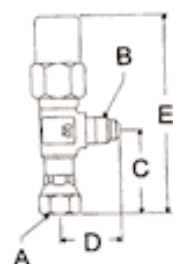

### ANGLE NON-BACKSEATING-NPTFE INLET TO FLARE†

| Part No.<br>w/ Steel Cap | Part No.<br>w/ Brass Cap** | Size     |            | Counterbore<br>Dimensions (F <sup>†</sup> ) |        |        | Wt./<br>Ea. | MWP  |       |     |
|--------------------------|----------------------------|----------|------------|---|--------|--------|-------------|------|-------|-----|
|                          |                            | MPT<br>A | Flare<br>B | C   | D      | E      |             |      | Depth |     |
| A 11031                  | A 16472                    | 1/4      | 1/4        | 1   | 15/16  | 3-3/64 | .254        | 5/16 | .26   | 700 |
| A 11030                  |                            | 1/4      | 3/8        | 1-1/16                                      | 1-1/8  | 3-3/32 | .317        | 3/8  | .31   | 700 |
| A 13613                  |                            | 3/8      | 1/4        | 1-1/8                                       | 1-1/16 | 3-3/16 | .379        | 3/8  | .31   | 700 |
| A 13503                  |                            | 3/8      | 3/8        | 1-1/8                                       | 1-1/8  | 3-5/32 | .379        | 5/16 | .33   | 700 |
| A 11042                  |                            | 3/8      | 1/2        | 1-3/8                                       | 1-3/8  | 3-3/4  | .379        | 3/8  | .51   | 700 |

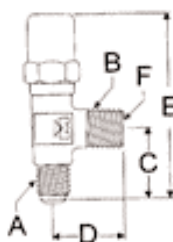

### ANGLE NON-BACKSEATING-NPTFE FLARE TO NPTFE

| Part No.<br>w/ Steel Cap | Part No.<br>w/ Brass Cap** | Size  |   |   | Counterbore<br>Dimensions (F <sup>†</sup> ) |       | Wt./Ea. | MWP |
|--------------------------|----------------------------|-------|---|---|---|-------|---------|-----|
|                          |                            | C     | D | E | Dia.  | Depth |         |     |
| A 15073                  |                            | 15/16 | 1 | 3 | .254  | 3/8   | .27     |     |

\* Machined to accept O.D. size tube as indicated.



### ANGLE NON-BACKSEATING-SOLDER TO FLARE WITH SEAL CAP

| Part No.<br>W/ Steel Cap | Part No.<br>W/ Brass<br>Cap*** | Part No.<br>Loosely<br>Assembled | C      | D      | E       | F   | Wt./Ea. | MWP |
|--------------------------|--------------------------------|----------------------------------|--------|--------|---------|-----|---------|-----|
| A 17502                  | B 34252                        | B 35161                          | 2-3/32 | 1-1/32 | 2 3/4   | 3/8 | .58     | 700 |
| A 17503                  | B 34255                        | B 35160                          | 1-1/16 | 1-1/2  | 2-23/32 | 1/2 | .49     | 700 |

\* Also 3/8 FTG. \*\*Also 1/2 FTG.

\*\*\* Copper gasket included.

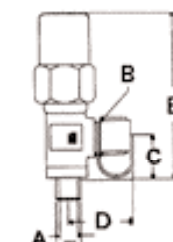

### ANGLE BACKSEATING-NPTFE INLET TO SOLDER

| Part No. | C       | D | E       | Counterbore<br>Dimensions (F <sup>†</sup> ) |       | Wt./Ea. | MWP |
|----------|---------|---|---------|---|-------|---------|-----|
|          |         |   |         | Dia.  | Depth |         |     |
| A 13977  | 1-13/16 | 1 | 4-3/32  | .504  | 3/8   | .51     | 500 |
| A 13978  | 1-13/16 | 1 | 4-11/16 | .504  | 3/8   | .61     | 500 |
| A 13979  | 2-3/32  | 1 | 6       | .754  | 5/8   | 1.27    | 700 |

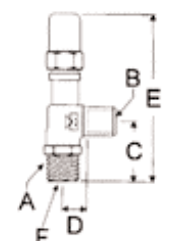

## PACKED LINE VALVES

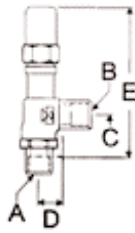

## ANGLE BACKSEATING-SOLDER TO SOLDER

| Part No. | A   | B   | C      | D     | E       | Wt./Ea. | MWP |
|----------|-----|-----|--------|-------|---------|---------|-----|
| A 17506  | 5/8 | 5/8 | 29/32  | 1     | 3-3/4   | .66     | 500 |
| B 32080  | 7/8 | 7/8 | 2-9/32 | 1-3/4 | 6-13/64 | .99     | 700 |

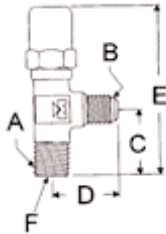

## ANGLE BACKSEATING-NPTFE INLET TO FLARE

| Part No. | Size    |         | C       | D      | E       | Counterbore Dimensions (F <sup>†</sup> ) |       | Wt./Ea. | MWP |
|----------|---------|---------|---------|--------|---------|--|-------|---------|-----|
|          | NPTFE A | Flare B |         |        |         | Dia.                                     | Depth |         |     |
| A 13220  | 1/2     | 1/2     | 1 13/16 | 1-5/16 | 4-1/8   | .504                                     | 3/8   | .53     | 500 |
| A 13183  | 1/2     | 5/8     | 1 13/16 | 1-1/2  | 4-11/16 | .504                                     | 3/8   | .64     | 500 |

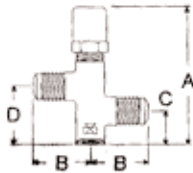

## TWO WAY-FLARE TO FLARE

| Part No.<br>W/ Steel Cap | Part No.<br>W/ Brass Cap* | Size | A       | B     | C     | D       | Wt./<br>Ea. | MWP |
|--------------------------|---------------------------|------|---------|-------|-------|---------|-------------|-----|
| A 13591                  | B 33482                   | 1/4  | 3-13/32 | 1     | 29/32 | 1-13/32 | .50         | 500 |
| A 13595                  |                           | 3/8  | 3-13/32 | 1-1/8 | 29/32 | 1-13/32 | .55         | 500 |
| A 13592                  |                           | 1/2  | 3-13/32 | 1-1/4 | 15/16 | 1-7/16  | .56         | 500 |

\* Copper gasket included

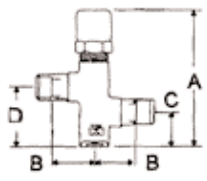

## TWO WAY-SOLDER TO SOLDER

| Part No.<br>W/ Steel Cap | Part No.<br>W/ Brass Cap* | Size | A       | B     | C     | D       | Wt./<br>Ea. | MWP |
|--------------------------|---------------------------|------|---------|-------|-------|---------|-------------|-----|
| A 15580                  | B 34883                   | 1/4  | 3-13/32 | 3/4   | 15/16 | 1-7/16  | .49         | 500 |
| A 15581                  |                           | 3/8  | 3-13/32 | 15/16 | 29/32 | 1-13/32 | .51         | 500 |
| A 15582                  |                           | 1/2  | 3-13/32 | 7/8   | 29/32 | 1-13/32 | .52         | 500 |

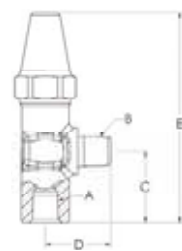

## ANGLE NON-BACKSEATING

| Part No. | A         | B         | C     | D      | E       | MWP |
|----------|-----------|-----------|-------|--------|---------|-----|
| A 13502  | 1/4 NPTFE | 1/4 NPTFI | 1-3/8 | 1-1/16 | 3-25/32 | 700 |
| B 32222  | 1/4 NPTFI | 1/4 NPTFE | 1-1/4 | 1-1/8  | 3-43/64 | 500 |

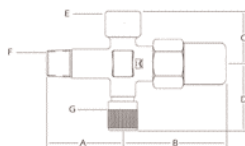

## TRANSDUCER VALVE

| Part No. | A     | B | C | D     | E         | F         | G                | Stem<br>Cap<br>Material | Valve<br>Core<br>Installed | Loosely<br>Assembled | MWP |
|----------|-------|---|---|-------|-----------|-----------|------------------|-------------------------|----------------------------|----------------------|-----|
| B 33837  | 1-1/2 | 2 | 1 | 1-1/4 | 1/8 NPTFI | 1/4 NPTFE | 1/4 Flare Access | Steel                   | No                         | No                   | 700 |
| B 34254  | 1-1/2 | 2 | 1 | 1-1/4 | 1/8 NPTFI | 1/4 NPTFE | 1/4 Flare Access | Brass                   | No                         | No                   | 700 |
| B 34287  | 1-1/2 | 2 | 1 | 1-1/4 | 1/4 NPTFI | 1/4 NPTFE | 1/4 Flare Access | Plastic                 | No                         | No                   | 700 |
| B 35162  | 1-1/2 | 2 | 1 | 1-1/4 | 1/8 NPTFI | 3/8 ODS   | 1/4 Flare Access | Steel                   | No                         | No                   | 700 |
| B 35334  | 1-1/2 | 2 | 1 | 1-1/4 | 1/4 NPTFI | 1/4 NPTFE | 1/4 Flare Access | Plastic                 | Yes                        | Yes                  | 700 |

\* Machined to accept O.D. size tube as indicated.

\*\* Copper gasket included.

† Recognized under the component program of Underwriters Laboratories for use in USA and Canada.

Replacement Caps  
A 04566-Steel  
A 04597-Brass  
P 34627-Plastic

## PACKLESS DIAPHRAGM VALVES

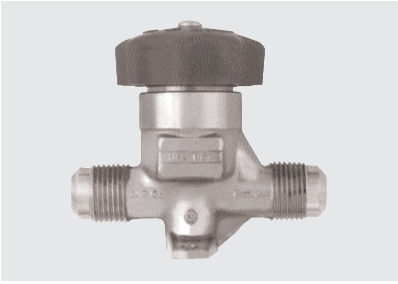

- Longevity: up to 5 times greater than current industry designs.
- Oversized diaphragms provide accurate sealing and extended wear.
- Heat stabilized nylon stem seat for use across a wide temperature range.
- Stem seat is guided in alignment, providing even wear and extended service life.
- Compatible with all new refrigerants and oils.
- Forged brass body with full size openings for maximum flow and minimum pressure drop.
- Integral mounting bracket for ease of installation.
- Available in flare, sweat, angled, and extended tubing configurations.
- All valves are 100% tested and UL/cUL recognized.
- Wide operating temperature range from -40°F to 300°F.
- Working pressure up to 500 psig with flow in direction of arrow on the body; 350 psig with flow against the direction of arrow. Burst pressure at 2500 psig.

### STRAIGHT THRU - FLARE TO FLARE - TYPE I - CLASS IV

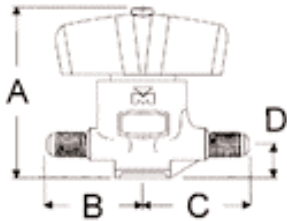

| Part No. | Size | A<br>Open | B       | C       | D     | Wt./Ea. |
|----------|------|-----------|---------|---------|-------|---------|
| A 14833  | 1/4  | 2-11/16   | 1-5/16  | 1-3/8   | 5/8   | .75     |
| A 14835  | 3/8  | 2-11/16   | 1-3/8   | 1-27/64 | 5/8   | .76     |
| A 14836  | 1/2  | 3-15/32   | 1-5/8   | 1-27/32 | 27/32 | 1.25    |
| A 14837  | 5/8  | 3-15/32   | 1-11/16 | 1-15/16 | 27/32 | 1.27    |

### STRAIGHT THRU - SOLDER TO SOLDER - TYPE I - CLASS II

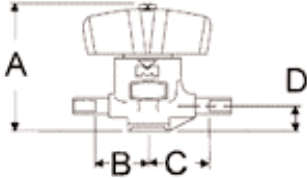

| Part No. | Size | A<br>Open | B       | C      | D     | Wt./Ea. |
|----------|------|-----------|---------|--------|-------|---------|
| A 14838  | 1/4  | 2-11/16   | 1-1/32  | 1-3/32 | 5/8   | 0.72    |
| A 14840  | 3/8  | 2-11/16   | 1-1/32  | 1-3/32 | 5/8   | 0.71    |
| A 14841  | 1/2  | 3-1/2     | 1-5/16  | 1-9/16 | 27/32 | 1.22    |
| A 14842  | 5/8  | 3-1/2     | 1-13/64 | 1-7/16 | 27/32 | 1.22    |

### EXTENDED END - SOLDER TO SOLDER - TYPE I - CLASS II

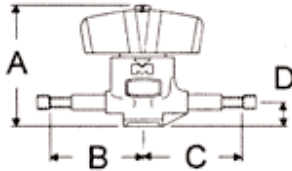

| Part No. | Size | A<br>Open | B       | C       | D     | Wt./Ea. |
|----------|------|-----------|---------|---------|-------|---------|
| A 14848  | 1/4  | 2-11/16   | 2-21/32 | 2-23/32 | 5/8   | 0.75    |
| A 14850  | 3/8  | 2-11/16   | 2-13/16 | 2-7/8   | 5/8   | 0.76    |
| A 14851  | 1/2  | 3-1/2     | 3-1/32  | 3-11/32 | 27/32 | 1.28    |
| A 14852  | 5/8  | 3-1/2     | 3-7/64  | 3-11/32 | 27/32 | 1.34    |

### ANGLE - NPTFE TO FLARE - TYPE I - CLASS I

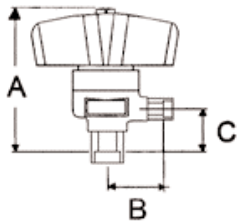

| Part No. | Size |      | A<br>Open | B       | C       | Wt./Ea. |
|----------|------|------|-----------|---------|---------|---------|
|          | O.D. | O.D. |           |         |         |         |
| A 15525  | 1/4  | 1/4  | 2-13/16   | 1-19/64 | 1-3/64  | 0.61    |
| A 15526  | 1/4  | 3/8  | 2-13/16   | 1-27/64 | 1-3/64  | 0.63    |
| A 15527  | 3/8  | 3/8  | 2-7/8     | 1-27/64 | 1-5/64  | 0.64    |
| A 15528  | 3/8  | 3/8  | 2-7/8     | 1-27/64 | 1-5/64  | 0.64    |
| A 15529  | 3/8  | 1/2  | 3-9/16    | 1-27/32 | 1-19/64 | 1.06    |
| A 15530  | 1/2  | 1/2  | 3-11/16   | 1-27/32 | 1-7/16  | 1.06    |
| A 15531  | 1/2  | 5/8  | 3-11/16   | 1-15/16 | 1-7/16  | 1.08    |

### ANGLE - SOLDER TO SOLDER - TYPE I - CLASS I

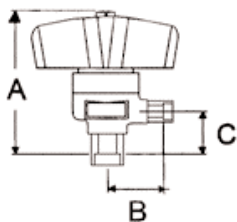

| Part No. | Size |      | A<br>Open | B      | C      | Wt./Ea. |
|----------|------|------|-----------|--------|--------|---------|
|          | O.D. | O.D. |           |        |        |         |
| A 15539  | 1/4  | 1/4  | 2 17/32   | 1 3/32 | 3/4    | 0.69    |
| A 15540  | 3/8  | 3/8  | 2 17/32   | 1 3/32 | 3/4    | 0.71    |
| A 15541  | 1/2  | 1/2  | 3 5/16    | 1 3/16 | 1 1/16 | 1.14    |
| A 15542  | 5/8  | 5/8  | 3 13/64   | 5/16   | 15/16  | 1.14    |

## COMPRESSOR VALVES & KITS

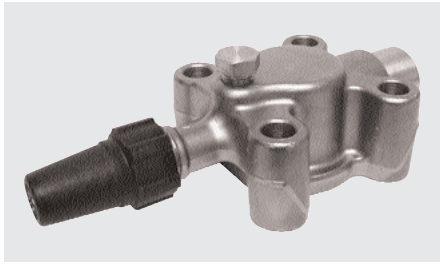

- Valve cross-reference available for all compressor manufacturers.
- Asbestos-Free valve packing material.
- Models available in forged brass and cast iron.
- Complete service kit including valve body, mounting, bolts, cap and gaskets.
- Direct original equipment replacement parts for all industry manufactured compressors.
- Manufactured to the strictest quality standards in the industry.
- Valve openings designed for maximum flow and minimum pressure drop.
- Compatible with all new refrigerant and oils
- 700 psig maximum working pressure, 3500 psig burst pressure
- Wide operating temp range from -40°F to 300°F
- Special flanges and adapters available upon request.
- All valves 100% tested.
- Recognized under component program of Underwriters Laboratories for use in the USA and Canada.

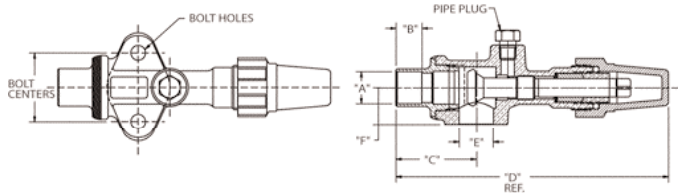

### STRAIGHT PORT-SOLDER TYPE-PLASTIC CAP

| Valve   | Kit     | A     | B     | C       | D      | E     | F   | Bolt<br>Centers | Dia<br>Bolt<br>Holes | Pipe<br>Plug<br>Size | Flange<br>Bolt<br>Centers | Flange<br>Thickness | Valve<br>Wt. | Kit<br>Wt. |
|---------|---------|-------|-------|---------|--------|-------|-----|-----------------|----------------------|----------------------|---------------------------|---------------------|--------------|------------|
| A 16310 | A 17517 | 3/4   | 5/8   | 1-29/32 | 6-9/16 | 13/16 | 7/8 | 1-5/8           | 11/32                | 1/8                  |                           | 1-21/64             | 1.64         | 1.69       |
| A 16311 | A 17515 | 7/8   | 3/4   | 1-31/32 | 6-9/16 | 13/16 | 7/8 | 1-5/8           | 11/32                | 1/8                  |                           | 1-21/64             | 1.63         | 1.67       |
| A 16317 | A 17528 | 7/8   | 3/4   | 1-31/32 | 6-1/2  | 13/16 | 7/8 | 1-5/8           | 11/32                | 1/8                  |                           | 1-21/64             | 1.63         | 1.68       |
| B 32197 | A 17529 | 7/8   | 3/4   | 1-31/32 | 6-9/16 | 13/16 | 7/8 | 1-3/4           | 11/32                | 1/8                  |                           | 1-21/64             | 1.42         | 1.69       |
| A 15500 |         | 1-1/8 | 29/32 | 2-1/16  | 6-9/16 | 13/16 | 7/8 | 1-5/8           | 11/32                | 1/8                  |                           | 1-21/64             | 1.66         |            |
| A 16312 | A 17516 | 1-1/8 | 29/32 | 2-1/16  | 6-9/16 | 13/16 | 7/8 | 1-5/8           | 11/32                | 1/8                  |                           | 1-21/64             | 1.66         | 1.71       |
| B 33367 | A 17530 | 1-1/8 | 29/32 | 2-17/64 | 6-9/16 | 1-1/8 | 7/8 | 1-3/4           | 11/32                | 1/4                  |                           | 1-21/64             |              |            |

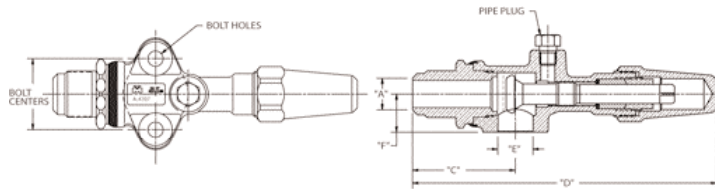

### STRAIGHT PORT-45° FLARE TYPE-PLASTIC CAP

| Valve   | Kit | A   | B | C     | D | E     | F   | Bolt<br>Centers | Dia<br>Bolt<br>Holes | Pipe<br>Plug<br>Size | Flange<br>Bolt<br>Centers | Flange<br>Thickness | Valve<br>Wt. | Kit<br>Wt. |
|---------|-----|-----|---|-------|---|-------|-----|-----------------|----------------------|----------------------|---------------------------|---------------------|--------------|------------|
| A 13166 |     | 3/4 |   | 2-3/8 | 7 | 13/16 | 7/8 | 1-5/8           | 11/32                | 1/8                  |                           | 1-1/4               | 1.78         |            |

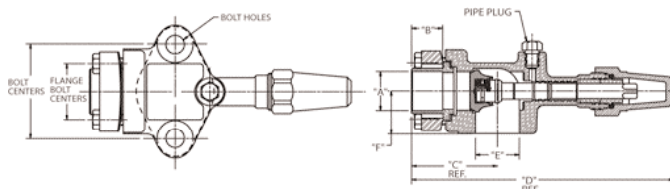

### FLANGE UNION-SOLDER TYPE-PLASTIC CAP

| Valve   | Kit     | A     | B     | C       | D       | E     | F     | Bolt<br>Centers | Dia<br>Bolt<br>Holes | Pipe<br>Plug<br>Size | Flange<br>Bolt<br>Centers | Flange<br>Thickness | Valve<br>Wt. | Kit<br>Wt. |
|---------|---------|-------|-------|---------|---------|-------|-------|-----------------|----------------------|----------------------|---------------------------|---------------------|--------------|------------|
| A 16313 |         | 3/4   | 5/8   | 2-5/16  | 7-11/32 | 1-1/4 | 1-1/4 | 2-3/4           | 17/32                | 1/8                  | 1-5/8                     | 1                   | 3.93         |            |
| A 16314 | A 17527 | 7/8   | 3/4   | 2-5/16  | 7-11/32 | 1-1/4 | 1-1/4 | 2-3/4           | 17/32                | 1/8                  | 1-5/8                     | 1                   | 3.90         | 4.05       |
| A 16315 | A 17525 | 1-1/8 | 29/32 | 2-15/32 | 7-1/2   | 1-1/4 | 1-1/4 | 2-3/4           | 17/32                | 1/8                  | 1-5/8                     | 1                   | 3.88         | 4.03       |
| A 16316 | A 17526 | 1-3/8 | 31/32 | 2-15/32 | 7-1/2   | 1-1/4 | 1-1/4 | 2-3/4           | 17/32                | 1/8                  | 1-5/8                     | 1                   | 3.66         | 3.80       |

## COMPRESSOR VALVES & KITS

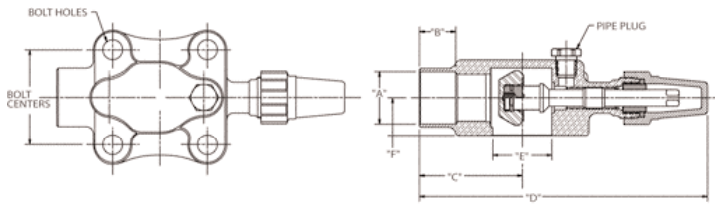

DOUBLE PORT-SOLDER TYPE-STEEL CAP

| Valve   | Kit     | A   | B    | C       | D       | E    | F   | Bolt Centers | Dia Bolt Holes | Pipe Plug Size | Flange Bolt Centers | Flange Thickness | Valve Wt. | Kit Wt. |
|---------|---------|-----|------|---------|---------|------|-----|--------------|----------------|----------------|---------------------|------------------|-----------|---------|
| A 16307 | A 17510 | 3/8 | 5/16 | 1-1/4   | 4-5/64  | 9/16 | 5/8 | 1-5/8        | 11/32          | 1/8            |                     | 7/8              | 0.69      | 0.73    |
| A 16308 | A 17511 | 1/2 | 3/8  | 1-13/32 | 4-13/64 | 9/16 | 5/8 | 1-5/8        | 11/32          | 1/8            |                     | 7/8              | 0.86      | 0.89    |
| A 16309 | A 17512 | 5/8 | 1/2  | 1-1/2   | 4-1/2   | 9/16 | 5/8 | 1-5/8        | 11/32          | 1/8            |                     | 7/8              | 0.88      | 0.92    |
| A 16309 | A 17531 | 5/8 | 1/2  | 1-1/2   | 4-1/2   | 9/16 | 5/8 | 1-5/8        | 11/32          | 1/8            |                     | 7/8              | 0.88      | 0.92    |

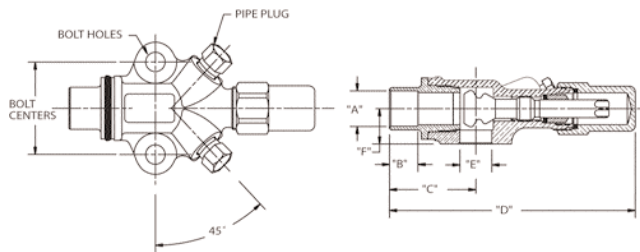

DOUBLE PORT-45° FLARE TYPE-STEEL CAP

| Valve   | Kit     | A   | B | C     | D       | E    | F   | Bolt Centers | Dia Bolt Holes | Pipe Plug Size | Flange Bolt Centers | Flange Thickness | Valve Wt. | Kit Wt. |
|---------|---------|-----|---|-------|---------|------|-----|--------------|----------------|----------------|---------------------|------------------|-----------|---------|
| A 16302 | A 17518 | 3/8 |   | 1-3/4 | 4-7/16  | 9/16 | 5/8 | 1-5/8        | 11/32          | 1/8            |                     | 7/8              | 1.20      | 1.24    |
| A 16303 | A 17519 | 1/2 |   | 1-7/8 | 4-11/16 | 9/16 | 5/8 | 1-5/8        | 11/32          | 1/8            |                     | 7/8              | 1.17      | 1.20    |
| A 16304 | A 17520 | 5/8 |   | 2     | 4-13/16 | 9/16 | 5/8 | 1-5/8        | 11/32          | 1/8            |                     | 7/8              | 1.23      | 1.27    |

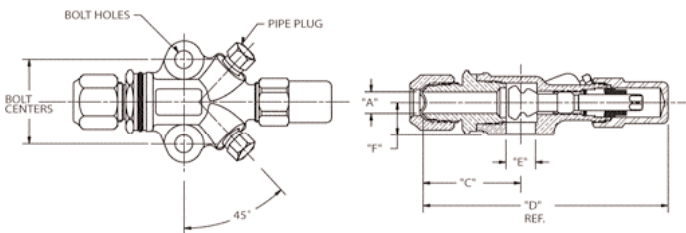

4-BOLT MOUNTING STYLE-SOLDER TYPE-FLAT GASKET SURFACE-PLASTIC CAP

| Valve   | Kit     | A     | B      | C       | D     | E      | F      | Bolt Centers | Dia Bolt Holes | Pipe Plug Size | Flange Bolt Centers | Flange Thickness | Valve Wt. | Kit Wt. |
|---------|---------|-------|--------|---------|-------|--------|--------|--------------|----------------|----------------|---------------------|------------------|-----------|---------|
| B 32087 | A 17532 | 1-1/8 | 29/32  | 2-23/32 | 7-5/8 | 1-9/16 | 1      | 2-1/2        | 17/32          | 1/4            |                     |                  | 3.88      | 4.03    |
| B 32088 | A 17533 | 1-3/8 | 31/32  | 2-23/32 | 7-5/8 | 1-9/16 | 1      | 2-1/2        | 17/32          | 1/4            |                     |                  | 3.66      | 3.80    |
| B 32930 | A 17534 | 1-5/8 | 1-3/32 | 2-7/8   | 7-5/8 | 1-9/16 | 1-1/32 | 2-1/2        | 17/32          | 1/4            |                     |                  | 3.90      | 4.05    |

## COMPRESSOR VALVES &amp; KITS

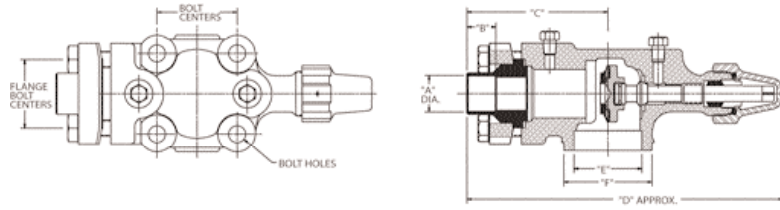

4-BOLT-CAST IRON COMPRESSOR VALVES

| Valve   | Kit     | A     | B       | C       | D        | E       | F       | Bolt<br>Centers | Dia<br>Bolt<br>Holes | Pipe<br>Plug<br>Size | Flange<br>Bolt<br>Centers | Seal<br>Cap<br>Material | Valve<br>Wt. | Kit<br>Wt. |
|---------|---------|-------|---------|---------|----------|---------|---------|-----------------|----------------------|----------------------|---------------------------|-------------------------|--------------|------------|
| B 33813 |         | 1-3/8 | 31/32   | 4-13/32 | 9-29/32  | 2-1/8   | 2-3/4   | 2-1/2           | 17/32                | 1/4                  | 2-1/8                     | Cast Iron               | 9.43         |            |
| A 15246 |         | 1-5/8 | 1-3/32  | 3-61/64 | 9-15/32  | 2-1/8   | 2-3/4   | 2-1/2           | 17/32                | 1/4                  | 2-1/8                     | Valox                   | 9.37         |            |
| A 16321 | A 17513 | 1-5/8 | 1-3/32  | 4-19/32 | 10 -3/64 | 2-1/8   | 2-3/4   | 2-1/2           | 17/32                | 1/4                  | 2-1/8                     | Valox                   | 8.72         | 8.92       |
| A 16367 | A 17524 | 1-5/8 | 1-3/32  | 5-1/4   | 11-29/32 | 2-1/8   | 3-7/32  | 3-1/16          | 11/16                | 1/4                  | 3-1/16                    | Valox                   | 18.20        | 18.61      |
| A 16496 |         | 1-5/8 | 1-3/32  | 3-61/64 | 9-15/32  | 2-1/8   | 2-3/4   | 2-1/2           | 17/32                | 1/4                  | 2-1/8                     | Valox                   | 8.74         |            |
| B 32337 |         | 1-5/8 | 1-3/32  | 3-61/64 | 9-15/32  | 2-1/8   | 2-3/4   | 2-1/2           | 17/32                | 1/4                  | 2-1/8                     | Valox                   | 9.07         |            |
| B 33770 |         | 1-5/8 | 1-3/32  | 4-19/32 | 10-1/64  | 2-1/8   | 2-3/4   | 2-1/2           | 17/32                | 1/4                  | 2-1/8                     | Cast Iron               | 8.46         |            |
| B 33842 |         | 1-5/8 | 1-3/32  | 5-1/4   | 11-29/32 | 2-1/8   | 3-7/32  | 3-1/16          | 11/16                | 1/4                  | 3-1/16                    | Cast Iron               | 18.97        |            |
| B 33784 |         | 2     | 1-9/32  | 5-1/64  | 11-55/64 | 2-1/8   | 3-7/32  | 3-1/16          | 11/16                | 1/4                  | 3-1/16                    | Valox                   | 16.42        |            |
| A 15586 | A 17535 | 2-1/8 | 1-5/16  | 5-1/16  | 11-61/64 | 2-1/8   | 3-7/32  | 3-1/16          | 11/16                | 1/4                  | 3-1/16                    | Valox                   | 18.28        | 6.69       |
| A 16324 | A 17523 | 2-1/8 | 1-5/16  | 5-1/16  | 11-61/64 | 2-1/8   | 3-7/32  | 3-1/16          | 11/16                | 1/4                  | 3-1/16                    | Valox                   | 18.28        | 18.69      |
| A 16493 |         | 2-1/8 | 1-5/16  | 5-1/16  | 11-61/64 | 2-1/8   | 3-7/32  | 3-1/16          | 11/16                | 1/4                  | 3-1/16                    | Valox                   | 17.71        |            |
| B 33572 |         | 2-1/8 | 1-5/16  | 5-1/16  | 11-61/64 | 2-1/8   | 3-7/32  | 3-1/16          | 11/16                | 1/4                  | 3-1/16                    | Valox                   | 17.49        |            |
| B 33771 | B 34325 | 2-1/8 | 1-5/16  | 5-1/16  | 11-7/8   | 2-1/8   | 3-7/32  | 3-1/16          | 11/16                | 1/4                  | 3-1/16                    | Cast Iron               | 16.05        | 19.54      |
| B 34429 |         | 2-1/8 | 1-5/16  | 5-1/16  | 11-61/64 | 2-1/8   | 3-7/32  | 3-1/16          | 11/16                | 1/4                  | 3-1/16                    | Valox                   | 17.28        |            |
| B 34671 |         | 2-1/8 | 1-5/16  | 5-1/16  | 11-61/64 | 2-33/64 | 3-7/32  | 3-1/16          | 11/16                | 1/4                  | 3-1/16                    | Valox                   | 17.28        |            |
| A 15587 |         | 2-5/8 | 1-9/32  | 5-1/64  | 12-1/16  | 2-1/8   | 3-7/32  | 3-1/16          | 11/16                | 1/4                  | 3-1/16                    | Valox                   | 20.30        |            |
| A 16366 | A 17522 | 2-5/8 | 1-15/32 | 6-1/2   | 15-1/8   | 3-11/32 | 4-5/32  | 3-7/8           | 11/16                | 1/4                  | 3-7/8                     | Cast Iron               | 33.18        | 33.73      |
| B 33568 |         | 2-5/8 | 1-9/32  | 5-1/64  | 11-29/32 | 2-1/8   | 3-7/32  | 3-1/16          | 11/16                | 1/4                  | 3-1/16                    | Valox                   | 20.23        |            |
| B 34314 |         | 2-5/8 | 1-15/32 | 6-1/2   | 15-1/8   | 3-11/32 | 4-5/32  | 3-7/8           | 11/16                | 1/4                  | 3-7/8                     | Cast Iron               | 30.80        |            |
| B 34582 |         | 2-5/8 | 1-17/64 | 5-3/64  | 11-29/32 | 2-1/8   | 3-7/32  | 3-1/16          | 11/16                | 1/4                  | 3-1/16                    | Valox                   |              |            |
| B 34661 |         | 2-5/8 | 1-15/32 | 6-1/2   | 15-1/8   | 3-11/32 | 4-5/32  | 3-7/8           | 11/16                | 1/4                  | 3-7/8                     | Cast Iron               | 30.80        |            |
| A 15588 |         | 3-1/8 | 1-7/32  | 5-15/16 | 14-39/64 | 3-11/32 | 4-5/32  | 3-7/8           | 11/16                | 1/4                  | 3-7/8                     | Cast Iron               | 33.22        |            |
| A 16365 | A 17521 | 3-1/8 | 1-7/32  | 5-15/16 | 14-39/64 | 3-11/32 | 4-5/32  | 3-7/8           | 11/16                | 1/4                  | 3-7/8                     | Cast Iron               | 33.22        | 33.77      |
| B 33569 |         | 3-1/8 | 1-7/32  | 5-15/16 | 14-39/64 | 3-11/32 | 4-5/32  | 3-7/8           | 11/16                | 1/4                  | 3-7/8                     | Cast Iron               | 32.38        |            |
| A 17496 |         | 3-5/8 | 2-1/16  | 7       | 16-19/64 | 3-7/8   | 4-35/64 | 4-1/4           | 11/16                | 1/4                  | 4-1/4                     | Cast Iron               | 34.01        |            |
| B 33788 |         | 3-5/8 | 2-1/16  | 7       | 16-19/64 | 3-7/8   | 4-35/64 | 4-1/4           | 11/16                | 1/4                  | 4-1/4                     | Cast Iron               | 34.01        |            |
| B 34315 |         | 3-5/8 | 2-1/16  | 7       | 16-19/64 | 3-7/8   | 4-35/64 | 4-1/4           | 11/16                | 1/4                  | 4-1/4                     | Cast Iron               | 40.51        |            |
| B 34670 |         | 3-5/8 | 2-1/16  | 7       | 16-19/64 | 3-7/8   | 4-9/64  | 4-1/4           | 11/16                | 1/4                  | 4-1/4                     | Cast Iron               | 40.51        |            |
| A 15589 |         | 4-1/8 | 1-31/32 | 7-7/32  | 17-1/2   | 4-3/8   | 5-1/8   | 4-13/16         | 13/16                | 1/4                  | 4-13/16                   | Cast Iron               | 49.80        |            |

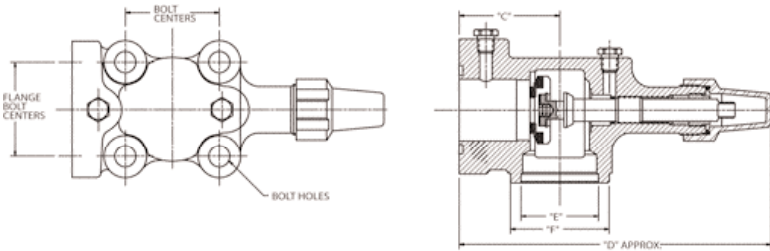

4-BOLT-CAST IRON COMPRESSOR VALVES WITHOUT FLANGES

| Valve     | Kit | A | B | C       | D         | E       | F       | Bolt<br>Centers | Dia<br>Bolt<br>Holes | Pipe<br>Plug<br>Size | Flange<br>Bolt<br>Centers | Seal<br>Cap<br>Material | Valve<br>Wt. | Kit<br>Wt. |
|-----------|-----|---|---|---------|-----------|---------|---------|-----------------|----------------------|----------------------|---------------------------|-------------------------|--------------|------------|
| B 33793   |     |   |   | 3-9/32  | 10-11/164 | 2-17/32 | 3-7/32  | 3-1/16          | 11/16                | 1/4                  | 3-1/16                    | Valox                   | 12.58        |            |
| B 33794   |     |   |   | 3-25/32 | 12-7/16   | 3-11/32 | 4-5/32  | 3-7/8           | 11/16                | 1/4                  | 3-7/8                     | Cast Iron               | 22.05        |            |
| B 34183   |     |   |   | 2-11/16 | 8-3/32    | 2-1/8   | 2-3/4   | 2-1/2           | 17/32                | 1/4                  | 2-1/8                     | Valox                   | 6.91         |            |
| B 34497   |     |   |   | 3-63/64 | 13-1/4    | 3-7/8   | 4-35/64 | 4-1/4           | 11/16                | 1/4                  | 4-1/4                     | Cast Iron               | 34.00        |            |
| B 34498   |     |   |   | 3-9/32  | 10-1/8    | 2-17/32 | 3-7/32  | 3-1/16          | 11/16                | 1/4                  | 3-1/16                    | Valox                   | 17.28        |            |
| B 34715   |     |   |   | 3-25/32 | 13        | 3-11/32 | 4-5/32  | 3-7/8           | 11/16                | 1/4                  | 3-7/8                     | Steel                   | 22.05        |            |
| B 34761   |     |   |   | 3-9/32  | 10-11/64  | 2-17/32 | 3-1/32  | 3-1/16          | 11/16                | 1/4                  | 3-1/16                    | Valox                   | 13.00        |            |
| B 34929** |     |   |   | 4-9/16  | 14-53/64  | 4-3/8   | 5-1/8   | 4-13/16         | 13/16                | 1/4                  | 4-13/16                   | Cast Iron               | 37.00        |            |
| B 35049   |     |   |   | 3-9/32  | 10-1/8    | 2-17/32 | 3-7/32  | 3-1/16          | 11/16                | 1/4                  | 3-1/16                    | Valox                   | 12.97        |            |

## COMPRESSOR VALVES & KITS

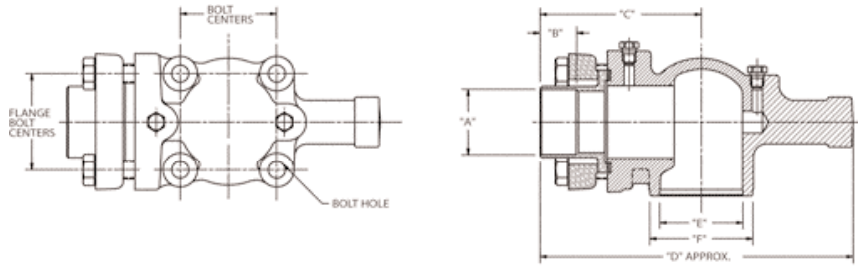

4-BOLT-CAST IRON FLANGES

| Valve    | Kit | A     | B       | C     | D        | E       | F      | Bolt Centers | Dia Bolt Holes | Pipe Plug Size | Flange Bolt Centers | Seal Cap Material | Valve Wt. | Kit Wt. |
|----------|-----|-------|---------|-------|----------|---------|--------|--------------|----------------|----------------|---------------------|-------------------|-----------|---------|
| B 34987* |     | 2-5/8 | 1-15/32 | 6-1/2 | 12-35/64 | 3-11/32 | 4-5/32 | 3-7/8        | 11/16          | 1/4            | 3 7/8               |                   | 28.50     |         |
| B 33794  |     | 3-5/8 | 2-1/16  | 7     | 13-39/64 | 3-7/8   | 4-9/16 | 4-1/4        | 11/16          | 1/4            | 4 1/4               |                   | 33.50     |         |

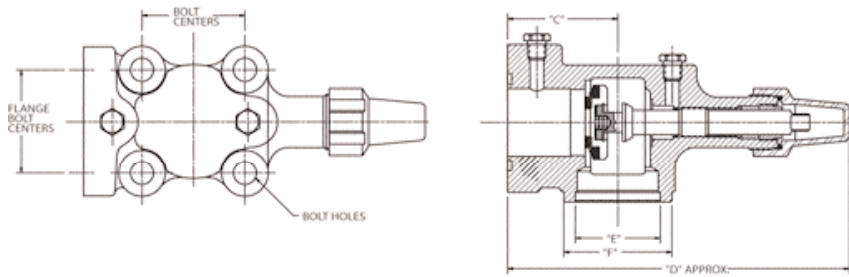

AMMONIA VALVES

| Valve   | Kit | A | B | C       | D        | E       | F      | Bolt Centers | Dia Bolt Holes | Pipe Plug Size | Flange Bolt Centers | Seal Cap Material | Valve Wt. | Kit Wt. |
|---------|-----|---|---|---------|----------|---------|--------|--------------|----------------|----------------|---------------------|-------------------|-----------|---------|
| B 35308 |     |   |   | 3-9/32  | 10-11/64 | 2-17/32 | 3-7/32 | 3-1/16       | 11/16          |                | 3-1/16              | Valox             | 13.02     |         |
| B 35358 |     |   |   | 3-25/32 | 12-7/16  | 3-11/32 | 4-5/32 | 3-7/8        | 11/16          |                | 3-1/16              | Cast Iron         | 22.05     |         |

## CHECK VALVES

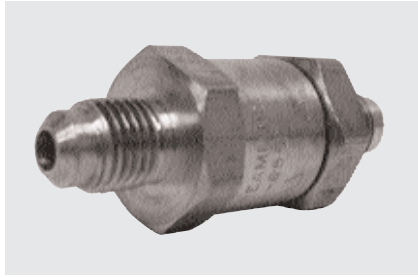

- Recognized under component program of Underwriters Laboratories for use in the USA and Canada
- Maximum working pressure is 500 psig.
- maximum temperature rating at +200°F
- Soft Neoprene seat provides positive seal against reverse flow.
- Four spacer tabs maintain washer/seat alignment and guide the seat disc for smooth operation.
- Stainless steel spring allows valve to operate (close) in any position.
- Buna N Gasket provides permanent seal.
- Brass body machined from drawn brass rod is designed to offer minimum restriction to flow.

## FLARE TO FLARE

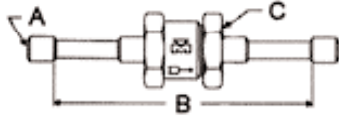
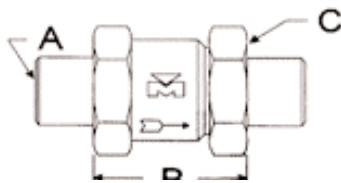
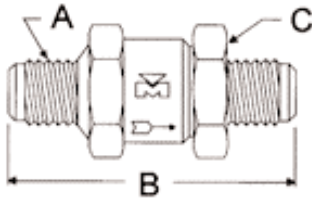

| Part No. | Size Flare |         |           | Wt./Ea. |
|----------|------------|---------|-----------|---------|
|          | A          | B       | C         |         |
| A 15620  | 1/4        | 2-3/16  | 13/16 Hex | .14     |
| A 15621  | 3/8        | 2-13/32 | 13/16 Hex | .18     |
| A 15622  | 1/2        | 3       | 1-1/4 Oct | .44     |
| A 15623  | 5/8        | 3-5/16  | 1-1/4 Oct | .52     |

## SOLDER TO SOLDER-SHIPPED LOOSELY ASSEMBLED

| Part No. | Size O.D. |        |           | Wt./Ea. |
|----------|-----------|--------|-----------|---------|
|          | A         | B      | C         |         |
| A 15628  | 1/4       | 1-3/16 | 13/16 Hex | .13     |
| A 15629  | 3/8       | 1-5/32 | 13/16 Hex | .13     |
| A 15630  | 1/2       | 1-7/16 | 1-1/4 Oct | .36     |
| A 15631  | 5/8       | 1-7/16 | 1-1/4 Oct | .37     |

## SOLDER TO SOLDER-EXTENDED ENDS

| Part No. | Size O.D. |         |          | Wt./Ea. |
|----------|-----------|---------|----------|---------|
|          | A         | B       | C        |         |
| A 15632  | 1/4       | 4-7/16  | 13/16Hex | .17     |
| A 15633  | 3/8       | 4-9/16  | 13/16Hex | .17     |
| A 15634  | 1/2       | 4-29/32 | 1-1/4Oct | .42     |
| A 15635  | 5/8       | 5-13/64 | 1-1/4Oct | .48     |

## FOUR-BOLT CHECK VALVES

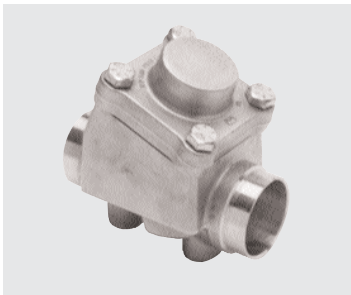

- 4-bolt flange allows easy disassembly and assembly for brazing or internal component changes.
- Forged brass body ensures the product exceeds the most stringent quality standards in the industry.
- Horizontal or vertical installation.
- "Y" type design provides minimal pressure drop and increased flow capacity.
- Non-asbestos gasket material and O-Ring seal ensures seal integrity and is compatible with new refrigerants and oils.
- Heat-stabilized P.F.T.E seat provides positive seal across wide temperature ranges.
- Working temperature range from -40°F to 300°F, and maximum working pressure 500 psig.
- Back-pressure shutoff at low pressure differentials.
- Special springs available for various differential applications.
- All valves 100% tested and compatible with all fluorinated refrigerants.
- Recognized under the component program of Underwriters Laboratories for use in the USA and Canada.

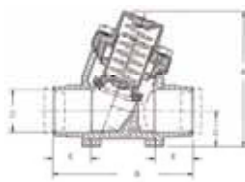

| Size  | Part No. | A       | B       | C       | D     | E      | Cv    | Weight | Replacement |              | Replacement Components |         |
|-------|----------|---------|---------|---------|-------|--------|-------|--------|-------------|--------------|------------------------|---------|
|       |          |         |         |         |       |        |       |        | Kit No.**   | 10 lb Spring | Alternative Spring     | Gasket  |
| 7/8   | B 34235  | 3-19/32 | 3-11/16 | 3-1/32  | 7/8   | 15/16  | 5.05  | 2.46   | A 17986     | P 35656      | P 35859, 30 lb         | P 35708 |
| 1-1/8 | B 34236  | 3-19/32 | 3-11/16 | 3-1/32  | 1-1/8 | 1      | 6.7   | 2.31   | A 17986     | P 35657      | *                      | P 35708 |
| 1-3/8 | B 34237  | 4-9/16  | 4-3/4   | 1-5/16  | 1-3/8 | 1-1/16 | 8.71  | 5.42   | A 17987     | P 35657      | P 36305, 20 lb         | P 35691 |
| 1-5/8 | B 34238  | 4-9/16  | 4-3/4   | 1-5/16  | 1-5/8 | 1-1/16 | 10.06 | 5.04   | A 17987     | P 35657      | *                      | P 35691 |
| 2-1/8 | B 34239  | 5-7/8   | 6-3/8   | 1-11/16 | 2-1/8 | 1-1/2  | 36    | 12.6   | A 17988     | P 36544      | *                      | P 35721 |
| 2-5/8 | B 34240  | 8       | 8-7/8   | 2       | 2-5/8 | 1-7/8  | 70    | *      | A 18050     | *            | *                      | P 36041 |
| 3-1/8 | B 34241  | 8       | 8-7/8   | 2       | 3-1/8 | 1-7/8  | *     | *      | A 18050     | *            | *                      | P 36041 |

\* Consult factory

\*\* Replacement kit includes seat holder subassembly, cover gasket and 2 lb. spring

## CMV SERIES MAGNETIC CHECK VALVES



- Near zero leak rate.
- Built-in 30 mesh stainless steel screen.
- Internal components installed with DuraForm Technology.
- Mechanically formed solder cup stops for ease of installation.
- Flexible for installation in a vertical or horizontal position.
- Compatible with all CFC, HCFC and HFC refrigerants.
- All valves are UL/cUL/CE recognized.
- Wide operating temp range from -400°F to 300° F

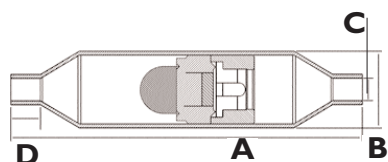

| Part Number | CMV Series | Connection Size (in) | A (in) | B (in) | D Min (in) | MWP (psi) | Cross Reference                     |
|-------------|------------|----------------------|--------|--------|------------|-----------|-------------------------------------|
|             |            |                      |        |        |            |           | Leakage Rate (in <sup>3</sup> /min) |
| A 17934     | CMV-4S     | 1/4"                 | 4      | 7/8    | .31        | 800       | 0.15                                |
| A 17935     | CMV-6S     | 3/8"                 | 4      | 7/8    | .31        | 800       | 0.15                                |
| A 17936     | CMV-8S     | 1/2"                 | 5-1/8  | 1-1/8  | .38        | 700       | .034                                |
| A 17937     | CMV-10S    | 5/8"                 | 5-1/8  | 1-1/8  | .50        | 700       | .034                                |
| A 17938     | CMV-12S    | 3/4"                 | 7      | 1-5/8  | .62        | 700       | .074                                |
| A 17939     | CMV-14S    | 7/8"                 | 7      | 1-5/8  | .75        | 700       | .074                                |
| A 17940     | CMV-18S    | 1-1/8"               | 8-3/8  | 2-1/8  | .91        | 700       | .122                                |
| A 17941     | CMV-22S    | 1-3/8"               | 9-3/8  | 2-5/8  | .97        | 700       | .172                                |
| A 17942     | CMV-26S    | 1-5/8"               | 10-1/2 | 3-1/8  | 1.09       | 700       | .272                                |
| A 17943     | CMV-34S    | 2-1/8"               | 12     | 3-5/8  | 1.34       | 700       | .386                                |
| A 17944     | CMV-42S    | 2-5/8"               | 13     | 4-1/8  | 1.47       | 700       | .512                                |
| A 17981     | CMV-50S    | 3-1/8"               | 13     | 4-1/8  | 1.66       | 650       | .512                                |

## HI-FLOW RESIDENTIAL CHECK VALVES

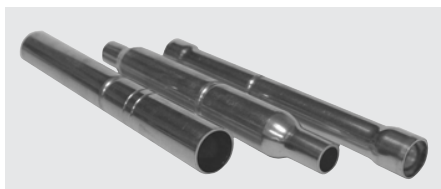

- Design implements a piston stopper, providing a more positive seal, reducing the leak rate compared to industry standards
- Internal components constructed of brass and stainless steel.
- Wide operating temperature range of -40°F to 300°F, and working pressures up to 700 psig.
- Flexible design allows specialty connection combinations, assembly lengths and filtration mesh sizes.
- Compatible with all CFC, HCFC and HFC refrigerants and oils.
- Slotted Cage versions available for greater flow capacity.

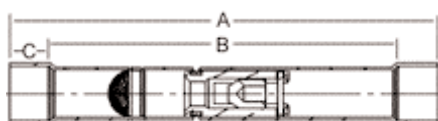
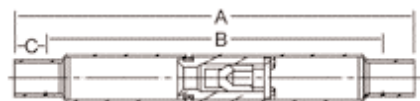
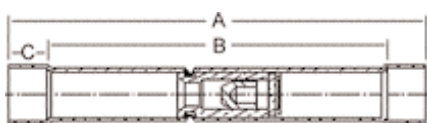

### 3/8" BODY WITH SOLID CAGE

| Part Number | Connection Type | A    | B    | C   |
|-------------|-----------------|------|------|-----|
| A 17992     | 1/4" F x 1/4" F | 3.96 | 3.34 | .31 |
| A 17993     | 3/8" M x 1/8" M | 3.96 | 3.34 | .31 |
| A 17994     | 3/8" M x 3/8" F | 3.96 | 3.34 | .31 |

### 1/2" BODY WITH SLOTTED CAGE

| Part Number | Connection Type | A    | B    | C   |
|-------------|-----------------|------|------|-----|
| A 17995     | 1/4" F x 1/4" F | 4.00 | 3.38 | .31 |
| A 17996     | 3/8" F x 1/8" F | 4.00 | 3.38 | .31 |
| A 17997     | 1/2" F x 1/2" F | 4.00 | -    | -   |
| A 17998     | 1/2" F x 1/2" F | 4.00 | 3.24 | .38 |
| A 17999     | 1/2" F x 1/2" M | 4.65 | 4.27 | .38 |

### 1/2" BODY WITH SLOTTED CAGE AND SCREEN

| Part Number | Connection Type | A    | B    | C   |
|-------------|-----------------|------|------|-----|
| A 18006     | 1/4" F x 1/4" F | 4.00 | 3.38 | .31 |
| A 18007     | 3/8" F x 1/8" F | 4.00 | 3.38 | .31 |
| A 18008     | 1/2" M x 1/2" M | 4.00 | -    | -   |
| A 18009     | 1/2" F x 1/2" F | 4.00 | 3.21 | .38 |
| A 18010     | 1/2" F x 1/2" M | 4.65 | 4.27 | .38 |



## SCREW BONNET CHECK VALVES



- Design features easy removal and reassembly of internal components.
- Designed to provide minimal pressure drop and increased flow capacity.
- Bonnet gasket is made from neoprene o-ring, offering a reusable seal.
- Special seal technology provides positive shut off with low back pressure.
- Maximum working pressure is 700 psig.
- Lightweight spring requires minimum opening force.
- Available with copper tube extensions.
- Compatible with all CFC, HCFC and HFC refrigerants.
- Recognized under the component program of Underwriters Laboratories for use in the USA and Canada.
- Working temperature range from -40°F to 300°F

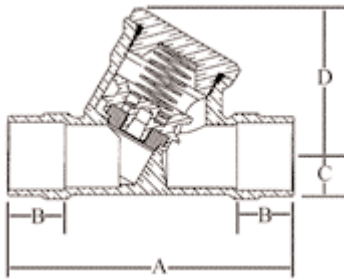

| Part No.             | Size | A       | B     | C    | D     | Cv | Replacement Springs |         |
|----------------------|------|---------|-------|------|-------|----|---------------------|---------|
|                      |      |         |       |      |       |    | 5 lbs.              | 10 lbs. |
| <b>ODS X ODS</b>     |      |         |       |      |       |    |                     |         |
| A 17953              | 1/4  | 3       | 5/16  | 7/16 | 1-5/8 | *  | P 36542             | P 36543 |
| A 17954              | 3/8  | 3       | 7/16  | 7/16 | 1-5/8 | *  | P 36542             | P 36543 |
| A 17955              | 1/2  | 3       | 9/16  | 7/16 | 1-5/8 | *  | P 36542             | P 36543 |
| A 17956              | 5/8  | 3-5/16  | 11/16 | 7/16 | 1-5/8 | *  | P 36542             | P 36543 |
| A 17957              | 3/4  | 3-3/4   | 3/4   | 5/8  | 2     | *  | *                   | *       |
| A 17958              | 7/8  | 3-3/4   | 3/4   | 5/8  | 2     | *  | *                   | *       |
| B 34873              | 5/8  | 3-3/4   | 3/4   | 5/8  | 2     | *  | *                   | *       |
| <b>Extended Ends</b> |      |         |       |      |       |    |                     |         |
| AT17953              | 1/4  | 6-1/4   | 5/16  | 7/16 | 1-5/8 | *  | P 36542             | P 36543 |
| AT17954              | 3/8  | 6-1/8   | 3/8   | 7/16 | 1-5/8 | *  | P 36542             | P 36543 |
| AT17955              | 1/2  | 5-15/16 | 3/8   | 7/16 | 1-5/8 | *  | P 36542             | P 36543 |
| AT17956              | 5/8  | 6-13/16 | 1/2   | 7/16 | 1-5/8 | *  | P 36542             | P 36543 |
| AT17958              | 7/8  | 7-3/4   | 3/4   | 5/8  | 2     | *  | *                   | *       |

\* Contact Factory

Prefixed for Spring Options:

AG = Includes 5 lb. spring

AH = Includes 10 lb. spring

**Examples:**

A 17953 = 1/4 ODS x ODS w/ 2 lb. spring

AG 17953 = 1/4 ODS x ODS w/ 5 lb. spring

ATG 17953 = 1/4 ODS x ODS extended ends w/ 5 lb. spring

## RUPTURE DISC



- One piece brass construction.
- Non-fragmenting Rupture Disc.
- Dual Access Ports.
- Certified to meet ASME Code.
- Certified Category 4 product for CE (PED) Requirements.
- Pressure gauge accessory available.

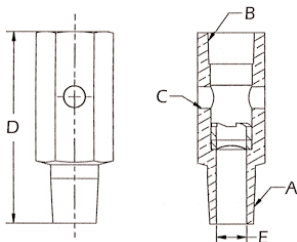

| ASME/CE<br>Valve | A<br>NPTE | B<br>NPTI | C<br>NPT | D    |      | Pressure Gauge |       |
|------------------|-----------|-----------|----------|------|------|----------------|-------|
|                  |           |           |          | (in) | (cm) | (in)           | (cm)  |
| A 17971          | 1/2       | 1/2       | 1/8      | 2.81 | 7.14 | 3.25           | 82.54 |

Prefixed for standard settings are:

AD = 235 psig.

AG = 350 psig.

AI = 425 psig.

AE = 300 psig.

AH = 400 psig.

AJ = 450 psig.

## PRESSURE RELIEF VALVES

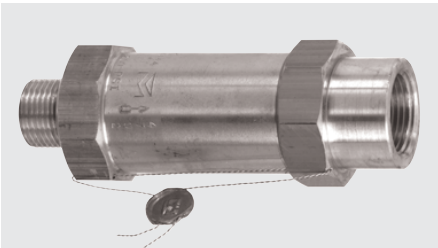

- Designed and engineered to provide high volume discharge.
- Designed to operate according to ASHRAE standard 15.
- Comply with ASME code for unfired pressure vessels.
- Discharge rates are certified by the National Board of Boiler and Pressure Vessel Inspectors.
- Quality components include brass body, "P.F.T.E clad" neoprene seat, stainless steel spring and copper gasket.
- Anti-tamper seal and locking wire

### STRAIGHT THRU-NPTFE INLET TO FLARE

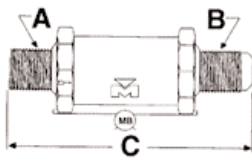

| ASME Valve | Inlet (A)<br>(in) | Outlet (B)<br>(in) | (C)     |       | Wt. Ea. |      | Discharge Table |
|------------|-------------------|--------------------|---------|-------|---------|------|-----------------|
|            |                   |                    | (in)    | (cm)  | (lb)    | (kg) |                 |
| A 15501    | 1/4               | 3/8                | 2-21/32 | 6.75  | 0.19    | 0.09 | A               |
| A 15502    | 3/8               | 3/8                | 2-13/16 | 7.14  | 0.33    | 0.15 | B               |
| A 15503    | 3/8               | 1/2                | 3       | 7.62  | 0.36    | 0.16 | B               |
| A 15504    | 1/2               | 5/8                | 4-3/16  | 10.64 | 0.84    | 0.38 | C               |
| B 33752    | 1/4               | 3/8                | 2-13/16 | 7.14  | 0.32    | 0.14 | B               |
| B 33753    | 1/4               | 1/2                | 3       | 7.62  | NA      | NA   | B               |

### ANGLE-NPTFE TO FLARE

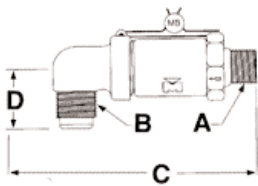

| ASME Valve | Inlet (A)<br>(in) | Outlet (B)<br>(in) | (C)    |       | (D)     |      | Wt. Ea. |      | Discharge Table |
|------------|-------------------|--------------------|--------|-------|---------|------|---------|------|-----------------|
|            |                   |                    | (in)   | (cm)  | (in)    | (cm) | (lb)    | (kg) |                 |
| B 33746    | 1/4               | 3/8                | 2-3/8  | 6.03  | 1-1/8   | 2.86 | 0.30    | 0.14 | B               |
| B 33754    | 1/4               | 1/2                | 2-7/16 | 6.19  | 1-5/16  | 3.33 | NA      | NA   | B               |
| A 15512    | 3/8               | 3/8                | 2-3/8  | 6.03  | 1-3/8   | 3.49 | 0.36    | 0.16 | B               |
| A 15513    | 3/8               | 1/2                | 2-3/8  | 6.03  | 1-11/32 | 3.41 | 0.38    | 0.17 | B               |
| A 15514    | 1/2               | 5/8                | 4-3/32 | 10.40 | 1-9/16  | 3.97 | 0.98    | 0.45 | C               |

### ATMOSPHERIC-NPTFE INLET

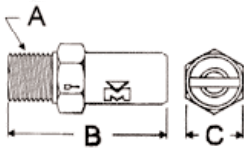

| ASME Valve | Inlet (A)<br>(in) | (B)<br>(in) | (C)  |      | Wt. Ea. |      | Discharge Table |
|------------|-------------------|-------------|------|------|---------|------|-----------------|
|            |                   |             | (in) | (cm) | (lb)    | (kg) |                 |
| A 15508    | 1/8               | 1-7/8       | 3/4  | 1.91 | 0.12    | 0.05 | A               |
| A 15509    | 1/4               | 2           | 3/4  | 1.91 | 0.13    | 0.06 | A               |
| A 17430    | 3/8               | 2-1/8       | 1    | 2.54 | 0.24    | 0.11 | B               |
| B 33755    | 1/4               | 2-1/8       | 1    | 2.54 | NA      | NA   | B               |

### STRAIGHT THRU-NPTFE INLET TO NPTFI OUTLET

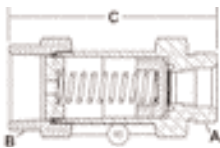

| ASME Valve | Inlet (A)<br>(in) | (B)<br>(in) | (C)    |       | Wt. Ea. |      | Discharge Table |
|------------|-------------------|-------------|--------|-------|---------|------|-----------------|
|            |                   |             | (in)   | (cm)  | (lb)    | (kg) |                 |
| A 17840    | 1                 | 1           | 4-9/16 | 11.59 | 1.95    | 0.88 | E               |
| A 17834    | 1-1/4             | 1-1/4       | 5      | 12.70 | 2.00    | 0.91 | F               |
| A 15506    | 3/4               | 3/4         | 5      | 12.70 | 1.49    | 0.68 | D               |

### STRAIGHT THRU-STRAIGHT THREAD INLET TO NPTFI OUTLET

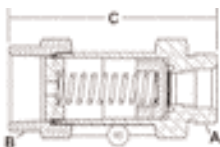

| ASME Valve | Inlet (A)<br>(in) | (B)<br>(in) | (C)   |       | Wt. Ea. |      | Discharge Table |
|------------|-------------------|-------------|-------|-------|---------|------|-----------------|
|            |                   |             | (in)  | (cm)  | (lb)    | (kg) |                 |
| B 34444    | 7/8 -14 UNF 2A    | 3/4         | 5     | 12.70 | 1.53    | 0.69 | D               |
| B 34519    | 1-5/16 -12UNF2A   | 1           | 4 3/8 | 11.11 | 1.37    | 0.62 | E               |
| B 34580    | 1-5/8 -12UNF-2A   | 1-1/4       | 5     | 12.70 | 2.00    | 0.91 | F               |

Prefixes for standard settings are:

AD/BD = 235 psig.    AH/BH = 400 psig.  
 AE/BE = 300 psig.    AI/BI = 425 psig.  
 AG/BG = 350 psig.    AJ/BJ = 450 psig.

For valves furnished at non-standard settings, use part numbers as listed in specification charts and indicate exact pressure setting.

## RELIEFMASTER™ CHANGE-OVER MANIFOLD

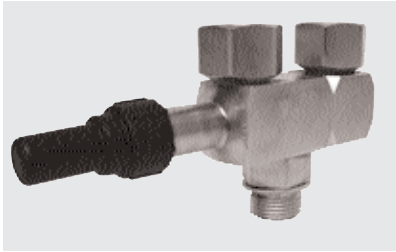

- Optimized body chamber provides maximum flow to assure high relief discharge capacities.
- Internal metal to metal seat with no seals or bearings to assure compatibility with all new refrigerants and oils.
- Custom connections available including rotolock, flare, solder, and O-Ring seal.
- Efficient space-saving low profile design.
- Meets ASHRAE 15, ASME Codes, National Board certified.
- Recognized under the component program of Underwriters Laboratories for use in the USA and Canada.
- Operating temperature range from -40°F to 300°F.
- Maximum working pressure of 500 psig; burst pressure of 2500 psig.

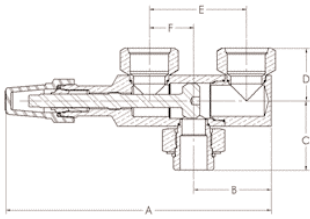

| Part No. | Inlet             | Outlets           | A (in.)  | B (in.) | C (in.) | D (in.) | E (in.) | F (in.) |
|----------|-------------------|-------------------|----------|---------|---------|---------|---------|---------|
| A 17921  | 1/2 NPTFE         | 1/2 NPTFI         | 6        | 1-3/4   | 1-3/4   | 1-3/8   | 2-1/16  | 3/4     |
| A 17922  | 3/4 NPTFE         | 3/4 NPTFI         | 6        | 1-3/4   | 1-7/8   | 1-3/8   | 2-1/16  | 3/4     |
| A 17923  | 1 NPTFE           | 1 NPTFI           | 8-11/16  | 2-7/16  | 2-3/8   | 1-7/8   | 3-1/8   | 1-7/16  |
| A 17924  | 1 1/4 NPTFE       | 1 1/4 NPTFI       | 8-7/8    | 2-7/16  | 2-7/16  | 2-1/8   | 3-1/8   | 1-7/16  |
| B 34550  | 7/8 -14 UNF 2A    | 7/8 -14 UNF 2B    | 6        | 1-3/4   | 1-5/8   | 1-3/8   | 2-1/16  | 3/4     |
| B 34559  | 1 5/16 -12 UNF 2A | 1 5/16 -12 UNF 2B | 8-9/16   | 2-7/16  | 2-1/8   | 1-3/4   | 3-1/8   | 1-7/16  |
| B 34654  | 1 5/8 -12 UNF 2A  | 1 5/8 -12 UNF 2B  | 8-9/16   | 2-7/16  | 2-1/8   | 1-13/16 | 3-1/8   | 1-7/16  |
| B 35272  | 1 NPTFI           | 1 NPTFI           | 11-13/32 | 5-13/32 | 1-15/16 | 1-31/32 | 1-7/8   | 1-7/16  |
| B 35273  | 1 1/4 NPTFI       | 1 1/4 NPTFI       | 11-13/32 | 5-13/32 | 1-15/16 | 1-31/32 | 1-7/8   | 1-7/16  |
| B 35271  | 3/4 NPTFI         | 3/4 NPTFI         | 7-23/32  | 3-17/32 | 1-11/16 | 1-11/16 | 3-5/8   | 3/4     |

## MUELLER ANGLE ISOLATION VALVES



- Optimized body chamber provides maximum flow characteristics
- Design incorporates a fully backseated stem and seat for minimal valve pressure drop.
- Brass construction eliminates corrosion.
- Internal metal to metal seat provides exceptional durability and positive isolation.
- "Quick-Change" packing gland allows easy replacement without refrigerant loss.
- Rotolock or sweat configurations customized to specific applications.
- Asbestos-free packing material.
- Wide operating temperature range of -40°F to 300°F and working pressures up to 500 psig.
- Recognized under the component program of Underwriters Laboratories for use in the USA and Canada.
- Compatible with all new refrigerants and oils.

## SOLDER X SOLDER ANGLE ISOLATION VALVE

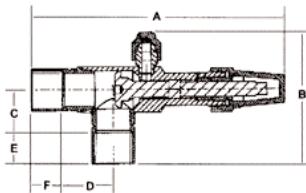

| Part No. | Size                  | Cv | A       | B       | C      | D       | E      | F      | Flare Size |
|----------|-----------------------|----|---------|---------|--------|---------|--------|--------|------------|
| B 34413  | 5/8 ODS x 5/8 ODS     | 6  | 5-27/64 | 2-21/32 | 27/32  | 1-11/64 | 1/2    | 1/2    | 1/4        |
| B 34412  | 7/8 ODS x 7/8 ODS     | 15 | 6-9/16  | 3-3/32  | 29/32  | 1-17/64 | 3/4    | 3/4    | 1/4        |
| B 35224  | 1-1/8 ODS x 1-1/8 ODS | 25 | 7-19/32 | 3-63/64 | 1 5/16 | 1-1/2   | 15/16  | 15/16  | 3/8        |
| B 34479  | 1-1/8 ODS x 1-3/8 ODS | -  | 7-19/32 | 3-3/4   | 1-1/4  | 1-1/2   | 1      | 15/16  | 1/4        |
| B 34594  | 1-3/8 ODS x 1-3/8 ODS | 38 | 9-31/64 | 4-3/16  | 1-1/2  | 1-29/32 | 1      | 1      | 3/8        |
| B 34595  | 1-5/8 ODS x 1-5/8 ODS | 53 | 10-3/64 | 4-11/16 | 1-3/4  | 2-3/16  | 1-3/32 | 1-3/32 | 1/4        |

## SOLDER X ROTOLOCK ANGLE ISOLATION VALVE

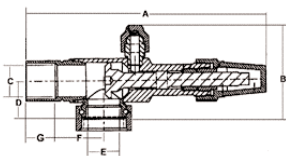

| Part No. | Size                  | Cv | A       | B       | C     | D       | E       | F       | G      | Flare Size |
|----------|-----------------------|----|---------|---------|-------|---------|---------|---------|--------|------------|
| B 34418  | 5/8 ODS x 1 THD       | 6  | 5-27/64 | 2-1/4   | 35/64 | 15/16   | 35/64   | 11/64   | 1/2    | 1/4        |
| B 34417  | 7/8 ODS x 1-1/4 THD   | 15 | 6-9/16  | 2-31/64 | 3/4   | 1 3/64  | 3/4     | 1 17/64 | 3/4    | 1/4        |
| B 34416  | 1-1/8 ODS x 1-1/2 THD | 25 | 7-19/32 | 3       | 1 1/4 | 1       | 1 35/64 | 15/16   | 3/8    |            |
| B 34415  | 1-3/8 ODS x 1-3/4 THD | 38 | 9-33/64 | 3-17/64 | 1-1/4 | 1-13/32 | 1-1/4   | 1-29/32 | 1      | 3/8        |
| B 34414  | 1-5/8 ODS x 2-1/4 THD | 53 | 10-3/64 | 3-35/64 | 1-1/2 | 1-9/16  | 1-1/2   | 2-3/16  | 1-3/32 | 3/8        |

# Plumbing Valves (WOG)



Mueller's Plumbing Valves are made to the highest quality and testing standards available. We offer a large selection of valves for a variety of residential, commercial and industrial applications. Our customers can choose from full port, forged brass ball valves to low pressure, low lead, hose-end valves. We also offer a broad range of gate, stop & waste, gas and specialty valves. All bronze/brass bodied valves have the Mueller brand cast on the valve body, a sign of assured quality and service.

- Most valves meet NSF 61-8 OR 61-9 low lead requirements
- Select valves are certified to CSA, UL, FM, ASSE and IAPMO standards



TUBE & PIPE

METAL FITTINGS & NIPPLES

PLASTIC FITTINGS

VALVES

FILTER-DRIERS & STRAINERS

## BALL VALVE • FULL PORT • 600 PSI

## FORGED BRASS



- 107-403/408HC are 400 PSI Non-Shock WOG
- 107-453/458HC are 600 PSI Non-Shock WOG
- 150 PSI WSP Steam
- Meets NSF approved low lead standards
- CSA Certified – Canadian Standards Association
- -20° to 300°F temperature range
- Dacromet handle
- Hollow ball
- Threaded ends comply with ANSI B1.20.1
- Solder ends comply with ANSI B16.18
- Available in Handy Carton (HC) bin box packaging only

| Part No.        | UPC-A (032888) | Valve Size | Port Size | CV Rating | Inner/Master Carton Qty. | Master Weight (lbs.) |
|-----------------|----------------|------------|-----------|-----------|--------------------------|----------------------|
| <b>Threaded</b> |                |            |           |           |                          |                      |
| 107-403HC       | 074033         | 1/2"       | .571      | 14        | 20/NA                    | 8                    |
| 107-404HC       | 074040         | 3/4"       | .748      | 27        | 15/NA                    | 10                   |
| 107-405HC       | 074057         | 1"         | .945      | 39        | 10/NA                    | 10                   |
| 107-406HC       | 074064         | 1-1/4"     | 1.240     | 70        | 5/NA                     | 7                    |
| 107-407HC       | 074071         | 1-1/2"     | 1.496     | 100       | 5/NA                     | 12                   |
| 107-408HC       | 074088         | 2"         | 1.850     | 198       | 4/NA                     | 14                   |
| <b>Solder</b>   |                |            |           |           |                          |                      |
| 107-453HC       | 074538         | 1/2"       | .571      | 14        | 20/NA                    | 8                    |
| 107-454HC       | 074545         | 3/4"       | .748      | 27        | 15/NA                    | 10                   |
| 107-455HC       | 074552         | 1"         | .945      | 39        | 10/NA                    | 10                   |
| 107-456HC       | 074569         | 1-1/4"     | 1.240     | 70        | 5/NA                     | 7                    |
| 107-457HC       | 074576         | 1-1/2"     | 1.496     | 100       | 5/NA                     | 12                   |
| 107-458HC       | 074583         | 2"         | 1.850     | 198       | 4/NA                     | 15                   |

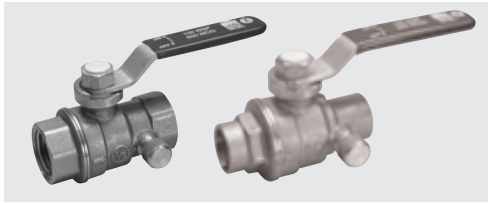

**BALL VALVE • STOP & WASTE • 500 PSI****FORGED BRASS**

- 500 PSI water, oil or air
- Meets NSF approved low lead standards
- -20° to 350°F temperature range
- Suitable for vacuum use up to 7 PSI
- Hollow ball
- Drain port allows draining of the non-pressure side of the valve when closed
- Available in Handy Carton (HC) bin box packaging

| Part No. | UPC-A (032888) | Valve Size | Port Size | CV Rating | Inner/Master Carton Qty. | Master Weight (lbs.) |
|----------|----------------|------------|-----------|-----------|--------------------------|----------------------|
|----------|----------------|------------|-----------|-----------|--------------------------|----------------------|

**Threaded**

|           |        |      |       |      |        |    |
|-----------|--------|------|-------|------|--------|----|
| 107-753   | 077539 | 1/2" | .590" | 14.2 | 10/100 | 42 |
| 107-754   | 077546 | 3/4" | .787" | 28.6 | 10/60  | 32 |
| 107-755   | 077553 | 1"   | .984" | 56.4 | 6/36   | 37 |
| 107-753HC | 077539 | 1/2" | .590" | 14.2 | 12/NA  | 5  |
| 107-754HC | 077546 | 3/4" | .787" | 28.6 | 12/NA  | 8  |
| 107-755HC | 077553 | 1"   | .984" | 56.4 | 15/NA  | 15 |

**Solder**

|           |        |      |       |      |        |    |
|-----------|--------|------|-------|------|--------|----|
| 107-553   | 075535 | 1/2" | .590" | 14.2 | 10/100 | 40 |
| 107-554   | 075542 | 3/4" | .787" | 28.6 | 10/60  | 40 |
| 107-555   | 075559 | 1"   | .984" | 56.4 | 6/36   | 34 |
| 107-553HC | 075535 | 1/2" | .590" | 14.2 | 12/NA  | 5  |
| 107-554HC | 075542 | 3/4" | .787" | 28.6 | 12/NA  | 8  |

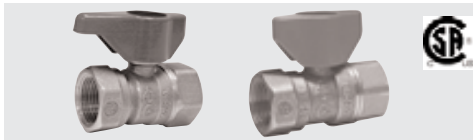
**GAS BALL VALVE • TWO PIECE BODY****FORGED BRASS**

- Quarter-turn operation
- May be used with water 400 WOG
- Operating temperatures -40° to 149° F
- CSA 3-88 (5 PSIG) certified
- CSA Tamper proof (T)
- CSA Certified – Canadian Standards Association
- For use with normal, manufactured, mixed, liquefied petroleum and LP gas-air mixtures
- Threaded ends comply with ANSI B1.20.1
- Available in Handy Carton (HC) bin box packaging



- Quarter turn operation
- CSA-3-88 (5 PSIG) certified
- CSA Certified-Canadian Standards Association
- Chrome plated forged brass ball
- May be used with water 200 WOG
- Threaded ends comply with ANSI B1.20.1
- For use with normal, manufactured, mixed, liquefied petroleum and LP gas-air mixtures
- Made in China

| Part No. | UPC-A (032888) | Valve Size | Inner/Master Carton Qty. | Master Weight (lbs.) |
|----------|----------------|------------|--------------------------|----------------------|
|----------|----------------|------------|--------------------------|----------------------|

**Lever Handle**

|           |        |      |        |    |
|-----------|--------|------|--------|----|
| 110-122   | 101227 | 3/8" | 10/100 | 30 |
| 110-125   | 101258 | 1"   | 6/36   | 23 |
| 110-123HC | 101234 | 1/2" | 20/NA  | 7  |
| 110-124HC | 101241 | 3/4" | 10/NA  | 6  |

**Tee Handle**

|           |        |      |       |    |
|-----------|--------|------|-------|----|
| 111-123HC | 111231 | 1/2" | 25/NA | 13 |
| 111-124HC | 111240 | 3/4" | 25/NA | 15 |

**Lever Handle**

|           |        |      |      |    |
|-----------|--------|------|------|----|
| 110-223HC | 102231 | 1/2" | 1/20 | 10 |
| 110-224HC | 102248 | 3/4" | 1/30 | 10 |

**Lever Handle**

|          |  |      |        |    |
|----------|--|------|--------|----|
| 110-223C |  | 1/2" | 10/100 | 33 |
| 110-224C |  | 3/4" | 10/100 | 48 |

## GAS BALL VALVE • ONE PIECE BODY

## FORGED BRASS



- Quarter turn operation
- CSA- 3-88 (5 PSIG) Certified
- CSA Tamper proof (T)
- CSA Certified – Canadian Standards Association
- UL - Water (258)
- One piece body (3/8" - 3/4")
- Chrome plated forged brass ball
- Coated aluminum handle (3/8" - 3/4")
- Dacromet steel plated handle (1" - 2")
- Threaded ends comply with ANSI B1.20.1
- Available in Handy Carton(HC) bin box packaging

| Part No.            | UPC-A (032888) | Valve Size | Inner/Master Carton Qty. | Master Weight (lbs.) |
|---------------------|----------------|------------|--------------------------|----------------------|
| <b>Lever Handle</b> |                |            |                          |                      |
| 110-522             | 105225         | 3/8"       | 10/100                   | 32                   |
| 110-523             | 105232         | 1/2"       | 10/100                   | 40                   |
| 110-524             | 105249         | 3/4"       | 10/100                   | 61                   |
| 110-525             | 105256         | 1"         |                          |                      |
| 110-522HC           | 105225         | 3/8"       | 10/NA                    | 3                    |
| 110-523HC           | 105232         | 1/2"       | 30/NA                    | 19                   |
| 110-524HC           | 105249         | 3/4"       | 20/NA                    | 24                   |
| 110-525HC           |                | 1"         |                          |                      |

### Lever Handle – Steel

|         |        |        |       |    |
|---------|--------|--------|-------|----|
| 107-705 | 077058 | 1"     | 10/50 | 48 |
| 107-706 | 077065 | 1-1/4" | 10/20 | 31 |
| 107-707 | 077072 | 1-1/2" | 4/20  | 48 |
| 107-708 | 077089 | 2"     | 4/20  | 74 |

### Tee Handle

|         |        |      |        |    |
|---------|--------|------|--------|----|
| 111-523 | 115231 | 1/2" | 10/100 | 39 |
| 111-524 | 115248 | 3/4" | 10/100 | 51 |
| 111-525 | 115255 | 1"   | 6/36   | 40 |

### Flat/Square Head

|           |        |        |        |    |
|-----------|--------|--------|--------|----|
| 113-523   | 135239 | 1/2"   | 10/100 | 37 |
| 113-524   | 135246 | 3/4"   | 10/100 | 56 |
| 113-525   | 135253 | 1"     | 6/36   | 38 |
| 113-526   | 135260 | 1-1/4" | 4/24   | 36 |
| 113-523HC | 135239 | 1/2"   | 20/NA  | 8  |
| 113-524HC | 139246 | 3/4"   | 20/NA  | 12 |

## GAS HEATER BALL VALVE • ONE PIECE BODY

## FORGED BRASS



- CSA- 3-88 (2 PSIG) Certified
- CSA Certified – Canadian Standards Association
- One piece body
- 9/16-24 fine flare thread for 3/8" tube
- Chrome plated forged brass ball
- Coated aluminum handle
- Threaded ends comply with ANSI B1.20.1

| Part No. | UPC-A (032888) | Valve Size   | I/M    | Master Weight |
|----------|----------------|--------------|--------|---------------|
| 117-592  | 175921         | 9/16" x 1/2" | 10/100 | 34            |

## GAS BALL VALVE • FLARE END • ONE PIECE BODY

## FORGED BRASS

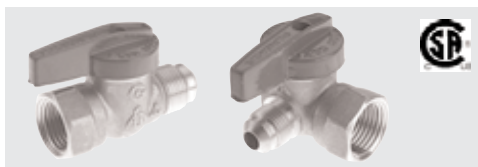

- Manufactured in an ISO 9001 facility
- CSA Z21 (15PSIG) Certified
- CSA Certified – Canadian Standards Association
- One piece body
- Chrome plated forged brass ball
- Coated aluminum handle
- Threaded ends comply with ANSI B1.20.1
- Available in Handy Carton (HC) bin box packaging

| Part No.              | UPC-A (032888) | Valve Size    | Inner/Master Carton Qty. | Master Weight (lbs.) |
|-----------------------|----------------|---------------|--------------------------|----------------------|
| <b>Flare x Female</b> |                |               |                          |                      |
| 114-522               | 145221         | 3/8" x 1/2"   | 10/100                   | 34                   |
| 114-523               | 145238         | 1/2" x 1/2"   | 10/100                   | 37                   |
| 114-524               | 145245         | 15/16" x 3/4" | 10/100                   | 58                   |
| 114-543               | 145436         | 15/16" x 1/2" | 10/100                   | 40                   |
| 114-544               | 145443         | 1/2" x 3/4"   | 10/100                   | 41                   |

### Flare x Female Angle

|         |        |               |        |    |
|---------|--------|---------------|--------|----|
| 114-533 | 145337 | 3/8" x 1/2"   | 10/100 | 33 |
| 114-534 | 145344 | 15/16" x 3/4" | 10/100 | 57 |

## GAS BALL VALVE • FULL PORT • 600 PSI

## FORGED BRASS

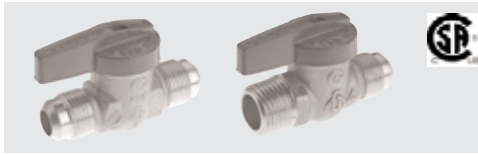

- Manufactured in an ISO 9001 facility
- CSA- 3-88 (2 PSIG) Certified
- CSA Certified – Canadian Standards Association
- One piece body
- Chrome plated forged brass ball
- Coated aluminum handle
- Threaded ends comply with ANSI B1.20.1

| Part No.             | UPC-A (032888) | Valve Size | Inner/Master Carton Qty. | Master Weight (lbs.) |
|----------------------|----------------|------------|--------------------------|----------------------|
| <b>Flare x Flare</b> |                |            |                          |                      |
| 116-502              | 165021         | 3/8"       | 10/100                   | 39                   |
| 116-503              | 165038         | 1/2"       | 10/100                   | 35                   |
| 116-504              | 165045         | 5/8"       | 10/100                   | 54                   |

| Part No.            | UPC-A (032888) | Valve Size  | Inner/Master Carton Qty. | Master Weight (lbs.) |
|---------------------|----------------|-------------|--------------------------|----------------------|
| <b>Flare x Male</b> |                |             |                          |                      |
| 116-512             | 165120         | 3/8" x 1/2" | 10/100                   | 33                   |
| 116-513             | 165137         | 1/2" x 1/2" | 10/100                   | 36                   |

## GAS BALL VALVE • FULL PORT • 600 PSI

## FORGED BRASS



- Manufactured in an ISO 9001 facility
- CSA- 3-88 (2 PSIG) Certified
- CSA Certified – Canadian Standards Association
- Threaded 1/8" with plug for connection to a manometer
- Allows line pressure to be tested at the valve
- One piece body (through 3/4")
- Chrome plated forged brass ball
- Coated aluminum handle (3/8"-3/4")
- Dacromet steel plated handle (1")
- Threaded ends comply with ANSI B1.20.1

| Part No.               | UPC-A (032888) | Valve Size | Inner/Master Carton Qty. | Master Weight (lbs.) |
|------------------------|----------------|------------|--------------------------|----------------------|
| <b>Female x Female</b> |                |            |                          |                      |
| 110-553                | 165539         | 1/2"       | 10/100                   | 42                   |
| 110-554                | 105546         | 3/4"       | 10/100                   | 65                   |
| 110-555                | 105553         | 1"         | 6/36                     | 42                   |

| Part No.             | UPC-A (032888) | Valve Size | Inner/Master Carton Qty. | Master Weight (lbs.) |
|----------------------|----------------|------------|--------------------------|----------------------|
| <b>Flare x Flare</b> |                |            |                          |                      |
| 116-552              | 165526         | 3/8"       | 10/100                   | 43                   |
| 116-553              | 165533         | 1/2"       | 10/100                   | 40                   |

## GATE VALVE • 200 PSI

## BRASS



- 200 PSI Non-shock WOG
- 125 PSI WSP Steam
- Meets NSF approved low lead standards
- Full port
- Non-rising stem
- Cast iron handle
- Threaded ends comply with ANSI B1.20.1
- Solder ends comply with ANSI B16.18
- Available in Handy Carton (HC) bin box packaging

| Part No.        | UPC-A (032888) | Valve Size | Inner/Master Carton Qty. | Master Weight (lbs.) |
|-----------------|----------------|------------|--------------------------|----------------------|
| <b>Threaded</b> |                |            |                          |                      |
| 100-001         | 000018         | 1/4"       | 10/100                   | 60                   |
| 100-002         | 000025         | 3/8"       | 10/100                   | 66                   |
| 100-003         | 000032         | 1/2"       | 10/100                   | 68                   |
| 100-004         | 000049         | 3/4"       | 5/60                     | 53                   |
| 100-005         | 000056         | 1"         | 5/40                     | 47                   |
| 100-006         | 000063         | 1-1/4"     | 5/30                     | 55                   |
| 100-007         | 000070         | 1-1/2"     | 4/24                     | 52                   |
| 100-008         | 000087         | 2"         | 2/16                     | 54                   |
| 100-009         | 000094         | 2-1/2"     | 2/8                      | 55                   |
| 100-010         | 000100         | 3"         | 1/6                      | 49                   |
| 100-011         | 000117         | 4"         | 1/3                      | 44                   |

| Part No.      | UPC-A (032888) | Valve Size | Inner/Master Carton Qty. | Master Weight (lbs.) |
|---------------|----------------|------------|--------------------------|----------------------|
| <b>Solder</b> |                |            |                          |                      |
| 100-502       | 005020         | 3/8"       | 10/100                   | 58                   |
| 100-503       | 005037         | 1/2"       | 10/100                   | 58                   |
| 100-504       | 005044         | 3/4"       | 5/60                     | 51                   |
| 100-506       | 005068         | 1-1/4"     | 5/30                     | 54                   |
| 100-507       | 005075         | 1-1/2"     | 4/24                     | 52                   |
| 100-508       | 005082         | 2"         | 2/16                     | 56                   |
| 100-503HC     | 005037         | 1/2"       | 25/NA                    | 15                   |
| 100-504HC     | 005044         | 3/4"       | 25/NA                    | 21                   |
| 100-505HC     | 005051         | 1"         | 10/NA                    | 12                   |

## STOP & WASTE VALVE • HEAVY DUTY • 150 PSI

BRASS



- Meets NSF approved low lead standards
- For use with water, oil or air
- Heavy construction
- Screw over bonnet
- Large flow area
- Large cast iron handle
- Allows draining of non-pressure side of valve when closed
- Threaded ends comply with ANSI B1.20.1
- Solder ends comply with ANSI B16.18

| Part No.        | UPC-A (032888) | Valve Size | Inner/Master Carton Qty. | Master Weight (lbs.) |
|-----------------|----------------|------------|--------------------------|----------------------|
| <b>Threaded</b> |                |            |                          |                      |
| 105-183HC       | 050839         | 1/2"       | 12/NA                    | 10                   |
| 105-184HC       | 050846         | 3/4"       | 12/NA                    | 12                   |
| <b>Solder</b>   |                |            |                          |                      |
| 105-683HC       | 055834         | 1/2"       | 12/NA                    | 9                    |
| 105-684HC       | 055841         | 3/4"       | 12/NA                    | 10                   |

## STOP & WASTE • COMPRESSION • 125 PSI

BRASS



- Meets NSF approved low lead standards
- CSA Certified – Canadian Standards Association
- For use with water, oil or air
- Compression ends for solderless connection to copper tubing
- Allows draining of non-pressure side of valve when closed

| Part No.  | UPC-A (032888) | Valve Size       | Inner/Master Carton Qty. | Master Weight (lbs.) |
|-----------|----------------|------------------|--------------------------|----------------------|
| 105-613   | 056138         | 1/2" (5/8" O.D.) | 12/72                    | 46                   |
| 105-614   | 056145         | 3/4" (7/8" O.D.) | 6/36                     | 32                   |
| 105-613HC | 056138         | 1/2" (5/8" O.D.) | 16/NA                    | 11                   |
| 105-614HC | 056145         | 3/4" (7/8" O.D.) | 12/NA                    | 11                   |

## BOILER DRAIN • 125 PSI

BRASS



- Easy quarter turn operation
- Maximum 125 PSI working pressure
- Meets NSF approved low lead standards
- UPC approved, complies to ASME A112.18.1 standards
- Chrome plated brass ball
- P.T.F.E. seats
- Rust resistant handle
- 3/4" hose thread outlet
- Pipe threads comply with ANSI B1.20.1
- Hose threads comply with ANSI B1.20.7
- Solder ends comply with ANSI-16.18
- Patent no. D486204S valve body
- Patent no. D472962 valve handle

| Part No.             | UPC-A (032888) | Valve Size | Inner/Master Carton Qty. | Master Weight (lbs.) |
|----------------------|----------------|------------|--------------------------|----------------------|
| <b>Male Threaded</b> |                |            |                          |                      |
| 102-053HC ◇          | 000414         | 1/2"       | 25/NA                    | 8                    |
| 102-054HC §          | 000421         | 3/4"       | 25/NA                    | 9                    |

◇ = 1/2" Male external threads and 1/2" internal solder connection  
 § = 3/4" Male boiler drain is tapped 1/2" female thread

**BOILER DRAIN • 125 PSI****BRASS**

- Meets NSF approved low lead standards
- CSA Certified – Canadian Standards Association (102-003/004/003HC/004HC)
- 3/4" hose thread outlet
- Six lobe cast iron handle
- Pipe threads comply with ANSI B1.20.1
- Hose threads comply with ANSI B1.20.7
- Solder ends comply with ANSI B16.18
- Available in Handy Carton (HC) bin box packaging

| Part No.             | UPC-A (032888) | Valve Size | Inner/Master Carton Qty. | Master Weight (lbs.) |
|----------------------|----------------|------------|--------------------------|----------------------|
| <b>Male Threaded</b> |                |            |                          |                      |
| 102-003 ◊            | 020030         | 1/2"       | 12/72                    | 29                   |
| 102-004              | 020047         | 3/4"       | 12/72                    | 34                   |
| 102-003HC ◊          | 020030         | 1/2"       | 40/NA                    | 15                   |
| 102-004HC            | 020047         | 3/4"       | 35/NA                    | 16                   |

**Female Threaded**

|           |        |      |       |    |
|-----------|--------|------|-------|----|
| 102-103   | 021037 | 1/2" | 12/72 | 30 |
| 102-104   | 021044 | 3/4" | 12/72 | 34 |
| 102-103HC | 021037 | 1/2" | 20/NA | 17 |
| 102-104HC | 021044 | 3/4" | 35/NA | 16 |

◊ = 1/2" Male external threads and 1/2" internal solder connection

**BOILER DRAIN • 125 PSI****BRASS**

- Meets NSF approved low lead standards
- CSA Certified – Canadian Standards Association
- Heavy brass construction
- 3/4" hose thread outlet
- Six lobe cast iron handle
- Pipe threads comply with ANSI B1.20.1
- Hose threads comply with ANSI B1.20.7

| Part No.                 | UPC-A (032888) | Valve Size | Inner/Master Carton Qty. | Master Weight (lbs.) |
|--------------------------|----------------|------------|--------------------------|----------------------|
| <b>Male with locknut</b> |                |            |                          |                      |
| 102-903 ◊                | 029033         | 1/2"       | 12/72                    | 39                   |

◊ = 1/2" Male external threads and 1/2" internal solder connection

**BOILER DRAIN • COMPRESSION****BRASS**

- Rated for 125 psi working pressure
- Stuffing box
- 3/4" hose thread outlet
- Compression Connection
- Six lobe cast iron handle
- Hose threads comply with ANSI B1.20.7

| Part No. | UPC-A (032888) | Valve Size       | Inner/Master Carton Qty. | Master Weight (lbs.) |
|----------|----------------|------------------|--------------------------|----------------------|
| 102-033  | 020337         | 1/2" (5/8" O.D.) | 12/72                    | 39                   |

## HOSE BIBB • QUARTER TURN • 125 PSI

**FORGED BRASS**



- Easy quarter turn operation
- Maximum 125 PSI working pressure
- Meets NSF approved low lead standards
- CSA Certified – Canadian Standards Association
- UPC approved, complies to ASME A112.18.1 standards
- Chrome plated brass ball
- P.T.F.E. seats
- Rust resistant handle
- 3/4" hose thread outlet
- Pipe threads comply with ANSI B1.20.1
- Hose threads comply with ANSI B1.20.7
- Solder ends comply with ANSI-16.18
- Patent no. D472962 valve handle
- Patent no. D5166785 valve body

| Part No.    | UPC-A (032888) | Valve Size | Inner/Master Carton Qty. | Master Weight (lbs.) |
|-------------|----------------|------------|--------------------------|----------------------|
| 103-053HC ◊ | 000391         | 1/2"       | 25/NA                    | 10                   |
| 103-054HC § | 000407         | 3/4"       | 25/NA                    | 12                   |

◊ = 1/2" Male external threads and 1/2" internal solder connection  
 § = Tapped 1/2" female thread

## HOSE BIBB • BALL VALVE DESIGN • 200 PSI

**FORGED BRASS**



- Rated for 200 PSI WOG
- Quarter turn operation
- Chrome plated brass ball
- 3/4" hose thread outlet
- Large flow rate
- Pipe threads comply with ANSI B1.20.1
- Hose threads comply with ANSI B1.20.7
- Available in Handy Carton (HC) bin box packaging

| Part No.    | UPC-A (032888) | Valve Size | Inner/Master Carton Qty. | Master Weight (lbs.) |
|-------------|----------------|------------|--------------------------|----------------------|
| 103-023 ◊   | 030237         | 1/2"       | 10/100                   | 43                   |
| 103-024     | 030244         | 3/4"       | 10/100                   | 56                   |
| 103-023HC ◊ | 030237         | 1/2"       | 20/NA                    | 8                    |
| 103-024HC   | 030244         | 3/4"       | 20/NA                    | 11                   |

◊ = 1/2" Male external threads and 1/2" internal solder connection

## SWING CHECK • "Y" PATTERN • 300 PSI

**BRONZE**

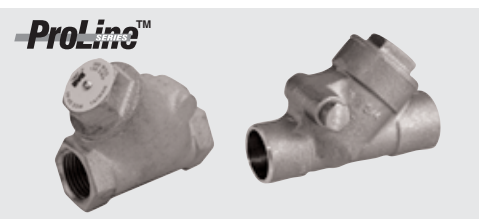

- 300 PSI Non-shock WOG
- 150 PSI WSP Steam
- Heavy bronze construction
- Screwed cap
- Swing type disc with integral seat
- P.T.F.E. face on disc for positive seal
- Can be installed vertically or horizontally
- Threaded ends comply with ANSI B1.20.1
- Solder ends comply with ANSI B16.18

| Part No.        | UPC-A (032888) | Valve Size | Inner/Master Carton Qty. | Master Weight (lbs.) |
|-----------------|----------------|------------|--------------------------|----------------------|
| <b>Threaded</b> |                |            |                          |                      |
| 101-203         | 012035         | 1/2"       | 10/120                   | 73                   |
| 101-204         | 012052         | 3/4"       | 10/80                    | 79                   |
| 101-205         | 012059         | 1"         | 10/60                    | 78                   |
| 101-206         | 012066         | 1-1/4"     | 5/30                     | 59                   |
| 101-207         | 012073         | 1-1/2"     | 4/24                     | 71                   |
| 101-208         | 012080         | 2"         | 2/16                     | 78                   |
| <b>Solder</b>   |                |            |                          |                      |
| 101-703         | 017030         | 1/2"       | 10/120                   | 70                   |
| 101-704         | 017047         | 3/4"       | 10/80                    | 74                   |
| 101-705         | 017054         | 1"         | 10/60                    | 67                   |
| 101-706         | 017061         | 1-1/4"     | 5/30                     | 61                   |
| 101-707         | 017078         | 1-1/2"     | 4/24                     | 66                   |
| 101-708         | 017085         | 2"         | 2/16                     | 50                   |

## SWING CHECK VALVE • 200 PSI

BRASS



- 200 PSI non-shock WOG
- Meets NSF approved low lead standards
- Threaded ends comply with ANSI B1.20.1
- Solder ends comply with ANSI B16.18
- Available in Handy Carton (HC) bin box packaging

| Part No.        | UPC-A (032888) | Valve Size | Inner/Master Carton Qty. | Master Weight (lbs.) |
|-----------------|----------------|------------|--------------------------|----------------------|
| <b>Threaded</b> |                |            |                          |                      |
| 101-001         | 010017         | 1/4"       | 10/100                   | 47                   |
| 101-002         | 010024         | 3/8"       | 10/100                   | 41                   |
| 101-003         | 010031         | 1/2"       | 10/100                   | 42                   |
| 101-004         | 010048         | 3/4"       | 5/60                     | 33                   |
| 101-005         | 010055         | 1"         | 5/40                     | 29                   |
| 101-006         | 010062         | 1-1/4"     | 5/30                     | 42                   |
| 101-007         | 010079         | 1-1/2"     | 4/24                     | 40                   |
| 101-008         | 010086         | 2"         | 2/16                     | 45                   |
| 101-009         | 010093         | 2-1/2"     | 2/8                      | 42                   |
| 101-010         | 010109         | 3"         | 1/6                      | 44                   |
| 101-011         | 010116         | 4"         | 1/3                      | 38                   |
| 101-003HC       | 010031         | 1/2"       | 20/NA                    | 10                   |
| 101-004HC       | 010048         | 3/4"       | 20/NA                    | 30                   |
| 101-005HC       | 010055         | 1"         | 25/NA                    | 18                   |
| 101-006HC       | 010062         | 1-1/4"     | 15/NA                    | 20                   |
| 101-007HC       | 010079         | 1-1/2"     | 12/NA                    | 14                   |
| <b>Solder</b>   |                |            |                          |                      |
| 101-503         | 015036         | 1/2"       | 10/100                   | 40                   |
| 101-504         | 015043         | 3/4"       | 5/60                     | 33                   |
| 101-505         | 015050         | 1"         | 5/40                     | 32                   |
| 101-506         | 015067         | 1-1/4"     | 5/30                     | 43                   |
| 101-507         | 015074         | 1-1/2"     | 4/24                     | 41                   |
| 101-508         | 015081         | 2"         | 2/16                     | 45                   |
| 101-503HC       | 015036         | 1/2"       | 20/NA                    | 9                    |
| 101-504HC       | 015043         | 3/4"       | 20/NA                    | 13                   |

## RADIATOR GATE VALVE • 200 PSI

BRASS



- 60 PSI non-shock hot water & Rated for 15 PSI WSP
- For low pressure steam or circulated hot water
- Adjustable packing
- Rising stem & Heat resistant hand wheel

| Part No. | UPC-A (032888) | Valve Size | Inner/Master Carton Qty. | Master Weight (lbs.) |
|----------|----------------|------------|--------------------------|----------------------|
| 109-405  | 094055         | 1"         | 6/36                     | 62                   |
| 109-406  | 094062         | 1-1/4"     | 6/24                     | 60                   |

## FLOAT VALVES • 125 PSI

**BRONZE**



- Flange provides support against tank walls (male)
- Serrated arm allows easy adjustment of water level
- Pivot assembly prevents breakage during freezing
- Replaceable seals
- Locknut and washer included with male inlet valves
- Available in Handy Carton (HC) bin box packaging

| Part No. | UPC-A (032888) | Valve Size | Rod Size | Inner/Master Carton Qty. | Master Weight (lbs.) |
|----------|----------------|------------|----------|--------------------------|----------------------|
|----------|----------------|------------|----------|--------------------------|----------------------|

### Male Inlet – Plain Outlet

|           |        |      |          |       |    |
|-----------|--------|------|----------|-------|----|
| 109-802   | 098022 | 3/8" | 1/4"-20" | 12/72 | 42 |
| 109-803   | 098039 | 1/2" | 1/4"-20" | 12/72 | 56 |
| 109-804   | 098046 | 3/4" | 1/4"-20" | 6/36  | 40 |
| 109-803HC | 098039 | 1/2" | 1/4"-20" | 12/NA | 9  |
| 109-804HC | 098046 | 3/4" | 1/4"-20" | 12/NA | 12 |

### Male Inlet – Male Outlet

|           |        |      |          |       |    |
|-----------|--------|------|----------|-------|----|
| 109-813   | 098138 | 1/2" | 1/4"-20" | 12/72 | 58 |
| 109-814   | 098145 | 3/4" | 1/4"-20" | 6/36  | 41 |
| 109-813HC | 098138 | 1/2" | 1/4"-20" | 12/NA | 9  |
| 109-814HC | 098145 | 3/4" | 1/4"-20" | 12/NA | 12 |

### Female Inlet – Plain Outlet

|         |        |        |           |      |    |
|---------|--------|--------|-----------|------|----|
| 109-805 | 098053 | 1"     | 5/16"-18" | 4/24 | 42 |
| 109-806 | 098060 | 1-1/4" | 3/8"-16"  | 2/16 | 49 |
| 109-807 | 098077 | 1-1/2" | 3/8"-16"  | 2/12 | 37 |
| 109-808 | 098084 | 2"     | 3/8"-16"  | 2/12 | 41 |

## TANK FLOAT

**COPPER • PLASTIC**



### 109-871-874

- High grade copper construction
- Bonded overlapping joints

### 109-861-864

- Polystyrene construction
- Corrosion resistant
- Impact resistant

| Part No. | UPC-A (032888) | Material | Float Size | Rod Thread | Inner/Master Carton Qty. | Master Weight (lbs.) |
|----------|----------------|----------|------------|------------|--------------------------|----------------------|
|----------|----------------|----------|------------|------------|--------------------------|----------------------|

|         |        |         |    |           |      |    |
|---------|--------|---------|----|-----------|------|----|
| 109-871 | 098718 | Copper  | 5" | 1/4"-20"  | 1/NA | .5 |
| 109-872 | 098725 | Copper  | 6" | 1/4"-20"  | 1/NA | 1  |
| 109-873 | 098732 | Copper  | 8" | 5/16"-18" | 1/NA | 2  |
| 109-874 | 098749 | Copper  | 8" | 3/8"-16"  | 1/NA | 2  |
| 109-861 | 098619 | Plastic | 5" | 1/4"-20"  | 1/64 | 33 |
| 109-862 | 098626 | Plastic | 6" | 1/4"-20"  | 1/40 | 26 |
| 109-863 | 098633 | Plastic | 8" | 5/16"-18" | 1/17 | 20 |
| 109-864 | 098749 | Plastic | 8" | 3/8"-16"  | 1/17 | 20 |

## TANK FLOAT RODS

**BRASS**



- Solid brass
- Threaded on both ends

| Part No. | UPC-A (032888) | Rod Length | Rod Thread | Inner/Master Carton Qty. | Master Weight |
|----------|----------------|------------|------------|--------------------------|---------------|
|----------|----------------|------------|------------|--------------------------|---------------|

|         |        |     |           |       |    |
|---------|--------|-----|-----------|-------|----|
| 109-851 | 098510 | 10" | 1/4"-20"  | 5/250 | 50 |
| 109-852 | 098527 | 12" | 1/4"-20"  | 5/250 | 61 |
| 109-853 | 098534 | 12" | 5/16"-18" | 5/250 | 50 |
| 109-855 | 098558 | 12" | 3/8"-16"  | 5/200 | 58 |



## EVAPORATIVE COOLER VALVE

BRASS



| Part No.  | UPC-A (032888) | Valve Size | Inner/Master Carton Qty. | Master Weight (lbs.) |
|-----------|----------------|------------|--------------------------|----------------------|
| 102-194   | 021945         | 3/4"       | 12/72                    | 36                   |
| 102-194HC | 021945         | 3/4"       | 12/NA                    | 6                    |

- 3/4" hose thread inlet and outlet
- Six lobe cast iron handle
- 1/8" female pipe thread side tap for connection to air conditioner
- Pipe threads comply with ANSI B1.20.1
- Hose threads comply with ANSI B1.20.7
- Available in Handy Carton (HC) bin box packaging

## EVAPORATIVE COOLER FLOAT VALVE • HEAVY DUTY

BRASS



| Part No. | UPC-A (032888) | Valve Size | Inner/Master Carton Qty. | Master Weight (lbs.) |
|----------|----------------|------------|--------------------------|----------------------|
| 109-901  | 099012         | 1/4"       | 20/80                    | 30                   |

- Brass body and rod
- 1/4" compression inlet
- Polyfloat included
- Packaged one set per polybag

## OIL TANK VALVE • BOTTOM SUPPLY

BRASS



| Part No. | UPC-A (032888) | Valve Size  | Inner/Master Carton Qty. | Master Weight (lbs.) |
|----------|----------------|-------------|--------------------------|----------------------|
| 109-241  | 092419         | 1/2" x 3/8" | 6/72                     | 63                   |

- 1/2" MIP X 3/8" MIP
- Brass to brass seat
- Cast iron handle
- Threads comply with ANSI B1.20.1

## ICE MAKER • HUMIDIFIER KIT

COPPER • PLASTIC

- Self piercing saddle valve
- 25' of tubing
- Allows complete connection from water line to appliance
- 993-012 - 15' of tubing



| Part No. | UPC-A (032888) | Tubing Type | Inner/Master Carton Qty. | Master Weight (Lbs.) |
|----------|----------------|-------------|--------------------------|----------------------|
| 993-001  | 930018         | Plastic     | 1/25                     | 17                   |
| 993-002  | 930025         | Copper      | 1/25                     | 42                   |
| 993-012  | 685768316954   | Copper      | 1/15                     | 13                   |

## SADDLE TEES

BRASS • STEEL



| Part No. | UPC-A (032888) | Type          | Inner/Master Carton Qty. | Master Weight (Lbs.) |
|----------|----------------|---------------|--------------------------|----------------------|
| 993-004  | 930049         | Self Piercing | 10/50                    | 27                   |
| 993-014  | 930148         | Standard      | 50/250                   | 48                   |

- Fits 3/8" through 1-1/4" tubing
- Outlet fits 1/4" copper or poly tubing

# Filter Driers



Offering total system protection, Mueller's DRYMASTER® Plus Filter Driers guarantee durability in the most aggressive environmental applications. Incorporating engineering skill and knowledge, this product line continues to evolve after many years of inclusion within Mueller's product offering. Select Mueller to offer a drier that meets the demands of high pressure refrigerants while providing optimum protection from contaminants in refrigeration and air conditioning systems.



- Solid core design, composed of 80% molecular sieves / 20% activated alumina on liquid line models, and 70% activated alumina / 30% molecular sieves on suction line (burnout) models, for exceptional moisture and acid removal.
- Compatible with refrigerants requiring XH11 dessicant.
- High retention filter for removal of particulate as small as 25 microns.
- High-pressure shell and connections designed for MWP up to 610 psig.
- Powder-paint finish, approved for marine applications.
- Tested for all CFC/HCFC/HFC refrigerants (including R 410A) with POE and PAG oils.
- All driers are UL/cUL listed.

TUBE & PIPE  
METAL FITTINGS & NIPPLES  
PLASTIC FITTINGS  
VALVES

## DRYMASTER® PLUS FILTER DRIERS-LIQUID LINE

### DRYMASTER® PLUS LIQUID LINE FILTER DRIERS WITH FLARE CONNECTION

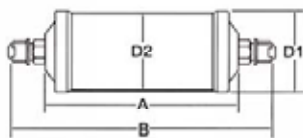

Flare Connection

| Part No. | Model Number | Cubic Inches | Connection Size | Max. Working Pressure | A    | B     | D1   | D2   |
|----------|--------------|--------------|-----------------|-----------------------|------|-------|------|------|
| A 16600  | FL-032       | 3            | 1/4             | 610                   | 2.48 | 4.35  | 2.25 | 2.12 |
| A 16601  | FL-033       | 3            | 3/8             | 610                   | 2.48 | 4.85  | 2.25 | 2.12 |
| A 16606  | FL-052       | 5            | 1/4             | 610                   | 2.88 | 4.68  | 2.25 | 2.12 |
| A 16607  | FL-053       | 5            | 3/8             | 610                   | 2.88 | 5.20  | 2.25 | 2.12 |
| A 16608  | FL-082       | 8            | 1/4             | 610                   | 3.89 | 5.72  | 2.25 | 2.12 |
| A 16609  | FL-083       | 8            | 3/8             | 610                   | 3.89 | 6.51  | 2.25 | 2.12 |
| A 16610  | FL-084       | 8            | 1/2             | 610                   | 3.89 | 6.51  | 2.25 | 2.12 |
| A 16612  | FL-162       | 16           | 1/4             | 610                   | 4.22 | 6.05  | 3.17 | 2.98 |
| A 16613  | FL-163       | 16           | 3/8             | 610                   | 4.22 | 6.58  | 3.17 | 2.98 |
| A 16614  | FL-164       | 16           | 1/2             | 610                   | 4.22 | 6.91  | 3.17 | 2.98 |
| A 16615  | FL-165       | 16           | 5/8             | 610                   | 4.22 | 7.25  | 3.17 | 2.98 |
| A 16618  | FL-303       | 30           | 3/8             | 610                   | 7.24 | 9.59  | 3.17 | 2.98 |
| A 16619  | FL-304       | 30           | 1/2             | 610                   | 7.24 | 9.91  | 3.17 | 2.98 |
| A 16620  | FL-305       | 30           | 5/8             | 610                   | 7.24 | 10.23 | 3.17 | 2.98 |
| A 16623  | FL-413       | 41           | 3/8             | 610                   | 7.44 | 9.64  | 3.67 | 3.51 |
| A 16624  | FL-414       | 41           | 1/2             | 610                   | 7.44 | 9.94  | 3.67 | 3.51 |
| A 16625  | FL-415       | 41           | 5/8             | 610                   | 7.44 | 10.28 | 3.67 | 3.51 |

FLITER DRIERS & STRAINERS

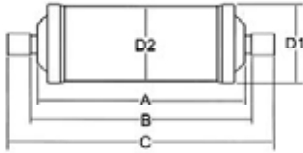

**DRYMASTER® PLUS FILTER DRIERS-LIQUID LINE****DRYMASTER® PLUS LIQUID LINE FILTER DRIERS WITH SOLDER CONNECTION**

Solder Connection

| Part No. | Model Number | Cubic Inches | Connection Size | Max. Working Pressure | A    | B    | C     | D1   | D2   |
|----------|--------------|--------------|-----------------|-----------------------|------|------|-------|------|------|
| A 16640  | SD-032       | 3            | 1/4             | 610                   | 2.48 | 3.23 | 3.85  | 2.25 | 2.12 |
| A 16641  | SD-033       | 3            | 3/8             | 610                   | 2.48 | 3.36 | 3.98  | 2.25 | 2.12 |
| A 16646  | SD-052       | 5            | 1/4             | 610                   | 2.88 | 3.58 | 4.20  | 2.25 | 2.12 |
| A 16647  | SD-053       | 5            | 3/8             | 610                   | 2.88 | 3.75 | 4.37  | 2.25 | 2.12 |
| A 16648  | SD-082       | 8            | 1/4             | 610                   | 3.89 | 4.61 | 5.23  | 2.25 | 2.12 |
| A 16649  | SD-083       | 8            | 3/8             | 610                   | 3.89 | 4.74 | 5.36  | 2.25 | 2.12 |
| A 16650  | SD-084       | 8            | 1/2             | 610                   | 3.89 | 4.75 | 5.51  | 2.25 | 2.12 |
| A 16653  | SD-163       | 16           | 3/8             | 610                   | 4.22 | 5.09 | 5.71  | 3.17 | 2.98 |
| A 16654  | SD-164       | 16           | 1/2             | 610                   | 4.22 | 5.10 | 5.86  | 3.17 | 2.98 |
| A 16655  | SD-165       | 16           | 5/8             | 610                   | 4.22 | 5.28 | 6.28  | 3.17 | 2.98 |
| A 16657  | SD-166       | 16           | 3/4             | 500                   | 4.22 | 5.51 | 6.75  | 3.17 | 2.98 |
| A 16656  | SD-167       | 16           | 7/8             | 500                   | 4.22 | 5.35 | 6.85  | 3.17 | 2.98 |
| A 16658  | SD-303       | 30           | 3/8             | 610                   | 7.24 | 8.07 | 8.69  | 3.17 | 2.98 |
| A 16659  | SD-304       | 30           | 1/2             | 610                   | 7.24 | 8.13 | 8.89  | 3.17 | 2.98 |
| A 16660  | SD-305       | 30           | 5/8             | 610                   | 7.24 | 8.27 | 9.27  | 3.17 | 2.98 |
| A 16662  | SD-307       | 30           | 7/8             | 500                   | 7.24 | 8.15 | 9.65  | 3.17 | 2.98 |
| A 16661  | SD-309       | 30           | 1-1/8           | 500                   | 7.24 | 8.15 | 9.97  | 3.17 | 2.98 |
| A 16663  | SD-413       | 41           | 3/8             | 610                   | 7.44 | 8.23 | 8.85  | 3.67 | 3.51 |
| A 16664  | SD-414       | 41           | 1/2             | 610                   | 7.44 | 8.19 | 8.95  | 3.67 | 3.51 |
| A 16665  | SD-415       | 41           | 5/8             | 610                   | 7.44 | 8.31 | 9.31  | 3.67 | 3.51 |
| A 16667  | SD-417       | 41           | 7/8             | 500                   | 7.44 | 8.39 | 9.89  | 3.67 | 3.51 |
| A 16668  | SD-419       | 41           | 1-1/8           | 500                   | 7.44 | 8.19 | 10.01 | 3.67 | 3.51 |

**DRYMASTER® PLUS FILTER DRIERS-SUCTION LINE****DRYMASTER® PLUS SUCTION LINE FILTER DRIERS, FLARE CONNECTION**

Nominal capacity (tons)  
Evaporator temperature 40°F

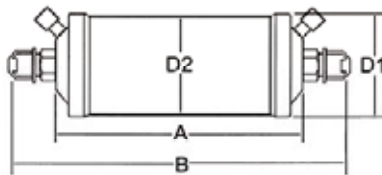

| Part No. | Model Number | Cubic Inches | Cubic Size | Max Working Pressure | R 404A |       |        | R 22 |     | D1  | D2 |
|----------|--------------|--------------|------------|----------------------|--------|-------|--------|------|-----|-----|----|
|          |              |              |            |                      | R 134a | R 507 | R 410A | A    | B   |     |    |
| A 17225  | FDL-164-TT   | 16           | 1/2        | 610                  | 1.70   | 2.40  | 3.00   | 4.3  | 6.9 | 3.1 | 3  |
| A 17226  | FDL-165-TT   | 16           | 5/8        | 610                  | 2.70   | 3.70  | 4.30   | 4.3  | 7.2 | 3.1 | 3  |

## DRYMASTER® PLUS FILTER DRIERS-SUCTION LINE



### DRYMASTER® PLUS SUCTION LINE FILTER DRIERS, SOLDER CONNECTION

Nominal capacity (tons)  
Evaporator temperature 40°F

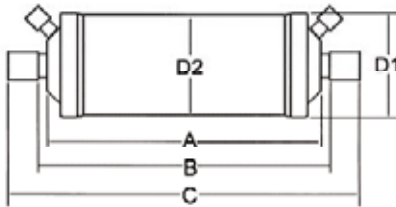

| Part No. | Number      | Model Inches | Cubic Size | Max Working Pressure | R 134a | R 507 | R22    |     |     |      | DI  | D |
|----------|-------------|--------------|------------|----------------------|--------|-------|--------|-----|-----|------|-----|---|
|          |             |              |            |                      |        |       | R 410A | A   | B   | C    |     |   |
| A 17224  | FDS-164-TT  | 16           | 1/2        | 610                  | 1.70   | 2.40  | 3.00   | 4.3 | 4.6 | 6.0  | 3.1 | 3 |
| A 17227  | FDS-165-TT  | 16           | 5/8        | 610                  | 2.70   | 3.70  | 4.30   | 4.3 | 4.6 | 6.2  | 3.1 | 3 |
| A 17228  | FDS-166-TT  | 16           | 3/4        | 510                  | 3.40   | 4.90  | 5.70   | 4.3 | 4.6 | 6.7  | 3.1 | 3 |
| A 17229  | FDS-167-TT  | 16           | 7/8        | 510                  | 3.90   | 5.40  | 6.30   | 4.3 | 4.7 | 6.8  | 3.1 | 3 |
| A 17230  | FDS-169-TT  | 16           | 1-1/8      | 510                  | 4.60   | 6.50  | 7.50   | 4.3 | 4.7 | 6.8  | 3.1 | 3 |
| A 17231  | FDSF-309-TT | 30           | 1-1/8      | 510                  | 5.70   | 7.70  | 8.90   | 7.3 | 7.7 | 9.8  | 3.1 | 3 |
| A 17300  | FDS-305-TT  | 30           | 5/8        | 610                  | 3.10   | 4.30  | 5.10   | 7.3 | 7.6 | 9.2  | 3.1 | 3 |
| A 17301  | FDS-306-TT  | 30           | 3/4        | 510                  | 4.00   | 5.40  | 6.30   | 7.3 | 7.6 | 9.7  | 3.1 | 3 |
| A 17302  | FDS-307-TT  | 30           | 7/8        | 510                  | 4.60   | 6.30  | 7.40   | 7.3 | 7.7 | 9.8  | 3.1 | 3 |
| A 17232  | FDS-3011-TT | 30           | 1-3/8      | 360                  | 5.70   | 7.70  | 8.90   | 7.3 | 8.6 | 10.5 | 3.1 | 3 |
| A 17233  | FDS-3013-TT | 30           | 1-5/8      | 360                  | 5.70   | 7.70  | 8.90   | 7.3 | 8.7 | 11.3 | 3.1 | 3 |

## DRYMASTER PLUS® FILTER DRIERS-HEAT PUMP



- May be mounted in any position.
- Provides in-depth filtration.
- Internal construction allows reversible refrigerant flow.
- No external check valves required.
- Reduces cost by eliminating system complexity.
- UL listed for use in the USA and Canada.

Solder Type

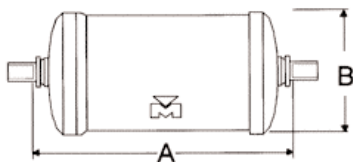

Flare Type

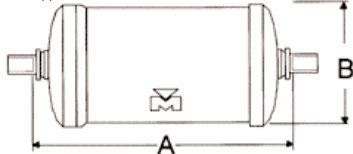

| Part No. | Model No. | Fitting Size | Cu. In. Vol. | A     | Diameter B |
|----------|-----------|--------------|--------------|-------|------------|
| A 17388  | HPF-083   | 3/8 Flare    | 8            | 6-1/4 | 2-1/4      |
| A 17389  | HPS-083   | 3/8 Solder   | 8            | 5-5/8 | 2-1/4      |
| A 17390  | HPF-163   | 3/8 Flare    | 16           | 6-3/4 | 3-1/8      |
| A 17391  | HPS-163   | 3/8 Solder   | 16           | 5-7/8 | 3-1/8      |
| A 17392  | HPS-164   | 1/2 Solder   | 16           | 6-1/8 | 3-1/8      |
| A 17983  | HPF-164   | 1/2 Flare    | 16           | 7     | 3-1/8      |
| A 17984  | HPF-165   | 5/8 Flare    | 16           | 7-3/8 | 3-1/8      |
| A 17985  | HPS-165   | 5/8 Solder   | 16           | 6-3/8 | 3-1/8      |



# Strainers



Mueller's strive for excellence brings forth another growing product line. Offering the flexibility of configuration and material construction, it is now possible to efficiently and economically protect refrigeration and water systems. Included are cast bronze, brass y-type and inline copper strainers. Depend on Mueller's engineering advancements for the development of new industry expectations.



TUBE & PIPE

METAL FITTINGS & NIPPLES

PLASTIC FITTINGS

VALVES

FILTER-DRYERS & STRAINERS

## WATER STRAINER

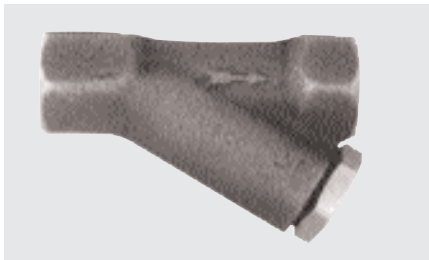

- Suitable for refrigeration and water systems.
- Cast Bronze construction for efficient and economical inline installation.
- Maximum temperature of 200°F.

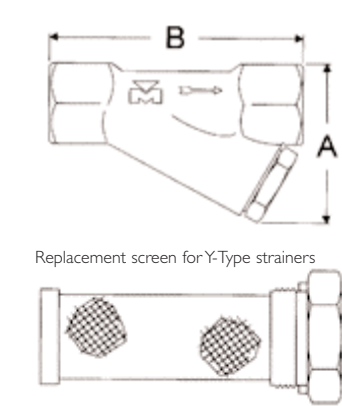

These sub-assemblies consist of a screen, a plug and an o-ring. Recommended for the protection of condensing water regulators, water coolers, dispensing equipment and similar applications.

### Y-TYPE-THREADED

| Part No. | Size<br>NPTI x NPTI | Dim<br>A | Dim<br>B | Screen<br>Mesh | Sq. In.<br>Screen<br>Area | Wt./Ea. |
|----------|---------------------|----------|----------|----------------|---------------------------|---------|
| A 15176  | 3/8                 | 2-3/16   | 3-5/16   | 50             | 3-1/2                     | .68     |
| A 15184  | 3/8                 | 2-3/16   | 3-3/8    | 100            | 3-1/2                     | .68     |
| A 15177  | 1/2                 | 2-3/16   | 3- 5/16  | 50             | 3-1/2                     | .66     |
| A 15159  | 1/2                 | 2-3/16   | 3-3/8    | 100            | 3-1/2                     | .66     |
| A 15178  | 3/4                 | 3        | 4-7/16   | 50             | 6-1/2                     | 1.42    |

### Y-TYPE-SOLDER TO SOLDER

| Part No. | Size<br>NPTI x NPTI | Dim<br>A | Dim<br>B | Screen<br>Mesh | Sq. In.<br>Screen<br>Area | Wt./Ea. |
|----------|---------------------|----------|----------|----------------|---------------------------|---------|
| A 15192  | 3/8                 | 2-3/16   | 3-9/32   | 50             | 3-1/2                     | .78     |
| A 15196  | 3/8                 | 2-3/16   | 3-9/32   | 100            | 3-1/2                     | .78     |
| A 15193  | 1/2                 | 2-3/16   | 3-9/32   | 50             | 3-1/2                     | .72     |
| A 15197  | 1/2                 | 2-3/16   | 3-9/32   | 100            | 3-1/2                     | .72     |
| A 15194  | 3/4                 | 3        | 4-7/16   | 50             | 6-1/2                     | 1.47    |

### REPLACEMENT SCREEN SUB-ASSEMBLIES FOR Y-TYPE STRAINERS

| Part No. | Screen Mesh | For Use With Assembly Numbers           |
|----------|-------------|---|
| A 15122  | 100         | A 15159, A 15184, A 15196, and A 15197, |
| A 15123  | 50          | A 15176, A 15177, A 15192, and A 15193, |
| A 15124  | 50          | A 15178 and A 15194                     |



## INLINE Y STRAINER

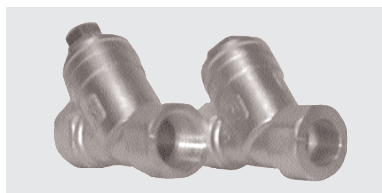

- Solder Connection Sizes 1/4 thru 2-1/2".
- Threaded Connection Sizes 1/4 - 2-1/2".
- Flexible design offers interchangeable cap and mesh size options as part of the standard product offering.
- Compatible with all CFC, HCFC and HFC refrigerants and oils.
- Wide operating temperature range of -40°F to 300°F, and working pressure up to 700 psig.

Maintenance Cap Option

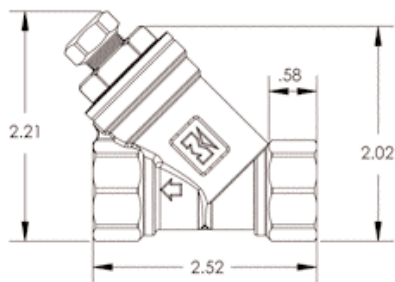

Solid Cap Option

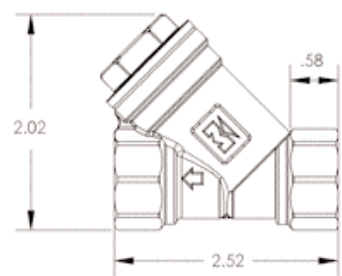

| Part Number ** | Plumbing System |               | Refrigeration System |               | Type         | Cap, Screen & Gasket Rebuild Kit ** |
|----------------|-----------------|---------------|----------------------|---------------|--------------|-------------------------------------|
|                | Size            | Compatibility | Size                 | Compatibility |              |                                     |
| A 18069        | 1/4             | Yes           | 3/8                  | Yes           | 1/4 - 18 NPT |                                     |
| A 18070        | 1/4             | Yes           | 3/8                  | Yes           | Solder Cup   |                                     |
| A 18071        | 3/8             | Yes           | 1/2                  | Yes           | 3/8 - 18 NPT | A 18080                             |
| A 18072        | 3/8             | Yes           | 1/2                  | Yes           | Solder Cup   |                                     |
| A 18073        | 1/2             | Yes           | 5/8                  | Yes           | 1/2 - 14 NPT |                                     |
| A 18074        | 1/2             | Yes           | 5/8                  | Yes           | Solder Cup   |                                     |

\* Prefix required for Cap Option  
 \*\* Prefix required for Screen Option  
 Additional sizes to be released.

Contact factory for more details, or check [www.muellerindustries.com](http://www.muellerindustries.com) for current data.

Prefixed for Cap Options:  
 M = Maintenance Cap  
 S = Solid Cap

Prefixed for Screen Mesh Options:  
 F = 20  
 G = 40  
 H = 50  
 I = 60  
 J = 80  
 K = 100

Examples:  
 AMF18069, 1/4 Threaded Y-Strainer with Maintenance Cap, 20 Mesh Screen  
 ASF18069, 1/4 Threaded Y-Strainer with Solid Cap, 20 Mesh Screen  
 AMF18070, 1/4 Solder Y-Strainer with Maintenance Cap, 20 Mesh Screen  
 ASF18070, 1/4 Solder Y-Strainer with Solid Cap, 20 Mesh Screen

## MCC INLINE STRAINER



- Connection Sizes 1/4 thru 5/8".
- Screens available in 80, 100 and 120 mesh.
- Internal components constructed of brass and stainless steel.
- Resistant to high pressure, turbulent and pulsating flow conditions.
- Compatible with all CFC, HCFC and HFC refrigerants and oils.
- Wide operating temperature range of -40° F to 300°F, and working pressure up to 700 psig.
- All strainers are UL/cUL recognized.

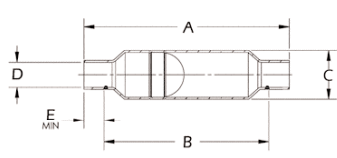

| Part Number | Size | A (in) | B (in) | C (in) | D (in) | E (in) | Internal Assembly Volume | Screen Mesh | Screen Area | Filtration Capacity (micron) |
|-------------|------|--------|--------|--------|--------|--------|--------------------------|-------------|-------------|------------------------------|
| A 18020     | 1/4  | 2.77   | 2.15   | 0.75   | 1/4    | 0.31   | .655                     | 80          | 0.4         | 240                          |
| A 18021     | 3/8  | 3.12   | 2.50   | 0.75   | 3/8    | 0.31   | .790                     | 80          | 0.4         | 240                          |
| A 18022     | 1/2  | 3.01   | 2.25   | 1.00   | 1/2    | 0.38   | 1.25                     | 80          | 1.0         | 240                          |
| A 18023     | 5/8  | 3.50   | 2.50   | 1.00   | 5/8    | 0.50   | 1.54                     | 80          | 1.0         | 240                          |
| A 18024     | 1/4  | 2.77   | 2.15   | 0.75   | 1/4    | 0.31   | .655                     | 100         | 0.4         | 175                          |
| A 18025     | 3/8  | 3.12   | 2.50   | 0.75   | 3/8    | 0.31   | .790                     | 100         | 0.4         | 175                          |
| A 18026     | 1/2  | 3.01   | 2.25   | 1.00   | 1/2    | 0.38   | 1.25                     | 100         | 1.0         | 175                          |
| A 18027     | 5/8  | 3.50   | 2.50   | 1.00   | 5/8    | 0.50   | 1.54                     | 100         | 1.0         | 175                          |
| A 18028     | 1/4  | 2.77   | 2.15   | 0.75   | 1/4    | 0.31   | .655                     | 120         | 0.4         | 140                          |
| A 18029     | 3/8  | 3.12   | 2.50   | 0.75   | 3/8    | 0.31   | .790                     | 120         | 0.4         | 140                          |
| A 18030     | 1/2  | 3.01   | 2.25   | 1.00   | 1/2    | 0.38   | 1.25                     | 120         | 1.0         | 140                          |
| A 18031     | 5/8  | 3.50   | 2.50   | 1.00   | 5/8    | 0.50   | 1.54                     | 120         | 1.0         | 140                          |



## INDEX BY DESCRIPTION

### Copper Tube 2–4

|                            |   |
|----------------------------|---|
| Copper Tube Plumbing       | 2 |
| Copper Tube Refrigeration  | 3 |
| Plastic Coated Copper Tube | 3 |

### Copper Fittings

#### Wrot & Cast Pressure Fittings

|                 |       |
|-----------------|-------|
| 45° Elbow       | 15–16 |
| 45° Wye         | 37    |
| 90° Elbow       | 15–20 |
| Adapter         | 8–11  |
| Bushing         | 11–12 |
| Cap             | 12    |
| Copper Strap    | 29    |
| Coupling        | 12–15 |
| Cross           | 15    |
| Fitting Reducer | 21    |
| Flange          | 27    |
| Hanger          | 29    |
| Plug            | 22    |
| P-Trap          | 22    |
| Return Bend     | 22–23 |
| Tee             | 23–28 |
| Union           | 28    |

#### Iron Fittings

|                    |       |
|--------------------|-------|
| 45° Elbow          | 30    |
| 45° Street Elbow   | 31    |
| 90° Elbow          | 31    |
| 90° Reducing Elbow | 32    |
| 90° Street Elbow   | 31    |
| Cap                | 37    |
| Coupling           | 35    |
| Cross              | 40    |
| Extension Piece    | 32    |
| Floor Flange       | 39    |
| Hex Bushing        | 38    |
| Locknut            | 40    |
| Merchant Coupling  | 37    |
| Plug               | 37    |
| Reducing Coupling  | 36    |
| Reducing Tee       | 34–35 |
| Side Outlet Elbow  | 33    |
| Service Tee        | 33    |
| Tee                | 33    |
| Union              | 39    |

#### Steel Nipples

|                                  |    |
|----------------------------------|----|
| Pipe Nipple Assortment           | 48 |
| Pre-Cut Pipe 1/4"                | 46 |
| Pre-Cut Pipe 3/8"                | 46 |
| Pre-Cut Pipe 1/2"                | 46 |
| Pre-Cut Pipe 3/4"                | 46 |
| Pre-Cut Pipe 1"                  | 46 |
| Pre-Cut Pipe 1-1/4"              | 46 |
| Pre-Cut Pipe 1-1/2"              | 46 |
| Pre-Cut Pipe 2"                  | 46 |
| Seamless Steel Pipe Nipples 1/8" | 49 |
| Seamless Steel Pipe Nipples 1/4" | 49 |
| Seamless Steel Pipe Nipples 3/8" | 49 |
| Seamless Steel Pipe Nipples 1/2" | 50 |

### Tube & Pipe

#### Line Sets 4–5

|                      |   |
|----------------------|---|
| Line Sets            | 5 |
| Line Sets Schematic  | 4 |
| Mini Split Line Sets | 5 |

### Metal Fittings & Nipples

|                                    |       |
|------------------------------------|-------|
| Seamless Steel Pipe Nipples 3/4"   | 50    |
| Seamless Steel Pipe Nipples 1"     | 50    |
| Seamless Steel Pipe Nipples 1-1/2" | 51    |
| Seamless Steel Pipe Nipples 2"     | 51    |
| Seamless Steel Pipe Nipples 2-1/2" | 51    |
| Seamless Steel Pipe Nipples 3"     | 52    |
| Seamless Steel Pipe Nipples 4"     | 52    |
| Seamless Steel Pipe Nipples 6"     | 52    |
| Welded Steel Pipe Nipple 1/8"      | 41    |
| Welded Steel Pipe Nipple 1/4"      | 41    |
| Welded Steel Pipe Nipple 3/8"      | 42    |
| Welded Steel Pipe Nipple 1/2"      | 42    |
| Welded Steel Pipe Nipple 3/4"      | 42    |
| Welded Steel Pipe Nipple 1"        | 43    |
| Welded Steel Pipe Nipple 1-1/4"    | 43    |
| Welded Steel Pipe Nipple 1-1/2"    | 43    |
| Welded Steel Pipe Nipple 2"        | 44    |
| Welded Steel Pipe Nipple 2-1/2"    | 44    |
| Welded Steel Pipe Nipple 3"        | 44    |
| Welded Steel Pipe Nipple 4"        | 45    |
| Welded Steel Pipe Nipple 6"        | 45    |
| XH Steel Pipe Nipples 1/8"         | 53    |
| XH Steel Pipe Nipples 1/4"         | 53    |
| XH Steel Pipe Nipples 3/8"         | 53    |
| XH Steel Pipe Nipples 1/2"         | 54    |
| XH Steel Pipe Nipples 3/4"         | 54    |
| XH Steel Pipe Nipples 1"           | 54    |
| XH Steel Pipe Nipples 1-1/4"       | 55    |
| XH Steel Pipe Nipples 1-1/2"       | 55    |
| XH Steel Pipe Nipples 2"           | 55    |
| XH Steel Pipe Nipples 2-1/2"       | 55–56 |
| XH Steel Pipe Nipples 3"           | 56    |
| XH Steel Pipe Nipples 4"           | 56    |
| XH Steel Pipe Nipples 6"           | 56    |

#### Red Brass Fittings

|                          |    |
|--------------------------|----|
| 45° Elbow                | 58 |
| 45° Street Elbow         | 58 |
| 90° Elbow                | 57 |
| 90° Reducing Elbow       | 58 |
| 90° Street Elbow         | 57 |
| Cap                      | 61 |
| Cored Plug               | 61 |
| Coupling                 | 59 |
| Cross                    | 59 |
| Hex Bushing              | 60 |
| Locknut                  | 60 |
| Reducing Coupling        | 60 |
| Reducing Tee             | 59 |
| Solid Plug               | 61 |
| Tee                      | 59 |
| Union                    | 61 |
| <b>Red Brass Nipples</b> |    |
| Nipple 1/8"              | 62 |
| Nipple 1/4"              | 62 |

#### Pipe 6–7

|                          |   |
|--------------------------|---|
| 10 Ft Threaded           | 6 |
| 21 Ft Threaded & Coupled | 6 |
| ABS DWV Pipe             | 7 |

|               |    |
|---------------|----|
| Nipple 3/8"   | 62 |
| Nipple 1/2"   | 63 |
| Nipple 3/4"   | 63 |
| Nipple 1"     | 63 |
| Nipple 1-1/4" | 64 |
| Nipple 1-1/2" | 64 |
| Nipple 2"     | 64 |

#### Yellow Brass Fittings

|                  |    |
|------------------|----|
| 45° Elbow        | 65 |
| 45° Street Elbow | 65 |
| 90° Elbow        | 65 |
| 90° Street Elbow | 65 |
| Cap              | 66 |
| Coupling         | 66 |
| Face Bushing     | 66 |
| Hex Bushing      | 66 |
| Solid Plug       | 66 |
| Tee              | 65 |

#### Yellow Brass Nipples

|             |    |
|-------------|----|
| Nipple 1/8" | 67 |
| Nipple 1/4" | 67 |
| Nipple 3/8" | 67 |

#### Flare Brass Fittings & Flanges

|                          |       |
|--------------------------|-------|
| 90° Elbow, Union         | 73    |
| 90° Elbow                | 72    |
| 90° Solder Elbow         | 73    |
| 90° Elbow                | 73-74 |
| 90° Swivel Elbow         | 74    |
| Bushing                  | 76    |
| Connectors               | 69    |
| Flare Gasket             | 75    |
| Flare Seal Bonnet        | 75    |
| Flange                   | 76-77 |
| Flare Plugs              | 75    |
| Flare Seal Cap           | 76    |
| Fusible Pipe Flugs       | 72    |
| Gasket                   | 78    |
| Half Union               | 70-71 |
| Swivel Unions            | 71    |
| Flare to Extension       | 69    |
| FLare Union              | 71    |
| Internal Flare Unions    | 71    |
| Long Forged Nuts         | 68    |
| Pipe Plugs-Brass         | 76    |
| Reducing Unions          | 70    |
| Refrigerant Drum Adapter | 72    |
| Right Angle Two-Way Tee  | 74    |
| Short Forged Nut         | 68    |
| Reducing Nut             | 68    |
| Three-Way Tee            | 74-75 |
| Three-Way Reducing Tee   | 75    |
| Two-Way Tee              | 74    |
| Union                    | 69    |



## INDEX BY DESCRIPTION

### Schedule 40

|                        |       |
|------------------------|-------|
| 45° Elbow              | 82    |
| 90° Elbow              | 80–81 |
| Adapter                | 83–84 |
| Bushing                | 84–85 |
| Cap                    | 85–86 |
| Coupling               | 82–83 |
| Cross                  | 82    |
| Deep Socket Coupling   | 87    |
| Plug                   | 86    |
| P-Trap                 | 87    |
| Riser                  | 83    |
| Tee                    | 78–79 |
| Union                  | 87    |
| <b>Insert Fittings</b> |       |
| 90° Cap                | 90    |
| 90° Elbow              | 90    |
| Adapter                | 88–89 |
| Bushing                | 89    |
| Coupling               | 90    |

### Refrigeration Valves

|                                   |         |
|-----------------------------------|---------|
| CYCLEMASTER® Actuated Valves      | 153     |
| CYCLEMASTER® Ball Valves          | 154     |
| Check Valves                      | 162     |
| CMV Series Magnetic Check Valves  | 163     |
| Compressor Valves & Kits          | 158–161 |
| Hi-Flow Residential Check Valves  | 163     |
| Mueller Angle Isolation Valves    | 166     |
| Packed Line Valves                | 155–156 |
| Packless Diaphragm Valves         | 157     |
| Pressure Relief Valves            | 165     |
| Reliefmaster Change-Over Manifold | 166     |
| Rupture Disc                      | 164     |

### Filter Driers

|                                   |         |
|-----------------------------------|---------|
| Drymaster® Plus Filter Driers     | 177–179 |
| Drymaster® Plus Heat Pump Filters | 181     |

### Plastic Fittings

#### ABS DWV Fittings

|                          |         |
|--------------------------|---------|
| Adapter                  | 91–99   |
| Bushing                  | 95      |
| Cap                      | 97,99   |
| Closet Flange            | 118–121 |
| Coupling                 | 99      |
| Drum Trap                | 148     |
| Elbows                   | 100–107 |
| Nut                      | 99,130  |
| Pipe Increaser           | 92      |
| Plug                     | 94–95   |
| P-Trap                   | 117–118 |
| Return Bend              | 116     |
| Swivel Tray Plug Adapter | 122     |
| Tail Piece Adapter       | 146     |
| Tee                      | 107–111 |
| Trap Adapter             | 92–94   |
| Washer                   | 100     |
| Wye                      | 111–116 |

### Valves

|                           |     |
|---------------------------|-----|
| Screw Bonnet Check Valves | 164 |
|---------------------------|-----|

#### Plumbing Valves

|                                 |         |
|---------------------------------|---------|
| Ball Valves                     | 167–213 |
| Ball Valves – Brass             | 167–168 |
| Ball Valves – PVC               | 170     |
| Ball Valves – CPVC              | 171     |
| Boiler Drains                   | 172–173 |
| Boiler Drains – Brass           | 171–172 |
| Evaporative Cooler Valve        | 176     |
| Evaporative Cooler Float Valves | 176     |
| Float Rods                      | 176     |
| Float Valves                    | 175     |
| Gas Valves                      | 168–170 |

### Filter Driers & Strainers

#### Strainers

|                     |     |
|---------------------|-----|
| Water Strainer      | 180 |
| Inline Y Strainer   | 183 |
| MCC Inline Strainer | 183 |

#### PVC DWV Fittings

|                          |                  |
|--------------------------|------------------|
| Adapter                  | 128–126, 128–131 |
| Bushing                  | 127,130          |
| Cap                      | 129–130          |
| Closet Flange            | 149–152          |
| Coupling                 | 123,130,132      |
| Drum Trap                | 149              |
| Elbows                   | 133–137          |
| Nut                      | 130,132          |
| Pipe Increaser           | 124              |
| Plug                     | 126, 128         |
| P-Trap                   | 148              |
| Return Bend              | 147              |
| Swivel Tray Plug Adapter | 152              |
| Tail Piece Adapter       | 147              |
| Tee                      | 137–142          |
| Trap Adapter             | 154–155          |
| Wye                      | 142–147          |

|                                |         |
|--------------------------------|---------|
| Gate Valves – Brass            | 170     |
| Hose Bibbs – Brass             | 173     |
| Oil Tank Valve                 | 177     |
| Radiator Valves – Brass        | 174     |
| Stop & Waste Valves – Brass    | 171     |
| Swing Check Valves             | 173–174 |
| Tank Floats                    | 175     |
| <b>Specialities</b>            |         |
| Ice Maker Humidifier Kit       | 176     |
| Saddle Tee                     | 176     |
| Pipe Cutter                    | 178     |
| Pipe Cutter Blade, Replacement | 178     |



8285 Tournament Drive, Suite 150 • Memphis, TN 38125

November 2007 HVACR-MLT-105