

# INSTALLATION MANUAL

## DOWNFLOW / HORIZONTAL ELECTRIC FURNACE



### MODELS: WEFC & WEFX SERIES

#### LIST OF SECTIONS

1 – General	1	6 – Line Voltage and Control Box Wiring	8
2 – Safety	3	7 – Thermostat Wiring and Connections	10
3 – Return Air and Clearance Requirements	4	8 – Motor, Blower and Furnace Startup	14
4 – Supply Air and Duct Connector Installation	5	9 – Final System Checkout	15
5 – Furnace Installation	6	10 – Wiring Diagrams	16

#### LIST OF FIGURES

1 – Furnace Dimensions	2	17 – Control Box Power, Blower & Fuse Connections	10
2 – Closet Clearances	4	18 – Separate Thermostats, Same Furnace Wiring Diagram	12
3 – Typical Closet Installations	4	19 – Same T' stat, Separate Furnace - Separate Trans Connections	12
4 – Typical Alcove Installations	5	20 – Same T' stat, Separate Furnace and Cooling Unit Connection	12
5 – Clearance – Access for Service	5	21 – Typical Heating/Cooling Separate Transformer Connections	13
6 – Duct Connector Depths	5	22 – Typical Heat Pump/Heating/Cooling T' Stat Connections	13
7 – Duct Connector and Floor Base Installations	6	23 – X-13 motor Terminals	14
8 – Duct Connector Measurements	6	24 – Blower Assembly and Blower Deck	15
9 – Duct Connector and Floor Base Measurements	6	25 – Wiring Diagram 5 kW w/ X-13 Blower Motor	17
10 – Return Air Grille and Frame Assembly	7	26 – Wiring Diagram 8 kW, 10 kW, 12kW w/ X-13 Blower Motor	18
11 – Grille and Frame Assembly Filter Locations	7	27 – Wiring Diagram 15 kW, 17kW w/ X-13 Blower Motor	19
12 – Coil Cabinet Door Bracket Location	7	28 – Wiring Diagram 20 kW w/ X-13 Blower Motor	20
13 – Control Box Component Locations	9	29 – Wiring Diagram 5 kW w/ PSC Blower Motor	21
14 – Control Box Cover and Circuit Breaker Location	10	30 – Wiring Diagram 8 kW, 10 kW, 12kW w/ PSC Blower Motor	22
15 – Line Voltage Electrical Shield	10	31 – Wiring Diagram 15 kW, 17kW w/ PSC Blower Motor	23
16 – Line Voltage Electrical Shield Location	10	32 – Wiring Diagram 20 kW w/ PSC Blower Motor	24

#### LIST OF TABLES

1 – Electric Furnace Model Specifications	2	8 – Electrical Data	9
2 – Model Nomenclature	2	9 – Low Voltage Wire Gauge and Max Lengths	10
3 – Optional Cooling Cabinets and Return Air Grille	2	10 – Recommended Heat/Cool T' stat Wire Color Code	12
4 – Clearances to Combustibles	4	11 – Recommended Heat/Cool/HP T' stat Color Code	12
5 – Duct Connectors	5	12 – X-13 Motor Terminal Connections	14
6 – Wiring Requirements – Single Branch Circuit	8	13 – X-13 Motor Factory Speed Tap Settings	16
7 – Wiring Requirements – Dual Branch Circuit	9		

### SECTION I: GENERAL

The following list includes important facts and information regarding the electric furnace and its inclusions.

1. Furnace is rated at 240 volts AC at 60 Hertz
2. Furnace is the same size for all models
3. Four-wire thermostat operation for heating and cooling
4. A/C ready furnaces equipped with blower for A/C or Heat Pump operation.
5. Holding Strap furnished with furnace.
6. This furnace is designed for downflow/horizontal application.

7. This furnace must not be operated without furnace door installed.

NOTE: This furnace and its components listed on the A/C and Heat Pump equipment sticker were listed in combination as a system by ETL for the United States.

**SAVE THIS MANUAL FOR FUTURE REFERENCE**

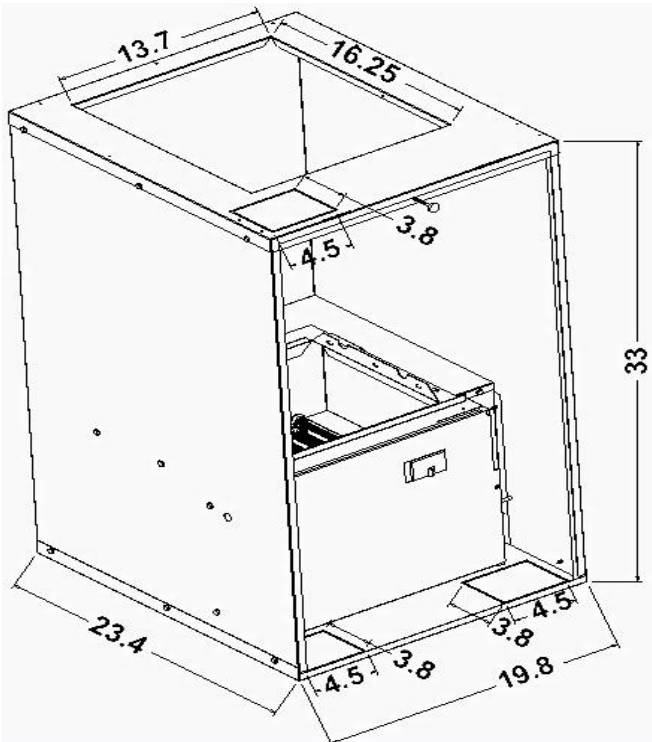

**Figure 1: Furnace Dimensions**

Models	ALL	ALL	ALL	ALL
Input, kW	5	8	10	12
With A-Coil Cabinet	NO	NO	NO	NO
Air Temperature Rise, Range - F	20-80	20-80	30-90	30-90
Designed Max Outlet Air Temp-F	170	170	180	180
Blower-Heat or Heat/Cool	10 X 9 BLOWER			
Max. External SP (Duct), In. W.C.	0.3			
Thermostat Circuit	24 VAC, 60 Hz, 40VA			
Electric Furnace Cabinet Height	33 inches			

Models	ALL	ALL	ALL
Input, kW	15	17	20
With A-Coil Cabinet	NO	NO	NO
Air Temperature Rise, Range - F	35-100	40-100	40-100
Designed Max Outlet Air Temp-F	185	185	185
Blower-Heat or Heat/Cool	10 X 9 BLOWER		
Max. External SP (Duct), In. W.C.	0.3		
Thermostat Circuit	24 VAC, 60 Hz, 40VA		
Electric Furnace Cabinet Height	33 inches		

**Table 1: Electric Furnace Model Specifications**

**Available Blower Motors**

1. Standard Blower Motor – 5 SPD X-13 MOTOR
2. Optional Blower Motor – 3 SPD PSC MOTOR

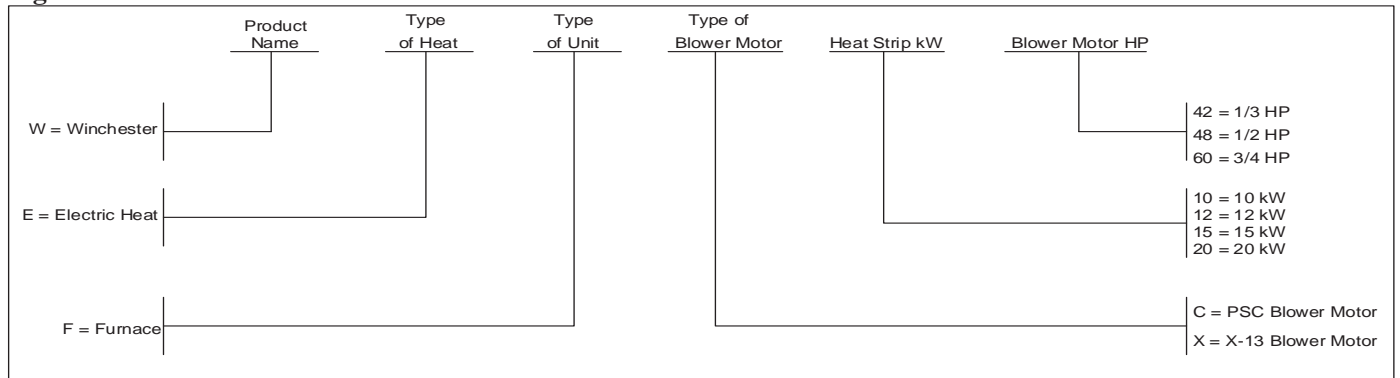

**Table 2: Furnace Model Nomenclature**

Coil Cabinet Model	Front Door of Cabinet	Open Top 17 3/4" x 21 3/4"	Maximum Air Flow CFM	1" Pleated Air Filter, In The Door	2" Pleated Air Filter, Top of Cabinet	Height	Depth	Width	Coil Sizes
97-FLSB-21	Louvered	N/A	1200	20x20		23 1/4"	25"	19 3/4"	All Mortex 96 series coils will fit in cabinet
97-FSOB-21	Solid		1600		20x24	23 1/4"	25"	19 3/4"	
97-FLOB-21	Louvered		1800	20x20	20x24	23 1/4"	25"	19 3/4"	
97-FLSB-27	Louvered	N/A	1600	20x30		30 1/2"	25"	19 3/4"	96-97 series coils and 98 series coils sizes up to 98-8W7
97-FSOB-27	Solid		1600		20x24	30 1/2"	25"	19 3/4"	
97-FLOB-27	Louvered		1800	20x20	20x24	30 1/2"	25"	19 3/4"	
97-FLSB-39	Louvered	N/A	1800	2ea 20x20		40 1/4"	25"	19 3/4"	All Mortex series coils will fit in cabinet
97-FSOB-39	Solid		2000		20x24	40 1/4"	25"	19 3/4"	
97-FG-18	Louvered	N/A	1200	N/A	N/A	18"	N/A	19 3/4"	Frame & Grills Non-Cabinet
97-FG-24	Louvered	N/A	1600	N/A	N/A	24"	N/A	19 3/4"	

**Table 3: Optional Cooling Cabinets and Return Air Grille Frame Assemblies**

## SECTION II: SAFETY



This is a safety alert symbol. When you see this symbol on labels or in manuals; be alert to the potential for personal injury. Understand and pay particular attention to the signal words

### DANGER, WARNING, or CAUTION.

**DANGER:** indicates an **imminently** hazardous situation, which if not avoided, **will result in death or serious injury.**

**WARNING:** indicates a **potentially** hazardous situation, which if not avoided, **could result in death or serious injury.**

**CAUTION:** indicates a **potentially** hazardous situation, which if not avoided, **may result in minor or moderate injury.** It is also used to alert against unsafe practices and hazards involving property damage.

 <b>WARNING</b>
Improper installation may create a condition where the operation of the product could cause personal injury or property damage.
Improper installation, adjustment, alteration, service or maintenance can cause injury or property damage. Refer to this manual for assistance or for additional information consult a qualified contractor, installer, or service agency.

 <b>CAUTION</b>
This product must be installed in strict compliance with the installation instructions and any applicable local, state, and national codes including, but not limited to building, electrical, and mechanical codes.

 <b>WARNING</b>
<b>FIRE OR ELECTRICAL HAZARD</b>
Failure to follow the safety warnings exactly could result in serious injury, death, or property damage. A fire or electrical hazard may result causing property damage, personal injury or loss of life.

### Furnace Weights

WEFXxx42 Models – 82 lbs

WEFXxx48 Models – 79 lbs

WEFXxx60 Models – 85 lbs

### Safety Requirements

1. This electric furnace should be installed in accordance with all national and local; building, safety, plumbing,

- and wastewater codes and requirements; along with all other applicable codes.
2. Refer to the furnace rating plate for the furnace model number.
3. Refer to the dimensions page of this instruction for the duct connector dimensions shown in Figures 6 thru 9. The duct connector must be installed according to the instructions in this manual.
4. Provide clearances from combustible materials as listed under **Clearances to Combustibles.**
5. Provide clearances for servicing ensuring service access is allowed for the control box, electric elements and the blower.
6. Failure to carefully read and follow all instructions in this manual can result in malfunction of the furnace, death, personal injury, and/or property damage.
7. Check the rating plate and the power supply to be sure the electrical characteristics match.
8. Electric furnace shall be installed so the electrical components are protected from water.
9. Installing and servicing heating/cooling equipment can be hazardous due to electrical components.
10. Only trained and qualified personnel should install, repair or service heating/cooling equipment. Untrained service personnel can perform basic maintenance functions such as cleaning of exterior surfaces and replacing the air filters. Observe all precautions in the manuals and on the attached labels when working on this appliance.
11. These instructions cover minimum requirements and conform to existing national standards and safety codes. In some instances these instructions exceed certain local codes and ordinances, especially those who have not kept up with changing mobile home, modular home and HUD construction practices. These instructions are to be followed and are the minimum requirement for a safe installation.

### Inspection

As soon as the furnace is received, it should be inspected for possible damage during transit. If damage is evident, the extent of the damage should be noted on the carrier's freight bill. A separate request for inspection by the carrier's agent should be made in writing. Before installing the furnace you should check the cabinet for screws or bolts which may have loosened in transit. There are no shipping or spacer brackets which need to be removed before startup.

Also check to be sure all accessories such as heater kits, and coils are available. Installation of these accessories should be accomplished before the furnace is set in place or the connecting of the wiring, electric heat, ducts or piping.

### CODES

The furnace must be installed in accordance with the following codes.

- Standard for the Installation of Air Conditioning and Ventilating Systems (NFPA 90A)
- Standard for the Installation of Warm Air Heating and Air Conditioning Systems (NFPA 90B)
- National Electrical Code (NFPA 70)
- Canadian Electrical Code, Part I (CSA C22.1)

- All local codes (State, City, and Township)

NOTE: All applicable codes take precedence over any recommendation made in these instructions.

### SECTION III: RETURN AIR AND CLEARANCE REQUIREMENTS

#### Location

Access for servicing is an important factor in the location of any furnace. Provide a minimum of 24 inches in front of the furnace for access to the control box, heating elements, and

blower. This access may be provided by a closet door or by locating the furnace so that a wall or partition is not less than 24 inches from the front access door.

#### Furnace Clearances

This furnace is approved for zero (0 inches) clearance to combustible material on any part of the furnace exterior and the inlet or outlet ducts. Refer to Table 4 for clearance to combustibles information.

CLEARANCES

MODEL	TOP (in)	BACK (in)	SIDES (in)	FRONT OF FURNACE		DUCT (in)
				ALCOVE (in)	CLOSET (in)	
ALL	6	0	0	18	6	0

Table 4: Clearances to Combustibles

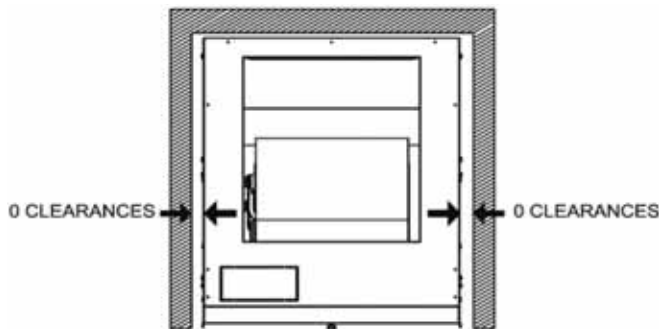

Figure 2: Closet Clearances

#### Return Air

In order for the furnace to work properly, a closet or alcove must have a certain total free area opening for the return air.

#### FOR A/C and HP Furnaces (1/3 HP Blower)

- Minimum 200 in<sup>2</sup> free area opening
- Use Return Grille or Coil Cabinet

#### FOR A/C and HP Furnaces (1/2 HP Blower)

- Minimum 250 in<sup>2</sup> free area opening
- Use Return Grille, A/C Coil Cabinet, or any return grille with a minimum 250 in<sup>2</sup> free area opening

#### FOR A/C and HP Furnaces (3/4 HP Blower)

- Minimum 390 in<sup>2</sup> free area opening
- Use Return Grille, or A/C Coil Cabinet, or any return grille with a minimum 390 in<sup>2</sup> free area opening

#### Top Return Only – Recommended Grille Size

- 800 CFM – 20 X 20 Grille – 324 in<sup>2</sup>
- 1000 CFM – 20 X 25 Grille - 414 in<sup>2</sup>
- 1200 CFM – 25 X 25 Grille - 414 in<sup>2</sup>
- 1400 CFM – 25 X 30 Grille - 644 in<sup>2</sup>
- 1600 CFM – 25 X 30 Grille - 644 in<sup>2</sup>
- 1800 CFM – 30 X 30 Grille - 784 in<sup>2</sup>

#### Louvered Door and Top Return – Recommended Grille Size

- 800 CFM – 10 X 20 Grille – 144 in<sup>2</sup>
- 1000 CFM – 12 X 20 Grille - 180 in<sup>2</sup>
- 1200 CFM – 14 X 20 Grille - 216 in<sup>2</sup>
- 1400 CFM – 18 X 20 Grille - 288 in<sup>2</sup>
- 1600 CFM – 18 X 20 Grille - 288 in<sup>2</sup>
- 1800 CFM – 20 X 20 Grille - 324 in<sup>2</sup>

The return air opening can be located in a closet front door or a side wall above the furnace casing, or in a louvered door on the furnace. If opening for the return air is located in the floor, side walls, or closet door anywhere below the furnace casing height, a 6 inch minimum clearance must be provided on the furnace side where the return is located to provide for proper air flow. The 6 inch minimum clearance is not required if there is a return grille installed above the furnace with the sufficient return air opening.

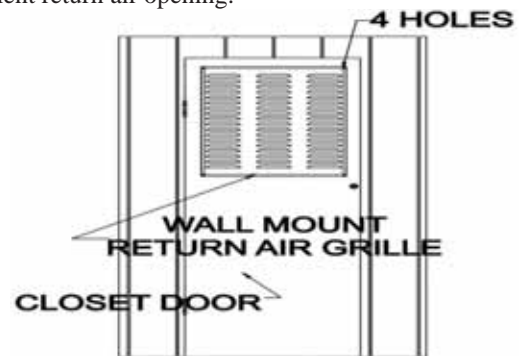

Figure 3: Typical Closet Installations

Provisions shall be made to permit the air in the rooms and the living spaces to return to the furnace. Failure to comply may cause a reduction in the amount of return air available to the blower, causing reduced air flow resulting in improper heating of the living space. The reduced air flow may cause the furnace to cycle on the limit causing premature heating element failure.

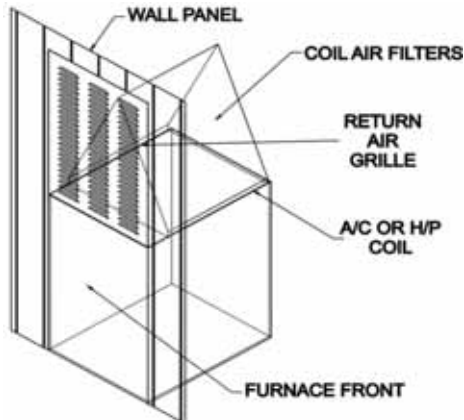

Figure 4: Typical Alcove Installations

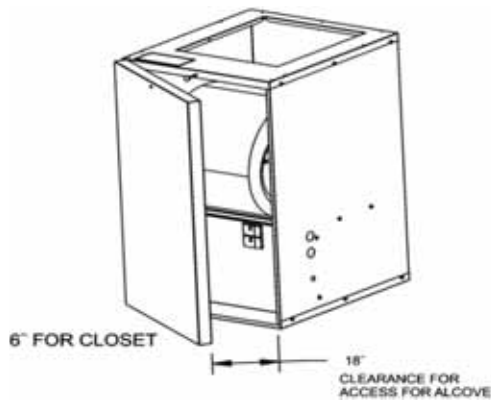

Figure 5: Clearance – Access for Service

**Air Distribution System**

The furnace is designed to operate at a 0.30 inch WC static pressure. In order to assure proper air flow through the furnace the duct distribution system must be designed so that the external static pressure from the furnace, thru the duct system must not exceed 0.30 inch WC. It is recommended you review the manual “**Manufactured Housing Duct Systems Guide to Best Practices**” by Manufactured Housing Research Alliance (MHI-MHRA) before selecting the air distribution system you are going to use.

**SECTION IV: SUPPLY AIR AND DUCT CONNECTOR INSTALLATION**

**Duct Connectors**

**90-DCU0-XX Duct Connectors**

The duct connector is used to provide a sealed connection between the furnace base and an under the floor duct system. The duct connector allows the furnace to be installed on a combustible floor without the use of a separate sub base providing insulation is placed between the duct connector and the combustible floor. Table 5 indicates the duct connector needed for your application.

DEPTH FROM FLOOR TO DUCT	FINGERED STYLE
1"	90-DCU0-01
2"	90-DCU0-01
3"	90-DCU0-01
4"	90-DCU0-01
5"	90-DCU0-02
6"	90-DCU0-02
7"	90-DCU0-02
8"	90-DCU0-02
9"	90-DCU0-03
10"	90-DCU0-03
11"	90-DCU0-03
12"	90-DCU0-03

Table 5: Duct Connectors

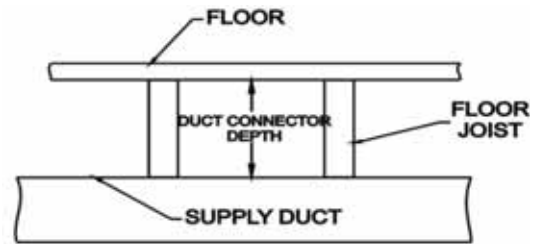

Figure 6: Duct Connector Depths

**⚠ WARNING**

Duct connector can be installed on combustible flooring, **except carpeting**, providing insulation having a rating of R-12 or higher is used between the floor base and the combustible floor.

Failure to use insulation with a rating of R-12 or higher between the floor base and a combustible floor; then installing the floor base on a combustible floor could result in serious injury, death, or property damage.

A fire may result causing property damage, personal injury or loss of life.

**Installing the Duct Connector**

1. Attach the four (seal strip) foam tape gaskets provided with the duct connector alongside the perimeter of the duct opening to seal the duct connector where it attaches to the top of the duct as shown in Figures 7, 8 and 9.
2. Insert the duct connector thru the opening in the floor and attach the duct connector to the top of the duct by inserting the tabs thru the opening in the top of the duct and bending the tabs back 90 degrees against the inside of the duct, so the top of the duct is securely fastened to the duct connector. Be sure the seal strip has sealed the area around the duct connector where it attaches to the duct.
3. Slit the corners of the duct connector that extend above the floor, and then bend the sides over onto the floor surface. Refer to Figures 7, 8 and 9.
4. Place insulation with a rating of R-12 or higher between the floor base and the floor when used on a combustible

floor. Be sure to cut the insulation around the perimeter of the duct connector opening.

5. Install the floor base over the floor opening with the flanges on the 11 x 13 inch opening facing down. Refer to Figures 8 and 9.
6. Locate the four (4) screws provided with the duct connector kit and install the four screws through the four holes provided in the floor base to secure the floor base to the floor.

The duct connector is designed for use on ducts wider than 12" inches. When using the connector on smaller width ducts, there will not be sufficient clearance to bend the tabs on two sides of the duct connector.

In such cases the tabs may be attached to the sides of the duct by using sheet metal screws or other suitable fasteners. Place holes in the tabs for sheet metal screws by drilling the required screw holes in three (3) tabs on each side of the duct connector. If more than three tabs need to be used to provide a more secure and air tight connection, then drill the remaining tabs so the additional tabs can also be fastened to the duct with screws. Use a duct sealer to seal any air leaks between the duct and the duct connector.

Tape can be used to provide a better air seal. The tape should be a type approved by applicable national or local codes.

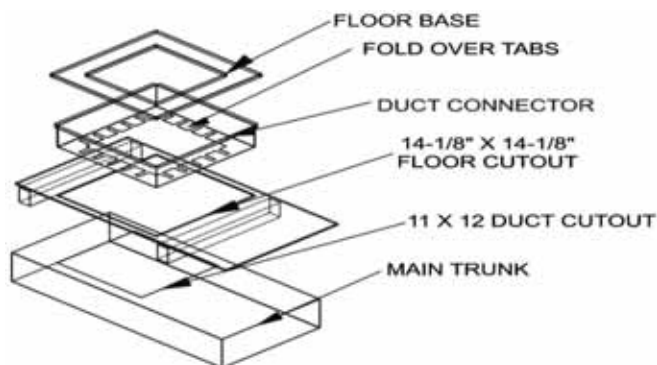

**Figure 7: Duct Connector and Floor Base Installation**

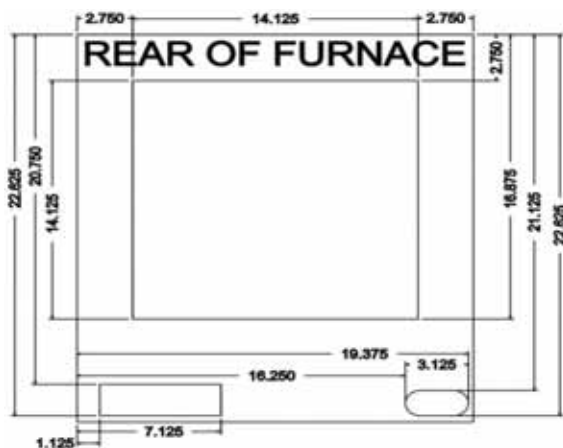

**Figure 8: Duct Connector Measurements**

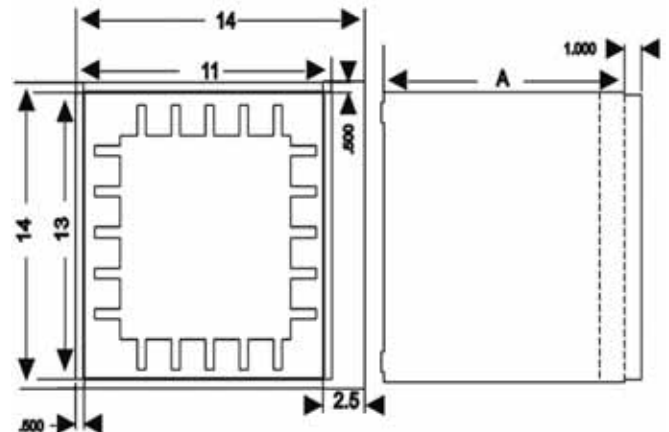

**Figure 9: Duct Connector Installation in the Floor**

## SECTION V: FURNACE INSTALLATION

### Installing the Furnace with a Return Air Grille Frame Assembly

#### Alcove Installation

This kit is approved for use in an alcove – heating only installation without an air conditioning coil. The return air grille frame assembly is available in 18" height and 24" height. To install the return air grille frame assembly to the furnace, follow the steps below:

Prior to installing the furnace make sure the holes are cut into the floor for the refrigerant tubing, the electrical wiring are in place, the thermostat wiring and the condenser control wiring should be in place.

1. Before installing the return air grille frame on the furnace, be sure you have enough clearance to install the furnace and the return air grille assembly.
2. Remove the top shipping cover and corner posts.
3. Remove the front access panel (door).
4. Remove the return air grille frame assembly from the box.
5. Set the return air grille frame assembly on the top – front part of the furnace. Be sure to line up the screw holes in the frame with the screw holes in the furnace top cover as shown in Figure 10.
6. Insert the screws provided with the louvered door assembly through the holes in the louvered door frame and into the holes in the furnace top cover.
7. Tighten the screws to secure the louvered door frame assembly to the top cover of the furnace.
8. Remove the bottom shipping cover.
9. Slide the furnace on to the floor base. Push the furnace back until the furnace casing is against the rear flange.
10. Secure the furnace to the floor by drilling two holes through the furnace base and the floor base at the right and left front inside corners of the cabinet. Use two screws to secure the furnace to the floor.

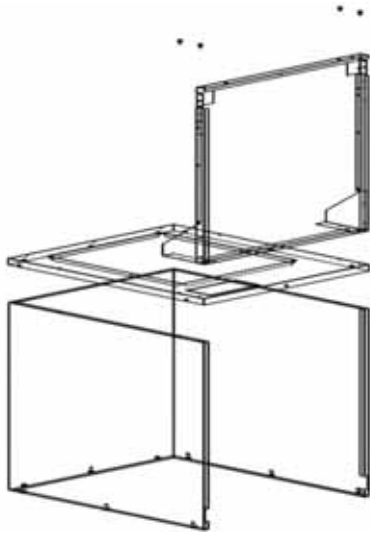

**Figure 10: Return Air Grille Frame Assembly**

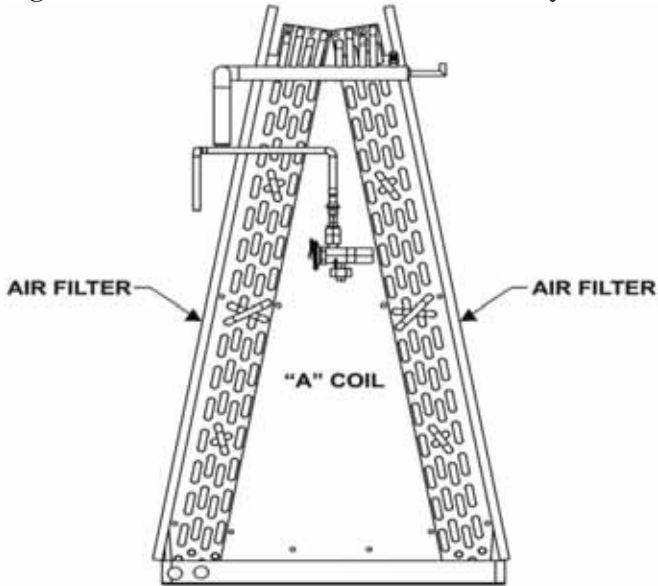

**Figure 11: Return Air Frame Assembly Filter Location**

### Installing the Furnace and Coil Cabinet

#### Closet Installation

This kit is approved for use in an alcove or closet installations with an approved air conditioning coil. The coil cabinets are available in 23.25", 30.50" and 41.25" height. The furnace is 33" in height making the total furnace and coil cabinet heights 56", 63" and 73". To install the coil cabinet assembly to the furnace, follow the steps below:

Prior to installing the furnace make sure the holes are cut into the floor for the refrigerant tubing, the drain line, the electrical wiring, the thermostat wiring and the condenser control wiring.

1. Before installing the coil cabinet on the furnace, be sure you have enough clearance to install the furnace and the filter door assembly.
2. Remove the top shipping cover and corner posts.
3. Remove the bottom shipping cover.
4. Remove the front access panel (door) and lay the furnace on its back.
5. Remove the coil cabinet from the box and assemble per the instructions.
6. Lay the coil cabinet on its back and place the coil cabinet flanges against the furnace top cover.
7. Place coil cabinet door bracket between the coil cabinet flanges and the furnace top as shown in Figure 12.
8. Install the screws through the holes provided in order to secure the cooling coil cabinet to the top of the furnace.
9. Slide the furnace on to the floor base. Push the furnace back until the furnace casing is against the rear flange.
10. Secure the furnace to the floor by drilling two holes through the furnace base and the floor base at the right and left front inside corners of the cabinet. Use two screws to secure the furnace to the floor.

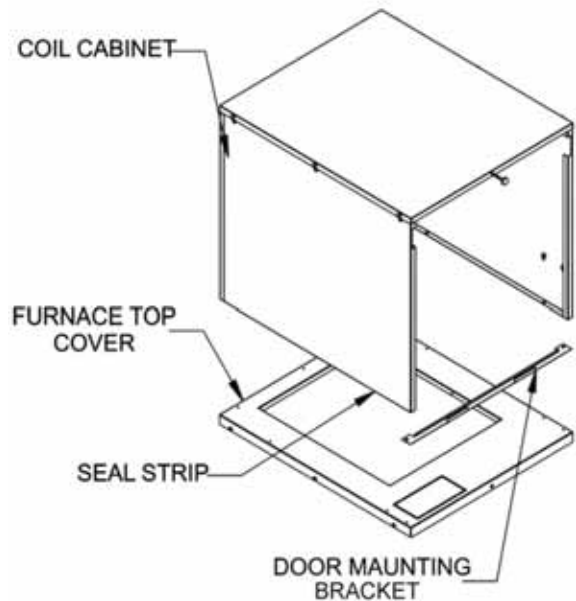

**Figure 12: Coil Cabinet Door Bracket Location**

## SECTION VI: LINE VOLTAGE WIRING

### Power Supply

The furnace internal wiring is complete except for the power supply and the thermostat wires. See wiring diagram and/or Tables 6 and 7 for wire size, fuse/circuit breaker size, and ground wire sizes. The use of cable connectors on incoming power supply wires to relieve any strain on wiring is recommended. Follow the steps below to connect the power supply wires.

#### Single Circuit Line Wiring Connections

1. Remove the control box cover.

2. Install the cable connectors on the 7/8" dia holes on the right side of the control box.
3. Strip 1/2" of the insulation on the end of each wire.
4. Insert the wires through the holes in the casing and through the cable connectors.
5. Insert the black wire into the L1 screw terminal on the 1<sup>st</sup> circuit breaker from the top and tighten the set screw to clamp down on the wire.
6. Insert the white or red wire into the L2 screw terminal on the 1<sup>st</sup> circuit breaker down from the top and tighten the set screw to clamp down on the wire.
7. If you are using a single circuit for a 15kW, 17kW, or 20kW model you will need to install a black jumper wire from the L1 terminal on circuit breaker #1 to the L1 terminal on circuit breaker #2 and a white or red jumper wire from the L2 terminal on circuit breaker #1 to the L2 terminal on circuit breaker #2. Refer to Figure 13 for circuit breaker locations.  
Note: The 100 amp 4 Pole Jumper Bar Assembly part number 68BAE001 can be used in place of the jumper wires.
8. Insert the green wire into the ground lug and tighten the set screw.

**Dual Circuit Line Wiring Connections**

9. If you are using a dual circuit for a 15kW, 17kW, or 20kW model you will need to insert the black wire from the second power supply into the L1 screw terminal on the second circuit breaker down from the top and tighten the set screw to clamp down on the wire.
10. If you are using a dual circuit for a 15kW, 17kW, or 20kW model you will need to insert the white or red wire from the second power supply into the L2 screw terminal on the second circuit breaker down from the top and tighten the set screw to clamp down on the wire.

11. If you are using a dual circuit for a 15kW, 17kW, or 20kW model you will need to insert both green wires into the ground lug and tighten the set screw.
12. Tighten the screws on the cable connectors until the power supply wires are securely fastened to the connector.

**NOTE:** The furnaces are equipped with either one or two circuit breakers. These circuit breakers protect the wiring inside of the furnace in the event of a short circuit. Additionally, these breakers provide a means of disconnecting the power to the unit. The circuit breakers in the furnace are not meant to protect the branch circuit wiring between the furnace and the home's breaker panel. General wire and breaker sizes are shown in Table 7. If sheathed cable is used, refer to NEC National Electrical Code (NFPA 70) or the Canadian Electrical Code, Part I (CSA C22.1) and local codes for additional requirements concerning supply circuit wiring. Electrical data can be found in Tables 6, 7, and 8.

**IMPORTANT -** All installation on field wiring must be rated at 60°C or higher. Please refer to the wiring diagrams on the furnace or this book for more information.

The 15kW, 17kW and 20kW models may be connected to a single or dual branch circuit.

**IMPORTANT -** Refer to the NEC National Electrical Code (NFPA 70) or the Canadian Electrical Code, Part I (CSA C22.1) and local codes for wiring material requirements.

	ELECTRIC HEATER SIZES						
	5 kW	8 kW	10 kW	12 kW	15 kW	17 kW	20 kW
Circuit Load - FLA	25.83	38.33	46.50	55.00	67.33	75.83	88.16
Minimum Wire Size (90°C)	#10	#8	#8	#6	#4	#4	#3
Minimum Wire Size (75°C)	#10	#8	#6	#6	#4	#3	#2
Minimum Wire Size (60°C)	#10	#8	#6	#4	#3	#2	#1
Ground Wire Size	#10	#8	#8	#6	#4	#4	#3
Max Fuse Amps	35	50	60	60	80	90	100

**Table 6: Wiring Requirements – Single Branch Circuit**

- Requires a circuit breaker jumper bar or a jumper wire.
- + Refer to the National Electrical Code Table 250-95 for Non-Sheathed Conductor Ground Wire.

	ELECTRIC HEATER SIZES									
	5 kW	8 kW	10 kW	12 kW	15 kW		17 kW		20 kW	
Circuit Number	1	1	1	1	1	2	1	2	1	2
Circuit Load - FLA	25.83	38.33	46.5	55.0	46.5	20.83	55.0	20.83	46.5	41.66
Minimum Wire Size (90°C)	#10	#8	#8	#6	#8	#10	#6	#10	#8	#8
Minimum Wire Size (75°C)	#10	#8	#6	#6	#6	#10	#6	#10	#6	#6
Minimum Wire Size (60°C)	#10	#8	#6	#4	#6	#10	#4	#10	#6	#6
Ground Wire Size	#10	#8	#8	#6	#8	#10	#6	#10	#8	#8
Max Fuse Amps	35	50	60	60	60	25	60	25	60	50

**Table 7: Wiring Requirements – Dual Branch Circuit**

- Dual power supply for US only.
- + Refer to the National Electrical Code Table 250-95 for Non-Sheathed Conductor Ground Wire.

		ELECTRIC HEATER SIZES									
		5 kW	8 kW	10 kW	12 kW	15 kW		17 kW		20 kW	
Branch Circuit Number		1	1	1	1	1	2	1	2	1	2
240 VAC, 60 HZ, 1 PH	BTU	17,033	27,263	34,067	40,946.0	34,067	17,033	40,946	17,033	34,067	34,067
	kW	4.99	7.99	10	12.0	10	4.99	12.0	4.99	10	10
230 VAC, 60 HZ, 1 PH	BTU	15,876	26,512	33,686	38,612	33,686	15,876	38,612	15,876	33,686	33,686
	kW	4.65	7.77	9.78	11.32	9.78	4.65	11.32	4.65	9.78	9.78
220 VAC, 60 HZ, 1 PH	BTU	14,736	23,339	30,222	36,483	30,222	14,736	36,483	14,736	30,222	30,222
	kW	4.32	6.84	8.86	10.69	8.86	4.32	10.69	4.32	8.86	8.86
Heating Element Capacity	BTU	17,033	27,263	34,067	40,946	51,149		57,979		68,232	
	kW	4.99	7.99	9.998	12	14.9904		16.992		19.9968	
Blower Motor @ 240 VAC	AMPS	4.3	4.3	4.3	4.3	4.3	N/A	4.3	N/A	4.3	N/A
	kW	1.032	1.032	1.032	1.032	1.032	N/A	1.032	N/A	1.032	N/A

**Table 8: Electrical Data**

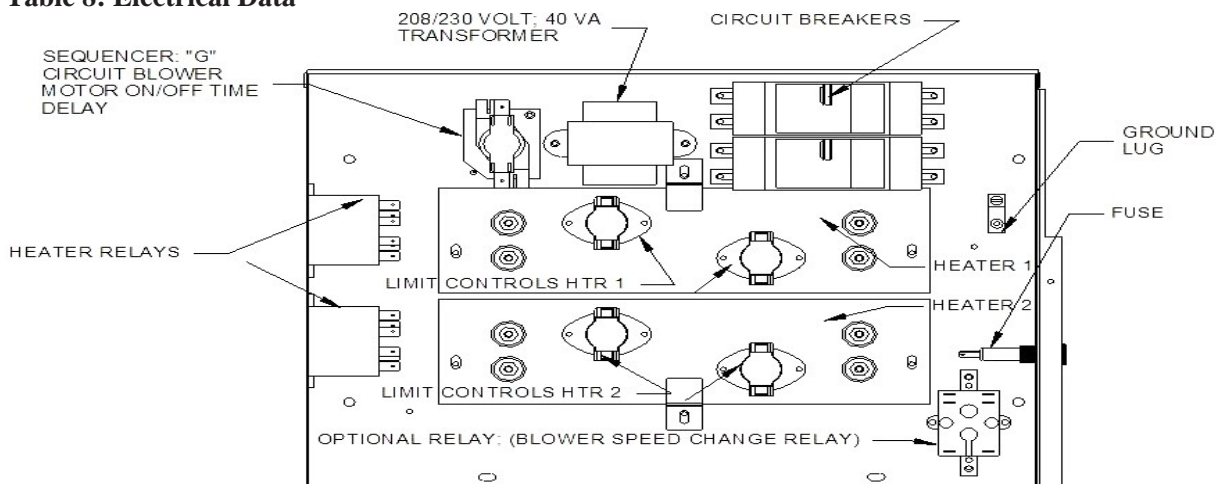

**Figure 13: Control Box Component Locations**

Casing or cabinet must be permanently grounded in accordance with the National Electrical Code or other applicable codes.

Note: **Optional blower speed change relay** is also used as the **isolation relay** for the **PSC motor**. This relay is **not** optional relay on the PSC Motors.

**▲ WARNING**

For personal safety be sure to turn the electrical power “OFF” at the main entrance (Home Circuit Breaker Box) and at the control box circuit breakers before attempting any service or maintenance operations. Homeowners should never attempt to perform any maintenance which requires opening the furnace control box door. Refer to Figure 20.

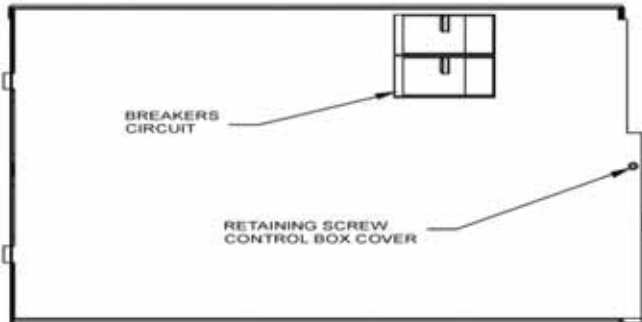

**Figure 14: Control Box Cover and Circuit Breaker Location – Dual Element Box**

**▲ WARNING**

This furnace is equipped with a shield that covers the line voltage electrical supply wires and the circuit breaker connections to prevent accidental electrical shock. Be sure to turn the electrical power “OFF” at the main entrance (Home Circuit Breaker Box) and at the control box circuit breakers before removing the shield. “Refer to Figure 21.

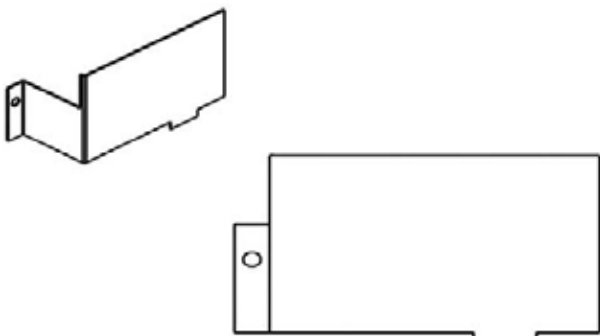

**Figure 15: Line Voltage Electrical Shield**

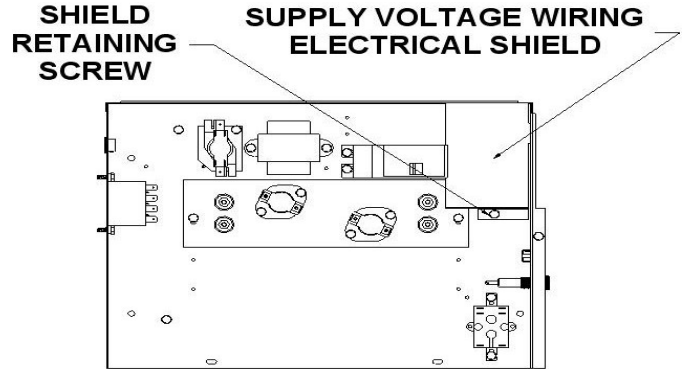

**Figure 16: Line Voltage Electrical Shield Location**

## SECTION VII: THERMOSTAT WIRING AND CONNECTIONS

### Thermostat Wiring

Thermostat wires connect through side of furnace and should also be no smaller than 20 gauge wire. Refer to Table 9 for recommended wire gauge, lengths and maximum current for each wire gauge.

Thermostat Wire Length	Thermostat Wire Gauge	Thermostat Wire Maximum Current
0 - 70 Feet	20	1.5 amps
0 - 120 Feet	18	2.3 amps

**Table 9: Low Voltage Wire Gauge and Max Lengths**

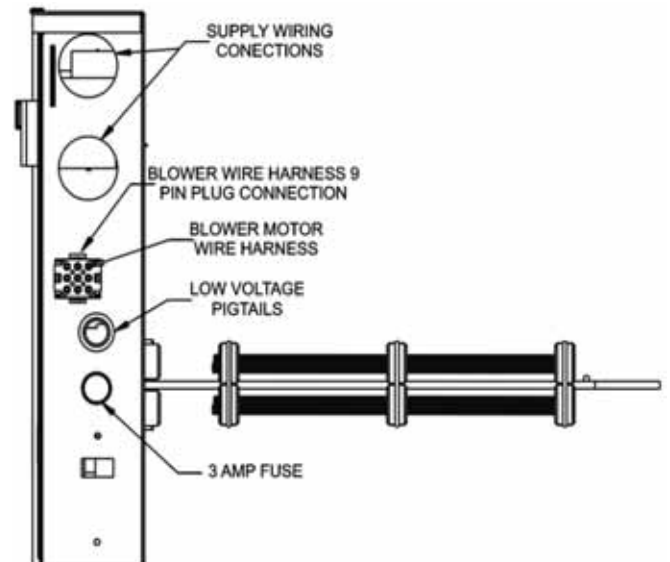

**Figure 17: Control Box In-coming Power, Low Voltage Wiring, Blower Wiring, and Low Voltage Fuse Locations**

Power wires can enter through the side of the unit or through the auxiliary entrance, located in the bottom of the unit. When bringing wiring through the bottom of the furnace, cable connectors must be installed to hold wiring in place and to relieve any strain on the wiring.

These connectors will also serve as a seal between the furnace and the floor. Thus, additional sealing is not required. The use of a five-conductor cable from the thermostat to the furnace is recommended for typical heating or heating / cooling installations with a three-conductor cable from the furnace to the condenser.

A seven-conductor cable from the thermostat to the furnace is recommended for a typical heat pump installation with a five-conductor cable from the furnace to the condenser.

The thermostat wire colors and the typical heating / cooling connections are listed in Table 10.

The thermostat wire colors and the typical heat pump heating / cooling connections are listed in Table 11.

**NOTE:** There is a 3 Amp slow blow bar fuse located on the right side of the control box that protects the 24 VAC circuit. Replace this fuse only with the equivalent 3 Amp fuse.

**NOTE:** If the thermostat cable is on the left side of the furnace place the grommet in the 3/8" hole on the left side of the furnace casing. Run the thermostat wire cable through the control box exiting the right side of the control box next to the low voltage pigtailed. Follow the steps for "**Typical Heating / Cooling Thermostat Wiring Connections**" or "**Typical Heat Pump - Heating / Cooling Thermostat Wiring Connections**"

#### **Thermostat Installation**

The adjustable heat anticipator in the thermostat is pre-set at 0.4 Amps. This setting should be checked at the time of installation.

In some cases the thermostat may be a "self-setting" type in which case no Amp setting will be found on the thermostat, eliminating the need for any field adjustment.

Thermostat should be located on an inside wall in an open area to more closely regulate average room air, preferably, where there is air movement back to furnace. Locating height of thermostat is important. Thermostat should be located preferably in a hall way upstream from the furnace return airflow, not within 3 feet of from any windows and 52 to 66 inches above the floor.

**DO NOT** place the thermostat within three feet of any the furnace supply air registers

**DO NOT** place the thermostat within three feet of any the air conditioner supply air registers

Maintenance, operating and/or programming instructions are in the envelope accompanying the thermostat. Give the envelope to the homeowner.



Do not locate thermostat within three feet of any of the following items:

1. Furnace supply air registers
2. Cooling unit supply air registers
3. Lights or heat lamps
4. Aquariums
5. Televisions, stereo, amplifiers, surround sound systems
6. Stoves or any cooking appliance
7. Refrigerator
8. Washer and/or dryer
9. Hot water tank
10. Sink or near any hot water
11. Within 15 feet of any electric space heater
12. Within 2 feet of any sunlight

#### **Separate Heating and Cooling System; Same Thermostat**

If the furnace and the cooling unit have separate transformers be sure to use a thermostat with isolated heating and cooling contacts to prevent interconnection of Class II 24 Volt Systems. Cycle furnace and the air conditioner separately to make sure it will operate correctly.

Most new thermostats have a separate heating and cooling contact for use with homes that have a furnace and air conditioner that are completely separate and each have a 24 VAC transformer for system control. These thermostats have a "RC" terminal for cooling and a "RH" terminal for heating. Use these terminals to connect cooling unit (RC and Yellow) and the furnace (RH and White) for separate operation. Refer to Figure 21 and 22.

If your thermostat does not have the "RC" and "RH" terminals it is recommended that you purchase a new thermostat.

#### **Separate Heating and Cooling Thermostats**

If the heating/cooling system in your house is a central heating and cooling system but the furnace and the cooling unit are controlled by separate thermostats then the use of a thermostat interlock switch is required in order to prevent the furnace and the air conditioner from operating at the same time.

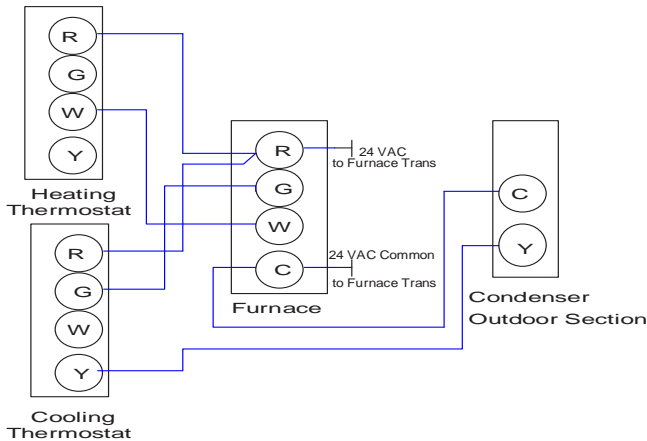

**Figure 18: Separate Thermostats; Same Furnace and Cooling Unit**

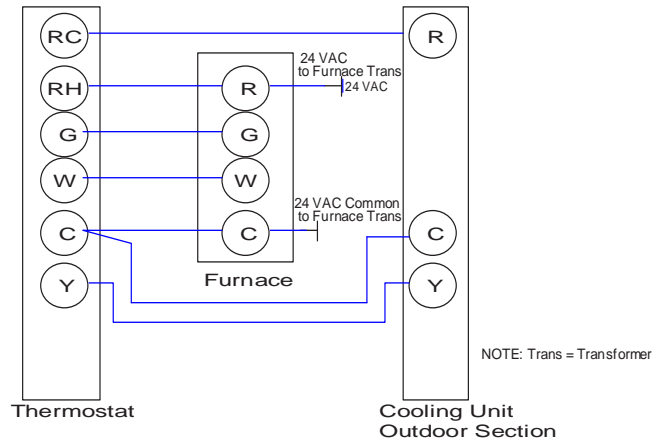

**Figure 20: Same Thermostat; Separate Furnace and Cooling Units with separate transformers**

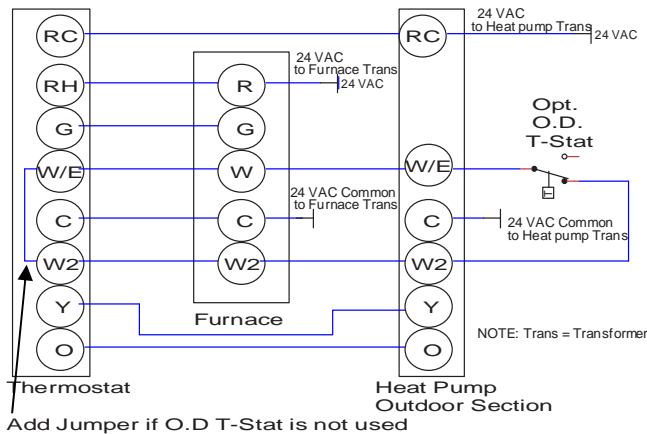

**Figure 19: Same Thermostat; Separate Furnace and Heat Pump Units with separate transformers**

**CAUTION**

When using separate thermostats a thermostat interlock system must be provided to prevent simultaneous operation of the furnace and air conditioner. Simultaneous operation can result in equipment overheating, equipment damage, and energy wastes.

**Do Not** connect the Yellow wire to the thermostat unless an outdoor unit is installed.

Wire Color	Description	Letter Code	Furnace Pig Tail Wire Connection	Thermostat Connection	Condenser Connections
RED	24 VAC	R	Red	R	N/A
WHITE	Heat (1st Stage Heat)	W	White	W or W1	N/A
GREEN	Indoor Fan	G	Green	G	N/A
YELLOW	Cooling - Stage 1	Y	Yellow	Y or Y1	Y or Y1
BROWN	24 VAC Common	BRN	Brown	C	C

**Table 10: Recommended Heating/Cooling Thermostat Wire Color Codes and Connections.**

Wire Color	Description	Letter Code	Furnace Pig Tail Wire Connection	Thermostat Connection	Condenser Connections
RED	24 VAC	R	Red	R	N/A
WHITE	Heat (1st Stage Heat)	W	White	E	N/A
GREEN	Indoor Fan	G	Green	G	N/A
YELLOW	Cooling - Stage 1	Y	Yellow	Y or Y1	Y or Y1
BROWN	24 VAC Common	BRN	Brown	C	C
BLACK	Heat (Optional 2nd Stage Heat)	BLK	White	W2	N/A
ORANGE	Heat Pump Reversing Valve Solenoid	O	N/A	O	O
BLUE	Cooling - (Optional 2nd Stage Cooling)	BLU	N/A	Y2	Y2

**Table 11: Recommended Heating/Cooling/Heat Pump Thermostat Wire Color Codes and Connections.**

**Typical Heating/Cooling Thermostat Wiring Connections**

1. Remove the control box cover.

2. Install a grommet in the 3/8" hole on the right side of the furnace casing to protect the thermostat wire cable.
3. Strip 1/2" of the insulation on the end of each wire.
4. Insert the wire cable from the thermostat through the grommet in the right side of the casing and place the thermostat wire cable on the right side of the control box, next to the low voltage pigtails.
5. Connect the Red (24 VAC) supply thermostat wire to the Red low voltage pigtail wire and secure with a wire nut.
6. Connect the White (heating) thermostat wire to the White low voltage pigtail wire and secure with a wire nut.
7. Connect the Green (indoor fan) thermostat wire to the Green low voltage pigtail wire and secure with a wire nut.
8. Connect the Yellow (air conditioning) wire from the thermostat with the Yellow low voltage pigtail wire on the furnace and with the Red wire from the compressor contactor on the condenser unit. Fasten the three wires together securely with a wire nut.
9. Connect the Brown (24 VAC Common) wire from the thermostat with the Brown low voltage pigtail wire on the furnace and with the Brown (Common) wire from the compressor contactor on the outdoor unit. Fasten the three wires together securely with a wire nut.

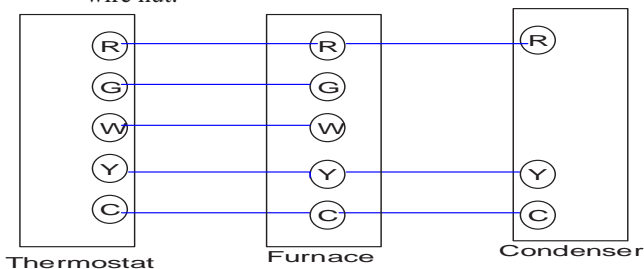

**Figure 21: Typical Heating/Cooling Digital Thermostat Connections**

#### Typical Heat Pump - Heating/Cooling Thermostat Wiring Connections

1. Remove the control box cover.
2. Install a grommet in the 3/8" dia hole on the right side of the furnace casing to protect the thermostat wire cable.
3. Strip 1/2" of the insulation on the end of each wire.
4. Insert the wire cable from the thermostat through the grommet in the right side of the casing and place the thermostat wire cable on the right side of the control box, next to the low voltage pigtails.
5. Connect the Red (24 VAC) supply wire from the thermostat to the Red low voltage pigtail wire on the furnace and with the Red wire from the "R" terminal on the outdoor unit. Fasten the three wires together securely with a wire nut.

**NOTE:** If the cooling unit is separate from the furnace and each have a transformer then remove the Red jumper

6. Connect the White (heating) wire from the thermostat to the White low voltage pigtail wire on the furnace and with the White wire from the "E" terminal on the outdoor unit. Fasten the three wires together securely with a wire nut.
7. Connect the Green (indoor fan) wire from the thermostat to the Green low voltage pigtail wire on the furnace and securely fasten the two wires together with a wire nut.
8. Connect the Red wire from the "Y" terminal on the outdoor unit. Fasten the three wires together securely with a wire nut.
9. Connect the (24 VAC Common) wire from the thermostat with the Brown low voltage pigtail wire on the furnace and with the Brown (Common) wire from the "C" terminal on the outdoor unit. Fasten the three wires together securely with a wire nut.
10. Connect the Orange (Reversing Valve Solenoid) wire from the thermostat with the Orange wire from the "O" terminal on the condenser unit. Fasten the two wires together securely with a wire nut.
11. Connect the Black (2<sup>nd</sup> Stage Heating) wire from the thermostat with the Black wire from the "W2" terminal on the outdoor unit. Fasten the three wires together securely with a wire nut.

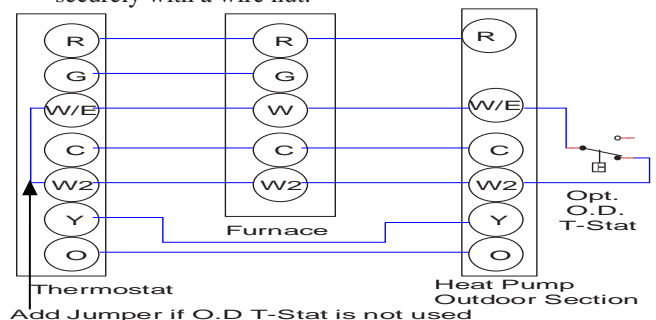

**Figure 22: Typical Heat Pump – Heating / Cooling**

## SECTION VIII: MOTOR, BLOWER AND FURNACE STARTUP SECTION

### WARNING

To avoid personal injury or property damage, make certain that the motor leads cannot come into contact with non-insulated metal components of the unit.

### Selecting the X-13 Blower Speed

This furnace uses the new X-13 high efficiency motor. This motor operates on 240 VAC. The motor speed tap are 24 VAC, 0.03 amps, 60 Hz, 1 PH. The speed taps can be changed by removing the black wire from the sequencer terminal or the red wire from the relay terminal and connecting either the blue, orange, or purple wire to the terminal. Table 12 shows the X-13 motor lead connection labeling and the connection definitions.

Terminal	Connection
C	Speed Tap Common - 24 VAC Common
L	Supply Voltage to Motor - 240 VAC Line 1
G	Ground Connection
N	Supply Voltage to Motor - 240 VAC Line 2
1	Low Speed Tap - 24 VAC
2	Med-Low Speed Tap - 24 VAC
3	Medium Speed Tap - 24 VAC
4	Med-High Speed Tap - 24 VAC
5	High Speed Tap - 24 VAC

**Table 12: X-13 Motor Terminal Connections**

Total 24 VAC circuit amps are 0.14 amps.

### Change Motor Speeds

1. Turn off **all** electrical supply circuits to the furnace at the main service (House Circuit Breaker) panel.
2. Remove furnace front door and switch furnace circuit breaker(s) to "OFF".
3. Disconnect the wire from the sequencer or relay terminal and reconnect the desired wire to the terminal. Refer to Table 12 for speed tap wire colors.
4. Turn the circuit breakers on and reinstall furnace front door.
5. Turn on **all** electrical supply circuits to the furnace at the main service (House Circuit Breaker) panel.

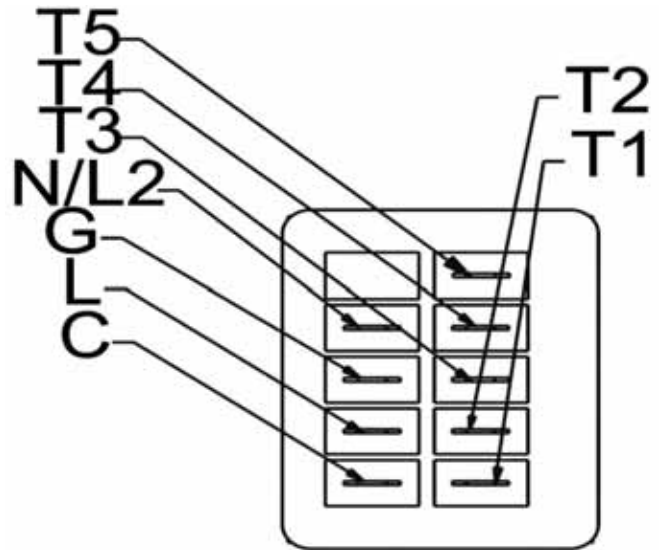

**Figure 23: X-13 Motor Terminals**

### Replacing the Blower Motor

1. Turn off all electrical supply circuits to the furnace at the main service panel.
2. Remove furnace front door and switch furnace circuit breaker(s) to "OFF".
3. Disconnect the plastic wire plug that has the wires that go to the motor terminals from the right side of the control box.
4. Remove the screw on the right side of the blower mounting plate.
5. Slide the blower out of the blower compartment and set on the floor.
6. Remove the wires from the terminals. Be sure to write down the motor terminal identifier and wire color so the wires do not get mistakenly placed on the wrong terminals.
7. Remove the blower motor from the mounting bracket by removing the screws on the sides of the blower that secure the blower to the bracket.
8. Insert the new blower motor into the blower mounting bracket and insert the screws.
9. Connect the wires to the same terminals on this motor that they were connected to on the motor that was removed.
10. Slide the blower assembly into the blower deck and insert the screw on the right side of the mounting bracket.
11. Connect the pin plug to the mating pin plug on the right side of the control box.
12. Switch the circuit breakers to ON and replace furnace front door.
13. Turn on all electrical supply circuits to the furnace at the main service (House Circuit Breaker) panel.
14. Set the thermostat to the desired temperature.

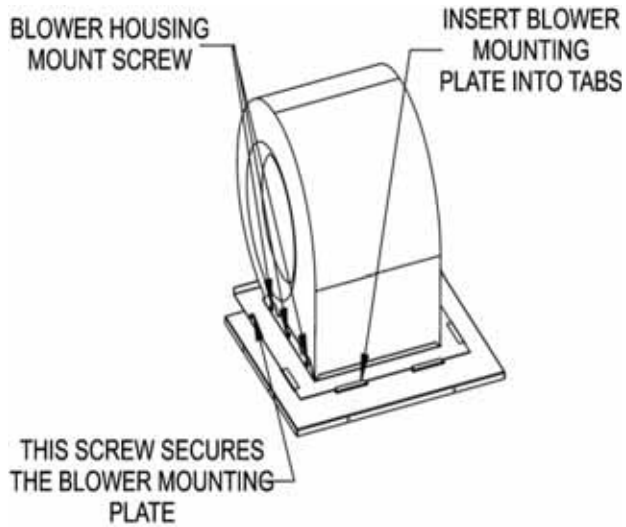

**Figure 24: Blower Assembly and Blower Deck**

## SECTION IX: FINAL SYSTEM CHECKOUT

1. Refer to appropriate wiring diagram and recheck all wiring connections. Ensure that all wiring connections are tight.
2. Check blower motor connectors for proper connection.

3. If the control box cover is removed; reinstall control box cover.
4. Switch circuit breaker(s) to "ON" position.
5. Switch the furnace circuit breakers in the main service (House Circuit Breaker) panel to the ON position.
6. Set the blower selector switch to the ON position and check all of the duct connections for air leaks. Seal any leaks found.
7. Set the blower selector switch to the AUTO position.
8. Set the thermostat above the room temperature to check for proper operation of the electric heaters.
9. Set the thermostat to the desired temperature.

### Thermostat Heat Anticipator

Some thermostats have a heat anticipator setting that must be set to the settings shown below in order to function correctly. If the heat anticipator setting is too low the furnace will short cycle. If the heat anticipator setting is too high the furnace will run long cycles thus causing the temperature to over run the temperature setting. This will cause the homeowner to feel hot by the time the blower completes its cycle; then cold, by the time the furnace cycles on again.

The heat anticipator should be set to the following settings.  
 For 5kW, 8kW, 10kW, 12kW 15kW, 17kW and 20 kW  
 Models Set at 0.4

### Factory Speed Tap Settings @ .3 ESP with Filter and Coil

Series Model	Sp Tap	Nom-Tons	CFM	Coil Range (See Coil Face Velocity Chart Below)	Max kW	Blower Setting
WEFCx48	Low	2.0-2.5	950	96-Series, 97-Series, 98-Series	12	Factory Setting High
	Med	2.5-3.0	1100		15	
	High	3.0-3.5	1400		20	
WEFXx42	T-1	1.5	580	96-Series, 97-Series, 98-Series	5	Factory Setting T-5
	T-2	2.0	750		8	
	T-3	2.5	925		8	
	T-4	3.0	1120		10	
	T-5	3.5	1300		12	
WEFXx48	T-1	2.0	800	96-Series (Do Not use T-5 w/96-), 97-Series, 98-Series	12	Factory Setting T-4
	T-2	2.5	950		15	
	T-3	3.0	1120		15	
	T-4	3.5	1260		17	
	T-5	4.0	1380		20	
WEFXx60	T-1	3.0	1080	98-Series only	17	Factory Setting T-3
	T-2	3.5	1300		20	
	T-3	4.0	1440		20	
	T-4	4.0	1520		20	
	T-5	5.0	1680		20	
<p>WEFC48**** 1/2 HP PSC Motor                      WEFX42**** 1/3 HP X-13 Motor                      WEFX48**** 1/2 HP X-13 Motor                      WEFX60**** 3/4 HP X-13 Motor                      (+) Metering device, Piston, TXV                      (++) Refrigerant Connection, 0P, 2P, 3P, 4P or 6P                      xxx Designates Kilowatts, 015 = 15kW                      CFM Shown with Dry Coil and Filter in place, Wet Coil Correction 4-6%</p>						
<p>Electric Furnace temperature rise (TR) can be used to determine air flow delivered. This result can then be used to determine FPM velocity across the coil face area using the chart below. Set Furnace (Isolate the Heat Pump, just operate the Furnace) to run all the heater strips and then check return air and supply air temperature. Make sure all strips are operating. The difference is the TR</p> <p style="text-align: center;"><b>CFM = (kW x 3412) x (Voltage Correction Less Than 240V) x 1.08 / TR</b></p> <p style="text-align: center;">Example: CFM = (15kW x 3412) x .96 x 1.08 / 56 TR = 51180 x .96 x 1.08 / 56 = 948 CFM</p> <p style="text-align: center;">.96 = 230 Volts .92 = 220 Volts .87 = 208 Volts</p>						
<h3>Coil Face Velocity Formula &amp; Maximum Allowances when using the X-13 Motor</h3>						
Coil Series	CFM	Face Area	Nominal FPM	Coil Models (See Note Below)	Max FPM	Note
96-Series	750	3.11	242	96-(Z,5,G,8,W)2(+)-(++)P	300	<p><b>WARNING</b>                      Exceeding these nominal and / or maximum allowances may cause water blow off from the coil, which; may damage furnace, void furnace warranty and limit liability from those damages</p>
	925	3.32	279	96-(R,M)2,3,4)4(+)-(++)P	300	
	1120	3.56	315	96-(Z,2,3,4,5,G,8,W)(3,5)(+)-(++)P	320	
	1300	4.06	321	96-(R,M)(Z,2,3,4,5,G,8,W)(4,6)(+)-(++)P	325	
97-Series	1380	4.44	311	97-(R,M)(Z,2,3,4,5,G,8,W)(5,7)(+)-(++)P	325	
	1440	5.33	270	98-(R,M)(Z,2,3,4,5,G,8,W)(7,10)(+)-(++)P	330	
	1520	5.78	263	98-(R,M)(Z,2,3,4,5,G,8,W)(8,11)(+)-(++)P	330	
	1520	6.22	245	98-(R,M)(Z,2,3,4,5,G,8,W)(9,12)(+)-(++)P	330	
98-Series	1680	6.67	252	98-(R,M)(Z,2,3,4,5,G,8,W)(10,13)(+)-(++)P	330	
	1680	7.11	237	98-(R,M)(Z,2,3,4,5,G,8,W)(11,14)(+)-(++)P	330	
	1680	7.56	223	98-(R,M)(Z,2,3,4,5,G,8,W)(12,15)(+)-(++)P	330	
	1680	8.00	210	98-(R,M)(Z,2,3,4,5,G,8,W)(13,17)(+)-(++)P (See Example)	330	
<p><b>Air Velocity Formula: CFM / Coil Face Area = Air FPM.</b>                      Example of Coil Complete Model # 98-8G13Y-0P.</p>						
<p><b>Note:</b> When setting up the speed tap on the WEFX furnaces with the X-13 motor the coil face area must be taken into account so as not to exceed 330 Feet Per Minute of air across the coil. Anything higher will blow water off the coil and will be the responsibility of the installing contractor.</p>						

Table 13: X-13 Motor Factory Speed Tap Settings



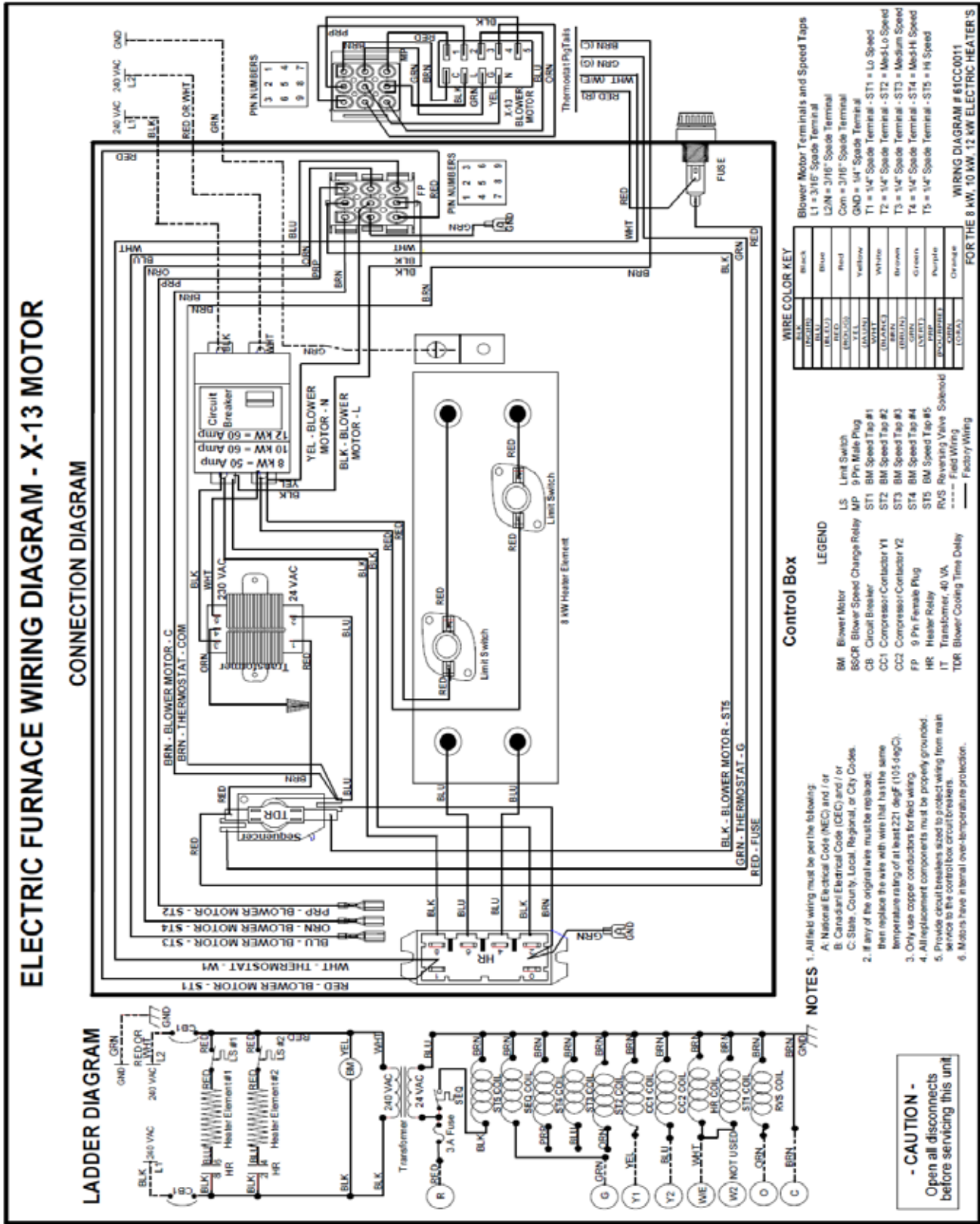

Figure 26: 8 kW / 10 kW / 12 kW Electric Heater Wiring Diagram with a Standard Digital Heating/Cooling/Heat Pump/Single or Two Stage Programmable Thermostat, X-13 blower motor.

**NOTE:** IF ANY OF THE ORIGINAL WIRE SUPPLIED WITH THIS UNIT MUST BE REPLACED. IT MUST BE REPLACED WITH TYPE 105°C THERMOPLASTIC OR THE EQUIVALENT.

# ELECTRIC FURNACE WIRING DIAGRAM - X-13 MOTOR CONNECTION DIAGRAM

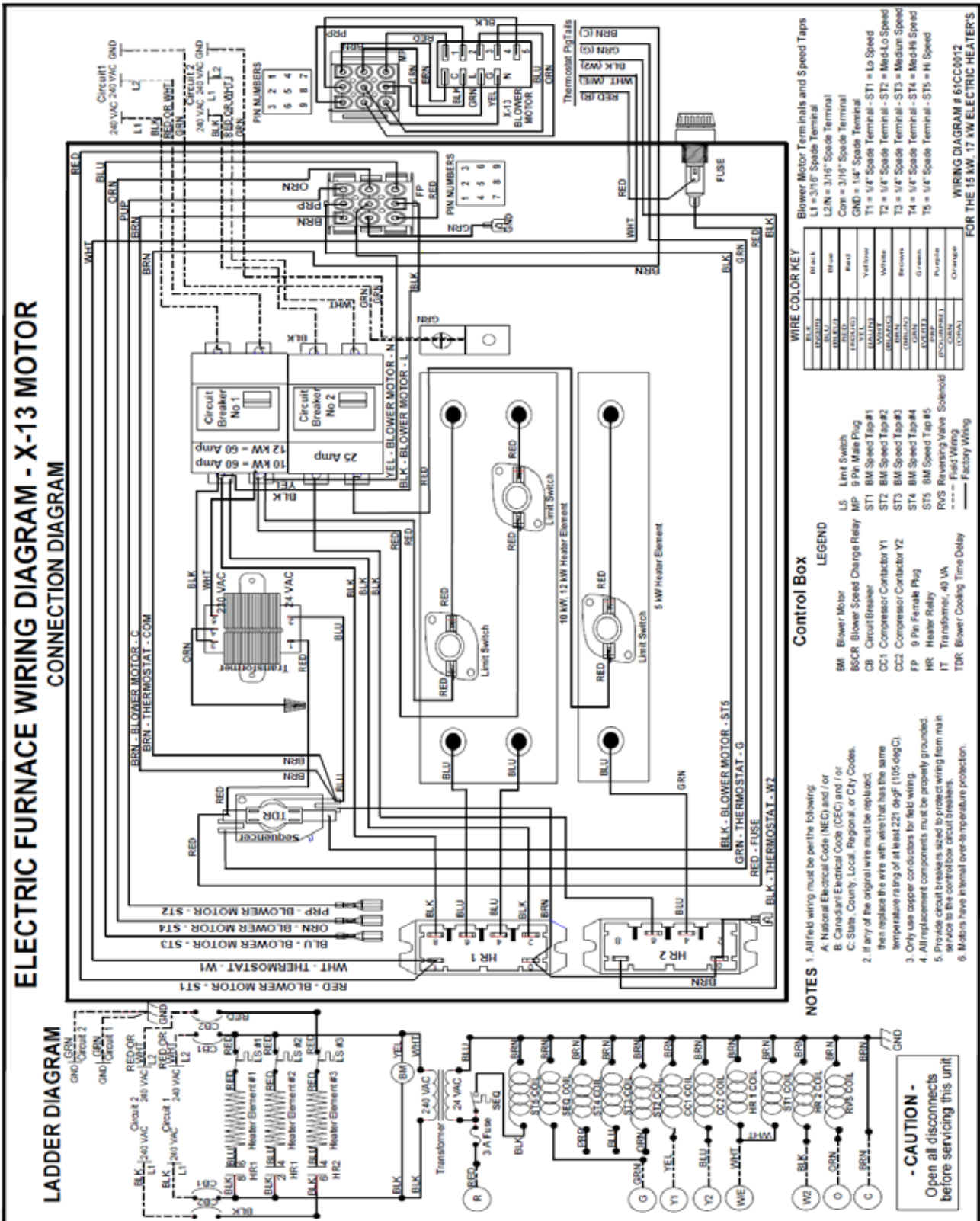

Figure 27: 15 kW / 17 kW Electric Heater Wiring Diagram with a Standard Digital Heating/Cooling/Heat Pump/Single or Two stage Programmable Thermostat, X-13 blower motor.

**NOTE:** IF ANY OF THE ORIGINAL WIRE SUPPLIED WITH THIS UNIT MUST BE REPLACED. IT MUST BE REPLACED WITH TYPE 105°C THERMOPLASTIC OR THE EQUIVALENT.



# ELECTRIC FURNACE WIRING DIAGRAM - PSC MOTOR

## CONNECTION DIAGRAM

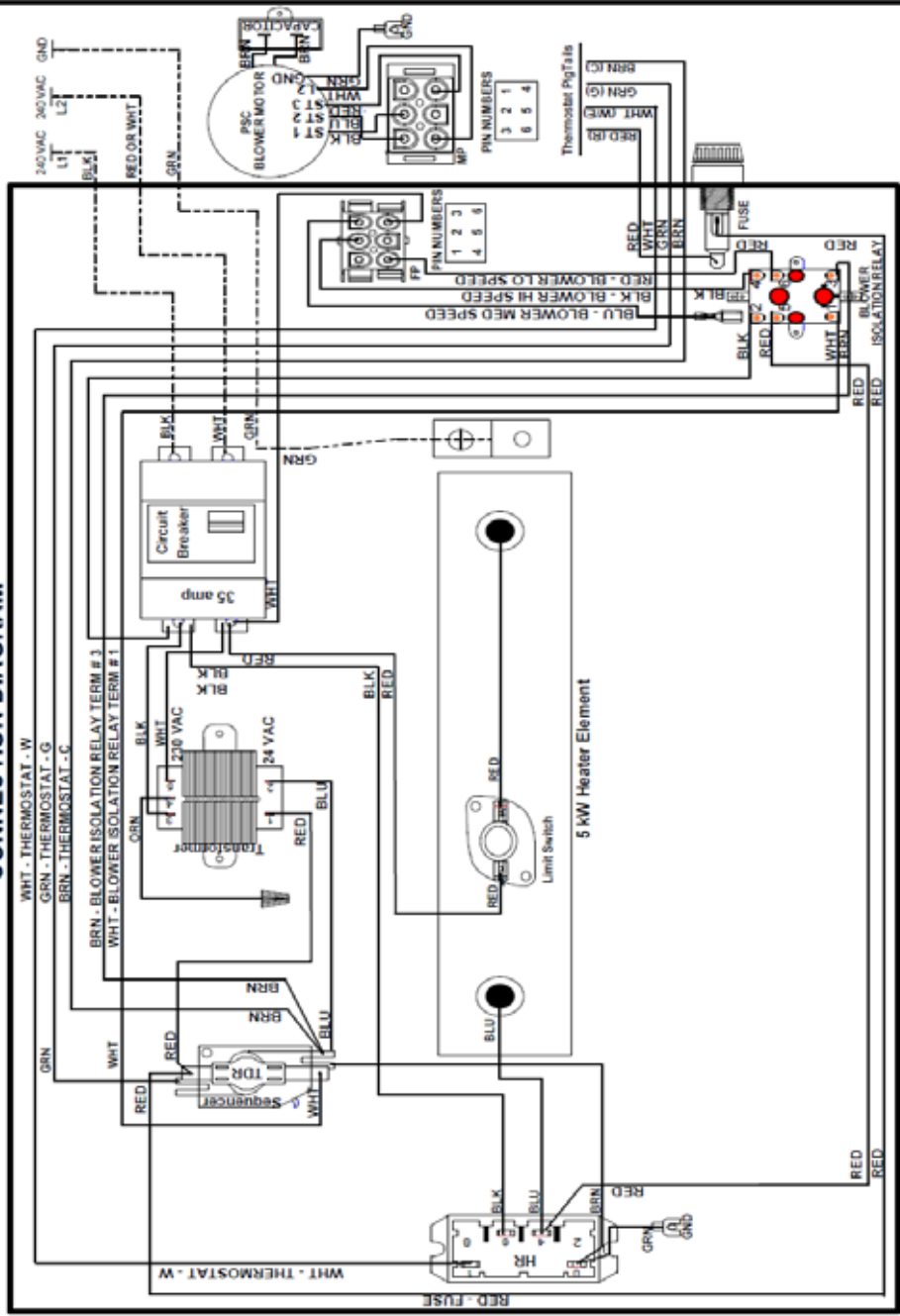

## LADDER DIAGRAM

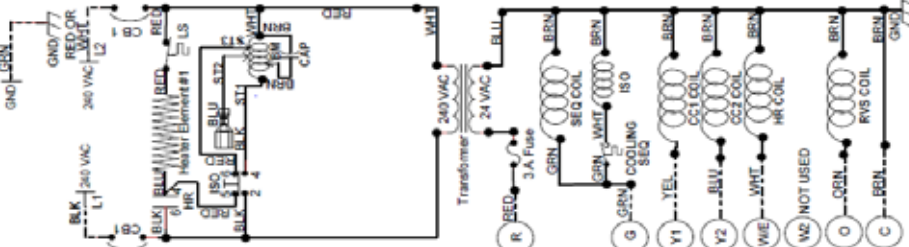

**Blower Motor Terminals and Speed Taps**

L1	= 1/4" Spade Terminal
L2	= 1/4" Spade Terminal
GND	= # 8 Ring Terminal
T1	= 1/4" Spade Terminal - ST1 = Hi-Speed
T2	= 1/4" Spade Terminal - ST2 = Medium Speed
T3	= 1/4" Spade Terminal - ST3 = Lo Speed

**WIRE COLOR KEY**

WIRE COLOR	BACK
BLACK	BLACK
BLU	Blue
BRN	Brown
GRN	Green
ORN	Orange
RED	Red
YEL	Yellow
WHT	White
BLK	Black
BLU	Blue
BRN	Brown
GRN	Green
ORN	Orange
RED	Red
YEL	Yellow
WHT	White

**LEGEND**

BM	Blower Motor
BLSR	Blower Speed Change Relay
CAP	Capacitor
CB	Circuit Breaker
CC1	Compressor Contactor Y1
CC2	Compressor Contactor Y2
FP	9 Pin Female Plug
ST1	Blower Speed Tap #1
ST2	Blower Speed Tap #2
ST3	Blower Speed Tap #3
HR	Heater Relay
IT	Transformer, 40 VA
TDR	Blower Cooling Time Delay

**NOTES**

- All field wiring must be per the following:
  - National Electrical Code (NEC) and / or
  - Canadian Electrical Code (CEC) and / or
  - State, County, Local, Regional, or City Codes.
- If any of the original wire must be replaced, then replace the wire with wire that has the same temperature rating of at least 221 degF (105 degC).
- Only use copper conductors for field wiring.
- All placement components must be properly grounded.
- Provide circuit breakers sized to protect wiring from main service to the control box circuit breakers.
- Motors have internal over-temperature protection.

**CAUTION -**  
Open all disconnects before servicing this unit

WIRING DIAGRAM # 61CC0014  
FOR THE 5 kW ELECTRIC HEATER

Figure 29: 5kW Electric Heater Wiring Diagram with a Standard Digital Heating/Cooling/Heat Pump/Single Stage Programmable Thermostat, PSC blower motor.

NOTE: IF ANY OF THE ORIGINAL WIRE SUPPLIED WITH THIS UNIT MUST BE REPLACED. IT MUST BE REPLACED WITH TYPE 105°C THERMOPLASTIC OR THE EQUIVALENT.

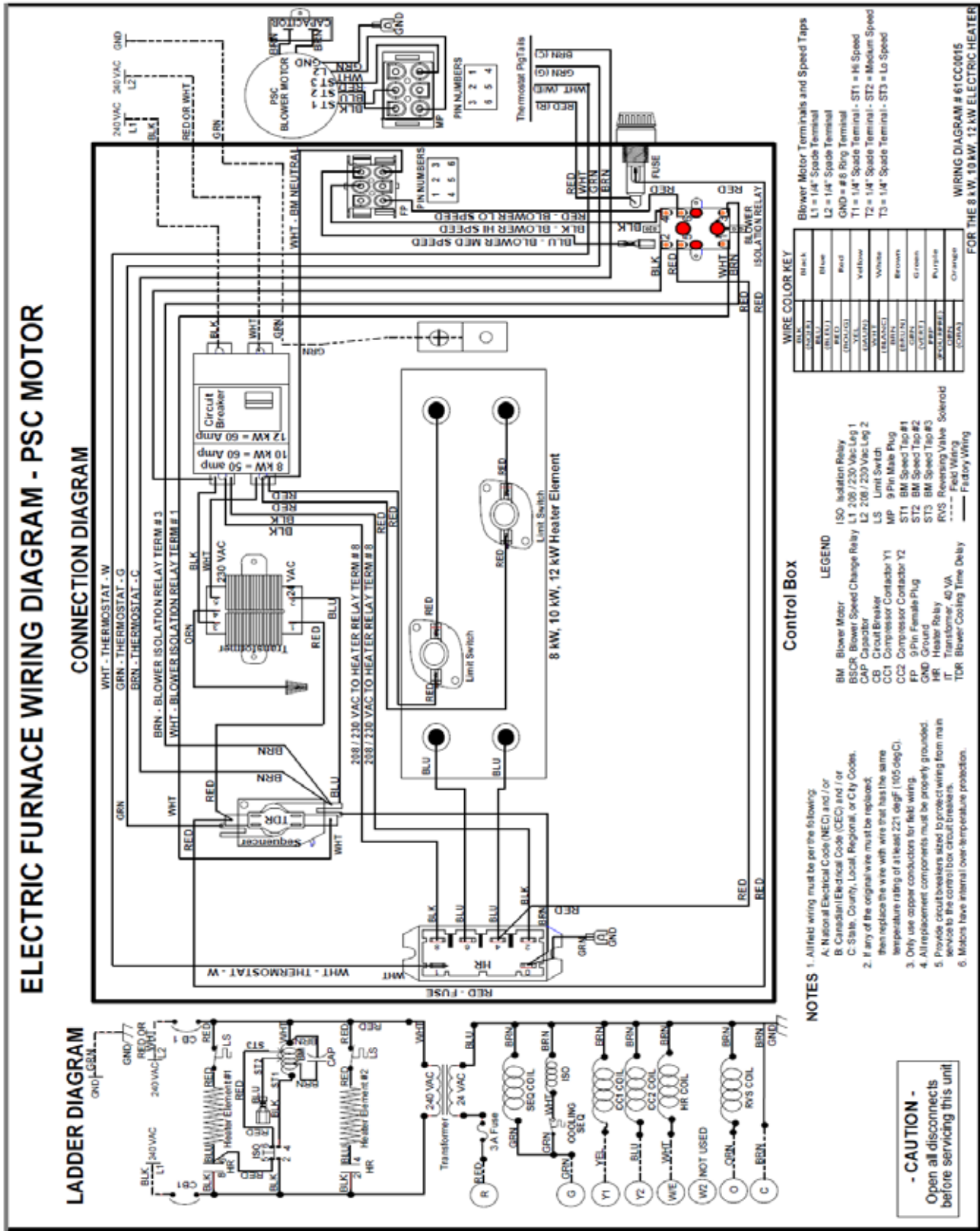

Figure 30: 8kW, 10kW, 12kW Electric Heater Wiring Diagram with a Standard Digital Heating/Cooling/Heat Pump/Single Stage Programmable Thermostat, PSC blower motor.

NOTE: IF ANY OF THE ORIGINAL WIRE SUPPLIED WITH THIS UNIT MUST BE REPLACED. IT MUST BE REPLACED WITH TYPE 105°C THERMOPLASTIC OR THE EQUIVALENT



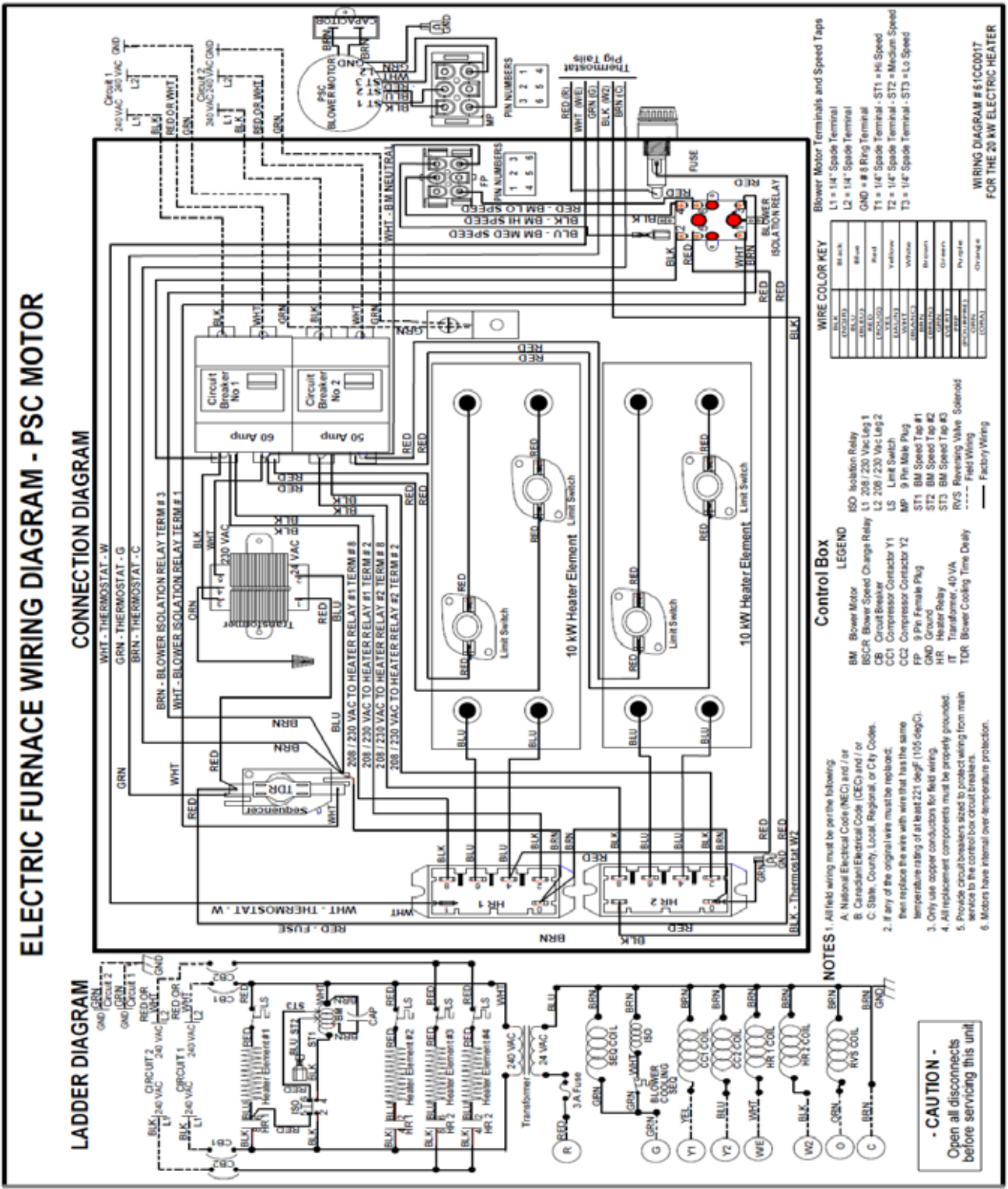

Figure 32: 20kW Electric Heater Wiring Diagram with a Standard Digital Heating/Cooling/Heat Pump/Single Stage Programmable Thermostat, PSC blower motor.

NOTE: IF ANY OF THE ORIGINAL WIRE SUPPLIED WITH THIS UNIT MUST BE REPLACED. IT MUST BE REPLACED WITH TYPE 105°C THERMOPLASTIC OR THE EQUIVALENT

Subject to change without notice  
Copyright by Mortex Products Inc. 2009.

61MH0006  
Supersedes: