

Revision B:

- Descriptions regarding the outdoor fan motor have been corrected.

Please void OBH549 REVISED EDITION-A.

OUTDOOR UNIT SERVICE MANUAL



**No. OBH549
REVISED EDITION-B**

Models

**MUZ-GE09NA
MUZ-GE12NA
MUZ-GE15NA
MUZ-GE18NA
MUZ-GE24NA
MUY-GE09NA
MUY-GE12NA
MUY-GE15NA
MUY-GE18NA
MUY-GE24NA**

Indoor unit service manual
MSZ-GE•NA MSY-GE•NA Series (OBH548)

CONTENTS

1. TECHNICAL CHANGES	2
2. PART NAMES AND FUNCTIONS.....	3
3. SPECIFICATION.....	4
4. OUTLINES AND DIMENSIONS	8
5. WIRING DIAGRAM.....	10
6. REFRIGERANT SYSTEM DIAGRAM	15
7. DATA	18
8. ACTUATOR CONTROL.....	30
9. SERVICE FUNCTIONS	31
10. TROUBLESHOOTING.....	31
11. DISASSEMBLY INSTRUCTIONS.....	49

PARTS CATALOG (OBB549)

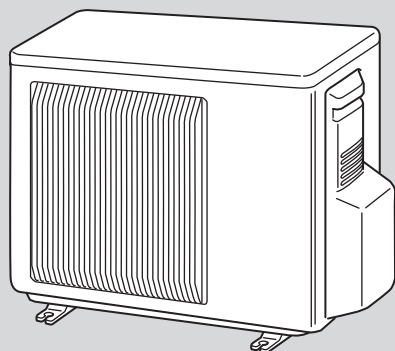

**MUZ-GE09/12/15NA
MUY-GE09/12/15NA**

NOTE:
RoHS compliant products have <G> mark on the spec name plate.

Mr. SLIM™

Revision A:

- MUZ-GE24NA and MUY-GE24NA have been added.

Revision B:

- Descriptions regarding the outdoor fan motor have been corrected.

1**TECHNICAL CHANGES**

MUZ-GE09NA
MUZ-GE12NA
MUZ-GE15NA
MUZ-GE18NA
MUZ-GE24NA
MUY-GE09NA
MUY-GE12NA
MUY-GE15NA
MUY-GE18NA
MUY-GE24NA

1. New model

2

PART NAMES AND FUNCTIONS

MUZ-GE09NA MUZ-GE12NA MUZ-GE15NA
MUY-GE09NA MUY-GE12NA MUY-GE15NA

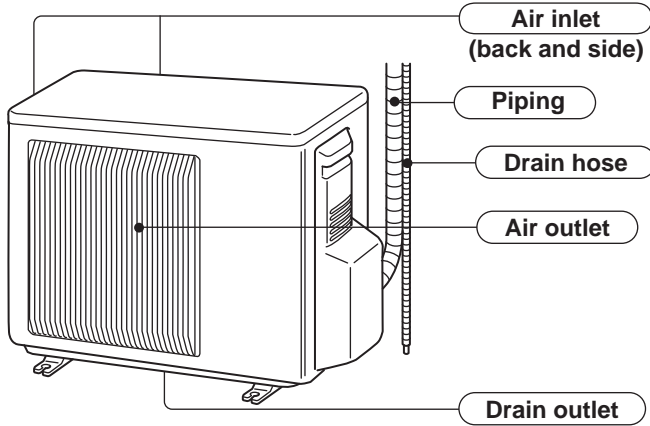

MUZ-GE18NA MUY-GE18NA

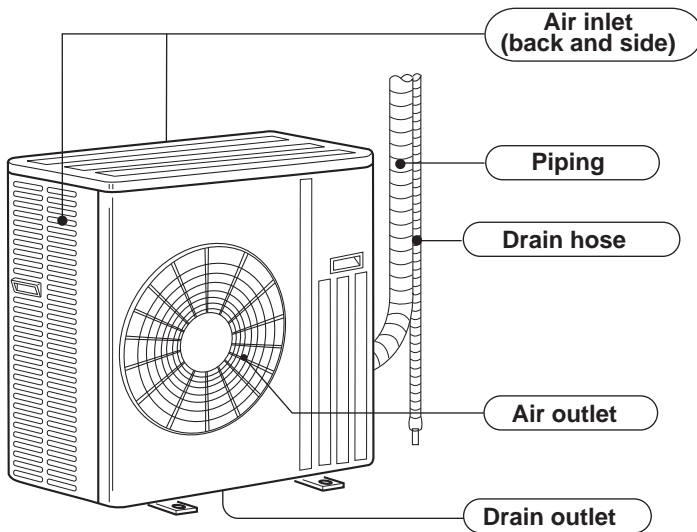

MUZ-GE24NA MUY-GE24NA

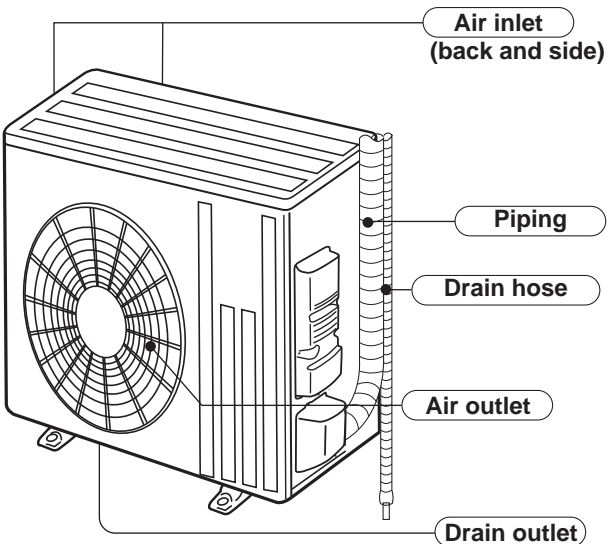

3

SPECIFICATION

Outdoor unit model			MUZ-GE09NA	MUY-GE09NA	MUZ-GE12NA	MUY-GE12NA
Capacity Rated (Minimum-Maximum)	Cooling *1	Btu/h	9,000 (3,800 ~ 12,200)	9,000 (3,800 ~ 12,200)	12,000 (3,800 ~ 13,600)	12,000 (3,800 ~ 13,600)
	Heating 47 *1	Btu/h	10,900 (4,500 ~ 14,100)	—	14,400 (5,500 ~ 18,100)	—
Capacity	Heating 17 *2	Btu/h	8,700	—	11,200	—
Power consumption Rated (Minimum-Maximum)	Cooling *1	W	660 (205~1,200)	660 (205~1,200)	960 (205~1,300)	960 (205~1,300)
	Heating 47 *1	W	760 (255~1,200)	—	1,170 (340~1,660)	—
Power consumption	Heating 17 *2	W	950	—	1,200	—
EER *1 [SEER] *3	Cooling		13.6 [21.0]	13.6 [21.0]	12.5 [20.5]	12.5 [20.5]
HSPF IV *4	Heating		10.0	—	10.0	—
COP	Heating *1		4.20	—	3.61	—
Power supply	V , phase , Hz		208/230 , 1 , 60			
Max. fuse size (time delay)	A		15			
Min. circuit ampacity	A		12	12	12	12
Fan motor	F.L.A		0.50			
Compressor	Model		KNB073FQDHC		KNB092FQAHC	
		R.L.A	6.6	4.9	6.6	4.9
		L.R.A	8.2	6.1	8.2	6.1
	Refrigeration oil (Model)	L	0.32 (NEO22)			
Refrigerant control	Linear expansion valve					
Sound level *1	Cooling	dB(A)	46	46	49	49
	Heating	dB(A)	50	—	51	—
Defrost method	Reverse cycle					
Dimensions	W	in.	31-1/2			
	D	in.	11-1/4			
	H	in.	21-5/8			
Weight	lb.		66		77	
External finish	Munsell 3Y 7.8/1.1					
Remote controller	Wireless type					
Control voltage (by built-in transformer)	VDC		12 - 24			
Refrigerant piping	Not supplied					
Refrigerant pipe size (Min. wall thickness)	Liquid	in.	1/4 (0.0315)			
	Gas	in.	3/8 (0.0315)			
Connection method	Indoor		Flared			
	Outdoor		Flared			
Between the indoor & outdoor units	Height difference	ft.	40			
	Piping length	ft.	65			
Refrigerant charge (R410A)			1 lb. 12 oz.		2 lb. 9 oz.	

NOTE: Test conditions are based on AHRI 210/240.

*1: Rating conditions (Cooling) — Indoor: 80°FDB, 67°FWB, Outdoor: 95°FDB, (75°FWB) Rated frequency
 (Heating) — Indoor: 70°FDB, 60°FWB, Outdoor: 47°FDB, 43°FWB Rated frequency
 *2: (Heating) — Indoor: 70°FDB, 60°FWB, Outdoor: 17°FDB, 15°FWB Maximum frequency

Outdoor unit model			MUZ-GE15NA	MUY-GE15NA	MUZ-GE18NA	MUY-GE18NA
Capacity Rated (Minimum-Maximum)	Cooling *1	Btu/h	14,000 (3,100 ~ 18,200)	14,000 (3,100 ~ 18,200)	17,200 (3,700 ~ 18,700)	17,200 (3,700 ~ 18,700)
	Heating 47 *1	Btu/h	18,000 (4,800 ~ 20,900)	—	21,600 (3,500 ~ 25,200)	—
Capacity	Heating 17 *2	Btu/h	15,900	—	17,200	—
Power consumption Rated (Minimum-Maximum)	Cooling *1	W	1,080 (160 ~ 2,000)	1,080 (160 ~ 2,000)	1,640 (240 ~ 2,070)	1,640 (240 ~ 2,070)
	Heating 47 *1	W	1,600 (270 ~ 2,010)	—	1,900 (230 ~ 2,680)	—
Power consumption	Heating 17 *2	W	1,950	—	2,080	—
EER *1 [SEER] *3	Cooling		13.0 [21.0]	13.0 [21.0]	10.5 [19.2]	10.5 [19.2]
HSPF IV *4	Heating		10.0	—	10.0	—
COP	Heating *1		3.30	—	3.33	—
Power supply	V , phase , Hz		208/230 , 1 , 60			
Max. fuse size (time delay)	A		15			
Min. circuit ampacity	A		12		14	
Fan motor	F.L.A		0.50		0.93	
Compressor	Model		SNB130FQBH			
		R.L.A	7.4	6.8	10.0	10.0
		L.R.A	9.3	8.5	12.5	12.5
	Refrigeration oil (Model)	L	0.45 (NEO22)			
Refrigerant control			Linear expansion valve			
Sound level *1	Cooling	dB(A)	49	49	54	54
	Heating	dB(A)	51	—	56	—
Defrost method			Reverse cycle			
Dimensions	W	in.	31-1/2		33-1/16	
	D	in.	11-1/4		13	
	H	in.	21-5/8		33-7/16	
Weight	lb.		80		119	
External finish			Munsell 3Y 7.8/1.1			
Remote controller			Wireless type			
Control voltage (by built-in transformer)	VDC		12 - 24			
Refrigerant piping			Not supplied			
Refrigerant pipe size (Min. wall thickness)	Liquid	in.	1/4 (0.0315)			
	Gas	in.	1/2 (0.0315)			
Connection method	Indoor		Flared			
	Outdoor		Flared			
Between the indoor & outdoor units	Height difference	ft.	40		50	
	Piping length	ft.	65		100	
Refrigerant charge (R410A)			2 lb. 9 oz.		3 lb. 7 oz.	

NOTE: Test conditions are based on AHRI 210/240.

*1: Rating conditions (Cooling) — Indoor: 80°FDB, 67°FWB, Outdoor: 95°FDB, (75°FWB) Rated frequency
(Heating) — Indoor: 70°FDB, 60°FWB, Outdoor: 47°FDB, 43°FWB Rated frequency
*2: (Heating) — Indoor: 70°FDB, 60°FWB, Outdoor: 17°FDB, 15°FWB Maximum frequency

Outdoor unit model			MUZ-GE24NA	MUY-GE24NA
Capacity Rated (Minimum~Maximum)	Cooling *1	Btu/h	22,500 (8,200 ~ 31,400)	22,500 (8,200 ~ 31,400)
	Heating 47 *1	Btu/h	27,600 (7,500 ~ 36,900)	—
Capacity	Heating 17 *2	Btu/h	24,600	—
Power consumption Rated (Minimum~Maximum)	Cooling *1	W	1,800 (570 ~ 3,580)	1,800 (570 ~ 3,580)
	Heating 47 *1	W	2,340 (520 ~ 3,650)	—
Power consumption	Heating 17 *2	W	3,290	—
EER *1 [SEER] *3	Cooling		12.5 [19.0]	12.5 [19.0]
HSPF IV *4	Heating		10.0	—
COP	Heating *1		3.46	—
Power supply	V , phase , Hz		208/230 , 1 , 60	
Max. fuse size (time delay)		A	20	
Min. circuit ampacity		A	17.1	
Fan motor		F.L.A	0.93	
Compressor	Model		SNB172FQKMT	
		R.L.A	12.9	
		L.R.A	16.1	
	Refrigeration oil (Model)	L	0.40 (FV50S)	
Refrigerant control			Linear expansion valve	
Sound level *1	Cooling	dB(A)	55	55
	Heating	dB(A)	55	—
Defrost method			Reverse cycle	
Dimensions	W	in.	33-1/16	
	D	in.	13	
	H	in.	34-5/8	
Weight		lb.	119	
External finish			Munsell 3Y 7.8/1.1	
Remote controller			Wireless type	
Control voltage (by built-in transformer)		VDC	12-24	
Refrigerant piping			Not supplied	
Refrigerant pipe size (Min. wall thickness)	Liquid	in.	3/8 (0.0315)	
	Gas	in.	5/8 (0.0315)	
Connection method	Indoor		Flared	
	Outdoor		Flared	
Between the indoor & outdoor units	Height difference	ft.	50	
	Piping length	ft.	100	
Refrigerant charge (R410A)			4 lb. 3 oz.	

NOTE: Test conditions are based on AHRI 210/240.

*1: Rating conditions (Cooling) — Indoor: 80°FDB, 67°FWB, Outdoor: 95°FDB, (75°FWB) Rated frequency
(Heating) — Indoor: 70°FDB, 60°FWB, Outdoor: 47°FDB, 43°FWB Rated frequency
*2: (Heating) — Indoor: 70°FDB, 60°FWB, Outdoor: 17°FDB, 15°FWB Maximum frequency

Test condition

※3,※4

ARI	Mode	Test	Indoor air condition (°F)		Outdoor air condition (°F)	
			Dry bulb	Wet bulb	Dry bulb	Wet bulb
	SEER (Cooling)	"A-2" Cooling Steady State at rated compressor Speed	80	67	95	(75)
		"B-2" Cooling Steady State at rated compressor Speed	80	67	82	(65)
		"B-1" Cooling Steady State at minimum compressor Speed	80	67	82	(65)
		"F-1" Cooling Steady State at minimum compressor Speed	80	67	67	(53.5)
		"E-V" Cooling Steady State at Intermediate compressor Speed ※5	80	67	87	(69)
	HSPF (Heating) (MUZ)	"H1-2" Heating Steady State at rated compressor Speed	70	60	47	43
		"H3-2" Heating at rated compressor Speed	70	60	17	15
		"H0-1" Heating Steady State at minimum compressor Speed	70	60	62	56.5
		"H1-1" Heating Steady State at minimum compressor Speed	70	60	47	43
		"H2-V" Heating at Intermediate compressor Speed ※5	70	60	35	33

※5: At Intermediate compressor Speed
= ("Cooling rated compressor speed" - "minimum compressor speed") / 3 + "minimum compressor speed".

3-1. OPERATING RANGE

(1) POWER SUPPLY

	Rated voltage	Guaranteed voltage (V)
Outdoor unit	208/230 V 1 phase 60 Hz	

(2) OPERATION

Mode	Condition	Intake air temperature (°F)			
		Indoor		Outdoor	
		DB	WB	DB	WB
Cooling	Standard temperature	80	67	95	—
	Maximum temperature	90	73	115	—
	Minimum temperature	67	57	14	—
	Maximum humidity	78 %		—	
Heating (MUZ)	Standard temperature	70	60	47	43
	Maximum temperature	80	67	75	65
	Minimum temperature	70	60	-4	-5

4

OUTLINES AND DIMENSIONS

MUZ-GE09NA MUZ-GE12NA MUZ-GE15NA
 MUY-GE09NA MUY-GE12NA MUY-GE15NA

Unit: inch

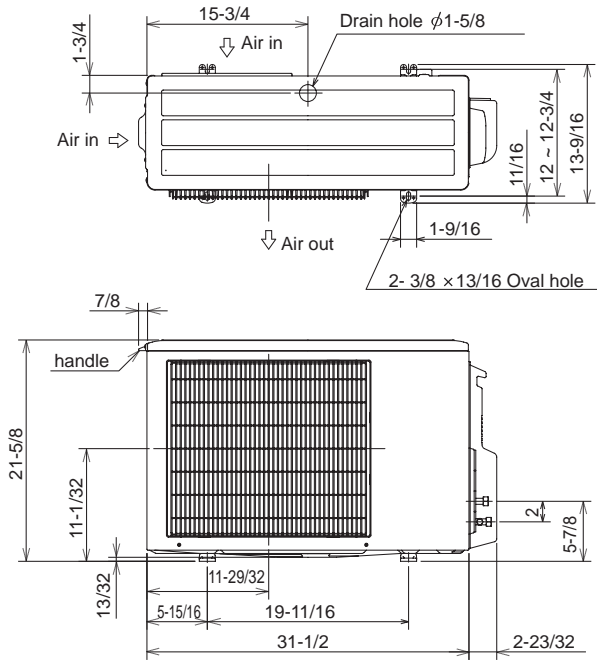

REQUIRED SPACE

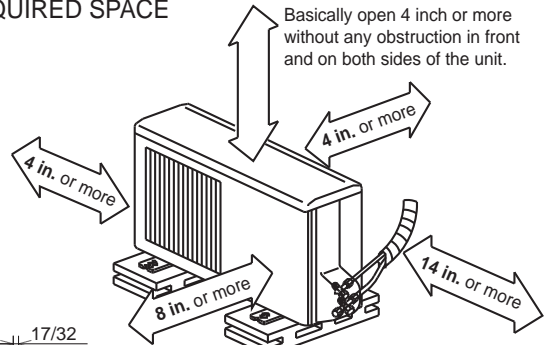

Open two sides of left, right, or rear side.

Liquid pipe : 1/4 (flared)
 Gas pipe : 3/8 (flared) (GE09/12)
 1/2 (flared) (GE15)

MUZ-GE18NA MUY-GE18NA

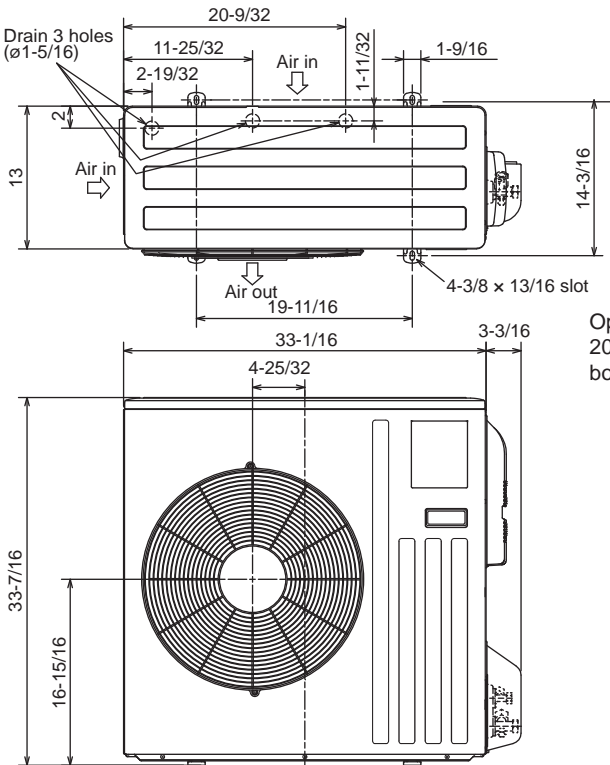

REQUIRED SPACE

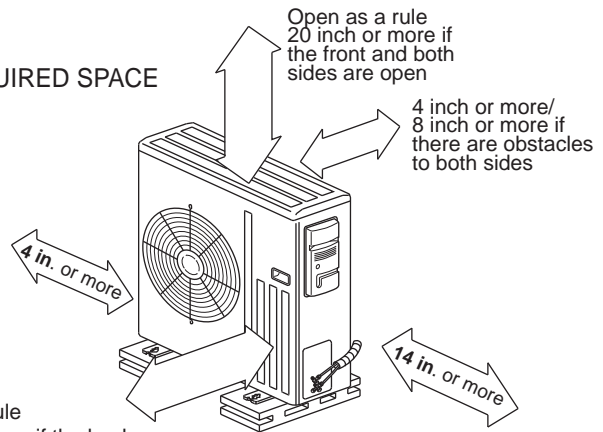

Open as a rule 20 inch or more if the back, both sides and top are open

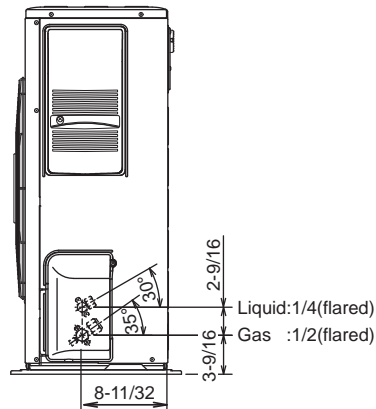

MUZ-GE24NA
MUY-GE24NA

Unit: inch

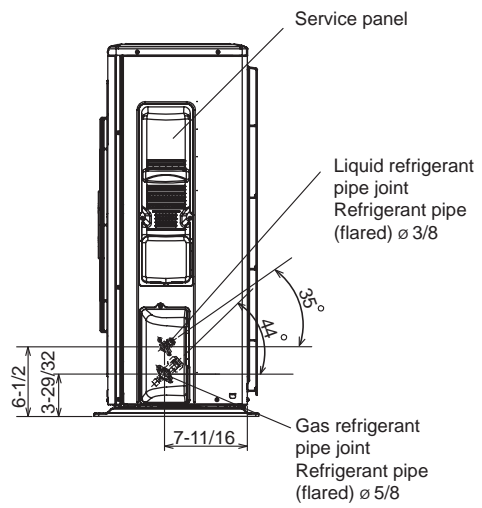
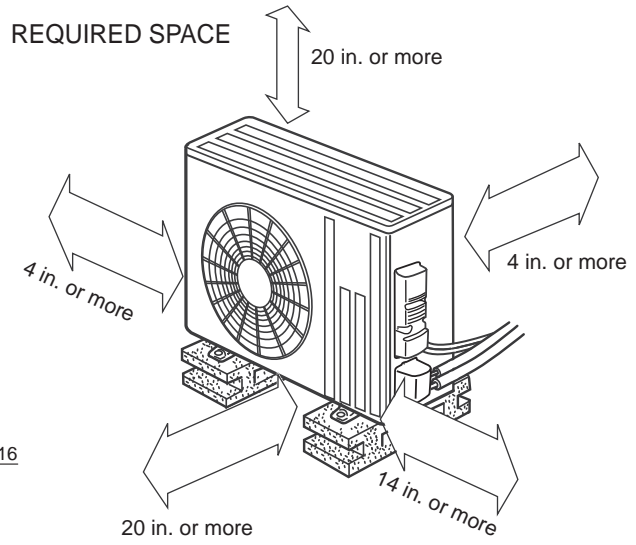
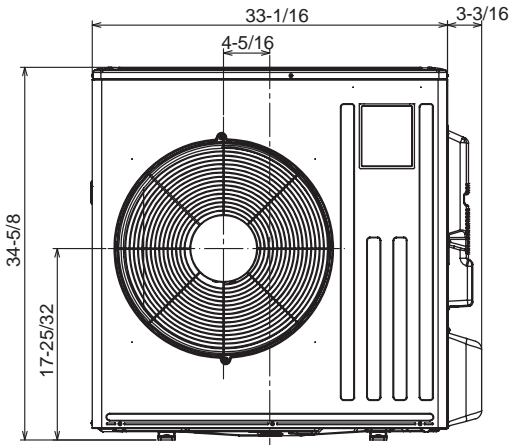
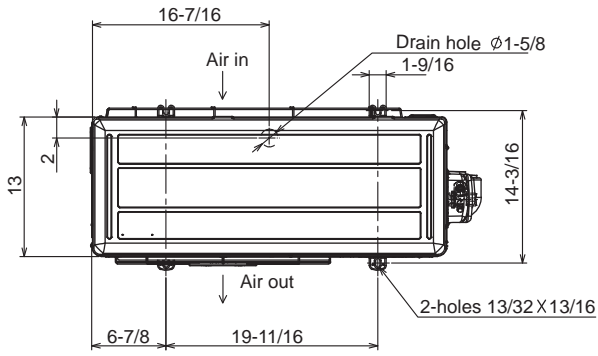

5

WIRING DIAGRAM

MUZ-GE09NA MUZ-GE12NA

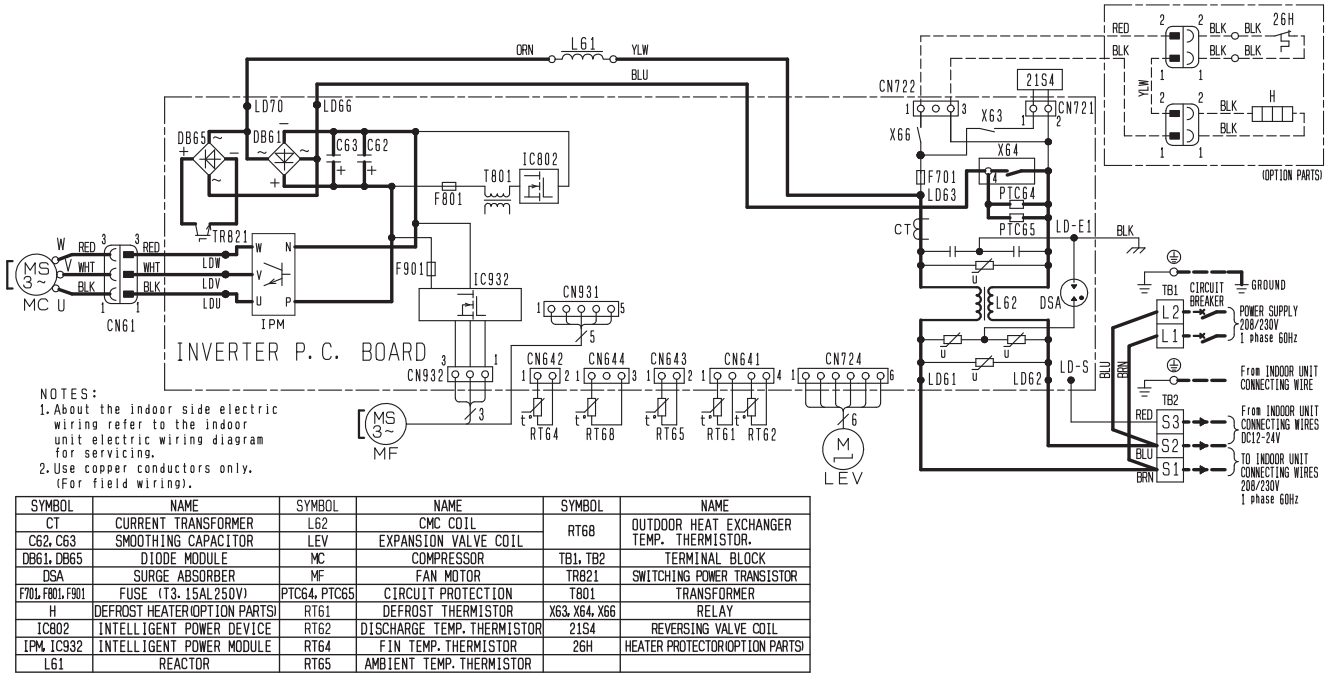

MUY-GE09NA MUY-GE12NA

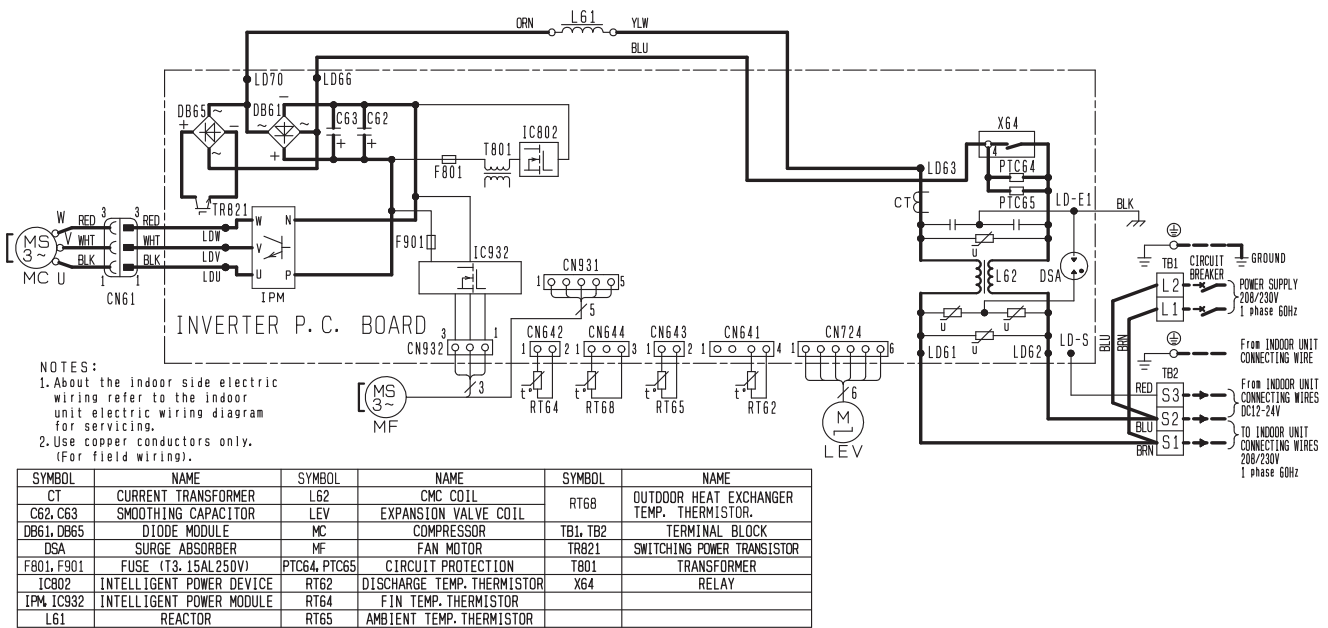

MUZ-GE15NA

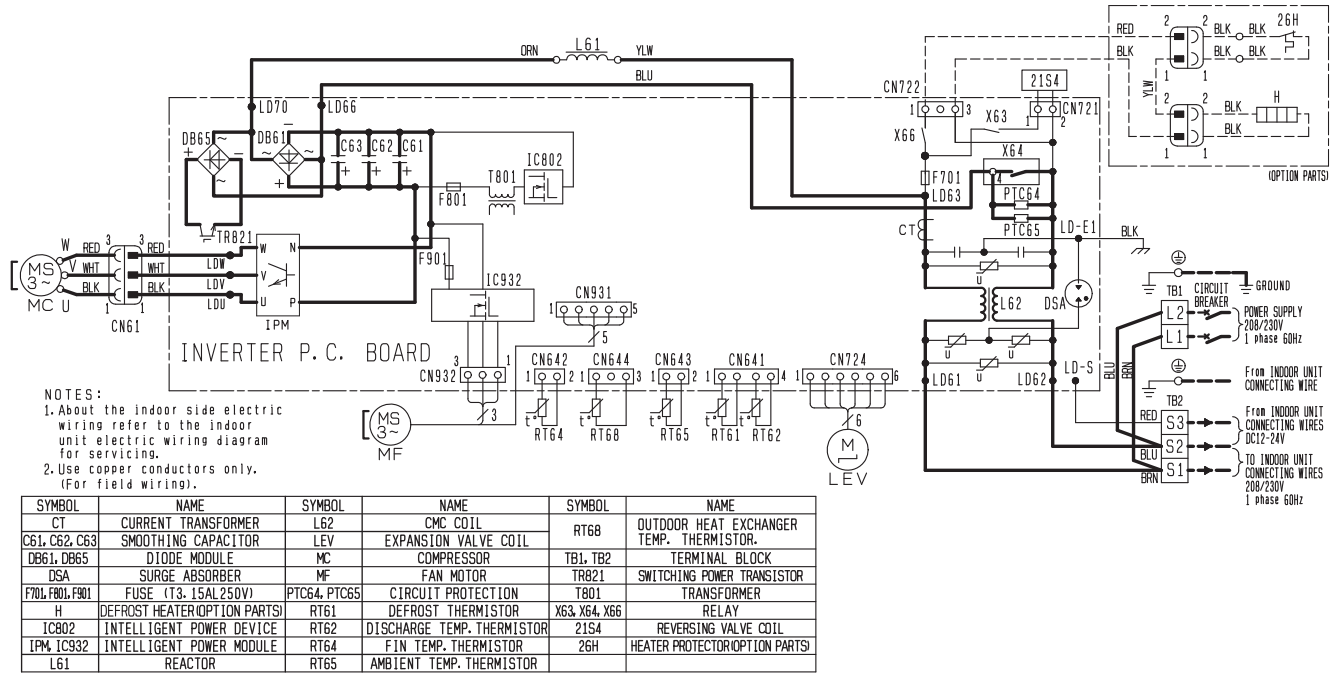

MUY-GE15NA

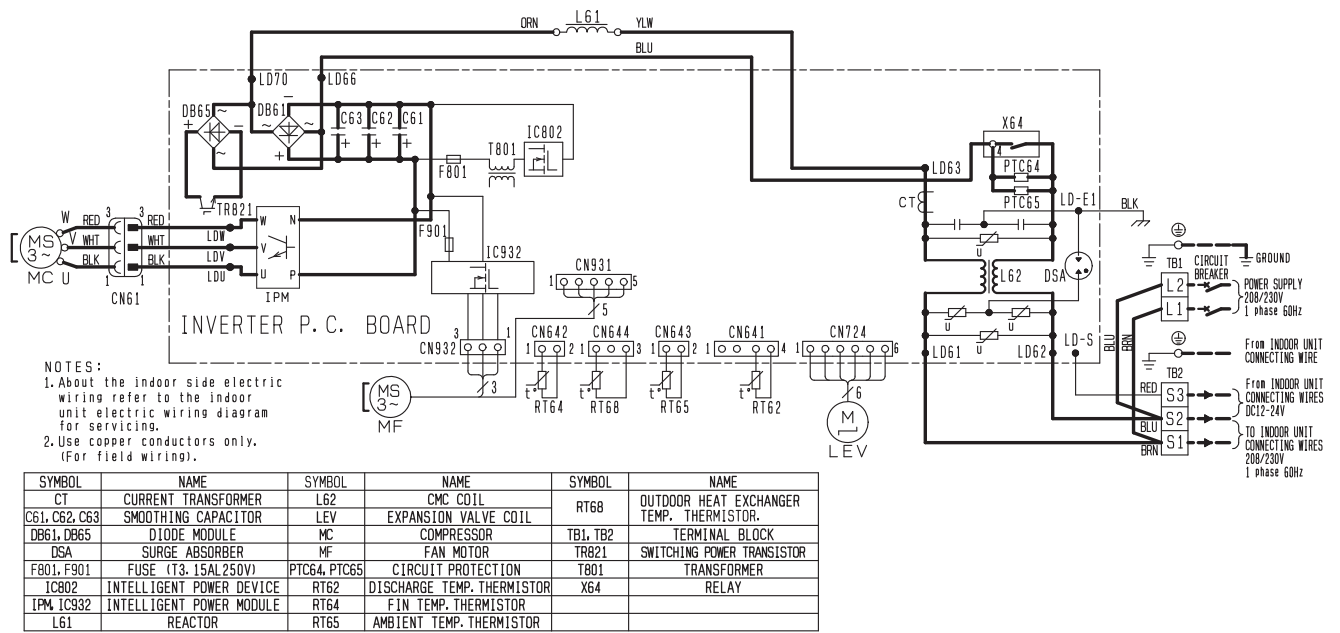

MUZ-GE18NA

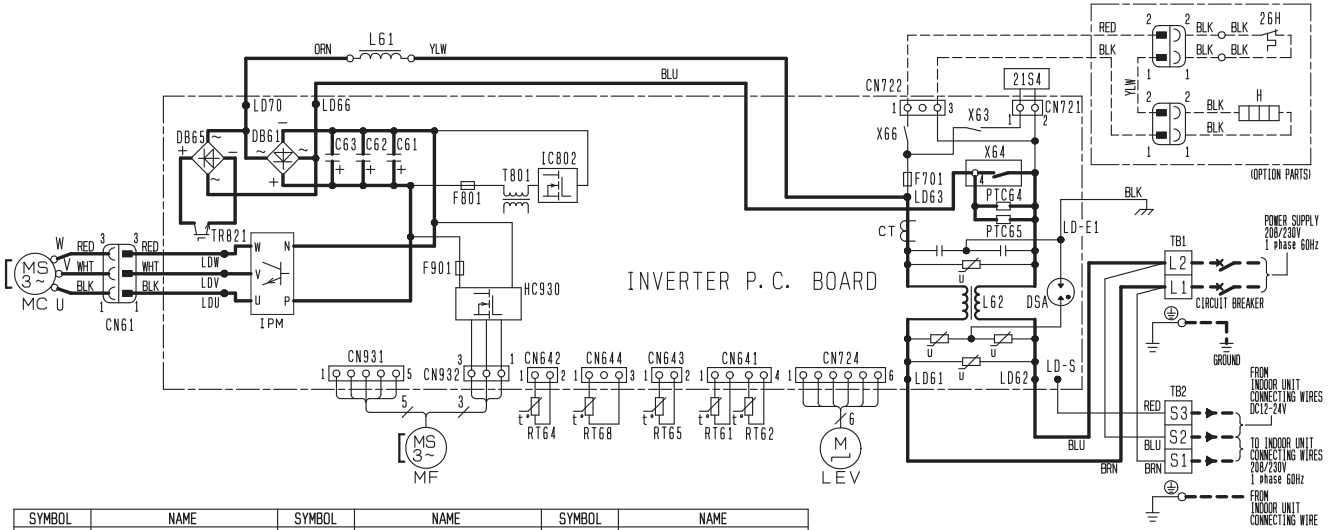

SYMBOL	NAME	SYMBOL	NAME	SYMBOL	NAME
CT	CURRENT TRANSFORMER	L62	CMC COIL	RT68	OUTDOOR HEAT EXCHANGER TEMP. THERMISTOR.
C61, C62, C63	SMOOTHING CAPACITOR	LEV	EXPANSTON VALVE COIL	TB1, TB2	TERMINAL BLOCK
DB61, DB65	DIODE MODULE	MC	COMPRESSOR	TR821	SWITCHING POWER TRANSISTOR
DSA	SURGE ABSORBER	MF	FAN MOTOR	T801	TRANSFORMER
F701, F901, F901	FUSE (T3, 15AL 250V)	PTC64, PTC65	CIRCUIT PROTECTION	T801	TRANSFORMER
H	DEFROST HEATER (OPTION PARTS)	RT61	DEFROST THERMISTOR	X63, X64, X66	RELAY
HC930, IPM	INTELLIGENT POWER MODULE	RT62	DISCHARGE TEMP. THERMISTOR	21S4	REVERSING VALVE COIL
IC802	INTELLIGENT POWER DEVICE	RT64	FIN TEMP. THERMISTOR	26H	HEATER PROTECTOR (OPTION PARTS)
L61	REACTOR	RT65	AMBIENT TEMP. THERMISTOR		

MUY-GE18NA

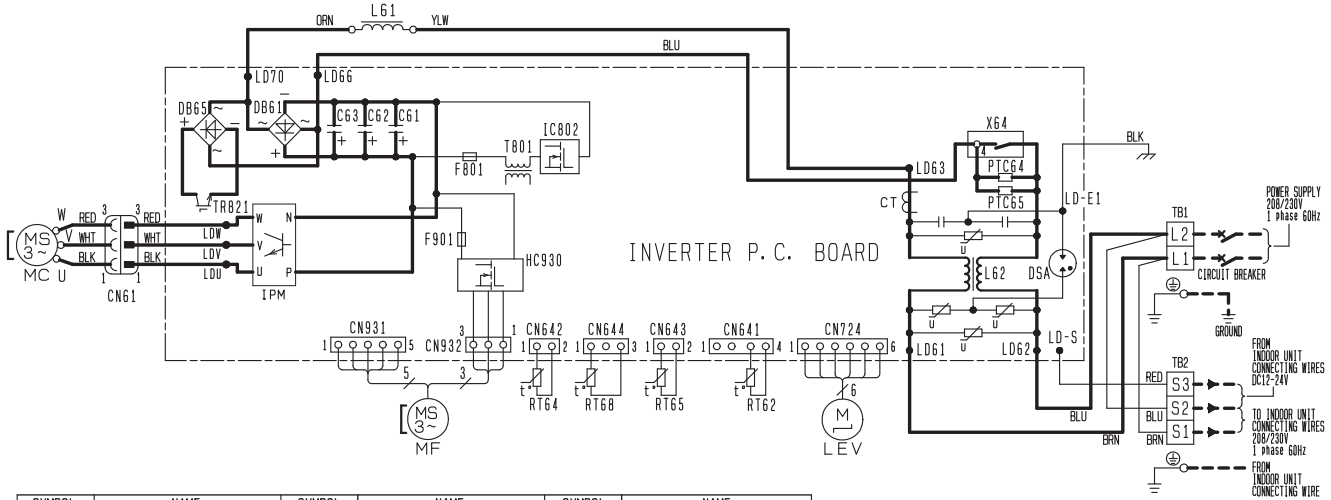

SYMBOL	NAME	SYMBOL	NAME	SYMBOL	NAME
CT	CURRENT TRANSFORMER	L62	CMC COIL	RT68	OUTDOOR HEAT EXCHANGER TEMP. THERMISTOR.
C61, C62, C63	SMOOTHING CAPACITOR	LEV	EXPANSTON VALVE COIL	TB1, TB2	TERMINAL BLOCK
DB61, DB65	DIODE MODULE	MC	COMPRESSOR	TR821	SWITCHING POWER TRANSISTOR
DSA	SURGE ABSORBER	MF	FAN MOTOR	T801	TRANSFORMER
F701, F901	FUSE (T3, 15AL 250V)	PTC64, PTC65	CIRCUIT PROTECTION	X64	RELAY
HC930, IPM	INTELLIGENT POWER MODULE	RT62	DISCHARGE TEMP. THERMISTOR		
IC802	INTELLIGENT POWER DEVICE	RT64	FIN TEMP. THERMISTOR		
L61	REACTOR	RT65	AMBIENT TEMP. THERMISTOR		

MUZ-GE24NA

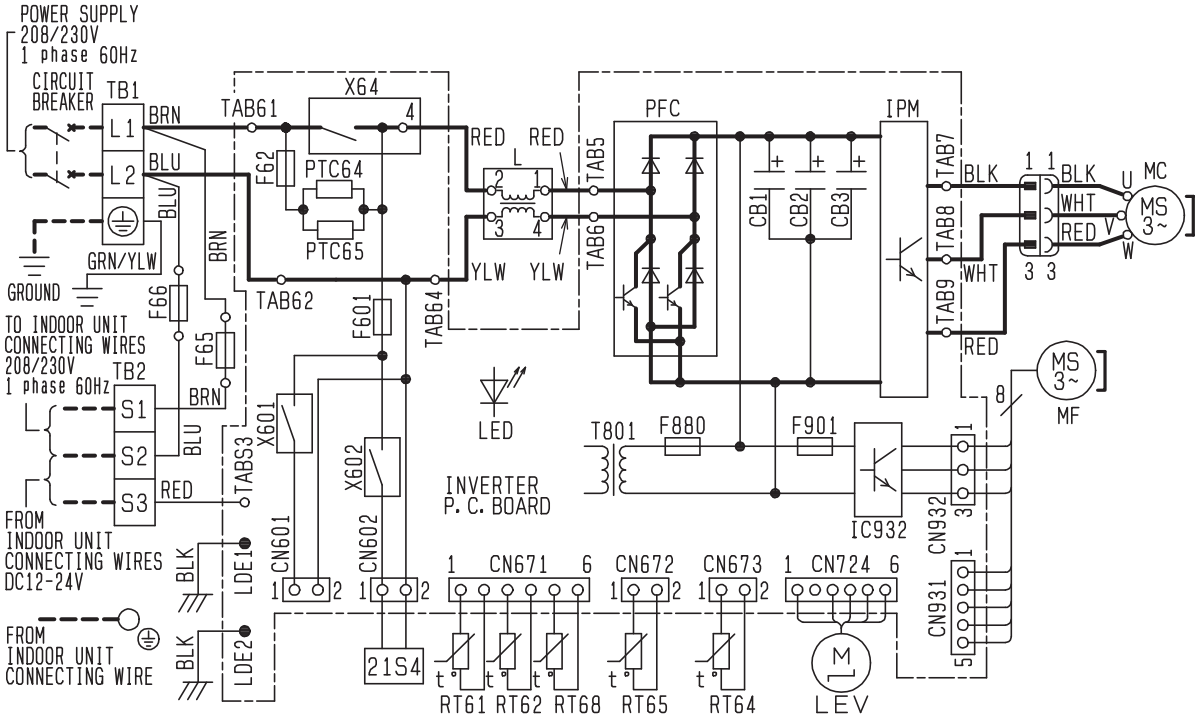

SYMBOL	NAME	SYMBOL	NAME
CB1 ~ 3	SMOOTHING CAPACITOR	PTC64	CIRCUIT PROTECTION
F601	FUSE (T3, 15A/250V)	PTC65	CIRCUIT PROTECTION
F62	FUSE (T2AL/250V)	RT61	DEFROST THERMISTOR
F65, F66	FUSE (T6, 3A/250V)	RT62	DISCHARGE TEMP. THERMISTOR
F880	FUSE (T3, 15A/250V)	RT64	FIN TEMP. THERMISTOR
F901	FUSE (T3, 15A/250V)	RT65	AMBIENT TEMP. THERMISTOR
IC932	INTELLIGENT POWER MODULE	RT68	OUTDOOR HEAT EXCHANGER TEMP. THERMISTOR
IPM	INTELLIGENT POWER MODULE	TB1, TB2	TERMINAL BLOCK
L	REACTOR	T801	TRANSFORMER
LEV	EXPANSION VALVE COIL	X601, X602	RELAY
MC	COMPRESSOR	X64	RELAY
MF	FAN MOTOR	21S4	REVERSING VALVE SOLENOID COIL
PFC	POWER FACTOR CONTROLLER		

NOTES 1. About the indoor side electric wiring, refer to the indoor unit electric wiring diagram for servicing.
 2. Use copper conductors only (for field wiring).
 3. Symbols indicate. : Terminal block

MUY-GE24NA

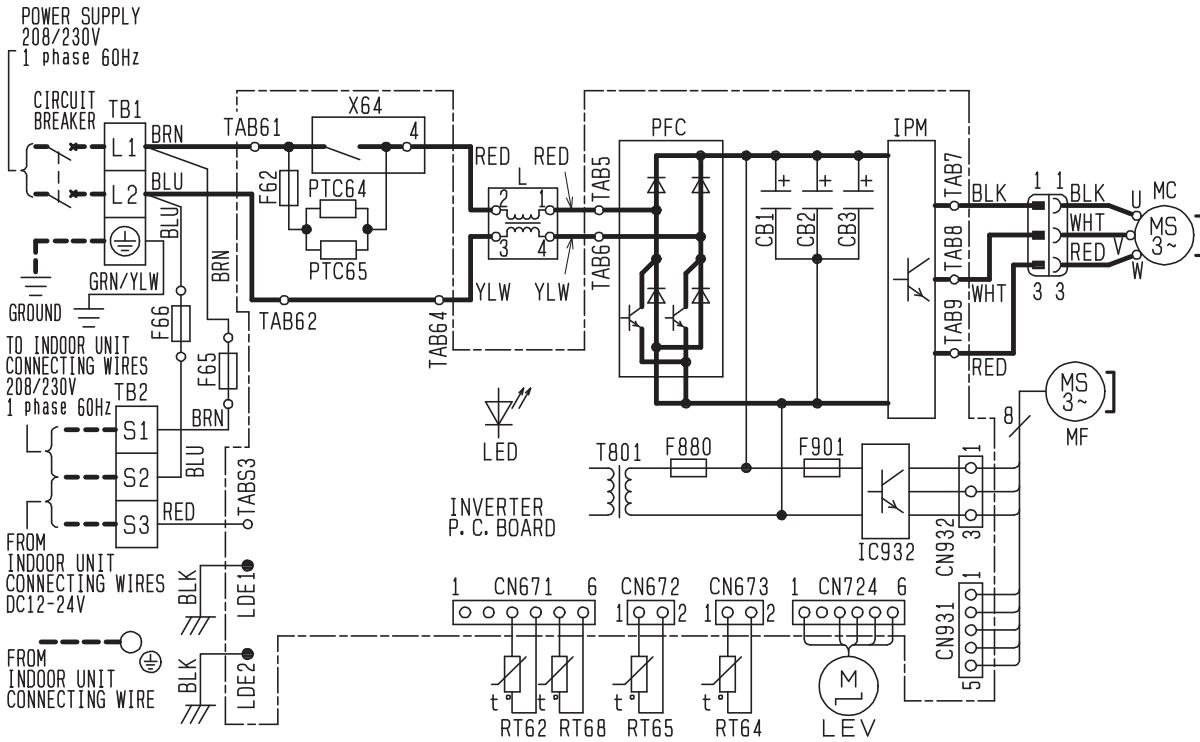

SYMBOL	NAME	SYMBOL	NAME
CB1~3	SMOOTHING CAPACITOR	PFC	POWER FACTOR CONTROLLER
F62	FUSE (T2AL250V)	PTC64	CIRCUIT PROTECTION
F65, F66	FUSE (T6. 3AL250V)	PTC65	CIRCUIT PROTECTION
F880	FUSE (T3. 15AL250V)	RT62	DISCHARGE TEMP. THERMISTOR
F901	FUSE (T3. 15AL250V)	RT64	FIN TEMP. THERMISTOR
IC932	INTELLIGENT POWER MODULE	RT65	AMBIENT TEMP. THERMISTOR
IPM	INTELLIGENT POWER MODULE	RT68	OUTDOOR HEAT EXCHANGER TEMP. THERMISTOR
L	REACTOR	TB1, TB2	TERMINAL BLOCK
LEV	EXPANSION VALVE COIL	T801	TRANSFORMER
MC	COMPRESSOR	X64	RELAY

NOTES
 1. About the indoor side electric wiring, refer to the indoor unit electric wiring diagram for servicing.
 2. Use copper conductors only (for field wiring).
 3. Symbols indicate. : Terminal block

6

REFRIGERANT SYSTEM DIAGRAM

MUZ-GE09NA MUY-GE09NA

Unit: inch

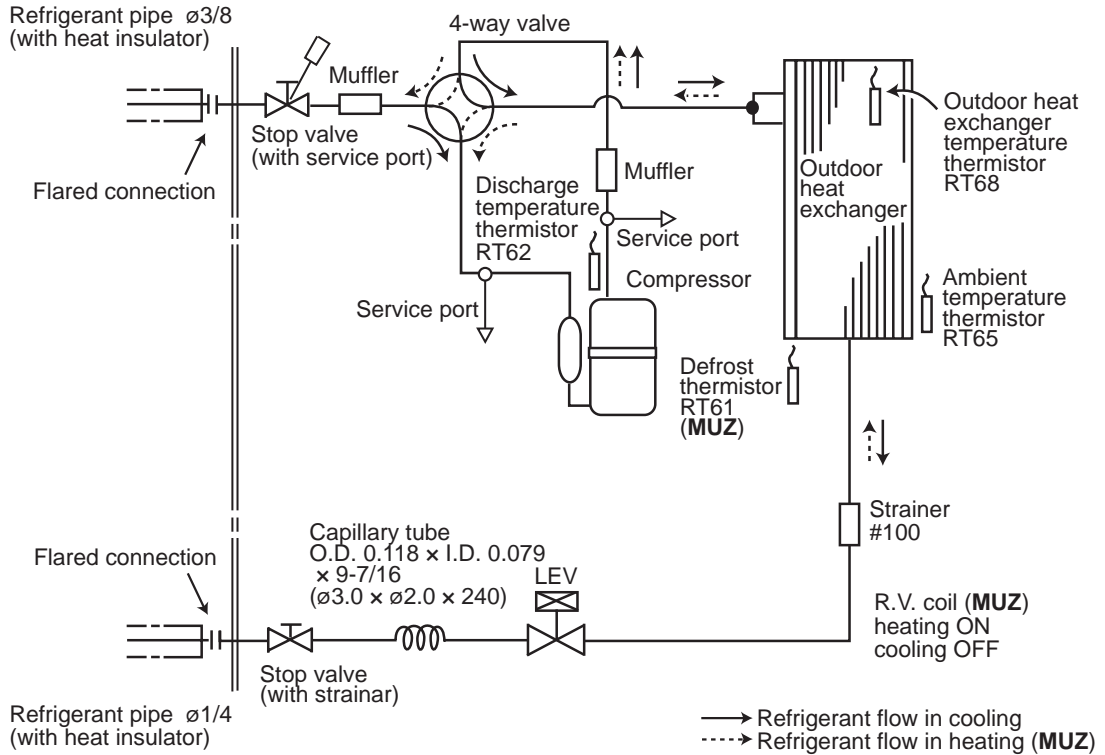

MUZ-GE12NA MUZ-GE15NA MUY-GE12NA MUY-GE15NA

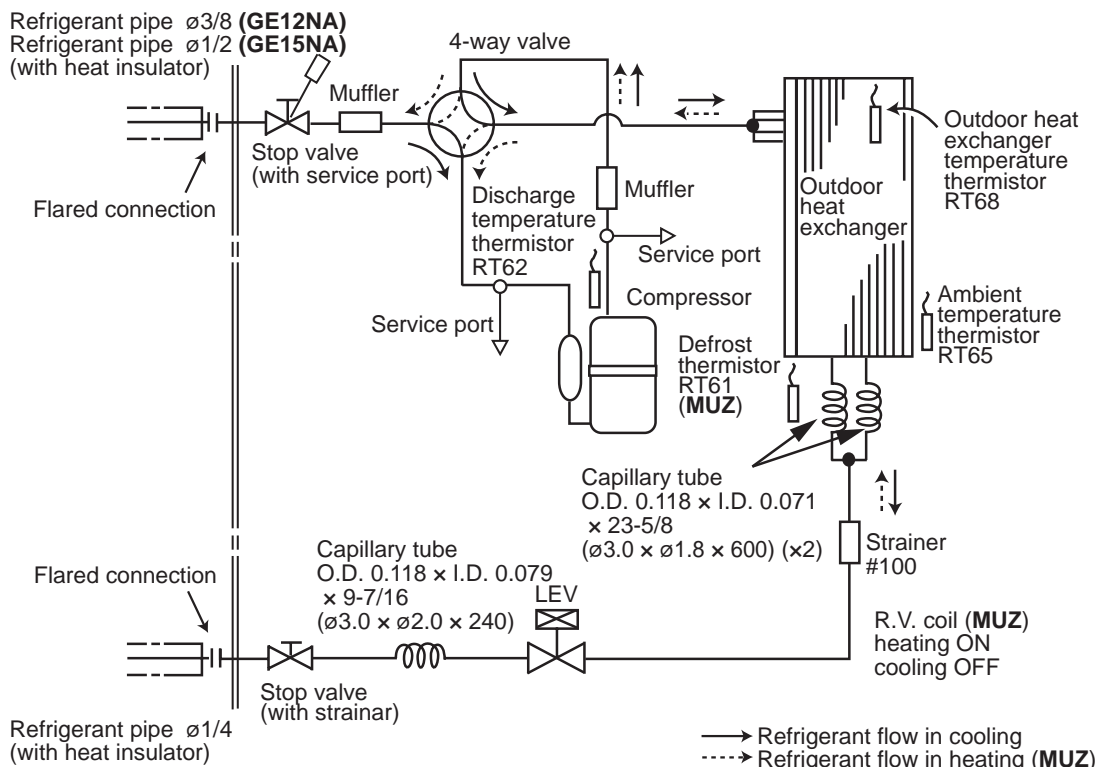

MUZ-GE18NA MUY-GE18NA

Unit: inch

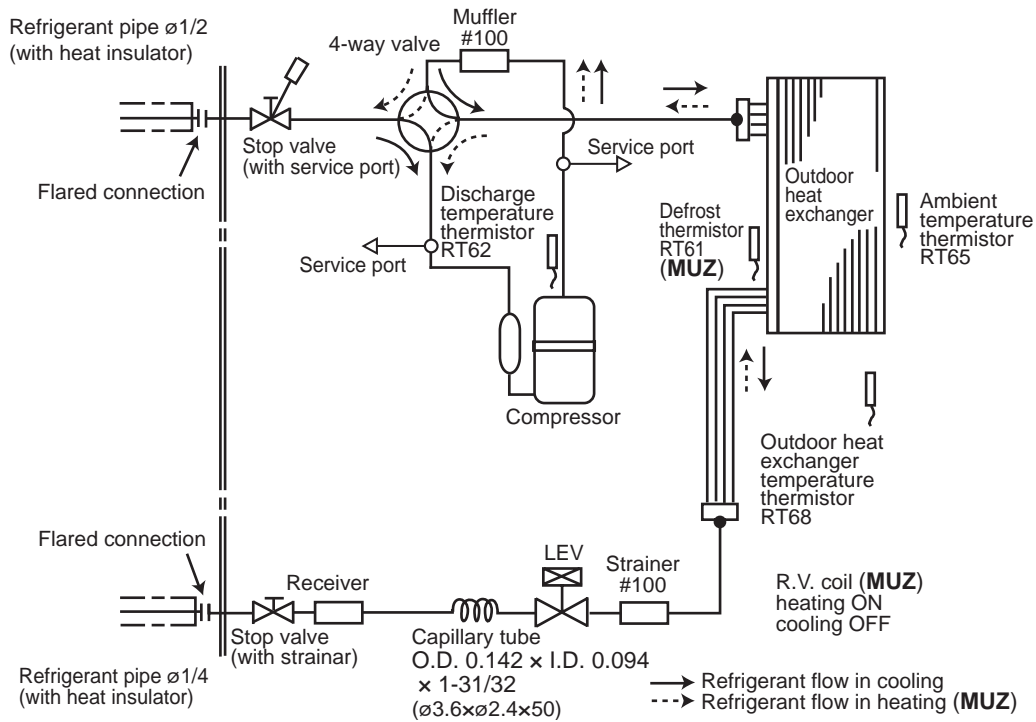

MUZ-GE24NA MUY-GE24NA

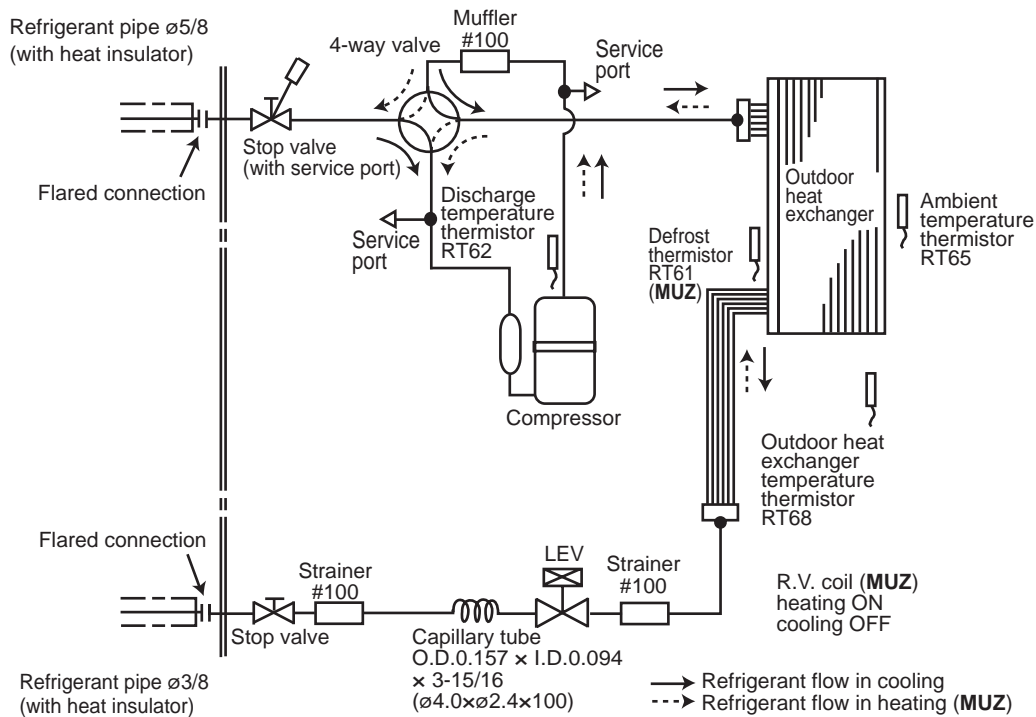

MAX. REFRIGERANT PIPING LENGTH and MAX. HEIGHT DIFFERENCE

Model	Refrigerant piping: ft.		Piping size O.D: in.	
	Max. Length A	Max. Height difference B	Gas	Liquid
MUZ-GE09/12/15NA MUY-GE09/12/15NA	65	40	3/8 (GE09/12) 1/2 (GE15)	1/4
MUZ-GE18NA MUY-GE18NA	100	50	1/2	
MUZ-GE24NA MUY-GE24NA	100	50	5/8	3/8

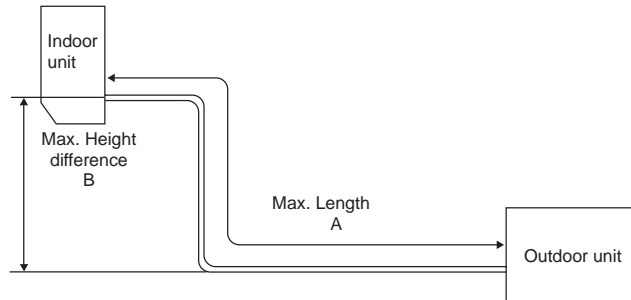

ADDITIONAL REFRIGERANT CHARGE (R410A: oz.)

NOTE: Refrigerant piping exceeding 25 ft. requires additional refrigerant charge according to the calculation.

Model	Outdoor unit precharged	Refrigerant piping length (one way): ft.					
		25	30	40	50	60	65
MUZ-GE09NA MUY-GE09NA	1 lb. 12 oz.	0	1.62	4.86	8.10	11.34	12.96
MUZ-GE12NA MUY-GE12NA	2 lb. 9 oz.						
MUZ-GE15NA MUY-GE15NA							

Calculation: X oz. = 1.62/5 oz. / ft. × (Refrigerant piping length (ft.) - 25)

Model	Outdoor unit precharged	Refrigerant piping length (one way): ft.								
		25	30	40	50	60	70	80	90	100
MUZ-GE18NA MUY-GE18NA	3 lb. 7 oz.	0	1.08	3.24	5.40	7.56	9.72	11.88	14.04	16.20

Calculation: X oz. = 1.08/5 oz. / ft. × (Refrigerant piping length (ft.) - 25)

NOTE: Refrigerant piping exceeding 33 ft. requires additional refrigerant charge according to the calculation.

Model	Outdoor unit precharged	Refrigerant piping length (one way): ft.							
		33	40	50	60	70	80	90	100
MUZ-GE24NA MUY-GE24NA	4 lb. 3 oz.	0	4.14	10.06	15.98	21.90	27.82	33.74	39.66

Calculation: X oz. = 2.96/5 oz. / ft. × (Refrigerant piping length (ft.) - 33)

7

DATA

7-1. PERFORMANCE DATA

1) COOLING CAPACITY

MUZ-GE09NA MUZ-GE12NA MUZ-GE15NA MUZ-GE18NA MUZ-GE24NA
 MUY-GE09NA MUY-GE12VA MUY-GE15VA MUY-GE18VA MUY-GE24VA

Model	Indoor air		Outdoor intake air DB temperature (°F)													
	IWB (°F)	75			85			95			105			115		
		TC	SHC	TPC	TC	SHC	TPC	TC	SHC	TPC	TC	SHC	TPC	TC	SHC	TPC
MUZ-GE09NA MUY-GE09NA	71	11.0	7.6	0.59	10.3	7.1	0.64	9.7	6.6	0.69	9.0	6.2	0.73	8.3	5.7	0.76
	67	10.4	8.6	0.55	9.7	8.0	0.61	9.0	7.4	0.66	8.4	6.9	0.70	7.7	6.3	0.73
	63	9.8	9.4	0.53	9.1	8.7	0.58	8.5	8.1	0.63	7.7	7.3	0.67	7.0	6.7	0.70
MUZ-GE12NA MUY-GE12NA	71	14.7	8.9	0.85	13.7	8.3	0.94	12.9	7.8	1.01	12.0	7.3	1.06	11.0	6.7	1.10
	67	13.9	10.3	0.81	13.0	9.6	0.89	12.0	8.9	0.96	11.2	8.3	1.02	10.3	7.6	1.07
	63	13.1	11.4	0.77	12.1	10.6	0.85	11.3	9.9	0.92	10.3	9.0	0.98	9.4	8.2	1.02
MUZ-GE15NA MUY-GE15NA	71	17.2	11.4	0.96	16.0	10.7	1.05	15.1	10.0	1.13	14.0	9.3	1.19	12.9	8.6	1.24
	67	16.2	13.0	0.91	15.1	12.1	1.00	14.0	11.2	1.08	13.0	10.4	1.14	12.0	9.6	1.20
	63	15.3	14.2	0.86	14.1	13.2	0.96	13.2	12.3	1.03	12.0	11.2	1.10	10.9	10.2	1.14
MUZ-GE18NA MUY-GE18NA	71	21.1	12.2	1.46	19.7	11.4	1.60	18.5	10.7	1.72	17.2	9.9	1.81	15.8	9.1	1.89
	67	20.0	14.2	1.38	18.6	13.2	1.52	17.2	12.2	1.64	16.0	11.4	1.74	14.7	10.4	1.82
	63	18.7	15.8	1.31	17.4	14.7	1.45	16.2	13.6	1.57	14.7	12.4	1.67	13.4	11.3	1.74
MUZ-GE24NA MUY-GE24NA	71	27.6	17.0	1.60	25.8	15.9	1.76	24.2	14.9	1.89	22.5	13.9	1.99	20.7	12.8	2.07
	67	26.1	19.6	1.51	24.3	18.2	1.67	22.5	16.9	1.80	20.9	15.7	1.91	19.2	14.4	2.00
	63	24.5	21.7	1.44	22.7	20.1	1.59	21.2	18.7	1.72	19.2	17.0	1.84	17.6	15.5	1.91

NOTE: 1. IWB: Intake air wet-bulb temperature
 TC: Total Capacity ($\times 10^3$ Btu/h)
 SHC: Sensible Heat Capacity ($\times 10^3$ Btu/h)
 TPC: Total Power Consumption (kW)
 2. SHC is based on 80°F of indoor Intake air DB temperature.

2) COOLING CAPACITY CORRECTIONS

	Refrigerant piping length (one way: ft.)			
	25 (std.)	40	65	100
MUZ-GE09NA MUY-GE09NA MUZ-GE12NA MUY-GE12NA MUZ-GE15NA MUY-GE15NA MUZ-GE18NA MUY-GE18NA	1.0	0.954	0.878	—
MUZ-GE24NA MUY-GE24NA	1.0	0.954	0.878	0.771

3) HEATING CAPACITY (MUZ)

Model	Indoor air IDB (°F)	Outdoor intake air WB temperature (°F)													
		5		15		25		35		43		45		55	
		TC	TPC	TC	TPC	TC	TPC	TC	TPC	TC	TPC	TC	TPC	TC	TPC
MUZ-GE09NA	75	4.8	0.45	6.3	0.57	7.9	0.67	9.4	0.74	10.6	0.78	11.0	0.79	12.4	0.82
	70	5.2	0.43	6.7	0.55	8.2	0.65	9.6	0.72	10.9	0.76	11.2	0.78	12.7	0.81
	65	5.5	0.41	6.9	0.52	8.6	0.63	10.0	0.70	11.2	0.74	11.6	0.75	13.0	0.79
MUZ-GE12NA	75	6.3	0.69	8.4	0.87	10.4	1.02	12.5	1.14	14.0	1.20	14.5	1.22	16.4	1.26
	70	6.8	0.66	8.9	0.84	10.8	1.00	12.7	1.11	14.4	1.17	14.8	1.19	16.8	1.24
	65	7.2	0.63	9.1	0.81	11.3	0.97	13.2	1.08	14.8	1.14	15.3	1.16	17.1	1.22
MUZ-GE15NA	75	7.9	0.63	10.4	0.79	13.1	0.93	15.6	1.03	17.6	1.09	18.1	1.10	20.5	1.14
	70	8.6	0.60	11.1	0.76	13.5	0.91	15.9	1.01	18.0	1.06	18.5	1.08	21.0	1.12
	65	9.0	0.57	11.3	0.73	14.1	0.87	16.5	0.98	18.5	1.03	19.1	1.05	21.4	1.10
MUZ-GE18NA	75	9.1	0.64	11.9	0.81	14.9	0.95	17.8	1.06	20.1	1.12	20.7	1.13	23.5	1.18
	70	9.8	0.62	12.7	0.78	15.5	0.93	18.2	1.04	20.6	1.09	21.2	1.11	24.0	1.16
	65	10.3	0.59	13.0	0.75	16.2	0.90	18.8	1.01	21.2	1.06	21.8	1.08	24.5	1.13
MUZ-GE24NA	75	12.1	1.38	16.0	1.74	20.0	2.05	23.9	2.28	26.9	2.40	27.7	2.43	31.5	2.53
	70	13.1	1.32	17.0	1.68	20.7	2.00	24.4	2.22	27.6	2.34	28.4	2.39	32.2	2.48
	65	13.8	1.26	17.4	1.61	21.7	1.93	25.3	2.16	28.4	2.28	29.3	2.32	32.8	2.43

NOTE: 1. IDB: Intake air dry-bulb temperature
 TC: Total Capacity (x10³Btu/h)
 TPC: Total Power Consumption (kW)
 2. Above data is for heating operation without any frost.

How to operate with fixed operational frequency of the compressor.

1. Press the EMERGENCY OPERATION switch on the front of the indoor unit, and select either EMERGENCY COOL mode or EMERGENCY HEAT mode before starting to operate the air conditioner.
2. The compressor starts with operational frequency.
3. The fan speed of the indoor unit is High.
4. This operation continues for 30 minutes.
5. In order to release this operation, press the EMERGENCY OPERATION switch twice or once, or press any button on the remote controller.

7-2. PERFORMANCE CURVE

Cooling

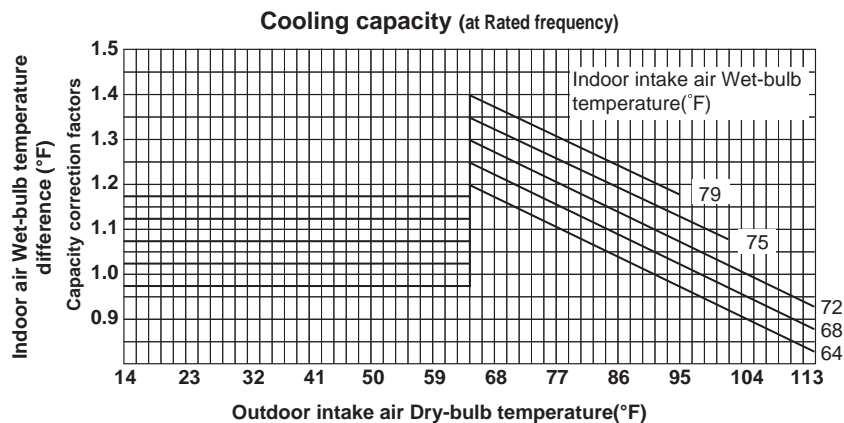

MUZ-GE09NA MUY-GE09NA

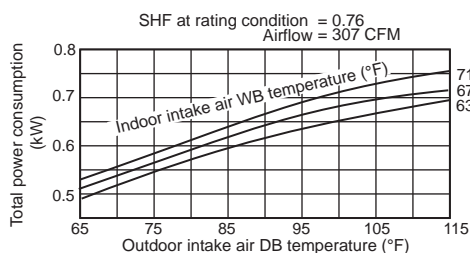

MUZ-GE12NA MUY-GE12NA

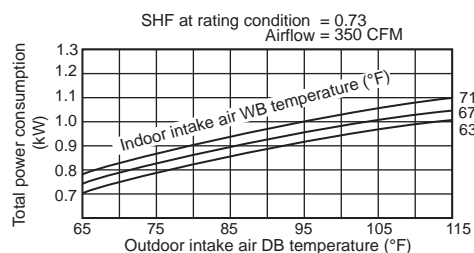

MUZ-GE15NA
MUY-GE15NA

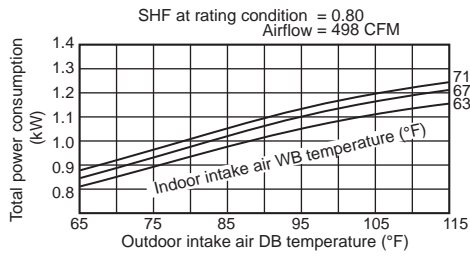

MUZ-GE18NA
MUY-GE18NA

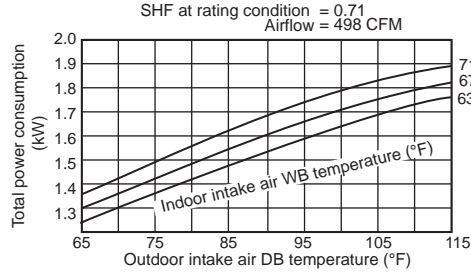

MUZ-GE24NA
MUY-GE24NA

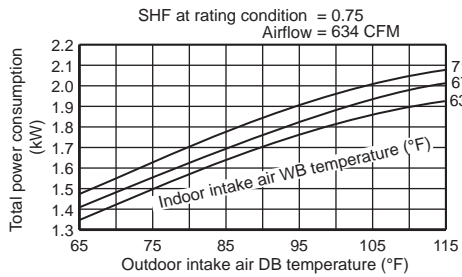

Heating (MUZ)

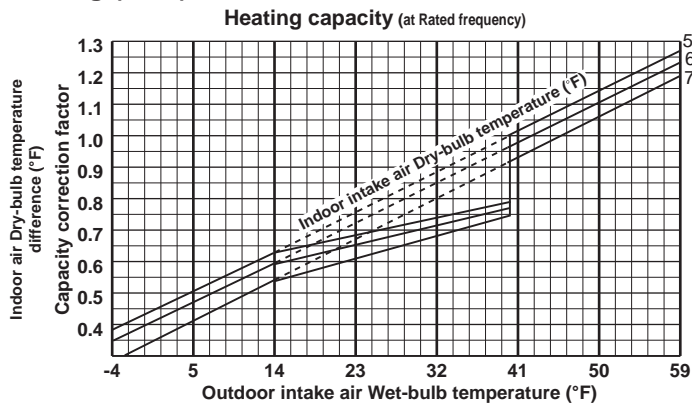

MUZ-GE09NA

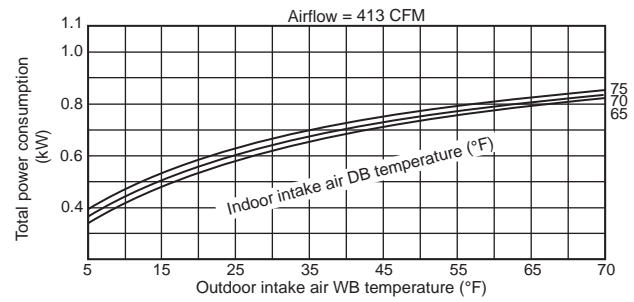

MUZ-GE12NA

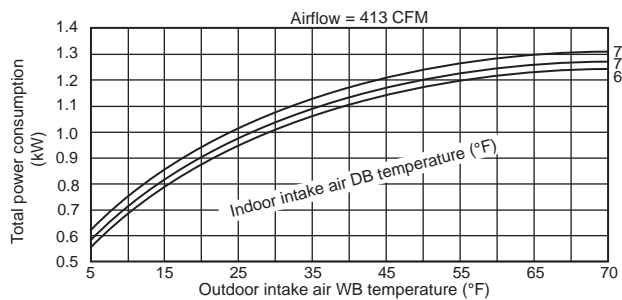

MUZ-GE15NA

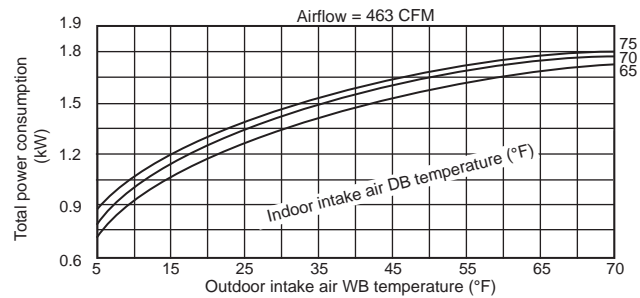

This value of frequency is not the same as the actual frequency in operating. Refer to 7-5 and 7-6 for the relationships between frequency and capacity.

MUZ-GE18NA

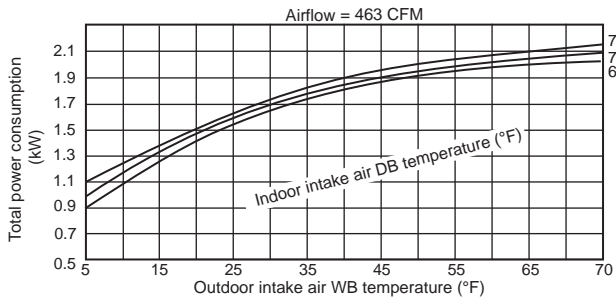

MUZ-GE24NA

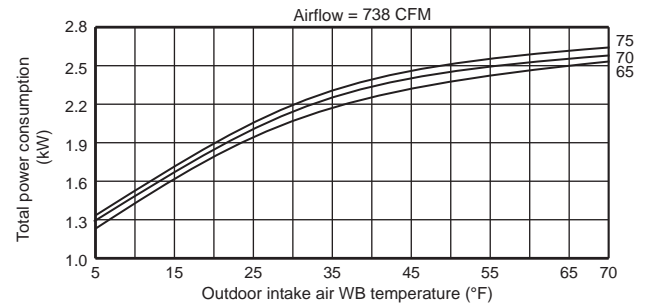

This value of frequency is not the same as the actual frequency in operating. Refer to 7-5 and 7-6 for the relationships between frequency and capacity.

7-3. CONDENSING PRESSURE

Cooling

Data is based on the condition of indoor humidity 50 %.
Air flow should be set to High speed.

MUZ-GE09NA MUY-GE09NA

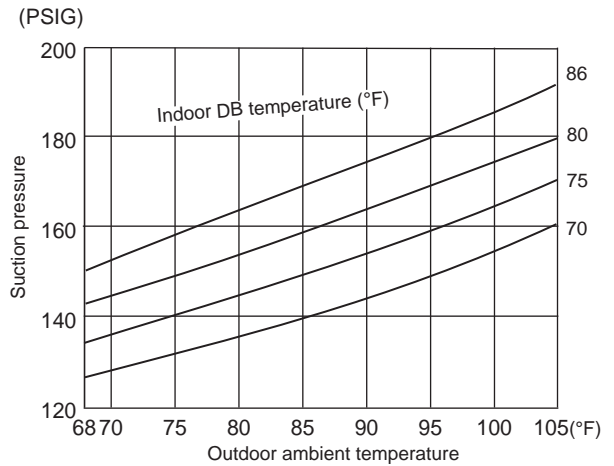
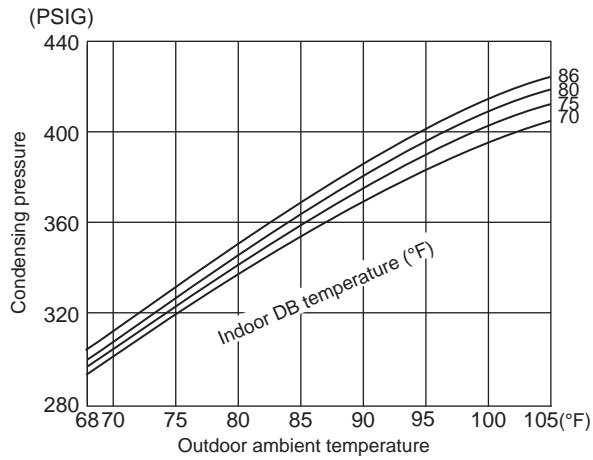

MUZ-GE12NA MUY-GE12NA

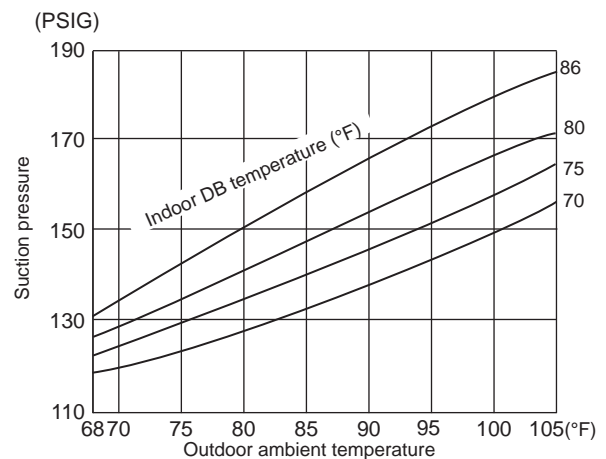
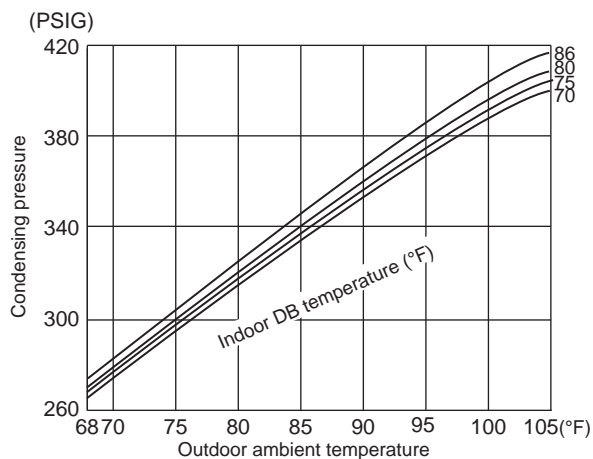

MUZ-GE15NA MUY-GE15NA

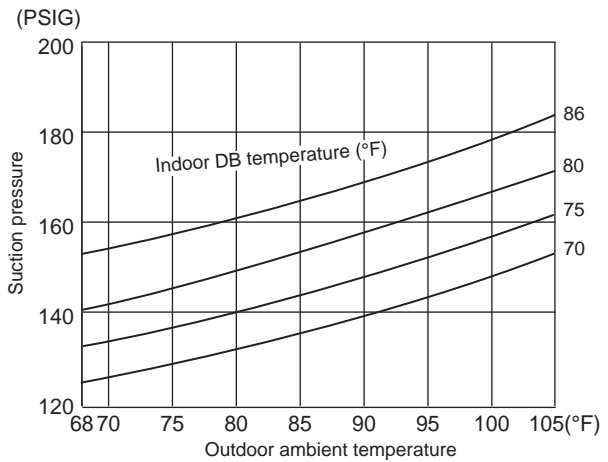
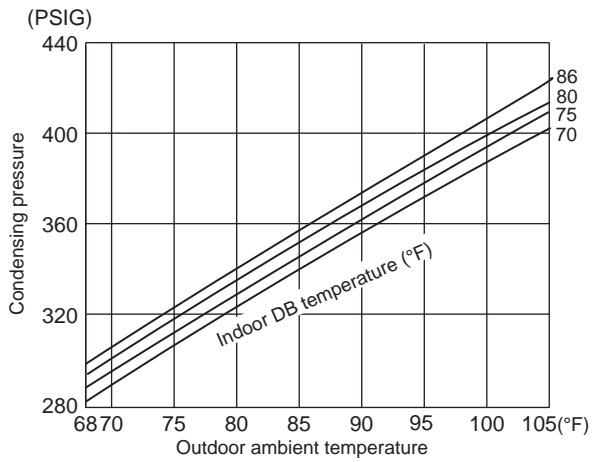

MUZ-GE18NA MUY-GE18NA

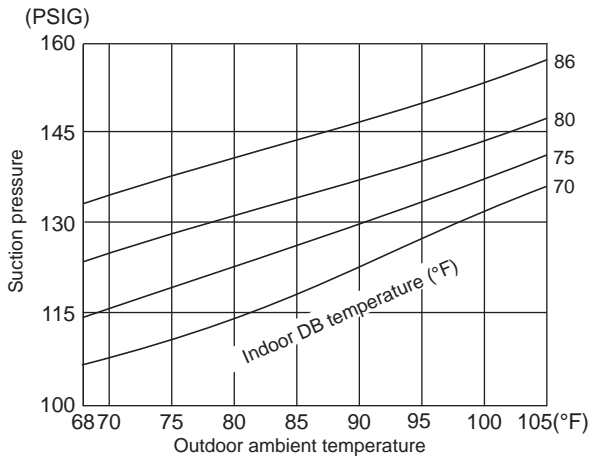
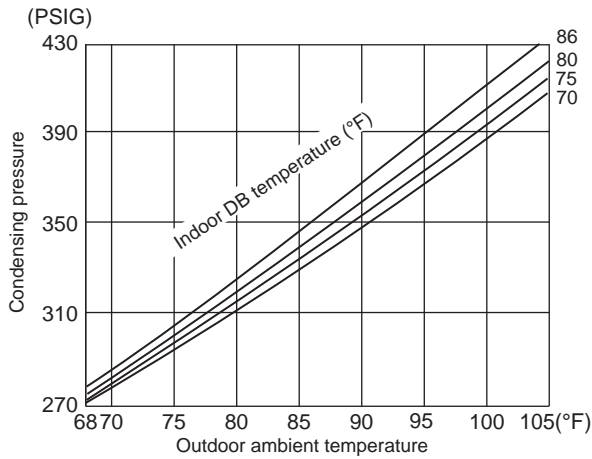

MUZ-GE24NA MUY-GE24NA

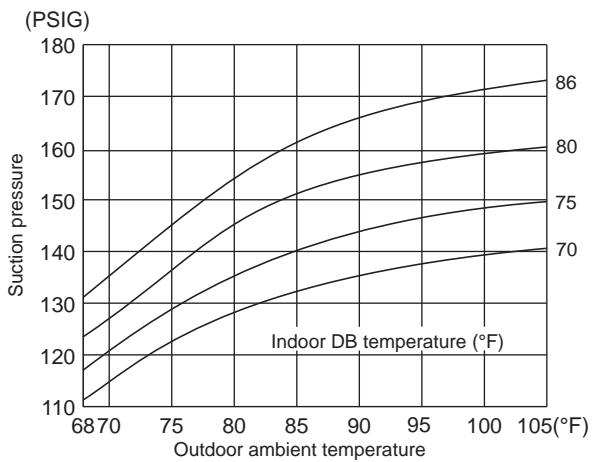
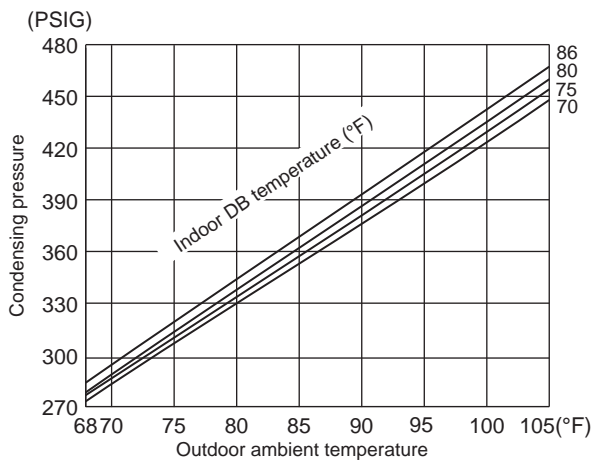

Heating (MUZ)

Data is based on the condition of outdoor humidity 75%.
Air flow should be set to High speed.
Data is for heating operation without any frost.

MUZ-GE09NA

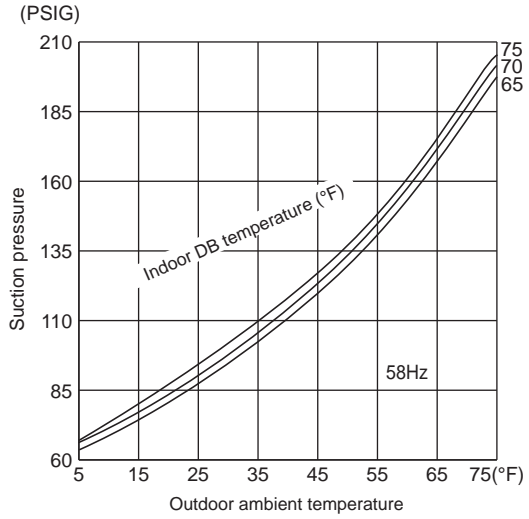
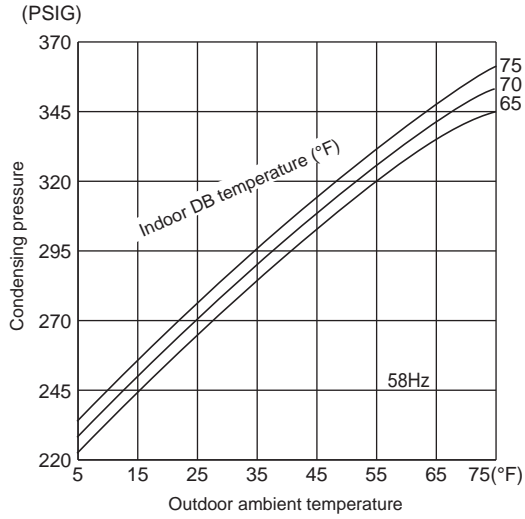

MUZ-GE12NA

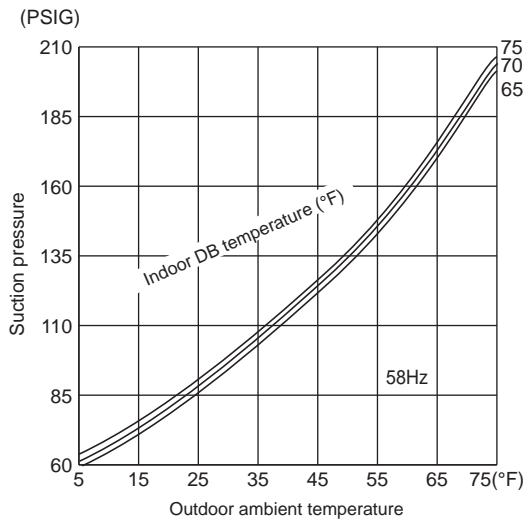
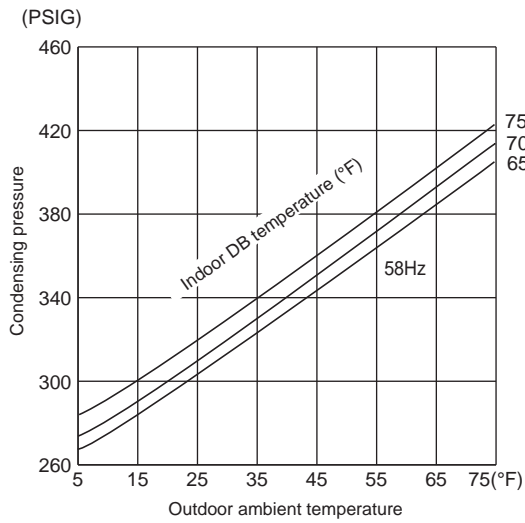

MUZ-GE15NA

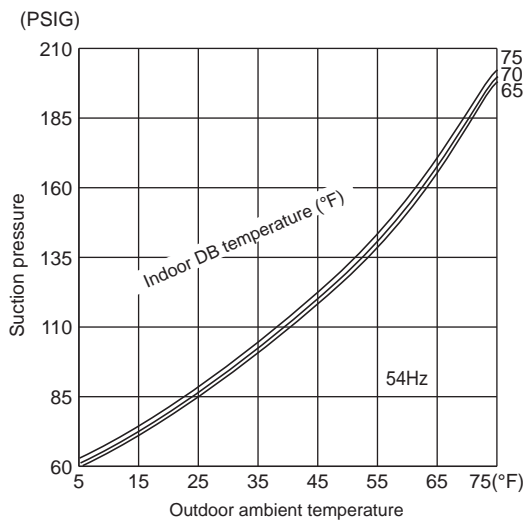
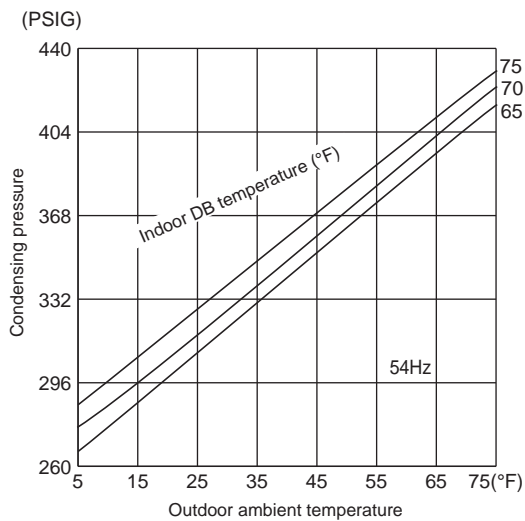

MUZ-GE18NA

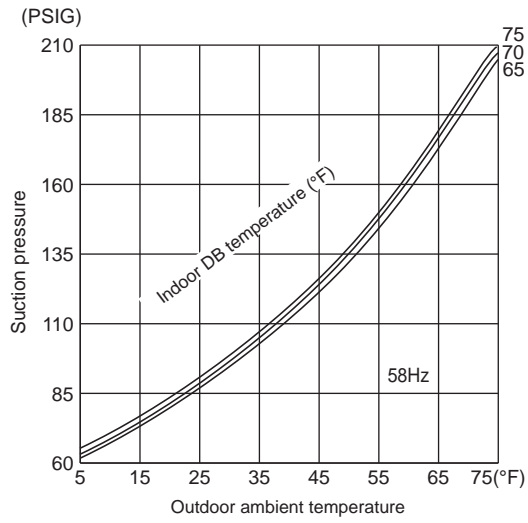
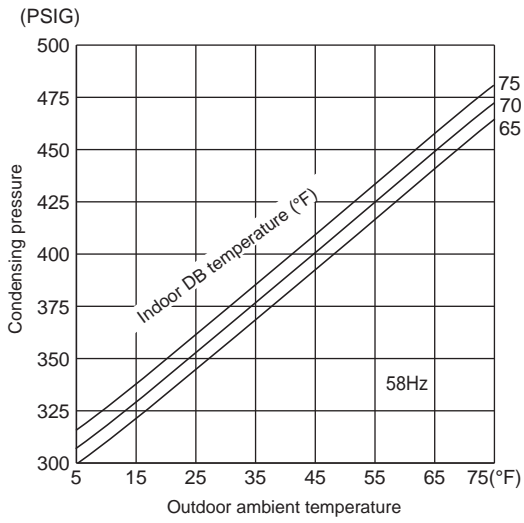

MUZ-GE24NA

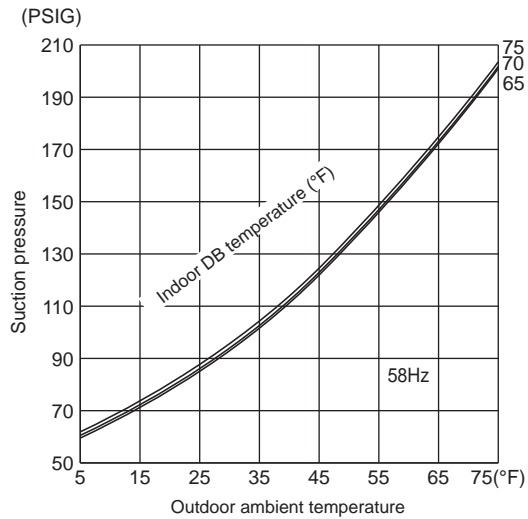
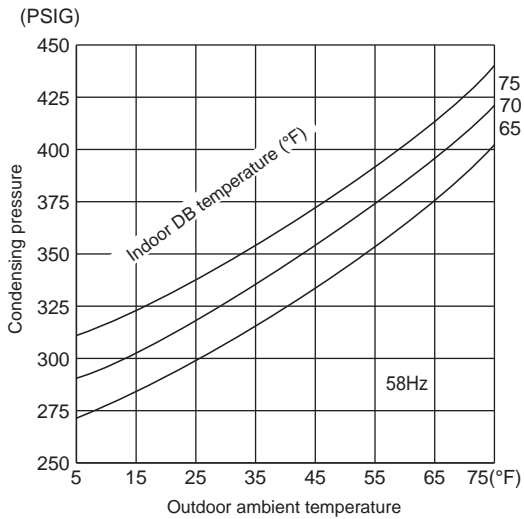

7-4. STANDARD OPERATION DATA

Model			MSZ-GE09NA MSY-GE09NA	MSZ-GE09NA	MSZ-GE12NA MSY-GE12NA	MSZ-GE12NA	
Item		Unit	Cooling	Heating	Cooling	Heating	
Total	Capacity	Btu/h	9,000	10,900	12,000	14,400	
	SHF	-	0.82	—	0.74	—	
	Input	kW	0.660	0.760	0.960	1.170	
	Rated frequency	Hz	59.5	77.5	69.0	77.0	
Indoor unit			MSZ-GE09NA, MSY-GE09NA		MSZ-GE12NA, MSY-GE12NA		
Power supply (V, Phase, Hz)			208 / 230, 1, 60				
Electrical circuit	Input	kW	0.022	0.023	0.022	0.023	
	Fan motor current	A	0.24/0.22	0.25/0.23	0.24/0.22	0.25/0.23	
	Outdoor unit			MUZ-GE09NA MUY-GE09NA	MUZ-GE09NA	MUZ-GE12NA MUY-GE12NA	MUZ-GE12NA
	Power supply (V, phase, Hz)			208/230, 1, 60			
	Input	kW	0.638	0.737	0.938	1.147	
	Comp. current	A	3.32/3.00	3.66/3.31	4.39/3.97	5.41/4.89	
	Fan motor current	A	0.27/0.24	0.30/0.27	0.34/0.31	0.31/0.28	
Refrigerant circuit	Condensing pressure	PSIG	389	331	389	397	
	Suction pressure	PSIG	151	103	133	104	
	Discharge temperature	°F	154	152	163	162	
	Condensing temperature	°F	115	103	115	116	
	Suction temperature	°F	59	39	56	35	
	Comp. shell bottom temp	°F	151	149	158	158	
	Ref. pipe length	ft.	25				
Refrigerant charge (R410A)		-	1 lb. 12 oz.		2 lb. 9 oz.		
Indoor unit	Intake air temperature	DB	°F	80	70	80	70
		WB	°F	67	60	67	60
	Discharge air temperature	DB	°F	60	97	56	108
		WB	°F	58	—	55	—
	Fan speed (High)	rpm	1,020	1,040	1,020	1,040	
Airflow (High)	CFM	367 (Wet)	413	367 (Wet)	413		
Outdoor unit	Intake air temperature	DB	°F	95	47	95	47
		WB	°F	—	43	—	43
	Fan speed	rpm	800	850	900	860	
	Airflow	CFM	1151	1225	1229	1172	



Model		MSZ-GE15NA MSY-GE15NA	MSZ-GE15NA	MSZ-GE18NA MSY-GE18NA	MSZ-GE18NA		
Item	Unit	Cooling	Heating	Cooling	Heating		
Total	Capacity	Btu/h	14,000	18,000	17,200	21,600	
	SHF	-	0.80	—	0.71	—	
	Input	kW	1.080	1.600	1.640	1.900	
	Rated frequency	Hz	55.5	74.0	83.0	84.0	
Indoor unit		MSZ-GE15NA, MSY-GE15NA		MSZ-GE18NA, MSY-GE18NA			
Power supply (V, Phase, Hz)		208/230, 1, 60					
Electrical circuit	Input	kW	0.045	0.031	0.043	0.037	
	Fan motor current	A	0.50/0.45	0.35/0.32	0.43/0.39	0.40/0.36	
	Outdoor unit		MUZ-GE15NA MUY-GE15NA	MUZ-GE15NA	MUZ-GE18NA MUY-GE18NA	MUZ-GE18NA	
	Power supply (V, phase, Hz)		208/ 230, 1, 60				
	Input	kW	1,035	1,569	1,595	1,860	
	Comp. current	A	4.86/4.40	7.38/6.67	6.97/6.29	8.36/7.55	
	Fan motor current	A	0.33/0.30	0.34/0.31	0.80/0.72	0.64/0.59	
Refrigerant circuit	Condensing pressure	PSIG	400	431	376	458	
	Suction pressure	PSIG	139	99	117	102	
	Discharge temperature	°F	164	179	177	184	
	Condensing temperature	°F	117	122	112	127	
	Suction temperature	°F	57	31	59	33	
	Comp. shell bottom temp	°F	148	165	164	170	
	Ref. pipe length	ft.	25				
	Refrigerant charge (R410A)	-	2 lb. 9 oz.		3 lb. 7 oz.		
Indoor unit	Intake air temperature	DB	°F	80	70	80	70
		WB	°F	67	60	67	60
	Discharge air temperature	DB	°F	60	114	56	117
		WB	°F	57	—	54	—
	Fan speed (High)	rpm	1,280	1,140	1,280	1,240	
Airflow (High)	CFM	498 (Wet)	463	498 (Wet)	512		
Outdoor unit	Intake air temperature	DB	°F	95	47	95	47
		WB	°F	—	43	—	43
	Fan speed	rpm	910	900	780	740	
	Airflow	CFM	1,243	1,229	1,730	1,659	

Model			MSZ-GE24NA MSY-GE24NA	MSZ-GE24NA	
Item		Unit	Cooling	Heating	
Total	Capacity	Btu/h	22,500	27,600	
	SHF	-	0.75	—	
	Input	kW	1.800	2.340	
	Rated frequency	Hz	66.5	82.0	
Electrical circuit	Indoor unit		MSZ-GE24NA, MSY-GE24NA		
	Power supply (V, Phase, Hz)		208/230, 1, 60		
	Input	kW	0.058		
	Fan motor current	A	0.56/0.51		
	Outdoor unit		MUZ-GE24NA MUY-GE24NA	MUZ-GE24NA	
	Power supply (V, phase, Hz)		208/230, 1, 60		
	Input	kW	1.742	2.282	
	Comp. current	A	7.01/6.34	9.59/8.67	
	Fan motor current	A	1.61/1.05	1.13/1.02	
	Refrigerant circuit	Condensing pressure	PSIG	395	405
Suction pressure		PSIG	141	102	
Discharge temperature		°F	158	171	
Condensing temperature		°F	115		
Suction temperature		°F	52	33	
Comp. shell bottom temp		°F	140	148	
Ref. pipe length		ft.	25		
Refrigerant charge (R410A)		-	4 lb. 3 oz.		
Indoor unit	Intake air temperature	DB	°F	80	70
		WB	°F	67	60
	Discharge air temperature	DB	°F	56	111
		WB	°F	53	—
	Fan speed (High)	rpm	1,300		
Airflow (High)	CFM	634 (Wet)	738		
Outdoor unit	Intake air temperature	DB	°F	95	47
		WB	°F	—	43
	Fan speed	rpm	840	810	
	Airflow	CFM	1,769	1,701	

7-5. CAPACITY AND INPUT CORRECTION BY INVERTER OUTPUT FREQUENCY

MUZ-GE09NA MUY-GE09NA

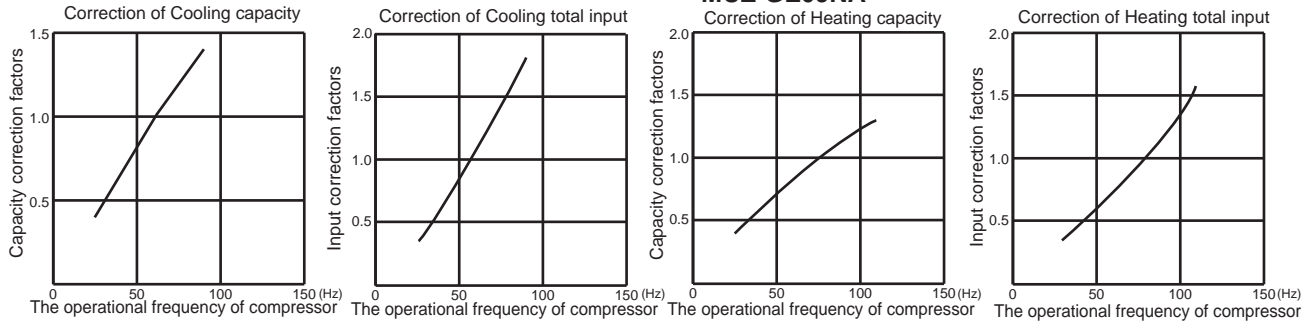

MUZ-GE12NA MUY-GE12NA

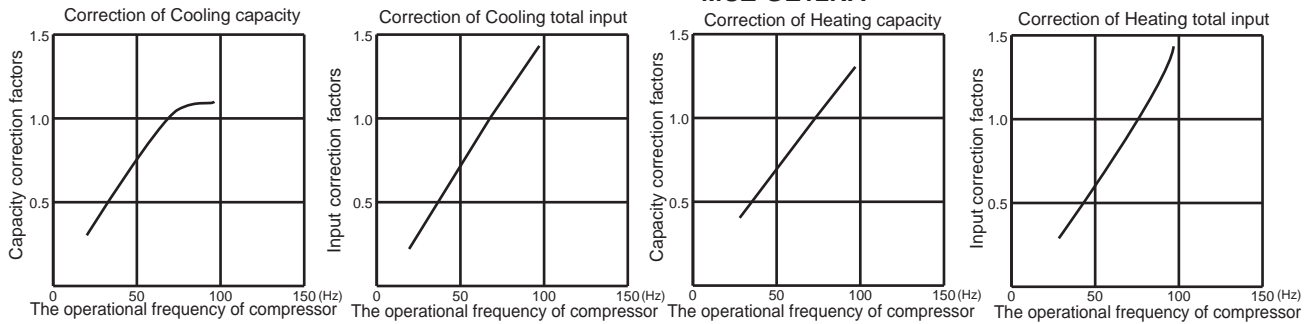

MUZ-GE15NA MUY-GE15NA

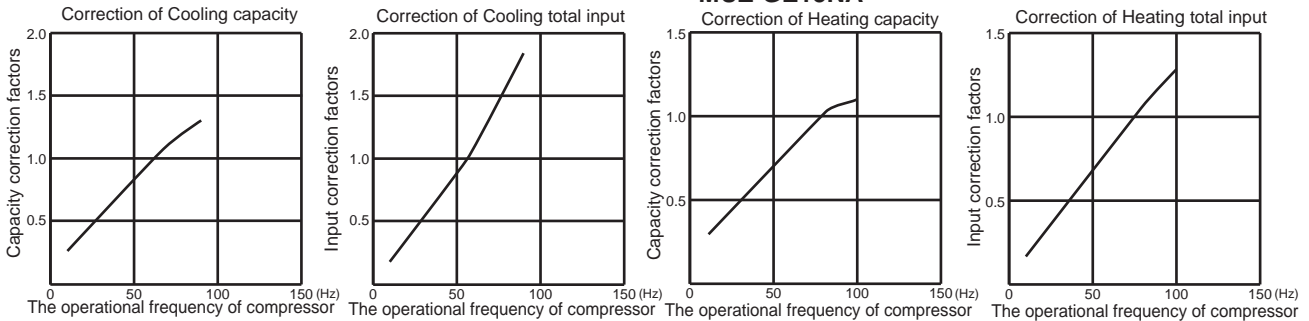

MUZ-GE18NA MUY-GE18NA

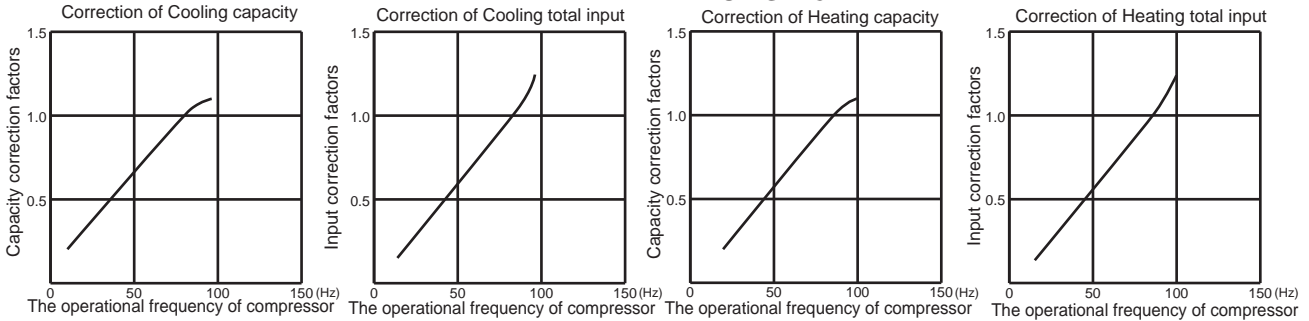

**MUZ-GE24NA
MUY-GE24NA**

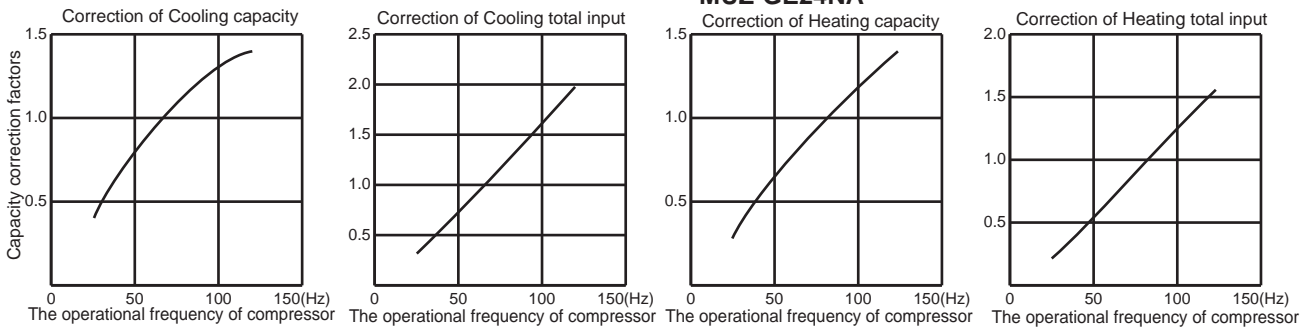

7-6. HOW TO OPERATE FIXED-FREQUENCY OPERATION (Test run operation)

1. Press EMERGENCY OPERATION switch to start COOL or HEAT mode (COOL: Press once, HEAT: Press twice).
2. Test run operation starts and continues to operate for 30 minutes.
3. Compressor operates at rated frequency in COOL mode or 58 Hz in HEAT mode.
4. Indoor fan operates at High speed.
5. After 30 minutes, test run operation finishes and EMERGENCY OPERATION starts (operation frequency of compressor varies).
6. To cancel test run operation (EMERGENCY OPERATION), press EMERGENCY OPERATION switch or any button on remote controller.

MUZ-GE09NA MUZ-GE12NA MUZ-GE15NA MUZ-GE18NA MUZ-GE24NA
MUY-GE09NA MUY-GE12NA MUY-GE15NA MUY-GE18NA MUY-GE24NA

8-1. OUTDOOR FAN MOTOR CONTROL

The fan motor turns ON/OFF, interlocking with the compressor.

[ON] The fan motor turns ON 5 seconds before the compressor starts up.

[OFF] The fan motor turns OFF 15 seconds after the compressor has stopped running.

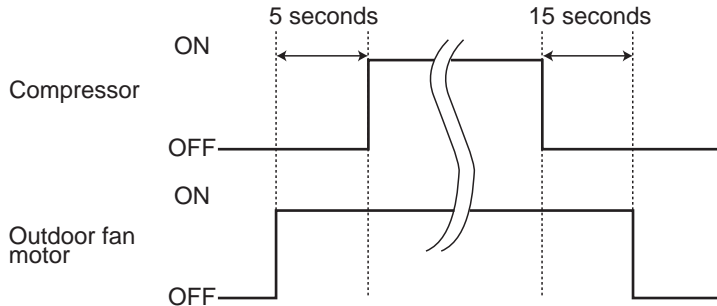

8-2. R.V. COIL CONTROL (MUZ)

Heating ON

Cooling OFF

Dry OFF

NOTE: The 4-way valve reverses for 5 seconds right before start-up of the compressor.

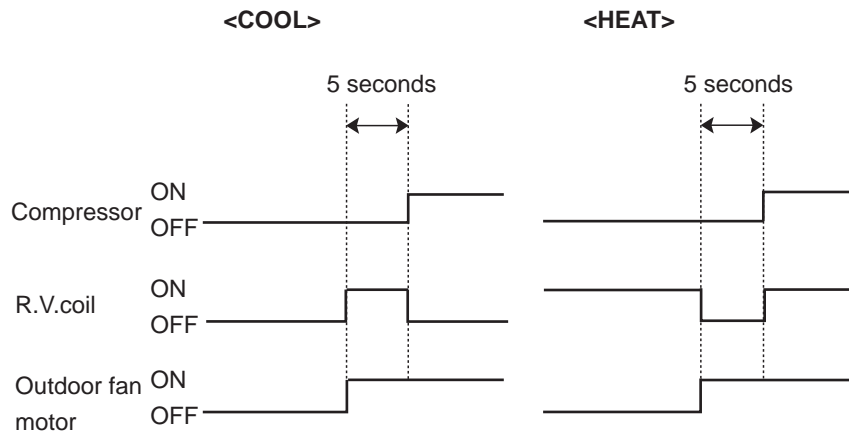

8-3. RELATION BETWEEN MAIN SENSOR AND ACTUATOR

Sensor	Purpose	Actuator				
		Compressor	LEV	Outdoor fan motor	R.V.coil (MUZ)	Indoor fan motor
Discharge temperature thermistor	Protection	○	○			
Indoor coil temperature thermistor	Cooling: Coil frost prevention	○				
	Heating: High pressure protection	○	○			
Defrost thermistor (MUZ)	Heating: Defrosting	○	○	○	○	○
Fin temperature thermistor	Protection	○		○		
Ambient temperature thermistor	Cooling: Low ambient temperature operation	○	○	○		
Outdoor heat exchanger temperature thermistor	Cooling: Low ambient temperature operation	○	○	○		
	Cooling: High pressure protection	○	○	○		

9

SERVICE FUNCTIONS

MUZ-GE09NA MUZ-GE12NA MUZ-GE15NA MUZ-GE18NA MUZ-GE24NA
 MUY-GE09NA MUY-GE12NA MUY-GE15NA MUY-GE18NA MUY-GE24NA

9-1. CHANGE IN DEFROST SETTING (MUZ)

Changing defrost finish temperature

<JS> To change the defrost finish temperature, cut/solder the JS wire of the outdoor inverter P.C. board.
 (Refer to 10-6.1.)

Jumper		Defrost finish temperature				
		MUZ-GE09	MUZ-GE12	MUZ-GE15	MUZ-GE18	MUZ-GE18/24
JS	Soldered (Initial setting)	41°F (5°C)	50°F (10°C)	41°F (5°C)	48°F (9°C)	50°F (10°C)
	None (Cut)	46°F (8°C)	55°F (13°C)	50°F (10°C)	64°F (18°C)	64°F (18°C)

9-2. PRE-HEAT CONTROL SETTING

PRE-HEAT CONTROL

When moisture gets into the refrigerant cycle, it may interfere the start-up of the compressor at low outside temperature. The pre-heat control prevents this interference. The pre-heat control turns ON when outside temperature is 68°F (20°C) or below. When pre-heat control is turned ON, compressor is energized. (About 50 W)

<JK> To activate the pre-heat control, cut the JK wire of the inverter P.C. board. (Refer to 10-6.1.)

NOTE: When the inverter P.C. board is replaced, check the Jumper wires, and cut/solder them if necessary.

10

TROUBLESHOOTING

MUZ-GE09NA MUZ-GE12NA MUZ-GE15NA MUZ-GE18NA MUZ-GE24NA
 MUY-GE09NA MUY-GE12NA MUY-GE15NA MUY-GE18NA MUY-GE24NA

10-1. CAUTIONS ON TROUBLESHOOTING

1. Before troubleshooting, check the following

- 1) Check the power supply voltage.
- 2) Check the indoor/outdoor connecting wire for miswiring.

2. Take care of the following during servicing

- 1) Before servicing the air conditioner, be sure to turn OFF the main unit first with the remote controller, then after confirming the horizontal vane is closed, turn off the breaker and/or disconnect the power plug.
- 2) Be sure to turn OFF the power supply before removing the front panel, the cabinet, the top panel, and the electronic control P.C. board.
- 3) When removing the electrical parts, be careful of the residual voltage of smoothing capacitor.
- 4) When removing the electronic control P.C. board, hold the edge of the board with care NOT to apply stress on the components.
- 5) When connecting or disconnecting the connectors, hold the housing of the connector. DO NOT pull the lead wires.

<Incorrect>

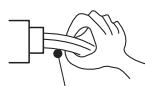

Lead wiring

<Correct>



Housing point

3. Troubleshooting procedure

- 1) First, check if the OPERATION INDICATOR lamp on the indoor unit is flashing ON and OFF to indicate an abnormality. To make sure, check how many times the OPERATION INDICATOR lamp is flashing ON and OFF before starting service work.
- 2) Before servicing, check that the connector and terminal are connected properly.
- 3) When the electronic control P.C. board seems to be defective, check the copper foil pattern for disconnection and the components for bursting and discoloration.
- 4) Refer to 10-2. and 10-3.

10-2. FAILURE MODE RECALL FUNCTION

Outline of the function

This air conditioner can memorize the abnormal condition which has occurred once.

Even though LED indication listed on the troubleshooting check table (10-3.) disappears, the memorized failure details can be recalled.

1. Flow chart of failure mode recall function for the indoor/outdoor unit

MSZ-GE06/09/12/15/18NA
MSY-GE09/12/15/18NA

MSZ-GE24NA
MSY-GE24NA

Operational procedure

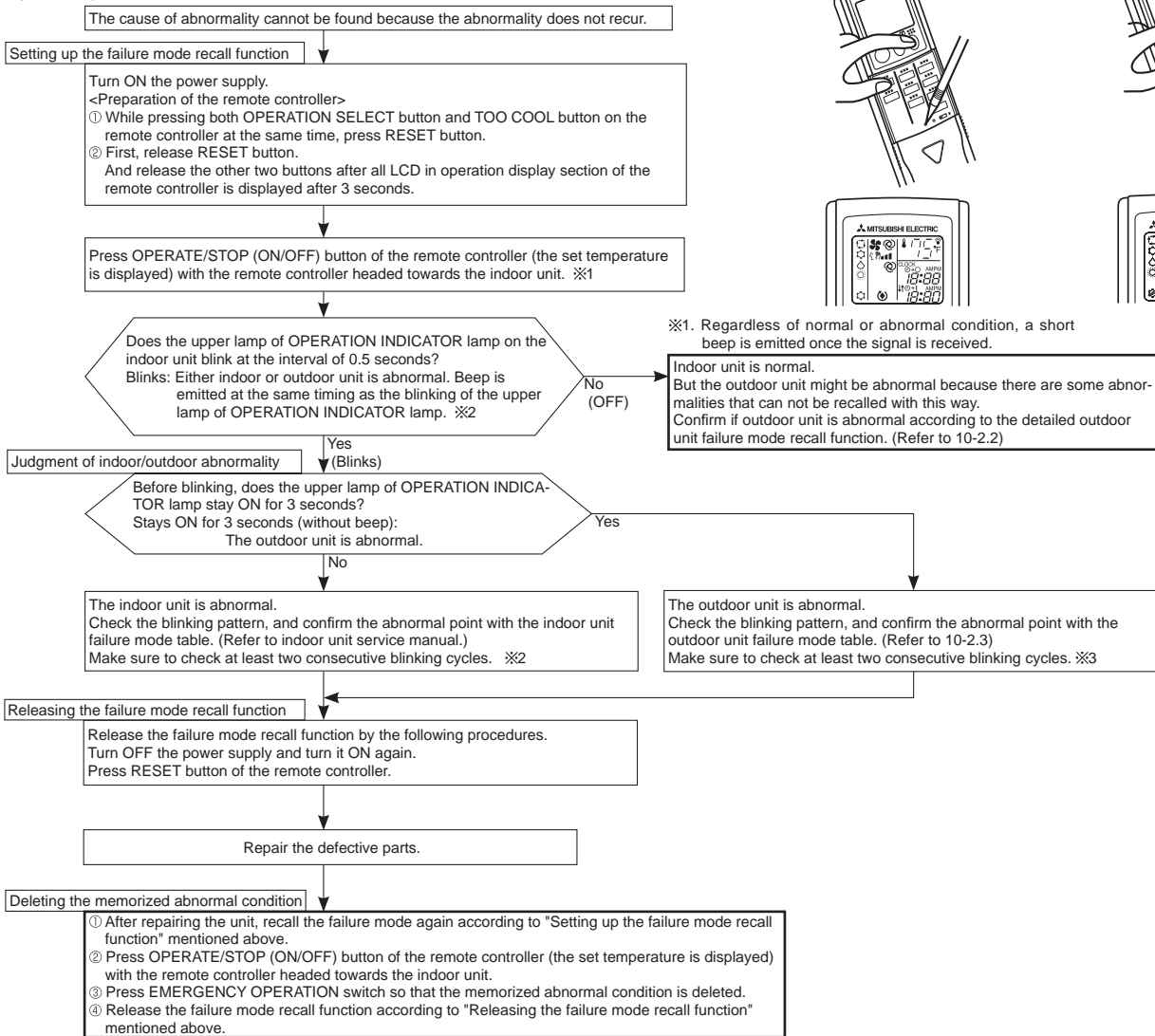

NOTE: 1. Make sure to release the failure mode recall function once it is set up, otherwise the unit cannot operate properly.
2. If the abnormal condition is not deleted from the memory, the last abnormal condition is kept memorized.

※2. Blinking pattern when the indoor unit is abnormal:

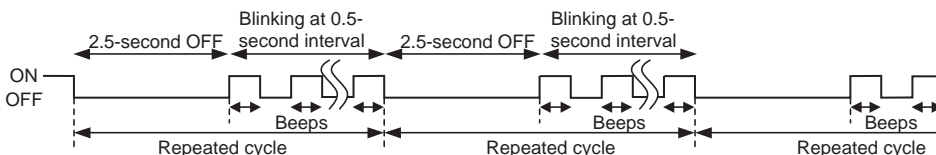

※3. Blinking pattern when the outdoor unit is abnormal:

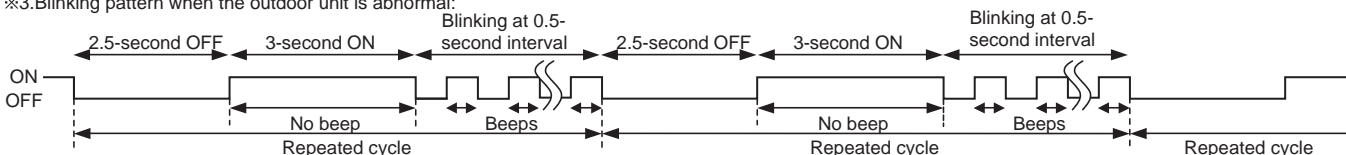

2. Flow chart of the detailed outdoor unit failure mode recall function

Operational procedure

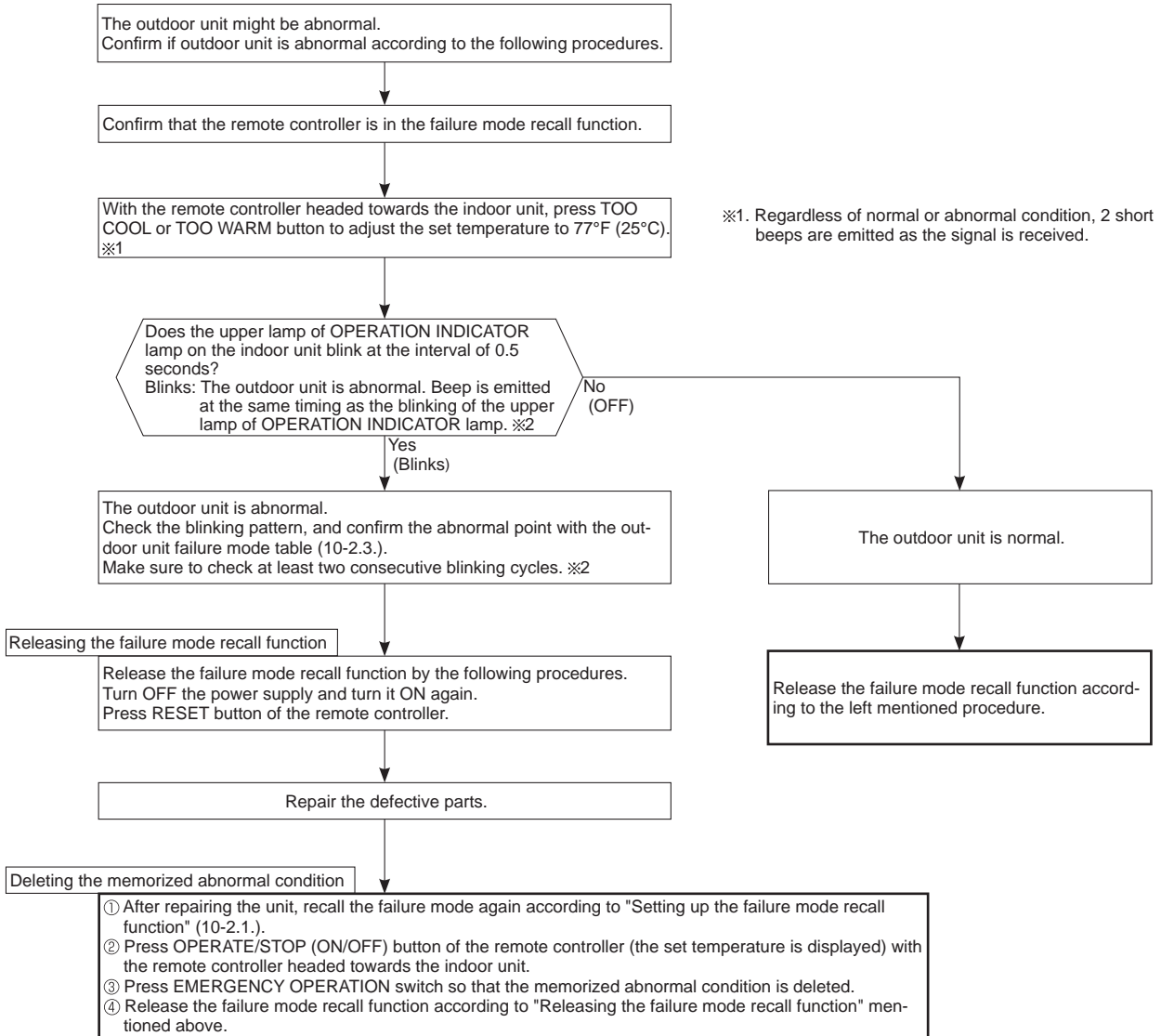

NOTE: 1. Make sure to release the failure mode recall function once it is set up, otherwise the unit cannot operate properly.
2. If the abnormal condition is not deleted from the memory, the last abnormal condition is kept memorized.

※2. Blinking pattern when outdoor unit is abnormal:

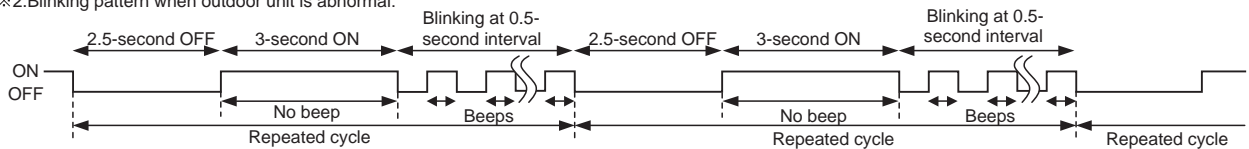

3. Outdoor unit failure mode table

OPERATION INDICATOR upper lamp (Indoor unit)	Abnormal point (Failure mode / protection)	LED indication (Outdoor P.C. board)	Condition	Remedy	Indoor/ outdoor unit failure mode recall function	Outdoor unit failure mode recall function
OFF	None (Normal)	—	—	—	—	—
2-time flash 2.5 seconds OFF	Outdoor power system	—	Overcurrent protection stop is continuously performed 3 times within 1 minute after the compressor gets started.	<ul style="list-style-type: none"> •Reconnect connectors. •Refer to 10-5. Ⓐ"How to check inverter/ compressor". •Check stop valve. 	○	○
3-time flash 2.5 seconds OFF	Discharge temperature thermistor	1-time flash every 2.5 seconds	Thermistor shorts or opens during compressor running.	<ul style="list-style-type: none"> •Refer to 10-5. Ⓒ"Check of outdoor thermistors". Defective outdoor thermistors can be identified by checking the blinking pattern of LED. 	○	○
	Defrost thermistor (MUZ)					
	Fin temperature thermistor	3-time flash 2.5 seconds OFF				
	P.C. board temperature thermistor	4-time flash 2.5 seconds OFF				
	Ambient temperature thermistor	2-time flash 2.5 seconds OFF				
Outdoor heat exchanger temperature thermistor (MUZ/MUY-GE24NA)						
4-time flash 2.5 seconds OFF	Overcurrent	11-time flash 2.5 seconds OFF	Large current flows into intelligent power module.	<ul style="list-style-type: none"> •Reconnect compressor connector. •Refer to 10-5. Ⓐ"How to check inverter/ compressor". •Check stop valve. 	—	○
	Compressor synchronous abnormality (Compressor start-up failure protection)	12-time flash 2.5 seconds OFF	Waveform of compressor current is distorted.	<ul style="list-style-type: none"> •Reconnect compressor connector. •Refer to 10-5. Ⓐ"How to check inverter/ compressor". 	—	○
5-time flash 2.5 seconds OFF	Discharge temperature	—	Temperature of discharge temperature thermistor exceeds 241°F (116°C), compressor stops. Compressor can restart if discharge temperature thermistor reads 212°F (100°C) or less 3 minutes later.	<ul style="list-style-type: none"> •Check refrigerant circuit and refrigerant amount. •Refer to 10-5. Ⓒ"Check of LEV". 	—	○
6-time flash 2.5 seconds OFF	High pressure	—	Temperature of indoor coil thermistor exceeds 158°F (70°C) in HEAT mode (MUZ only). Temperature of outdoor heat exchanger temperature thermistor exceeds 158°F (70°C) in COOL mode.	<ul style="list-style-type: none"> •Check refrigerant circuit and refrigerant amount. •Check stop valve. 	—	○
7-time flash 2.5 seconds OFF	Fin temperature/ P.C. board temperature	7-time flash 2.5 seconds OFF	Temperature of fin temperature thermistor on the inverter P.C. board exceeds 167 ~ 176°F (75 ~ 80°C), or temperature of P.C. board temperature thermistor on the inverter P.C. board exceeds 158 ~ 167°F (70 ~ 75°C).	<ul style="list-style-type: none"> •Check around outdoor unit. •Check outdoor unit air passage. •Refer to 10-5. Ⓓ"Check of outdoor fan motor". 	—	○
8-time flash 2.5 seconds OFF	Outdoor fan motor	—	Outdoor fan has stopped 3 times in a row within 30 seconds after outdoor fan start-up.	<ul style="list-style-type: none"> •Refer to 10-5. Ⓓ"Check of outdoor fan motor". Refer to 10-5. Ⓓ"Check of inverter P.C. board". 	—	○
9-time flash 2.5 seconds OFF	Nonvolatile memory data	5-time flash 2.5 seconds OFF	Nonvolatile memory data cannot be read properly.	<ul style="list-style-type: none"> •Replace the inverter P.C. board. 	○	○
	Power module (MUZ/MUY-GE24NA)	6-time flash 2.5 seconds OFF	The interphase short circuit occurs in the output of the intelligent power module (IPM). The compressor winding shorts circuit.	<ul style="list-style-type: none"> •Refer to 10-5. Ⓐ"How to check inverter/ compressor". 		
10-time flash 2.5 seconds OFF	Discharge temperature	—	Temperature of discharge temperature thermistor has been 122°F (50°C) or less for 20 minutes.	<ul style="list-style-type: none"> •Refer to 10-5. Ⓒ"Check of LEV". •Check refrigerant circuit and refrigerant amount. 	—	○
11-time flash 2.5 seconds OFF	DC voltage	8-time flash 2.5 seconds OFF	DC voltage of inverter cannot be detected normally.	<ul style="list-style-type: none"> •Refer to 10-5. Ⓐ"How to check inverter/ compressor". 	—	○
	Each phase current of compressor	9-time flash 2.5 seconds OFF	Each phase current of compressor cannot be detected normally.			
12-time flash 2.5 seconds OFF	Overcurrent Compressor open-phase	10-time flash 2.5 seconds OFF	Large current flows into intelligent power module (IPM). The open-phase operation of compressor is detected. The interphase short circuit occurs in the output of the intelligent power module (IPM). The compressor winding shorts circuit.	<ul style="list-style-type: none"> •Reconnect compressor connector. •Refer to 10-5. Ⓐ"How to check inverter/ compressor". 	—	○
14-time flash 2.5 seconds OFF	Stop valve (Closed valve)	14-time flash 2.5 seconds OFF	Closed valve is detected by compressor current.	<ul style="list-style-type: none"> •Check stop valve 	○	○

NOTE: Blinking patterns of this mode differ from the ones of Troubleshooting check table (10-3).

10-3. TROUBLESHOOTING CHECK TABLE

No.	Symptom	LED indication	Abnormal point/Condition	Condition	Remedy
1	Outdoor unit does not operate.	1-time flash every 2.5 seconds	Outdoor power system	Overcurrent protection stop is continuously performed 3 times within 1 minute after the compressor gets started, or failure of restart of compressor has repeated 24 times.	<ul style="list-style-type: none"> •Reconnect connector of compressor. •Refer to 10-5.Ⓐ "How to check inverter/compressor". •Check stop valve.
2			Outdoor thermistors	Discharge temperature thermistor, fin temperature thermistor, defrost thermistor, outdoor heat exchanger temperature thermistor, P.C. board temperature thermistor or ambient temperature thermistor shorts or opens during compressor running.	•Refer to 10-5.Ⓒ "Check of outdoor thermistors".
3			Outdoor control system	Nonvolatile memory data cannot be read properly. (The upper lamp of OPERATION INDICATOR of the indoor unit lights up or flashes 7 times.)	•Replace inverter P.C. board.
4		6-time flash 2.5 seconds OFF	Serial signal	The communication fails between the indoor and outdoor unit for 3 minutes.	•Refer to 10-5.Ⓓ "How to check miswiring and serial signal error."
5		11-time flash 2.5 seconds OFF	Stop valve/ Closed valve	Closed valve is detected by compressor current.	•Check stop valve.
6		14-time flash 2.5 seconds OFF	Outdoor unit (Other abnormality)	Outdoor unit is defective.	•Refer to 10-2.2. "Flow chart of the detailed outdoor unit failure mode recall function".
7	Outdoor unit stops and re-starts 3 minutes later' is repeated.	2-time flash 2.5 seconds OFF	Overcurrent protection	Large current flows into intelligent power module. ※ When overcurrent protection occurs within 10 seconds after compressor starts, compressor restarts after 15 seconds (MUZ-GE09/12/15/18NA, MUY-GE09/12/15/18NA).	<ul style="list-style-type: none"> •Reconnect connector of compressor. •Refer to 10-5.Ⓐ "How to check inverter/compressor". •Check stop valve.
8		3-time flash 2.5 seconds OFF	Discharge temperature overheat protection	Temperature of discharge temperature thermistor exceeds 241°F (116°C), compressor stops. Compressor can restart if discharge temperature thermistor reads 212°F (100°C) or less 3 minutes later.	<ul style="list-style-type: none"> •Check refrigerant circuit and refrigerant amount. •Refer to 10-5.Ⓒ "Check of LEV".
9		4-time flash 2.5 seconds OFF	Fin temperature /P.C. board temperature thermistor overheat protection	Temperature of fin temperature thermistor on the heat sink exceeds 167 ~ 176°F (75 ~ 80°C) or temperature of P.C. board temperature thermistor on the inverter P.C. board exceeds 158 ~ 167°F (70 ~ 75°C).	<ul style="list-style-type: none"> •Check around outdoor unit. •Check outdoor unit air passage. •Refer to 10-5.Ⓓ "Check of outdoor fan motor".
10		5-time flash 2.5 seconds OFF	High pressure protection	Temperature of indoor coil thermistor exceeds 158°F (70°C) in HEAT mode (MUZ only). Temperature of outdoor heat exchanger temperature thermistor exceeds 158°F (70°C) in COOL mode.	<ul style="list-style-type: none"> •Check refrigerant circuit and refrigerant amount. •Check stop valve.
11		8-time flash 2.5 seconds OFF	Compressor synchronous abnormality	The waveform of compressor current is distorted.	<ul style="list-style-type: none"> •Reconnect connector of compressor. •Refer to 10-5.Ⓐ "How to check inverter/compressor".
12		10-time flash 2.5 seconds OFF	Outdoor fan motor	Outdoor fan has stopped 3 times in a row within 30 seconds after outdoor fan start-up.	<ul style="list-style-type: none"> •Refer to 10-5.Ⓓ "Check of outdoor fan motor." •Refer to 10-5.Ⓒ "Check of inverter P.C. board."
13		12-time flash 2.5 seconds OFF	Each phase current of compressor	Each phase current of compressor cannot be detected normally.	•Refer to 10-5.Ⓐ "How to check inverter/compressor".
14		13-time flash 2.5 seconds OFF	DC voltage	DC voltage of inverter cannot be detected normally.	•Refer to 10-5.Ⓐ "How to check inverter/compressor".
15	Outdoor unit operates.	1-time flash 2.5 seconds OFF	Frequency drop by current protection	Current from power outlet is nearing Max. fuse size.	The unit is normal, but check the following.
16		3-time flash 2.5 seconds OFF	Frequency drop by high pressure protection	Temperature of indoor coil thermistor exceeds 131°F (55°C) in HEAT mode, compressor frequency lowers.	<ul style="list-style-type: none"> •Check if indoor filters are clogged. •Check if refrigerant is short. •Check if indoor/outdoor unit air circulation is short cycled.
17			Frequency drop by defrosting in COOL mode	Indoor coil thermistor reads 46°F (8°C) or less in COOL mode, compressor frequency lowers.	
18	Outdoor unit operates.	4-time flash 2.5 seconds OFF	Frequency drop by discharge temperature protection	Temperature of discharge temperature thermistor exceeds 232°F (111°C), compressor frequency lowers.	<ul style="list-style-type: none"> •Check refrigerant circuit and refrigerant amount. •Refer to 10-5.Ⓒ "Check of LEV". •Refer to 10-5.Ⓒ "Check of outdoor thermistors".
19		7-time flash 2.5 seconds OFF	Low discharge temperature protection	Temperature of discharge temperature thermistor has been 122°F (50°C) or less for 20 minutes.	<ul style="list-style-type: none"> •Refer to 10-5.Ⓒ "Check of LEV". •Check refrigerant circuit and refrigerant amount.
20			8-time flash 2.5 seconds OFF	PAM protection PAM: Pulse Amplitude Modulation	The overcurrent flows into IGBT (Insulated Gate Bipolar transistor: TR821) or the bus-bar voltage reaches 320 V or more, PAM stops and restarts.
	9-time flash 2.5 seconds OFF	Zero cross detecting circuit	Zero cross signal for PAM control cannot be detected.		
		9-time flash 2.5 seconds OFF	Inverter check mode	The connector of compressor is disconnected, inverter check mode starts.	•Check if the connector of the compressor is correctly connected. Refer to 10-5.Ⓐ "How to check inverter/compressor".

NOTE: 1. The location of LED is illustrated at the right figure. Refer to 10-6.1.

2. LED is lighted during normal operation.

The flashing frequency shows the number of times the LED blinks after every 2.5-second OFF. Flashing (Example) When the flashing frequency is "2".

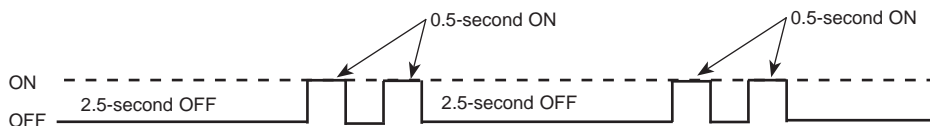

Inverter P.C. board (Parts side)



MUZ/MUY-GE24NA

Flashing → LED

MUZ/MUY-GE09/12/15/18NA

10-4. TROUBLE CRITERION OF MAIN PARTS

MUZ-GE09NA MUZ-GE12NA MUZ-GE15NA MUZ-GE18NA MUZ-GE24NA MUY-GE09NA MUY-GE12NA MUY-GE15NA MUY-GE18NA MUY-GE24NA

Part name	Check method and criterion	Figure																
Defrost thermistor (RT61) (MUZ) Fin temperature thermistor (RT64) Ambient temperature thermistor (RT65) Outdoor heat exchanger temperature thermistor (RT68)	Measure the resistance with a tester. Refer to 10-6. "Test point diagram and voltage", 1. "Inverter P.C. board", for the chart of thermistor.																	
Discharge temperature thermistor (RT62)	Measure the resistance with a tester. Before measurement, hold the thermistor with your hands to warm it up. Refer to 10-6. "Test point diagram and voltage", 1. "Inverter P.C. board", for the chart of thermistor.																	
Compressor	Measure the resistance between terminals using a tester. (Temperature: -4 ~ 104°F (-20 ~ 40°C)) <table border="1" style="margin-left: 20px;"> <thead> <tr> <th rowspan="2"></th> <th colspan="4">Normal (Ω)</th> </tr> <tr> <th>GE09</th> <th>GE12</th> <th>GE15/18</th> <th>GE24</th> </tr> </thead> <tbody> <tr> <td>U-V</td> <td rowspan="3">1.36 ~ 1.93</td> <td rowspan="3">1.52 ~ 2.17</td> <td rowspan="3">0.78 ~ 1.11</td> <td rowspan="3">0.83 ~ 1.18</td> </tr> <tr> <td>U-W</td> </tr> <tr> <td>V-W</td> </tr> </tbody> </table>		Normal (Ω)				GE09	GE12	GE15/18	GE24	U-V	1.36 ~ 1.93	1.52 ~ 2.17	0.78 ~ 1.11	0.83 ~ 1.18	U-W	V-W	
	Normal (Ω)																	
	GE09	GE12	GE15/18	GE24														
U-V	1.36 ~ 1.93	1.52 ~ 2.17	0.78 ~ 1.11	0.83 ~ 1.18														
U-W																		
V-W																		
Outdoor fan motor	Measure the resistance between lead wires using a tester. (Temperature: -4 ~ 104°F (-20 ~ 40°C)) <table border="1" style="margin-left: 20px;"> <thead> <tr> <th rowspan="2">Color of lead wire</th> <th colspan="3">Normal (Ω)</th> </tr> <tr> <th>GE09/12</th> <th>GE15</th> <th>GE18/24</th> </tr> </thead> <tbody> <tr> <td>RED - BLK</td> <td colspan="2" rowspan="3">28 ~ 40</td> <td rowspan="3">11 ~ 16</td> </tr> <tr> <td>BLK - WHT</td> </tr> <tr> <td>WHT - RED</td> </tr> </tbody> </table>	Color of lead wire	Normal (Ω)			GE09/12	GE15	GE18/24	RED - BLK	28 ~ 40		11 ~ 16	BLK - WHT	WHT - RED				
Color of lead wire	Normal (Ω)																	
	GE09/12	GE15	GE18/24															
RED - BLK	28 ~ 40		11 ~ 16															
BLK - WHT																		
WHT - RED																		
R. V. coil (21S4) (MUZ)	Measure the resistance using a tester. (Temperature: 14 ~ 104°F (-10 ~ 40°C)) <table border="1" style="margin-left: 20px;"> <thead> <tr> <th>Normal (kΩ)</th> </tr> </thead> <tbody> <tr> <td>0.97 ~ 1.38</td> </tr> </tbody> </table>	Normal (kΩ)	0.97 ~ 1.38															
Normal (kΩ)																		
0.97 ~ 1.38																		
Expansion valve coil (LEV)	Measure the resistance using a tester. (Temperature: 14 ~ 104°F (-10 ~ 40°C)) <table border="1" style="margin-left: 20px;"> <thead> <tr> <th>Color of lead wire</th> <th>Normal (Ω)</th> </tr> </thead> <tbody> <tr> <td>WHT - RED</td> <td rowspan="4">37 ~ 54</td> </tr> <tr> <td>RED - ORN</td> </tr> <tr> <td>YLW - BRN</td> </tr> <tr> <td>BRN - BLU</td> </tr> </tbody> </table>	Color of lead wire	Normal (Ω)	WHT - RED	37 ~ 54	RED - ORN	YLW - BRN	BRN - BLU										
Color of lead wire	Normal (Ω)																	
WHT - RED	37 ~ 54																	
RED - ORN																		
YLW - BRN																		
BRN - BLU																		

10-5. TROUBLESHOOTING FLOW

A How to check inverter/compressor

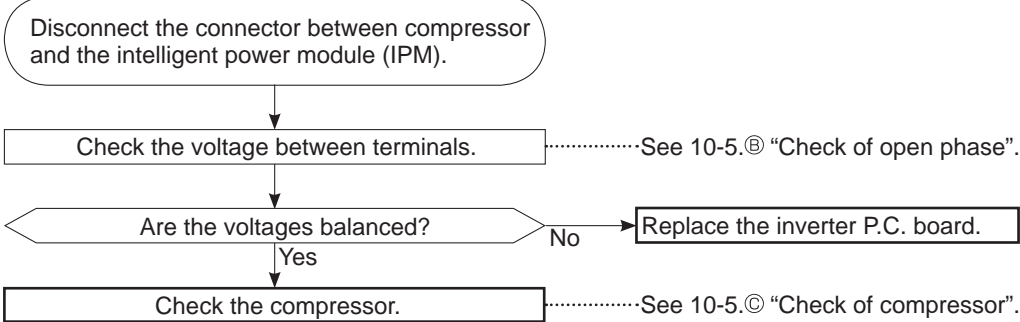

B Check of open phase

- With the connector between the compressor and the intelligent power module disconnected, activate the inverter and check if the inverter is normal by measuring the voltage balance between the terminals.

Output voltage is 50 - 130 V. (The voltage may differ according to the tester.)

<< Operation method >>

Start cooling or heating operation by pressing EMERGENCY OPERATION switch on the indoor unit. (TEST RUN OPERATION: Refer to 7-6.)

<< Measurement point >>

at 3 points

BLK (U) - WHT (V)

BLK (U) - RED (W)

WHT(V) - RED (W)

Measure AC voltage between the lead wires at 3 points.

NOTE: 1. Output voltage varies according to power supply voltage.

2. Measure the voltage by analog type tester.

3. During this check, LED of the inverter P.C. board flashes 9 times. (Refer to 10-6.1.)

C Check of compressor

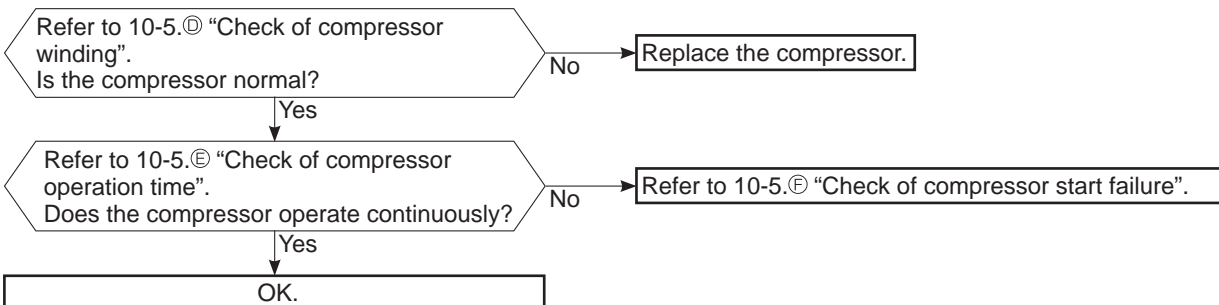

D Check of compressor winding

- Disconnect the connector between the compressor and intelligent power module, and measure the resistance between the compressor terminals.

<<Measurement point>>

at 3 points

BLK - WHT

BLK - RED

WHT - RED

※ Measure the resistance between the lead wires at 3 points.

<<Judgement>>

Refer to 10-4.

0[Ω] Abnormal [short]

Infinite [Ω] Abnormal [open]

NOTE: Be sure to zero the ohmmeter before measurement.

E Check of compressor operation time

- Connect the compressor and activate the inverter. Then measure the time until the inverter stops due to over current.

<<Operation method>>

Start heating or cooling operation by pressing EMERGENCY OPERATION switch on the indoor unit.

(TEST RUN OPERATION: Refer to 7-6.)

<<Measurement>>

Measure the time from the start of compressor to the stop of compressor due to overcurrent.

<<Judgement>>

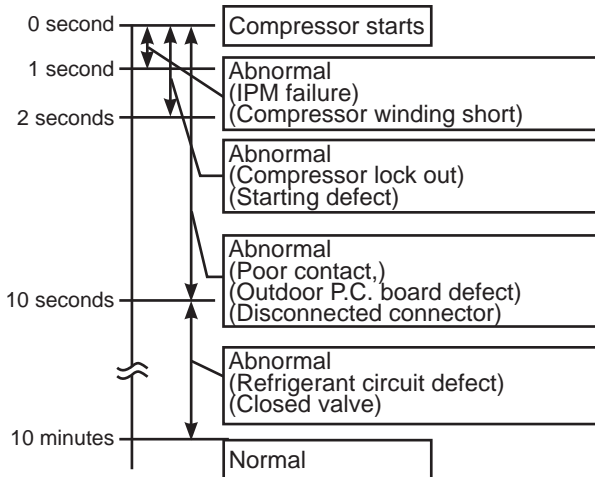

F Check of compressor start failure

Confirm that 1~4 is normal.

- Electrical circuit check

1. Contact of the compressor connector

2. Output voltage of inverter P.C. board and balance of them (See 10-5.Ⓔ)

3. Direct current voltage between DB61(+) and (-) (MUZ/MUY-GE09/12/15/18NA)/ JP715(+) and JP30(-) (MUZ/MUY-GE24NA) on the inverter P.C. board

4. Voltage between outdoor terminal block S1-S2

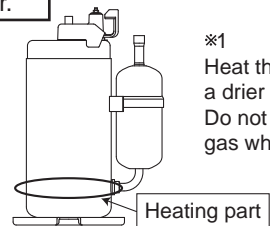
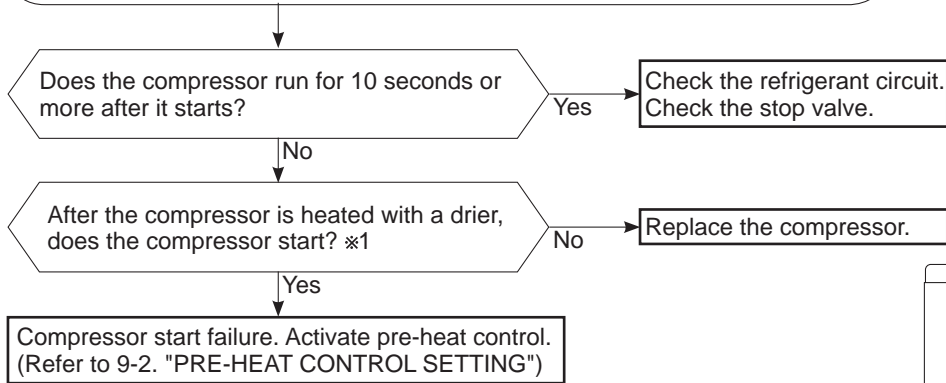

※1 Heat the compressor with a drier for about 20 minutes. Do not recover refrigerant gas while heating.

G Check of outdoor thermistors

Disconnect the connector of thermistor in the outdoor P.C. board (see below table), and measure the resistance of thermistor.

Is the resistance of thermistor normal? (Refer to 10-6.1.)

No → Replace the thermistor except RT64. When RT64 is abnormal, replace the inverter P.C. board.

Yes

Reconnect the connector of thermistor.
Turn ON the power supply and press EMERGENCY OPERATION switch.

Does the unit operate for 10 minutes or more without showing thermistor abnormality?

No → Replace the inverter P.C. board.

Yes

OK. (Cause is poor contact.)

MUZ/MUY-GE09/12/15/18NA

Thermistor	Symbol	Connector, Pin No.	Board
Defrost (MUZ)	RT61	Between CN641 pin1 and pin2	Inverter P.C. board
Discharge temperature	RT62	Between CN641 pin3 and pin4	
Fin temperature	RT64	Between CN642 pin1 and pin2	
Ambient temperature	RT65	Between CN643 pin1 and pin2	
Outdoor heat exchanger temperature	RT68	Between CN644 pin1 and pin3	

MUZ/MUY-GE24NA

Thermistor	Symbol	Connector, Pin No.	Board
Defrost (MUZ)	RT61	Between CN671 pin1 and pin2	Inverter P.C. board
Discharge temperature	RT62	Between CN671 pin3 and pin4	
Fin temperature	RT64	Between CN673 pin1 and pin2	
Ambient temperature	RT65	Between CN672 pin1 and pin2	
Outdoor heat exchanger temperature	RT68	Between CN671 pin5 and pin6	

H Check of R.V. coil

MUZ-GE09/12/15/18/24NA

- ※ First of all, measure the resistance of R.V. coil to check if the coil is defective. Refer to 10-4.
- ※ In case CN721 (MUZ-GE09/12/15/18NA)/CN602 (MUZ-GE24NA) is disconnected or R.V. coil is open, voltage is generated between the terminal pins of the connector although no signal is being transmitted to R.V. coil. Check if CN721 (MUZ-GE09/12/15/18NA)/CN602 (MUZ-GE24NA) is connected.

Unit operates COOL mode even if it is set to HEAT mode.

Disconnect connector between the compressor and the intelligent power module.
Turn ON the power supply and press EMERGENCY OPERATION switch twice (HEAT mode).

Is there 208/230 VAC between CN721 (MUZ-GE09/12/15/18NA)/CN602 (MUZ-GE24NA) ① and ② on the inverter P.C. board 3 minutes after the power supply is turned ON?

No → Replace the inverter P.C. board.

Yes

Replace the 4-way valve.

Unit operates HEAT mode even if it is set to COOL mode.

Disconnect connector between the compressor and the intelligent power module.
Turn ON the power supply and press EMERGENCY OPERATION switch once (COOL mode).

Is there 230 VAC between CN721 (MUZ-GE09/12/15/18NA)/CN602 (MUZ-GE24NA) ① and ② on the inverter P.C. board 3 minutes after the power supply is turned ON?

Yes → Replace the inverter P.C. board.

No

Replace the 4-way valve.

① Check of outdoor fan motor

Disconnect the connectors CN931 and CN932 from the inverter P.C. board. Check the connection between the connector CN931 and CN932.

Is the resistance between each terminal of outdoor fan motor normal?
(Refer to 10-4.)

Yes

No

Disconnect CN932 from the inverter P.C. board, and turn on the power supply.

Rotate the outdoor fan motor manually and measure the voltage of CN931.
Between 1(+) and 5(-)
Between 2(+) and 5(-)
Between 3(+) and 5(-)

Does the voltage between each terminal become 5 and 0 VDC repeatedly?

No

Yes

Does the outdoor fan motor rotate smoothly?

No

Yes

Replace the outdoor fan motor.

Replace the inverter P.C. board.

Ⓜ Check of power supply

MUZ-GE09/12/15/18NA MUY-GE09/12/15/18NA

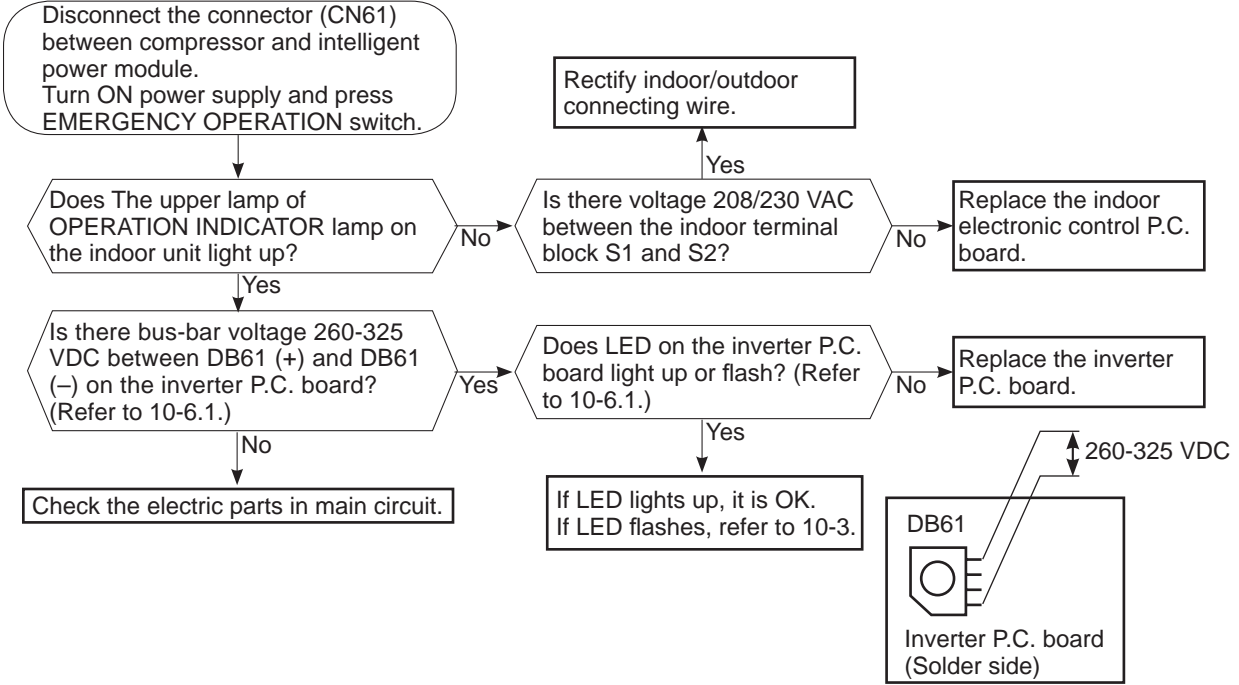

MUZ-GE24NA MUY-GE24NA

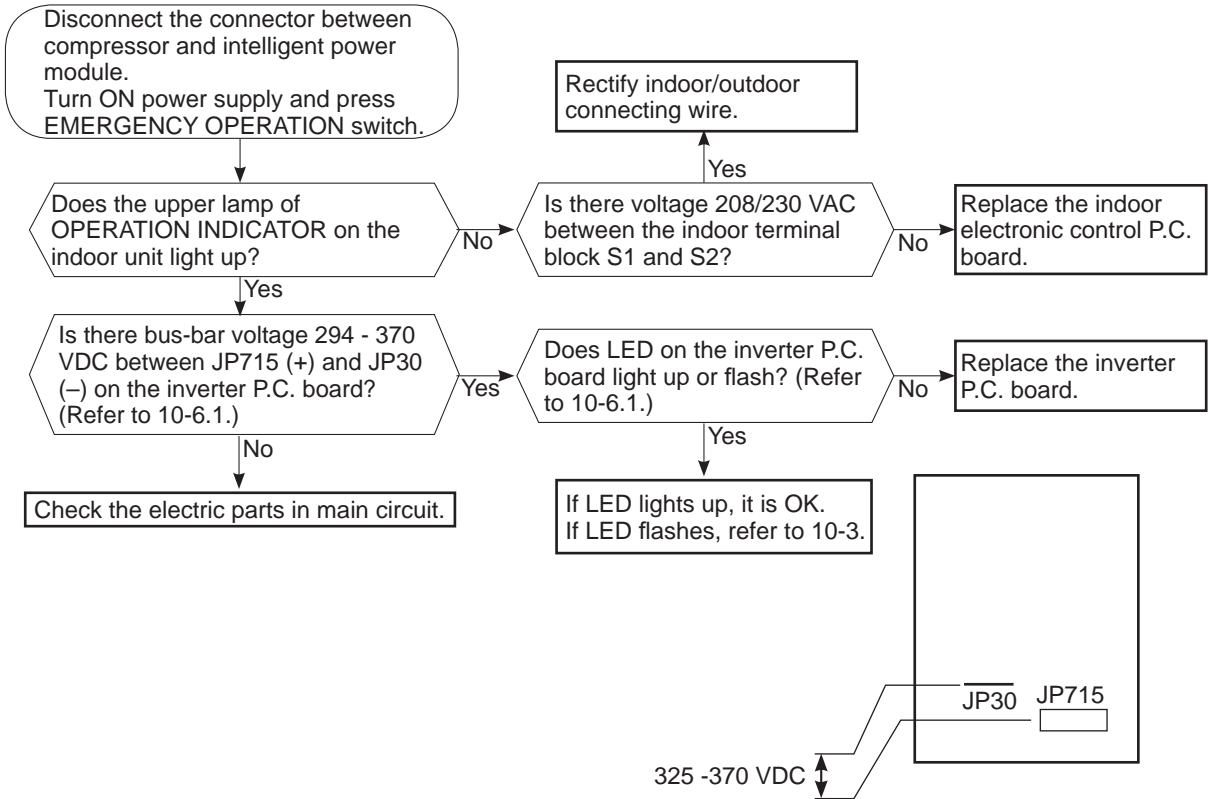

K Check of LEV (Expansion valve)

Turn ON the power supply.

<Preparation of the remote controller>

- ① While pressing both OPERATION SELECT button and TOO COOL button on the remote controller at the same time, press RESET button.
- ② First, release RESET button.
And release the other two buttons after all LCD except the set temperature in operation display section of the remote controller is displayed after 3 seconds.

Press OPERATE/STOP (ON/OFF) button of the remote controller (the set temperature is displayed) with the remote controller headed towards the indoor unit. ※1

Expansion valve operates in full-opening direction.

Do you hear the expansion valve "click, click....." ?
Do you feel the expansion valve vibrate on touching it ?

Yes → OK.

No

Is LEV coil properly fixed to the expansion valve?

No

Properly fix the LEV coil to the expansion valve.

Yes

Does the resistance of LEV coil have the characteristics? (Refer to 10-4.)

Yes

Measure each voltage between connector pins of CN724 on the inverter P.C. board.
1. Pin③(-) — Pin①(+)
2. Pin④(-) — Pin①(+)
3. Pin⑤(-) — Pin①(+)
4. Pin⑥(-) — Pin①(+)
Is there about 3 ~ 5 VAC between each?
NOTE: Measure the voltage by an analog tester.

No → Replace the inverter P.C. board.

No

Replace the LEV coil.

Yes

Replace the expansion valve.

MSZ-GE06/09/12/15/18NA
MSY-GE09/12/15/18NA

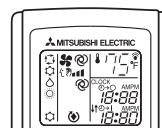
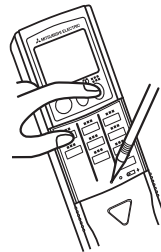

MSZ-GE24NA
MSY-GE24NA

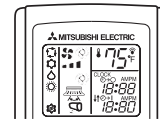
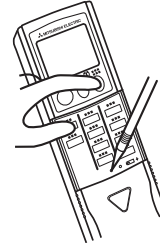

※1. Regardless of normal or abnormal condition, a short beep is emitted once the signal is received.

NOTE: After check of LEV, do the undermentioned operations.

1. Turn OFF the power supply and turn ON it again.
2. Press RESET button on the remote controller.

L Check of inverter P.C. board

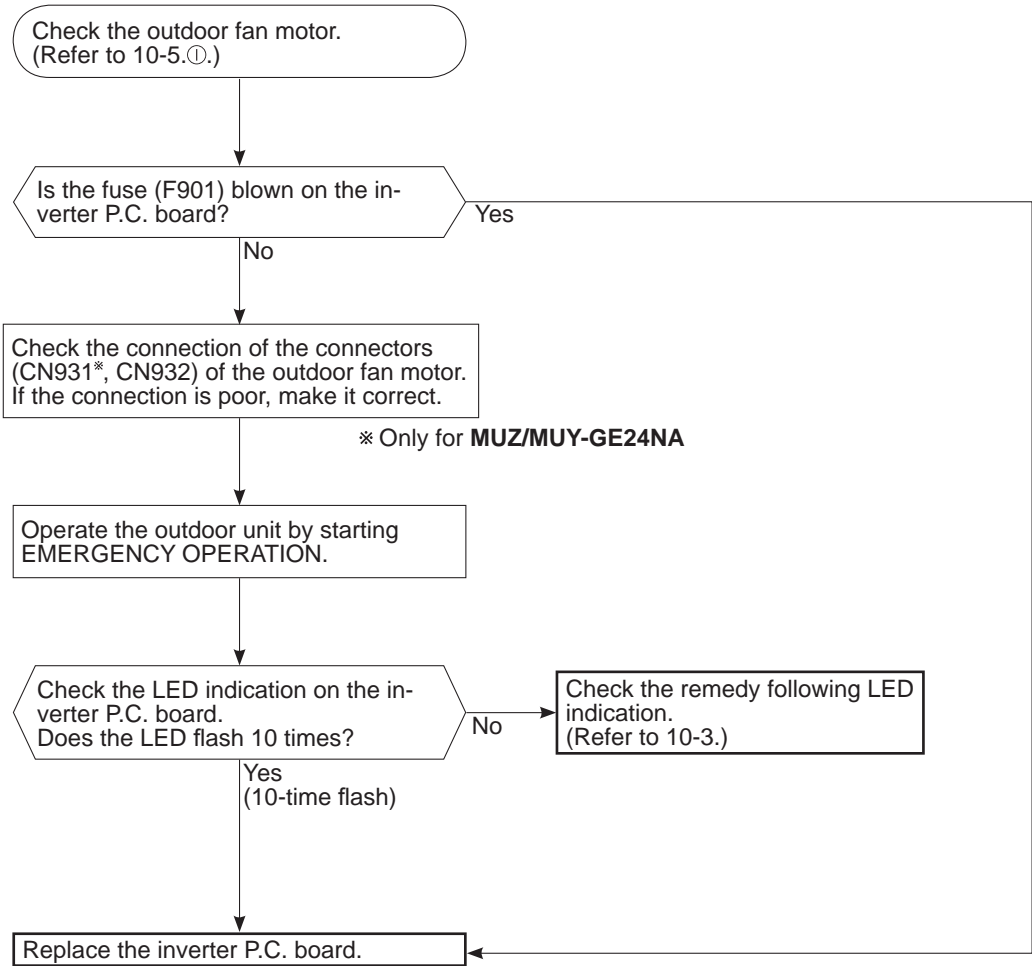

M How to check miswiring and serial signal error

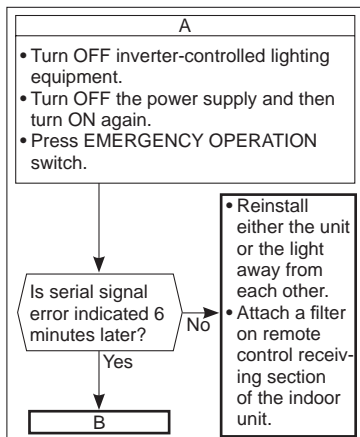
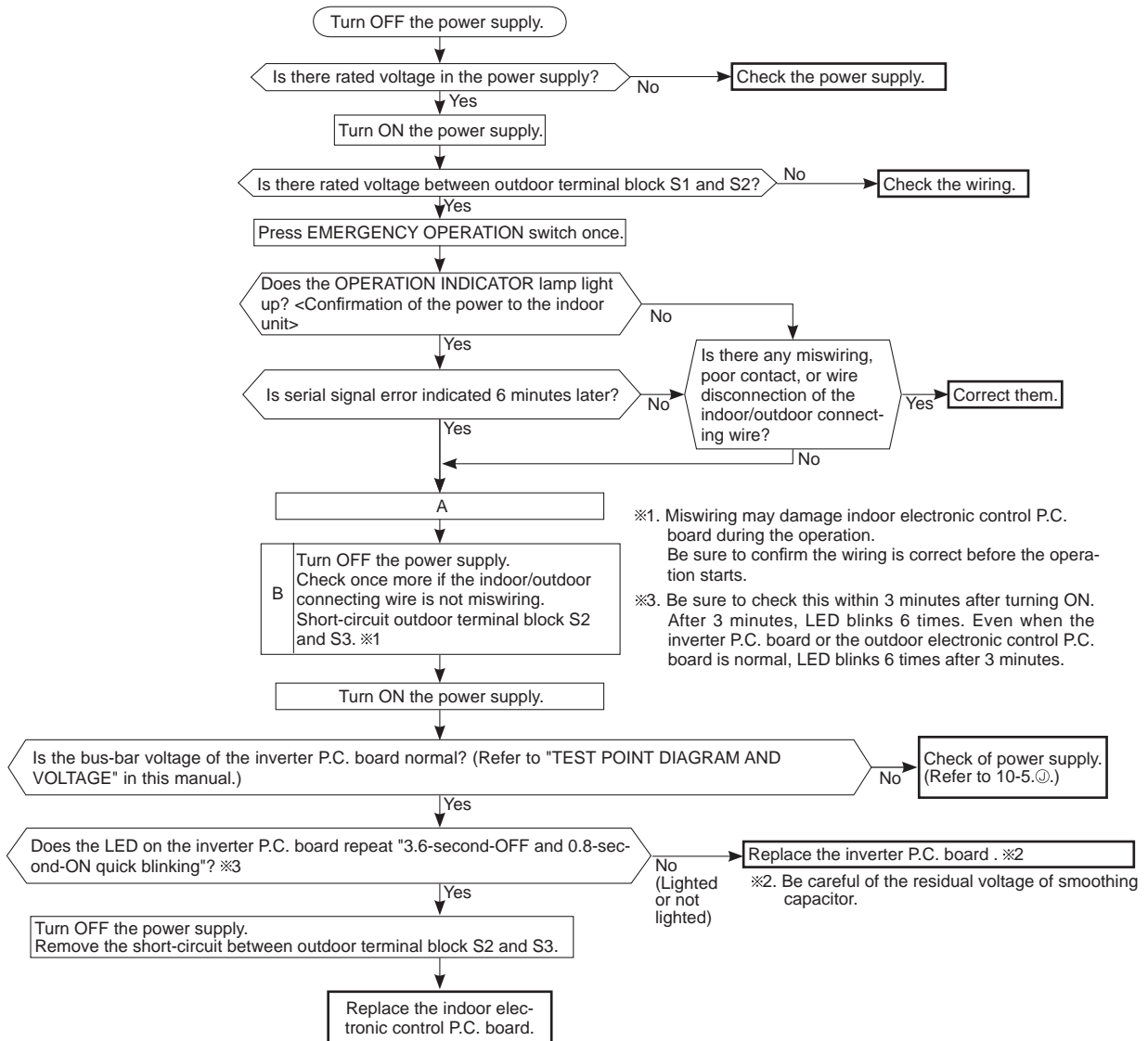

Ⓝ Electromagnetic noise enters into TV sets or radios

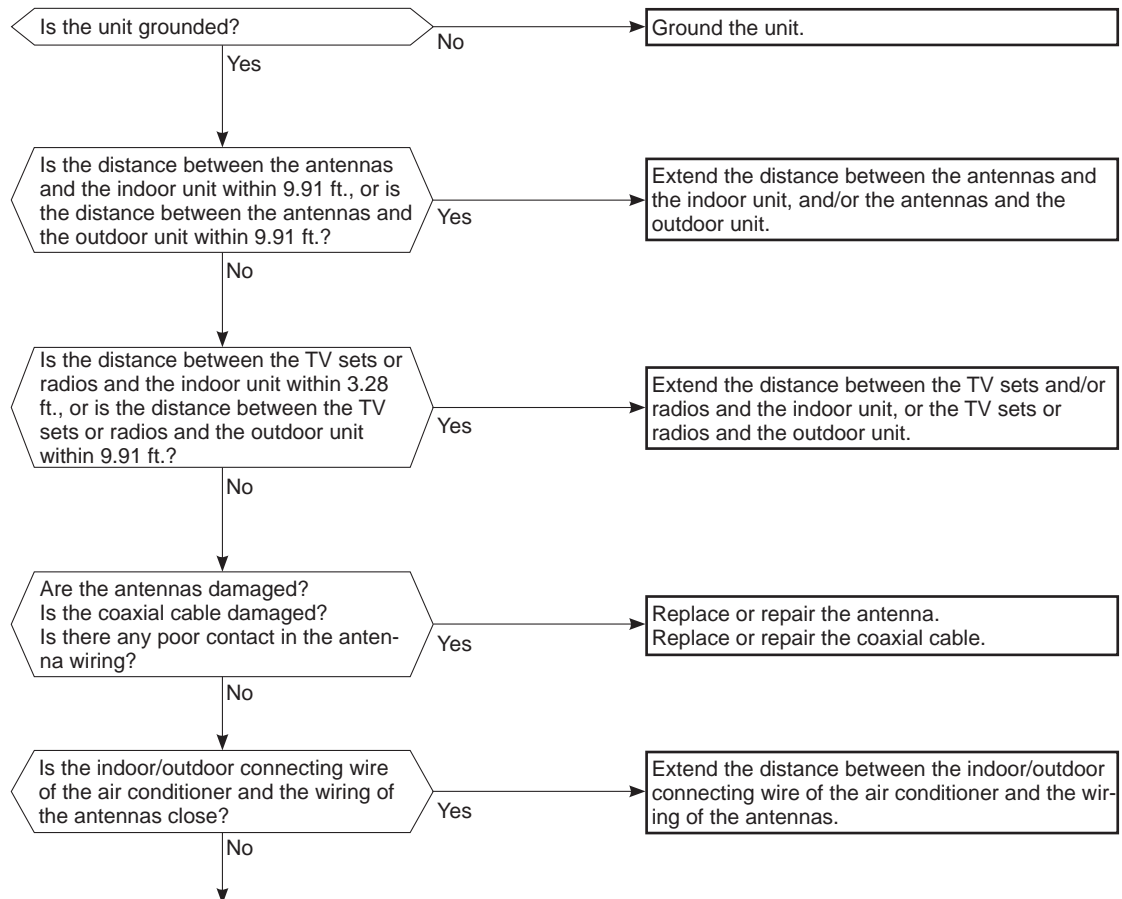

Even if all of the above conditions are fulfilled, the electromagnetic noise may enter, depending on the electric field strength or the installation condition (combination of specific conditions such as antennas or wiring).

Check the followings before asking for service.

1. Devices affected by the electromagnetic noise

TV sets, radios (FM/AM broadcast, shortwave)

2. Channel, frequency, broadcast station affected by the electromagnetic noise

3. Channel, frequency, broadcast station unaffected by the electromagnetic noise

4. Layout of:

indoor/outdoor unit of the air conditioner, indoor/outdoor wiring, grounding wire, antennas, wiring from antennas, receiver

5. Electric field intensity of the broadcast station affected by the electromagnetic noise

6. Presence or absence of amplifier such as booster

7. Operation condition of air conditioner when the electromagnetic noise enters in

1) Turn OFF the power supply once, and then turn ON the power supply. In this situation, check for the electromagnetic noise.

2) Within 3 minutes after turning ON the power supply, press OPERATE/STOP (ON/OFF) button on the remote controller for power ON, and check for the electromagnetic noise.

3) After a short time (3 minutes later after turning ON), the outdoor unit starts running. During operation, check for the electromagnetic noise.

4) Press OPERATE/STOP (ON/OFF) button on the remote controller for power OFF, when the outdoor unit stops but the indoor/outdoor communication still runs on. In this situation, check for the electromagnetic noise.

10-6. TEST POINT DIAGRAM AND VOLTAGE

1. Inverter P.C. board

MUZ-GE09NA MUZ-GE12NA MUZ-GE15NA MUY-GE09NA MUY-GE12NA MUY-GE15NA

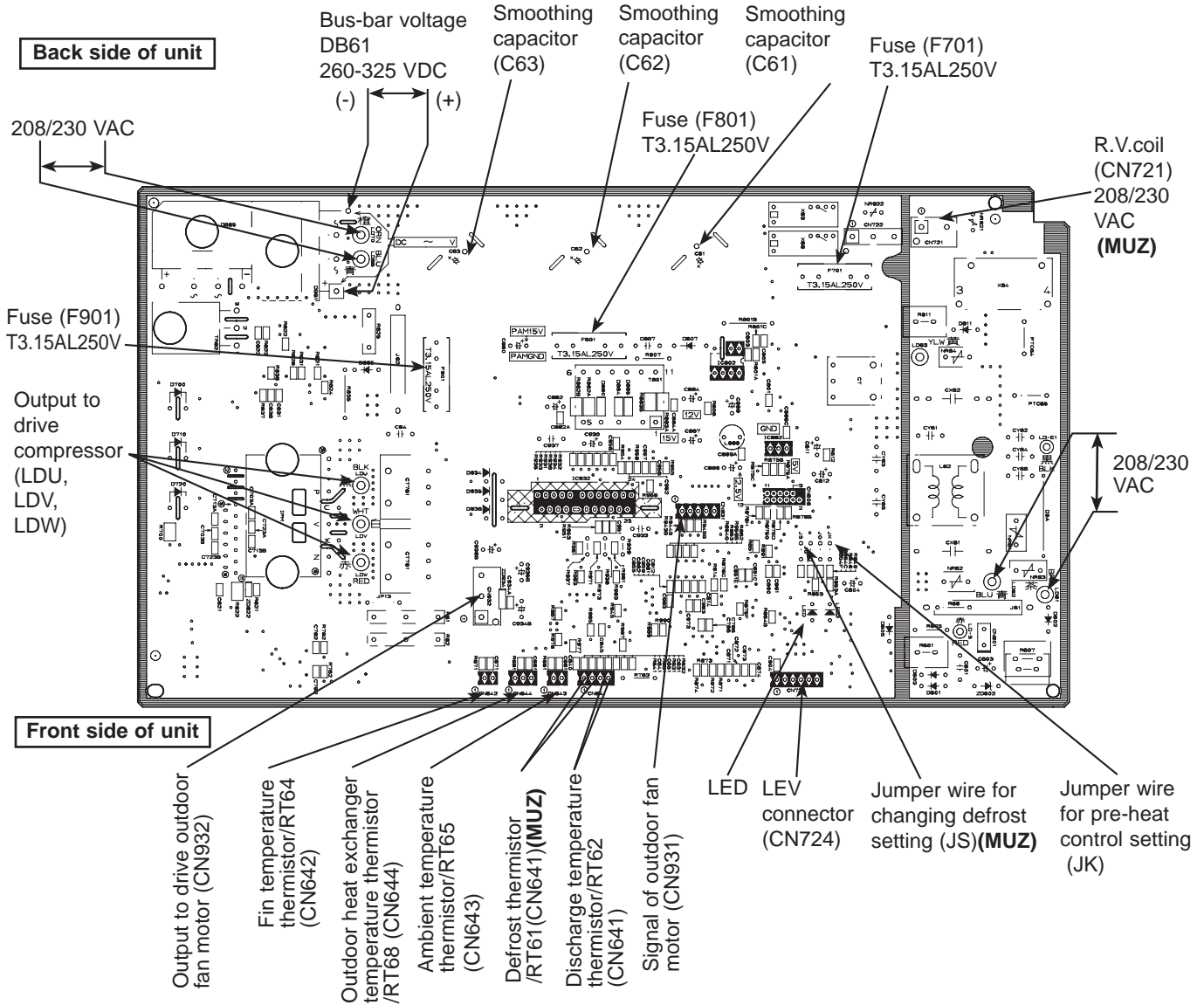

Defrost thermistor (RT61) (MUZ)
Ambient temperature thermistor (RT65)
Outdoor heat exchanger temperature thermistor (RT68)

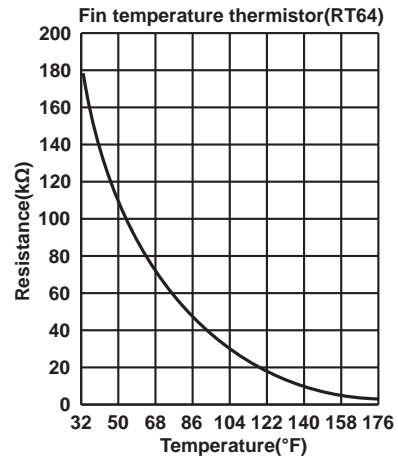
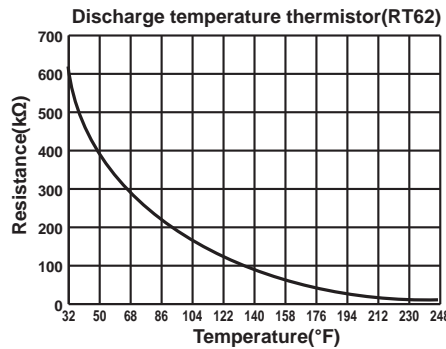
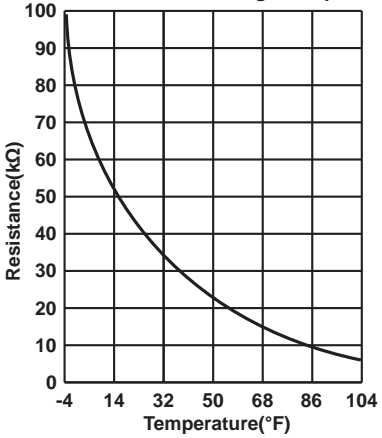

MUZ-GE18NA MUY-GE18NA

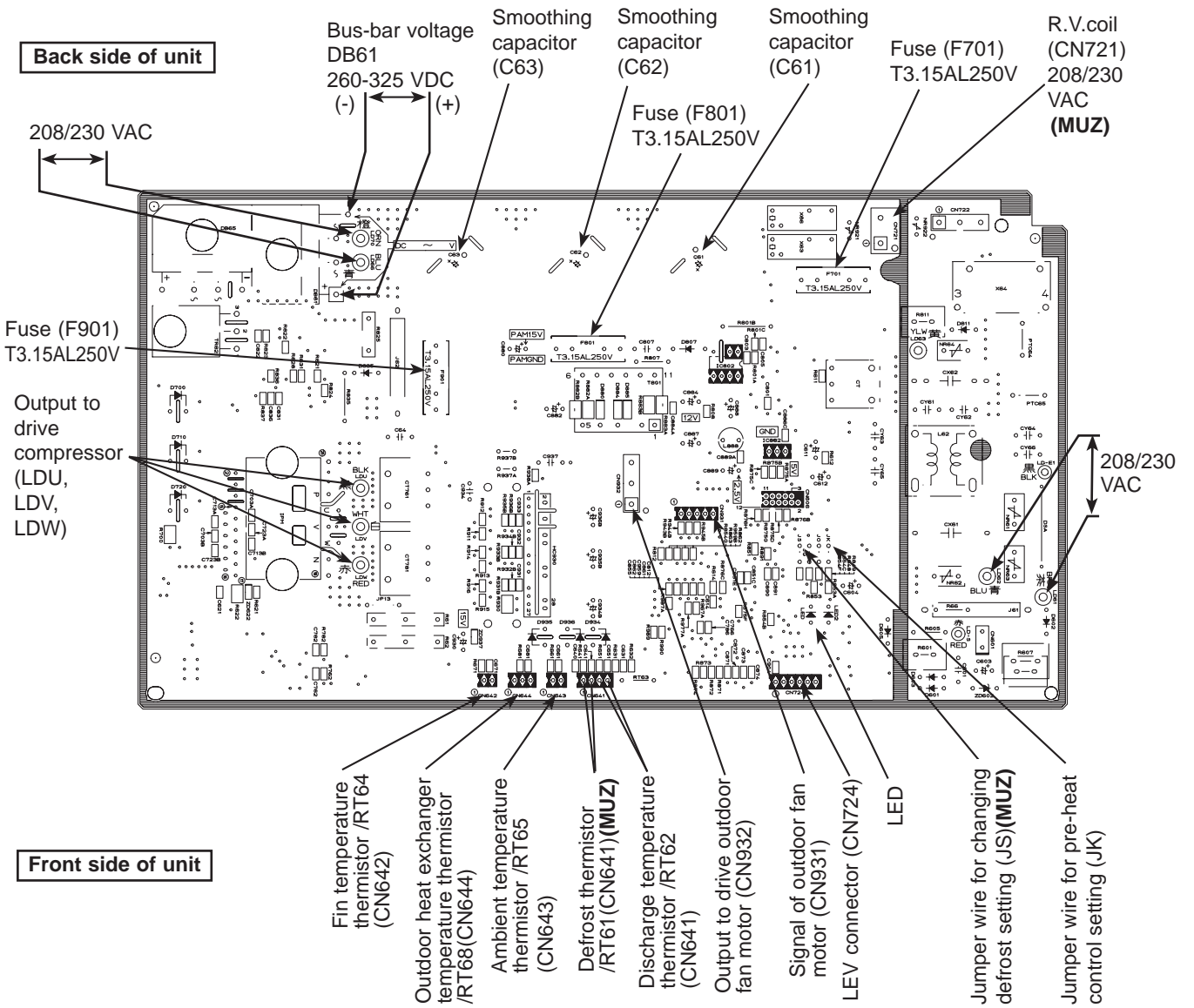

Defrost thermistor (RT61) (MUZ)
Ambient temperature thermistor (RT65)
Outdoor heat exchanger temperature thermistor (RT68)

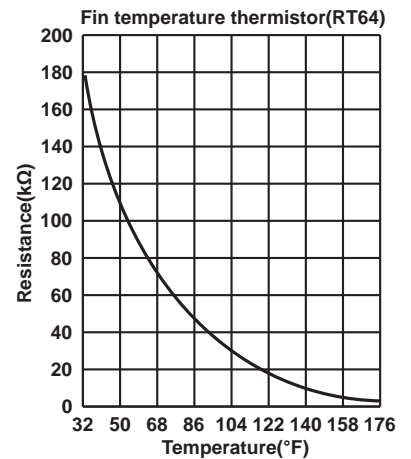
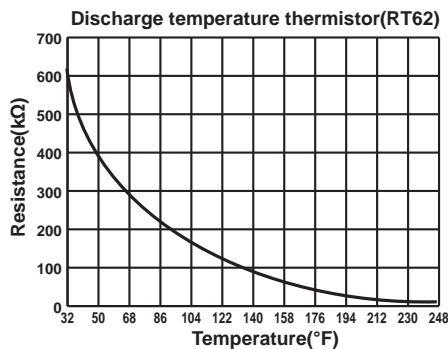
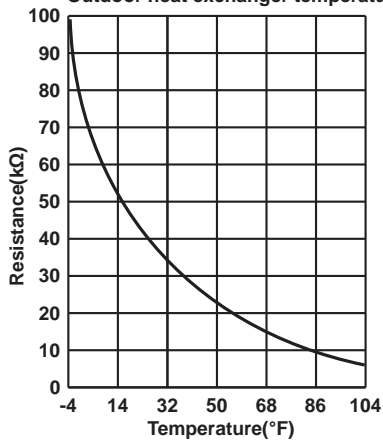

MUZ-GE24NA
MUY-GE24NA

Fuse (F62) T2.0AL250V
 Fuse (F601) T3.15AL250V (MUZ)
 R.V. coil (CN602) 208/230 VAC (MUZ)

Jumper wire for changing defrost setting (JS) (MUZ)

Jumper wire for pre-heat control setting (JK)

Defrost thermistor /RT61 (CN671) (MUZ)

Discharge temperature thermistor/RT62 (CN671)

Outdoor heat exchanger temperature thermistor /RT68 (CN671)

Ambient temperature thermistor/RT65 (CN672)

Fin temperature thermistor/RT64 (CN673)

Signal of outdoor fan motor (CN931)

LED

Output to drive outdoor fan motor (CN932)

Fuse (F901) T3.15AL250V

Fuse (F880) T3.15AL250V

LEV connector (CN724)

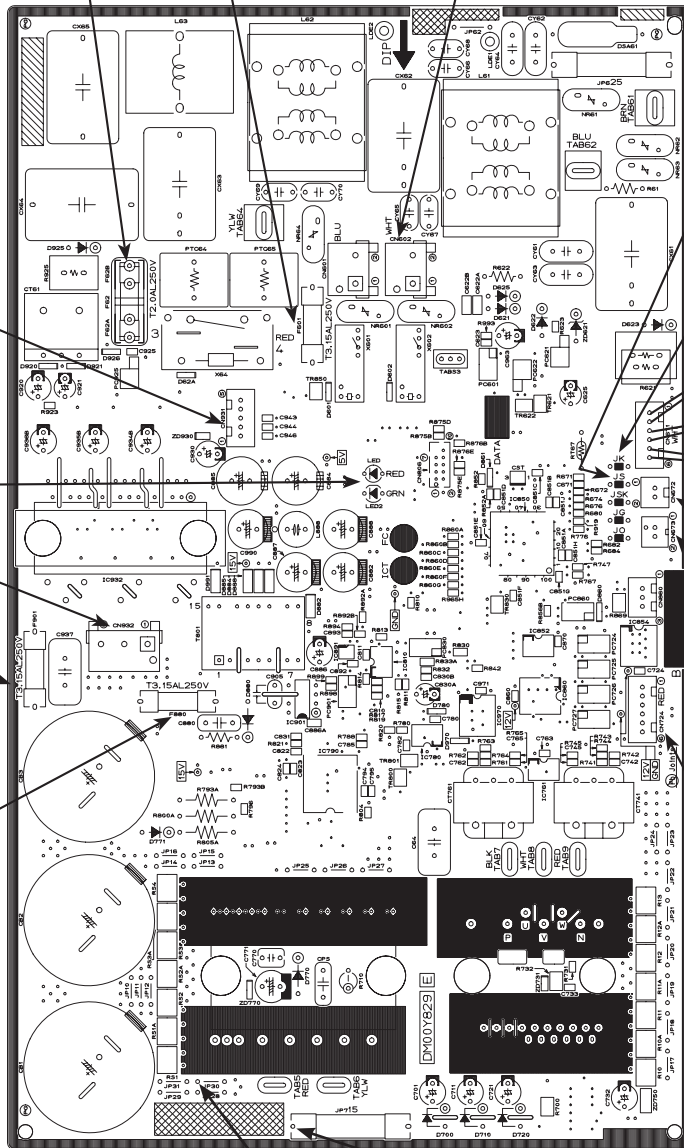

JP715 (+)

Bus-bar voltage
325 - 370 VDC

JP30 (-)

Defrost thermistor (RT61) (MUZ)
 Ambient temperature thermistor (RT65)
 Outdoor heat exchanger temperature thermistor (RT68)

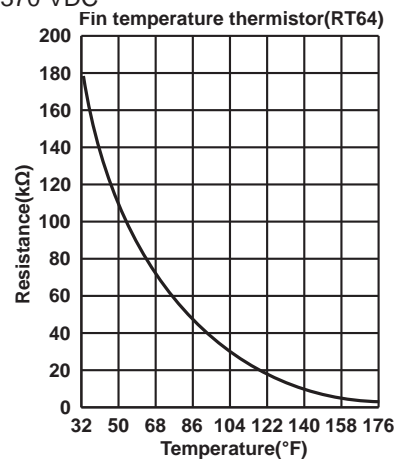
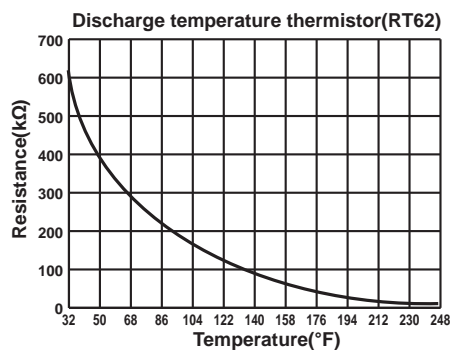
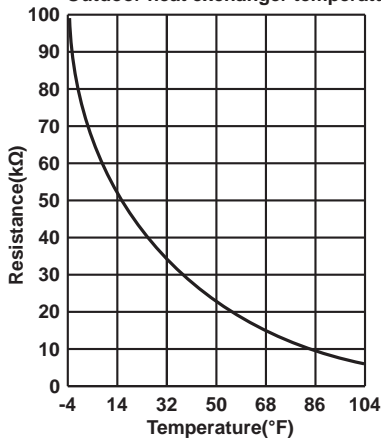

<"Terminal with locking mechanism" Detaching points>

The terminal which has the locking mechanism can be detached as shown below. There are two types (refer to (1) and (2)) of the terminal with locking mechanism. The terminal without locking mechanism can be detached by pulling it out. Check the shape of the terminal before detaching.

(1) Slide the sleeve and check if there is a locking lever or not.

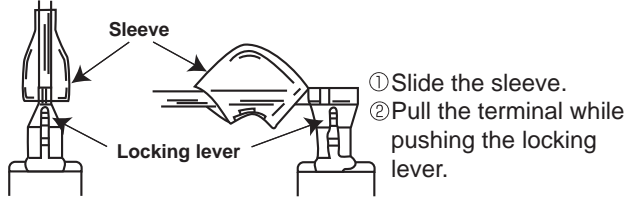

(2) The terminal with this connector has the locking mechanism.

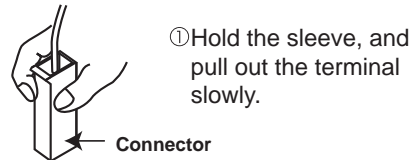

11-1. MUZ-GE09NA MUZ-GE12NA MUZ-GE15NA
MUY-GE09NA MUY-GE12NA MUY-GE15NA

NOTE: Turn OFF power supply before disassembly.

OPERATING PROCEDURE	PHOTOS
<p>1. Removing the cabinet</p> <ol style="list-style-type: none"> (1) Remove the screw fixing the service panel. (2) Pull down the service panel and remove it. (3) Remove the screws fixing the conduit cover. (4) Remove the conduit cover. (5) Disconnect the power supply wire and indoor/outdoor connecting wire. (6) Remove the screws fixing the top panel. (7) Remove the top panel. (8) Remove the screws fixing the cabinet. (9) Remove the cabinet. (10) Remove the screws fixing the back panel. (11) Remove the back panel. <p>Photo 2</p>	<p>Photo 1</p> <p>Photo 3</p>

OPERATING PROCEDURE

2. Removing the inverter assembly, inverter P.C. board

- (1) Remove the cabinet and panels. (Refer to 1.)
- (2) Disconnect the lead wire to the reactor and the following connectors:
 - <Inverter P.C. board>
 - CN721 (R.V. coil) **(MUZ)**
 - CN931, CN932 (Fan motor)
 - CN641 (Defrost thermistor **(MUZ)** and discharge temperature thermistor)
 - CN643 (Ambient temperature thermistor)
 - CN644 (Outdoor heat exchanger temperature thermistor)
 - CN724 (LEV)
- (3) Remove the compressor connector (CN61).
- (4) Remove the screws fixing the heat sink support and the separator.
- (5) Remove the fixing screws of the terminal block support and the back panel.
- (6) Remove the inverter assembly.
- (7) Remove the screw of the ground wire and screw of the terminal block support.
- (8) Remove the heat sink support from the P.C. board support.
- (9) Remove the screw of the inverter P.C. board and remove the inverter P.C. board from the P.C. board support.

PHOTOS

Photo 4

Screws of the heat sink support and the separator

Screws of the terminal block support and the back panel



Photo 5 (Inverter assembly)

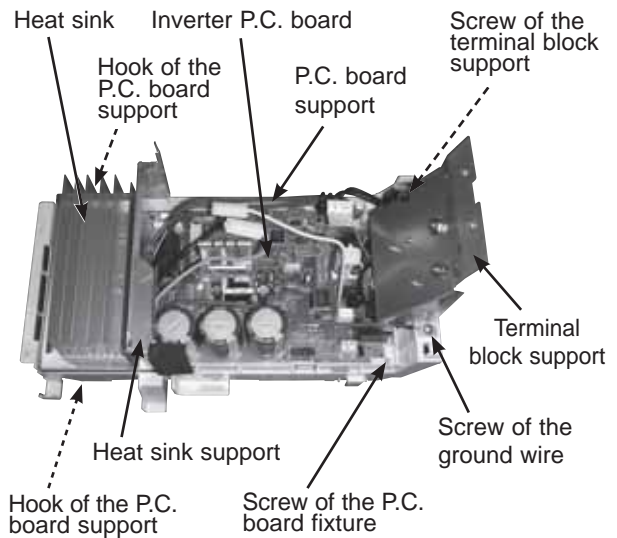

3. Removing R.V. coil (MUZ)

- (1) Remove the cabinet and panels. (Refer to 1.)
- (2) Disconnect the following connectors:
 - <Inverter P.C. board>
 - CN721 (R.V. coil)
- (3) Remove the R.V. coil.

Photo 6

R.V. coil **(MUZ)**



Discharge temperature thermistor



11-2. MUZ-GE18NA MUY-GE18NA

NOTE: Turn OFF power supply before disassembly.

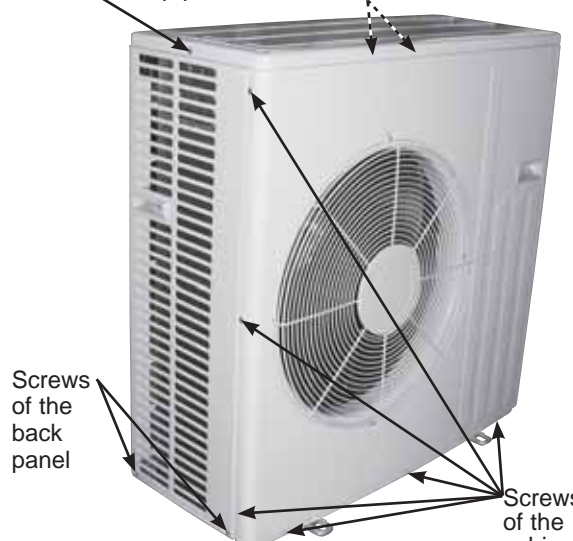
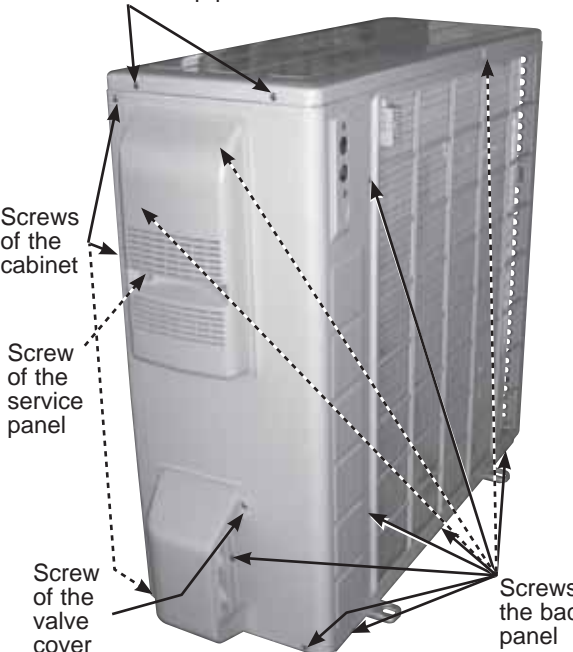
OPERATING PROCEDURE	PHOTOS
<p>1. Removing the cabinet</p> <ol style="list-style-type: none">(1) Remove the screws of the service panel.(2) Remove the screws of the top panel.(3) Remove the screw of the valve cover.(4) Remove the service panel.(5) Remove the top panel.(6) Remove the valve cover.(7) Disconnect the power supply and indoor/outdoor connecting wire.(8) Remove the screws of the cabinet.(9) Remove the cabinet.(10) Remove the screws of the back panel.(11) Remove the back panel.	<p>Photo 1</p> <p>Screw of the top panel Screws of the cabinet</p>  <p>Photo 2</p> <p>Screws of the top panel</p>  <p>Screws of the back panel</p> <p>Screws of the cabinet</p> <p>Screw of the service panel</p> <p>Screw of the valve cover</p> <p>Screws of the back panel</p>

OPERATING PROCEDURE

2. Removing the inverter assembly, inverter P.C. board

- (1) Remove the cabinet and panels. (Refer to 1.)
- (2) Disconnect the lead wire to the reactor and the following connectors:
 - <Inverter P.C. board>
 - CN721 (R.V.coil) **(MUZ)**
 - CN931, CN932 (Fan motor)
 - CN641 (Defrost thermistor **(MUZ)** and discharge temperature thermistor)
 - CN643 (Ambient temperature thermistor)
 - CN644 (Outdoor heat exchanger temperature thermistor)
 - CN724 (LEV)
- (3) Remove the compressor connector (CN61).
- (4) Remove the screws fixing the heat sink support and the separator.
- (5) Remove the fixing screws of the terminal block support and the back panel.
- (6) Remove the inverter assembly.
- (7) Remove the screw of the ground wire and screw of the terminal block support.
- (8) Remove the heat sink support from the P.C. board support.
- (9) Remove the screw of the inverter P.C. board and remove the inverter P.C. board from the P.C. board support.

3. Removing R.V. coil

- (1) Remove the cabinet and panels. (Refer to 1.)
- (2) Disconnect the following connectors:
 - <Inverter P.C. board>
 - CN721 (R.V. coil) **(MUZ)**
- (3) Remove the R.V. coil.

PHOTOS

Photo 3

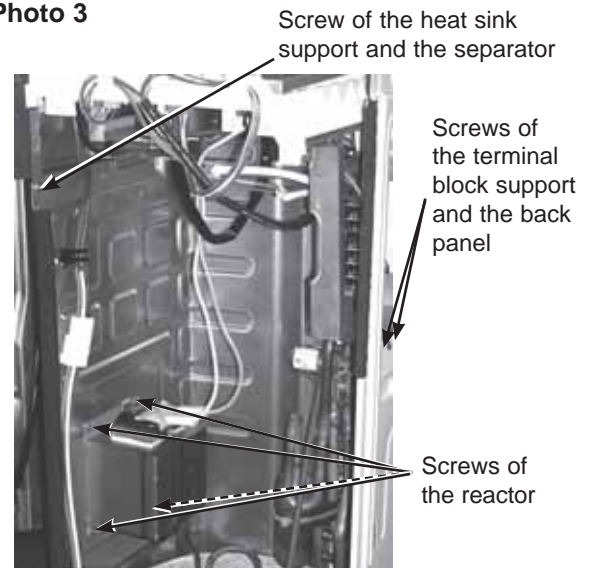

Photo 4 (Inverter assembly)

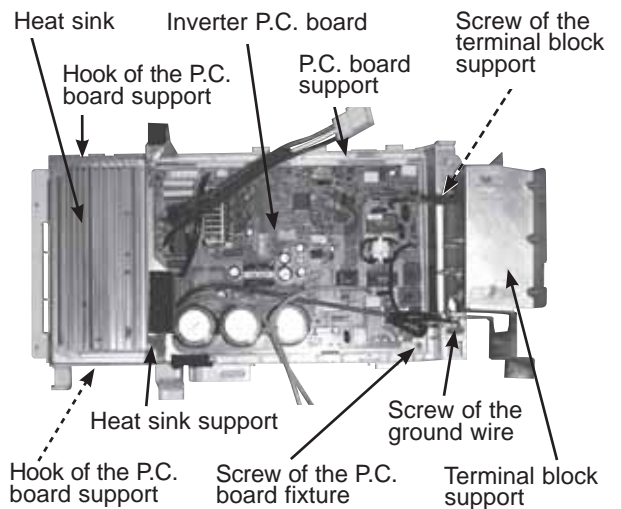
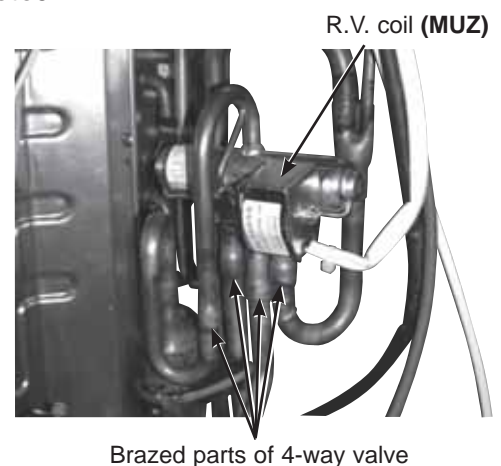

Photo5



OPERATING PROCEDURE

4. Removing the discharge temperature thermistor, defrost thermistor, outdoor heat exchanger temperature thermistor and ambient temperature thermistor

- (1) Remove the cabinet and panels. (Refer to 1.)
- (2) Disconnect the lead wire to the reactor and the following connectors:
<Inverter P.C. board>
CN641 (Defrost thermistor **(MUZ)** and discharge temperature thermistor)
CN643 (Ambient temperature thermistor)
CN644 (Outdoor heat exchanger temperature thermistor)
- (3) Pull out the discharge temperature thermistor from its holder. (Photo 8)
- (4) Pull out the defrost thermistor from its holder.
- (5) Pull out the outdoor heat exchanger temperature thermistor from its holder.
- (6) Pull out the ambient temperature thermistor from its holder.

5. Removing outdoor fan motor

- (1) Remove the top panel, cabinet and service panel. (Refer to 1.)
- (2) Disconnect the following connectors:
<Inverter P.C. board>
CN931 and CN932 (Fan motor)
- (3) Remove the propeller.
- (4) Remove the screws fixing the fan motor.
- (5) Remove the fan motor.

6. Removing the compressor and 4-way valve

- (1) Remove the top panel, cabinet and service panel. (Refer to 1.)
- (2) Remove the back panel. (Refer to 1.)
- (3) Remove the inverter assembly. (Refer to 2.)
- (4) Recover gas from the refrigerant circuit.
NOTE: Recover gas from the pipes until the pressure gauge shows 0 PSIG.
- (5) Detach the brazed part of the suction and the discharge pipes connected with compressor.
- (6) Remove the compressor nuts.
- (7) Remove the compressor.
- (8) Detach the brazed parts of 4-way valve and pipes. (Photo 5)

PHOTOS

Photo 6



Photo 7

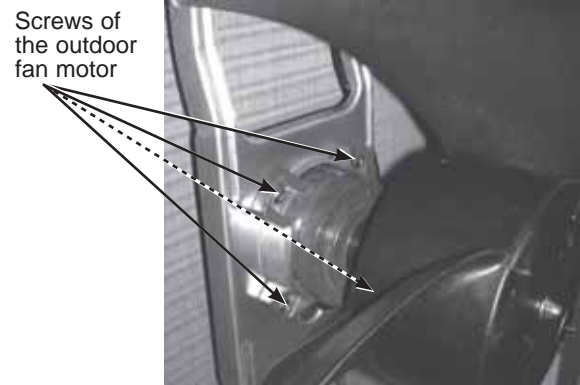
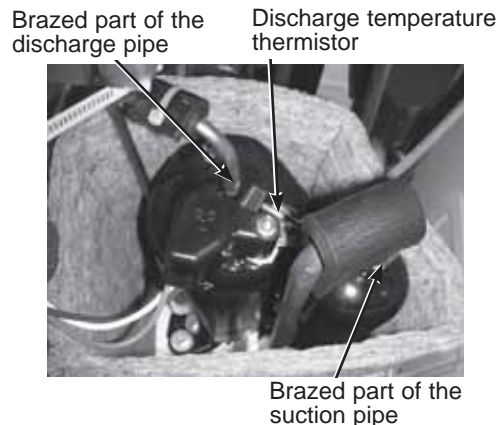
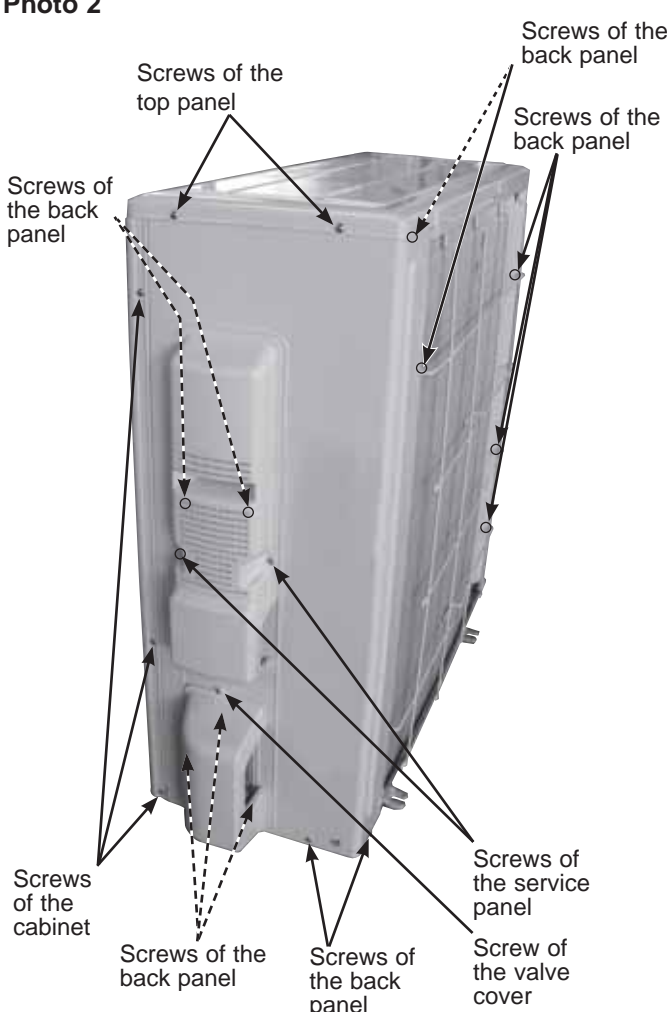
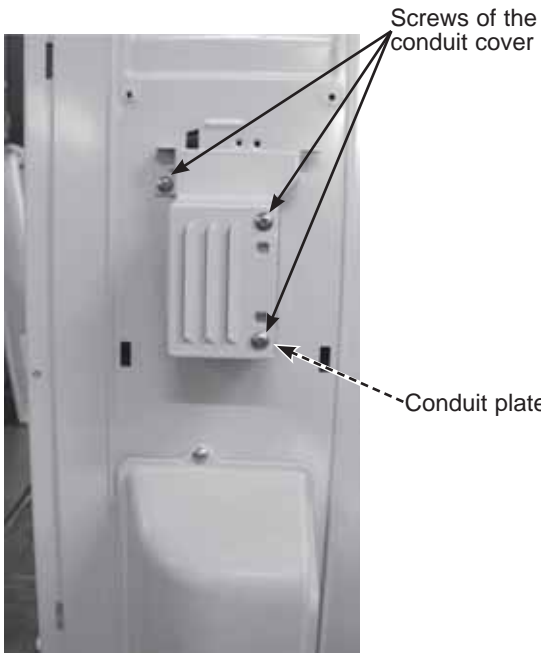
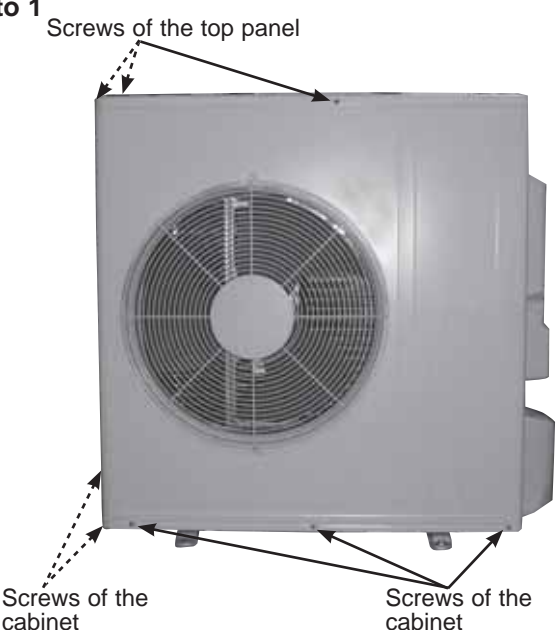
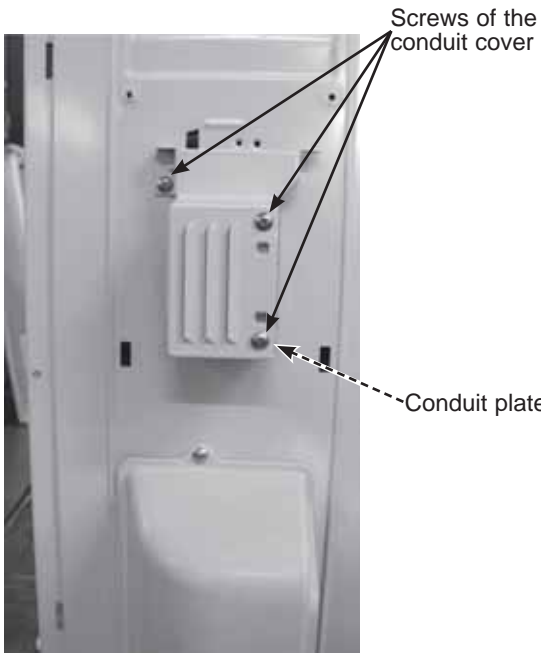

Photo 8



11-3. MUZ-GE24NA MUY-GE24NA

NOTE: Turn OFF power supply before disassembly.

OPERATING PROCEDURE	PHOTOS
<p>1. Removing the cabinet</p> <ol style="list-style-type: none"> (1) Remove the screws of the service panel. (2) Remove the screws of the top panel. (3) Remove the screw of the valve cover. (4) Remove the service panel. (5) Remove the screws fixing the conduit cover. (6) Remove the conduit cover. (7) Remove the top panel. (8) Remove the valve cover. (9) Disconnect the power supply and indoor/outdoor connecting wire. (10) Remove the screws of the cabinet. (11) Remove the cabinet. (12) Remove the screws of the back panel. (13) Remove the back panel. <p>Photo 2</p>  <p>Photo 3</p> 	<p>Photo 1</p>  <p>Photo 3</p> 

OPERATING PROCEDURE

2. Removing the inverter assembly, inverter P.C. board

- (1) Remove the cabinet and panels. (Refer to 1.)
- (2) Disconnect the lead wire to the reactor and the following connectors:
<Inverter P.C. board>
CN602 (R.V. coil)
CN931, CN932 (Fan motor)
CN671 (Defrost thermistor, discharge temperature thermistor and outdoor heat exchanger temperature thermistor)
CN672 (Ambient temperature thermistor)
CN724 (LEV)
- (3) Remove the compressor connector.
- (4) Remove the screws fixing the relay panel.
- (5) Remove the relay panel.
- (6) Remove the ground wires and the lead wires of the inverter P.C. board.
- (7) Remove the screw of the PB support.
- (8) Remove the inverter P.C. board from the relay panel.

PHOTOS

Photo 4

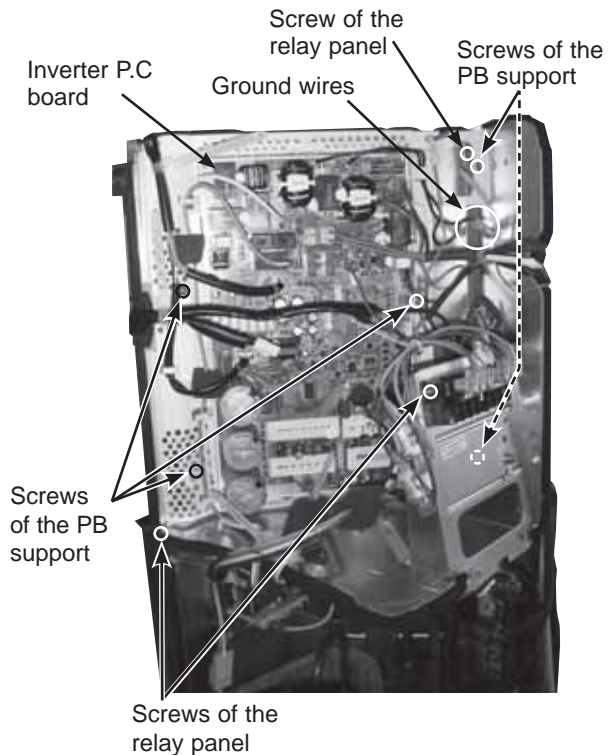

3. Removing R.V. coil

- (1) Remove the cabinet and panels. (Refer to 1.)
- (2) Disconnect the following connector:
<Inverter P.C. board>
CN602 (R.V. coil) **(MUZ)**
- (3) Remove the R.V. coil.

Photo 5

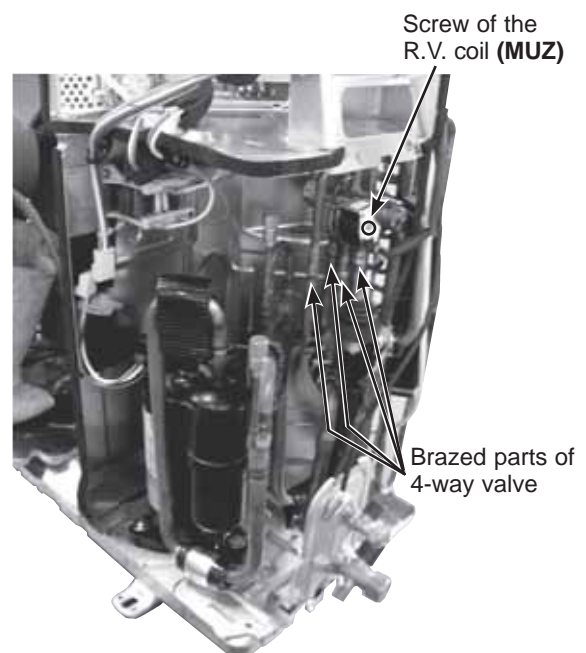



OPERATING PROCEDURE

4. Removing the discharge temperature thermistor, defrost thermistor, outdoor heat exchanger temperature thermistor and ambient temperature thermistor

- (1) Remove the cabinet and panels. (Refer to 1.)
- (2) Disconnect the lead wire to the reactor and the following connectors:
<Inverter P.C. board>
CN671 (Defrost thermistor (MUZ), discharge temperature thermistor and outdoor heat exchanger temperature thermistor)
CN672 (Ambient temperature thermistor)
- (3) Pull out the discharge temperature thermistor from its holder. (Photo 8)
- (4) Pull out the defrost thermistor from its holder.
- (5) Pull out the outdoor heat exchanger temperature thermistor from its holder.
- (6) Pull out the ambient temperature thermistor from its holder.

5. Removing outdoor fan motor

- (1) Remove the top panel, cabinet and service panel. (Refer to 1.)
- (2) Disconnect the following connectors:
<Inverter P.C. board>
CN931 and CN932 (Fan motor)
- (3) Remove the propeller.
- (4) Remove the screws fixing the fan motor.
- (5) Remove the fan motor.

6. Removing the compressor and 4-way valve

- (1) Remove the top panel, cabinet and service panel. (Refer to 1.)
- (2) Remove the back panel. (Refer to 1.)
- (3) Remove the inverter assembly. (Refer to 2.)
- (4) Recover gas from the refrigerant circuit.

NOTE: Recover gas from the pipes until the pressure gauge shows 0 kg/cm² (0 MPa).

- (5) Detach the brazed part of the suction and the discharge pipes connected with compressor.
- (6) Remove the compressor nuts.
- (7) Remove the compressor.
- (8) Detach the brazed parts of 4-way valve and pipes. (Photo 5)

PHOTOS

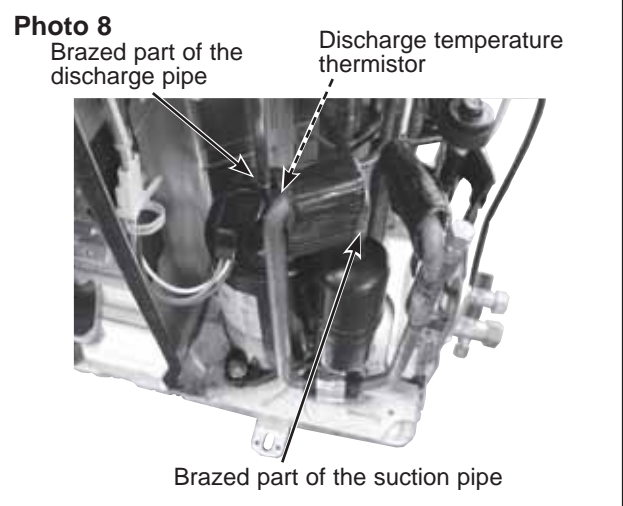
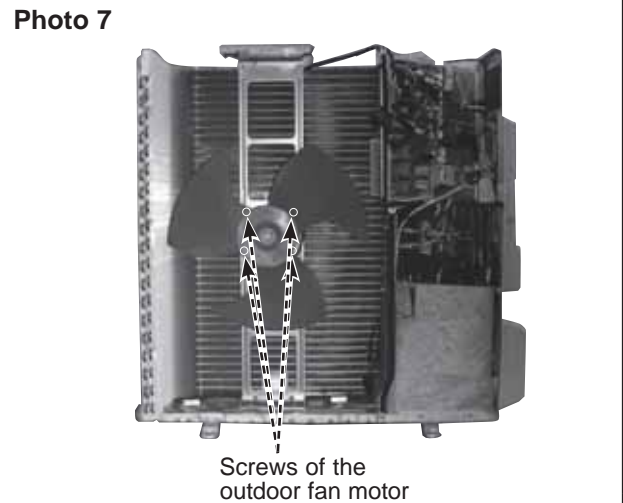
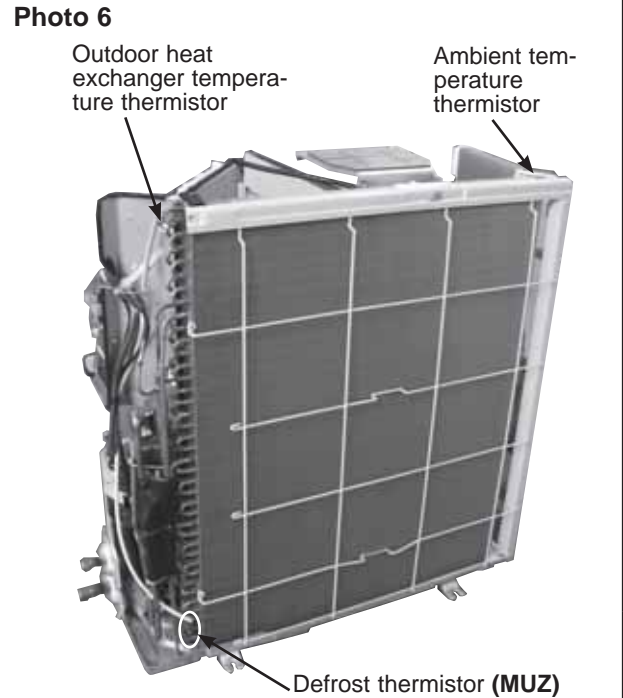

Mr. SLIM™

 **MITSUBISHI ELECTRIC CORPORATION**
HEAD OFFICE: TOKYO BLDG., 2-7-3, MARUNOUCHI, CHIYODA-KU, TOKYO 100-8310, JAPAN

© Copyright 2009 MITSUBISHI ELECTRIC CO.,LTD
Distributed in Dec. 2010. No. OBH 549 REVISED EDITION-B
Distributed in Sep. 2010. No. OBH 549 REVISED EDITION-A 5
Distributed in Jul. 2009. No. OBH 549 5
Made in Japan

New publication, effective Dec. 2010
Specifications subject to change without notice.