

Location:



MIFAB

MI-GARD®

FLOOR DRAIN TRAP SEAL

Specification: MIFAB MI-GARD® Series inline floor drain trap seal with UV resistant ABS plastic frame, silicon rubber sealing flapper and four flexible sealing ribs. Specify connection size (2", 3", 3 1/2" or 4").

Function: Used in the outlet connections of floor drain bodies, or the inside of floor drain strainers to seal the opening to prevent odors, sewer gases, and insects from entering up through the floor drain grate. The MI-GARD®s four flexible silicone sealing ribs ensure easy installation into openings that have variations in size. The MI-GARD® will open to allow drainage and close when there is no water flow. The MI-GARD® can be used in either new construction or retro-fit applications where trap primers were never installed.

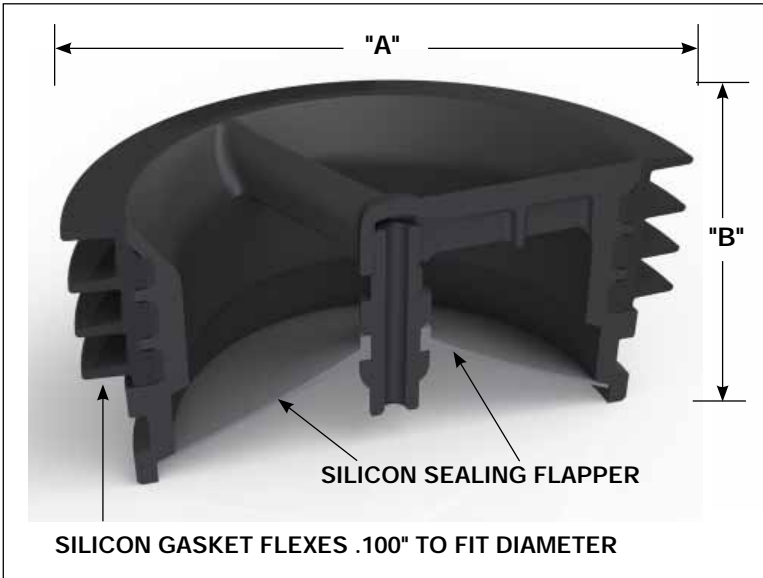

MI-GARD-4



MI-GARD-35

MI-GARD-2

MODEL NUMBER	"A" (PIPE SIZE)	"B" (HEIGHT)
MI-GARD-2	2" (51)	2" (51)
MI-GARD-3	3" (76)	2" (51)
MI-GARD-35	3 1/2" (89)	2" (51)
MI-GARD-4	4" (102)	2" (51)

U.S. Patent #7,900,288

MI-GARD® prevents the following from entering through the top of floor drains:

- Odors and sewer gases
- Insects



BOTTOM OF BODY



TOP OF STRAINER

Job Name:

Section No:

Schedule No:

Page No:

Contract:

Purchase Order No:

MIFAB reserves the right to make changes in material and design without formal notice or obligation.

USA: 1-800-465-2736 www.mifab.com CAN: 1-800-387-3880