

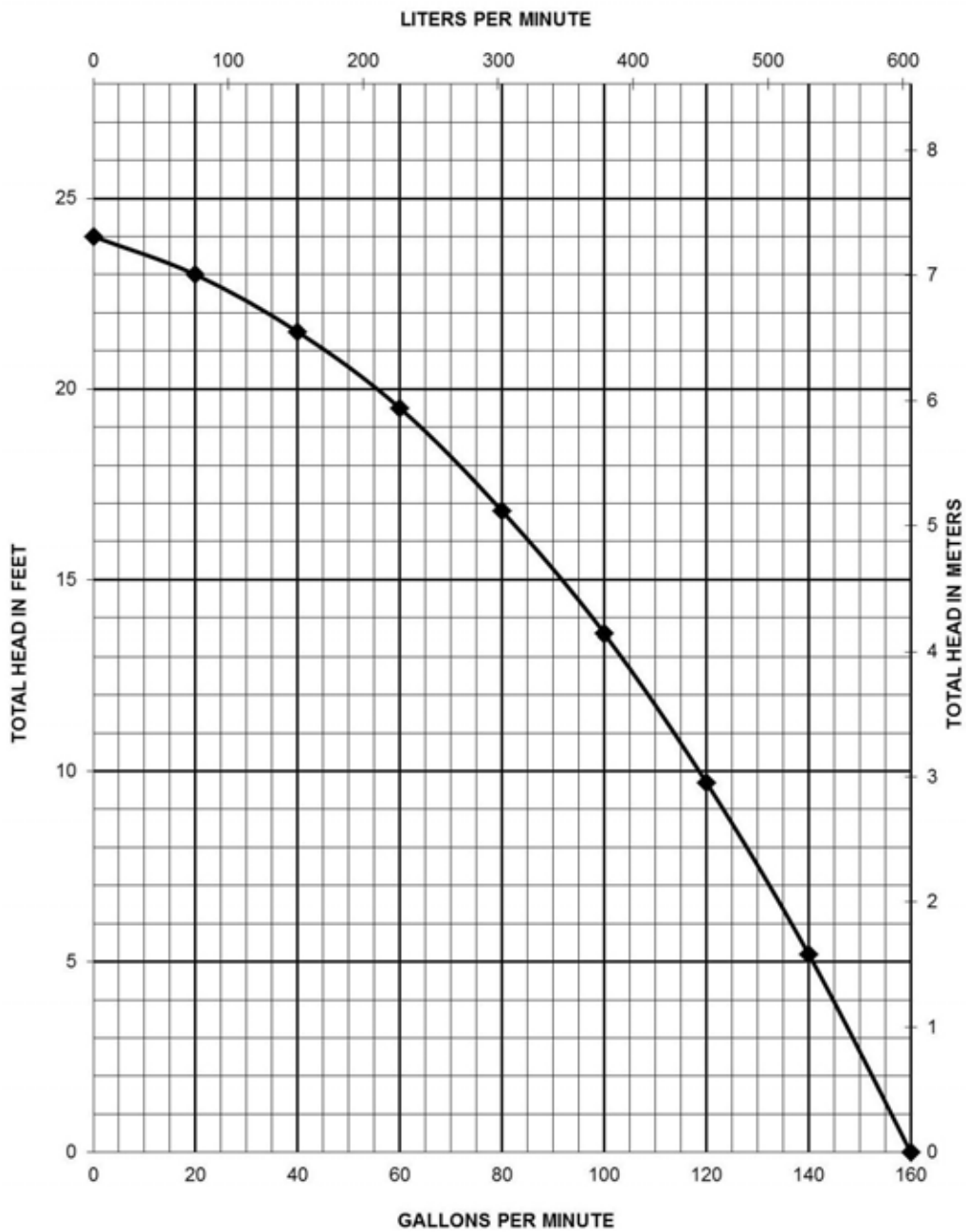

Pump Specifications

LE50 Series 1/2 HP Submersible Sewage Pump

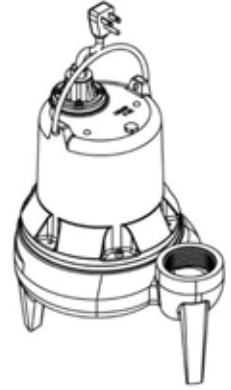

LE50-Series Dimensional Data

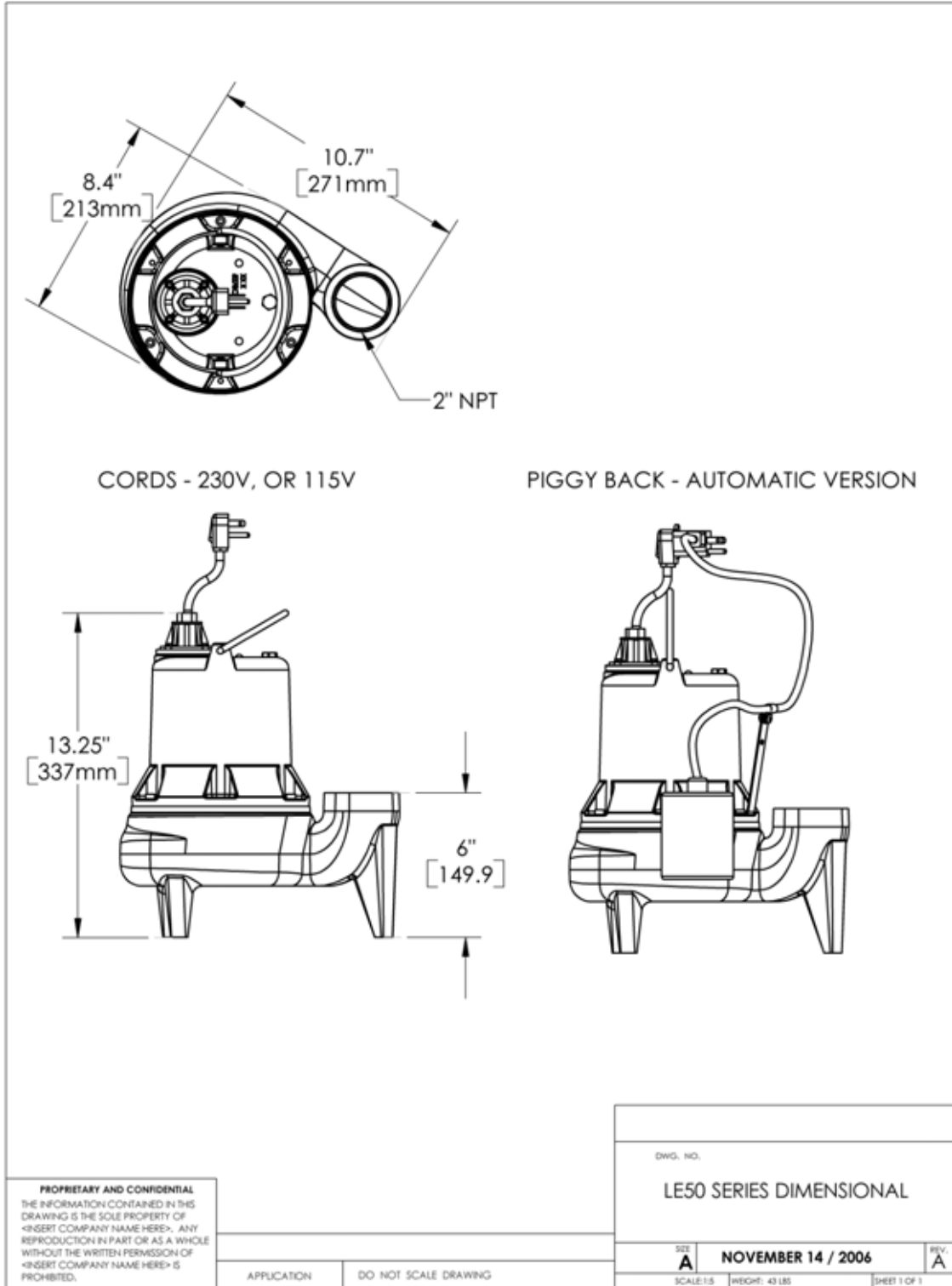

LE50-Series Electrical Data

MODEL	HP	VOLTAGE	PHASE	SF	FULL LOAD AMPS	LOCKED ROTOR AMPS	THERMAL OVERLOAD TEMP	STATOR WINDING CLASS	CORD LENGTH FT	DISCHARGE	AUTOMATIC
LE51A	1/2	115	1	1.00	12	22.5	105°C 221°F	B	10	2"	YES
LE51A-2	1/2	115	1	1.00	12	22.5	105°C 221°F	B	25	2"	YES
LE51M	1/2	115	1	1.00	12	22.5	105°C 221°F	B	10	2"	NO
LE51M-2	1/2	115	1	1.00	12	22.5	105°C 221°F	B	25	2"	NO
LE52A	1/2	208-230	1	1.00	6.8	12	105°C 221°F	B	10	2"	YES
LE52A-2	1/2	208-230	1	1.00	6.8	12	105°C 221°F	B	25	2"	YES
LE52M	1/2	208-230	1	1.00	6.8	12	105°C 221°F	B	10	2"	NO
LE52M-2	1/2	208-230	1	1.00	6.8	12	105°C 221°F	B	25	2"	NO

LE50-Series Technical Data

IMPELLER	2 VANE ENGINEERED THERMOPLASTIC ELASTOMER 2" SOLIDS HANDLING
SOLIDS HANDLING SIZE	2"
PAINT	POWDER COAT
MAX LIQUID TEMP	60°C 140°F
MAX STATOR TEMP	130°C 266°F
THERMAL OVERLOAD	105°C 221°F
POWER CORD TYPE	SJTW
MOTOR HOUSING	CLASS 25 CAST IRON
VOLUTE	CLASS 25 CAST IRON
SHAFT	STAINLESS
HARDWARE	STAINLESS
ORINGS	BUNA N
MECHANICAL SEAL	UNITIZED CERAMIC CARBON
WEIGHT	43 LBS

LE50-Series Specifications

1.01 GENERAL:

The contractor shall provide labor, material, equipment, and incidentals required to provide _____(QTY) centrifugal pumps as specified herein. The pump models covered in this specification are Series LE50 single phase pumps. The pump furnished for this application shall be model _____as manufactured by Liberty pumps.

2.01 OPERATING CONDITIONS:

Each submersible pump shall be rated at 1/2 hp _____volts, single phase, 60 Hz. 1725 RPM. The unit shall produce _____G.P.M. at _____ feet of total dynamic head.

The submersible pump shall be capable of handling residential sewage with 2" solid handling capability. The submersible pump shall have a shut-off head of 24 feet and a maximum flow of 141 GPM @ 5 feet of total dynamic head.

The pump shall be controlled with:

_____A piggy back style on/off float switch.

_____A NEMA 4X outdoor simplex control panel with three float switches and a high water alarm.

_____A NEMA 1 indoor simplex control panel with three float switches and a high water alarm.

_____A NEMA 4X outdoor duplex control panel with three float switches and a high water alarm.

_____A NEMA 1 indoor duplex control panel with three float switches and a high water alarm.

_____A NEMA 4X outdoor duplex control panel with four float switches and a high water alarm.

_____A NEMA 1 indoor duplex control panel with four float switches and a high water alarm.

3.01 CONSTRUCTION:



Each centrifugal sewage pump shall be equal to the c^{us} certified Series LE50 SERIES pumps as manufactured by Liberty Pumps, Bergen NY. The castings shall be constructed of class 25 cast iron. The motor housing shall be oil filled to dissipate heat. Air filled motors shall not be considered equal since they do not properly dissipate heat from the motor. All mating parts shall be machined and sealed with a Buna-N o-ring. All fasteners exposed to the liquid shall be stainless steel. The motor shall be protected on the top side with sealed cord entry plate with molded pins to conduct electricity eliminating the ability of water to enter internally through the cord. The motor shall be protected on the lower side with a unitized ceramic/carbon seal with stainless steel housings and spring. The pump shall be furnished with stainless steel handle.

4.01 ELECTRICAL POWER CORD

The submersible pump shall be supplied with 10 or 25 feet of multiconductor power cord. It shall be cord type SJTW, capable of continued exposure to the pumped liquid. The power cord shall be sized for the rated full load amps of the pump in accordance with the National Electric Code. The power cable shall not enter the motor housing directly but will conduct electricity to the motor by means of a water tight compression fitting cord plate assembly, with molded pins to conduct electricity. This will eliminate the ability of water to enter internally through the cord, by means of a damaged or wicking cord.

5.01 MOTORS

Single phase motors shall be oil filled, permanent split capacitor, class B insulated NEMA B design, rated for continuous duty. At maximum load the winding temperature shall not exceed 130 degrees C unsubmerged. Since air filled motors are not capable of dissipating heat they shall not be considered equal. The pump motor shall have an integral thermal overload switch in the windings for protecting the motor. The capacitor circuit shall be mounted internally in the pump.

6.01 BEARINGS AND SHAFT

An upper and lower ball bearing are required. Both bearings shall be permanently lubricated by the oil, which fills the motor housing. The motor shaft shall be made of 300 or 400 series stainless steel and have a minimum diameter of .50".

7.01 SEALS

The pump shall have a unitized carbon / ceramic seal with stainless steel housings and spring equal to Crane Type 6A. The motor plate / housing interface shall be sealed with a Buna-N o-ring.

8.01 IMPELLER

The impeller shall be engineered thermoplastic elastomer, with pump out vanes on the back shroud to keep debris away from the seal area. It shall be threaded to the motor shaft.

9.01 CONTROLS

All units can be supplied with CSA and UL approved automatic wide angle tilt float switches. The switches shall be equipped with piggy back style plug that allows the pump to be operated manually without the removal of the pump in the event that a switch becomes inoperable. Manual Pumps are operable by means of a pump control panel.

10.01 PAINT

The exterior of the casting shall be protected with Powder Coat paint.

11.01 SUPPORT

The pump shall have cast iron support legs, enabling it to be a free standing unit. The legs will be high enough to allow 2" solids to enter the volute.

12.01 SERVICEABILITY

Components required for the repair of the pump shall be shipped within a period of 24 hours.

13.01 FACTORY ASSEMBLED TANK SYSTEMS WITH GUIDE RAIL AND QUICK DISCONNECT DISCHARGE

_____ Guide factory mounted rail system with pump suspended by means of bolt on quick disconnect which is sealed by means of nitrile grommets or o-rings. The Discharge piping shall be schedule 80 PVC and furnished with a check valve and PVC shut-off ball valve. The Tank shall be wound fiberglass or roto-molded plastic. An inlet hub shall be provided with the fiberglass systems.

_____ Stainless steel Guide Rail

_____ Zinc plated steel Guide Rail

_____ "diameter of basin size

_____ "height of basin size

_____ "distance from top of tank to discharge pipe outlet

_____ Fiberglass cover

_____ Structural foam polymer cover

_____ Steel cover

_____ Simplex System with Outdoor panel and alarm

_____ Duplex System with Outdoor panel and alarm

_____ Simplex System with Indoor panel and alarm

_____ Duplex System with Indoor panel and alarm

_____ Separate Outdoor Alarm

_____ Remote Outdoor Alarm

14.01 TESTING

The pump shall have a ground continuity check and the motor chamber shall be Hi-potted to test for electrical integrity, moisture content and insulation defects. The motor and volute housing shall be pressurized, and an air leak decay test is performed to ensure integrity of the motor housing. The pump shall be run, voltage current monitored, and the tester checks for noise or other malfunction.

15.01 QUALITY CONTROL

The pump shall be manufactured in an ISO 9001 certified Facility.

16.01 WARRANTY

Standard limited warranty shall be 3 years.

...