

Liberty Pumps®

Ascent™ II Macerating Toilet System

**Featuring RazorCut™ Technology
IST™ Switch Sensing and
CleanConnect™ Seal**

The complete system for convenient addition of a bathroom in remodeling projects and additions. Powerful macerating system pumps waste to existing sewer lines in the building or home – *up to 25' high and 150' horizontally. Accepts additional lavatory and tub/shower connections for a complete bathroom anywhere!

*Horizontal distance can vary with amount of vertical pumping head. Consult factory for additional sizing and performance information.

Performance: Powerful and quiet, the new RazorCut™ system with stainless steel blades provides superior cutting compared to other macerating toilets.

Appearance: Clean, compact and modular. The new CleanConnect™ seal system eliminates unsightly rubber couplers for connecting the toilet to the macerator box. Rear exiting discharge and vent connectors conceal piping when exiting directly to a wall.

Serviceability: Designed with a new removable access cover, the Ascent™ II is completely serviceable without removing the macerating unit from the toilet or disconnecting plumbing!

Functionality: LED's inform of power on, alarm condition or low battery condition. Touch pad buttons allow manual by-pass operation of the unit and alarm silencing.

Code Compliant: Meets ADA standards, ANSI 117.1, 1.28 gallon per flush, ASME A112.3.4 and CSA B45.9.

U.S. Patent #8,235,316,
#8,714,917, #8,769,730
and Patents Pending



innovate. evolve.



U.S. Patent #8,235,316,
#8,714,917, #8,769,730
and Patents Pending

Horizontal or Vertical Piping?

QuickFlip™ discharge and vent connectors allow for horizontal or vertical pipe connections. Simply unscrew the connector and rotate 180 degrees for optional connection.

Heavy-duty connectors are PVC solvent weld type 1" discharge with integral check valve (can be reduced to 3/4")

1-1/2" vent.

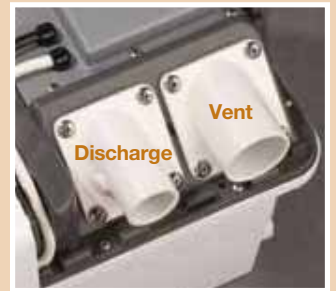

Macerator Features:

- Improved cutter design with RazorCut™ system. Stainless steel blades are replaceable with heavy-duty utility knife blades.
- Advance run technology assures macerator blades are running prior to debris entering the cutter basket.
- IST switch technology provides for complete flush-out of debris in the cutter area reducing potential clogging and jamming.
- Solid state electronic switch system provides intelligent data for system operation and eliminates older style mechanical or diaphragm switches.
- Auxiliary inlets on each side of unit allow for connection of a lavatory and/or shower. White couplers. Accepts 1-1/2" or 2" pipe.
- Built in alarm with 9 volt battery back-up and push-to-silence switch.
- LED's inform of power on, alarm condition and low alarm battery.
- Contoured tank design allows for wall molding to run behind macerator box!



Cord management system allows for hidden storage of excess power cord under the cover. No more cinched or twist tied cable loops hanging outside the system! An 8' white power cord is provided. Cord can be routed under the cover to exit either the left or right side!

Removable Service Panel



Integral heavy-duty rubber gaskets



Removable service panel on top cover provides easy access to system without removing plumbing or disconnecting the macerator from the toilet. No tools required.

RazorCut™ system is accessible for cleaning or blade replacement. Safety shut-off automatically disconnects electrical power when access cover is removed.



IST™ Intelligent Switch Technology

The Ascent II™ features solid state switch technology. Strategically located sensors activate the pump and alarm eliminating the need for troublesome diaphragm or mechanical float switches.

LED display informs of:

Power on • Alarm condition • Low battery condition

Functional touch pad on top of unit features:

Push to run override – allows manual run of the macerator overriding the IST™ switch.

Push-to-silence switch – silences the alarm.



inno



CleanConnect™ Seal eliminates unsightly rubber accordion style couplers and hose clamps for connection of toilet to the macerator box! Simply slide the macerator box with a robust integral seal onto the hub of the toilet. Macerator sits closer to toilet for a more professional appearance!

Specifications

Hp: 1/2

Volts: 115

Hz.: 60

Amps: 7.9

RPM: 3450

Thermally protected with automatic reset

Alarm: 115 volt with 9 volt battery back-up Battery included

Tank Material: ABS

Cutter Blades: Stainless Steel

Power Cord: 18-3, 8', white, right-angle plug holds close to wall

Maximum Fluid Temperature: 104 degrees F., 40 degrees C.



Extension Pipe

#K001184 (sold separately)

Includes decorative trim ring for a more professional looking installation. 18" Length works with 2" x 4" or 2" x 6" wall.

Toilet Features:

- Round or Elongated styles available
- ADA compliant
- HET (High Efficiency Toilet) 1.28 gpf (4.85 lpf)
- Improved flush design for one-flush operation
- White finish
- Installed flush valve kit
- 2-3/4" Trap
- Toilet seat included
- Insulated tank eliminates sweating in extreme climates



60 Hz. Performance Curve

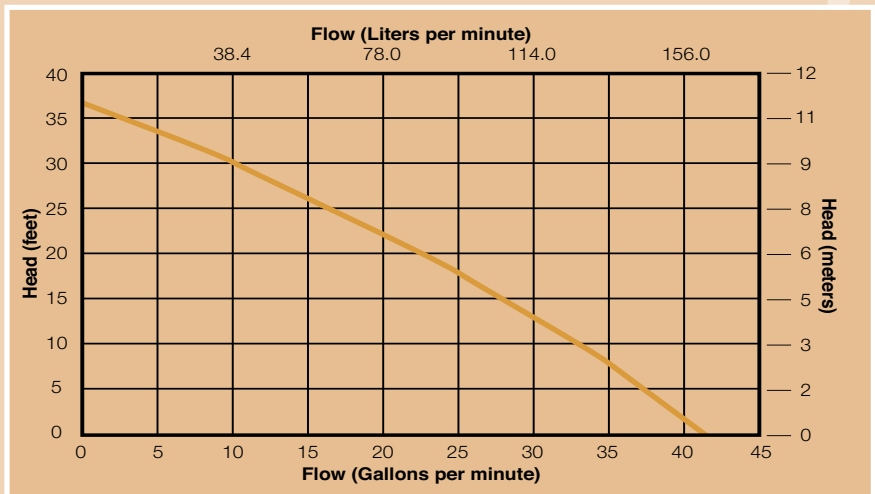

Note: Maximum shut-off head is 36 feet. Usable maximum head - assuming 150' of lateral discharge through 1" pipe is 25 feet. Consult factory for proper sizing and calculation of friction loss.

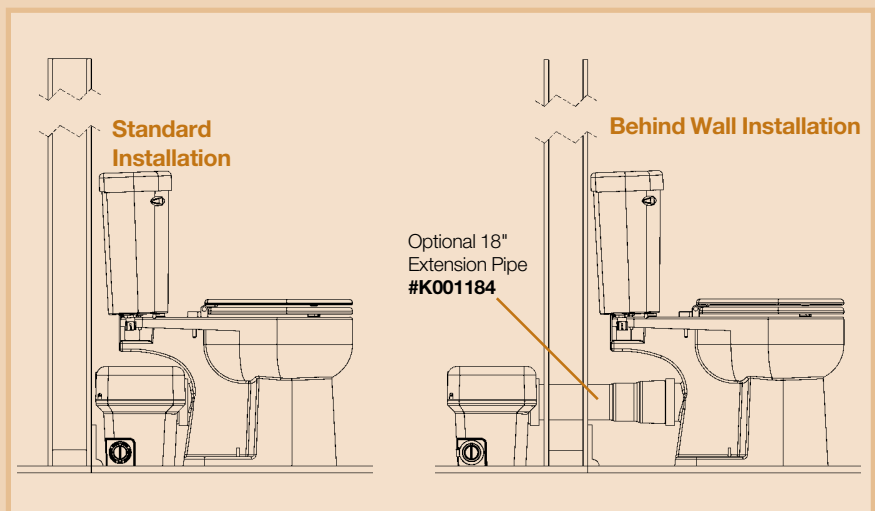

Ascent™ II

Macerating Toilet System



Dimensional data

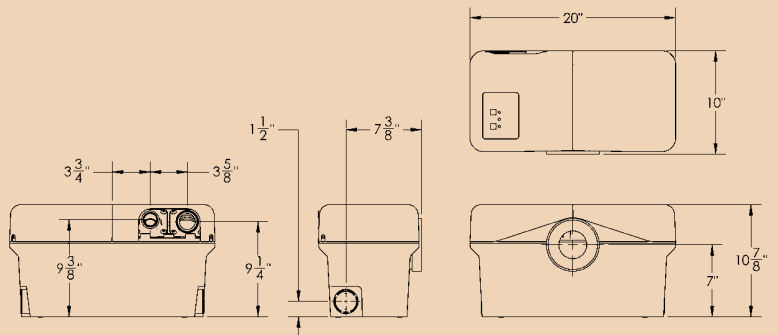
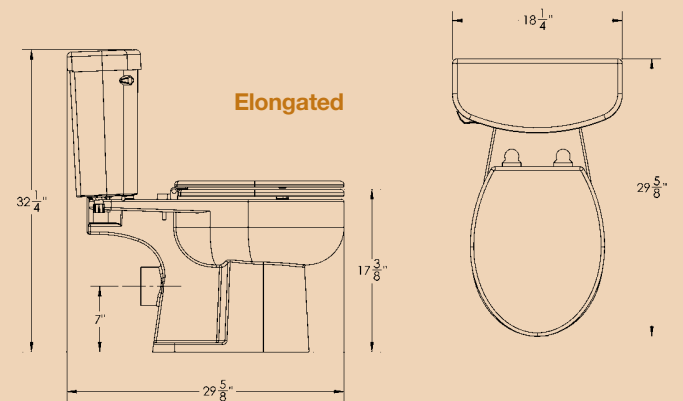
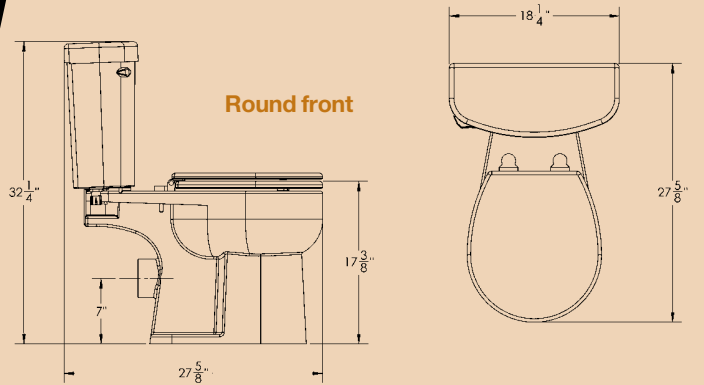

MODELS	Description	Wgt. lbs.
ASCENTII-ESW	Complete System: Macerator and elongated toilet – white	121
ASCENTII-RSW	Complete System: Macerator and round front toilet – white	115
ASCENTII-MUW	Macerator unit only	22
ASCENTII-TW	Toilet Tank and Lid, insulated with flush valve kit – white	34
ASCENTII-EW	Toilet Bowl, elongated – white	49
ASCENTII-RW	Toilet Bowl, round front – white	45
K001184	Extension Pipe, 4" x 18" with integral seal and trim ring	3



www.
libertypumps
.com

Liberty Pumps • 7000 Apple Tree Avenue • Bergen, New York 14416
Phone 800-543-2550 Fax (585) 494-1839

Specifications are subject to change without notice. Copyright © Liberty Pumps, Inc. 2014 All rights reserved. LLIT6675-R06/14