

PROJECT: _____	UNIT TAG: _____	QUANTITY: _____
REPRESENTATIVE: _____	TYPE OF SERVICE: _____	DATE: _____
ENGINEER: _____	SUBMITTED BY: _____	DATE: _____
CONTRACTOR: _____	APPROVED BY: _____	DATE: _____
	ORDER NO.: _____	DATE: _____

ALPHA 15-55 F 165

Circulator pumps, electronically controlled



Product photo could vary from the actual product

Conditions of Service	Pump Data	Motor Data
Flow: _____	Maximum operating pressure: 145 psi	P1 max: 5 .. 45 W
Head: _____	Liquid temperature range: 35.6 .. 230 °F	Rated voltage: 115 V
Efficiency: _____	Maximum ambient temperature: 104 °F	Main frequency: 60 Hz
Liquid: Water	Approvals: ETL, FCC	Enclosure class: IP42
Temperature: 68 °F	Pipe connection: GF 15/26	Insulation class: F
NPSH required: _____	Product number: 59896877	Motor protection: None
Viscosity: _____		Thermal protection: ELEC
Specific Gravity: 1.000		

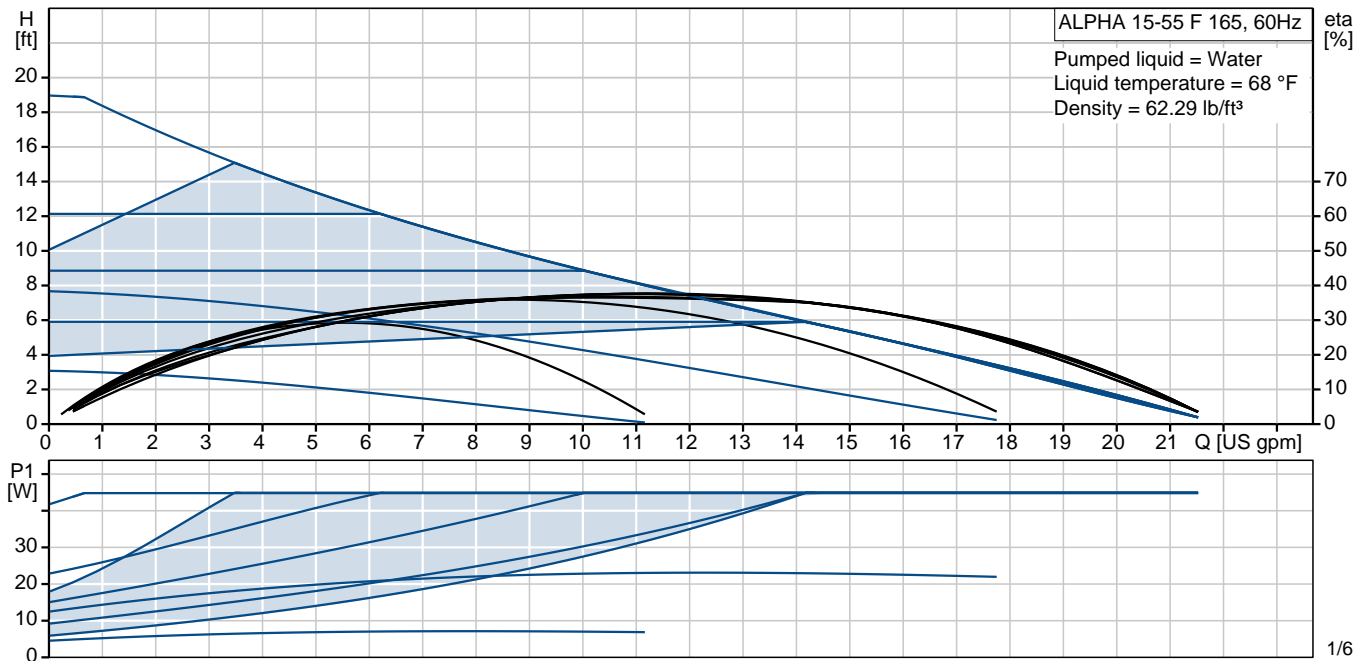

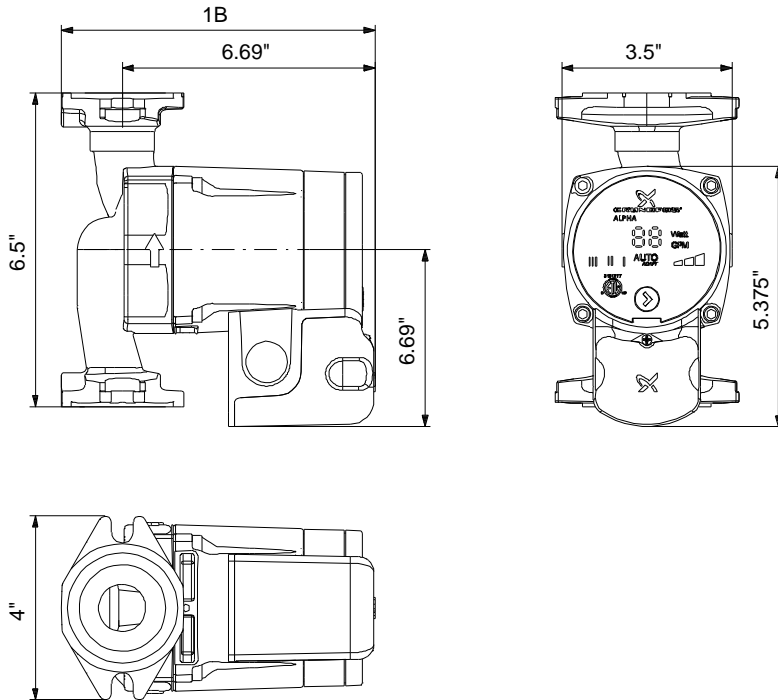

Materials:

Pump housing: /CAST IRON
DIN W.-Nr. GG15
ASTM 30 B
Impeller: Composite, PES

59896877 ALPHA 15-55 F 165 60 Hz

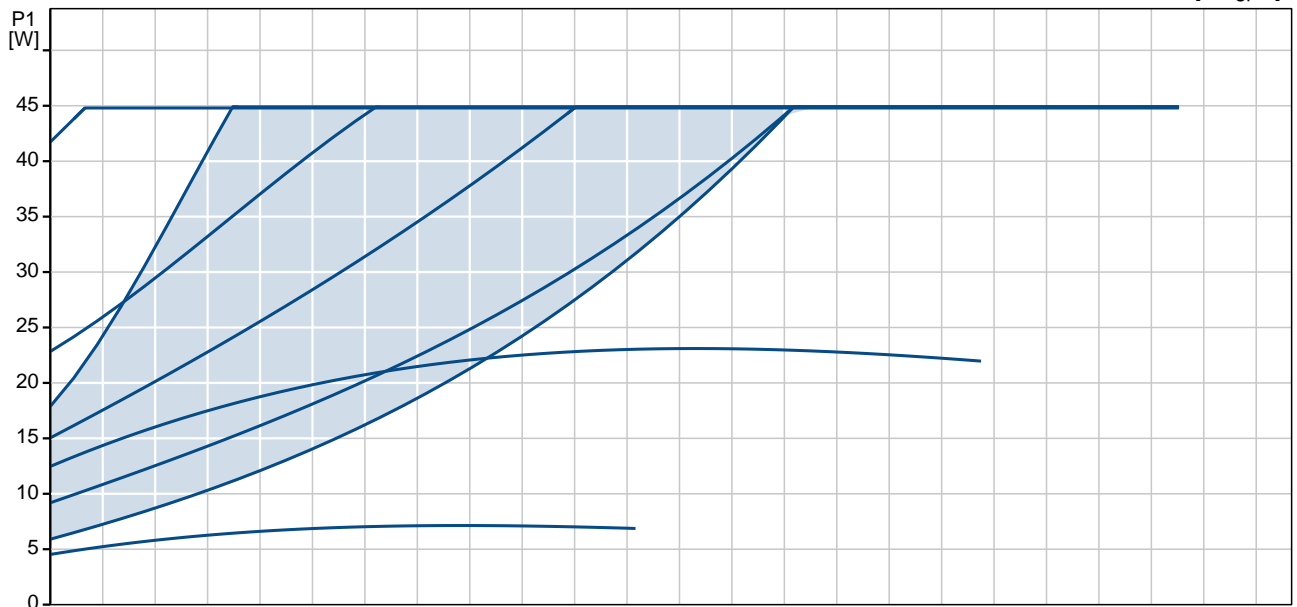
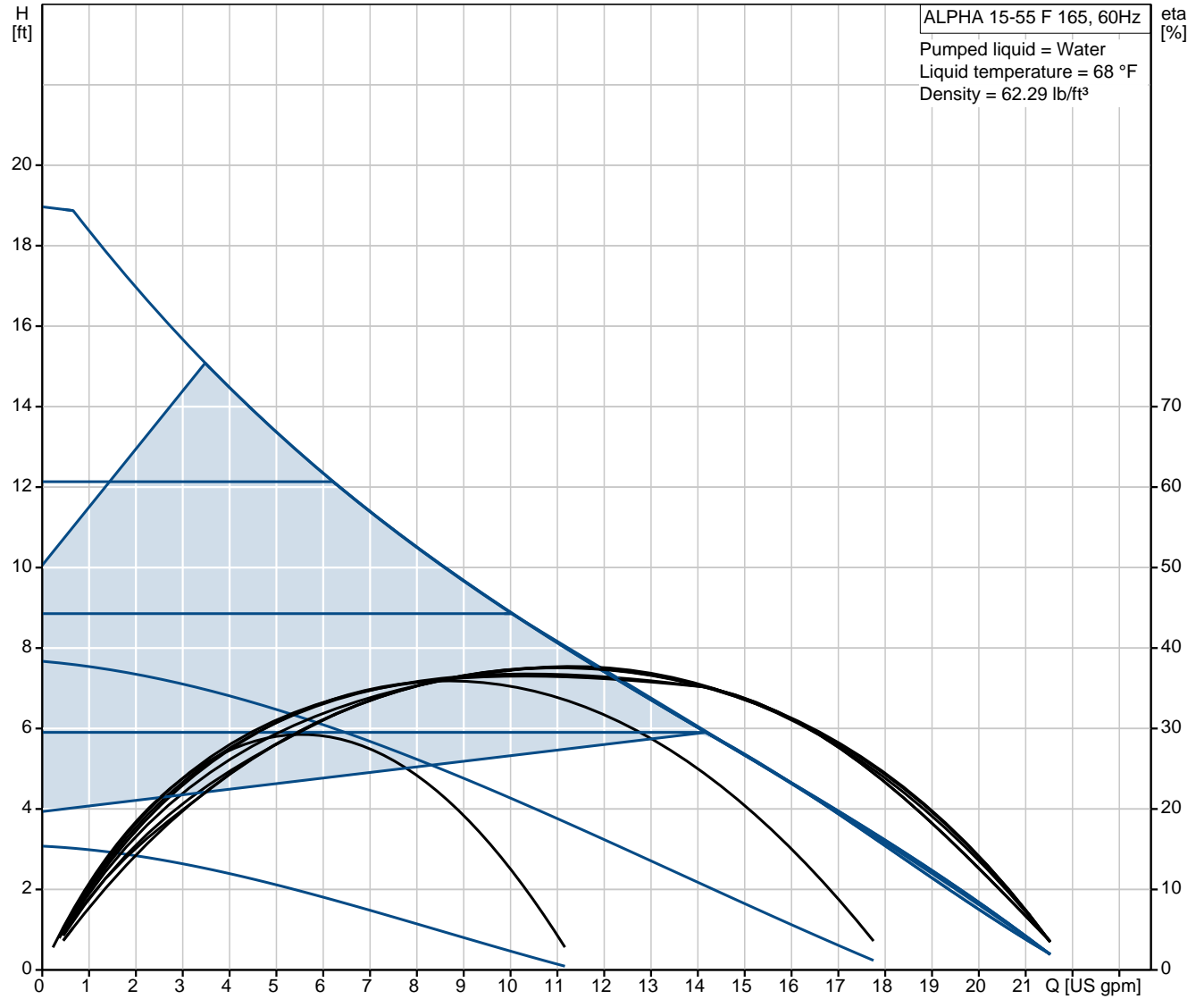

Description	Value
Product name:	ALPHA 15-55 F 165
Product Number:	59896877
EAN number:	5710620164376
Technical:	
Head max:	18 ft
TF class:	110
Approvals on nameplate:	ETL, FCC
Materials:	
Pump housing:	/CAST IRON DIN W.-Nr. GG15 ASTM 30 B
Impeller:	Composite, PES
Installation:	
Range of ambient temperature:	32 .. 104 °F
Maximum operating pressure:	145 psi
Pipe connection:	GF 15/26
Pressure stage:	PN 10
Port-to-port length:	6 1/2 in
Liquid:	
Pumped liquid:	Water
Liquid temperature range:	35.6 .. 230 °F
Liquid temp:	68 °F
Density:	62.29 lb/ft ³
Electrical data:	
Power input - P1:	5 .. 45 W
Maximum current consumption:	0.1 .. 0.65 A
Main frequency:	60 Hz
Rated voltage:	1 x 115 V
Enclosure class (IEC 34-5):	IP42
Insulation class (IEC 85):	F
Motor protection:	None
Thermal protec:	ELEC
Controls:	
Pos term box:	6H
Others:	
Gross weight:	7.5 lb
Energy label:	A
Sales region:	Namreg

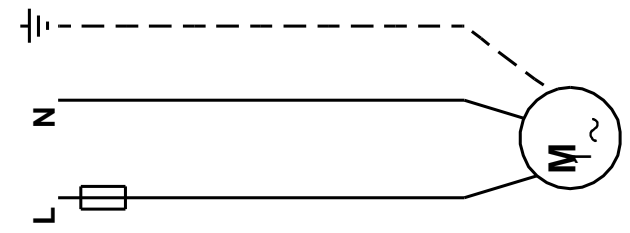
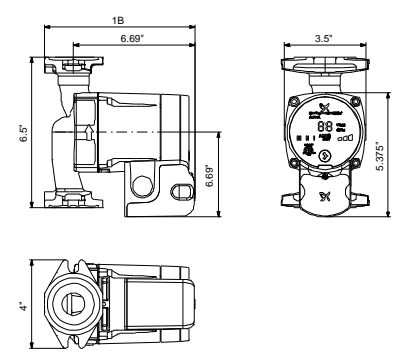
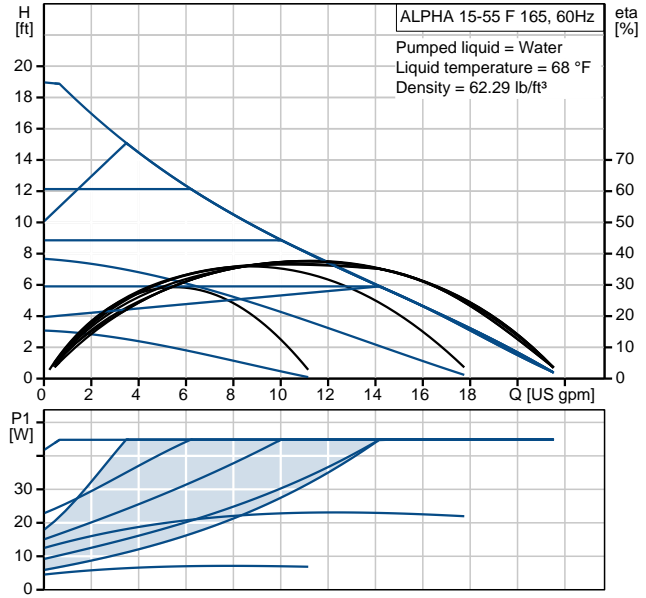

59896877 ALPHA 15-55 F 165 60 Hz

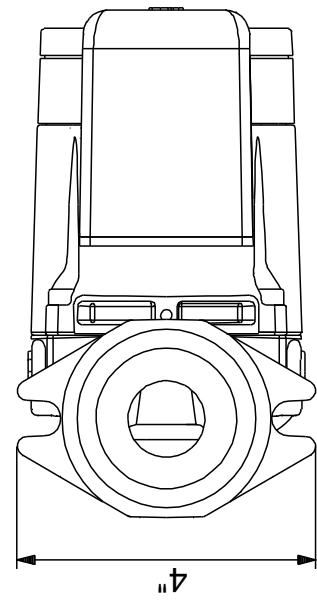
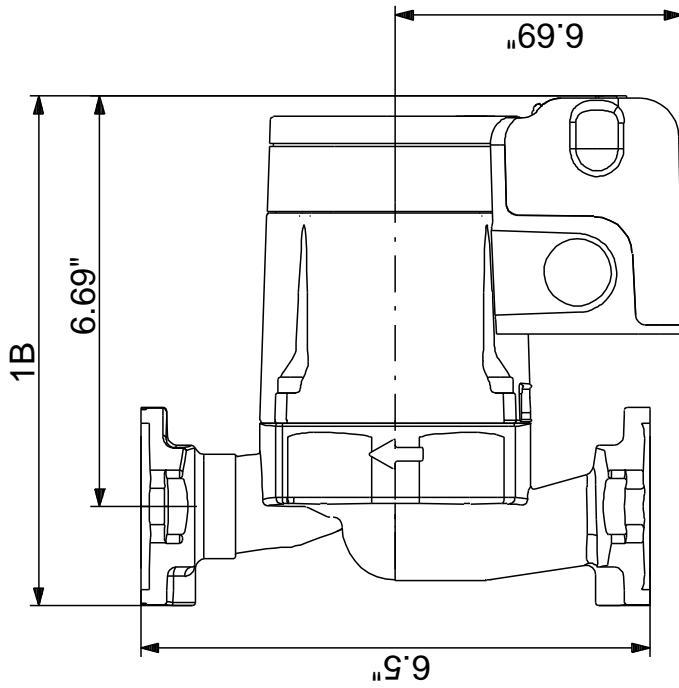
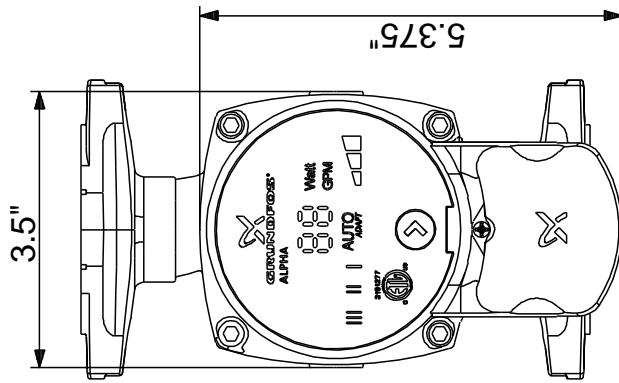

Note! All units are in [mm] unless others are stated.
Disclaimer: This simplified dimensional drawing does not show all details.

59896877 ALPHA 15-55 F 165 60 Hz

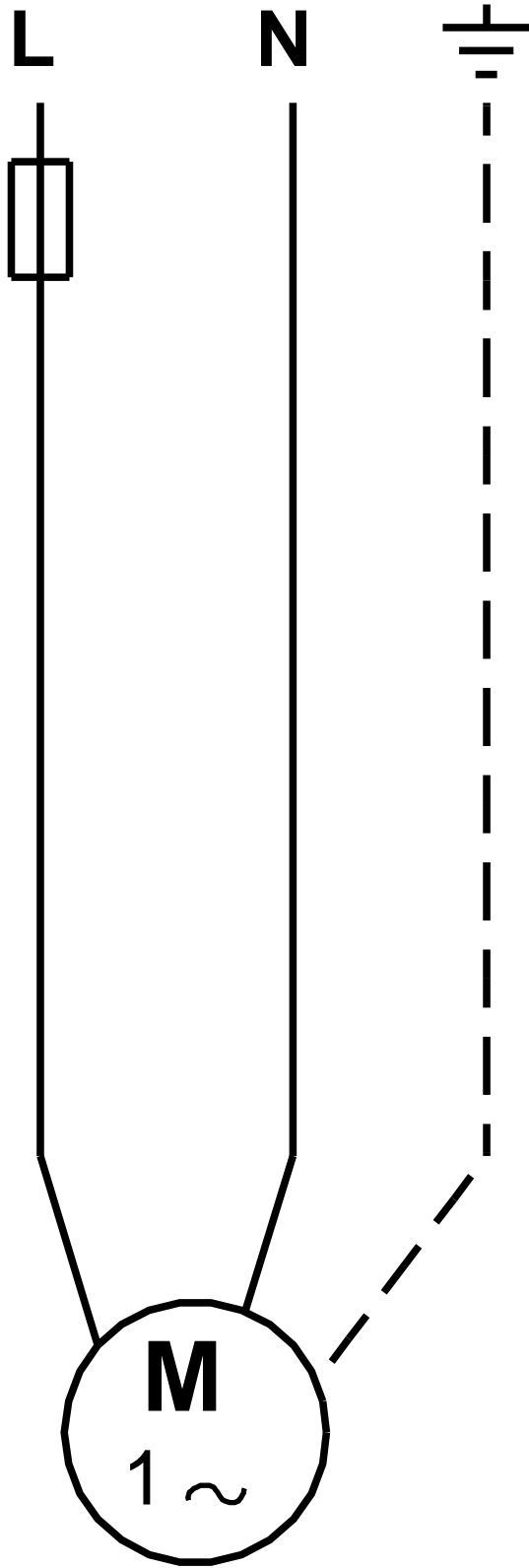

All units are [mm] unless otherwise presented.