



Air Conditioning & Heating

ARUF

MULTI-POSITION AIR HANDLER WITH NEW SMARTFRAME™ CONSTRUCTION

1½ TO 5 TONS



Standard Features

- All-aluminum evaporator coil
- Check flowrate expansion device for cooling-only and heat pump applications
- Direct-drive, multi-speed motor
- Transformer and blower time-delay on all units
- Easy single-bulb UV light compatibility
- Cabinet air leakage less than 2.0% at 1.0 inch H₂O when tested in accordance with ASHRAE standard 193
- Cabinet air leakage less than 1.4% at 0.5 inch H₂O when tested in accordance with ASHRAE standard 193
- AHRI Certified; ETL Listed

Cabinet Features

- New rigid SmartFrame™ cabinet
- 21" depth for easy attic access
- Galvanized leather grain-embossed finish
- Foil-faced insulation covers the entire blower case to reduce operating sound and cabinet condensation
- Glue-less cabinet insulation retention
- Deca-free thermoplastic coil pan
- Screw-less sides & back reduces condensation
- Easily convertible multi-position capability: upflow, downflow or horizontal
- Coil-mounting track for quick repositioning
- Tool-less filter access accommodates standard-size filters
- Power supply entry at top; low-voltage entry at top and on left side
- Easily convertible 4-way design
- Multiple independent electrical knockouts
- Heavy-gauge bottom plate

Contents

Nomenclature	2
Product Specifications	3
Dimensions	4
Airflow Data	5
Heat Kit Match-Ups	6
Wiring Diagram	7
Accessories	8



* Complete warranty details available from your local dealer or at www.goodmanmfg.com. To receive the 10-Year Parts Limited Warranty, online registration must be completed within 60 days of installation. Online registration is not required in California or Québec.



NOMENCLATURE

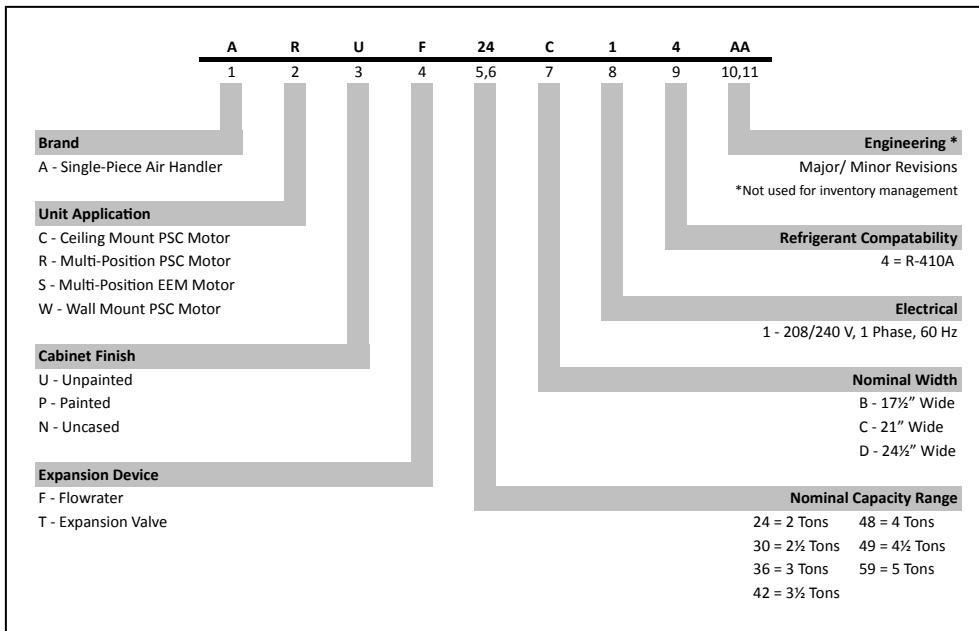

SPECIFICATIONS

	ARUF 18B14*	ARUF 24B14*	ARUF 30B14*	ARUF 30C14*	ARUF 36C14*	ARUF 42C14*	ARUF 48D14*	ARUF 60D14*
NOMINAL RATINGS								
Cooling (Btu/h)	18,000	24,000	30,000	36,000	36,000	42,000	48,000	60,000
Piston Size	0.049	0.057	0.065	0.071	0.071	0.074	0.078	0.088
BLOWER								
Diameter	9½"	9½"	9½"	10½"	10½"	10½"	10½"	11 ¹⁵ / ₁₆ "
Width	6"	6"	6"	8"	8"	10½"	10½"	10½"
Coil Drain Connect FPT	3/4"	3/4"	3/4"	3/4"	3/4"	3/4"	3/4"	3/4"
REFRIGERANT LINE CONNECTION SIZE								
Liquid	3/8"	3/8"	3/8"	3/8"	3/8"	3/8"	3/8"	3/8"
Suction	3/4"	3/4"	3/4"	3/4"	3/4"	7/8"	7/8"	7/8"
ELECTRICAL DATA								
Voltage	208/230	208/230	208/230	208/230	208/230	208/230	208/230	208/230
Min Circuit Ampacity	3/3	3/3	3/3	4/4	4/4	4/4	5/5	6/6
Max. Overcurrent Device (amps)	15/15	15/15	15/15	15/15	15/15	15/15	15/15	15/15
Min. / Max VAC	197/ 253	197/ 253	197/ 253	197/ 253	197/ 253	197/ 253	197/ 253	197/ 253
Blower Motor FLA/ HP	1.9/ 1/3	1.9/ 1/3	1.9/ 1/3	3.0/ 1/3	3.0/ 1/3	3.1/ 1/3	3.5/ 1/2	4.6/ 3/4
SHIP WEIGHT (LBS)	96	96	102	116	116	118	147	151

¹ CFM @.3 static

² Shipped with Coil

Note: For a properly matched system and piston sizing information, refer to Amana piston kit chart of the corresponding Amana® outdoor unit.

PRODUCT SPECIFICATIONS

DIMENSIONS

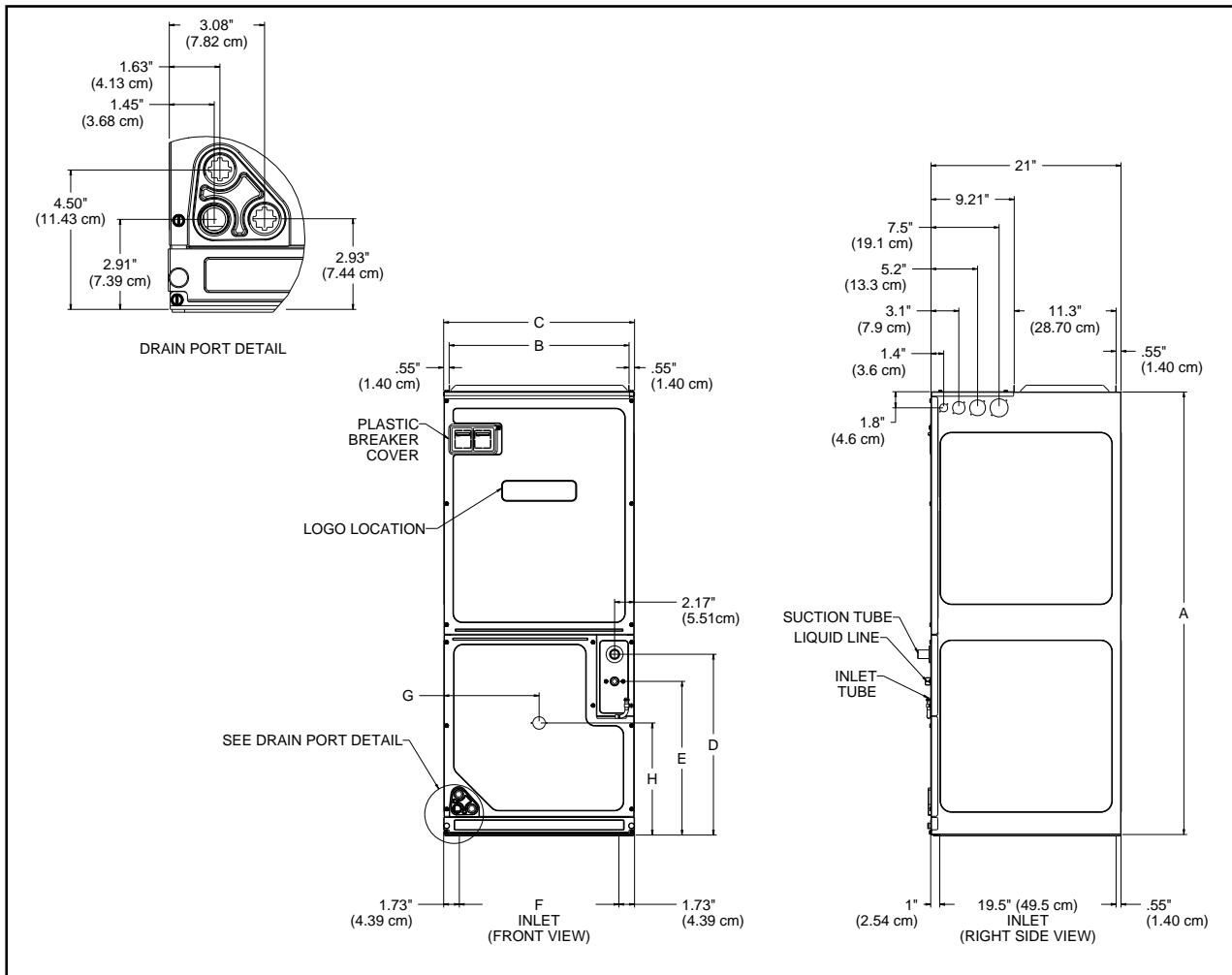

MODEL	A"	B"	C"	D"	E"	F"	G"	H"
ARUF18B14*	45	16 $\frac{3}{8}$	17 $\frac{1}{2}$	18	15	14 $\frac{3}{16}$	8 $\frac{13}{16}$	11 $\frac{15}{16}$
ARUF24B14*	45	16 $\frac{3}{8}$	17 $\frac{1}{2}$	18	15	14 $\frac{3}{16}$	8 $\frac{13}{16}$	11 $\frac{15}{16}$
ARUF30B14*	45	16 $\frac{3}{8}$	17 $\frac{1}{2}$	18	15	14 $\frac{3}{16}$	8 $\frac{13}{16}$	11 $\frac{15}{16}$
ARUF30C14*	49	19 $\frac{15}{16}$	21	20	17	17 $\frac{11}{16}$	10 $\frac{1}{2}$	12 $\frac{3}{8}$
ARUF36C14*	49	19 $\frac{15}{16}$	21	20	17	17 $\frac{11}{16}$	10 $\frac{1}{2}$	12 $\frac{3}{8}$
ARUF42C14*	49	19 $\frac{15}{16}$	21	20	17	17 $\frac{11}{16}$	10 $\frac{1}{2}$	12 $\frac{3}{8}$
ARUF48D14*	58	23 $\frac{5}{16}$	24 $\frac{1}{2}$	28 $\frac{3}{16}$	25 $\frac{3}{16}$	21 $\frac{3}{16}$	12 $\frac{5}{16}$	12 $\frac{3}{8}$
ARUF60D14*	58	23 $\frac{5}{16}$	24 $\frac{1}{2}$	28 $\frac{3}{16}$	25 $\frac{3}{16}$	21 $\frac{3}{16}$	12 $\frac{5}{16}$	12 $\frac{3}{8}$

AIRFLOW DATA

MODEL	MOTOR SPEED	STATIC PRESSURE (IN W.C) AIRFLOW (CFM)						
		0.1	0.2	0.3	0.4	0.5	0.6	0.7
ARUF18B14	High	1,150	1,095	1,045	1,025	950	865	775
	Medium	890	855	835	775	715	665	605
	Low	640	605	565	530	485	440	360
ARUF24B14	High	1,150	1,095	1,045	1,025	950	865	775
	Medium	890	855	835	775	715	665	605
	Low	640	605	565	530	485	440	360
ARUF30B14	High	1,145	1,085	1,020	950	900	845	765
	Medium	870	820	775	745	705	655	580
	Low	615	585	565	535	490	435	345
ARUF30C14	High	1,485	1,435	1,385	1,345	1,275	1,205	1,125
	Medium	1,300	1,270	1,235	1,195	1,130	1,060	955
	Low	1,040	1,015	980	930	865	790	705
ARUF36C14	High	1,485	1,435	1,385	1,345	1,275	1,205	1,125
	Medium	1,300	1,270	1,235	1,195	1,130	1,060	955
	Low	1,040	1,015	980	930	865	790	705
ARUF42C14	High	1,655	1,590	1,515	1,430	1,340	1,225	1,080
	Medium	1,435	1,370	1,300	1,220	1,150	1,025	925
	Low	1,115	1,040	995	930	845	770	675
ARUF48D14	High	1,990	1,915	1,810	1,765	1,690	1,585	1,435
	Medium	1,655	1,605	1,555	1,480	1,295	1,200	1,060
	Low	1,480	1,420	1,350	1,290	1,185	1,100	1,045
ARUF60D14	High	2,235	2,175	2,125	2,050	1,960	1,825	1,720
	Medium	2,030	1,970	1,885	1,800	1,690	1,600	1,495
	Low	1,615	1,535	1,455	1,355	1,270	1,185	1,090

NOTES

- Airflow data indicated is at 230V without air filter in place.
- The chart is for information only. For satisfactory operation, external static pressure must not exceed value shown on rating plate. The shaded area indicates ranges in excess of maximum recommended design external static pressure.
- Use the CFM adjustment factors of 0.98 for horizontal left and 0.96 for horizontal right & downflow orientations

HEAT KIT APPLICATIONS

MODEL	ARUF 18B14-A*	ARUF 24B14-A*	ARUF 24B14-B*	ARUF 30B14-A*	ARUF 30C14-B*	ARUF 36C14-A*	ARUF 36C14-B*	ARUF 42C14-A*	ARUF 48D14-A*	ARUF 60D14-A*
HKXS03XC*	X	X	X	X	X	X	X	X	X	X
HKXS05XC*	X	X	X	X	X	X	X	X	X	X
HKXS06XC*	X	X	X	X	X	X	X	X	X	X
HKXS08XC*	X	X	X	X	X	X	X	X	X	X
HKXS10XC*	X	X	X	X	X	X	X	X	X	X
HKSC05XC*	X	X	X	X	X	X	X	X	X	X
HKSC08XC*	X	X	X	X	X	X	X	X	X	X
HKSC10XC*	X	X	X	X	X	X	X	X	X	X
HKSC15XA*	---	---	---	X	X	X	X	X	X	X
HKSC15XB*	---	---	---	X	X	X	X	X	X	X
HKSC19CA*	---	---	---	---	X	X	X	X	---	---
HKSC19CB*	---	---	---	---	X	X	X	X	---	---
HKSC20DA*	---	---	---	---	---	---	---	---	X	X
HKSC20DB*	---	---	---	---	---	---	---	---	X	X

* Revision level that may or may not be designated

Note: Refer to the minimum airflow requirements for each of the heat kits

SINGLE-POINT KIT **

MODEL	HKSC15X*	HKSC19**	HKSC20**
SPW-01	X	X	X

** Must be installed along with any of the above compatible heat kits. This kit will fit any ARPT air handler as long as a compatible heat kit is installed in the unit.

Note: See HKS spec sheet and equipment data label for specific single-point rating.

ARUF WIRING DIAGRAM

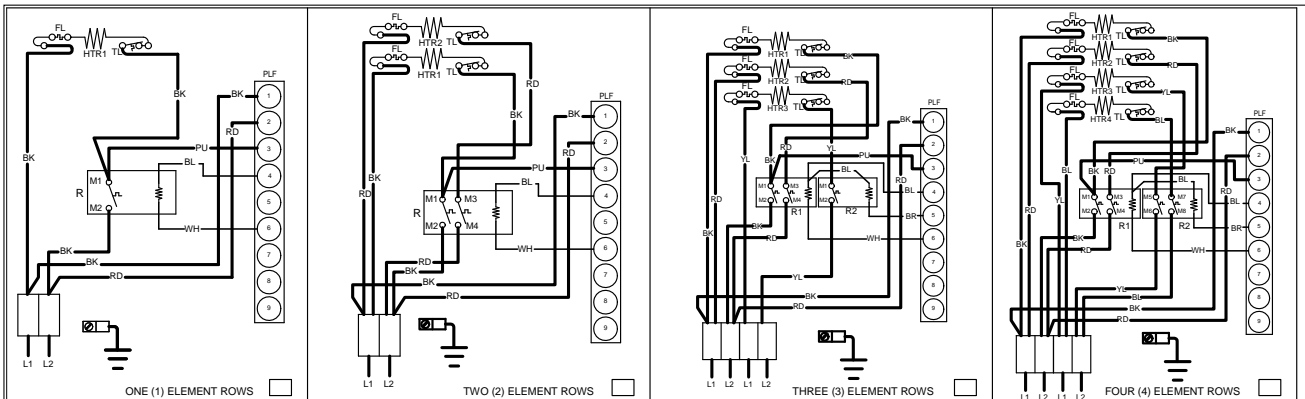

NOTE: WHEN INSTALLING HEATER KIT, ENSURE SPEED TAP IS NOT BELOW MINIMUM BLOWER SPEED (MBS) SPECIFIED FOR THE AIR HANDLER/HEATER KIT COMBINATION ON THIS UNITS SERIAL PLATE. AFTER INSTALLING OPTIONAL HEAT KIT, MARK AN "X" IN THE PROVIDED ABOVE. MARK ACCORDING TO THE NUMBER OF HEATER ELEMENT ROWS INSTALLED. NO MARK INDICATES NO HEAT KIT INSTALLED. 5 ELEMENT ROWS DATA SUPPLIED WITH HEATER KIT.

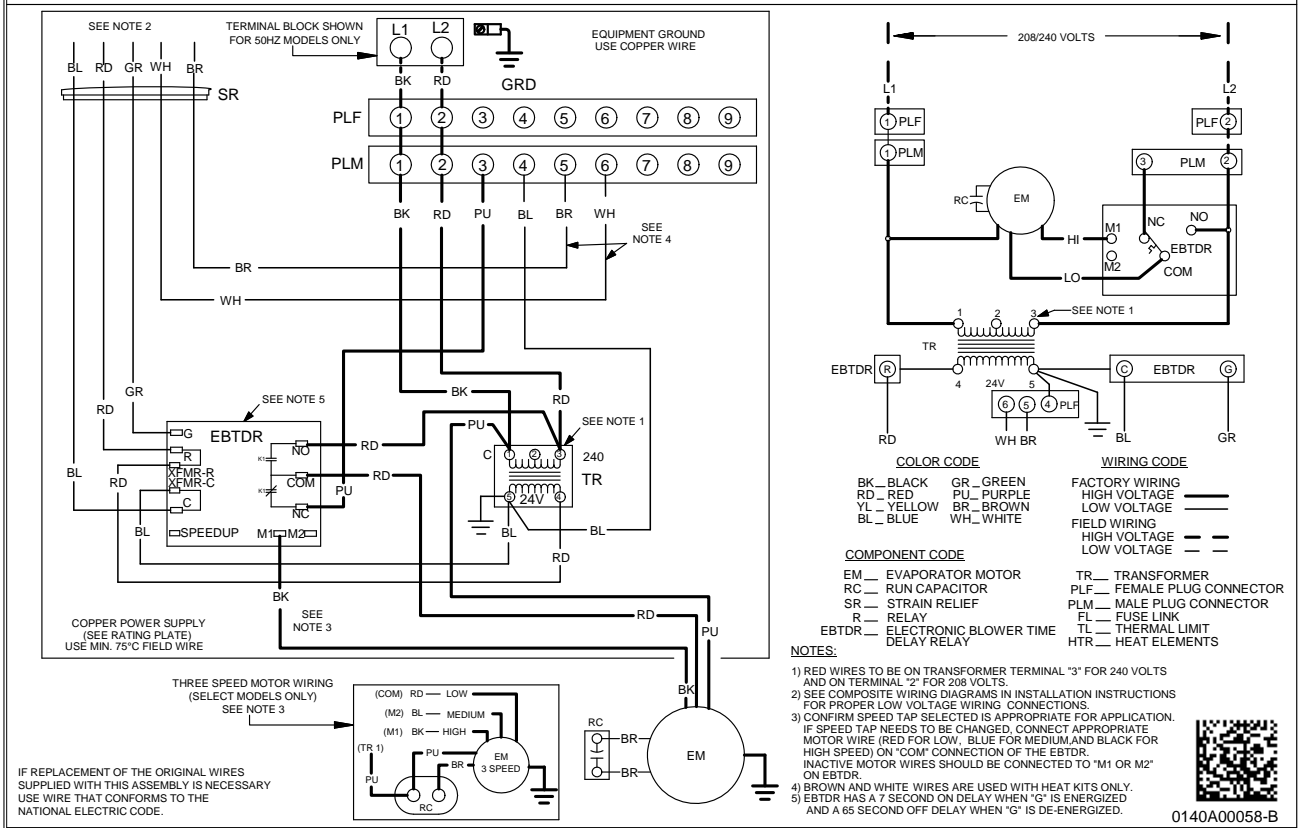

Wiring is subject to change. Always refer to the wiring diagram or the unit for the most up-to-date wiring.

WARNING

High Voltage: Disconnect all power before servicing or installing this unit. Multiple power sources may be present. Failure to do so may cause property damage, personal injury, or death.

ACCESSORIES

EXPANSION VALVE KITS FOR AIR CONDITIONING AND HEAT PUMP APPLICATIONS

KIT NUMBER	DESCRIPTION	APPLICATION	REFRIGERANT	TONNAGE: OUTDOOR UNIT
TX2N4A	Non-bleed Valve	AC or HP	R-410A	1½ - 2 Ton
TX3N4	Non-bleed Valve	AC or HP	R-410A	2½ - 3 Ton
TX5N4	Non-bleed Valve	AC or HP	R-410A	3½ - 5 Ton

DOWNFLOW INSULATION KIT

DFK-B	DFK-C	DFK-D
ARUF18B14**	ARUF30C14BA	ARUF48D14**
ARUF24B14**	ARUF36C14**	ARUF60D14**
ARUF30B14**	ARUF42C14**	

FILTERS

CHASSIS	PART #	SIZE
B	ALFH16201E	16.0" x 20.0"
C	ALFH1912201E	19.5" x 20.0"
D	ALFH20231E	23.0" x 20.0"