

INSTALLATION & OPERATING INSTRUCTIONS for A/GPG13 M SERIES W/R410A SINGLE PACKAGE GAS-ELECTRIC HEATING & COOLING UNIT

Affix this manual and Users Information Manual adjacent to the unit.

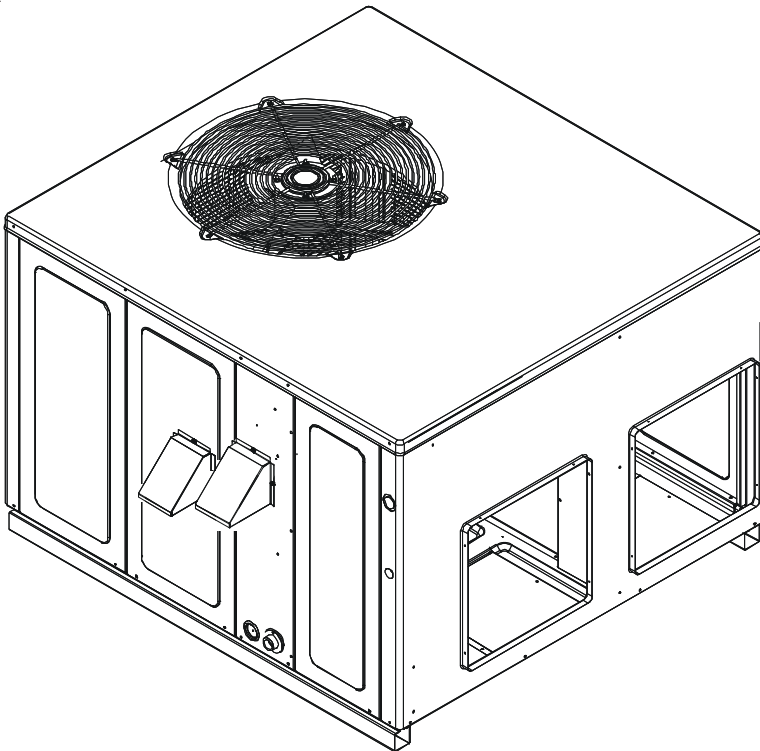

This Forced Air Central Unit Design Complies With Requirements Embodied in The American National Standard / National Standard of Canada Shown Below.
ANSI Z21.47•CSA-2.3 Central Furnaces



RECOGNIZE THIS SYMBOL AS A SAFETY PRECAUTION.

ATTENTION INSTALLING PERSONNEL

Prior to installation, thoroughly familiarize yourself with this Installation Manual. Observe all safety warnings. During installation or repair, caution is to be observed.

It is your responsibility to install the product safely and to educate the customer on its safe use.

These installation instructions cover the **outdoor** installation of single package gas electric heating and cooling units. See the Specification Sheet or Technical Manual applicable to your model* for information regarding accessories.

*NOTE: Please contact your distributor or our website for the applicable Specification Sheet or Technical Manual referred to in this manual.

IO-357E
3/2014

Goodman Manufacturing Company, L.P.
5151 San Felipe, Suite 500, Houston, TX 77056
www.goodmanmfg.com - or - www.amana-hac.com
© 2009 - 2010, 2012, 2014 Goodman Manufacturing Company, L.P.



Index

Replacement Parts	3
ORDERING PARTS	3
Safety Instructions	3
Unit location	4
ALL INSTALLATIONS:	4
GROUND LEVEL INSTALLATIONS ONLY:	4
ROOFTOP INSTALLATIONS ONLY:	4
ROOF CURB INSTALLATIONS ONLY:	5
General Information	5
TRANSPORTATION DAMAGE	6
Rigging Details	6
Gas Piping	6
HIGH ALTITUDE DERATE (U.S. INSTALLATIONS ONLY)	6
PIPING	6
GAS PIPING CHECKS	7
Propane Gas Installations	8
TANKS AND PIPING	8
Electrical Wiring	8
THERMOSTAT LOCATION	8
UNIT VOLTAGE	9
HEAT ANTICIPATOR SETTING	9
Circulating Air and Filters	10
AIRFLOW CONVERSION	10
DUCTWORK	10
FILTERS	10
Venting	11
FLUE HOOD INSTALLATION	11
Condensate Drain	11
CONDENSATE DRAIN CONNECTION	11
Normal Sequences of Operation	11
HEATING	11
COOLING	11
FAN ONLY	11
Startup, Adjustments, and Checks	11
HEATING STARTUP	11
GAS SUPPLY PRESSURE MEASUREMENT	12
GAS MANIFOLD PRESSURE MEASUREMENT AND ADJUSTMENT	13
COOLING STARTUP	15
Troubleshooting	15
IGNITION CONTROL ERROR CODES	15
ABNORMAL OPERATION - HEATING	15
ABNORMAL OPERATION - COOLING	16
Maintenance	16
FILTER REPLACEMENT OR CLEANING	16
CABINET FINISH MAINTENANCE	17
CLEAN OUTSIDE COIL (QUALIFIED SERVICER ONLY)	17
CONDENSER, EVAPORATOR, AND INDUCED DRAFT MOTORS	17
FLAME SENSOR (QUALIFIED SERVICER ONLY)	17
FLUE PASSAGES (QUALIFIED SERVICER ONLY)	17
CLEANING FLUE PASSAGES (QUALIFIED SERVICER ONLY)	17
MAIN BURNER FLAME (QUALIFIED SERVICER ONLY)	17
CLEANING BURNERS	17
Accessories and Functional Parts	18
SHEET METAL ACCESSORIES	18
FUNCTIONAL PARTS	18
GENERAL INFORMATION	18
APPENDIX	26
Unit Dimensions	26
Wiring Diagrams	27
Minimum Clearances	39
Recommended Filter Sizes	39

REPLACEMENT PARTS

ORDERING PARTS

When reporting shortages or damages, or ordering repair parts, give the complete unit model and serial numbers as stamped on the unit's nameplate.

Replacement parts for this appliance are available through your contractor or local distributor. For the location of your nearest distributor, consult the white business pages, the yellow page section of the local telephone book or contact:

CONSUMER AFFAIRS
GOODMAN MANUFACTURING COMPANY, L.P.
7401 SECURITY WAY
HOUSTON, TEXAS 77040
(877) 254-4729

SAFETY INSTRUCTIONS

To The Installer

Before installing this unit, please read this manual to familiarize yourself on the specific items which must be adhered to, including maximum external static pressure to unit, air temperature rise, minimum or maximum CFM and motor speed connections.

Keep this literature in a safe place for future reference.

WARNING

Do NOT connect to or use any device that is not design certified by Goodman for use with this unit. Serious property damage, personal injury, reduced unit performance and/or hazardous conditions may result from the use of such non-approved devices.

WARNING

If the information in these instructions is not followed exactly, a fire or explosions may result causing property damage, personal injury or loss of life.

- Do NOT store or use gasoline or other flammable vapors and liquids in the vicinity of this or any other appliance.

- WHAT TO DO IF YOU SMELL GAS:

- Do NOT try to light any appliance.
- Do NOT touch any electrical switch; do NOT use any phone in your building.
- Immediately call your gas supplier from a neighbor's phone. Follow the gas supplier's instructions.
- If you cannot reach your gas supplier, call the fire department.
- Installation and service must be performed by a qualified installer service agency or the gas supplier.

WARNING

Should overheating occur or the gas supply fail to shut off, turn off the manual gas shutoff valve external to the furnace before turning off the electrical supply.

WARNING

This product contains or produces a chemical or chemicals which may cause serious illness or death and which are known to the State of California to cause cancer, birth defects or other reproductive harm.

WARNING

HEATING UNIT SHOULD NOT BE UTILIZED WITHOUT REASONABLE, ROUTINE, INSPECTION, MAINTENANCE AND SUPERVISION. IF THE BUILDING IN WHICH ANY SUCH DEVICE IS LOCATED WILL BE VACANT, CARE SHOULD BE TAKEN THAT SUCH DEVICE IS ROUTINELY INSPECTED, MAINTAINED AND MONITORED. IN THE EVENT THAT THE BUILDING MAY BE EXPOSED TO FREEZING TEMPERATURES AND WILL BE VACANT, ALL WATER-BEARING PIPES SHOULD BE DRAINED, THE BUILDING SHOULD BE PROPERLY WINTERIZED, AND THE WATER SOURCE CLOSED. IN THE EVENT THAT THE BUILDING MAY BE EXPOSED TO FREEZING TEMPERATURES AND WILL BE VACANT, ANY HYDRONIC COIL UNITS SHOULD BE DRAINED AS WELL AND, IN SUCH CASE, ALTERNATIVE HEAT SOURCES SHOULD BE UTILIZED.

WARNING

To avoid property damage, personal injury or death, do not use this unit if any part has been under water. Immediately call a qualified service technician to inspect the furnace and to replace any part of the control system and any gas control having been under water.

WARNING

This unit must not be used as a "construction heater" during the finishing phases of construction on a new structure. This type of use may result in premature failure of the unit due to extremely low return air temperatures and exposure to corrosive or very dirty atmospheres.

WARNING

HIGH VOLTAGE

Disconnect ALL power before servicing or installing this unit. Multiple power sources may be present. Failure to do so may cause property damage, personal injury or death.





WARNING

To prevent the risk of property damage, personal injury, or death, do not store combustible materials or use gasoline or other flammable liquids or vapors in the vicinity of this appliance.

WARNING

ONLY individuals meeting (at a minimum) the requirements of an "entry level technician" as specified by the Air-Conditioning, Heating and Refrigeration Institute (AHRI) may use this information. Attempting to install or repair this unit without such background may result in product damage, personal injury or death.



 DANGER PELIGRO
 CARBON MONOXIDE POISONING HAZARD
Special Warning for Installation of Furnaces or Air Handling Units in Enclosed Areas such as Garages, Utility Rooms or Parking Areas
Carbon monoxide producing devices (such as an automobile, space heater, gas water heater, etc.) should not be operated in enclosed areas such as unventilated garages, utility rooms or parking areas because of the danger of carbon monoxide (CO) poisoning resulting from the exhaust emissions. If a furnace or air handler is installed in an enclosed area such as a garage, utility room or parking area and a carbon monoxide producing device is operated therein, there must be adequate, direct outside ventilation.
This ventilation is necessary to avoid the danger of CO poisoning which can occur if a carbon monoxide producing device continues to operate in the enclosed area. Carbon monoxide emissions can be (re)circulated throughout the structure if the furnace or air handler is operating in any mode.
CO can cause serious illness including permanent brain damage or death.
B10259-216

UNIT LOCATION

 WARNING
TO PREVENT POSSIBLE EQUIPMENT DAMAGE, PROPERTY DAMAGE, PERSONAL INJURY OR DEATH, THE FOLLOWING BULLET POINTS MUST BE OBSERVED WHEN INSTALLING THE UNIT.

ALL INSTALLATIONS:

- For proper flame pattern within the heat exchanger and proper condensate drainage, the unit must be mounted level.
- The flue outlet hood must be at least 12 inches from any opening through which flue gases could enter a building, and at least three feet above any forced air inlet located within ten feet. The economizer/manual fresh air intake/ motorized fresh air intake and combustion air inlet mounted on the unit are not affected by this restriction.
- To avoid possible corrosion of the heat exchanger, do not locate the unit in an area where the outdoor air (i.e. combustion air for the unit) will be frequently contaminated by compounds containing chlorine or fluorine. Common sources of such compounds include swimming pool chemicals and chlorine bleaches, paint stripper, adhesives, paints, varnishes, sealers, waxes (which are not yet dried) and solvents used during construction and remodeling. Various commercial and industrial processes may also be sources of chlorine/ fluorine compounds.

- To avoid possible illness or death of the building occupants, do NOT locate outside air intake device (economizer, manual fresh air intake, motorized fresh air intake) too close to an exhaust outlet, gas vent termination, or plumbing vent outlet. For specific distances required, consult local codes.
- Allow minimum clearances from the enclosure for fire protection, proper operation, and service access (see appendix). These clearances must be permanently maintained.
- The combustion air inlet and flue outlet hoods on the unit must never be obstructed. If used, do not allow the economizer/manual fresh air damper/ motorized fresh air damper to become blocked by snow or debris. In some climates or locations, it may be necessary to elevate the unit to avoid these problems.
- When the unit is heating, the temperature of the return air entering the unit must be between 50° F and 100° F.

GROUND LEVEL INSTALLATIONS ONLY:

- When the unit is installed on the ground adjacent to the building, a level concrete (or equal) base is recommended. Prepare a base that is 3" larger than the package unit footprint and a minimum of 3" thick.
- The base should also be located where no runoff of water from higher ground can collect in the unit.

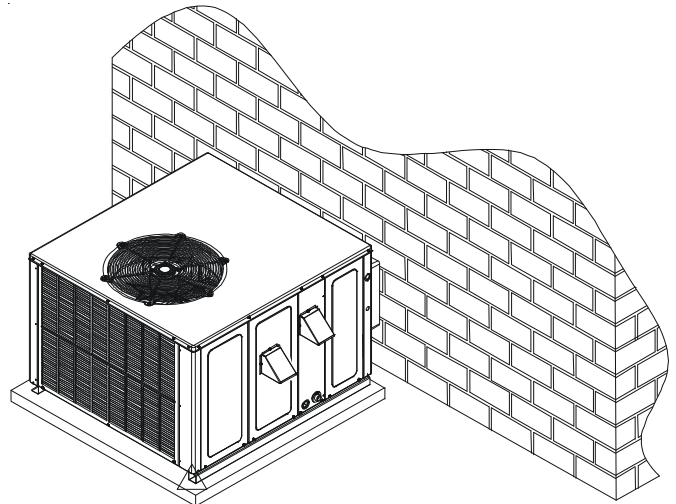

Outside Slab Installation

ROOFTOP INSTALLATIONS ONLY:

NOTE: To ensure proper condensate drainage, unit must be installed in a level position.

- To avoid possible property damage or personal injury, the roof must have sufficient structural strength to carry the weight of the unit(s) and snow or water loads as required by local codes. Consult a structural engineer to determine the weight capabilities of the roof.

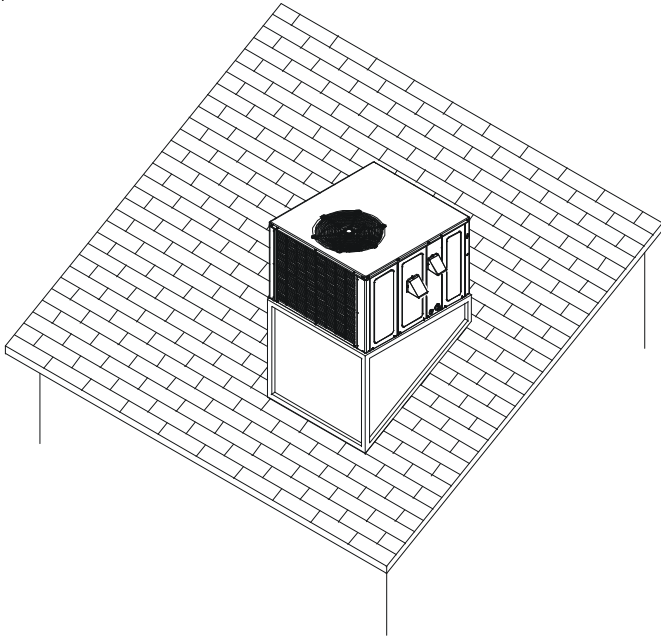

Rooftop Installation

- The unit may be installed directly on wood floors or on Class A, Class B, or Class C roof covering material.
- To avoid possible personal injury, a safe, flat surface for service personnel should be provided.

ROOF CURB INSTALLATIONS ONLY:

- Sufficient structural support must be determined prior to locating and mounting the curb and package unit.
- Ductwork must be constructed using industry guidelines. The duct work must be placed into the roof curb before mounting the package unit.
- Curb insulation, cant strips, flashing and general roofing material are furnished by the contractor.

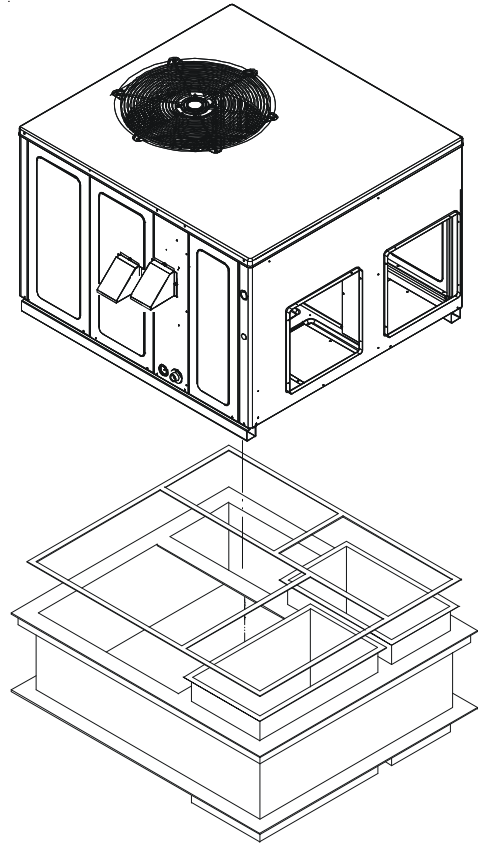

Roof Curb Installation

GENERAL INFORMATION

WARNING

TO PREVENT PROPERTY DAMAGE, PERSONAL INJURY OR DEATH, DUE TO FIRE, EXPLOSIONS, SMOKE, SOOT, CONDENSATION, ELECTRIC SHOCK OR CARBON MONOXIDE, THIS UNIT MUST BE PROPERLY INSTALLED, REPAIRED, OPERATED, AND MAINTAINED.

This unit is approved for outdoor installation ONLY. Rated performance is achieved after 72 hours of operation. Rated performance is delivered at the specified airflow. See outdoor unit specification sheet for split system models or product specification sheet for packaged and light commercial models. Specification sheets can be found at www.goodmanmfg.com for Goodman® brand products or www.amana-hac.com for Amana® brand products. Within either website, please select the residential or commercial products menu and then select the submenu for the type of product to be installed, such as air conditioners or heat pumps, to access a list of product pages that each contain links to that model's specification sheet.

To assure that your unit operates safely and efficiently, it must be installed, operated, and maintained in accordance with these installation and operating instructions, all local building codes and ordinances, or in their absence, with the latest edition of the National Fuel Gas Code NFPA54/ANSI Z223.1 and National Standard of Canada CAN/CSA B149 Installation Codes.

The heating and cooling capacities of the unit should be greater than or equal to the design heating and cooling loads of the area to be conditioned. The loads should be calculated by an approved method or in accordance with A.S.H.R.A.E. Guide or Manual J - Load Calculations published by the Air Conditioning Contractors of America.

Obtain from:
 American National Standards Institute
 1430 Broadway
 New York, NY 10018

TRANSPORTATION DAMAGE

Check the carton upon arrival for external damage. If damage is found, a request for inspection by carrier agent should be made in writing immediately.

Carefully inspect the unit for damage including damage to the cabinetry. Any bolts or screws which may have loosened in transit must be retightened. In the event of damage, the receiver should:

1. Make notation on delivery receipt of any visible damage to shipment or container.
2. Notify carrier promptly and request an inspection.
3. In case of concealed damage, carrier should be notified as soon as possible-preferably within 5 days.
4. File the claim with the following supporting documents:
 - a. Original Bill of Lading, certified copy, or indemnity bond.
 - b. Original paid freight bill or indemnity in lieu thereof.
 - c. Original invoice or certified copy thereof, showing trade and other discounts or reductions.
 - d. Copy of the inspection report issued by carrier representative at the time damage is reported to the carrier. The carrier is responsible for making prompt inspection of damage and for a thorough investigation of each claim. The distributor or manufacturer will not accept claims from dealers for transportation damage.

NOTE: When inspecting the unit for transportation damage, remove all packaging materials. Recycle or dispose of the packaging material according to local codes.

RIGGING DETAILS

WARNING
<p>TO PREVENT PROPERTY DAMAGE, THE UNIT SHOULD REMAIN IN AN UPRIGHT POSITION DURING ALL RIGGING AND MOVING OPERATIONS. TO FACILITATE LIFTING AND MOVING WHEN A CRANE IS USED, PLACE THE UNIT IN AN ADEQUATE CABLE SLING.</p>

Important: If using bottom discharge with roof curb, ductwork should be attached to the curb prior to installing the unit. Ductwork dimensions are shown in roof curb installation instructions.

Refer to the Roof Curb Installation Instructions for proper curb installation. Curbing must be installed in compliance with the National Roofing Contractors Association Manual.

Lower unit carefully onto roof mounting curb. While rigging unit, center of gravity will cause condenser end to be lower than supply air end.

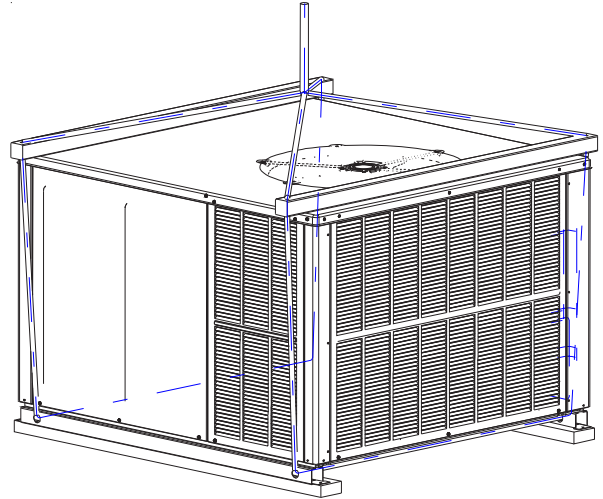

Rigging

GAS PIPING

IMPORTANT NOTE: This unit is factory set to operate on natural gas at the altitudes shown on the rating plate.

WARNING
<p>TO AVOID PROPERTY DAMAGE, PERSONAL INJURY OR DEATH WHEN EITHER USING PROPANE GAS ALONE OR AT HIGHER ALTITUDES, OBTAIN AND INSTALL THE PROPER CONVERSION KIT(S). FAILURE TO DO SO CAN RESULT IN UNSATISFACTORY OPERATION AND/OR EQUIPMENT DAMAGE. HIGH ALTITUDE KITS ARE FOR U.S. INSTALLATIONS ONLY AND ARE NOT APPROVED FOR USE IN CANADA.</p>

The rating plate is stamped with the model number, type of gas and gas input rating. Make sure the unit is equipped to operate on the type of gas available. Conversion to LP gas is permitted with the use of the factory authorized conversion kit LPT-03. (LPT-00A may be used on models with AA revisions. LPT-03 is compatible with both the White Rodgers and the Honeywell gas valves.)

Inlet Gas Pressure	
Natural	Min. 5.0" W.C., Max. 10.0" W.C.
Propane	Min. 11.0" W.C., Max. 13.0" W.C.

Inlet Gas Pressure Must Not Exceed the Maximum Value Shown in Table Above.

The minimum supply pressure should not vary from that shown in the table above because this could prevent the unit from having dependable ignition. In addition, gas input to the burners must not exceed the rated input shown on the rating plate. Overfiring of the unit could result in premature heat exchanger failure.

HIGH ALTITUDE DERATE (U.S. INSTALLATIONS ONLY)

IMPORTANT NOTE: The gas/electric units naturally derate with altitude. Do not attempt to increase the firing rate by changing orifices or increasing the manifold pressure. This can cause poor combustion and equipment failure. At all altitudes, the manifold pressure must be within 0.3 inches W.C. of that listed on the nameplate for the fuel used. At all altitudes and with either fuel, the air temperature rise must be within the range listed on the unit nameplate. Refer to the Installation Manual provided with the LP kit for conversion from natural gas to propane gas and for altitude adjustments.

NOTE: Up to 7,000 feet, no changes are required; above 7,000 feet, refer to High Altitude Kit HA-02.

PIPING

IMPORTANT NOTE: To avoid possible unsatisfactory operation or equipment damage due to under firing of equipment, do not undersize the natural/propane gas piping from the meter/tank to the unit. When sizing a trunk line, include all appliances on that line that could be operated simultaneously.

The rating plate is stamped with the model number, type of gas and gas input rating. Make sure the unit is equipped to operate on the type of gas available. The gas line installation must comply with local codes, or in the absence of local codes, with the latest edition of the National Fuel Gas Code NFPA 54/ANSI Z223.1.

Natural Gas Connection

Length of Pipe in Feet	Nominal Black Pipe Size (inches)				
	1/2	3/4	1	1 1/4	1 1/2
10	132	278	520	1050	1600
20	92	190	350	730	1100
30	73	152	285	590	980
40	63	130	245	500	760
50	56	115	215	440	670
60	50	105	195	400	610
70	46	96	180	370	560
80	43	90	170	350	530
90	40	84	160	320	490
100	38	79	150	305	460

Pressure = .50 PSIG or less and Pressure Drop of 0.3" W.C. (Based on 0.60 Specific Gravity Gas)

$$CFH = \frac{BTUH \text{ Furnace Input}}{\text{Heating Value of Gas (BTU/Cubic Foot)}}$$

Refer to the Proper Piping Practice drawing for the general layout at the unit. The following rules apply:

1. Use black iron pipe and fittings for the supply piping. The use of a flex connector and/or copper piping is permitted as long as it is in agreement with local codes.
2. Use pipe joint compound on male threads only. Pipe joint compound must be resistant to the action of the fuel used.
3. Use ground joint unions.
4. Install a drip leg to trap dirt and moisture before it can enter the gas valve. The drip leg must be a minimum of three inches long.
5. Use two pipe wrenches when making connection to the gas valve to keep it from turning.
6. Install a manual shut-off valve in a convenient location (within six feet of unit) between the meter and the unit.
7. Tighten all joints securely.
8. The unit must be connected to the building piping by one of the following methods:
 - Rigid metallic pipe and fittings
 - Semirigid metallic tubing and metallic fittings (Aluminum alloy tubing must not be used in exterior locations)
 - Listed gas appliance connectors used in accordance with the terms of their listing that are completely in the same room as the equipment
 - In the prior two methods above the connector or tubing must be protected from physical and thermal damage. Aluminum alloy tubing and connectors must be coated to protect against external corrosion when in contact with masonry, plaster or insulation or are subject to repeated wettings by liquids (water - not rain water, detergents or sewage)

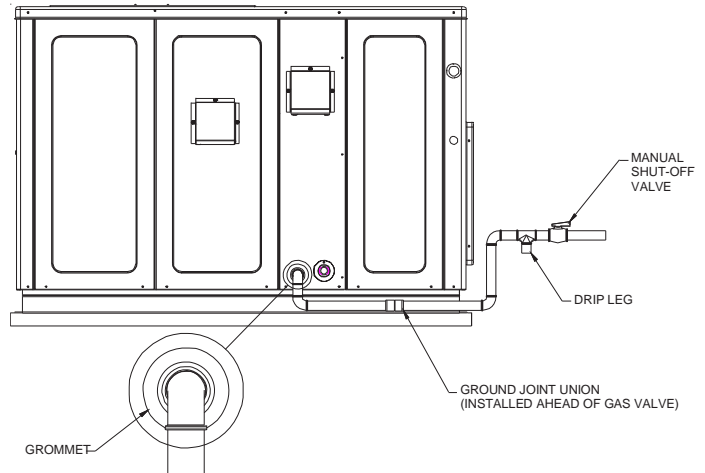

Proper Piping Practice

NOTE: The unit gas supply entrance is factory sealed with plugs. Keep plugs in place until gas supply is ready to be installed. Once ready, replace the plugs with the supplied grommets and install gas supply line.

GAS PIPING CHECKS

CAUTION

TO PREVENT PROPERTY DAMAGE OR PERSONAL INJURY DUE TO FIRE, THE FOLLOWING INSTRUCTIONS MUST BE PERFORMED REGARDING GAS CONNECTIONS AND PRESSURE TESTING:

- THE UNIT AND ITS GAS CONNECTIONS MUST BE LEAK TESTED BEFORE PLACING IN OPERATION. BECAUSE OF THE DANGER OF EXPLOSION OR FIRE, NEVER USE A MATCH OR OPEN FLAME TO TEST FOR LEAKS. NEVER EXCEED SPECIFIED PRESSURES FOR TESTING. HIGHER PRESSURE MAY DAMAGE GAS VALVE AND CAUSE OVERFIRING WHICH MAY RESULT IN PREMATURE HEAT EXCHANGE FAILURE.
- THIS UNIT AND ITS SHUT-OFF VALVE MUST BE DISCONNECTED FROM THE GAS SUPPLY DURING ANY PRESSURE TESTING OF THAT SYSTEM AT TEST PRESSURES IN EXCESS OF 1/2 PSIG (3.48 kPA).
- THIS UNIT MUST BE ISOLATED FROM THE GAS SUPPLY SYSTEM BY CLOSING ITS MANUAL SHUT-OFF VALVE DURING ANY PRESSURE TESTING OF THE GAS SUPPLY PIPING SYSTEM AT TEST PRESSURES EQUAL TO OR LESS THAN 1/2 PSIG (3.48 kPA).

WARNING

TO AVOID PROPERTY DAMAGE OR PERSONAL INJURY, BE SURE THERE IS NO OPEN FLAME IN THE VICINITY DURING AIR BLEEDING.

There will be air in the gas supply line after testing for leaks on a new installation. Therefore, the air must be bled from the line by loosening the ground joint union until pure gas is expelled. Tighten union and wait for five minutes until all gas has been dissipated in the air. Be certain there is no open flame in the vicinity during air bleeding procedure. The unit is placed in operation by closing the main electrical disconnect switch for the unit.

PROPANE GAS INSTALLATIONS

WARNING

TO AVOID PROPERTY DAMAGE, PERSONAL INJURY OR DEATH DUE TO FIRE OR EXPLOSION CAUSED BY A PROPANE GAS LEAK, INSTALL A GAS DETECTING WARNING DEVICE. SINCE RUST CAN REDUCE THE LEVEL OF ODORANT IN PROPANE GAS, A GAS DETECTING WARNING DEVICE IS THE ONLY RELIABLE WAY TO DETECT A PROPANE GAS LEAK. CONTACT A LOCAL PROPANE GAS SUPPLIER ABOUT INSTALLING A GAS DETECTING WARNING DEVICE.

IMPORTANT NOTE: Propane gas conversion kits must be installed to convert units to propane gas.

All propane gas equipment must conform to the safety standards of the National Board of Fire Underwriters (See NBFU Manual 58).

For satisfactory operation, propane gas supply pressure must be within 9.7 - 10.3 inches W.C. at the manifold with all gas appliances in operation. Maintaining proper gas pressure depends on three main factors:

1. Vaporization rate, which depends on (a) temperature of the liquid, and (b) wetted surface area of the container or containers.
2. Proper pressure regulation.
3. Pressure drop in lines between regulators, and between second stage regulator and the appliance. Pipe size required will depend on length of pipe run and total load of all appliances.

TANKS AND PIPING

Complete information regarding tank sizing for vaporization, recommended regulator settings and pipe sizing is available from most regulator manufacturers and propane gas suppliers.

Since propane gas will quickly dissolve white lead or most standard commercial compounds, special pipe dope must be used. Shellac base compounds resistant to the actions of liquefied petroleum gases such as Gasolac®, Stalactic®, Clyde's® or John Crane® are satisfactory.

See below for typical propane gas piping.

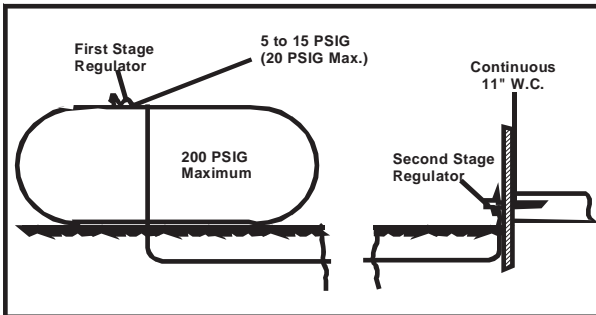

Typical Propane Gas Piping

Sizing Between First and Second Stage Regulator
Maximum Propane Capacities listed are based on 1 PSIG Pressure Drop at 10 PSIG Setting. Capacities in 1,000 BTU/HR

PIPE OR TUBING LENGTH, FEET	TUBING SIZE, O.D., TYPE L					NOMINAL PIPE SIZE, SCHEDULE 40	
	3/8"	1/2"	5/8"	3/4"	7/8"	1/2"	3/4"
30	309	700	1,303	2,205	3,394	1,843	3,854
40	265	599	1,115	1,887	2,904	1,577	3,298
50	235	531	988	1,672	2,574	1,398	2,923
60	213	481	896	1,515	2,332	1,267	2,649
70	196	446	824	1,394	2,146	1,165	2,437
80	182	412	767	1,297	1,996	1,084	2,267
90	171	386	719	1,217	1,873	1,017	2,127
100	161	365	679	1,149	1,769	961	2,009
150	130	293	546	923	1,421	772	1,613
200	111	251	467	790	1,216	660	1,381
250	90	222	414	700	1,078	585	1,224
300	89	201	378	634	976	530	1,109
350	82	185	345	584	898	488	1,020
400	76	172	321	543	836	454	949

To convert to Capacities at 15 PSIG Settings -- Multiply by 1.130
To convert to Capacities at 5 PSIG Settings -- Multiply by 0.879

Sizing Between Single or Second Stage Regulator and Appliance*
Maximum Propane Capacities Listed are Based on 1/2" W.C. Pressure Drop at 11" W.C. Setting. Capacities in 1,000 BTU/HR

PIPE OR TUBING LENGTH, FEET	TUBING SIZE, O.D., TYPE L					NOMINAL PIPE SIZE, SCHEDULE 40				
	3/8"	1/2"	5/8"	3/4"	7/8"	1/2"	3/4"	1"	1-1/4"	1-1/2"
10	49	110	206	348	539	291	608	1,146	2,353	3,525
20	34	76	141	239	368	200	418	788	1,617	2,423
30	27	61	114	192	296	161	336	632	1,299	1,946
40	23	52	97	164	253	137	284	541	1,111	1,665
50	20	46	86	146	224	122	255	480	985	1,476
60	19	42	78	132	203	110	231	436	892	1,337
80	16	36	67	113	174	94	198	372	764	1,144
100	14	32	59	100	154	84	175	330	677	1,014
125	12	28	52	89	137	74	155	292	600	899
150	11	26	48	80	124	67	141	265	544	815
200	10	22	41	69	106	58	120	227	465	697
250	9	19	36	61	94	51	107	201	412	618
300	8	18	33	55	85	46	97	182	374	560
350	7	16	30	51	78	43	89	167	344	515
400	7	15	28	47	73	40	83	156	320	479

*DATA IN ACCORDANCE WITH NFPA PAMPHLET NO. 54

Table 3 - Propane Gas Pipe Sizing

WARNING

TO PREVENT PROPERTY DAMAGE OR SERIOUS PERSONAL INJURY DUE TO FIRE OR EXPLOSION CAUSED BY A PROPANE GAS LEAK, INSTALL A GAS DETECTING WARNING DEVICE.

IF THE PROPANE GAS UNIT IS INSTALLED IN AN EXCAVATED AREA OR A CONFINED SPACE, A WARNING DEVICE IS REQUIRED DUE TO:

- PROPANE GAS IS HEAVIER THAN AIR AND ANY LEAKING GAS CAN SETTLE IN ANY LOW AREAS OR CONFINED SPACES.
- PROPANE GAS ODORANT MAY FADE, MAKING THE GAS UNDETECTABLE EXCEPT WITH A WARNING DEVICE.

ELECTRICAL WIRING

THERMOSTAT LOCATION

Mount the thermostat approximately five feet above the floor, in an area that has an inside, vibration-free wall and has good air circulation.

Movement of air must not be obstructed by furniture, door, draperies, etc. The thermostat must not be mounted where it will be affected by drafts, hot or cold water pipes or air ducts in walls, radiant heat from fireplace, lamps, the sun, television, etc. Consult the Instruction Sheet packaged with thermostat for mounting instructions.

All units have one stage of heating and one stage of mechanical cooling. Units which will have economizers may use thermostats with one or two stages of cooling.

WARNING

HIGH VOLTAGE
DISCONNECT ALL POWER BEFORE SERVICING OR CHANGING ANY ELECTRICAL WIRING TO THIS UNIT.
MULTIPLE POWER SOURCES MAY BE PRESENT. FAILURE TO DO SO MAY CAUSE PROPERTY DAMAGE, PERSONAL INJURY OR DEATH.

The units are designed for operation on 60 hertz current and at voltages as shown on the rating plate. All internal wiring in the unit is complete. It is necessary to bring in the power supply to the contactor as shown on the unit wiring diagram which is supplied with each unit. 24 volt wiring must be connected between the unit control panel and the room thermostat.

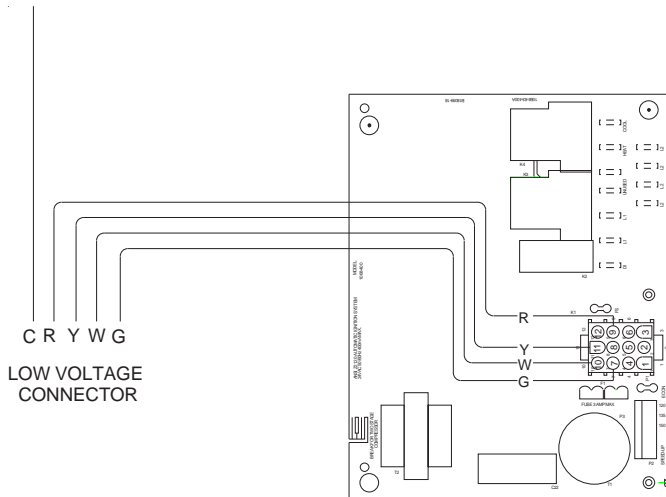

Low Voltage Wiring

Refer to the unit wiring diagram for electrical connections. When installed, the unit must be electrically grounded in accordance with local codes or in the absence of local codes, with the National Electrical Code, ANSI/NFPA No. 70, and/or the CSA C22.1 Electrical Code. Ensure low voltage connections are waterproof.

WARNING

TO AVOID THE RISK OF ELECTRICAL SHOCK, WIRING TO THE UNIT MUST BE POLARIZED AND GROUNDED.

CAUTION

TO AVOID PROPERTY DAMAGE OR PERSONAL INJURY DUE TO FIRE, USE ONLY COPPER CONDUCTORS.

CAUTION

TO PREVENT IMPROPER AND DANGEROUS OPERATION DUE TO WIRING ERRORS, LABEL ALL WIRES PRIOR TO DISCONNECTION WHEN SERVICING CONTROLS. VERIFY PROPER OPERATION AFTER SERVICING.

For unit protection, use a time delay fuse or HACR circuit breaker that is in excess of the circuit ampacity, but less than or equal to the maximum overcurrent protection device. **DO NOT EXCEED THE MAXIMUM OVERCURRENT DEVICE SIZE SHOWN ON UNIT DATA PLATE.**

All line voltage connections must be made through weatherproof fittings. All exterior power supply and ground wiring must be in approved weatherproof conduit. Low voltage wiring from the unit control panel to the thermostat requires coded cable. See below for ground level and rooftop wiring.

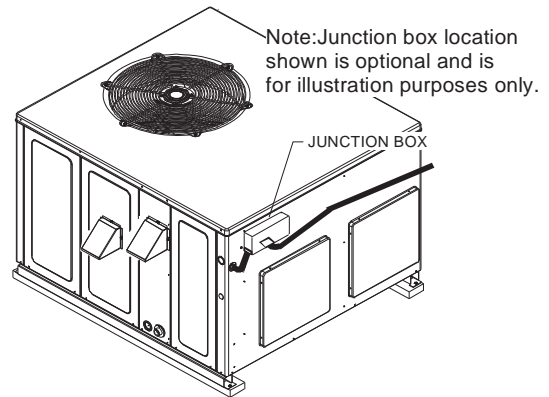

Electrical Power Directly To Junction Box

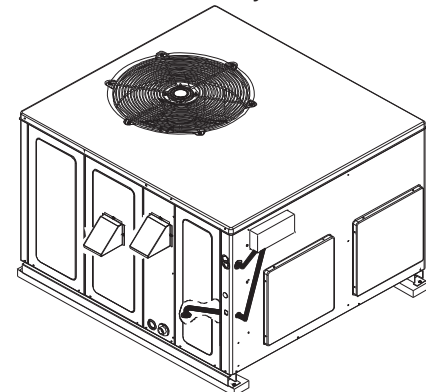

**Electrical Power Routed Through Bottom of Unit
 Typical Electrical Wiring Unit Voltage**

UNIT VOLTAGE

The unit transformer is factory connected for 230V operation. If the unit is to operate on 208V, reconnect the transformer primary lead as shown on the unit wiring diagram.

HEAT ANTICIPATOR SETTING

The heat anticipator is to be set by measuring the load (amperage) at the "R" circuit. Follow the instructions provided by the thermostat for more details.

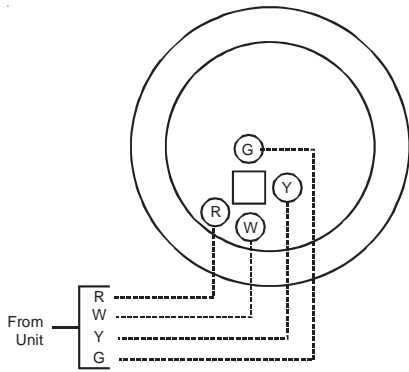

Typical Thermostat and Unit 24 V Wiring Hookup

CIRCULATING AIR AND FILTERS

AIRFLOW CONVERSION

Units can easily be converted from horizontal to down-discharge airflow delivery. In down-discharge or high static installations, the installer should measure the total external static and review the blower performance charts before performing the installation. In some installations it will be necessary to change the blower speed to provide proper air flow.

Horizontal Air Flow (Applies to 3 phase models)

Single phase models are shipped without horizontal duct covers. If needed, these kits may be ordered through Goodman's Service Parts department.

Remove supply and return duct covers which are attached to the unit as shown below.

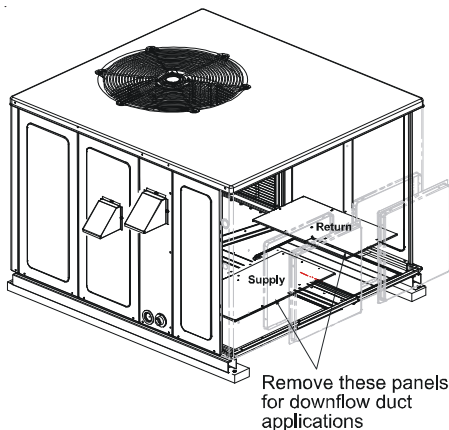
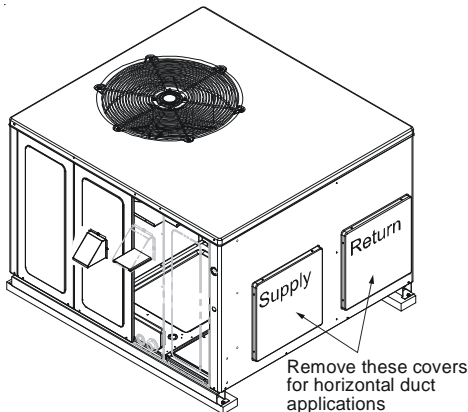

Duct Cover Installation

Down Discharge Applications

Cut insulation around bottom openings and remove panels from the bottom of the unit, saving the screws holding the panels in place.

NOTE: Single phase models require installation of horizontal duct kit #20464501PDGK (medium chassis) and #20464502PDGK (large chassis).

DUCTWORK

Duct systems and register sizes must be properly designed for the C.F.M. and external static pressure rating of the unit. Ductwork should be designed in accordance with the recommended methods of Air Conditioning Contractors of America Manual D (Residential) or Manual Q (Commercial). All ductwork exposed to the outdoors must include a weatherproof barrier and adequate insulation.

A duct system should be installed in accordance with Standards of the National Board of Fire Underwriters for the Installation of Air Conditioning, Warm Air Heating and Ventilating Systems. Pamphlets No. 90A and 90B.

The supply duct from the unit through a wall may be installed without clearance. However, minimum unit clearances as shown in the appendix must be maintained. The supply duct should be provided with an access panel large enough to inspect the air chamber downstream of the heat exchanger. A cover should be tightly attached to prevent air leaks.

For duct flange dimensions on the unit refer to the Unit Dimension illustration in the appendix.

For down-discharge applications, the ductwork should be attached to the roof curb prior to installing the unit. Ductwork dimensions are shown in the roof curb installation manual.

If desired, supply and return duct connections to the unit may be made with flexible connections to reduce possible unit operating sound transmission.

FILTERS



TO PREVENT PROPERTY DAMAGE DUE TO FIRE AND LOSS OF EQUIPMENT EFFICIENCY OR EQUIPMENT DAMAGE DUE TO DUST AND LINT BUILD UP ON INTERNAL PARTS, NEVER OPERATE UNIT WITHOUT AN AIR FILTER INSTALLED IN THE RETURN AIR SYSTEM.

Even though a return air filter is not supplied with this unit, there must be a means of filtering all return air. All units may be externally filtered.

Refer to the unit filter size chart in the appendix for filter size information.

Filters installed external to the unit should be sized in accordance with their manufacturer recommendations. A throwaway filter must be sized for a maximum face velocity of 300 feet per minute.

Filter Installation

Important: When installing a filter, the air flow arrows on the filter must point toward the circulator blower.

VENTING

NOTE: Venting is self-contained. Do not modify or block.

FLUE HOOD INSTALLATION

Install the exhaust flue hood and combustion air intake hood prior to operation of the unit.

To install the flue hood cover, please refer to IO-653*, included in the flue hood assembly box located in the blower compartment.

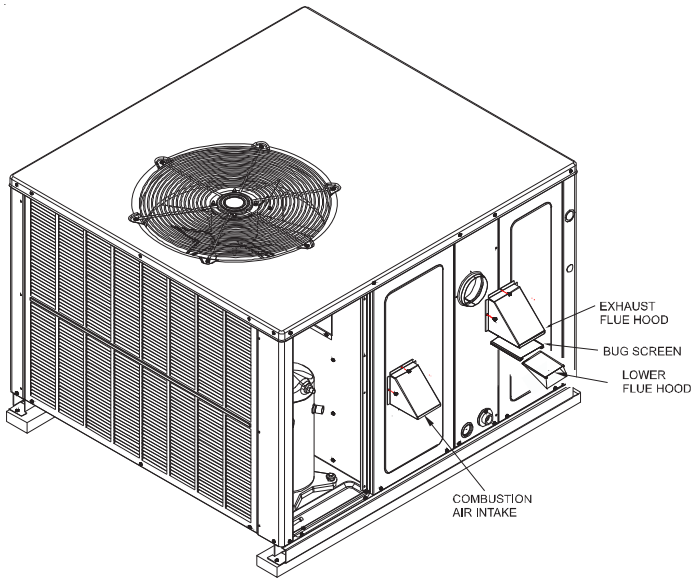

Flue Hood and Bug Screen Installation

CONDENSATE DRAIN

CONDENSATE DRAIN CONNECTION

A 3/4" NPT drain connection is supplied for condensate piping. An external trap must be installed for proper condensate drainage.

NOTE: Maximum torque is 10 in-lbs.

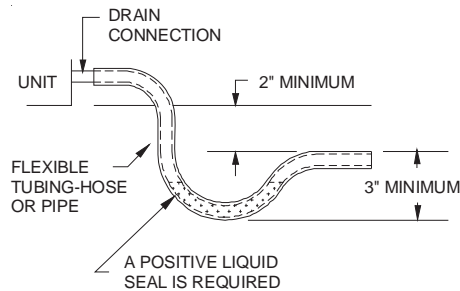

Drain Connection

NORMAL SEQUENCES OF OPERATION

HEATING

This unit is equipped with an ignition control that automatically lights the main burner. **DO NOT** attempt to light the main burners by any other method.

1. Thermostat calls for heat. The induced draft blower energizes for a 15-second pre-purge.

2. The spark igniter and gas valve energizes for 7 seconds. **NOTE:** The igniter produces a very intense electrical spark that ignites the gas.
3. The 30-second HEAT FAN ON delay time begins.
4. The unit delivers heat to the conditioned space until the thermostat is satisfied.
5. The gas valve deenergizes. The induced draft blower continues operation for a 29-second post-purge.
6. Ignition control begins timing the HEAT FAN OFF delay. There is an adjustable HEAT FAN OFF delay of approximately 120/135/150 seconds (factory set at 150). After the HEAT FAN OFF delay time has elapsed, the blower will deenergize. This allows any additional heat in the heat exchanger to be transferred to the conditioned space.

COOLING

1. Thermostat calls for cooling. The compressor and outdoor fan are energized.
2. Approximately seven seconds later, the indoor fan starts.
3. The unit will deliver cooling to the conditioned space until the thermostat is satisfied.
4. The compressor and outdoor fan will be de-energized when the thermostat opens.
5. The indoor fan continues to run for approximately 60 seconds after the thermostat is satisfied. This allows additional cooling from the indoor coil to be transferred to the conditioned space. Then, the indoor fan stops.

NOTE: A 180-second anti-short cycle is integral to the control and prevents recycling of the compressor.

FAN ONLY

1. Thermostat calls for FAN ONLY by energizing "G".
2. Approximately seven seconds later, the indoor fan starts.
3. The indoor fan continues to run for approximately 60 seconds after "G" is de-energized.

STARTUP, ADJUSTMENTS, AND CHECKS

HEATING STARTUP

This unit is equipped with an electronic ignition device to automatically light the main burners. It also has a power vent blower to exhaust combustion products.

On new installations, or if a major component has been replaced, the operation of the unit must be checked.

Check unit operation as outlined in the following instructions. If any sparking, odors, or unusual sounds are encountered, shut off electrical power and recheck for wiring errors, or obstructions in or near the blower motors. **Duct covers must be removed before operating unit.**

Heat Anticipator Setting

Set the heat anticipator on the room thermostat to 0.4 amps to obtain the proper number of heating cycles per hour and to prevent the room temperature from overshooting the room thermostat setting.

Rollout Protection Control

The rollout protection device opens, cutting power to the gas valve, if the flames from the burners are not properly drawn into the heat exchanger. The rollout protection device is located on the burner bracket. The reason for elevated temperatures at the control should be determined and repaired prior to resetting this manual reset control.

WARNING

TO AVOID PROPERTY DAMAGE, PERSONAL INJURY OR DEATH DUE TO FIRE OR EXPLOSION, A QUALIFIED SERVICER MUST INVESTIGATE THE REASON FOR THE ROLLOUT PROTECTION DEVICE TO OPEN BEFORE MANUALLY RESETTING THE ROLLOUT PROTECTION DEVICE.

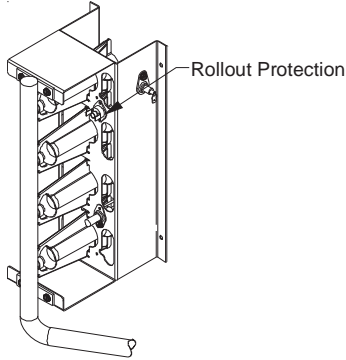

Rollout Protection on Burner Bracket

Secondary Limit Control

The secondary limit control is located on the top of the blower scroll assembly. This control opens when elevated temperatures are sensed. Elevated temperatures at the control are normally caused by blower failure. The reason for the opening should be determined and repaired prior to resetting.

If the power to the unit is interrupted during the heating cycle, it may cause the secondary limit to trip. Once the blower compartment temperature drops below the limit reset temperature, the limit will automatically reset.

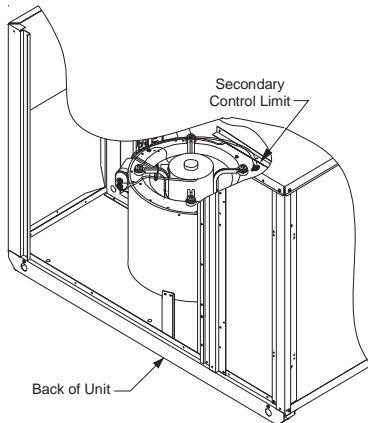

Secondary Limit Control

Pre-Operation Checks

1. Close the manual gas valve external to the unit.
2. Turn off the electrical power supply to the unit.
3. Set the room thermostat to its lowest possible setting.
4. Remove the heat exchanger door on the side of the unit by removing screws.
5. This unit is equipped with an ignition device which automatically lights the main burner. DO NOT try to light burner by any other method.
6. Move the gas control valve switch to the OFF position. Do not force.
7. Wait five minutes to clear out any gas.

8. Smell for gas, including near the ground. This is important because some types of gas are heavier than air. If you have waited five minutes and you do smell gas, immediately follow the warnings on page 3 of this manual. If having waited for five minutes and no gas smell is noted, move the gas control valve switch to the ON position.
9. Replace the heat exchanger door on the side of the unit.
10. Open the manual gas valve external to the unit.
11. Turn on the electrical power supply to the unit.
12. Set the thermostat to desired setting.

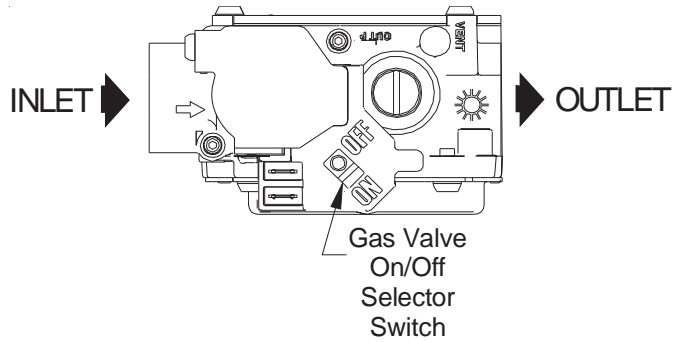

White-Rodgers 36G22

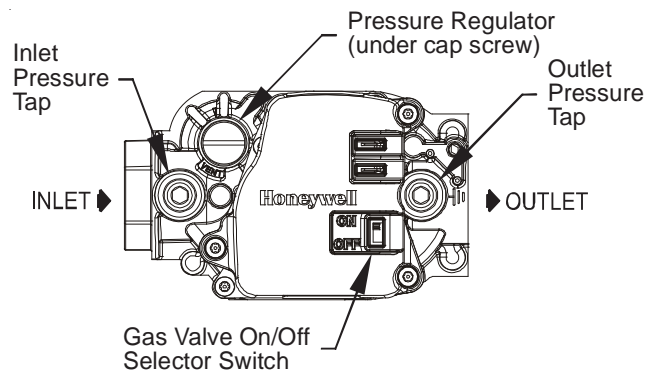

Honeywell Model VR8215 (Single-Stage)

Gas Supply And Manifold Check

Gas supply pressure and manifold pressure with the burners operating must be as specified on the rating plate.

GAS SUPPLY PRESSURE MEASUREMENT

CAUTION

TO PREVENT UNRELIABLE OPERATION OR EQUIPMENT DAMAGE, THE INLET GAS SUPPLY PRESSURE MUST BE AS SPECIFIED ON THE UNIT RATING PLATE WITH ALL OTHER HOUSEHOLD GAS FIRED APPLIANCES OPERATING.

WARNING

HIGH VOLTAGE
DISCONNECT ALL POWER BEFORE SERVICING OR INSTALLING THIS UNIT. MULTIPLE POWER SOURCES MAY BE PRESENT. FAILURE TO DO SO MAY CAUSE PROPERTY DAMAGE, PERSONAL INJURY OR DEATH.



The line pressure supplied to the gas valve must be within the range specified in the chart on the next page. The supply pressure can be measured at the gas valve inlet pressure tap or at a hose fitting installed in the gas piping drip leg. The supply pressure must be measured with the unit OFF. To measure inlet pressure, use the following procedure.

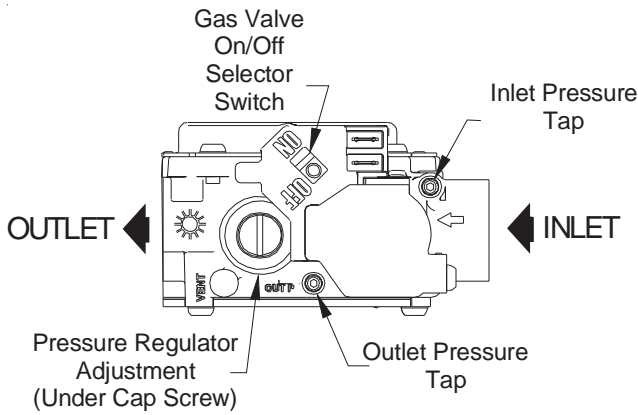

White-Rodgers Model 36G22

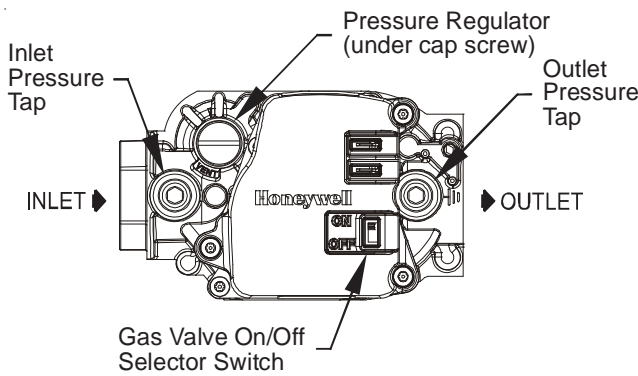

Honeywell Model VR8215 (Single-Stage)

1. Turn OFF gas to furnace at the manual gas shutoff valve external to the furnace.
2. Turn OFF all electrical power to the system.
3. Inlet pressure tap connections:
 - a. Honeywell VR8215 Valve:

Remove the inlet pressure boss plug. Install an 1/8" NPT hose barb fitting into the outlet pressure tap.
 - b. White-Rodgers 36G22 valve:

Back inlet pressure test screw (inlet pressure boss) out one turn (counterclockwise, not more than one turn).
4. Attach a hose and manometer to the outlet pressure barb fitting (Honeywell valve) or inlet pressure boss (White-Rodgers valve).
5. Turn ON the gas supply.
6. Turn On power and close thermostat "R" and "W" contacts to provide a call for heat.
7. Using a leak detection solution or soap suds, check for leaks at outlet pressure boss plug (Honeywell valve) or screw (White-Rodgers valve). Bubbles forming indicate a leak. **SHUT OFF GAS AND REPAIR ALL LEAKS IMMEDIATELY!**

8. Measure the gas supply pressure with burners firing. Adjust supply pressure using the *Inlet Gas Supply Pressure* table shown below. If supply pressure reading differs from the table, make necessary adjustments to pressure regulator, gas piping size, etc., and/or consult with local gas utility.

Inlet Gas Supply Pressure	
Natural Gas	Minimum:5.0" W.C. Maximum :10.0" W.C.
Propane Gas	Minimum:11.0" W.C. Maximum :13.0" W.C.

9. Turn OFF all electrical power and gas supply to the system.
10. Remove the manometer hose from the hose barb fitting or inlet pressure boss.
11. Replace inlet pressure tap:
 - a. Honeywell VR8215 valve:

Remove the 1/8" NPT hose barb fitting from the inlet pressure tap. Replace the inlet pressure boss plug and seal with a high quality thread sealer.
 - b. White-Rodgers 36G22 valve:

Turn inlet pressure test screw in to seal pressure port (clockwise, 7 in-lb minimum).
12. Retest for leaks. If bubbles form, **SHUT DOWN GAS AND REPAIR LEAKS IMMEDIATELY.**
13. Turn ON electrical power and gas supply to the system.
14. Turn valve switch ON.

GAS MANIFOLD PRESSURE MEASUREMENT AND ADJUSTMENT

CAUTION

TO PREVENT UNRELIABLE OPERATION OR EQUIPMENT DAMAGE, THE INLET GAS SUPPLY PRESSURE MUST BE AS SPECIFIED ON THE UNIT RATING PLATE WITH ALL OTHER HOUSEHOLD GAS FIRED APPLIANCES OPERATING.

WARNING

HIGH VOLTAGE
DISCONNECT ALL POWER BEFORE SERVICING OR INSTALLING THIS UNIT. MULTIPLE POWER SOURCES MAY BE PRESENT. FAILURE TO DO SO MAY CAUSE PROPERTY DAMAGE, PERSONAL INJURY OR DEATH.

This valve is shipped from the factory with the regulator preset (see control label).

Consult the appliance rating plate to ensure burner manifold pressure is as specified. If another outlet pressure is required, follow these steps.

1. Turn OFF gas to furnace at the manual gas shutoff valve external to the furnace.
2. Turn OFF all electrical power to the system.
3. Outlet pressure tap connections:
 - a. Honeywell VR8215 valve:

Remove the outlet pressure boss plug. Install an 1/8" NPT hose barb fitting into the outlet pressure tap.
 - b. White-Rodgers 36G22 valve:

Back outlet pressure test screw (outlet pressure boss) out one turn (counterclockwise, not more than one turn).
4. Attach a hose and manometer to the outlet pressure barb fitting (Honeywell valve) or outlet pressure boss (White-Rodgers valve).
5. Turn ON the gas supply.

6. Turn ON power and close thermostat "R" and "W" contacts to provide a call for heat.
7. Using a leak detection solution or soap suds, check for leaks at outlet pressure boss plug (Honeywell valve) or screw (White-Rodgers valve). Bubbles forming indicate a leak. SHUT OFF GAS AND REPAIR ALL LEAKS IMMEDIATELY!
8. Measure the gas manifold pressure with burners firing. Adjust manifold pressure using the *Manifold Gas Pressure* table shown below.

Manifold Gas Pressure	
Natural Gas	3.5" w.c.
Propane Gas	10.0" w.c.

9. Remove regulator cover screw from the outlet pressure regulator and turn screw clockwise to increase pressure or counterclockwise to decrease pressure. Replace regulator cover screw.
10. Turn OFF all electrical power and gas supply to the system.
11. Remove the manometer hose from the hose barb fitting or outlet pressure boss.
12. Replace outlet pressure tap:
 - a. Honeywell VR8215 valve: Remove the 1/8" NPT hose barb fitting from the outlet pressure tap. Replace the outlet pressure boss plug and seal with a high quality thread sealer.
 - b. White-Rodgers 36G22 valve: Turn outlet pressure test screw in to seal pressure port (clockwise, 7 in-lb minimum).
13. Turn ON electrical power and gas supply to the system.
14. Close thermostat contacts to provide a call for heat.
15. Retest for leaks. If bubbles form, SHUT OFF GAS AND REPAIR ALL LEAKS IMMEDIATELY!

Gas Input (Natural Gas Only) Check

To measure the gas input use a gas meter and proceed as follows:

1. Turn off gas supply to all other appliances except the unit.
2. With the unit operating, time the smallest dial on the meter for one complete revolution. If this is a 2 cubic foot dial, divide the seconds by 2; if it is a 1 cubic foot dial, use the seconds as is. This gives the seconds per cubic foot of gas being delivered to the unit.

3. INPUT=GAS HTG VALUE x 3600 / SEC. PER CUBIC FOOT

Example: Natural gas with a heating value of 1000 BTU per cubic foot and 34 seconds per cubic foot as determined by Step 2, then:

Input = 1000 x 3600 / 34 = 106,000 BTU per Hour. **NOTE:** BTU content of the gas should be obtained from the gas supplier. This measured input must not be greater than shown on the unit rating plate.

4. Relight all other appliances turned off in step 1. Be sure all pilot burners are operating.

Main Burner Flame Check

Flames should be stable, soft and blue (dust may cause orange tips but they must not be yellow) and extending directly outward from the burner without curling, floating or lifting off.

Temperature Rise Check

Check the temperature rise through the unit by placing thermometers in supply and return air registers as close to the unit as possible. Thermometers must not be able to sample temperature directly from the unit heat exchangers, or false readings could be obtained.

1. All registers must be open; all duct dampers must be in their final (fully or partially open) position and the unit operated for 15 minutes before taking readings.
2. The temperature rise must be within the range specified on the rating plate.

NOTE: Air temperature rise is the temperature difference between supply and return air.

With a properly designed system, the proper amount of temperature rise will normally be obtained when the unit is operated at rated input with the recommended blower speed. If the correct amount of temperature rise is not obtained, it may be necessary to change the blower speed. A higher blower speed will lower the temperature rise. A slower blower speed will increase the temperature rise.

NOTE: Blower speed MUST be set to give the correct air temperature rise through the unit as marked on the rating plate.

External Static Pressure Check

The total external static pressure must be checked on this unit to determine if the airflow is proper.

Blower Speed Adjustments

!	WARNING
TO AVOID PERSONAL INJURY OR DEATH DUE TO ELECTRIC SHOCK, REMOVE ELECTRICAL POWER FROM THE UNIT BEFORE CHANGING SPEED TAPS ON THE BLOWER MOTOR.	

Refer to the wiring diagram in the appendix to verify speed tap settings.

For models equipped with PSC type motors, blower speeds are to be changed at the ignition control board. Both heat speed and cool speed terminals are supplied on the board along with two unused motor lead terminals.

Some models are equipped with EEM motors. EEM motors are constant torque motors with very low power consumption. This motor is energized by 24V. Adjust the CFM for the unit by changing the 24V low voltage leads to the speed terminal block on the motor.

Heating-White Lead	Cooling-Yellow Lead
T1 - Low Speed	T4 - Low Speed
T2 - Medium Speed	T5 - High Speed
T3 - High Speed	

NOTE: Heating airflow must be adjusted to provide the temperature rise shown on rating plate.

Limit Check

Check limit control operation after 15 minutes of operation by blocking the return air grille(s).

1. After several minutes the main burners must go OFF. Blower will continue to run.
2. Remove air restrictions and main burners will relight after a cool down period of a few minutes.

Adjust the thermostat setting below room temperature.

1. Main burners must go OFF.
2. Circulating Air Blower will continue to run for 120, 135 or 150 seconds, depending on the setting.

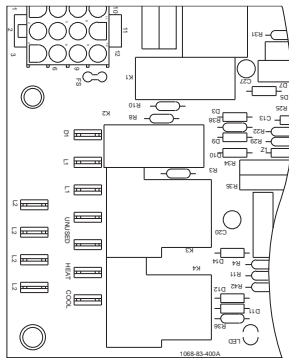

Control Board (Top)

NOTE: If necessary, adjust fan OFF delay settings to obtain satisfactory comfort level.

WARNING

THIS UNIT MUST NOT BE USED AS A "CONSTRUCTION HEATER" DURING THE FINISHING PHASES OF CONSTRUCTION ON A NEW STRUCTURE. THIS TYPE OF USE MAY RESULT IN PREMATURE FAILURE OF THE UNIT DUE TO EXTREMELY LOW RETURN AIR TEMPERATURES AND EXPOSURE TO CORROSIVE OR VERY DIRTY ATMOSPHERES.

Unit Shutdown

1. Set the thermostat to lowest setting.
2. Turn off the electrical power supply to the unit.
3. Remove the heat exchanger door on the side of the unit by removing screws.
4. Move the gas control valve switch to the OFF position. Do not force.
5. Close manual gas shutoff valve external to the unit.
6. Replace the heat exchanger door on the unit.
7. If cooling and/or air circulation will be desired, turn ON the electrical power.

COOLING STARTUP

NOTE: Check all manual reset limit controls in heating circuit if cooling mode does not operate.

Compressor Protection Devices

The compressor includes components which are designed to protect the compressor against abnormal operating conditions.

WARNING

TO PREVENT PERSONAL INJURY OR DEATH, ALWAYS DISCONNECT ELECTRICAL POWER BEFORE INSPECTING OR SERVICING THE UNIT. ALL COMPRESSOR PROTECTION DEVICES RESET AUTOMATICALLY, ENERGIZING THE CONTACTOR AND OUTDOOR FAN.

Refrigerant Charge Check

After completing airflow measurements and adjustments the unit's refrigerant charge must be checked. The unit comes factory charged, but this charge is based on 325 CFM per ton and minimum ESP per AHRI test conditions (generally between .15 -.28 ESP). When air quantity or ESP is different than above, the refrigerant charge must be adjusted to the proper amount.

All package units with fixed orifice devices are charged using the super heat method at the compressor suction line.

After superheat is adjusted it is recommended to check unit sub-cooling at the condenser coil liquid line out. For charge adjustments, see superheat and sub-cooling charts shown for each model.

Design superheat & subcooling @ 95 °F outdoor		
Models #	Superheat ± 2°F	Subcooling ± 3°F
GPG1324***M	7	15
GPG1330***M	6	15
GPG1336***M	7	9
GPG1342***M	9	12
GPG1348***M	13	9
GPG1360***M	10	9

Cooling Operation

NOTE: Mechanical cooling cannot be reliably provided at ambient temperatures below 50° F.

1. Turn on the electrical power supply to the unit.
2. Place the room thermostat selector switch in the COOL position (or AUTO if available, and if automatic changeover from cooling to heating is desired).
3. Set the room thermostat to the desired temperature.

TROUBLESHOOTING

IGNITION CONTROL ERROR CODES

The following presents probable causes of questionable unit operation. Refer to *Diagnostic Indicator Chart* for an interpretation of the signal and to this section for an explanation.

Remove the control box access panel and note the number of diagnostic LED flashes. Refer to *Diagnostic Indicator Chart* for an interpretation of the signal and to this section for an explanation.

ABNORMAL OPERATION - HEATING

Internal Control Failure

If the integrated ignition control in this unit encounters an internal fault, it will go into a "hard" lockout and turn off the diagnostic LED. If diagnostic LED indicates an internal fault, check power supply to unit for proper voltage, check all fuses, circuit breakers and wiring. Disconnect electric power for five seconds. If LED remains off after restoring power, replace control.

External Lockout

An external lockout occurs if the integrated ignition control determines that a measurable combustion cannot be established within three (3) consecutive ignition attempts. If flame is not established within the seven (7) second trial for ignition, the gas valve is de-energized, 15 second inter-purge cycle is completed, and ignition is reattempted. The control will repeat this routine three times if a measurable combustion is not established. The control will then shut off the induced draft blower and go into a lockout state.

If flame is established but lost, the control will energize the circulator blower at the heat speed and then begin a new ignition sequence. If flame is established then lost on subsequent attempts, the control will recycle for four (4) consecutive ignition attempts (five attempts total) before locking out.

The diagnostic fault code is 1 flash for a lockout due to failed ignition attempts or flame dropouts. The integrated control will automatically reset after one hour, or it can be reset by removing the thermostat signal or disconnecting the electrical power supply for over five seconds. If the diagnostic LED indicates an external lockout, perform the following checks:

- *Check the supply and manifold pressures*
- *Check the gas orifices for debris*
- *Check gas valve for proper operation*
- *Check secondary limit*

A dirty filter, excessive duct static, insufficient air flow, a faulty limit, or a failed circulator blower can cause this limit to open. Check filters, total external duct static, circulator blower motor, blower motor speed tap (see wiring diagram), and limit. An interruption in electrical power during a heating cycle may also cause the auxiliary limit to open. The automatic reset secondary limit is located on top of the circulator blower assembly.

- *Check rollout limit*

If the burner flames are not properly drawn into the heat exchanger, the flame rollout protection device will open. Possible causes are restricted or blocked flue passages, blocked or cracked heat exchanger, a failed induced draft blower, or insufficient combustion air. The rollout protection device is a manual reset limit located on the burner bracket. The cause of the flame rollout must be determined and corrected before resetting the limit.

- *Check flame sensor*

A drop in flame signal can be caused by nearly invisible coating on the sensor. Remove the sensor and carefully clean with steel wool.

- *Check wiring*

Check wiring for opens/shorts and miswiring.

Important: If you have to frequently reset your gas/electric package unit, it means that a problem exists that should be corrected. Contact a qualified servicer for further information.

Pressure Switch Stuck Open

A pressure switch stuck open can be caused by a faulty pressure switch, faulty wiring, a disconnected or damaged hose, a blocked or restricted flue, or a faulty induced draft blower.

If the control senses an open pressure switch during the pre-purge cycle, the induced draft blower only will be energized. If the pressure switch opens after ignition has begun the gas valve is de-energized, the circulator blower heat off cycle begins, and the induced draft blower remains on. The diagnostic fault code is two flashes.

Pressure Switch Stuck Closed

A stuck closed pressure switch can be caused by a faulty pressure switch or faulty wiring. If the control encounters a pressure switch stuck closed, the induced draft blower remains off. The diagnostic LED code for this fault is three (3) flashes.

Open Thermal Protection Device

If the primary limit switch opens, the gas valve is immediately de-energized, the induced draft and air circulating blowers are energized. The induced draft and air circulator blowers remain energized until the limit switch recloses. The diagnostic fault code for an open limit is four (4) flashes.

A primary limit will open due to excessive supply air temperatures. This can be caused by a dirty filter, excessive duct static, insufficient air flow, or a faulty limit. Check filters, total external duct static, blower motor, blower motor speed tap (see wiring diagram), and limit. This limit will automatically reset once the temperature falls below a preset level.

Flame Detected with Gas Valve Closed

If flame is detected with the gas valve de-energized, the combustion and air circulator blowers are energized. The diagnostic fault code is five (5) flashes for this condition. The control can be reset by removing the power supply to the unit or it will automatically reset after one hour. Miswiring is the probable cause for this fault.

ABNORMAL OPERATION - COOLING

Short Cycle Compressor Delay

The automatic ignition control has a built-in feature that prevents damage to the compressor in short cycling situations. In the event of intermittent power losses or intermittent thermostat operation, the ignition control will delay output to the compressor contactor for three minutes from the time power is restored. (Compressor is off a total of three minutes). The diagnostic LED will flash six (6) times to indicate the compressor contactor output is being delayed.

NOTE: Some electronic thermostats also have a built-in compressor short cycle timer that may be longer than the three minute delay given above. If you are using an electronic thermostat and the compressor has not started after three minutes, wait an additional five minutes to allow the thermostat to complete its short cycle delay time.

MAINTENANCE

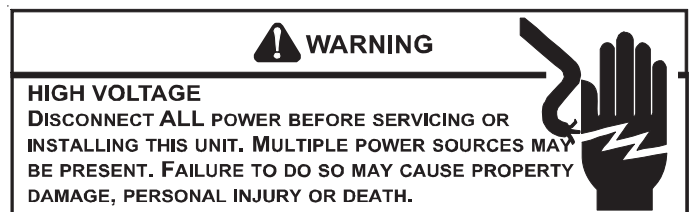

Have the gas heating section of the unit checked at least once a year before the heating season begins, to be sure that the combustion air inlet and flue outlet hoods are not blocked by debris, which would prevent adequate combustion air and a properly operating vent system.

FILTER REPLACEMENT OR CLEANING

A return air filter is not supplied with this unit; however, there must be a means of filtering all of the return air. The filter(s) may be located in the return air duct(s), or return air filter grille(s). Consult with your installing dealer for the actual location of the return air filter(s) for your unit.

Dirty filters are the most common cause of inadequate heating or cooling performance. Filter inspection should be made at least every two months; more often if necessary because of local conditions and usage.

Dirty throwaway filters should be discarded and replaced with a new, clean filter. Dirty permanent filters should be washed with water, thoroughly dried and sprayed with a filter adhesive before being reinstalled. (Filter adhesives may be found at many hardware stores.) Permanent filters should last several years. However, should one become torn or uncleanable, it should be replaced.

CABINET FINISH MAINTENANCE

Use a fine grade automotive wax on the cabinet finish to maintain the finish's original high luster. This is especially important in installations with extended periods of direct sunlight.

CLEAN OUTSIDE COIL (QUALIFIED SERVICER ONLY)

The coil with the outside air flowing over it should be inspected annually and cleaned as frequently as necessary to keep the finned areas free of lint, hair and debris.

CONDENSER, EVAPORATOR, AND INDUCED DRAFT MOTORS

Bearings on the air circulating blower motor, condenser motor and the combustion fan motor are permanently lubricated. No additional oiling is required.

FLAME SENSOR (QUALIFIED SERVICER ONLY)

A drop in the flame current can be caused by a nearly invisible coating on the flame sensor. This coating, created by the fuel or combustion air supply, can be removed by carefully cleaning the flame sensor with steel wool.

NOTE: After cleaning, the microamp signal should be stable and in the range of 4 - 6 microamps DC.

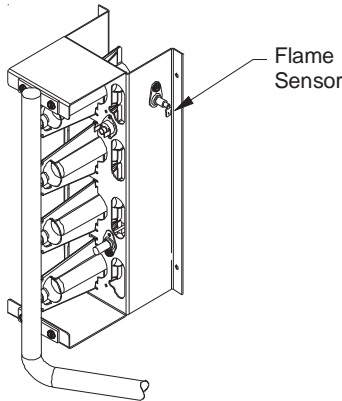

Flame Sensor

FLUE PASSAGES (QUALIFIED SERVICER ONLY)

At the start of each heating season, inspect and, if necessary, clean the unit flue passage.

CLEANING FLUE PASSAGES (QUALIFIED SERVICER ONLY)

1. Shut off electric power and gas supply to the unit.
2. Remove burner assembly by disconnecting the gas line and removing the manifold bracket from the partition panel.
3. Remove the flue from the induced draft blower and the collector box cover from the partition panel.
4. The primary heat exchanger tubes can be cleaned using a round wire brush attached to a length of high grade stainless steel cable, such as drain cleanout cable. Attach a variable speed reversible drill to the other end of the spring cable. Slowly rotate the cable with the drill and insert it into one of the primary heat exchanger tubes. While reversing the drill, work the cable in and out several times to obtain sufficient cleaning. Use a large cable for the large tube, and then repeat the operation with a small cable for the smaller tube. Repeat for each tube.
5. When all heat exchanger tubes have been cleaned, replace the parts in the reverse order in which they were removed.
6. To reduce the chances of repeated fouling of the heat exchanger, perform the steps listed in "Startup, Adjustments, and Checks".

MAIN BURNER FLAME (QUALIFIED SERVICER ONLY)

Flames should be stable, soft and blue (dust may cause orange tips but must not be yellow). The flames must extend directly outward from the burner without curling, floating or lifting off.

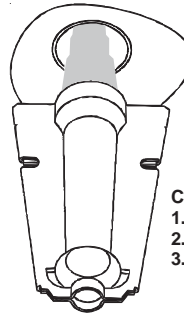

- Check the burner flames for:
1. Good adjustment
 2. Stable, soft and blue
 3. Not curling, floating, or lifting off.

Burner Flame

WARNING

TO AVOID PERSONAL INJURY OR DEATH DUE TO ELECTRIC SHOCK, DO NOT REMOVE ANY INTERNAL COMPARTMENT COVERS OR ATTEMPT ANY ADJUSTMENT. CONTACT A QUALIFIED SERVICER AT ONCE IF AN ABNORMAL FLAME SHOULD DEVELOP.

At least once a year, prior to or during the heating season, make a visual check of the burner flames.

NOTE: This will involve removing and reinstalling the heat exchanger door on the unit, which is held by two screws. If you are uncertain about your ability to do this, contact a qualified servicer. If a strong wind is blowing, it may alter the airflow pattern within the unit enough that an inspection of the burner flames is not possible.

CLEANING BURNERS

1. Shut off electric power and gas supply to the unit.
2. Remove the screws securing the manifold to the burner retention bracket. Remove the manifold and rotate each burner counterclockwise to remove.

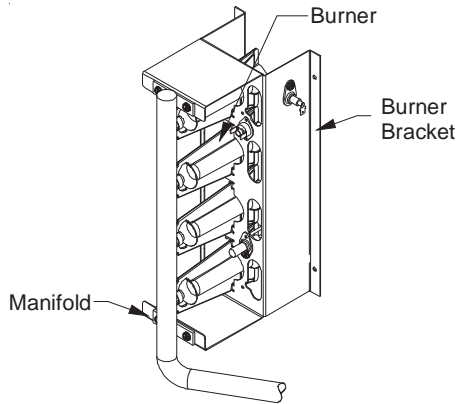

Manifold Assembly

3. Remove the burners.
4. Use a bottle brush to clean burner insert and inside of the burners.
5. Replace burners and manifold, inspect the burner assembly for proper seating of burners in retention slots.
6. Reconnect electrical power and gas supply.

CAUTION

LABEL ALL WIRES PRIOR TO DISCONNECTION WHEN SERVICING CONTROLS.
WIRING ERRORS CAN CAUSE IMPROPER AND DANGEROUS OPERATION.

CAUTION

ALWAYS VERIFY PROPER OPERATION AFTER SERVICING.

For further information on the yearly inspection, consult the User Manual. It is recommended that a qualified servicer inspect and service the unit at least once each year.

Turn the unit on at the thermostat. Wait a few minutes, since any dislodged dust will alter the normal flame appearance. Flames should be predominantly blue and directed into the tubes. They should not be yellow. They should extend directly outward from the burner ports without curling downward, floating or lifting off the ports.

ACCESSORIES AND FUNCTIONAL PARTS

SHEET METAL ACCESSORIES

Additional accessories can be purchased to fit specific application needs. Parts and instructions are available from your distributor.

FUNCTIONAL PARTS

FUNCTIONAL PARTS	
Auxiliary Limit Switch	Flame Roll-out Switch
Blower Housing	Flame Sensor
Circulator Blower Motor	Gas Orifice
Blower Wheel	Gas Valve
Burner	Heat Exchanger
Capacitor	High Limit Switch
Compressor	Igniter
Condenser Coil	Ignition Control
Condenser Fan Blade	Induced Draft Blower
Condenser Fan Motor	Pressure Switch
Contactors	Pressure Switch Hose
Gas Manifold	Transformer
Evaporator Coil	

Functional Parts List

GENERAL INFORMATION

1. Refer to the description in Functional Parts List when ordering any of the listed functional parts. Be sure to provide the unit model and serial numbers with the order.
2. Although only functional parts are shown, all sheet metal parts, doors, etc. may be ordered by description.
3. Parts are available from your distributor.

BLOWER PERFORMANCE DATA - SINGLE PHASE

*PG1324045M41** - Rise Range: 30° - 60°									
Unit Static	LOW			MEDIUM			HIGH		
	CFM	WATTS	RISE	CFM	WATTS	RISE	CFM	WATTS	RISE
0.1	600	150	57	850	230	40	1,190	380	X
0.2	570	140	60	830	220	41	1,140	360	X
0.3	510	130	X	765	215	45	1,080	350	32
0.4	450	125	X	715	210	48	1,025	340	33
0.5	380	120	X	660	205	52	975	330	35
0.6	-----	-----	X	610	195	56	920	310	37
0.7	-----	-----	X	-----	-----	X	830	300	41
0.8	-----	-----	X	-----	-----	X	730	290	47

*PG1324070M41** - Rise Range: 35° - 65°									
Unit Static	LOW			MEDIUM			HIGH		
	CFM	WATTS	RISE	CFM	WATTS	RISE	CFM	WATTS	RISE
0.1	600	150	X	850	230	X	1,190	380	43
0.2	570	140	X	830	220	X	1,140	360	45
0.3	510	130	X	765	215	X	1,080	350	47
0.4	450	125	X	715	210	X	1,025	340	50
0.5	380	120	X	660	205	X	975	330	52
0.6	-----	-----	X	610	195	X	920	310	56
0.7	-----	-----	X	-----	-----	X	830	300	62
0.8	-----	-----	X	-----	-----	X	730	290	X

*PG1330045M41** - Rise Range: 30° - 60°									
Unit Static	LOW			MEDIUM			HIGH		
	CFM	WATTS	RISE	CFM	WATTS	RISE	CFM	WATTS	RISE
0.1	1,056	350	33	1,261	452	X	1,370	509	X
0.2	1,010	339	34	1,221	442	X	1,310	492	X
0.3	971	343	36	1,174	428	X	1,262	489	X
0.4	937	329	37	1,125	414	31	1,208	475	X
0.5	878	318	39	1,063	398	32	1,140	453	30
0.6	811	306	43	1,004	380	34	1,081	440	32
0.7	723	291	48	919	368	38	1,006	425	34
0.8	545	259	X	796	371	43	879	403	39

*PG133070M41** - Rise Range: 35° - 65°									
Unit Static	LOW			MEDIUM			HIGH		
	CFM	WATTS	RISE	CFM	WATTS	RISE	CFM	WATTS	RISE
0.1	1,056	350	49	1,261	452	41	1,370	509	38
0.2	1,010	339	51	1,221	442	42	1,310	492	40
0.3	971	343	53	1,174	428	44	1,262	489	41
0.4	937	329	55	1,125	414	46	1,208	475	43
0.5	878	318	59	1,063	398	49	1,140	453	45
0.6	811	306	64	1,004	380	52	1,081	440	48
0.7	723	291	X	919	368	56	1,006	425	X
0.8	545	259	X	796	371	65	879	403	X

X= Heating Temperature Rise Not Recommended.

NOTE: The shaded area indicates ranges in excess of maximum external static pressure allowable when heating. For satisfactory operation, external static pressure should not exceed 0.5" w.c.

BLOWER PERFORMANCE DATA - SINGLE PHASE

*PG1336045M41** - Rise Range: 30 -60°									
Unit Static	LOW			MEDIUM			HIGH		
	CFM	WATTS	RISE	CFM	WATTS	RISE	CFM	WATTS	RISE
0.1	1,029	346	34	1,337	471	X	1,462	596	X
0.2	982	334	35	1,265	452	X	1,398	563	X
0.3	946	329	36	1,227	448	X	1,326	550	X
0.4	888	313	39	1,159	429	30	1,260	534	X
0.5	823	304	42	1,073	405	32	1,188	513	X
0.6	750	287	46	1,008	393	34	1,090	496	32
0.7	668	271	52	895	371	39	997	478	35
0.8	454	238	X	760	346	45	852	454	40

*PG1336070M41** - Rise Range: 35° -65°									
Unit Static	LOW			MEDIUM			HIGH		
	CFM	WATTS	RISE	CFM	WATTS	RISE	CFM	WATTS	RISE
0.1	1,029	346	50	1,337	471	39	1,462	596	35
0.2	982	334	53	1,265	452	41	1,398	563	37
0.3	946	329	55	1,227	448	42	1,326	550	39
0.4	888	313	58	1,159	429	45	1,260	534	41
0.5	823	304	63	1,073	405	48	1,188	513	44
0.6	750	287	X	1,008	393	51	1,090	496	47
0.7	668	271	X	895	371	58	997	478	52
0.8	454	238	X	760	346	68	852	454	61

*PG1336090M41** - Rise Range: 45° -75°									
Unit Static	LOW			MEDIUM			HIGH		
	CFM	WATTS	RISE	CFM	WATTS	RISE	CFM	WATTS	RISE
0.1	1,029	346	50	1,337	471	X	1,462	596	X
0.2	982	334	53	1,265	452	X	1,398	563	X
0.3	946	329	55	1,227	448	X	1,326	550	X
0.4	888	313	58	1,159	429	45	1,260	534	X
0.5	823	304	63	1,073	405	48	1,188	513	X
0.6	750	287	69	1,008	393	51	1,090	496	47
0.7	668	271	X	895	371	58	997	478	52
0.8	454	238	X	760	346	68	852	454	61

*PG1342070M41** - Rise Range: 35° - 65°									
Unit Static	LOW			MEDIUM			HIGH		
	CFM	WATTS	RISE	CFM	WATTS	RISE	CFM	WATTS	RISE
0.1	1,100	340	46	1,450	480	35	1,575	585	X
0.2	1,040	325	49	1,390	460	37	1,515	565	X
0.3	1,000	320	51	1,300	445	39	1,430	550	36
0.4	925	305	55	1,215	425	42	1,340	525	38
0.5	860	290	59	1,115	395	46	1,240	505	41
0.6	800	275	64	1,030	375	50	1,130	465	45
0.7	690	255	X	945	350	54	1,010	450	51
0.8	-----	-----	X	860	335	59	910	430	56

*PG1342090M41** - Rise Range: 45° - 75°									
Unit Static	LOW			MEDIUM			HIGH		
	CFM	WATTS	RISE	CFM	WATTS	RISE	CFM	WATTS	RISE
0.1	1,100	340	62	1,450	480	47	1,575	585	X
0.2	1,040	325	66	1,390	460	49	1,515	565	45
0.3	1,000	320	68	1,300	445	52	1,430	550	48
0.4	925	305	74	1,215	425	56	1,340	525	51
0.5	860	290	X	1,115	395	61	1,240	505	55
0.6	800	275	X	1,030	375	66	1,130	465	60
0.7	690	255	X	945	350	72	1,010	450	67
0.8	-----	-----	X	860	335	X	910	430	75

X = Heating Temperature Rise Not Recommended.

NOTE: The shaded area indicates ranges in excess of maximum external static pressure allowable when heating. For satisfactory operation, external static pressure should not exceed 0.5" w.c.

BLOWER PERFORMANCE DATA - SINGLE PHASE

*PG1348070M41** - Rise Range: 35° - 65° F													
E.S.P	T1 HEATING SPEED			T2 HEATING SPEED			T3 HEATING SPEED			T4 COOLING SPEED		T5 COOLING SPEED	
	CFM	WATTS	RISE	CFM	WATTS	RISE	CFM	WATTS	RISE	CFM	WATTS	CFM	WATTS
0.1	---	---	---	---	---	---	---	---	---	---	---	---	---
0.2	892	104	56	1088	183	46	1401	310	X	1624	400	1704	433
0.3	824	112	62	1024	191	50	1345	318	X	1573	408	1655	440
0.4	756	120	69	960	199	53	1289	326	X	1522	416	1606	448
0.5	687	128	X	897	207	58	1233	333	X	1472	424	1558	456
0.6	619	135	X	833	214	62	1176	341	X	1421	431	1509	464
0.7	551	143	X	770	222	66	1120	349	45	1370	439	1460	472
0.8	482	151	X	706	230	73	1064	357	48	1319	447	1411	480

*PG1348090M41** - Rise Range: 45° - 75° F													
E.S.P	T1 HEATING SPEED			T2 HEATING SPEED			T3 HEATING SPEED			T4 COOLING SPEED		T5 COOLING SPEED	
	CFM	WATTS	RISE	CFM	WATTS	RISE	CFM	WATTS	RISE	CFM	WATTS	CFM	WATTS
0.1	---	---	---	---	---	---	---	---	---	---	---	---	---
0.2	892	104	75	1088	183	62	1401	310	49	1624	400	1704	433
0.3	824	112	X	1024	191	67	1345	318	51	1573	408	1655	440
0.4	756	120	X	960	199	71	1289	326	53	1522	416	1606	448
0.5	687	128	X	897	207	X	1233	333	54	1472	424	1558	456
0.6	619	135	X	833	214	X	1176	341	58	1421	431	1509	464
0.7	551	143	X	770	222	X	1120	349	61	1370	439	1460	472
0.8	482	151	X	706	230	X	1064	357	65	1319	447	1411	480

*PG1348115M41** - Rise Range: 45° - 75° F													
E.S.P	T1 HEATING SPEED			T2 HEATING SPEED			T3 HEATING SPEED			T4 COOLING SPEED		T5 COOLING SPEED	
	CFM	WATTS	RISE	CFM	WATTS	RISE	CFM	WATTS	RISE	CFM	WATTS	CFM	WATTS
0.1	---	---	---	---	---	---	---	---	---	---	---	---	---
0.2	892	104	X	1088	183	77	1401	310	61	1624	400	1704	433
0.3	824	112	X	1024	191	X	1345	318	63	1573	408	1655	440
0.4	756	120	X	960	199	X	1289	326	66	1522	416	1606	448
0.5	687	128	X	897	207	X	1233	333	67	1472	424	1558	456
0.6	619	135	X	833	214	X	1176	341	72	1421	431	1509	464
0.7	551	143	X	770	222	X	1120	349	X	1370	439	1460	472
0.8	482	151	X	706	230	X	1064	357	X	1319	447	1411	480

*PG1360090M41** - Rise Range: 45° - 75° F													
E.S.P	T1 HEATING SPEED			T2 HEATING SPEED			T3 HEATING SPEED			T4 COOLING SPEED		T5 COOLING SPEED	
	CFM	WATTS	RISE	CFM	WATTS	RISE	CFM	WATTS	RISE	CFM	WATTS	CFM	WATTS
0.1	1100	97	61	1445	305	47	1762	496	X	1878	566	2080	688
0.2	1050	105	65	1396	313	50	1713	504	X	1829	574	2031	696
0.3	1001	113	69	1346	321	51	1664	512	X	1780	582	1982	704
0.4	952	121	75	1297	329	53	1615	521	X	1730	590	1932	712
0.5	903	129	X	1248	337	55	1566	529	X	1681	598	1883	720
0.6	854	137	X	1199	345	58	1516	537	45	1632	607	1834	728
0.7	804	145	X	1149	353	60	1467	545	46	1583	615	1785	736
0.8	755	153	X	1100	361	63	1418	553	48	1534	623	1736	745

X = Heating Temperature Rise Not Recommended.

NOTE: The shaded area indicates ranges in excess of maximum external static pressure allowable when heating. For satisfactory operation, external static pressure should not exceed 0.5" w.c.

BLOWER PERFORMANCE DATA - SINGLE PHASE

*PG1360140M41** - Rise Range: 45° - 75° F													
E.S.P	T1 HEATING SPEED			T2 HEATING SPEED			T3 HEATING SPEED			T4 COOLING SPEED		T5 COOLING SPEED	
	CFM	WATTS	RISE	CFM	WATTS	RISE	CFM	WATTS	RISE	CFM	WATTS	CFM	WATTS
0	1100	97	X	1445	305	71	1762	496	59	1878	566	2080	688
0.2	1050	105	X	1396	313	X	1713	504	60	1829	574	2031	696
0.3	1001	113	X	1346	321	X	1664	512	63	1780	582	1982	704
0.4	952	121	X	1297	329	X	1615	521	65	1730	590	1932	712
0.5	903	129	X	1248	337	X	1566	529	67	1681	598	1883	720
0.6	854	137	X	1199	345	X	1516	537	69	1632	607	1834	728
0.7	804	145	X	1149	353	X	1467	545	71	1583	615	1785	736
0.8	755	153	X	1100	361	X	1418	553	74	1534	623	1736	745

GPG1348090M43B* - Rise Range: 45° - 75° F													
E.S.P	T1 HEATING SPEED			T2 HEATING SPEED			T3 HEATING SPEED			T4 COOLING SPEED		T5 COOLING SPEED	
	CFM	WATTS	RISE	CFM	WATTS	RISE	CFM	WATTS	RISE	CFM	WATTS	CFM	WATTS
0.1	---	---	---	---	---	---	---	---	---	---	---	---	---
0.2	892	104	75	1088	183	62	1401	310	49	1624	400	1704	433
0.3	824	112	X	1024	191	67	1345	318	51	1573	408	1655	440
0.4	756	120	X	960	199	71	1289	326	53	1522	416	1606	448
0.5	687	128	X	897	207	X	1233	333	54	1472	424	1558	456
0.6	619	135	X	833	214	X	1176	341	58	1421	431	1509	464
0.7	551	143	X	770	222	X	1120	349	61	1370	439	1460	472
0.8	482	151	X	706	230	X	1064	357	65	1319	447	1411	480

GPG1360090M43B* - Rise Range: 45° - 75° F													
E.S.P	T1 HEATING SPEED			T2 HEATING SPEED			T3 HEATING SPEED			T4 COOLING SPEED		T5 COOLING SPEED	
	CFM	WATTS	RISE	CFM	WATTS	RISE	CFM	WATTS	RISE	CFM	WATTS	CFM	WATTS
0	1100	97	61	1445	305	47	1762	496	X	1878	566	2080	688
0.2	1050	105	65	1396	313	50	1713	504	X	1829	574	2031	696
0.3	1001	113	69	1346	321	51	1664	512	X	1780	582	1982	704
0.4	952	121	75	1297	329	53	1615	521	X	1730	590	1932	712
0.5	903	129	80	1248	337	55	1566	529	X	1681	598	1883	720
0.6	854	137	85	1199	345	58	1516	537	45	1632	607	1834	728
0.7	804	145	93	1149	353	60	1467	545	46	1583	615	1785	736
0.8	755	153	97	1100	361	63	1418	553	48	1534	623	1736	745

GPG1360140M43B* - Rise Range: 45° - 75° F													
E.S.P	T1 HEATING SPEED			T2 HEATING SPEED			T3 HEATING SPEED			T4 COOLING SPEED		T5 COOLING SPEED	
	CFM	WATTS	RISE	CFM	WATTS	RISE	CFM	WATTS	RISE	CFM	WATTS	CFM	WATTS
0	1100	97	X	1445	305	X	1762	496	59	1878	566	2080	688
0.2	1050	105	X	1396	313	X	1713	504	60	1829	574	2031	696
0.3	1001	113	X	1346	321	X	1664	512	63	1780	582	1982	704
0.4	952	121	X	1297	329	X	1615	521	65	1730	590	1932	712
0.5	903	129	X	1248	337	X	1566	529	67	1681	598	1883	720
0.6	854	137	X	1199	345	X	1516	537	69	1632	607	1834	728
0.7	804	145	X	1149	353	X	1467	545	71	1583	615	1785	736
0.8	755	153	X	1100	361	X	1418	553	72	1534	623	1736	745

X = Heating Temperature Rise Not Recommended.

NOTE: The shaded area indicates ranges in excess of maximum external static pressure allowable when heating. For satisfactory operation, external static pressure should not exceed 0.5" w.c.

BLOWER PERFORMANCE DATA - HEATING SPEEDS THREE PHASE

GPG1336090M43A* - Rise Range: 45° - 75°									
Unit Static	LOW			MEDIUM			HIGH		
	CFM	WATTS	RISE	CFM	WATTS	RISE	CFM	WATTS	RISE
0.1	1100	342	62	1469	494	47	1655	604	X
0.2	1037	335	66	1409	480	49	1579	587	X
0.3	991	320	69	1327	459	52	1483	567	46
0.4	926	308	74	1257	442	55	1407	547	49
0.5	831	290	X	1163	419	59	1329	522	52
0.6	773	279	X	1094	398	63	1210	498	57
0.7	669	260	X	942	363	73	1036	464	66
0.8	-	-	-	-	-	-	-	-	-

X = Heating Temperature Rise Not Recommended.

NOTE: The shaded area indicates ranges in excess of maximum external static pressure allowable when heating. For satisfactory operation, external static pressure should not exceed 0.5" w.c.

BLOWER PERFORMANCE DATA - COOLING SPEEDS THREE PHASE

GPG1336***M43A* - COOLING SPEEDS									
Unit	HIGH (Cooling Speed)			MEDIUM (Cooling Speed)			LOW (Cooling Speed)		
Static	CFM	Watts	RPM	CFM	Watts	RPM	CFM	Watts	RPM
0.1	1,655	604	878	1,469	494	804	1,100	342	665
0.2	1,579	587	903	1,409	480	833	1,037	335	697
0.3	1,483	567	925	1,327	459	866	991	320	760
0.4	1,407	547	953	1,257	442	903	926	308	818
0.5	1,329	522	980	1,163	419	942	831	290	872
0.6	1,210	498	1,004	1,094	398	968	773	279	902
0.7	1,036	464	1,033	942	363	1,002	669	260	945
0.8	-	-	-	-	-	-	-	-	-

X = Heating Temperature Rise Not Recommended.

NOTE: The shaded area indicates ranges in excess of maximum external static pressure allowable when heating. For satisfactory operation, external static pressure should not exceed 0.5" w.c.

IGNITION CONTROL DIAGNOSTIC INDICATOR CHART

Light Signal	Refer to Abnormal Heating or Cooling Operation Sections of this Manual
Off	Internal Control Failure
1 Flash	External Lockout
2 Flashes	Pressure Switch Stuck Open
3 Flashes	Pressure Switch Stuck Closed
4 Flashes	Thermal Protection Device Open
5 Flashes	Flame Detected with Gas Valve Closed
6 Flashes	Short Cycle Compressor Delay (Cooling Only)

HEATING TIMING CHART

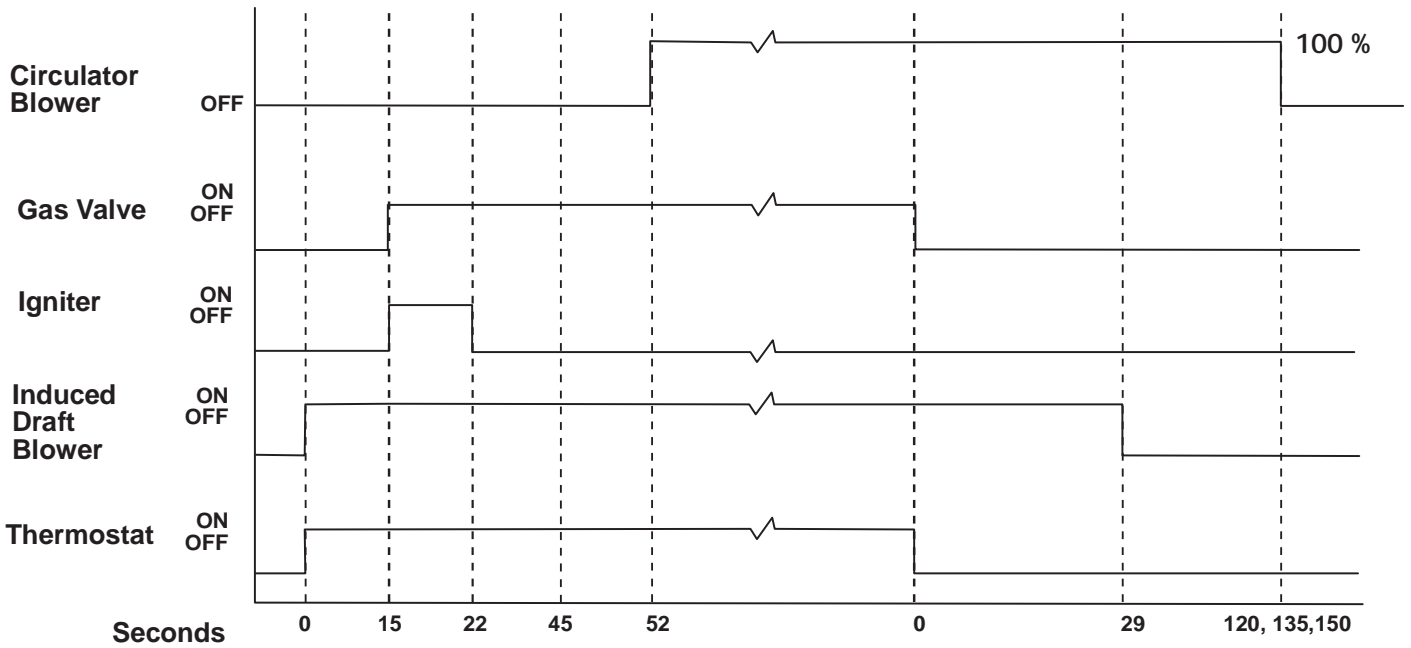

COOLING TIMING CHART

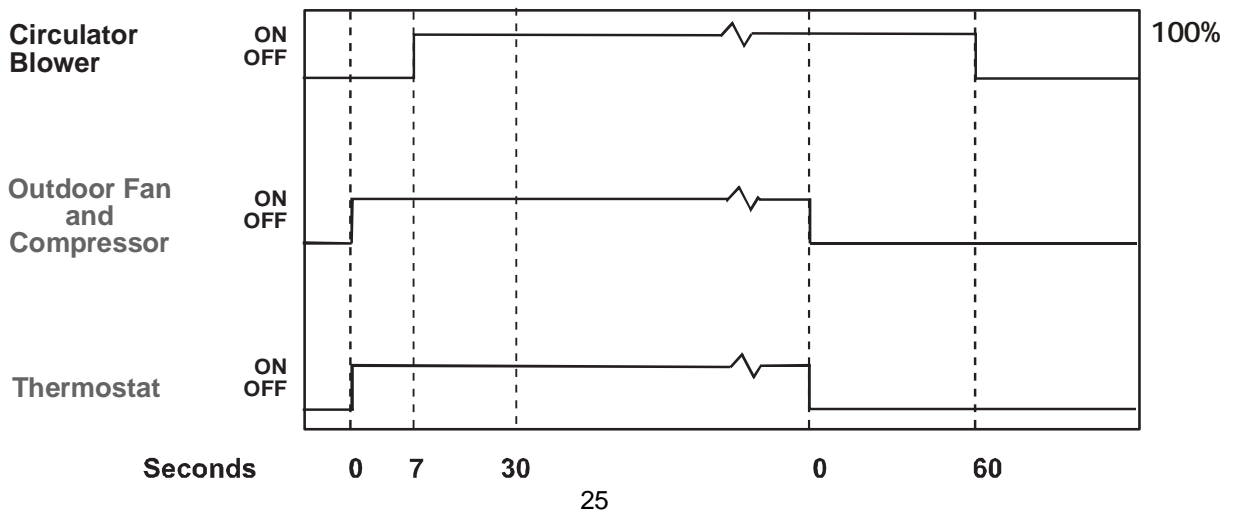

APPENDIX

UNIT DIMENSIONS

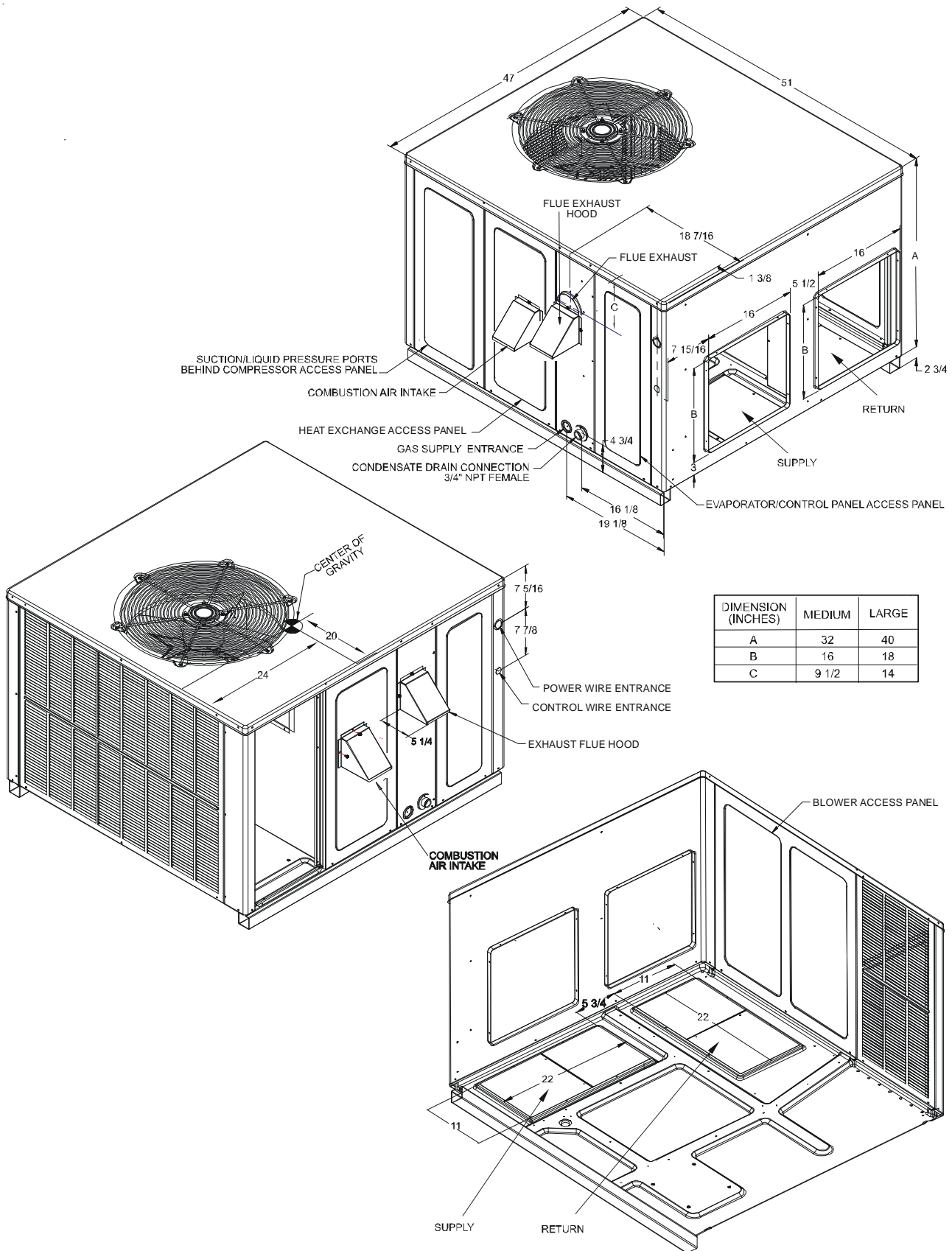

PG13(24, 30, 36, 42)1A WIRING DIAGRAM

WARNING HIGH VOLTAGE!
 DISCONNECT ALL POWER BEFORE SERVICING OR INSTALLING THIS UNIT. MULTIPLE POWER SOURCES MAY BE PRESENT. FAILURE TO DO SO MAY CAUSE PROPERTY DAMAGE, PERSONAL INJURY OR DEATH.

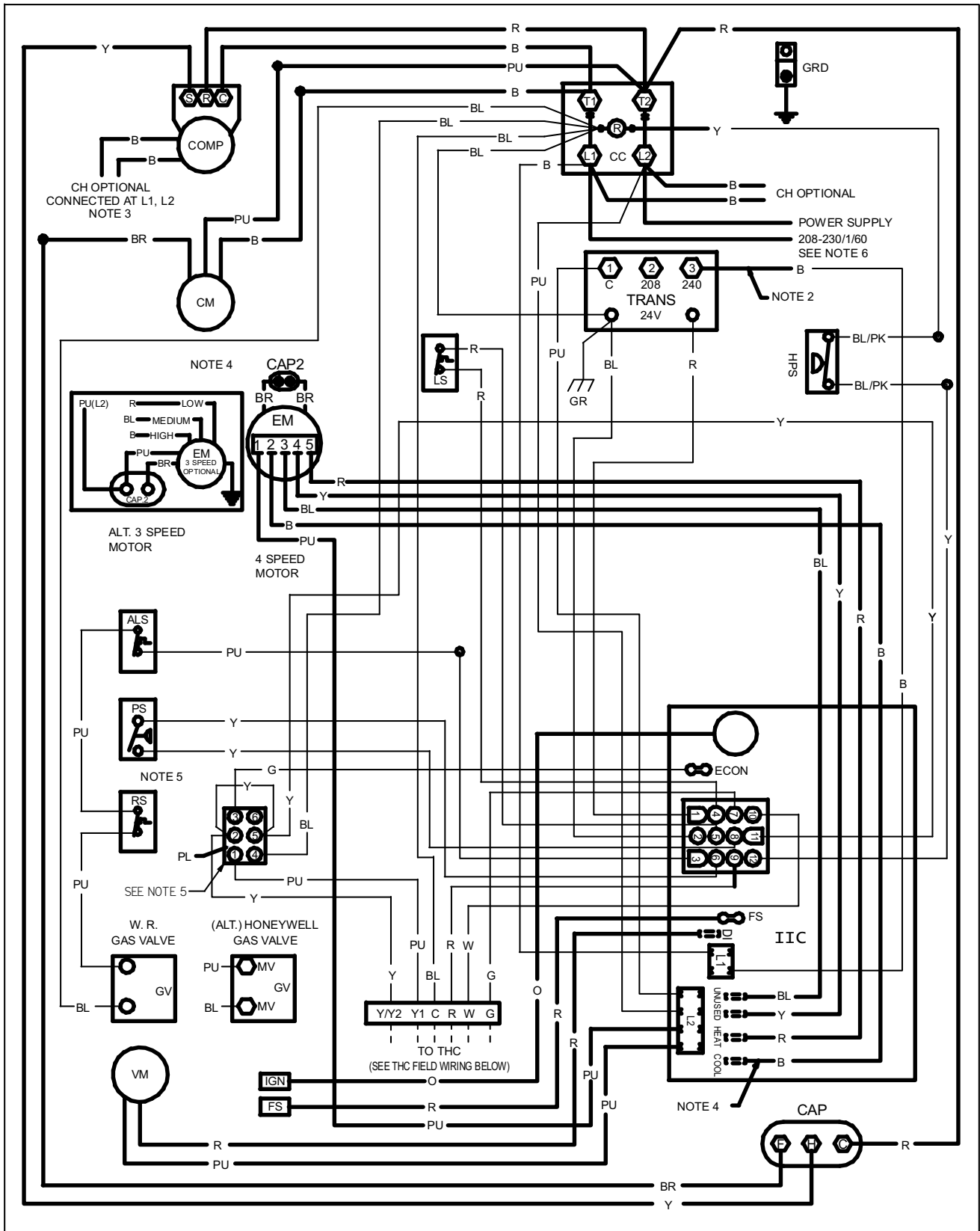

0140G01233 REV. A

Wiring is subject to change. Always refer to the wiring diagram on the unit for the most up-to-date wiring.

PG13(48, 60)1A WIRING DIAGRAM



WARNING

HIGH VOLTAGE!
 DISCONNECT ALL POWER BEFORE SERVICING OR INSTALLING THIS UNIT. MULTIPLE POWER SOURCES MAY BE PRESENT. FAILURE TO DO SO MAY CAUSE PROPERTY DAMAGE, PERSONAL INJURY OR DEATH.



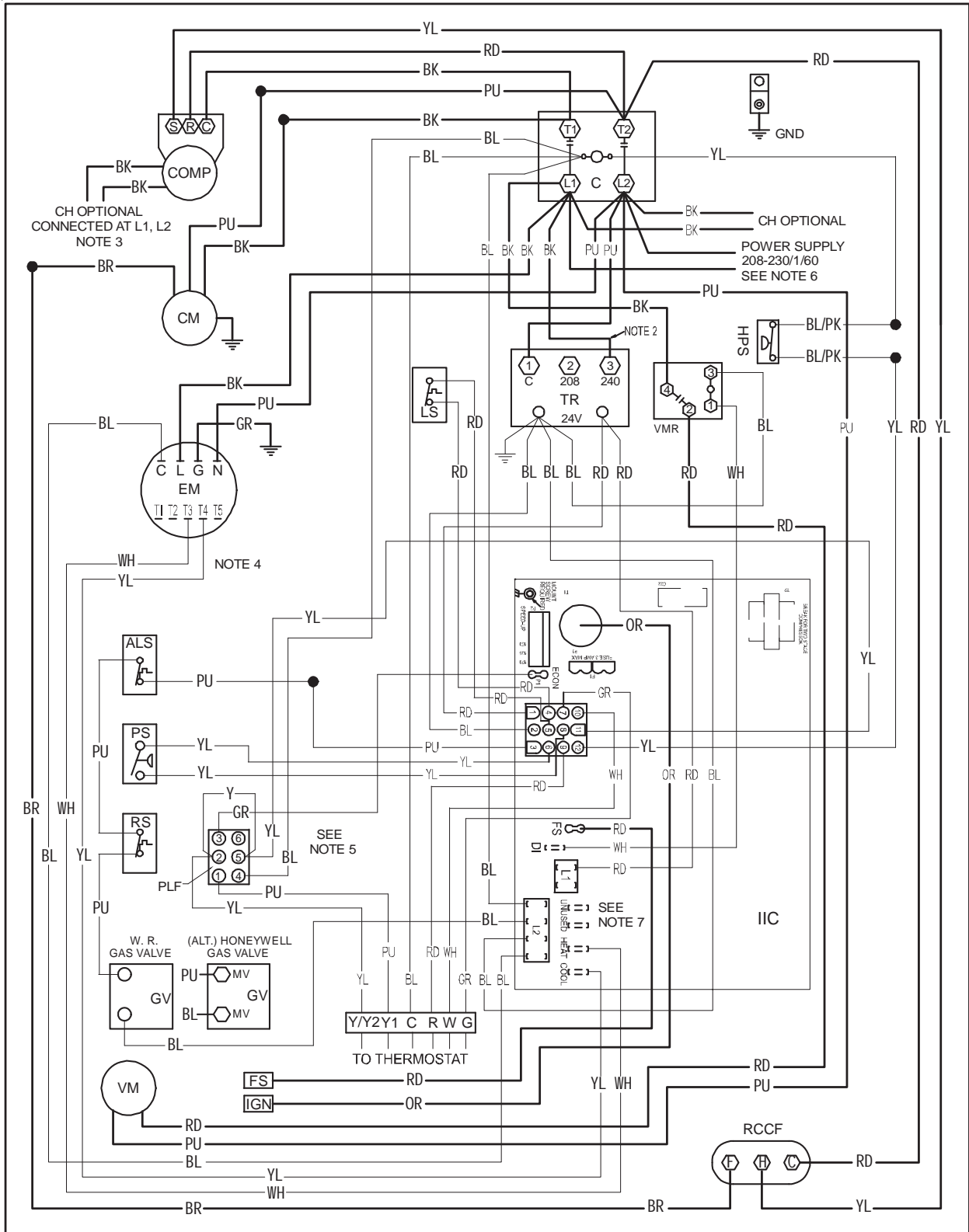

0140G01234 REV A

Wiring is subject to change. Always refer to the wiring diagram on the unit for the most up-to-date wiring.

***PG13(48, 60)1A* WIRING DIAGRAM**

WARNING

HIGH VOLTAGE!

DISCONNECT ALL POWER BEFORE SERVICING OR INSTALLING THIS UNIT. MULTIPLE POWER SOURCES MAY BE PRESENT. FAILURE TO DO SO MAY CAUSE PROPERTY DAMAGE, PERSONAL INJURY OR DEATH.

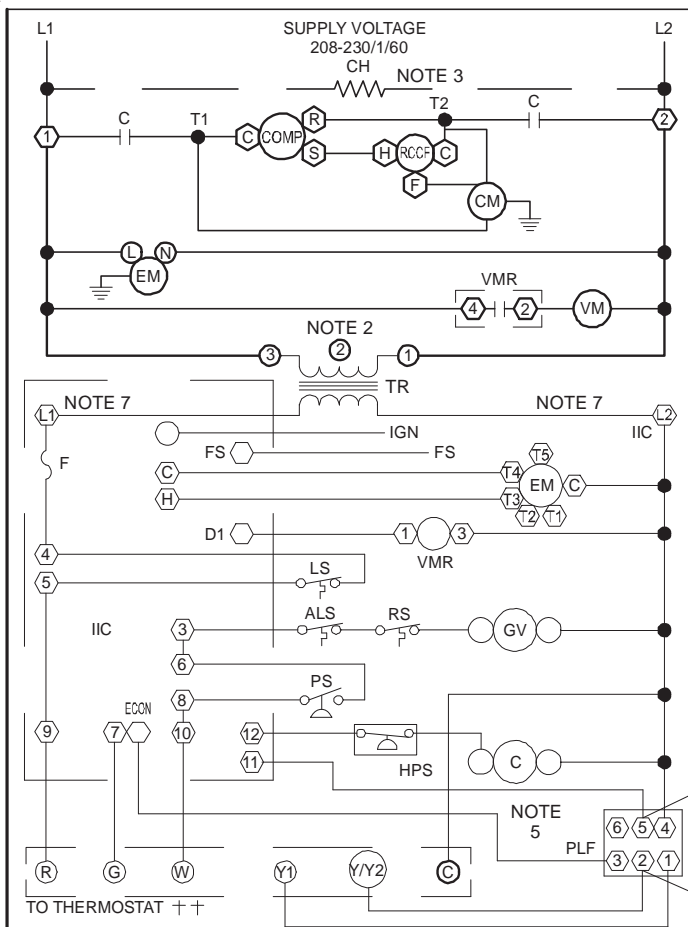

COMPONENT LEGEND

- ALS AUXILIARY LIMIT SWITCH
- COMP COMPRESSOR
- CM CONDENSER MOTOR
- C CONTACTOR
- CH CRANKCASE HEATER
- EM EVAPORATOR MOTOR
- F FUSE
- FS FLAME SENSOR
- GND EQUIPMENT GROUND
- GV GAS VALVE
- IIC INTEGRATED IGNITION CONTROL
- IGN IGNITOR
- LS LIMIT SWITCH
- PLF FEMALE PLUG/CONNECTOR
- PS PRESSURE SWITCH
- RCCF RUN CAPACITOR FOR COMPRESSOR/FAN
- RS ROLLOUT SWITCH
- TR TRANSFORMER
- VM VENT MOTOR
- VMR VENT MOTOR RELAY
- HPS HIGH PRESSURE SWITCH

FACTORY WIRING

- LINE VOLTAGE
- LOW VOLTAGE
- OPTIONAL HIGH VOLTAGE

FIELD WIRING

- HIGH VOLTAGE
- LOW VOLTAGE

WIRE CODE

- BK BLACK
- BL BLUE
- BR BROWN
- GR GREEN
- OR ORANGE
- PK PINK
- PU PURPLE
- RD RED
- WH WHITE
- YL YELLOW
- BL/PK BLUE/PINK

NOTES

1. REPLACEMENT WIRE MUST BE THE SAME SIZE AND TYPE OF INSULATION AS ORIGINAL. (USE COPPER CONDUCTOR ONLY).
2. FOR 208 VOLT TRANSFORMER OPERATION MOVE BLACK WIRE FROM TERMINAL (3) TO TERMINAL (2) ON TRANSFORMER.
3. CRANKCASE HEATER NOT SUPPLIED ON ALL UNITS.
4. FOR DIFFERENT THAN FACTORY SPEED TAP. CHANGE COOLING SPEED AT MOTOR T4 AND T5 TERMINALS. CHANGE HEATING SPEED AT MOTOR T1, T2 AND T3 TERMINALS.

COOLING SPEED (YELLOW WIRE)

- T4 - LOW SPEED
- T5 - HIGH SPEED

HEATING SPEED (WHITE WIRE)

- T1 - LOW SPEED
- T2 - MED. SPEED
- T3 - HIGH SPEED

5. ACCESSORY ECONOMIZER PLUG ADJACENT TO BLOWER HOUSING IN RETURN AIR COMPARTMENT.
6. USE COPPER CONDUCTORS ONLY.
++ USE NEC CLASS 2 WIRE.

208-230/1/60

INSTALLER/SERVICEMAN

THE STATUS LIGHT ON THE FURNACE CONTROL MAY BE USED AS A GUIDE TO TROUBLESHOOTING THIS APPLIANCE. STATUS LIGHT CODES ARE AS FOLLOWS:

STATUS LIGHT	EQUIP. STATUS	CHECK
ON	NORMAL OPERATION	-
OFF	NO POWER OR INTERNAL CONTROL FAULT	CHECK INPUT POWER CHECK FUSE ON CONTROL REPLACE CONTROL
1 BLINK	IGNITION FAILURE OR OPEN ROLLOUT SWITCH OR OPEN AUX. LIMIT SWITCH	GAS FLOW GAS PRESSURE GAS VALVE FLAME SENSOR FLAME ROLLOUT BAD SWITCH AUX. LIMIT OPEN
2 BLINKS	PRESSURE SWITCH OPEN	CHECK PRESSURE SWITCH
3 BLINKS	PRESSURE SWITCH CLOSED WITHOUT INDUCER ON	CHECK PRESSURE SWITCH
4 BLINKS	OPEN LIMIT SWITCH	MAIN LIMIT OPEN BAD SWITCH
5 BLINKS	FALSE FLAME SENSED	STICKING GAS VALVE
6 BLINKS	COMPRESSOR OUTPUT DELAY	3 MIN. COMP. ANTI-CYCLE TIMER

THERMOSTAT FIELD WIRING ++

NO ECONOMIZER

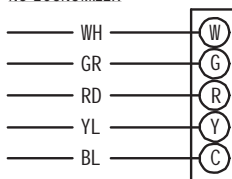

2 STAGE COOLING WITH ECONOMIZER

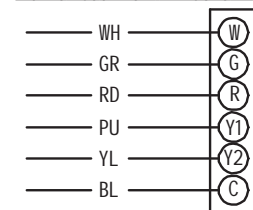

0140G01234 REV A

Wiring is subject to change. Always refer to the wiring diagram on the unit for the most up-to-date wiring.

***PG13(24, 30, 36, 42)1B* WIRING DIAGRAM**



WARNING

HIGH VOLTAGE!
 DISCONNECT ALL POWER BEFORE SERVICING OR INSTALLING THIS UNIT. MULTIPLE POWER SOURCES MAY BE PRESENT. FAILURE TO DO SO MAY CAUSE PROPERTY DAMAGE, PERSONAL INJURY OR DEATH.



FOR UNITS MANUFACTURED BEFORE 3/10/14

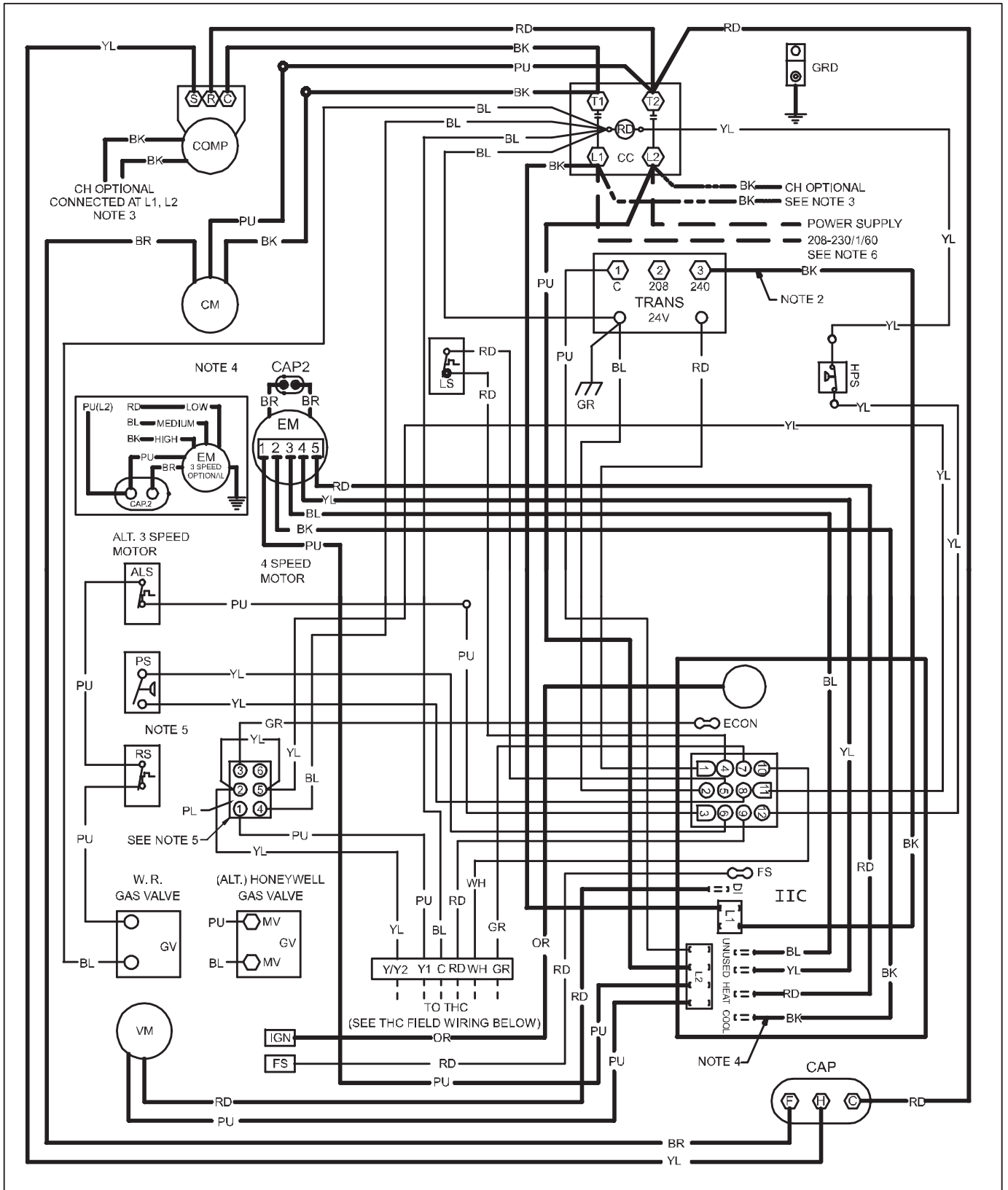

Wiring is subject to change. Always refer to the wiring diagram on the unit for the most up-to-date wiring.

0140G02358-A

***PG13(24, 30, 36, 42)1B* WIRING DIAGRAM**

WARNING

HIGH VOLTAGE!

DISCONNECT ALL POWER BEFORE SERVICING OR INSTALLING THIS UNIT. MULTIPLE POWER SOURCES MAY BE PRESENT. FAILURE TO DO SO MAY CAUSE PROPERTY DAMAGE, PERSONAL INJURY OR DEATH.

FOR UNITS MANUFACTURED BEFORE 3/10/14

COMPONENT LEGEND

<p>ALS AUXILIARY LIMIT SWITCH CAP CAPACITOR COMP COMPRESSOR CM CONDENSER MOTOR CC CONTACTOR CH CRANKCASE HEATER EM EVAPORATOR MOTOR FS FLAME SENSOR GV GAS VALVE IIC INTEGRATED IGNITION CONTROL IGN IGNITOR LS LIMIT SWITCH PL PLUG PS PRESSURE SWITCH RS ROLLOUT SWITCH THC THERMOSTAT HEAT & COOL TRANS TRANSFORMER VM VENT MOTOR HPS HIGH PRESSURE SWITCH</p>	<p>● WIRE SPLICE ○ MARKED TERMINAL ○ UNMARKED TERMINAL</p> <p>WIRING</p> <p>— HIGH VOLTAGE — LOW VOLTAGE - - - FIELD INSTALLED POWER - - - FIELD INSTALLED CONTROL — OPTIONAL HIGH VOLTAGE - - - OPTIONAL LOW VOLTAGE</p> <p>WIRE CODE</p> <p>BK - BLACK BL - BLUE BR - BROWN GR - GREEN OR - ORANGE PK - PINK PU - PURPLE RD - RED WH - WHITE YL - YELLOW BL/PK - BLUE/PINK</p>
-----------------------------------------------------------------------------------------------------------------------------------------------------------------------------------------------------------------------------------------------------------------------------------------------------------------------------------------------------------------------------------------------------------------------------------------------------------------------------------------------------------------------------------------------------------------------------------------------------------------------------------------------------------------------------------------------------------------------------------------------------------------------------------------------------------------------------------------	-----------------------------------------------------------------------------------------------------------------------------------------------------------------------------------------------------------------------------------------------------------------------------------------------------------------------------------------------------------------------------------------------------------------------------------------------------------------------------------------------------------------------------------------------------------------------------------------------------------------------------------------------------------------------------------------------------------------------------------------------------------------------------------------------------------------------------------------

NOTES :

1. REPLACEMENT WIRE MUST BE THE SAME SIZE AND TYPE OF INSULATION AS ORIGINAL.(USE COPPER CONDUCTOR ONLY)
2. FOR 208 VOLT TRANSFORMER OPERATION MOVE BLACK WIRE FROM TERMINAL ③ TO TERMINAL ② ON TRANSFORMER.
3. CRANKCASE HEATER (OPTIONAL).
4. FOR DIFFERENT THAN FACTORY SPEED TAR. CHANGE COOLING SPEED AT COOL TERMINAL (IIC). CHANGE HEATING SPEED AT HEAT TERMINAL (IIC)

<p>4 SPEED MOTOR</p> <p>B - HIGH SPEED BL - MEDIUM HIGH SPEED Y - MEDIUM LOW SPEED R - LOW SPEED</p>	<p>3 SPEED MOTOR</p> <p>B - HIGH SPEED BL - MEDIUM HIGH SPEED R - LOW SPEED</p>
----------------------------------------------------------------------------------------------------------------------------------------------------------------------------------------	------------------------------------------------------------------------------------------------------------------------------------------

5. ACCESSORY ECONOMIZER PLUG ADJACENT TO BLOWER HOUSING IN RETURN AIR COMPARTMENT.
 6. USE COPPER WIRE

INSTALLER/SERVICEMAN

THE STATUS LIGHT ON THE FURNACE CONTROL MAY BE USED AS A GUIDE TO TROUBLESHOOTING THIS APPLIANCE. STATUS LIGHT CODES ARE AS FOLLOWS:

STATUS LIGHT	EQUIP. STATUS	CHECK
ON	NORMAL OPERATION	-
OFF	NO POWER OR INTERNAL CONTROL FAULT	CHECK INPUT POWER CHECK FUSE ON CONTROL REPLACE CONTROL
1 BLINK	IGNITION FAILURE OR OPEN ROLLOUT SWITCH OR OPEN AUX. LIMIT SWITCH	GAS FLOW GAS PRESSURE GAS VALVE FLAME SENSOR FLAME ROLLOUT BAD SWITCH AUX. LIMIT OPEN
2 BLINKS	PRESSURE SWITCH OPEN	CHECK PRESSURE SWITCH
3 BLINKS	PRESSURE SWITCH CLOSED WITHOUT INDUCER ON	CHECK PRESSURE SWITCH
4 BLINKS	OPEN LIMIT SWITCH	MAIN LIMIT OPEN BAD SWITCH
5 BLINKS	FALSE FLAME SENSED	STICKING GAS VALVE
6 BLINKS	COMPRESSOR OUTPUT DELAY	3 MIN. COMP. ANTI-CYCLE TIMER

208-230/1/60

THC-FIELD WIRING

<p>THC-NO ECONOMIZER</p> <p>— WH — (WH) — GR — (GR) — RD — (RD) — YL — (YL) — BL — (C)</p>	<p>2 STAGE COOLING WITH ECONOMIZER</p> <p>— WH — (WH) — GR — (GR) — RD — (RD) — PU — (Y1) — YL — (Y2) — BL — (C)</p>
----------------------------------------------------------------------------------------------------------------------------------------------------------------------------------------------------------------------	----------------------------------------------------------------------------------------------------------------------------------------------------------------------------------------------------------------------------------------------------------------------------

Wiring is subject to change. Always refer to the wiring diagram on the unit for the most up-to-date wiring.

PG13(24, 30, 36, 42)1B WIRING DIAGRAM



WARNING

HIGH VOLTAGE!
 DISCONNECT ALL POWER BEFORE SERVICING OR INSTALLING THIS UNIT. MULTIPLE POWER SOURCES MAY BE PRESENT. FAILURE TO DO SO MAY CAUSE PROPERTY DAMAGE, PERSONAL INJURY OR DEATH.



FOR UNITS MANUFACTURED AFTER 3/9/14

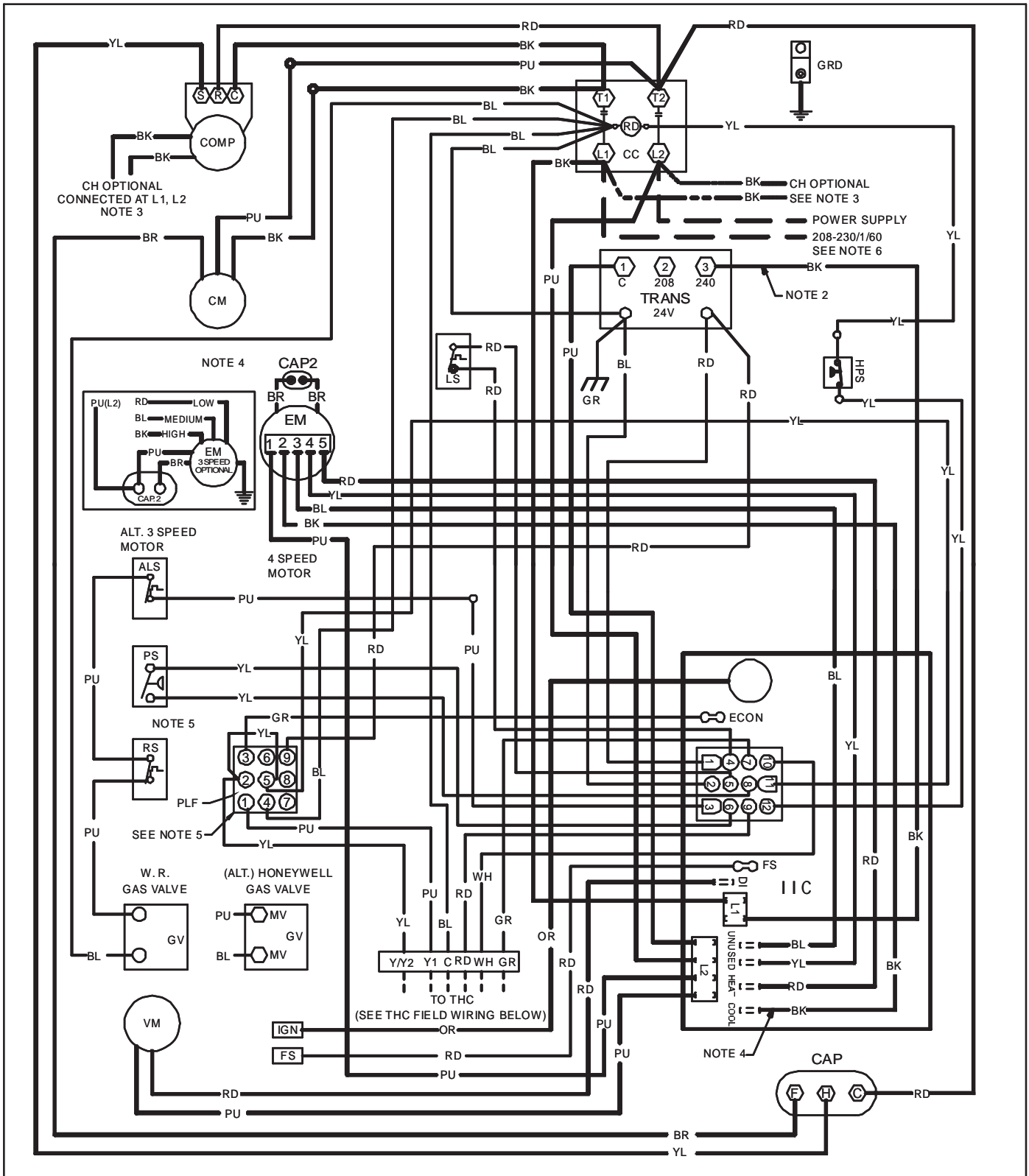

0140G03116-A

Wiring is subject to change. Always refer to the wiring diagram on the unit for the most up-to-date wiring.

PG13(24, 30, 36, 42)1B WIRING DIAGRAM

WARNING

HIGH VOLTAGE!

DISCONNECT ALL POWER BEFORE SERVICING OR INSTALLING THIS UNIT. MULTIPLE POWER SOURCES MAY BE PRESENT. FAILURE TO DO SO MAY CAUSE PROPERTY DAMAGE, PERSONAL INJURY OR DEATH.

FOR UNITS MANUFACTURED AFTER 3/9/14

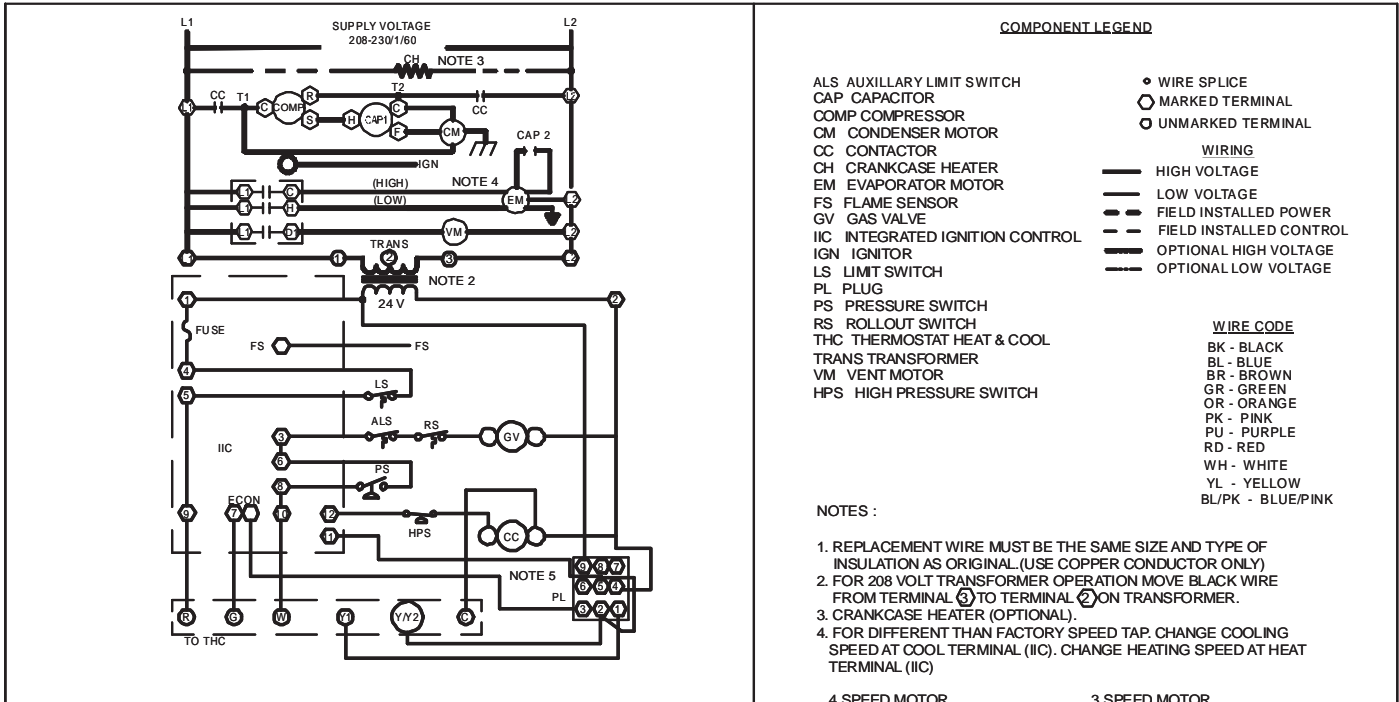

COMPONENT LEGEND

- | | | | |
|-------|-----------------------------|---|-------------------------|
| ALS | AUXILLARY LIMIT SWITCH | ◊ | WIRE SPlice |
| CAP | CAPACITOR | ◯ | MARKED TERMINAL |
| COMP | COMPRESSOR | ◯ | UNMARKED TERMINAL |
| CM | CONDENSER MOTOR | | |
| CC | CONTACTOR | | |
| CH | CRANKCASE HEATER | — | HIGH VOLTAGE |
| EM | EVAPORATOR MOTOR | — | LOW VOLTAGE |
| FS | FLAME SENSOR | — | FIELD INSTALLED POWER |
| GV | GAS VALVE | — | FIELD INSTALLED CONTROL |
| IIC | INTEGRATED IGNITION CONTROL | — | OPTIONAL HIGH VOLTAGE |
| IGN | IGNITOR | — | OPTIONAL LOW VOLTAGE |
| LS | LIMIT SWITCH | | |
| PL | PLUG | | |
| PS | PRESSURE SWITCH | | |
| RS | ROLLOUT SWITCH | | |
| THC | THERMOSTAT HEAT & COOL | | |
| TRANS | TRANSFORMER | | |
| VM | VENT MOTOR | | |
| HPS | HIGH PRESSURE SWITCH | | |
-
- WIRE CODE**
- | | |
|-------|-------------|
| BK | - BLACK |
| BL | - BLUE |
| BR | - BROWN |
| GR | - GREEN |
| OR | - ORANGE |
| PK | - PINK |
| PU | - PURPLE |
| RD | - RED |
| WH | - WHITE |
| YL | - YELLOW |
| BL/PK | - BLUE/PINK |

NOTES :

- REPLACEMENT WIRE MUST BE THE SAME SIZE AND TYPE OF INSULATION AS ORIGINAL. (USE COPPER CONDUCTOR ONLY)
 - FOR 208 VOLT TRANSFORMER OPERATION MOVE BLACK WIRE FROM TERMINAL ⑤ TO TERMINAL ② ON TRANSFORMER.
 - CRANKCASE HEATER (OPTIONAL).
 - FOR DIFFERENT THAN FACTORY SPEED TAP. CHANGE COOLING SPEED AT COOL TERMINAL (IIC). CHANGE HEATING SPEED AT HEAT TERMINAL (IIC)
-
- | | |
|------------------------|------------------------|
| 4 SPEED MOTOR | 3 SPEED MOTOR |
| B - HIGH SPEED | B - HIGH SPEED |
| BL - MEDIUM HIGH SPEED | BL - MEDIUM HIGH SPEED |
| Y - MEDIUM LOW SPEED | R - LOW SPEED |
| R - LOW SPEED | |
-
- ACCESSORY ECONOMIZER PLUG ADJACENT TO BLOWER HOUSING IN RETURN AIR COMPARTMENT.
 - USE COPPER WIRE

208-230/1/60

INSTALLER/SERVICEMAN

THE STATUS LIGHT ON THE FURNACE CONTROL MAY BE USED AS A GUIDE TO TROUBLESHOOTING THIS APPLIANCE. STATUS LIGHT CODES ARE AS FOLLOWS:

STATUS LIGHT	EQUIP. STATUS	CHECK
ON	NORMAL OPERATION	-
OFF	NO POWER OR INTERNAL CONTROL FAULT	CHECK INPUT POWER CHECK FUSE ON CONTROL REPLACE CONTROL
1 BLINK	IGNITION FAILURE OR OPEN ROLLOUT SWITCH OR OPEN AUX. LIMIT SWITCH	GAS FLOW GAS PRESSURE GAS VALVE FLAME SENSOR FLAME ROLLOUT BAD SWITCH AUX. LIMIT OPEN
2 BLINKS	PRESSURE SWITCH OPEN	CHECK PRESSURE SWITCH
3 BLINKS	PRESSURE SWITCH CLOSED WITHOUT INDUCER ON	CHECK PRESSURE SWITCH
4 BLINKS	OPEN LIMIT SWITCH	MAIN LIMIT OPEN BAD SWITCH
5 BLINKS	FALSE FLAME SENSED	STICKING GAS VALVE
6 BLINKS	COMPRESSOR OUTPUT DELAY	3 MIN. COMP. ANTI-CYCLE TIMER

THC-FIELD WIRING

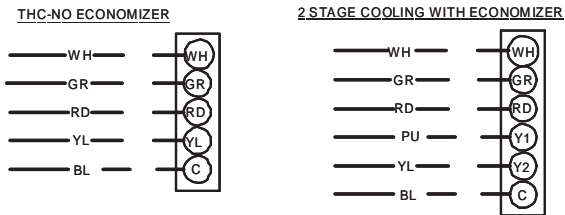

0140G03 116-A

Wiring is subject to change. Always refer to the wiring diagram on the unit for the most up-to-date wiring.

***PG13(48, 60)1B* WIRING DIAGRAM**



WARNING

HIGH VOLTAGE!
DISCONNECT ALL POWER BEFORE SERVICING OR INSTALLING THIS UNIT. MULTIPLE POWER SOURCES MAY BE PRESENT. FAILURE TO DO SO MAY CAUSE PROPERTY DAMAGE, PERSONAL INJURY OR DEATH.



FOR UNITS MANUFACTURED BEFORE 3/10/14

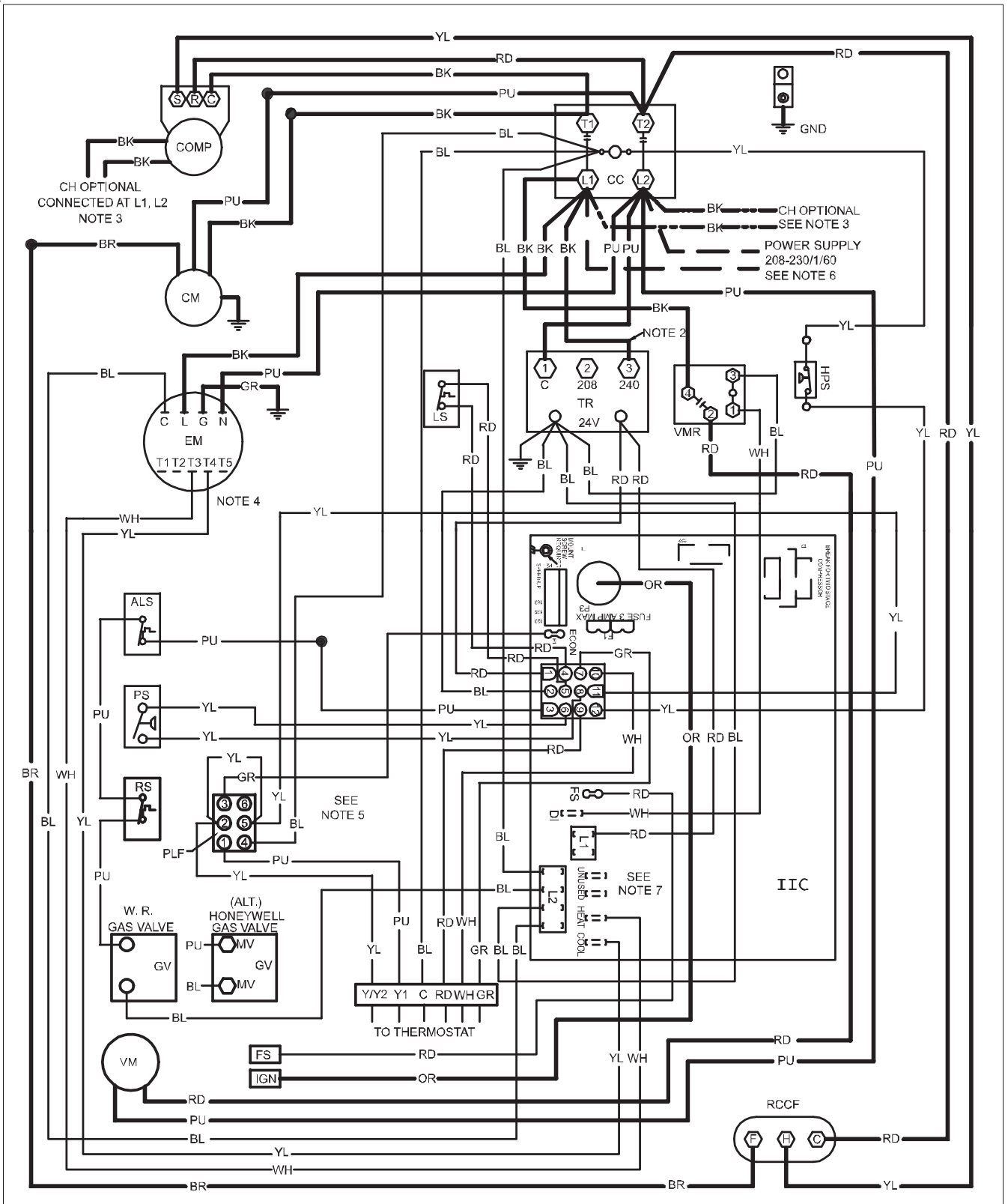

0140G02359-A

Wiring is subject to change. Always refer to the wiring diagram on the unit for the most up-to-date wiring.

***PG13(48, 60)1B* WIRING DIAGRAM**

WARNING

HIGH VOLTAGE!

DISCONNECT ALL POWER BEFORE SERVICING OR INSTALLING THIS UNIT. MULTIPLE POWER SOURCES MAY BE PRESENT. FAILURE TO DO SO MAY CAUSE PROPERTY DAMAGE, PERSONAL INJURY OR DEATH.

FOR UNITS MANUFACTURED BEFORE 3/10/14

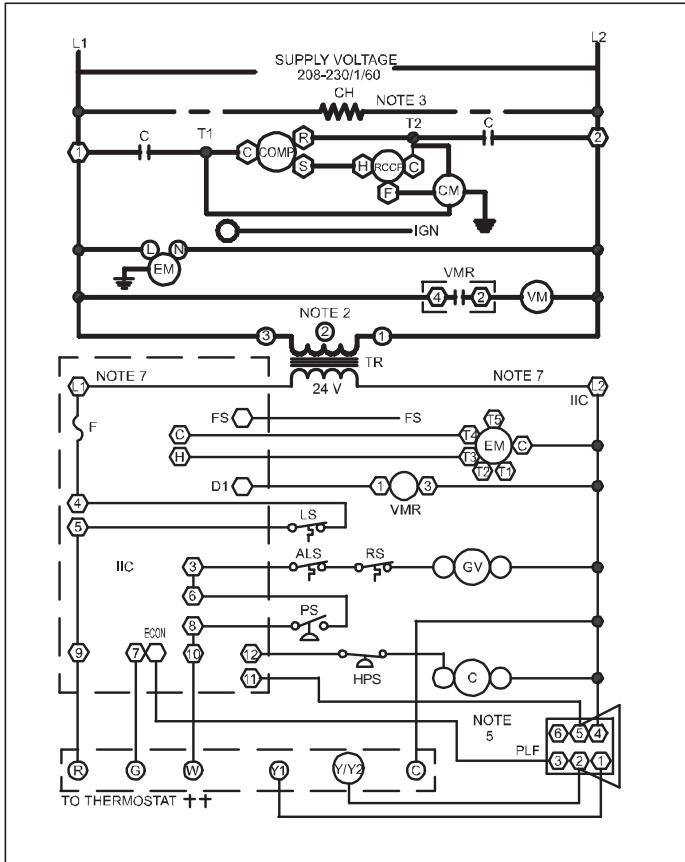

COMPONENT LEGEND

- ALS AUXILIARY LIMIT SWITCH
- COMP COMPRESSOR
- CM CONDENSER MOTOR
- C CONTACTOR
- CH CRANKCASE HEATER
- EM EVAPORATOR MOTOR
- F FUSE
- FS FLAME SENSOR
- GND EQUIPMENT GROUND
- GV GAS VALVE
- IIC INTEGRATED IGNITION CONTROL
- IGN IGNITOR
- LS LIMIT SWITCH
- PLF FEMALE PLUG/CONNECTOR
- PS PRESSURE SWITCH
- RCCF RUN CAPACITOR FOR COMPRESSOR/FAN
- RS ROLLOUT SWITCH
- TR TRANSFORMER
- VM VENT MOTOR
- VMR VENT MOTOR RELAY
- HPS HIGH PRESSURE SWITCH

WIRING

- HIGH VOLTAGE
- LOW VOLTAGE
- FIELD INSTALLED POWER
- FIELD INSTALLED CONTROL
- OPTIONAL HIGH VOLTAGE
- OPTIONAL LOW VOLTAGE

WIRE CODE

- BK - BLACK
- BL - BLUE
- BR - BROWN
- GR - GREEN
- OR - ORANGE
- PK - PINK
- PU - PURPLE
- RD - RED
- WH - WHITE
- YL - YELLOW
- BL/PK - BLUE/PINK

NOTES :

1. REPLACEMENT WIRE MUST BE THE SAME SIZE AND TYPE OF INSULATION AS ORIGINAL (USE COPPER CONDUCTOR ONLY).
2. FOR 208 VOLT TRANSFORMER OPERATION MOVE BLACK WIRE FROM TERMINAL ① TO TERMINAL ② ON TRANSFORMER.
3. CRANKCASE HEATER NOT SUPPLIED ON ALL UNITS.
4. FOR DIFFERENT THAN FACTORY SPEED TAP, CHANGE COOLING SPEED AT MOTOR T4 AND T5 TERMINALS. CHANGE HEATING SPEED AT MOTOR T1, T2 AND T3 TERMINALS.

COOLING SPEED (YELLOW WIRE)

- T4 - LOW SPEED
- T5 - HIGH SPEED

HEATING SPEED (WHITE WIRE)

- T1 - LOW SPEED
- T2 - MED. SPEED
- T3 - HIGH SPEED

5. ACCESSORY ECONOMIZER PLUG ADJACENT TO BLOWER HOUSING IN RETURN AIR COMPARTMENT.
6. USE COPPER CONDUCTORS ONLY

++ USE NEC CLASS 2 WIRE.

208-230/1/60

INSTALLER/SERVICEMAN
THE STATUS LIGHT ON THE FURNACE CONTROL MAY BE USED AS A GUIDE TO TROUBLESHOOTING THIS APPLIANCE. STATUS LIGHT CODES ARE AS FOLLOWS:

STATUS LIGHT	EQUIP. STATUS	CHECK
ON	NORMAL OPERATION	-
OFF	NO POWER OR INTERNAL CONTROL FAULT	CHECK INPUT POWER CHECK FUSE ON CONTROL REPLACE CONTROL
1 BLINK	IGNITION FAILURE OR OPEN ROLLOUT SWITCH OR OPEN AUX. LIMIT SWITCH	GAS FLOW GAS PRESSURE GAS VALVE FLAME SENSOR FLAME ROLLOUT BAD SWITCH AUX. LIMIT OPEN
2 BLINKS	PRESSURE SWITCH OPEN	CHECK PRESSURE SWITCH
3 BLINKS	PRESSURE SWITCH CLOSED WITHOUT INDUCER ON	CHECK PRESSURE SWITCH
4 BLINKS	OPEN LIMIT SWITCH	MAIN LIMIT OPEN BAD SWITCH
5 BLINKS	FALSE FLAME SENSED	STICKING GAS VALVE
6 BLINKS	COMPRESSOR OUTPUT DELAY	3 MIN. COMP. ANTI-CYCLE TIMER

THERMOSTAT FIELD WIRING ++

NO ECONOMIZER

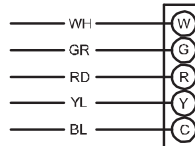

2 STAGE COOLING WITH ECONOMIZER

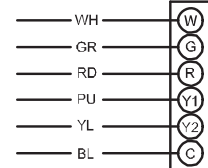

0140G02359-A

Wiring is subject to change. Always refer to the wiring diagram on the unit for the most up-to-date wiring.

PG13(48, 60)1B WIRING DIAGRAM

WARNING

HIGH VOLTAGE!
 DISCONNECT ALL POWER BEFORE SERVICING OR INSTALLING THIS UNIT. MULTIPLE POWER SOURCES MAY BE PRESENT. FAILURE TO DO SO MAY CAUSE PROPERTY DAMAGE, PERSONAL INJURY OR DEATH.

FOR UNITS MANUFACTURED AFTER 3/9/14

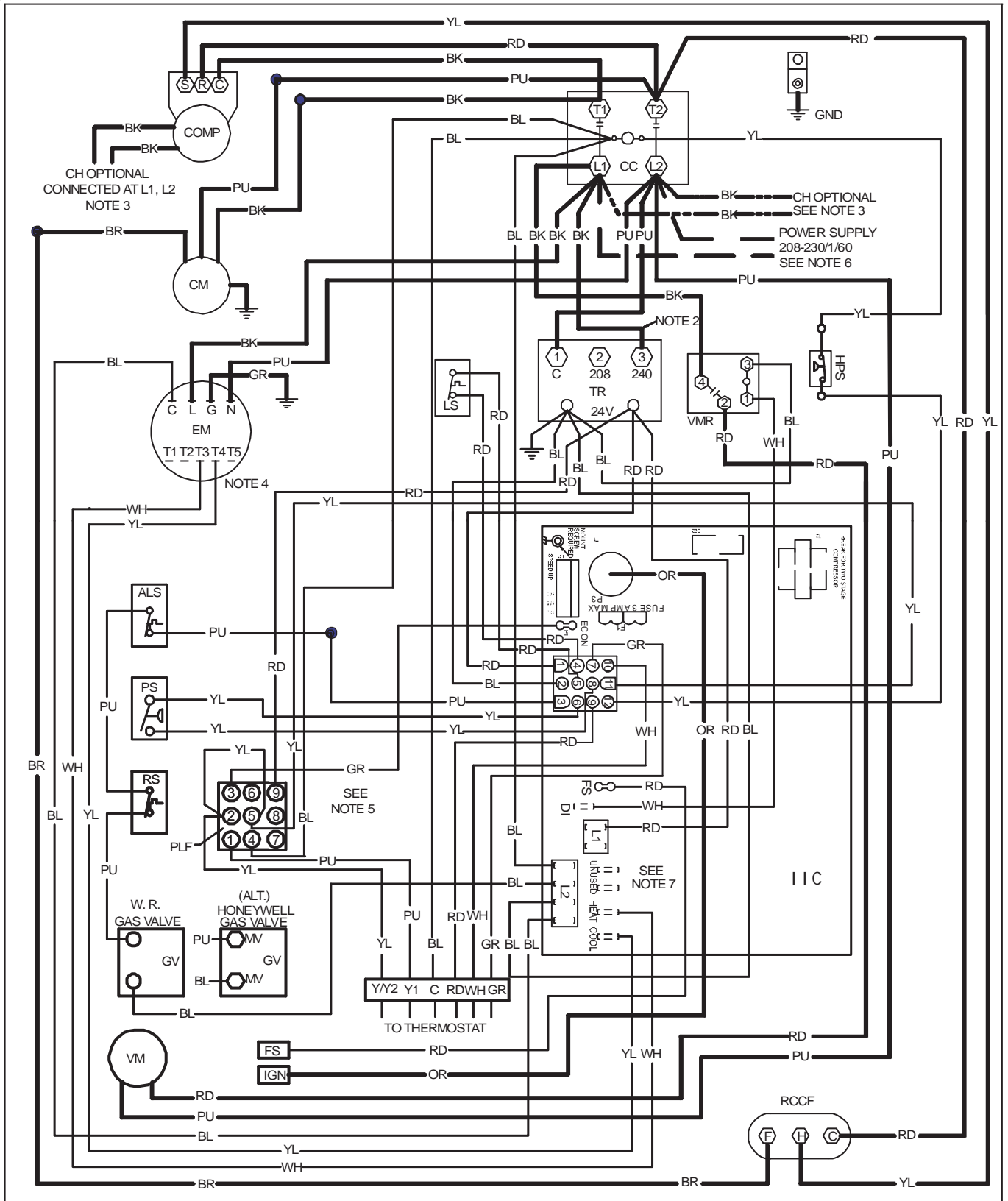

0140G03117-A

Wiring is subject to change. Always refer to the wiring diagram on the unit for the most up-to-date wiring.

***PG13(48, 60)1B* WIRING DIAGRAM**

WARNING

HIGH VOLTAGE!

DISCONNECT ALL POWER BEFORE SERVICING OR INSTALLING THIS UNIT. MULTIPLE POWER SOURCES MAY BE PRESENT. FAILURE TO DO SO MAY CAUSE PROPERTY DAMAGE, PERSONAL INJURY OR DEATH.

FOR UNITS MANUFACTURED AFTER 3/9/14

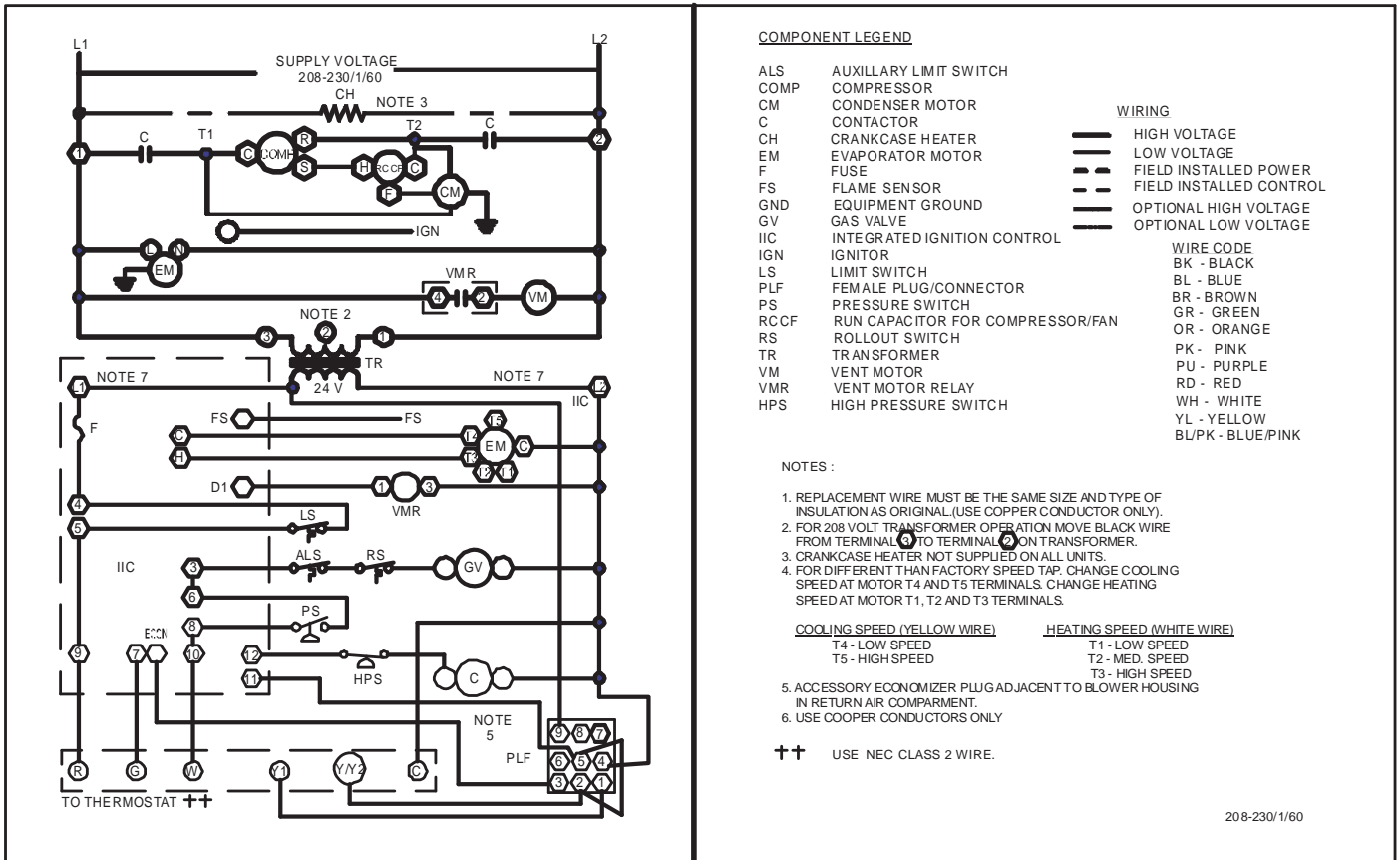

INSTALLER/SERVICEMAN
THE STATUS LIGHT ON THE FURNACE CONTROL MAY BE USED AS A GUIDE TO TROUBLESHOOTING THIS APPLIANCE. STATUS LIGHT CODES ARE AS FOLLOWS:

STATUS LIGHT	EQUIP. STATUS	CHECK
ON	NORMAL OPERATION	-
OFF	NO POWER OR INTERNAL CONTROL FAULT	CHECK INPUT POWER CHECK FUSE ON CONTROL REPLACE CONTROL
1 BLINK	IGNITION FAILURE OR OPEN ROLLOUT SWITCH OR OPEN AUX. LIMIT SWITCH	GAS FLOW GAS PRESSURE GAS VALVE FLAME SENSOR FLAME ROLLOUT BAD SWITCH AUX. LIMIT OPEN
2 BLINKS	PRESSURE SWITCH OPEN	CHECK PRESSURE SWITCH
3 BLINKS	PRESSURE SWITCH CLOSED WITHOUT INDUCER ON	CHECK PRESSURE SWITCH
4 BLINKS	OPEN LIMIT SWITCH	MAIN LIMIT OPEN BAD SWITCH
5 BLINKS	FALSE FLAME SENSED	STICKING GAS VALVE
6 BLINKS	COMPRESSOR OUTPUT DELAY	3 MIN. COMP. ANTI-CYCLE IIMLR

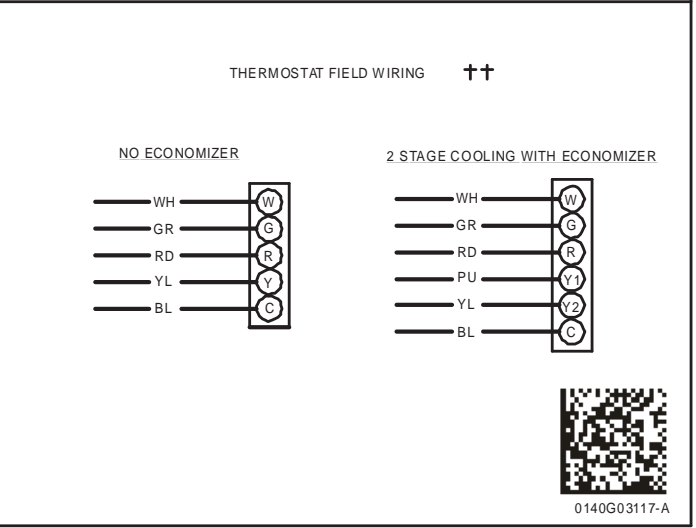

Wiring is subject to change. Always refer to the wiring diagram on the unit for the most up-to-date wiring.

GPG13(36)3** WIRING DIAGRAM



WARNING

HIGH VOLTAGE!
 DISCONNECT ALL POWER BEFORE SERVICING OR INSTALLING THIS UNIT. MULTIPLE POWER SOURCES MAY BE PRESENT. FAILURE TO DO SO MAY CAUSE PROPERTY DAMAGE, PERSONAL INJURY OR DEATH.



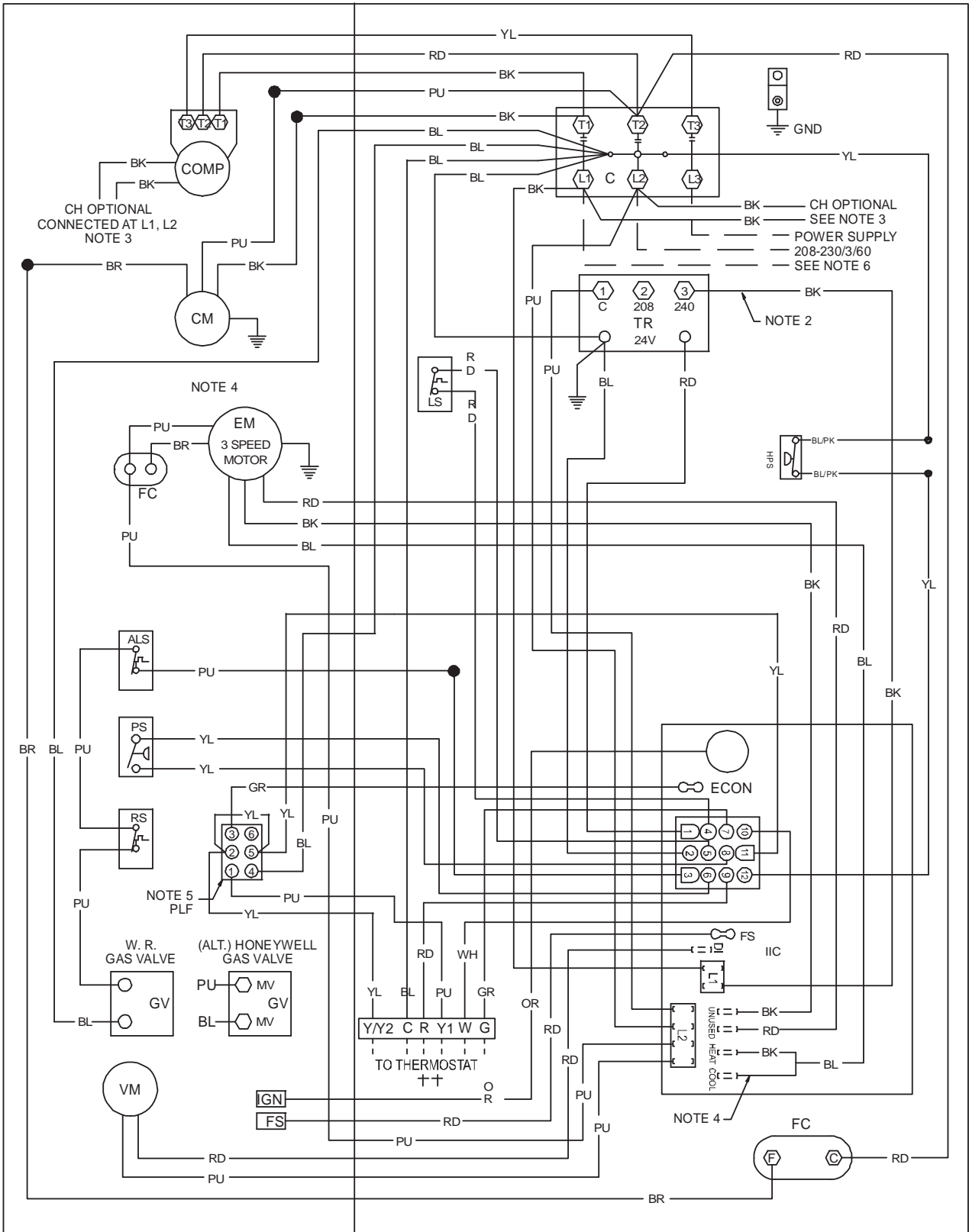

0140G01001 REV. A

Wiring is subject to change. Always refer to the wiring diagram on the unit for the most up-to-date wiring.

GPG13(36)3** WIRING DIAGRAM



WARNING

HIGH VOLTAGE!
DISCONNECT ALL POWER BEFORE SERVICING OR INSTALLING THIS UNIT. MULTIPLE POWER SOURCES MAY BE PRESENT. FAILURE TO DO SO MAY CAUSE PROPERTY DAMAGE, PERSONAL INJURY OR DEATH.



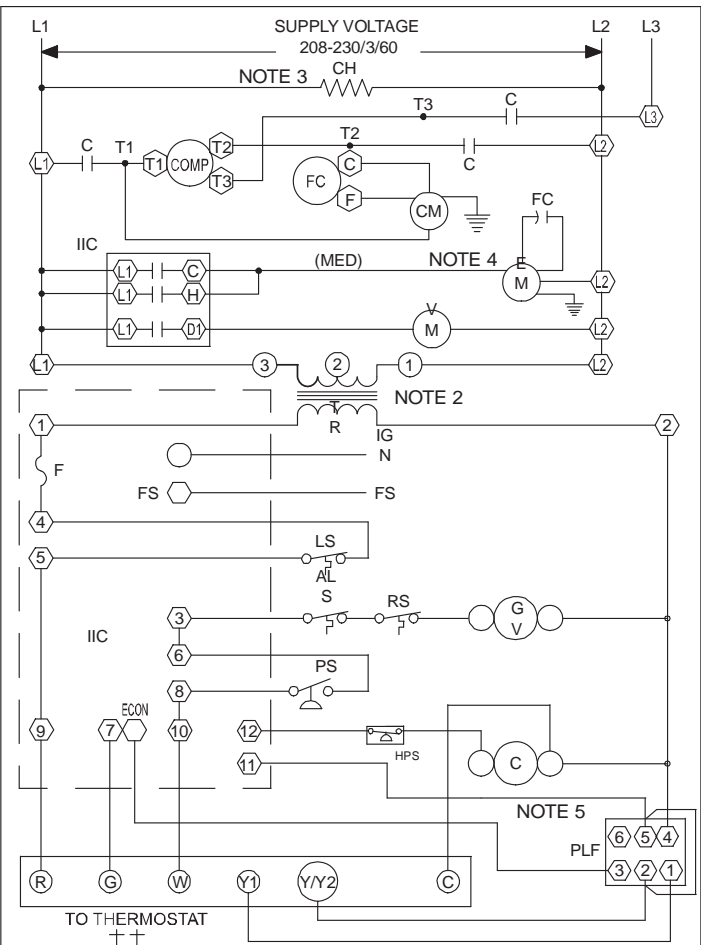

- COMPONENT LEGEND**
- ALS AUXILIARY LIMIT SWITCH
 - COMP COMPRESSOR
 - CM CONDENSER MOTOR
 - C CONTACTOR
 - CH CRANKCASE HEATER
 - EM EVAPORATOR MOTOR
 - F FUSE
 - FC FAN CAPACITOR
 - FS FLAME SENSOR
 - GND EQUIPMENT GROUND
 - GV GAS VALVE
 - IIC INTEGRATED IGNITION CONTROL
 - IGN IGNITOR
 - LS LIMIT SWITCH
 - PLF FEMALE PLUG/CONNECTOR
 - PS PRESSURE SWITCH
 - RS ROLLOUT SWITCH
 - TR TRANSFORMER
 - VM VENT MOTOR
 - HPS HIGH PRESSURE SWITCH
- FACTORY WIRING**
- LINE VOLTAGE
 - LOW VOLTAGE
 - OPTIONAL HIGH VOLTAGE
- FIELD WIRING**
- HIGH VOLTAGE
 - - - LOW VOLTAGE
- WIRE CODE**
- BK BLACK
 - BL BLUE
 - BR BROWN
 - GR GREEN
 - OR ORANGE
 - PK PINK
 - PU PURPLE
 - RD RED
 - WH WHITE
 - YL YELLOW
 - BL/PK BLUE/PINK

- NOTES**
1. REPLACEMENT WIRE MUST BE THE SAME SIZE AND TYPE OF INSULATION AS ORIGINAL.(USE COPPER CONDUCTOR ONLY).
 2. FOR 208 VOLT TRANSFORMER OPERATION MOVE BLACK WIRE FROM TERMINAL (3) TO TERMINAL (2) ON TRANSFORMER.
 3. CRANKCASE HEATER NOT SUPPLIED ON ALL UNITS.
 4. FOR DIFFERENT THAN FACTORY SPEED TAP. CHANGE COOLING SPEED AT COOL TERMINAL (IIC). CHANGE HEATING SPEED AT HEAT TERMINAL (IIC)
- 3 SPEED MOTOR**
- BK - HIGH SPEED
 - BL - MEDIUM SPEED
 - RD - LOW SPEED
5. ACCESSORY ECONOMIZER PLUG (ON SELECT MODELS) ADJACENT TO BLOWER HOUSING IN RETURN AIR COMPARTMENT.
 6. USE COOPER CONDUCTORS ONLY.
 †† USE NEC CLASS 2 WIRE.
- 208-230/3/60

INSTALLER/SERVICEMAN

THE STATUS LIGHT ON THE FURNACE CONTROL MAY BE USED AS A GUIDE TO TROUBLESHOOTING THIS APPLIANCE. STATUS LIGHT CODES ARE AS FOLLOWS:

STATUS LIGHT	EQUIP. STATUS	CHECK
ON	NORMAL OPERATION	-
OFF	NO POWER OR INTERNAL CONTROL FAULT	CHECK INPUT POWER CHECK FUSE ON CONTROL REPLACE CONTROL
1 BLINK	IGNITION FAILURE OR OPEN ROLLOUT SWITCH OR OPEN AUX. LIMIT SWITCH	GAS FLOW GAS PRESSURE GAS VALVE FLAME SENSOR FLAME ROLLOUT BAD SWITCH AUX. LIMIT OPEN
2 BLINKS	PRESSURE SWITCH OPEN	CHECK PRESSURE SWITCH
3 BLINKS	PRESSURE SWITCH CLOSED WITHOUT INDUCER ON	CHECK PRESSURE SWITCH
4 BLINKS	OPEN LIMIT SWITCH	MAIN LIMIT OPEN BAD SWITCH
5 BLINKS	FALSE FLAME SENSED	STICKING GAS VALVE
6 BLINKS	COMPRESSOR OUTPUT DELAY	3 MIN. COMP. ANTI-CYCLE TIMER

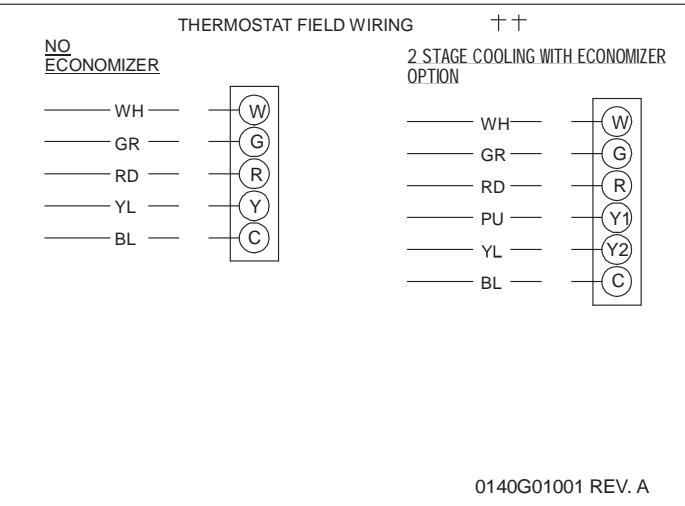

GPG13(48, 60)3** WIRING DIAGRAM

WARNING

HIGH VOLTAGE!
 DISCONNECT ALL POWER BEFORE SERVICING OR INSTALLING THIS UNIT. MULTIPLE POWER SOURCES MAY BE PRESENT. FAILURE TO DO SO MAY CAUSE PROPERTY DAMAGE, PERSONAL INJURY OR DEATH.

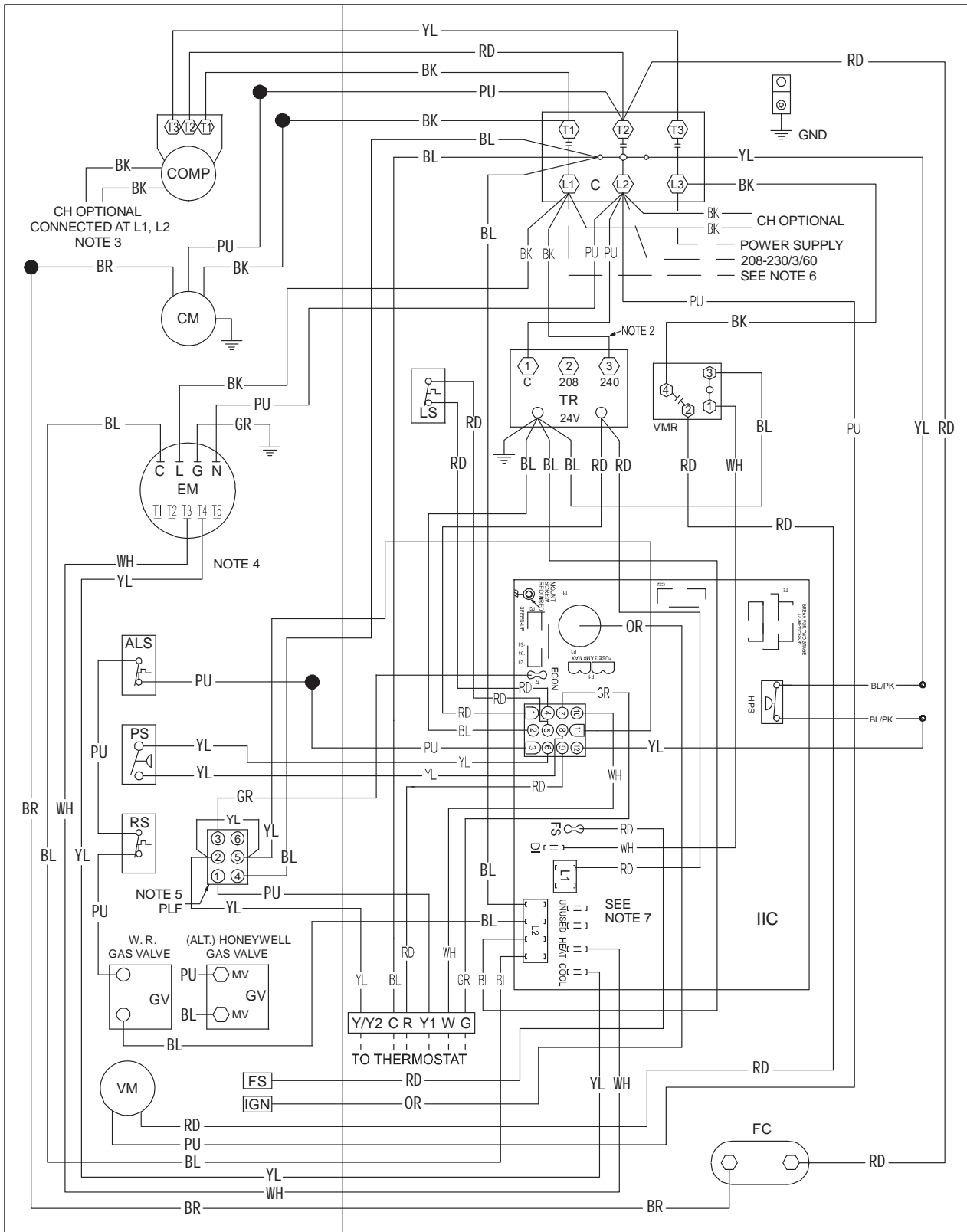

0140G01002 REV. A

Wiring is subject to change. Always refer to the wiring diagram on the unit for the most up-to-date wiring.

GPG13(48, 60)3** WIRING DIAGRAM



WARNING

HIGH VOLTAGE!
DISCONNECT ALL POWER BEFORE SERVICING OR INSTALLING THIS UNIT. MULTIPLE POWER SOURCES MAY BE PRESENT. FAILURE TO DO SO MAY CAUSE PROPERTY DAMAGE, PERSONAL INJURY OR DEATH.



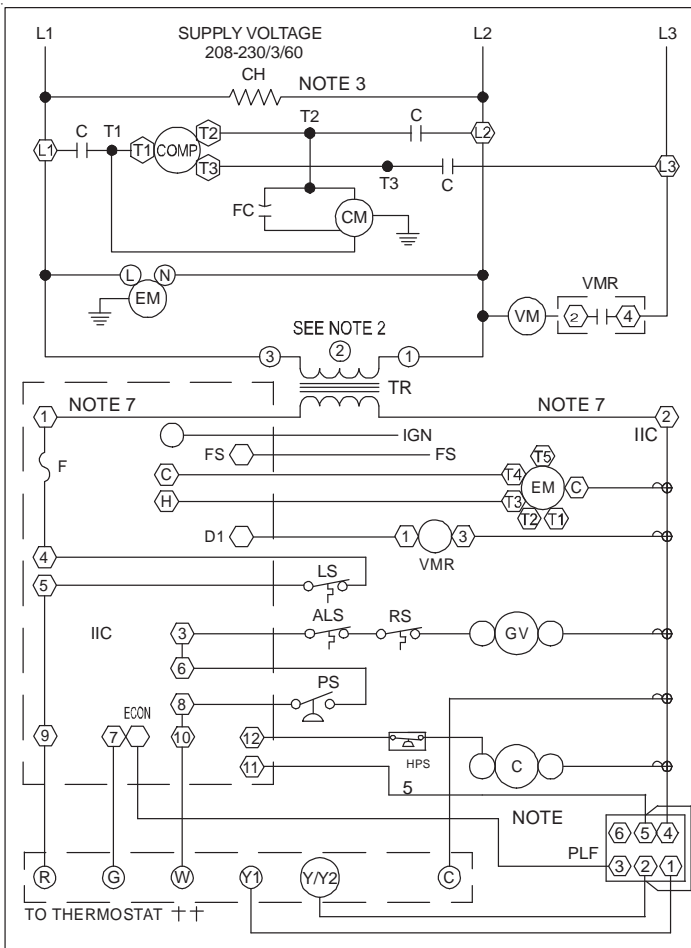

- COMPONENT LEGEND**
- ALS AUXILIARY LIMIT SWITCH
 - COMP COMPRESSOR
 - CM CONDENSER MOTOR
 - C CONTACTOR
 - CH CRANKCASE HEATER
 - EM EVAPORATOR MOTOR
 - F FUSE
 - FC FAN CAPACITOR
 - FS FLAME SENSOR
 - GND EQUIPMENT GROUND
 - GV GAS VALVE
 - IIC INTEGRATED IGNITION CONTROL
 - IGN IGNITOR
 - LS LIMIT SWITCH
 - PLF FEMALE PLUG/CONNECTOR
 - PS PRESSURE SWITCH
 - RS ROLLOUT SWITCH
 - TR TRANSFORMER
 - VM VENT MOTOR
 - VMR VENT MOTOR RELAY
 - HPS HIGH PRESSURE SWITCH
- FACTORY WIRING**
- LINE VOLTAGE
 - LOW VOLTAGE
 - OPTIONAL HIGH VOLTAGE
- FIELD WIRING**
- HIGH VOLTAGE
 - LOW VOLTAGE
- WIRE CODE**
- BK BLACK
 - BL BLUE
 - BR BROWN
 - GR GREEN
 - OR ORANGE
 - PK PINK
 - PU PURPLE
 - RD RED
 - WH WHITE
 - YL YELLOW
 - BL/PK BLUE/PINK

- NOTES**
1. REPLACEMENT WIRE MUST BE THE SAME SIZE AND TYPE OF INSULATION AS ORIGINAL (USE COPPER CONDUCTOR ONLY).
 2. FOR 208 VOLT TRANSFORMER OPERATION MOVE BLACK WIRE FROM TERMINAL (3) TO TERMINAL (2) ON TRANSFORMER.
 3. CRANKCASE HEATER NOT SUPPLIED ON ALL UNITS.
 4. FOR DIFFERENT THAN FACTORY SPEED TAP. CHANGE COOLING SPEED AT MOTOR T4 AND T5 TERMINALS. CHANGE HEATING SPEED AT MOTOR T1, T2 AND T3 TERMINALS.
- | | |
|------------------------------------|-----------------------------------|
| COOLING SPEED (YELLOW WIRE) | HEATING SPEED (WHITE WIRE) |
| T4 - LOW SPEED | T1 - LOW SPEED |
| T5 - HIGH SPEED | T2 - MED. SPEED |
| | T3 - HIGH SPEED |
5. ACCESSORY ECONOMIZER PLUG (ON SELECT MODELS) ADJACENT TO BLOWER HOUSING IN RETURN AIR COMPARTMENT.
 6. USE COOPER CONDUCTORS ONLY.
 ++ USE NEC CLASS 2 WIRE.
 7. L1 AND L2 ON ICC CONTROL IS 24V INPUT.
- 208-230/3/60

INSTALLER/SERVICEMAN

THE STATUS LIGHT ON THE FURNACE CONTROL MAY BE USED AS A GUIDE TO TROUBLESHOOTING THIS APPLIANCE. STATUS LIGHT CODES ARE AS FOLLOWS:

STATUS LIGHT	EQUIP. STATUS	CHECK
ON	NORMAL OPERATION	-
OFF	NO POWER OR INTERNAL CONTROL FAULT	CHECK INPUT POWER CHECK FUSE ON CONTROL REPLACE CONTROL
1 BLINK	IGNITION FAILURE OR OPEN ROLLOUT SWITCH OR OPEN AUX. LIMIT SWITCH	GAS FLOW GAS PRESSURE GAS VALVE FLAME SENSOR FLAME ROLLOUT BAD SWITCH AUX. LIMIT OPEN
2 BLINKS	PRESSURE SWITCH OPEN	CHECK PRESSURE SWITCH
3 BLINKS	PRESSURE SWITCH CLOSED WITHOUT INDUCER ON	CHECK PRESSURE SWITCH
4 BLINKS	OPEN LIMIT SWITCH	MAIN LIMIT OPEN BAD SWITCH
5 BLINKS	FALSE FLAME SENSED	STICKING GAS VALVE
6 BLINKS	COMPRESSOR OUTPUT DELAY	3 MIN. COMP. ANTI-CYCLE TIMER

THERMOSTAT FIELD WIRING ++

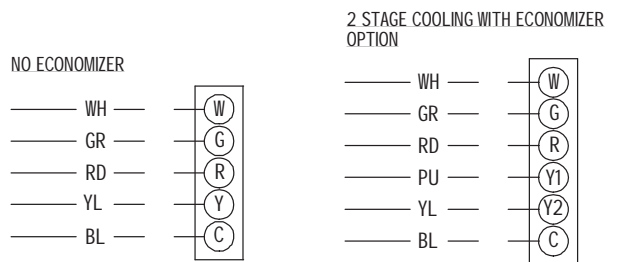

0140G01002 REV. A

Wiring is subject to change. Always refer to the wiring diagram on the unit for the most up-to-date wiring.

MINIMUM CLEARANCES

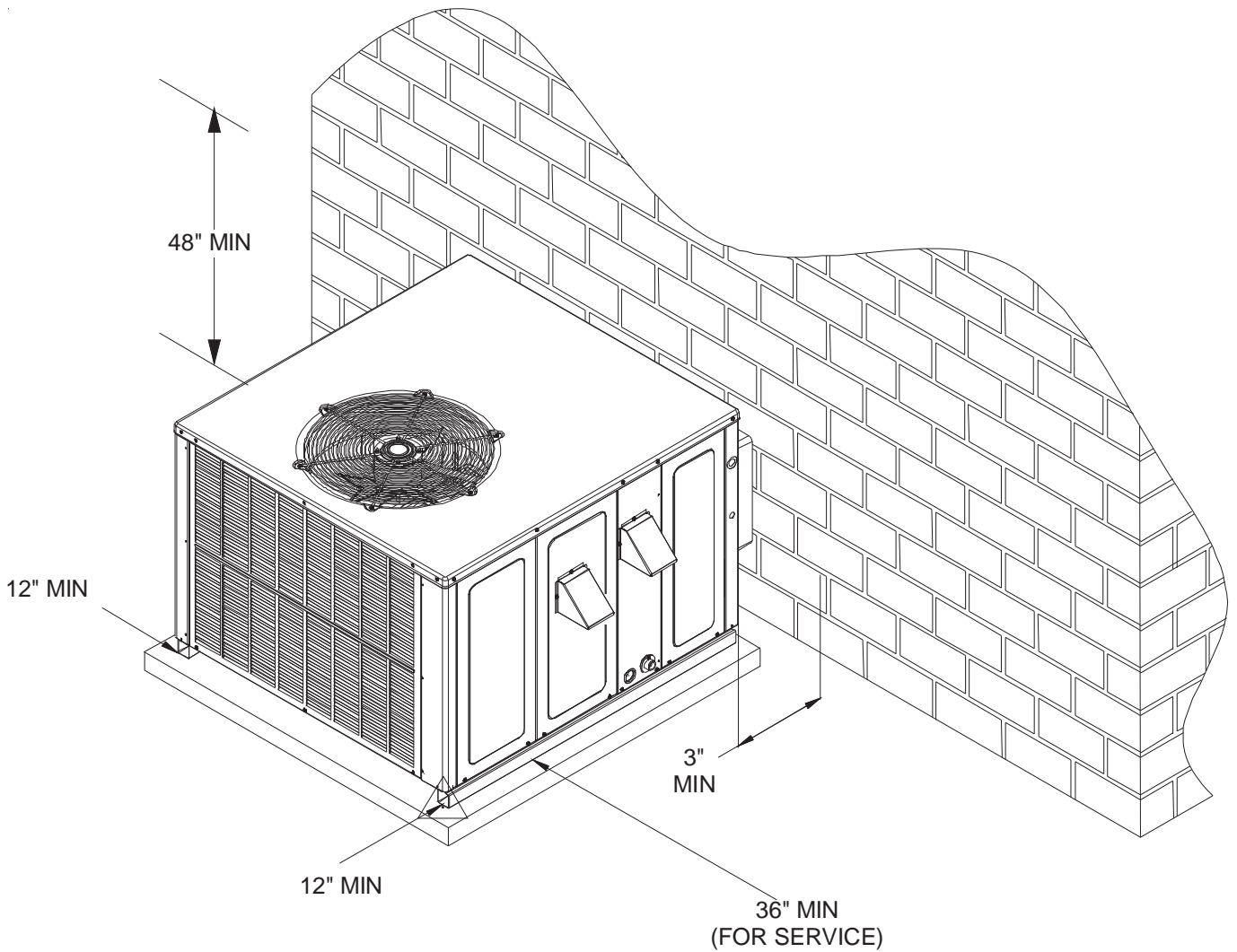

NOTE: Roof overhang should be no more than 36".

UNIT	2 Ton	2 1/2 Ton	3 Ton	3 1/2- 4 Ton	5 Ton
Min. Filter Size	(1)20 x 20 x 1	(1)20 x 25 x 1	(1)25 x 25 x 1	(2)20 x 20 x 1	(2)20 x 25 x 1

RECOMMENDED FILTER SIZES

PACKAGE UNITS - DUAL FUEL & GAS

HOMEOWNER'S ROUTINE MAINTENANCE RECOMMENDATIONS

We strongly recommend a bi-annual maintenance checkup be performed by a **qualified service agency** before the heating and cooling seasons begin.

 **WARNING**

HIGH VOLTAGE!
DISCONNECT ALL POWER BEFORE PERFORMING ANY SERVICE OR MAINTENANCE ON THIS UNIT. MULTIPLE POWER SOURCES MAY BE PRESENT. FAILURE TO DO SO MAY CAUSE PROPERTY DAMAGE, PERSONAL INJURY OR DEATH.



ANNUAL INSPECTION (QUALIFIED SERVICER ONLY)

Your package unit should be inspected by a qualified installer, or service agency at least twice every year. This check should be performed before the heating and cooling seasons begin. This will ensure that adequate combustion air is being drawn and the vent system is working properly. Particular attention should be paid to the following items. Repair as necessary.

- Check physical support of the unit. Ensure it is sound without any sagging, cracks, or gaps, around the base.
- Check for obvious signs of deterioration of the unit.
- Flue Hood and Combustion Air Inlet. Check for blockage (wasp nest, etc.) and corrosion.

FLUE HOOD (QUALIFIED SERVICER ONLY)

- Return Air Connection. Check for physical soundness and ensure that the connection is firmly sealed to the package unit casing.
- Heat exchanger. Check for corrosion and/or obstructions within the heat exchanger passageways.
- Burners. Check for proper ignition, burner flame, and flame sense.
- Wiring. Check wires for damage. Check electrical connections for tightness and/or corrosion.
- Filters. Check that filters are clean and in the proper placement in the unit or duct system.
- Louvers. Inspect air inlet louvers inside the heat exchanger compartments. Ensure the area is clean and free of dirt and debris.

Clean Outside Coil (Qualified Servicer Only)

The outdoor coil should be inspected annually. It is important to keep the outdoor coil clean. Dirt, leaves, or debris could restrict the airflow. If cleaning of the outdoor coil becomes necessary, hire a qualified servicer. Inexperienced people could easily puncture the tubing in the coil.

REPLACE OR CLEAN FILTER

IMPORTANT NOTE: Never operate unit without a filter installed as dust and lint will build up on internal parts resulting in loss of efficiency, equipment damage and possible fire.

A return air filter is not supplied with this unit; however, there must be a means of filtering the return air. An indoor air filter must be used with your comfort system. A properly maintained filter will keep the indoor coil of your comfort system clean. A dirty coil could cause poor operation and/or severe equipment damage.

The installer of your unit can tell you where your filter(s) are and how to clean or replace them.

Check your return filter(s) at least once every two months. When they are dirty, replace or clean as required. Disposable type filters should be replaced. Reusable type filters may be cleaned.

NOTE: Reusable type filters should be washed with warm water, dried completely and sprayed with an adhesive according to the manufacturers recommendations.

You may want to ask your dealer about high efficiency filters. High efficiency filters are available in both electronic and non-electronic types. These filters can do a better job of catching small airborne particles.

Improper filter maintenance is the most common cause of inadequate heating or cooling performance. Filters should be cleaned (permanent) or replaced (disposable) every two months or as required. When replacing a filter, it must be replaced with a filter of the same type and size and always make certain the air flow arrows on the filter point in the proper direction.

CONDENSER, EVAPORATOR AND INDUCED DRAFT MOTORS

The bearings on the air circulating blower motor, condenser motor and the combustion fan motor are permanently lubricated and require no further lubrication.

COMPRESSOR

The compressor motor is hermetically sealed and does not require additional oiling.

BEFORE CALLING YOUR SERVICER

- Check the thermostat to confirm that it is properly set.
- Check the disconnect switch near the unit to confirm that it is closed.
- Check the electrical panel for tripped circuit breakers or failed fuses. Reset the circuit breakers or replace fuses as necessary.
- Check for blockage of the indoor air inlets and outlets. Confirm that they are open and have not been blocked by objects (rugs, curtains or furniture).
- Check for obstructions on the unit. Confirm that it has not been covered on the sides or the top. Remove any obstruction that can be safely removed. If the unit is covered with dirt or debris, call a qualified servicer to clean it.
- Check the filter. If it is dirty, clean or replace it.