

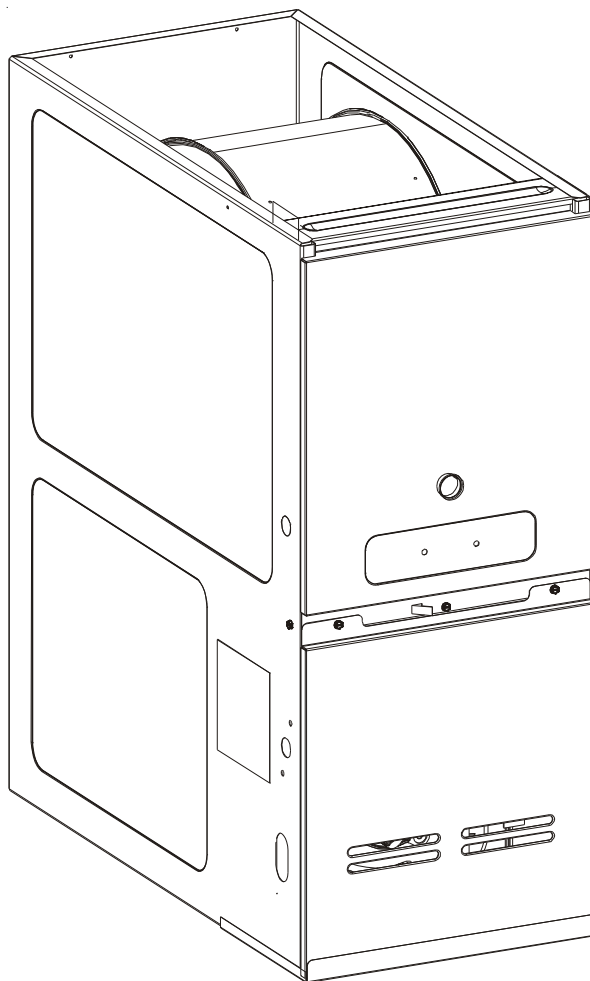

TECHNICAL MANUAL

GDS8 & GHS8 33-3/8" 80% Gas Furnace Units

- Refer to Service Manual RS6610004 for installation, operation, and troubleshooting information.
- All safety information must be followed as provided in the Service Manual.
- Refer to the appropriate Parts Catalog for part number information.
- Model numbers listed on page 3.



This manual is to be used by qualified, professionally trained HVAC technicians only. Goodman does not assume any responsibility for property damage or personal injury due to improper service procedures or services performed by an unqualified person.

RT6622013r2
March 2013

PRODUCT IDENTIFICATION

The model and manufacturing number are used for positive identification of component parts used in manufacturing. Please use these numbers when requesting service or parts information.

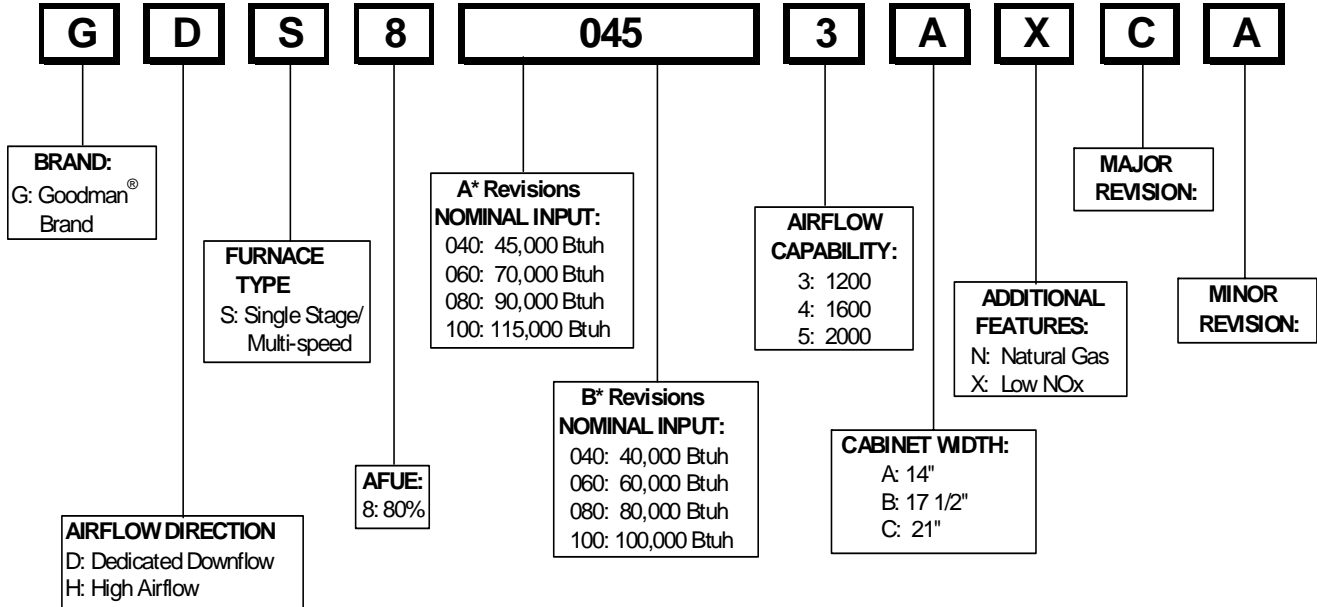

WARNING

HIGH VOLTAGE!

Disconnect ALL power before servicing or installing this unit. Multiple power sources may be present. Failure to do so may cause property damage, personal injury or death.

WARNING

Goodman will not be responsible for any injury or property damage arising from improper service or service procedures. If you install or perform service on this unit, you assume responsibility for any personal injury or property damage which may result. Many jurisdictions require a license to install or service heating and air conditioning equipment.

WARNING

Installation and repair of this unit should be performed ONLY by individuals meeting the requirements (at a minimum) of an "entry level technician" as specified by the Air-Conditioning, Heating, and Refrigeration Institute (AHRI). Attempting to install or repair this unit without such background may result in product damage, personal injury or death.

PRODUCT IDENTIFICATION

The model and manufacturing number are used for positive identification of component parts used in manufacturing. Please use these numbers when requesting service or parts information.

GDS80403A*A*

GDS80403A*B*

GDS80603A*A*

GDS80603A*B*

GDS80804B*A*

GDS80804B*B*

GDS81005C*A*

GDS81005C*B*

GHS80403A*A*

GHS80403A*B*

GHS80604A*A*

GHS80604A*B*

GHS80805C*A*

GHS80805C*B*

** These models available in Natural Gas and Low NOx*



The United States Environmental Protection Agency ("EPA") has issued various regulations regarding the introduction and disposal of refrigerants introduced into this unit. Failure to follow these regulations may harm the environment and can lead to the imposition of substantial fines. These regulations may vary by jurisdiction. Should questions arise, contact your local EPA office.



Do not connect or use any device that is not design certified by Goodman for use with this unit. Serious property damage, personal injury, reduced unit performance and/or hazardous conditions may result from the use of such non-approved devices.



To prevent the risk of property damage, personal injury, or death, do not store combustible materials or use gasoline or other flammable liquids or vapors in the vicinity of this appliance.

PRODUCT DESIGN

General Operation

The G*S8 furnaces are equipped with an electronic ignition device used to light the burners and an induced draft blower to exhaust combustion products.

An interlock switch prevents furnace operation if the inner blower door is not in place. Keep the blower access door in place except for inspection and maintenance. (See illustration on pages 5 and 6.)

This furnace is also equipped with a self-diagnosing electronic control module. In the event a furnace component is not operating properly, the control module LED will flash on and off in a factory-programmed sequence, depending on the problem encountered. This light can be viewed through the observation window in the blower access door. Refer to the *Troubleshooting Chart* for further explanation of the LED codes and *Abnormal Operation - Integrated Ignition Control* section in the Service Instructions for an explanation of the possible problem.

The rated heating capacity of the furnace should be greater than or equal to the total heat loss of the area to be heated. The total heat loss should be calculated by an approved method or in accordance with "ASHRAE Guide" or "Manual J-Load Calculations" published by the Air Conditioning Contractors of America.

*Obtain from: American National Standards Institute 1430 Broadway New York, NY 10018

Location Considerations

- The furnace should be as centralized as is practical with respect to the air distribution system.
- Do not install the furnace directly on carpeting, tile, or combustible material other than wood flooring.
- When installed in a residential garage, the furnace must be positioned so the burners and ignition source are located not less than 18 inches (457 mm) above the floor and protected from physical damage by vehicles.

Notes:

 WARNING
<p>TO PREVENT POSSIBLE PERSONAL INJURY OR DEATH DUE TO ASPHYXIATION, THIS FURNACE MUST BE CATEGORY I VENTED. DO NOT VENT USING CATEGORY III VENTING.</p>

Category I Venting is venting at a non-positive pressure. A furnace vented as Category I is considered a fan-assisted appliance and the vent system does not have to be "gas tight." **NOTE:** Single stage gas furnaces with induced draft blowers draw products of combustion through a heat exchanger allowing, in some instances, common venting with natural draft appliances (i.e. water heaters). All installations must be vented in accordance with National Fuel Gas Code

NFPA 54/ANSI Z223.1 - latest edition. In Canada, the furnaces must be vented in accordance with the National Standard of Canada, CAN/CSA B149.1 and CAN/CSA B149.2 - latest editions and amendments.

NOTE: The vertical height of the Category I venting system must be at least as great as the horizontal length of the venting system.

Accessibility Clearances (Minimum)

Unobstructed front clearance of 24" **for servicing** is recommended.

MINIMUM CLEARANCE TO COMBUSTIBLE MATERIALS - INCHES

Sides	Rear	Front*	Vent		Top
			SW	B	
1	0	3	6	1	1

* 24" clearance for serviceability recommended.

** Single Wall Vent (SW) to be used only as a connector.

Refer to the venting tables outlined in the Installation Manual for additional venting requirements.

Note: In all cases accessibility clearance shall take precedence over clearances from the enclosure where accessibility clearances are greater. All dimensions are given in inches.

High Altitude Derate

IMPORTANT NOTE: The furnace as shipped requires no change to run between 0 - 4500 feet. Do not attempt to increase the firing rate by changing orifices or increasing the manifold pressure below 4500 feet. This can cause poor combustion and equipment failure.

High altitude installations above 4500 feet may require both a pressure switch and an orifice change. These changes are necessary to compensate for the natural reduction in the density of both the gas fuel and the combustion air at higher altitude.

For installations above 4500 feet, please refer to your distributor for required kit(s). Contact the distributor for a tabular listing of appropriate manufacturer's kits for propane gas and/or high altitude installations. The indicated kits must be used to insure safe and proper furnace operation. All conversions must be performed by a qualified installer, or service agency.

PRODUCT DIMENSIONS

GHS8

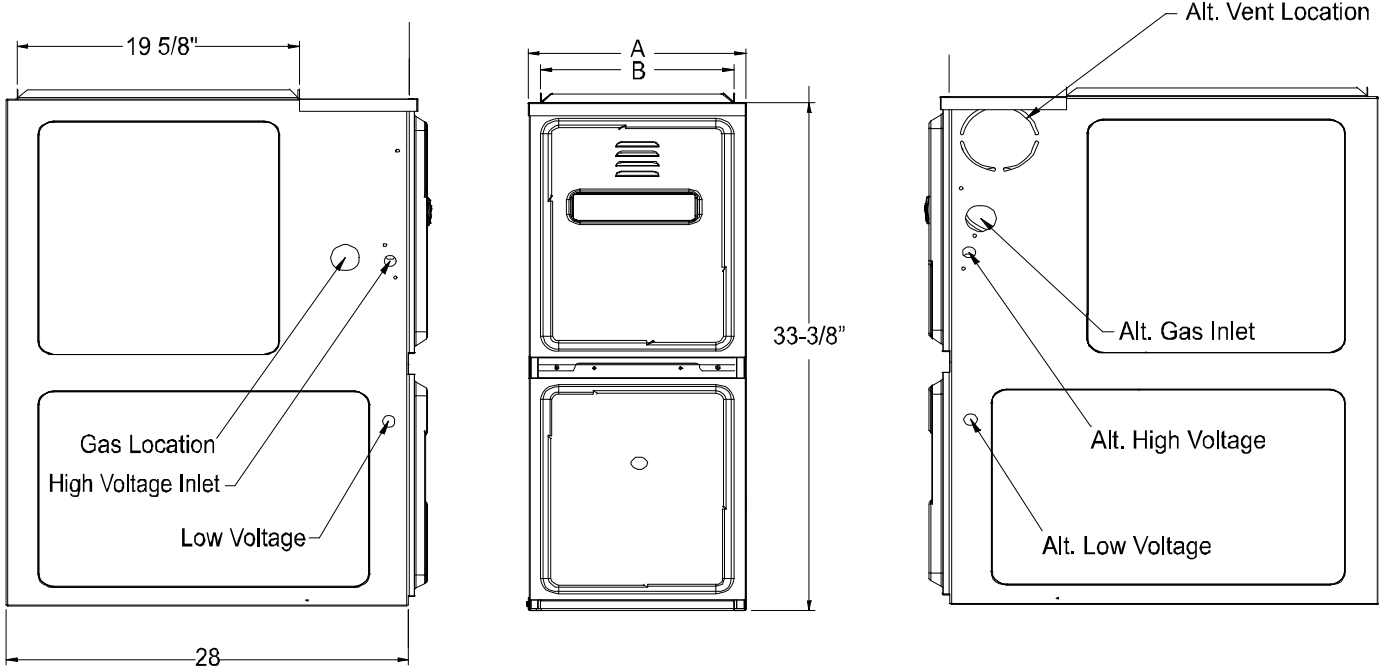

MODEL	A	B
GHS80403A***	14 1/2"	12 1/2"
GHS80604B***	17 1/2"	16"
GHS80805C***	21"	19 1/2"

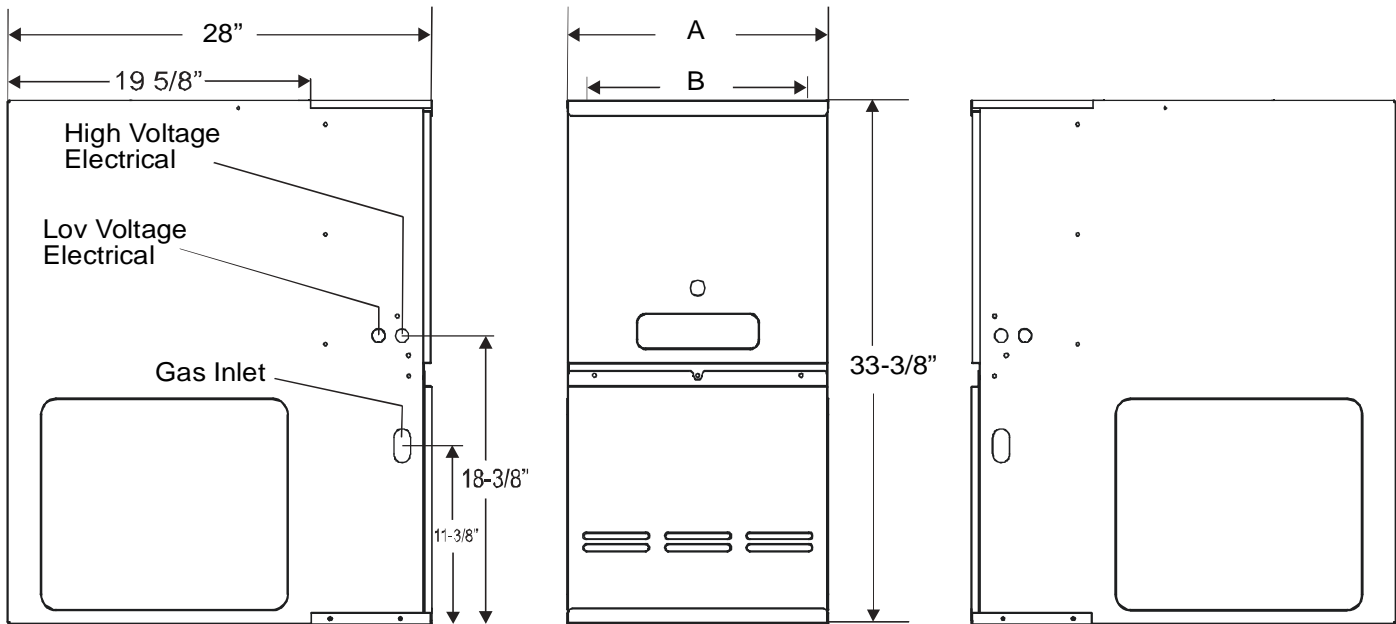

MODEL	A	B
GDS80403A***	14 1/2"	12 1/2"
GDS80603A***	14 1/2"	12 1/2"
GDS80804B***	17 1/2"	16"
GDS81005C***	21"	19 1/2"

PRESSURE SWITCH TRIP POINTS AND USAGE CHART		
Model	Trip Point ID Blower Pressure Switch	ID Blower Pressure Switch Part #
GHS80403A*A*	-0.80	0130F00042
GHS80604B*A*	-0.70	B1370158
GHS80805C*A*	-0.70	B1370158

For installations in Canada, the GHS furnaces are certified only to 4,500 ft.

* Negative pressure readings are in inches of water column (*w.c.)

PRIMARY LIMIT		
Part Number	0130M00063	20162903
Open Setting (°F)	140	160
GHS80403A*A*	1	---
GHS80604B*A*	---	1
GHS80805C*A*	1	---

ROLLOUT LIMIT SWITCHES	
Part Number	10123529
Open Setting (°F)	300
GHS80403A***	2
GHS80604B***	2
GHS80805C***	2

AUXILIARY LIMIT SWITCHES	
Part Number	0130F00038
Open Setting (°F)	120
GHS80403A***	1
GHS80604B***	1
GHS80805C***	1

PRESSURE SWITCH TRIP POINTS AND USAGE CHART		
Model	Trip Point ID Blower Pressure Switch	ID Blower Pressure Switch Part #
GHS80403A*B*	-0.70	B1370158
GHS80604B*B*	-0.80	0130F00042
GHS80805C*B*	-0.75	B1370179

For installations in Canada, the GHS furnaces are certified only to 4,500 ft.

* Negative pressure readings are in inches of water column (*w.c.)

PRIMARY LIMIT		
Part Number	0130M00063	20162903
Open Setting (°F)	140	160
GHS80403A*B*	---	1
GHS80604B*B*	1	---
GHS80805C*B*	1	---

ROLLOUT LIMIT SWITCHES	
Part Number	10123529
Open Setting (°F)	300
GHS80403A***	2
GHS80604B***	2
GHS80805C***	2

AUXILIARY LIMIT SWITCHES	
Part Number	0130F00038
Open Setting (°F)	120
GHS80403A***	1
GHS80604B***	1
GHS80805C***	1

PRESSURE SWITCHES		
Model	Part No.	Opens*
GDS80403A*A*	B1370142	-0.60
GDS80603A*A*	B1370158	-0.70
GDS80804B*A*	B1370142	-0.60
GDS81005C*A*	B1370158	-0.70

PRIMARY LIMIT		
Part Number	0130F00035	0130F00036
Open Setting (°F)	220	180
GDS80403A*A*	1	---
GDS80603A*A*	1	---
GDS80804B*A*	---	1
GDS81005C*A*	---	1

ROLLOUT LIMIT SWITCHES	
Part Number	10123529
Open Setting (°F)	300
GDS80403A***	1
GDS80603A***	1
GDS80804B***	1
GDS81005C***	1

AUXILIARY LIMIT SWITCHES	
Part Number	0130F00038
Open Setting (°F)	120
GDS80403A***	1
GDS80603A***	1
GDS80804B***	1
GDS81005C***	1

PRESSURE SWITCHES		
Model	Part No.	Opens*
GDS80403A*B*	B1370142	-0.60
GDS80603A*B*	B1370142	-0.60
GDS80804B*B*	B1370142	-0.60
GDS81005C*B*	0130F00042	-0.80

PRIMARY LIMIT		
Part Number	20162901	0130F00036
Open Setting (°F)	210	180
GDS80403A*B*	---	1
GDS80603A*B*	---	1
GDS80804B*B*	---	1
GDS81005C*B*	1	---

ROLLOUT LIMIT SWITCHES	
Part Number	10123529
Open Setting (°F)	300
GDS80403A***	1
GDS80603A***	1
GDS80804B***	1
GDS81005C***	1

AUXILIARY LIMIT SWITCHES	
Part Number	0130F00038
Open Setting (°F)	120
GDS80403A***	1
GDS80603A***	1
GDS80804B***	1
GDS81005C***	1

PRODUCT DESIGN

Coil Matches:

A large array of Amana® brand coils are available for use with the GHS8 furnaces, in horizontal applications and for the GDS8 for downflow applications. These coils are available in both cased and uncased models (with the option of a field installed TXV expansion device). These 80% furnaces match up with the existing Amana® brand coils as shown below.

Coil Matches (for Goodman® units using R22 and R-410A):

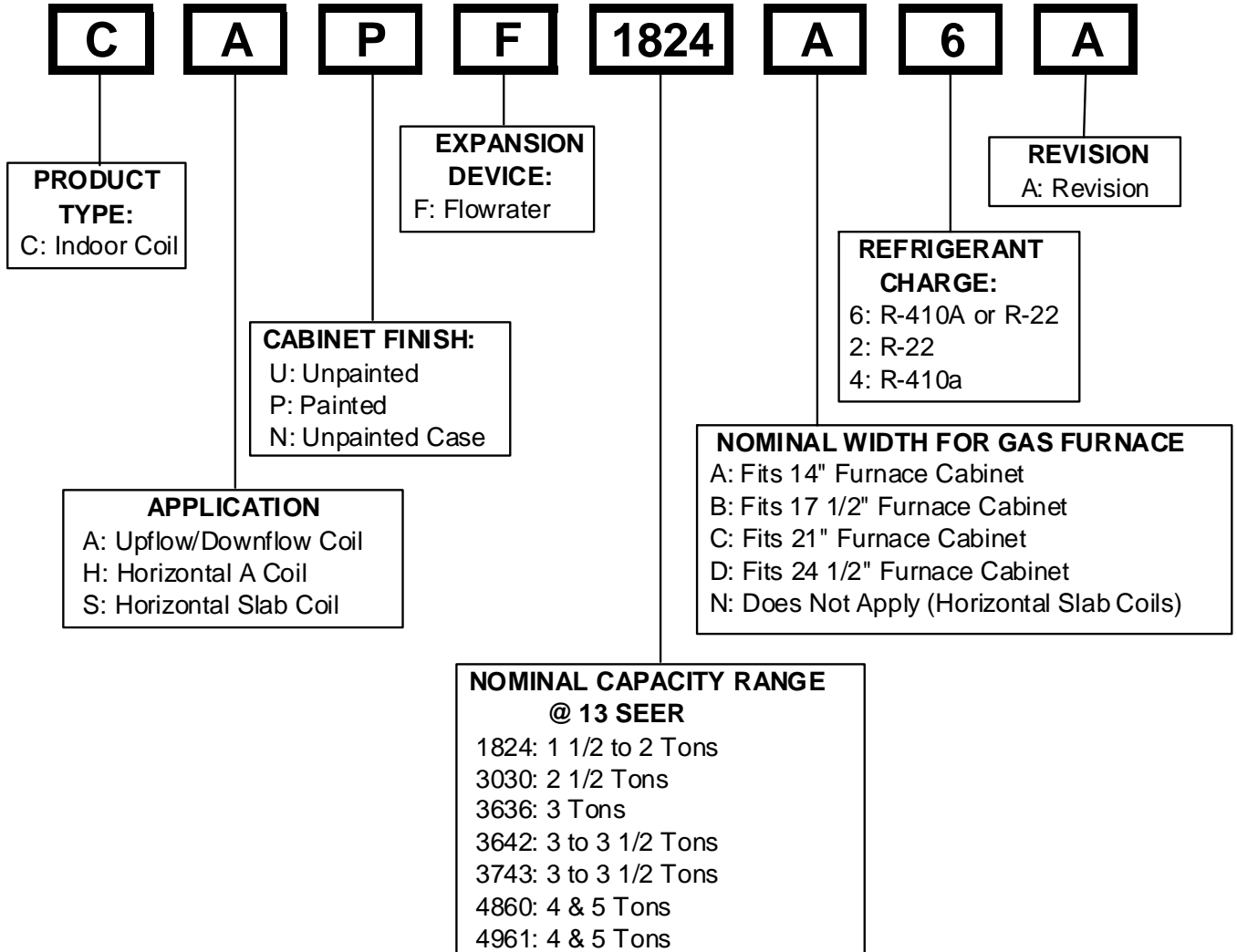

- All CAPF coils in B, C, & D widths have insulated blank off plates for use with one size smaller furnaces.
- All CAPF coils have a CAUF equivalent.
- All CHPF coils in B, C & D heights have an insulated Z bracket for use with one size smaller furnace.
- All proper coil combinations are subject to being AHRI rated with a matched outdoor unit.

PRODUCT DESIGN

Thermostats:

NOTE: Complete lineup of thermostats can be found in the Thermostat Specification Sheets.

Filters:

Filters are required with this furnace and must be provided by the installer. The filters used must comply with UL900 or CAN/ULCS111 standards. Installing this furnace without filters will void the unit warranty

Upflow Filters

This furnace has provisions for the installation of return air filters at the side and/or bottom return. The furnace will accommodate the following filter sizes depending on cabinet size:

SIDE RETURN		
Cabinet Width (in.)	Nominal Filter Size (in.)	Approx. Flow Area (in ²)
All	16 x 25 x 1	400

BOTTOM RETURN		
Cabinet Width (in.)	Nominal Filter Size (in.)	Approx. Flow Area (in ²)
17-1/2	14 x 25 x 1	350
21	16 x 25 x 1	400
24-1/2	20 x 25 x 1	500

Refer to Minimum Filter Area tables to determine filter area requirement. **NOTE:** Filters can also be installed elsewhere in the duct system such as a central return.

		UPFLOW COOLING AIRFLOW REQUIREMENT (CFM)						
		600	800	1000	1200	1400	1600	2000
Input_Airflow	0604__XA	---	---	564*	564*	672	768	---
	0805__XA	---	---	---	752*	752*	768	960
	1005__XA	---	---	---	940*	940*	940*	960

		UPFLOW COOLING AIRFLOW REQUIREMENT (CFM)						
		600	800	1000	1200	1400	1600	2000
Input_Airflow	0604__XA	---	---	627*	627*	672	768	---
	0805__XA	---	---	---	836*	836*	836*	960
	1005__XA	---	---	---	940*	940*	940*	960

		COUNTERFLOW COOLING AIRFLOW REQUIREMENT (CFM)						
		600	800	1000	1200	1400	1600	2000
Input_Airflow	0604__XA	---	---	641*	641*	672	768	---
	0805__XA	---	---	---	854*	854*	854*	960

		COUNTERFLOW COOLING AIRFLOW REQUIREMENT (CFM)						
		600	800	1000	1200	1400	1600	2000
Input_Airflow	0604__XA	---	---	320*	320*	336	384	---
	0805__XA	---	---	---	427*	427*	427*	480

*Minimum filter area dictated by heating airflow requirement.

*Minimum filter area dictated by heating airflow requirement.

Disposable Minimum Filter Area (in²)
[Based on a 300 ft/min filter face velocity]

Permanent Minimum Filter Area (in²)
[Based on 600 ft/min filter face velocity]

PRODUCT DESIGN

Counterflow Filters

This furnace has provisions for the installation of return air filters at the counterflow top return. The furnace will accommodate the following filter sizes depending on cabinet size:

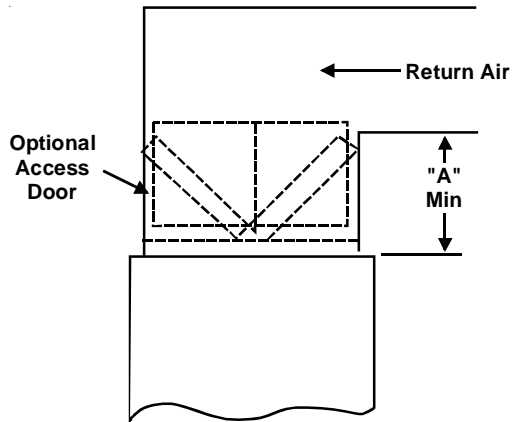

Counterflow Top Return				
Cabinet Width	Filter Area (in ²)	Qty	Filter Size (in)	Dimension "A" (in)
21	600	2	15 X 20 X 1	13.0
24 1/2				11.3
21	800	2	20 X 20 X 1	18.8
24 1/2				17.7
21	1000	2	25 X 20 X 1	24.3
24 1/2				23.4

Refer to Minimum Filter Area tables to determine filter area requirement. **NOTE:** Filters can also be installed elsewhere in the duct system such as a central return.

FURNACE SPECIFICATIONS

GDS8***A*

MODEL	GDS80403A*A*	GDS80603A*A*	GDS80804B*A*	GDS81005C*A*
Btuh Input (US) High Fire ⁽¹⁾	45,000	70,000	90,000	115,000
Output (US) High Fire ⁽¹⁾	36,000	56,000	72,000	92,000
A.F.U.E. ⁽²⁾	80%	80%	80%	80%
Rated External Static (" w.c.)	.20 - .50	.20 - .50	.20 - .50	.20 - .50
Temperature Rise (°F)	35-65	30-60	35-65	40 - 70
Pressure Switch Trip Point (" w.c.)	-0.60	-0.70	-0.60	-0.70
Blower Wheel (D" x W")	10 X 6	10 x 6	10 x 8	10 x 10
Blower Horsepower	1/3	1/3	1/2	3/4
Blower Speeds Max CFM @ 0.5 E.S.P.	Refer to airflow charts.			
Power Supply	115-60-1	115-60-1	115-60-1	115-60-1
Minimum Circuit Ampacity (MCA) ⁽⁴⁾	8.5	8.5	12.9	12.9
Maximum Overcurrent Device ⁽⁵⁾	15	15	15	15
Transformer (VA)	40	40	40	40
Heat Anticipator (Amps)	0.7	0.7	0.7	0.7
Primary Limit Setting (°F)	220	220	180	180
Auxiliary Limit Setting (°F)	120	120	120	120
Rollout Limit Setting (°F)	300	300	300	300
Gas Supply Pressure (Natural/Propane) (" w.c.)	7 / 11	7 / 11	7 / 11	7 / 11
Manifold Pressure (Natural/Propane) High Stage (" w.c.)	3.5 / 10	3.5 / 10	3.5 / 10	3.5 / 10
Orifice Size (Natural/Propane)	#43 / #55	#43 / #55	#43 / #55	#43 / #55
Number of Burners	2	3	4	5
Vent Connector Diameter (inches) ⁽³⁾	4	4	4	4
Shipping Weight (lbs.)	88	92	105	113

1 Natural Gas BTU/h. For altitudes above 2,000', reduce input rating 4% for each 1,000' above sea level.

2 DOE AFUE based upon Isolated Combustion System (ICS)

3 Vent and combustion air diameters may vary depending upon vent length.

Refer to the latest editions of the National Fuel Gas Code NFPA 54/ANSI Z223.1 (in the USA) and the Canada National Standard of Canada, CAN/CSA B149.1 and CAN/CSA B142.2 (in Canada).

4 Minimum Circuit Ampacity = (1.25 x Circulator Blower Amps) + ID Blower amps. Wire size should be determined in accordance with National Electrical Codes. Extensive wire runs will require larger wire sizes.

5 Maximum Overcurrent Protection Device refers to maximum recommended fuse or circuit breaker size. May use fuses or HACR-type circuit breakers of the same size as noted.

Notes:

- All furnaces are manufactured for use on 115 VAC, 60 Hz, single-phase electrical supply.
- Gas Service Connection ½" FPT
- Important: Size fuses and wires properly and make electrical connections in accordance with the National Electrical Code and/or all existing local codes.

NOTES:

- * These furnaces are manufactured for natural gas operation. Optional Kits are available for conversion to propane gas operation.
- * For elevations above 2000 ft. the rating should be reduced by 4% for each 1000 ft. above sea level. The furnace must not be derated, orifice changes should only be made if necessary for altitude.
- * The total heat loss from the structure as expressed in TOTAL BTU/HR must be calculated by the manufactures method in accordance with the "A.S.H.R.A.E. GUIDE" or "MANUAL J-LOAD CALCULATIONS" published by the AIR CONDITIONING CONTRACTORS OF AMERICA. The total heat loss calculated should be equal to or less than the heating capacity. Output based on D.O.E. test procedures, steady state efficiency times output.

Unit specifications are subject to change without notice. **ALWAYS** refer to the unit's serial plate for the most up-to-date general and electrical information.

FURNACE SPECIFICATIONS

GDS8***B*

MODEL	GDS80403A*B*	GDS80603A*B*	GDS80804B*B*	GDS81005C*B*
Btuh Input (US) High Fire	40,000	60,000	80,000	100,000
Output (US) High Fire	32,000	48,000	64,000	80,000
A.F.U.E. ⁽¹⁾	80%	80%	80%	80%
Rated External Static (" w.c.)	.20 - .50	.20 - .50	.20 - .50	.20 - .50
Temperature Rise (°F)	25-55	30-60	35-65	40 - 70
Pressure Switch Trip Point (" w.c.)	-0.60	-0.60	-0.60	-0.80
Blower Wheel (D" x W")	10 X 6	10 x 6	10 x 8	10 x 10
Blower Horsepower	1/3	1/3	1/2	3/4
Blower Speeds Max CFM @ 0.5 E.S.P.	Refer to airflow charts.			
Power Supply	115-60-1	115-60-1	115-60-1	115-60-1
Minimum Circuit Ampacity (MCA) ⁽³⁾	8.5	8.5	12.9	12.9
Maximum Overcurrent Device ⁽⁴⁾	15	15	15	15
Transformer (VA)	40	40	40	40
Heat Anticipator (Amps)	0.7	0.7	0.7	0.7
Primary Limit Setting (°F)	180	180	180	210
Auxiliary Limit Setting (°F)	120	120	120	120
Rollout Limit Setting (°F)	300	300	300	300
Gas Supply Pressure (Natural/Propane) (" w.c.)	7 / 11	7 / 11	7 / 11	7 / 11
Manifold Pressure (Natural/Propane) High Stage (" w.c.)	3.5 / 10	3.5 / 10	3.5 / 10	3.5 / 10
Orifice Size (Natural/Propane)	#45 / #55	#45 / #55	#45 / #55	#45 / #55
Number of Burners	2	3	4	5
Vent Connector Diameter (inches) ⁽²⁾	4	4	4	4
Shipping Weight (lbs.)	88	92	105	113

1 DOE AFUE based upon Isolated Combustion System (ICS)

2 Vent and combustion air diameters may vary depending upon vent length.

Refer to the latest editions of the National Fuel Gas Code NFPA 54/ANSI Z223.1 (in the USA) and the Canada National Standard of Canada, CAN/CSA B149.1 and CAN/CSA B142.2 (in Ca)

3 Minimum Circuit Ampacity = (1.25 x Circulator Blower Amps) + ID Blower amps. Wire size should be determined in accordance with National Electrical Codes. Extensive wire runs will require larger wire sizes.

4 Maximum Overcurrent Protection Device refers to maximum recommended fuse or circuit breaker size. May use fuses or HACR-type circuit breakers of the same size as noted.

Notes:

- All furnaces are manufactured for use on 115 VAC, 60 Hz, single-phase electrical supply.
- Gas Service Connection ½" FPT
- Important: Size fuses and wires properly and make electrical connections in accordance with the National Electrical Code and/or all existing local codes.

NOTES:

- * These furnaces are manufactured for natural gas operation. Optional Kits are available for conversion to propane gas operation.
- * The total heat loss from the structure as expressed in TOTAL BTU/HR must be calculated by the manufactures method in accordance with the "A.S.H.R.A.E. GUIDE" or "MANUAL J-LOAD CALCULATIONS" published by the AIR CONDITIONING CONTRACTORS OF AMERICA. The total heat loss calculated should be equal to or less than the heating capacity. Output based on D.O.E. test procedures, steady state efficiency times output.

Unit specifications are subject to change without notice. **ALWAYS** refer to the unit's serial plate for the most up-to-date general and electrical information.

FURNACE SPECIFICATIONS

GHS8***A*

MODEL	GHS80403A*A*	GHS80604B*A*	GHS80805C*A*
Input, Natural Gas (BTUH) ⁽¹⁾	45,000	70,000	90,000
Output, Natural Gas (BTUH) ⁽¹⁾	36,000	56,000	72,000
Output, LP (BTUH)	32,000	48,000	64,000
A.F.U.E. ⁽²⁾	80.0%	80.0%	80.0%
Rated External Static (" w.c.)	0.20 - 0.50	0.20 - 0.50	0.20 - 0.50
Temperature Rise (°F)	15 - 45	30 - 60	35 - 65
Pressure Switch Trip Point (" w.c.)	-0.80	-0.70	-0.70
Blower Wheel (D" x W")	11" x 6"	11" x 8"	11" x 10"
Blower Horsepower	1/2	3/4	3/4
Blower Speeds	Refer to airflow charts.		
Max CFM @ 0.5 E.S.P.			
Power Supply (Volts/Hz/Ph)	115/60/1	115/60/1	115/60/1
Minimum Circuit Ampacity (MCA) ⁽⁴⁾	12.5	11.8	11.8
Maximum Overcurrent Device ⁽⁵⁾	15	15	15
Transformer (VA)	40	40	40
ID Blower Pressure Switch Trip Point (" w.c.)	-0.80	-0.70	-0.70
Primary Limit Setting (°F)	140	120	140
Auxiliary Limit Setting (°F)	120	120	120
Rollout Limit Setting (°F)	300	300	300
Gas Supply Pressure (Natural/Propane) (" w.c.)	7 / 11	7 / 11	7 / 11
Manifold Pressure (Natural/Propane) (" w.c.)	3.5 / 10	3.5 / 10	3.5 / 10
Orifice Size (Natural/Propane)	#43 / #55	#43 / #55	#43 / #55
Number of Burners	2	3	4
Vent Connector Diameter (inches) ⁽³⁾	4	4	4
Shipping Weight (lbs.)	90	102	117

1 Natural Gas BTU/h. For altitudes above 2,000', reduce input rating 4% for each 1,000' above sea level.

2 DOE AFUE based upon Isolated Combustion System (ICS)

3 Vent and combustion air diameters may vary depending upon vent length.

Refer to the latest editions of the National Fuel Gas Code NFPA 54/ANSI Z223.1 (in the USA) and the Canada National Standard of Canada, CAN/CSA B149.1 and CAN/CSA B142.2 (in Canada).

4 Minimum Circuit Ampacity = (1.25 x Circulator Blower Amps) + ID Blower amps. Wire size should be determined in accordance with National Electrical Codes. Extensive wire runs will require larger wire sizes.

5 Maximum Overcurrent Protection Device refers to maximum recommended fuse or circuit breaker size. May use fuses or HACR-type circuit breakers of the same size as noted.

Notes:

- All furnaces are manufactured for use on 115 VAC, 60 Hz, single-phase electrical supply.
- Gas Service Connection ½" FPT
- Important: Size fuses and wires properly and make electrical connections in accordance with the National Electrical Code and/or all existing local codes.

NOTES:

- * These furnaces are manufactured for natural gas operation. Optional Kits are available for conversion to propane gas operation.
- * For elevations above 2000 ft. the rating should be reduced by 4% for each 1000 ft. above sea level. The furnace must not be derated, orifice changes should only be made if necessary for altitude.
- * The total heat loss from the structure as expressed in TOTAL BTU/HR must be calculated by the manufactures method in accordance with the "A.S.H.R.A.E. GUIDE" or "MANUAL J-LOAD CALCULATIONS" published by the AIR CONDITIONING CONTRACTORS OF AMERICA. The total heat loss calculated should be equal to or less than the heating capacity. Output based on D.O.E. test procedures, steady state efficiency times output.

Unit specifications are subject to change without notice. **ALWAYS** refer to the unit's serial plate for the most up-to-date general and electrical information.

FURNACE SPECIFICATIONS

GHS8***B*

MODEL	GHS80403A*B*	GHS80604B*B*	GHS80805C*B*
Input, Natural Gas (BTUH)	40,000	60,000	80,000
Output, Natural Gas (BTUH)	32,000	48,000	64,000
Output, LP (BTUH)	32,000	48,000	64,000
A.F.U.E. ⁽¹⁾	80.0%	80.0%	80.0%
Rated External Static (" w.c.)	0.20 - 0.50	0.20 - 0.50	0.20 - 0.50
Temperature Rise (°F)	20-50	20-50	35 - 65
Pressure Switch Trip Point (" w.c.)	-0.70	-0.80	-0.75
Blower Wheel (D" x W")	11" x 6"	11" x 8"	11" x 10"
Blower Horsepower	1/2	3/4	3/4
Blower Speeds	Refer to airflow charts.		
Max CFM @ 0.5 E.S.P.	Refer to airflow charts.		
Power Supply (Volts/Hz/Ph)	115/60/1	115/60/1	115/60/1
Minimum Circuit Ampacity (MCA) ⁽³⁾	12.5	11.8	11.8
Maximum Overcurrent Device ⁽⁴⁾	15	15	15
Transformer (VA)	40	40	40
ID Blower Pressure Switch Trip Point (" w.c.)	-0.70	-0.80	-0.75
Primary Limit Setting (°F)	160	140	140
Auxiliary Limit Setting (°F)	120	120	120
Rollout Limit Setting (°F)	300	300	300
Gas Supply Pressure (Natural/Propane) (" w.c.)	7 / 11	7 / 11	7 / 11
Manifold Pressure (Natural/Propane) (" w.c.)	3.5 / 10	3.5 / 10	3.5 / 10
Orifice Size (Natural/Propane)	#45 / #55	#45 / #55	#45 / #55
Number of Burners	2	3	4
Vent Connector Diameter (inches) ⁽²⁾	4	4	4
Shipping Weight (lbs.)	90	102	117

1 DOE AFUE based upon Isolated Combustion System (ICS)

2 Vent and combustion air diameters may vary depending upon vent length.

Refer to the latest editions of the National Fuel Gas Code NFPA 54/ANSI Z223.1 (in the USA) and the Canada National Standard of Canada, CAN/CSA B149.1 and CAN/CSA B142.2 (in Ca

3 Minimum Circuit Ampacity = (1.25 x Circulator Blower Amps) + ID Blower amps. Wire size should be determined in accordance with National Electrical Codes. Extensive wire runs will require larger wire sizes.

4 Maximum Overcurrent Protection Device refers to maximum recommended fuse or circuit breaker size. May use fuses or HACR-type circuit breakers of the same size as noted.

Notes:

- All furnaces are manufactured for use on 115 VAC, 60 Hz, single-phase electrical supply.
- Gas Service Connection 1/2" FPT
- Important: Size fuses and wires properly and make electrical connections in accordance with the National Electrical Code and/or all existing local codes.

NOTES:

- * These furnaces are manufactured for natural gas operation. Optional Kits are available for conversion to propane gas operation.
- * The total heat loss from the structure as expressed in TOTAL BTU/HR must be calculated by the manufactures method in accordance with the "A.S.H.R.A.E. GUIDE" or "MANUAL J-LOAD CALCULATIONS" published by the AIR CONDITIONING CONTRACTORS OF AMERICA. The total heat loss calculated should be equal to or less than the heating capacity. Output based on D.O.E. test procedures, steady state efficiency times output.

Unit specifications are subject to change without notice. **ALWAYS** refer to the unit's serial plate for the most up-to-date general and electrical information.

BLOWER PERFORMANCE SPECIFICATIONS

GHS8***A*

(CFM & Temperature Rise vs. External Static Pressure)																		
Model	Motor Speed	Tons AC at 0.5" ESP	EXTERNAL STATIC PRESSURE (Inches Water Column)															
			0.1		0.2		0.3		0.4		0.5		0.6		0.7		0.8	
			CFM	RISE	CFM	RISE	CFM	RISE	CFM	RISE	CFM	RISE	CFM	RISE	CFM	RISE	CFM	RISE
GHS80403A*A*	HIGH	3.0	1739	19	1656	20	1601	21	1551	21	1513	22	1460	22.8	1413	23.6	1353	24.6
	MED	2.5	1422	23	1399	24	1378	24	1350	25	1305	26	1275	26.1	1220	27.3	1178	28.3
	MED-LO	2.0	1207	28	1213	27	1197	28	1169	29	1158	29	1131	29.5	1103	30.2	1068	31.2
	LOW	1.5	991	34	980	34	958	35	950	35	937	36	924	36.1	910	36.6	874	38.1
GHS80604B*A*	HIGH	4.0	2097	25	2068	25	2012	26	1939	27	1869	28	1795	28.9	1718	30.2	1631	31.8
	MED	3.5	1596	32	1566	33	1534	34	1492	35	1445	36	1401	37	1354	38.3	1288	40.3
	MED-LO	3.0	1380	38	1356	38	1328	39	1303	40	1274	41	1239	41.8	1192	43.5	1127	46
	LOW	3.0	1239	42	1191	44	1165	45	1133	46	1104	47	1082	47.9	1040	49.9	996	52.1
GHS80805C*A*	HIGH	5.0	2382	28	2315	29	2234	30	2158	31	2078	32	1971	33.8	1866	35.7	1762	37.8
	MED	4.0	1622	41	1603	42	1583	42	1556	43	1516	44	1482	45	1422	46.9	1359	49.1
	MED-LO	3.5	1436	46	1391	48	1387	48	1356	49	1325	50	1279	52.1	1239	53.8	1180	56.5
	LOW	3.0	1240	54	1214	55	1191	56	1157	58	1120	60	1083	61.6	1052	63.4	1025	65

NOTES:

- CFM in chart is without filter(s). Filters do not ship with this furnace, but must be provided by the installer.
- All furnaces ship as high-speed cooling. Installer must adjust blower cooling speed as needed.
- For most jobs, about 400 CFM per ton when cooling is desirable
- INSTALLATION IS TO BE ADJUSTED TO OBTAIN TEMPERATURE RISE WITHIN THE RANGE SPECIFIED ON THE RATING PLATE.
- The chart is for information only. For satisfactory operation, external static pressure must not exceed values shown on the rating plate. The shaded area indicates ranges in excess of maximum static pressure allowed when heating.
- The dashed (---) areas indicate a temperature rise not recommended for this model.
- At higher altitudes, a properly de-rated unit will have approximately the same temperature rise at a particular CFM, while ESP at the CFM will be lower.

BLOWER PERFORMANCE SPECIFICATIONS

GHS8***B*

(CFM & Temperature Rise vs. External Static Pressure)																		
Model	Motor Speed	Tons AC at 0.5" ESP	EXTERNAL STATIC PRESSURE (Inches Water Column)															
			0.1		0.2		0.3		0.4		0.5		0.6		0.7		0.8	
			CFM	RISE	CFM	RISE	CFM	RISE	CFM	RISE	CFM	RISE	CFM	RISE	CFM	RISE	CFM	RISE
GHS80403A*B*	HIGH	3.0	1739	----	1656	----	1601	----	1551	----	1513	20	1460	22.8	1413	23.6	1353	24.6
	MED	2.5	1422	21	1399	21	1378	22	1350	22	1305	23	1275	26.1	1220	27.3	1178	28.3
	MED-LO	2.0	1207	25	1213	24	1197	25	1169	25	1158	26	1131	29.5	1103	30.2	1068	31.2
	LOW	1.5	991	30	980	30	958	31	950	31	937	32	924	36.1	910	36.6	874	38.1
GHS80604B*B*	HIGH	4.0	2097	21	2068	21	2012	22	1939	23	1869	24	1795	28.9	1718	30.2	1631	31.8
	MED	3.5	1596	28	1566	28	1534	29	1492	30	1445	31	1401	37	1354	38.3	1288	40.3
	MED-LO	3.0	1380	32	1356	33	1328	33	1303	34	1274	35	1239	41.8	1192	43.5	1127	46
	LOW	3.0	1239	36	1191	37	1165	37	1133	39	1104	40	1082	47.9	1040	49.9	996	52.1
GHS80805C*B*	HIGH	5.0	2382	----	2315	----	2234	----	2158	----	2078	----	1971	33.8	1866	35.7	1762	37.8
	MED	4.0	1622	37	1603	37	1583	37	1556	38	1516	39	1482	45	1422	46.9	1359	49.1
	MED-LO	3.5	1436	41	1391	43	1387	41	1356	44	1325	45	1279	52.1	1239	53.8	1180	56.5
	LOW	3.0	1240	48	1214	49	1191	50	1157	51	1120	53	1083	61.6	1052	63.4	1025	65

NOTES:

- CFM in chart is without filter(s). Filters do not ship with this furnace, but must be provided by the installer.
- All furnaces ship as high-speed cooling. Installer must adjust blower cooling speed as needed.
- For most jobs, about 400 CFM per ton when cooling is desirable
- INSTALLATION IS TO BE ADJUSTED TO OBTAIN TEMPERATURE RISE WITHIN THE RANGE SPECIFIED ON THE RATING PLATE.
- The chart is for information only. For satisfactory operation, external static pressure must not exceed values shown on the rating plate. The shaded area indicates ranges in excess of maximum static pressure allowed when heating.
- The dashed (---) areas indicate a temperature rise not recommended for this model.
- At higher altitudes, a properly de-rated unit will have approximately the same temperature rise at a particular CFM, while ESP at the CFM will be lower.

BLOWER PERFORMANCE SPECIFICATIONS

GDS8***A*

(CFM & Temperature Rise vs. External Static Pressure)															
Model	Motor Speed	Tons AC at 0.5" ESP	EXTERNAL STATIC PRESSURE (Inches Water Column)												
			0.1		0.2		0.3		0.4		0.5		0.6	0.7	0.8
			CFM	RISE	CFM	RISE	CFM	RISE	CFM	RISE	CFM	RISE	CFM	CFM	CFM
GDS8 0403A*A*	HIGH	3.0	1353	25	1290	26	1246	27	1199	28	1149	29	1116	1116	1099
	MED	2.5	1183	28	1113	30	1098	30	1052	32	1039	32	1006	1012	969
	MED-LO	2.0	980	34	946	35	920	36	900	37	896	37	885	855	804
	LOW	1.5	778	43	762	44	738	45	746	45	738	45	717	696	678
GDS8 0603A*A*	HIGH	3.0	1290	40	1236	42	1194	43	1166	44	1176	44	1166	1108	1029
	MED	2.5	1139	46	1090	48	1035	50	1063	49	1063	49	1020	962	895
	MED-LO	2.0	962	54	927	56	925	56	941	55	909	57	877	834	779
	LOW	1.5	787	66	776	67	763	68	744	70	723	72	690	641	581
GDS8 0804B*A*	HIGH	4.0	2128	31	2063	32	2001	33	1927	35	1824	37	1726	1628	1529
	MED	3.5	1840	36	1788	37	1745	38	1689	39	1625	41	1550	1470	1364
	MED-LO	3.0	1602	42	1558	43	1543	43	1493	45	1455	46	1402	1328	1239
	LOW	2.5	1277	52	1252	53	1244	54	1229	54	1214	55	1179	1141	1079
GDS81005C*A*	HIGH	5.0	2405	35	2361	36	2250	38	2161	39	2037	42	1937	1808	1689
	MED	4.0	1880	45	1838	46	1794	47	1734	49	1677	51	1568	1510	1401
	MED-LO	3.5	1659	51	1630	52	1587	54	1537	55	1492	57	1445	1368	1287
	LOW	3.0	1472	58	1454	59	1404	61	1366	62	1326	64	1300	1228	1139

NOTES:

- CFM in chart is without filter(s). Filters do not ship with this furnace, but must be provided by the installer.
- All furnaces ship as high-speed cooling. Installer must adjust blower cooling speed as needed.
- For most jobs, about 400 CFM per ton when cooling is desirable
- INSTALLATION IS TO BE ADJUSTED TO OBTAIN TEMPERATURE RISE WITHIN THE RANGE SPECIFIED ON THE RATING PLATE.
- The chart is for information only. For satisfactory operation, external static pressure must not exceed values shown on the rating plate. The shaded area indicates ranges in excess of maximum static pressure allowed when heating.
- The dashed (---) areas indicate a temperature rise not recommended for this model.
- At higher altitudes, a properly de-rated unit will have approximately the same temperature rise at a particular CFM, while ESP at the CFM will be lower.

BLOWER PERFORMANCE SPECIFICATIONS

GDS8***B*

(CFM & Temperature Rise vs. External Static Pressure)															
Model	Motor Speed	Tons AC at 0.5" ESP	EXTERNAL STATIC PRESSURE (Inches Water Column)												
			0.1		0.2		0.3		0.4		0.5		0.6	0.7	0.8
			CFM	RISE	CFM	RISE	CFM	RISE	CFM	RISE	CFM	RISE	CFM	CFM	CFM
GDS80403A*B*	HIGH	3.0	1353	----	1290	----	1246	----	1199	25	1149	26	1116	1116	1099
	MED	2.5	1183	25	1113	27	1098	27	1052	28	1039	29	1006	1012	969
	MED-LO	2.0	980	30	946	31	920	32	900	33	896	33	885	855	804
	LOW	1.5	778	38	762	39	738	40	746	40	738	40	717	696	678
GDS80603A*B*	HIGH	3.0	1290	34	1236	36	1194	37	1166	38	1176	38	1166	1108	1029
	MED	2.5	1139	39	1090	41	1035	43	1063	42	1063	42	1020	962	895
	MED-LO	2.0	962	46	927	48	925	48	941	47	909	49	877	834	779
	LOW	1.5	787	56	776	57	763	58	744	60	723	----	690	641	581
GDS80804B*B*	HIGH	4.0	2128	----	2063	----	2001	----	1927	----	1824	----	1726	1628	1529
	MED	3.5	1840	----	1788	----	1745	----	1689	35	1625	36	1550	1470	1364
	MED-LO	3.0	1602	37	1558	38	1543	38	1493	40	1455	41	1402	1328	1239
	LOW	2.5	1277	46	1252	47	1244	48	1229	48	1214	49	1179	1141	1079
GDS81005C*B*	HIGH	5.0	2405	----	2361	----	2250	----	2161	----	2037	36	1937	1808	1689
	MED	4.0	1880	39	1838	40	1794	41	1734	43	1677	44	1568	1510	1401
	MED-LO	3.5	1659	45	1630	45	1587	47	1537	48	1492	50	1445	1368	1287
	LOW	3.0	1472	50	1454	51	1404	53	1366	54	1326	56	1300	1228	1139

NOTES:

- CFM in chart is without filter(s). Filters do not ship with this furnace, but must be provided by the installer.
- All furnaces ship as high-speed cooling. Installer must adjust blower cooling speed as needed.
- For most jobs, about 400 CFM per ton when cooling is desirable
- INSTALLATION IS TO BE ADJUSTED TO OBTAIN TEMPERATURE RISE WITHIN THE RANGE SPECIFIED ON THE RATING PLATE.
- The chart is for information only. For satisfactory operation, external static pressure must not exceed values shown on the rating plate. The shaded area indicates ranges in excess of maximum static pressure allowed when heating.
- The dashed (---) areas indicate a temperature rise not recommended for this model.
- At higher altitudes, a properly de-rated unit will have approximately the same temperature rise at a particular CFM, while ESP at the CFM will be lower.

BLOWER PERFORMANCE SPECIFICATIONS

BTU OUTPUT vs TEMPERATURE RISE CHART

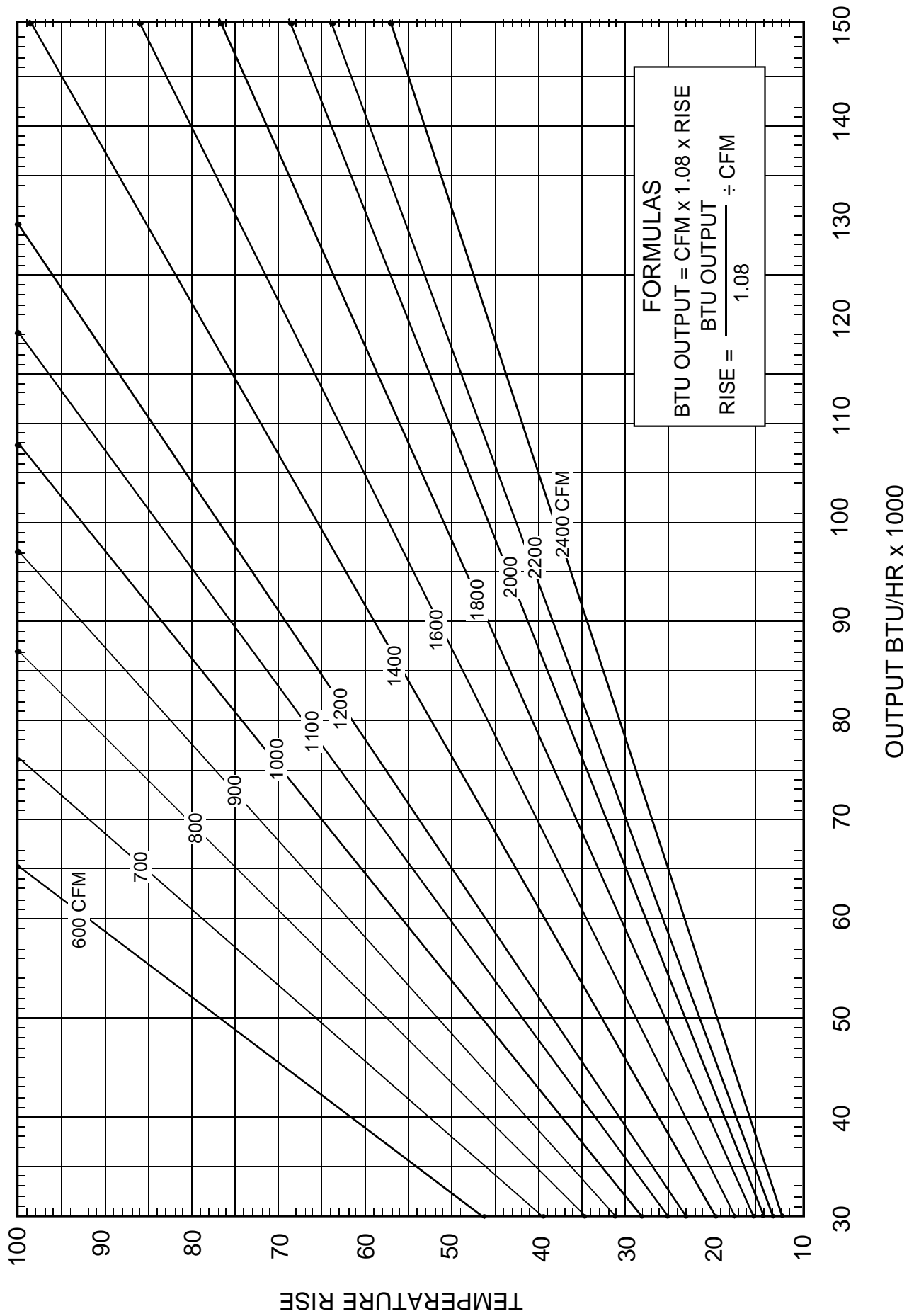



WARNING

HIGH VOLTAGE!
DISCONNECT ALL POWER BEFORE SERVICING OR INSTALLING THIS UNIT. MULTIPLE POWER SOURCES MAY BE PRESENT. FAILURE TO DO SO MAY CAUSE PROPERTY DAMAGE, PERSONAL INJURY OR DEATH.



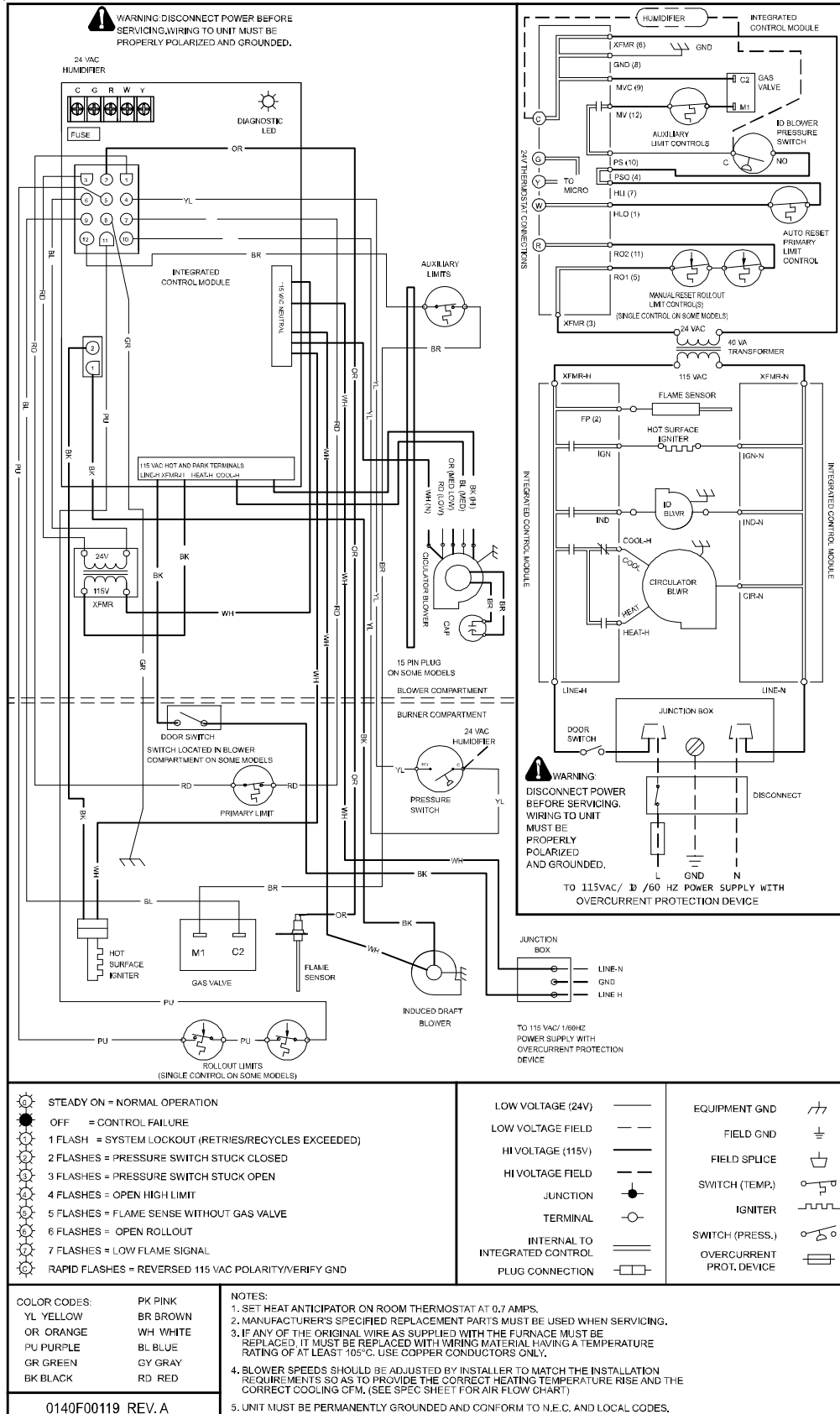

Wiring is subject to change, always refer to the wiring diagram on the unit for the most up-to-date wiring.