



141/143 SERIES

BUTTERFLY VALVE

INSTALLATION OPERATION MAINTENANCE

DOCUMENT NO.: ES-1097

REVISION LEVEL: D

ISSUED BY: Michael Conklin

DATE: 01/28/03

APPROVED BY: _____

DATE: _____

INTRODUCTION..... 3
 DESIGN FEATURES3
 OPERATING PRESSURES.....3
 PRODUCT STORAGE.....3
 PRODUCT MARKING.....4
 FIGURE 1. APOLLO® BUTTERFLY VALVE IDENTIFICATION TAG4

INSTALLATION INFORMATION..... 4
 INSTALLATION INSTRUCTIONS.....4
 FIGURE 2. VALVE IN PARTIALLY OPEN POSITION.....5
 FIGURE 3. VALVE IN FULL OPEN POSITION.....5
 MAINTENANCE AND REPAIR.....6
 TABLE 1. BUTTERFLY VALVE DISC CHORD DIMENSIONS6
 TABLE 2. STUD AND BOLT SPECIFICATION FOR LUG AND WAFER6
 FIGURE 4. FLANGE BOLT TIGHTENING SEQUENCE.....7

ASSEMBLY/DISASSEMBLY INSTRUCTIONS..... 7
 141/143 SERIES BUTTERFLY VALVE ASSEMBLY AND DISASSEMBLY7
 TABLE 3. 141/143 SERIES SEAT MATERIAL TEMPERATURE RANGES7

BUTTERFLY VALVE PART LISTS..... 8
 141/143 SERIES PARTS LIST.....8

MANUAL OPERATOR INSTALLATION..... 8
 LEVER HANDLE MOUNTING PROCEDURE8
 FIGURE 5. NOTCHPLATE INSTALLATION POSITION8
 MANUAL GEAR OPERATOR MOUNTING PROCEDURE9
 FIGURE 6. GEAR OPERATOR INSTALLATION POSITION9

AMENDMENT REGISTER..... 10

INTRODUCTION

DESIGN FEATURES

141/143 SERIES

- Available in wafer or lug body.
- Flange holes comply with ANSI Class 125/150 dimensions.
- Cast-in top plate with ISO-5211 mounting dimensions provides for direct-mounting of Apollo® CompacTorque™ actuators and manual operators.
- The face-to-face dimensions were designed to comply with MSS SP-67 and API 609.
- Wafer body features four alignment holes for ease of installation.
- Through-shaft design with taper pins connecting stem to disc. Disc-to-seat interface provides bubble-tight shut-off with reduced torque and extended service life.
- Equipped with a stretch-resistant, non-collapsible, blowout-proof, phenolic-backed cartridge seat. (14" through 24" have aluminum backing)
- Meets the intent and has passed AWWA C504-87 Section 5 proof of design tests.
- Factory tested to 110% of full rated pressure in both directions before shipping.

FLANGE AND PIPE COMPATIBILITY

APOLLO® Butterfly Valves are designed to fit between the following piping flanges:

- ANSI 125 Cast iron flanges (all sizes)
- ANSI 150 Steel flanges, schedule 40 (all sizes)
- ANSI 150 Steel flanges, schedule 80 (2"-12")

Note: When installing valves in schedule 80 piping, make sure the valve is properly centered between the pipe flanges to prevent disc edge damage since the clearance between the disc O.D. and the pipe I.D. is reduced. If there is a compatibility question, compare the minimum pipe I.D. with the disc chord dimensions in Table 1.

OPERATING PRESSURES

141/143 SERIES:

- **2"-12"** (50mm-300mm) – 200 psig (13.78 bar)
- **14"-24"** (350mm-600mm) – 150 psig (10.34 bar)

PRODUCT STORAGE

- The valves should be stored with the disc in the partially open position.
- The valves should be stored indoors in a clean, dry, well-ventilated place away from corrosive materials and protected from excessive dust and dirt.
- The valves should be stored on a rack or pallet off the floor and arranged to prevent damage during handling.
- Keep valves out of direct sunlight and in a cool location to prolong elastomer life.
- Valves should be protected to prevent damage to the flange faces, disc sealing edge and operator.

PRODUCT MARKING

All APOLLO® Butterfly Valves are equipped with an identification tag attached to the valve neck (Figure 1). This tag provides the model number, part number, size, max pressure rating, and date of manufacture.

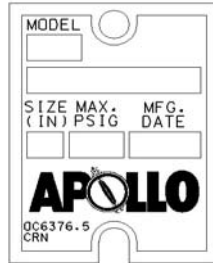

FIGURE 1. APOLLO® BUTTERFLY VALVE IDENTIFICATION TAG

INSTALLATION INFORMATION

APOLLO® butterfly valves are designed for use between the faces of ANSI 125 and 150 pound flat, raised face, slip-on or weld-neck flanges at the pressure indicated on the nameplate. **Flange gaskets should not be used.** Due to the brittle nature of cast iron, consideration should be given to the proper piping alignment prior to the installation of any cast iron lug bodied valve. All APOLLO® butterfly valves are bi-directional with the ability to control flow equally in either direction. All 141/143 Series APOLLO® lug style butterfly valves may be used for dead-end service in either direction at their full pressure rating.

INSTALLATION INSTRUCTIONS

- Step 1. Check to make sure that the pipe flange and valve sealing faces are clean and free from any debris (pipe scale, welding slag, etc.).
- Step 2. Check the valve nameplate to ensure that the pressure and valve materials are correct for the application. See Tables 3, 4, & 5 for seat material temperature ratings.

WARNING! – Apollo butterfly valves should never be installed where service conditions could exceed the valve ratings. Failure to heed warning may result in personal injury or property damage.

- Step 3. The seat sealing face on the 141/143 Series butterfly valves is wider than the valve body providing a leak-proof seal when compressed between pipe flanges. Therefore, no flange gaskets are required when installing any APOLLO® butterfly valve.
- Step 4. To prevent damage to the disc sealing edge during installation, position the disc in the “partially open” position (Figure 2) so that the disc is still contained within the valve body.

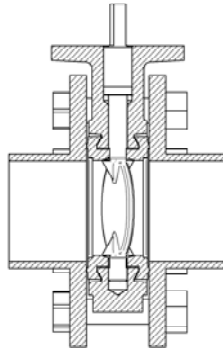

FIGURE 2. VALVE IN PARTIALLY OPEN POSITION

- Step 5. Spread the pipe flanges apart allowing the valve to be slipped easily in between the flanges.
- Step 6. Center the valve between the flanges and loosely install all the flange bolts. On the Model 141 wafer valve, the flange bolts that pass through the alignment lugs should be installed first. Consult Table 2 for correct flange bolt size and quantity.
- Step 7. Slowly open the valve to the full open position (Figure 3) and back to the partially open position ensuring that the disc moves freely without any obstruction. If no obstruction is encountered, return the valve to the full open position and hand-tighten all flange bolts using the bolt tightening sequence shown in Figure 4.

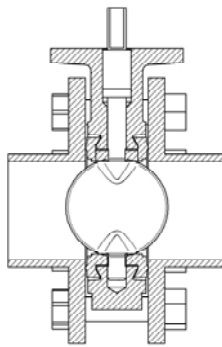

FIGURE 3. VALVE IN FULL OPEN POSITION

- Step 8. Rotate the disc from the fully open position to the fully closed position and make sure that the valve is properly centered and the disc edge does not contact the pipe ID. Return the disc to the full open position and tighten the flange bolts following the bolt tightening sequence shown in Figure 4. However, do not fully tighten each flange bolt all at once. Tighten each bolt incrementally following the sequence in Figure 4 several times until the flange bolts are tight. After all flange bolts are fully tightened, cycle the valve from full open to full closed to ensure that there is proper disc clearance.

MAINTENANCE AND REPAIR

APOLLO® butterfly valves are designed for extended service with minimal wear and servicing. No regular lubrication is required. Prior to any replacement or repair, the valve must be removed from the line following these precautions:

1. The pipeline on either side of the valve must be depressurized and drained.
2. Ensure that the disc is in the partially open or full closed position before removing the valve from the line.
3. **DO NOT** remove an actuator or operator from the valve while the line is still pressurized.

Valve Size		Disc Chord
(in)	(mm)	
2	50	1.133
2.5	65	1.706
3	80	2.450
4	100	3.488
5	125	4.296
6	150	5.697
8	200	7.468
10	250	9.484
12	300	11.456
14	350	13.000
16	400	14.970
18	450	16.847
20	500	18.650
24	600	22.558

TABLE 1. BUTTERFLY VALVE DISC CHORD DIMENSIONS

WAFER BODY HEAVY HEX BOLTS & NUTS WITH NC THREAD					LUG BODY REGULAR HEX HEAD SCREWS WITH NC THREADS		
Valve Size		Diameter	Length	Quantity	Diameter	Length	Quantity
(in)	(mm)						
2	50	5/8"	4"	4	5/8"	1-1/2"	8
2.5	65	5/8"	4-1/4"	4	5/8"	1-1/2"	8
3	80	5/8"	4-1/2"	4	5/8"	1-3/4"	8
4	100	5/8"	5"	8	5/8"	1-3/4"	16
5	125	3/4"	5"	8	3/4"	1-3/4"	16
6	150	3/4"	5"	8	3/4"	2"	16
8	200	3/4"	6"	8	3/4"	2-1/4"	16
10	250	7/8"	6"	12	7/8"	2-1/4"	24
12	300	7/8"	6-1/2"	12	7/8"	2-1/2"	24
14	350	1"	7"	12	1"	2-3/4"	24
16	400	1"	8-1/2"	16	1"	3-1/4"	32
18	450	1-1/8"	9"	16	1-1/8"	3-1/2"	32
20	500	1-1/8"	10"	20	1-1/8"	4"	40
24	600	1-1/4"	11"	20	1-1/4"	4"	40

TABLE 2. STUD AND BOLT SPECIFICATION FOR LUG AND WAFER

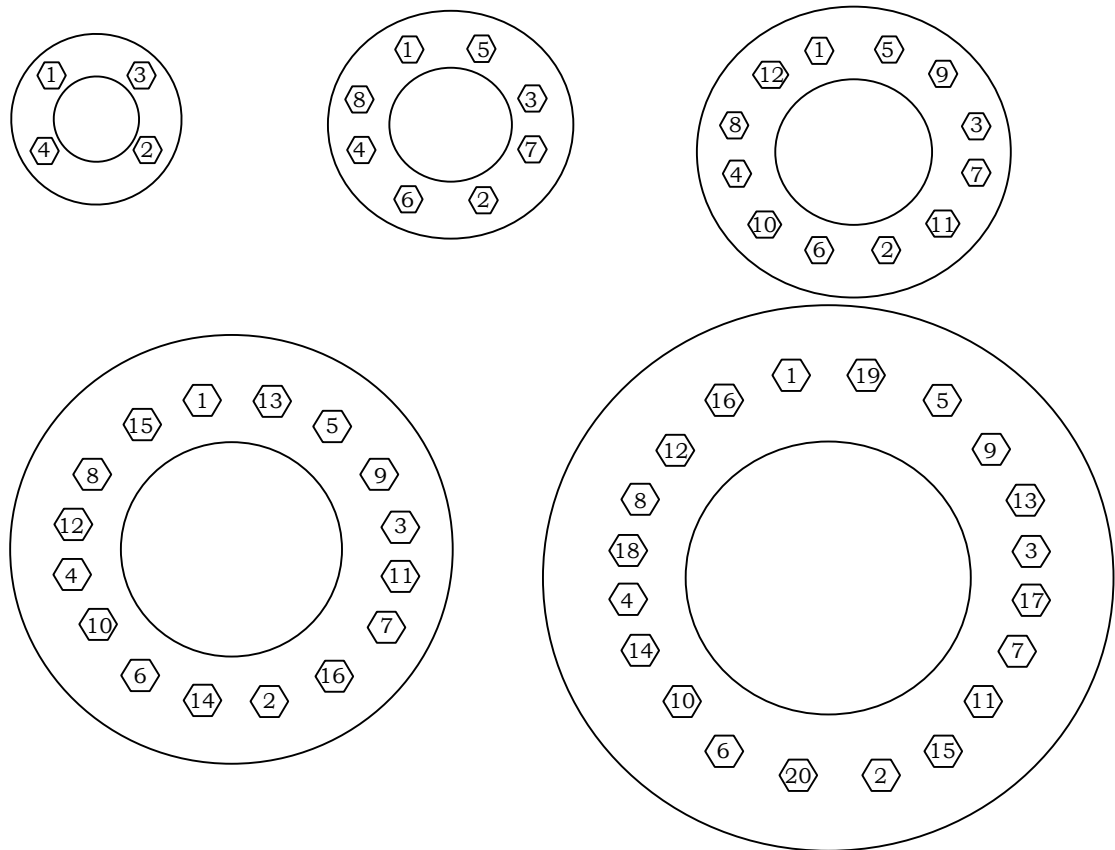

FIGURE 4. FLANGE BOLT TIGHTENING SEQUENCE

ASSEMBLY/DISASSEMBLY INSTRUCTIONS

141/143 SERIES BUTTERFLY VALVE ASSEMBLY AND DISASSEMBLY

The 141/143 Series butterfly valves **DO NOT** have field replaceable parts. Therefore, assembly or disassembly is not permitted. Once the valve is removed from the line, inspect the parts for wear. If valve parts show wear, replacement is necessary. Contact your local APOLLO® distributor for a replacement valve.

Type	Min	Max
Buna-N	+10 °F (-12 °C)	+180 °F (82 °C)
EPDM	-30 °F (-34 °C)	+275 °F (135 °C)

TABLE 3. 141/143 SERIES SEAT MATERIAL TEMPERATURE RANGES

BUTTERFLY VALVE PART LISTS

141/143 SERIES PARTS LIST

Item	Quantity	Description
1	1	Body
2	1	Seat
3	1	Shaft
4	1	Disc
5	1-2	Taper Pin
6	3	Bushing
7	1	Stem Seal

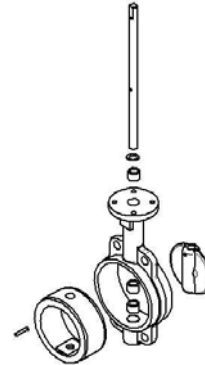

MANUAL OPERATOR INSTALLATION

LEVER HANDLE MOUNTING PROCEDURE

- Step 1. First, start by loosely assembling the notch plate on the valve top plate. The notchplate should be installed with the notches in the third quadrant of the valve top plate with the stop tabs at the 6 o'clock and 9 o'clock position. The notchplate should be installed with the stop tabs pointing upward (Figure 5).
- Step 2. Next, install the handle so that the lever fully engages in the notches when the lever is released and tighten the handle set screw.
- Step 3. Compress the handle lever and position the disc so that the valve is in the fully closed position. Align the last notch on the notchplate at the 9 o'clock position with the handle lever and tighten the notch plate screws.
- Step 4. Compress the handle lever and position the disc so that the valve is in the fully open position and release the lever. The lever should line-up with the last notch on the notchplate at the 6 o'clock position.

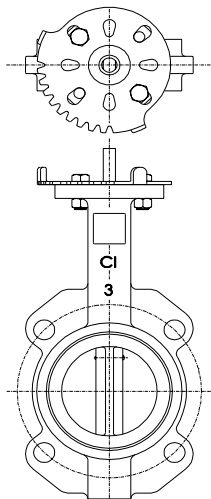

FIGURE 5. NOTCHPLATE INSTALLATION POSITION

MANUAL GEAR OPERATOR MOUNTING PROCEDURE

- Step 1. First, rotate the valve disc to the fully open position.
- Step 2. Next, slide the handwheel onto the end of the gear operator shaft. Line-up the hole in the handwheel with the hole in the gear operator shaft. Install the shear pin and rotate the gear operator to the open position.
- Step 3. Next, line-up the valve stem with the gear operator bore and slide the gear operator onto the valve with the handwheel pointing to the right of the valve when looking at the nameplate (Figure 6).
- Step 4. Position the gear operator so that the tapped holes in the bottom of the gear operator line-up with the valve top-plate mounting holes and install the mounting screws with lock washers.
- Step 5. Loosen the gear operator travel stops and rotate the handwheel until the valve is in the fully closed position. Tighten the gear operator stop on the right-hand side of the gear operator. (Note: There are two hex head set screws in tandem that represent the gear operator travel stops. Ensure that the first hex head screw is fully removed before loosening the travel stops.)
- Step 6. Rotate the handwheel until the valve is in the fully open position. Tighten the gear operator stop on the left-hand side of the gear operator.
- Step 7. Cycle the valve from the fully open position to the fully closed position to make sure that the stops are set correctly.

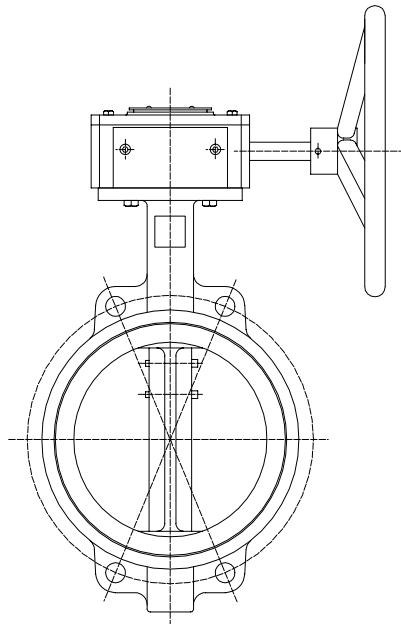

FIGURE 6. GEAR OPERATOR INSTALLATION POSITION

AMENDMENT REGISTER

<u>DATE</u>	<u>REV</u>	<u>SECTION</u>	<u>PAGE</u>	<u>DESCRIPTION</u>
12/10/01	C	All	All	Created as engineering standard.
01/28/03	D	All	All	Removed all 130/132 and 140/142 Series information. Added metric valve sizes, figure 6 and note to step 5 on page 9.