



# GREASE INTERCEPTORS

CANPLAS SECTION 22 13 23 GREASE INTERCEPTORS



Engineering grease management  
solutions for plumbing and  
food service professionals

[www.endurainterceptor.com](http://www.endurainterceptor.com)

**canplas**®

an OAliaxis company

# Canplas – Molding a Better Future

canplas®



Canplas is one of North America's leading producers of plastic products for the building and construction Industries and part of the Aliaxis Group of Companies. Specializing in injection moulded products, Canplas has five decades of expertise and experience in the manufacturing and distribution of plastic plumbing products, processing multiple materials and producing millions of fittings and products on an annual basis.

Endura grease interceptors have demonstrated effective, efficient and consistent performance with over a decade of field installation and operation. Endura is a multi-patented product built to withstand the toughest environments and provides the flexibility of in-floor, on-floor and semi-recessed application. Canplas has been instrumental in changing the traditional practices regarding the installation of grease management solutions, plastic alternatives to metal interceptors being now substantially accepted Nationwide as the new standard for grease management in commercial foodservice applications.

## Endura - Overview

### Grease Interceptor Series



#### Endura 7GPM - 10GPM - 15GPM Models

3907A02 - 7GPM (0.44 LPS) 2" (51mm) connection  
3910A02 - 10GPM (0.63 LPS) 2" (51mm) connection  
3915A02C - 15GPM (0.94 LPS) 2" (51mm) connection

Compact models use a development of the patented Canplas baffle system to enhance separation performance at low flow rates. EZ-Clean tank design – Aids exterior cleaning.



#### Endura Lo-PRO Grease Interceptor 25GPM Model

3925A02LO 25GPM (1.6 LPS) 2" (51mm) connection

Endura® Lo-PRO for tight on-floor applications where space is at a premium. Same dimensional footprint as 35gpm and 50gpm Endura® models. Overall height 11 inches, still meeting requirements of ASME112.14.3. Internal components can be removed in less than 6" of additional clearance.



#### Endura 20GPM - 25GPM Models

3920A02 20GPM (1.26 LPS) 2" (51mm) connection  
3925A02 25 GPM (1.6 LPS) 2" (51mm) connection  
3925A03 25 GPM (1.6 LPS) 3" (76mm) connection

Our original tank, 20-25gpm units are perhaps the most commonly installed product. Both 2" and 3" connections suit on-floor and in-floor application respectively.



#### Endura 35GPM Models

3935A03 35GPM (2.2 LPS) 3" (76mm) connection  
3935A04 35GPM (2.2 LPS) 4" (110 mm) connection

Structured foam molding technology provides rigidity and durability while reducing unit weight. Diffuser baffle aids separation at increased flow rates.



#### Endura 50GPM Models

3950A03 50 GPM (3.2 LPS) 3" (76 mm) connection  
3950A04 50 GPM (3.2 LPS) 4" (110 mm) connection

A tall version of our 35gpm model the 50gpm interceptor uses common parts incorporating all the best features of the Endura product design in a comparatively light weight solution to that of its metal competitors.

### Canplas Earth friendly solutions for Grease Management

Canplas is committed to the continuous improvement of our environmental performance and to meeting or exceeding the requirements of all applicable environmental laws and regulations.



**Recycling** our manufacturing process waste and office waste



**Economizing** in our use of water and energy to maximize **Energy Efficiency**



**Responsible Manufacturing** processes that helps protect the environment



**Continual Product Design** refinement to maximize efficiency while minimizing waste

### Durability

- Fewer installations and replacements result in lower lifetime costs & less landfill waste.
- Injection molded in engineered thermoplastics, Endura Grease Interceptors will not corrode, chip, or peel, even under the most severe Applications.
- Durability provides consistent operation – no compromise of effectiveness due to deterioration of key parts

### Green by Design



- Light-weight grease interceptor units enable smaller carbon footprint and low-emissions transport
- Injection molded

thermoplastic requires less energy to produce than metal grease interceptors

- Endura interceptors are manufactured a minimum of 5% recycled material.

## Grease Interceptors – Generic Types

The Grease interceptor industry has developed significantly in the past decade with not only more advanced and improved products but also development of performance standards and harmonization of common terms and references.

Traditionally the term “Grease Trap” was commonly applied and is still used in the industry today. This term is progressively disappearing from nomenclature and technical references based on an industry wide recognition that the term “trap” would suggest the presence of a water seal, integrally located within the interceptor. This practice substantially ceased many years ago, modern interceptors being designed to be installed in conjunction with external water seal traps as a standard part of the system.

In addition to this clarification, with publication of the 2006 UPC plumbing code three generic types of Grease Interceptor were introduced and have since become the industry standard for designating the type of interceptor being considered.

**Generically the application of a Grease Interceptor regardless of type is defines as follows:**

**Grease Interceptor:** “A plumbing appurtenance or appliance that is installed in a sanitary drainage system to intercept nonpetroleum fats, oil, and grease (FOG) from a wastewater discharge.

**Specific characteristics then define the three types of Interceptor:**

### Hydromechanical Grease Interceptor (HGI)

“An HGI is sized by flow rate (GPM) and qualified separation/retention efficiency, validated against National performance Standards. An HGI incorporates a defined means of flow control, acts to entrain air to influent, includes interior baffling, or barriers in combination or separately, working to promote hydromechanical separation. HGI’s are generally installed inside the facility they serve.”

### Gravity Grease Interceptor (GGI)









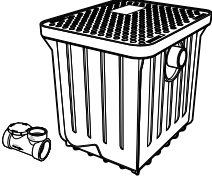

“A GGI is characterized by volume, minimum 30 minute retention time, baffle(s), not less than two compartments, a total volume of not less than 300 gallons (1135 L), and gravity separation. If not recognized by an official body, a GGI will be designed by a registered professional engineer. GGI’s are generally installed outside the building they serve and buried below grade.”

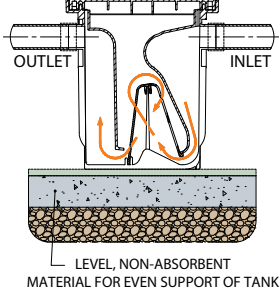
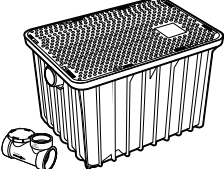

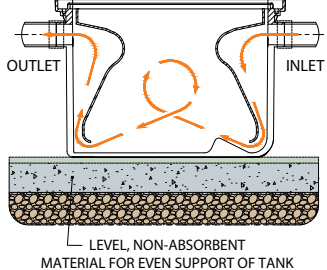
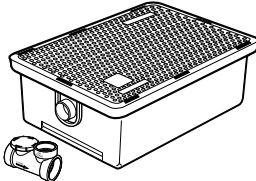

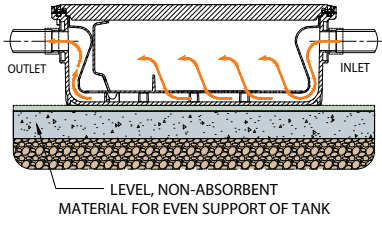
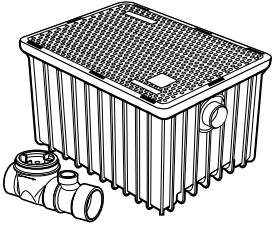

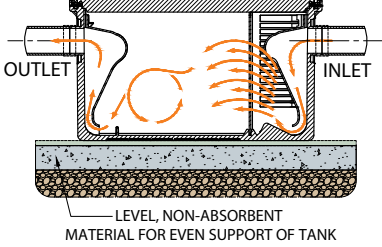
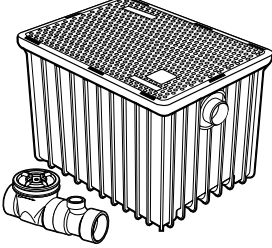

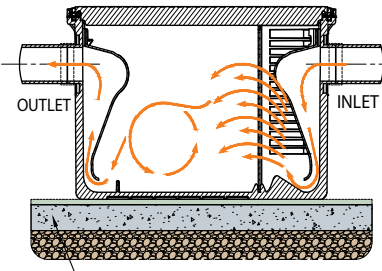

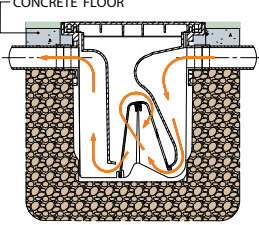

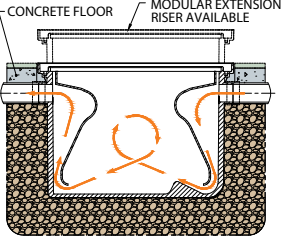
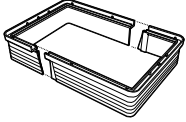

### Grease removal Device (GRD)

A GRD is a hydromechanical grease interceptor that mechanically removes non-petroleum fats, oils and grease (FOG) from the separation chamber, the control of which is either automatic or manually initiated and involves maintaining liquefied state of intercepted FOG by heating. GRD’s are installed inside the facility they serve.”

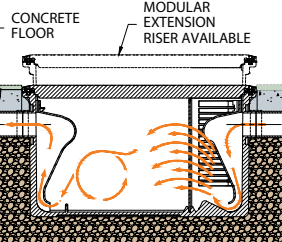
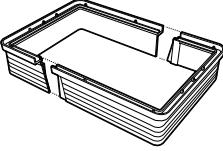
## Hydromechanical Grease Interceptor VS. Other Grease Interceptors

	Canplas Endura (HGI)	Hydromechanical Grease Interceptors (HGI)	Gravity Grease Interceptors (GGI)	Grease Removal Device (GRD)
<b>National Performance Standards</b>	- PDI G101 - CSA B481 - ASME A112.14.3	- PDI G101 - CSA B481 - ASME A112.14.3	None	- PDI G101 - CSA B481 - ASME A112.14.4
<b>Plumbing Code Approvals/ Listing</b>	- UPC - IPC - NPCC - NSPC	- UPC - IPC - NPCC - NSPC	- UPC (500 USG+) - IPC (300 USG+) - NPCC - NSPC	- UPC - IPC
<b>Specific AHJ Approval</b>	Typically Not	Typically Not	Yes	Yes
<b>Material</b>	Plastic (PP- Polypropylene)	- Cast Iron - Epoxy Coated Steel - Plastic (PE)	- GRP/Fiberglass - Concrete - Steel	Stainless Steel
<b>Efficiency</b>	93%-99% - Based on ASME A112.14.3 - Tested to breakdown	Min 90% (based on Performance Standards)	No Assessment Possible	Min 90% (based on Performance Standards)
<b>Average Lifespan</b>	Min 20 years - Typically life of system	- Cast Iron (10-15 yrs) - Epoxy Coated Steel (3-5yrs) - Plastic (PE) (20yrs +)	- GRP/Fiberglass (20Yrs+) - Concrete (8-10yrs) - Steel (7-12yrs)	- Tank (10Yrs+) - Mechanical (1-3yrs)
<b>Managed Flow</b>	Yes - with Accessible Flow control	Yes (Required for PDI compliance)	No	Yes
<b>Cost Ratio Index - Product</b>	1	.9 - 1.5	8-10	6-8
<b>Annual Operation Cost Ratio (Assumes third party service)</b>	1	1	8-10	0.5-1
<b>Footprint Ratio</b>	1	1	Min 10	1
<b>Sizing Method</b>	Flow Rate	Flow Rate	Capacity (US Gallons)	Flow Rate
<b>Typical Installation Time</b>	- On-Floor - 2-3hrs - In Floor - 4-6hrs	- On-Floor - 2-3hrs - In Floor - 4-8hrs	12-15hrs	2-4hrs
<b>Nature of Installation</b>	- Licensed Plumber - Common tools/practices	- Licensed Plumber - Common tools/practices	- Licensed Plumber/ Groundworker - Earthmoving/Excavation	- Licensed Installer - Common tools/practices
<b>Installer Profile</b>	- Licensed Plumber	- Licensed Plumber	- Licensed Plumber (Hook Up) - Ground worker (Install)	- Licensed Plumber - Licensed Electrician
<b>Product Availability</b>	- Stock Item - National/Regional/ Local Plumbing Wholesale - Restaurant Equipment Distributors	- National/Regional/ Local Plumbing Wholesale - Restaurant Equipment Distributor	- Local/Regional Manufacturer Direct - Special Order -Regional/Local Plumbing Wholesale	- Manufacturer Direct - Local Representation

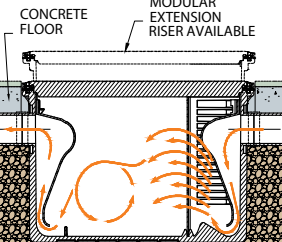
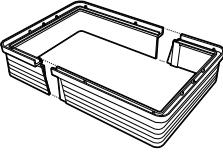
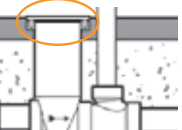
Product	Description	Connection Size	Recycled Content	On-Floor
 <p><b>Endura Compact Grease Interceptor</b> - 7 GPM 3907A02 - 10 GPM 3910A02 - 15 GPM 3915A02C</p>	<ul style="list-style-type: none"> <li>- Compact tank / small footprint</li> <li>- Injection molded in proven engineered thermoplastics for strength and durability</li> <li>- EZ-Open cover latches</li> <li>- Odor lock cover gasket</li> <li>- EZ-Clean exterior tank profile with a non-ribbed section at the lower two inches of the tank</li> <li>- 10 Year Limited Manufacturers Warranty</li> </ul>	<ul style="list-style-type: none"> <li>- 7 GPM 3907A02 - 2"</li> <li>- 10 GPM 3910A02 - 2"</li> <li>- 15 GPM 3915A02C - 2"</li> </ul>  <p>Connected using mechanical joint couplings allowing for use of various piping materials.</p>	<p>Minimum of 5%</p> 	 <p>LEVEL, NON-ABSORBENT MATERIAL FOR EVEN SUPPORT OF TANK</p>
 <p><b>Endura Grease Interceptor</b> - 20 GPM 3920A02 - 25 GPM 3925A02 - 25 GPM 3925A03</p>	<ul style="list-style-type: none"> <li>- Injection molded in proven engineered thermoplastics for strength and durability</li> <li>- EZ-Open cover latches</li> <li>- Odor lock cover gasket</li> <li>- Load rated cover supports up to 440 pounds of pedestrian and light duty traffic</li> <li>- 25gpm with 2" or 3" connections</li> <li>- 10 Year Limited Manufacturers Warranty</li> </ul>	<ul style="list-style-type: none"> <li>- 20 GPM 3920A02 - 2"</li> <li>- 25 GPM 3925A02 - 2"</li> <li>- 25 GPM 3925A03 - 3"</li> </ul>  <p>Connected using mechanical joint couplings allowing for use of various piping materials.</p>	<p>Minimum of 5%</p> 	 <p>LEVEL, NON-ABSORBENT MATERIAL FOR EVEN SUPPORT OF TANK</p>
 <p><b>Endura Low Profile Grease Interceptor</b> - 25 GPM 3925A02LO</p>	<ul style="list-style-type: none"> <li>- 11" in height, ideal for under sink installation</li> <li>- Requires only 6" of clearance for maintenance</li> <li>- Injection molded in proven engineered thermoplastics for strength and durability</li> <li>- EZ-Open cover latches</li> <li>- Odor lock cover gasket</li> <li>- EZ-Clean tank exterior</li> <li>- 10 Year Limited Manufacturers Warranty</li> </ul>	<ul style="list-style-type: none"> <li>- 25 GPM 3925A02LO - 2"</li> </ul>  <p>Connected using mechanical joint couplings allowing for use of various piping materials.</p>	<p>Minimum of 5%</p> 	 <p>LEVEL, NON-ABSORBENT MATERIAL FOR EVEN SUPPORT OF TANK</p>
 <p><b>Endura Grease Interceptor</b> - 35 GPM 3935A03 - 35 GPM 3935A04</p>	<ul style="list-style-type: none"> <li>- Injection molded in proven engineered thermoplastics for strength and durability</li> <li>- EZ-Open cover latches</li> <li>- Odor lock cover gasket</li> <li>- Load rated cover supports up to 440 pounds of pedestrian and light duty traffic</li> <li>- 10 Year Limited Manufacturers Warranty</li> <li>- Supplied with 2 piece flow control</li> </ul>	<ul style="list-style-type: none"> <li>- 35 GPM 3935A03 - 3"</li> <li>- 35 GPM 3935A04 - 4"</li> </ul>  <p>Connected using mechanical joint couplings allowing for use of various piping materials.</p>	<p>Minimum of 5%</p> 	 <p>LEVEL, NON-ABSORBENT MATERIAL FOR EVEN SUPPORT OF TANK</p>
 <p><b>Endura Grease Interceptor</b> - 50 GPM 3950A03 - 50 GPM 3950A04</p>	<ul style="list-style-type: none"> <li>- Injection molded in proven engineered thermoplastics for strength and durability</li> <li>- EZ-Open cover latches</li> <li>- Odor lock cover gasket</li> <li>- Load rated cover supports up to 440 pounds of pedestrian and light duty traffic</li> <li>- 10 Year Limited Manufacturers Warranty</li> <li>- Supplied with 2 piece flow control</li> </ul>	<ul style="list-style-type: none"> <li>- 50 GPM 3950A03 - 3"</li> <li>- 50 GPM 3950A04 - 4"</li> </ul>  <p>Connected using mechanical joint couplings allowing for use of various piping materials.</p>	<p>Minimum of 5%</p> 	 <p>LEVEL, NON-ABSORBENT MATERIAL FOR EVEN SUPPORT OF TANK</p>

In-Floor	Extension Riser	Flow Control Extension	Standards Conformance	Listings	Thermal Capability	Remarks
 <p>CONCRETE FLOOR</p> <ul style="list-style-type: none"> <li>• Check local codes for acceptance of in-floor installation</li> <li>• Finish to floor level accommodating requisite materials, E.G. Tile, mortar, etc.</li> </ul>	N/A	N/A	 <p>* Excluding 7 GPM</p>	<p>NYC Commonwealth of Massachusetts</p> 	Continuous discharge at 104° C (220° F)	<p>3-Part Master Format Specifications, CAD drawings &amp; BIM drawings available at <a href="http://ARCAT.com">ARCAT.com</a></p> <p>Installation Guide available at <a href="http://endurainterceptor.com">endurainterceptor.com</a></p>
 <p>CONCRETE FLOOR MODULAR EXTENSION RISER AVAILABLE</p> <ul style="list-style-type: none"> <li>• Finish to floor level accommodating requisite materials, E.G. Tile, mortar, etc.</li> </ul>	 <p><b>6" Modular riser</b> - Measurement markings - Stackable up to 3 sets (18" Total) - 3920AX6</p>	 <p><b>Sleeve kit for 3" model only, allows access to in-floor flow control device</b> Custom length of SDR 35 or SDR 28 sewer pipe to be used for access sleeve - <b>3" 392203W</b>, 6" SDR 35/28 sewer pipe diameter - <b>3" 392203W</b>, 6" SDR 35/28 sewer pipe diameter</p>		<p>NYC Commonwealth of Massachusetts</p> 	Continuous discharge at 104° C (220° F)	<p>3-Part Master Format Specifications, CAD drawings &amp; BIM drawings available at <a href="http://ARCAT.com">ARCAT.com</a></p> <p>Installation Guide available at <a href="http://endurainterceptor.com">endurainterceptor.com</a></p>
<p><b>On-Floor Installation Only</b></p>	N/A	N/A		<p>NYC Commonwealth of Massachusetts</p> 	Continuous discharge at 104° C (220° F)	<p>3-Part Master Format Specifications, CAD drawings &amp; BIM drawings available at <a href="http://ARCAT.com">ARCAT.com</a></p> <p>Installation Guide available at <a href="http://endurainterceptor.com">endurainterceptor.com</a></p>
 <p>CONCRETE FLOOR MODULAR EXTENSION RISER AVAILABLE</p> <ul style="list-style-type: none"> <li>• Finish to floor level accommodating requisite materials, E.G. Tile, mortar, etc.</li> </ul>	 <p><b>6" Modular riser</b> - Measurement markings - Stackable up to 3 sets (18" Total) - 3935AX6</p>	 <p><b>Sleeve kit allows access to in-floor flow control device</b> Custom length of SDR 35 or SDR 28 sewer pipe to be used for access sleeve - <b>3" 392203W</b>, 6" SDR 35/28 sewer pipe diameter - <b>4" 392204W</b>, 8" SDR 35/28 sewer pipe diameter</p>		<p>NYC Commonwealth of Massachusetts</p> 	Continuous discharge at 104° C (220° F)	<p>3-Part Master Format Specifications, CAD drawings &amp; BIM drawings available at <a href="http://ARCAT.com">ARCAT.com</a></p> <p>Installation Guide available at <a href="http://endurainterceptor.com">endurainterceptor.com</a></p>
 <p>CONCRETE FLOOR MODULAR EXTENSION RISER AVAILABLE</p> <ul style="list-style-type: none"> <li>• Finish to floor level accommodating requisite materials, E.G. Tile, mortar, etc.</li> </ul>	 <p><b>6" Modular riser</b> - Measurement markings - Stackable up to 3 sets (18" Total) - 3935AX6</p>	 <p><b>Sleeve kit allows access to in-floor flow control device</b> Custom length of SDR 35 or SDR 28 sewer pipe to be used for access sleeve - <b>3" 392203W</b>, 6" SDR 35/28 sewer pipe diameter - <b>4" 392204W</b>, 8" SDR 35/28 sewer pipe diameter</p>		<p>NYC Commonwealth of Massachusetts</p> 	Continuous discharge at 104° C (220° F)	<p>3-Part Master Format Specifications, CAD drawings &amp; BIM drawings available at <a href="http://ARCAT.com">ARCAT.com</a></p> <p>Installation Guide available at <a href="http://endurainterceptor.com">endurainterceptor.com</a></p>

# Dimensions

## Endura® 7GPM - 10GPM - 15GPM Models

3907A02 - 7GPM (0.44 LPS)  
2" (51mm) connection

3910A02 - 10GPM (0.63 LPS)  
2" (51mm) connection

3915A02C - 15GPM (0.94 LPS)  
2" (51mm) connection

**Notes:**

ACCESSIBLE FLOW CONTROL DEVICE (FCD) IS SUPPLIED FOR INSTALLATION UPSTREAM OF THE GREASE INTERCEPTOR (GI) -2" INLET/OUTLET MODELS

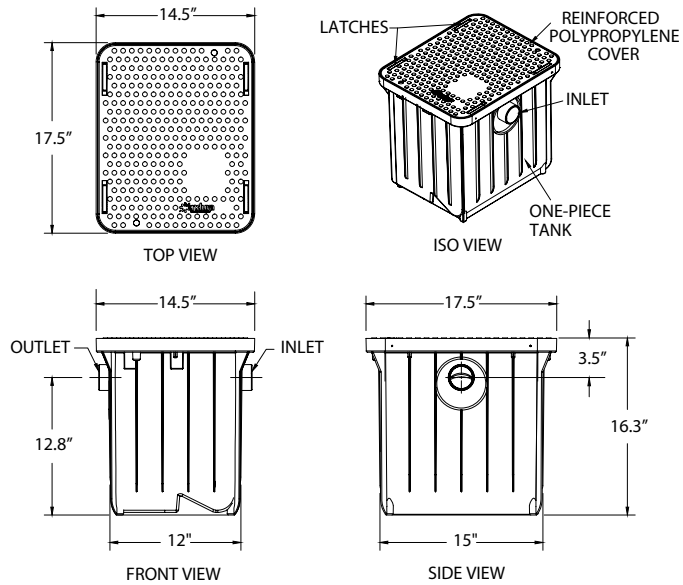

## Endura® 20GPM - 25GPM Models

3920A02 20GPM (1.26 LPS)  
2" (51mm) connection

3925A02 25 GPM (1.6 LPS)  
2" (51mm) connection

3925A03 25 GPM (1.6 LPS)  
3" (76mm) connection

**Notes:**

ACCESSIBLE FLOW CONTROL DEVICE (FCD) IS SUPPLIED FOR INSTALLATION UPSTREAM OF THE GREASE INTERCEPTOR (GI) -2" or 3" INLET/OUTLET MODELS

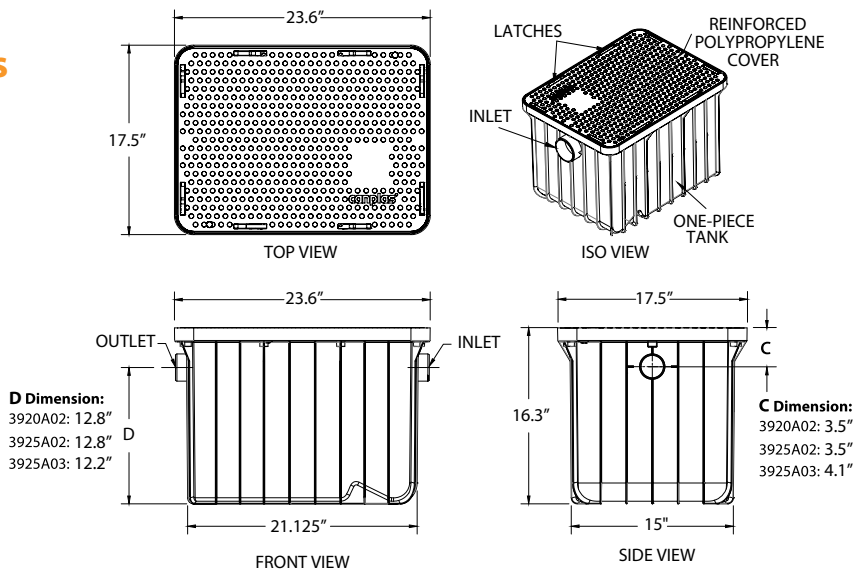

## Endura Lo-PRO Grease Interceptor 25GPM Model

3925A02LO 25GPM (1.6 LPS)  
2" (51mm) connection

**Notes:**

ACCESSIBLE FLOW CONTROL DEVICE (FCD) IS SUPPLIED FOR INSTALLATION UPSTREAM OF THE GREASE INTERCEPTOR (GI) -2" INLET/OUTLET MODEL

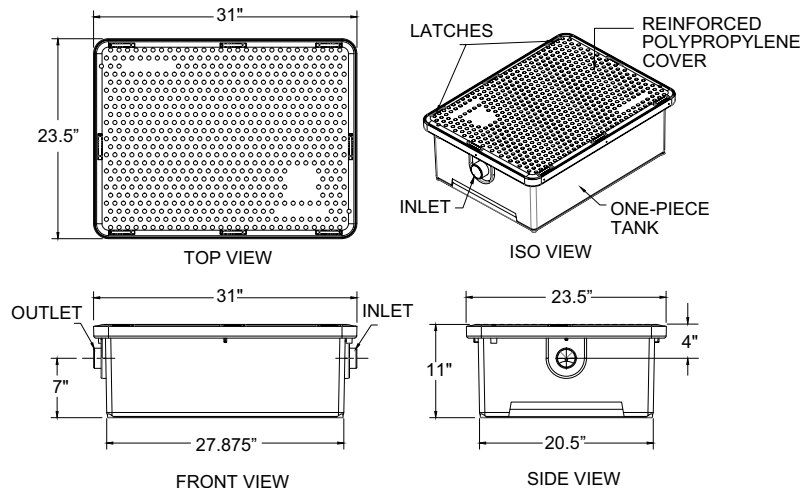

## Endura® 35GPM Models

3935A03 35GPM (2.2 LPS)  
3" (76mm) connection

3935A04 35GPM (2.2 LPS)  
4" (110 mm) connection

Notes:  
ACCESSIBLE FLOW CONTROL  
DEVICE (FCD) IS SUPPLIED  
FOR INSTALLATION UPSTREAM  
OF THE GREASE INTERCEPTOR (GI)  
-3" or 4" INLET/OUTLET MODELS

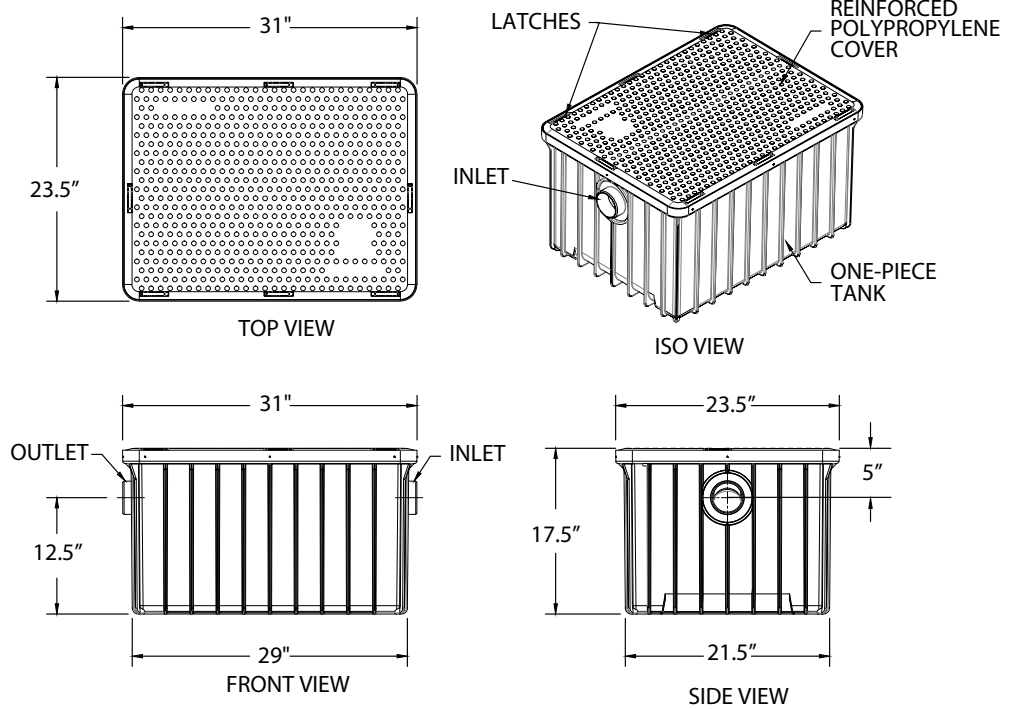

## Endura® 50GPM Models

3950A03 50 GPM (3.2 LPS)  
3" (76 mm) connection

3950A04 50 GPM (3.2 LPS)  
4" (110 mm) connection

Notes:  
ACCESSIBLE FLOW CONTROL  
DEVICE (FCD) IS SUPPLIED  
FOR INSTALLATION UPSTREAM  
OF THE GREASE INTERCEPTOR (GI)  
-3" or 4" INLET/OUTLET MODELS

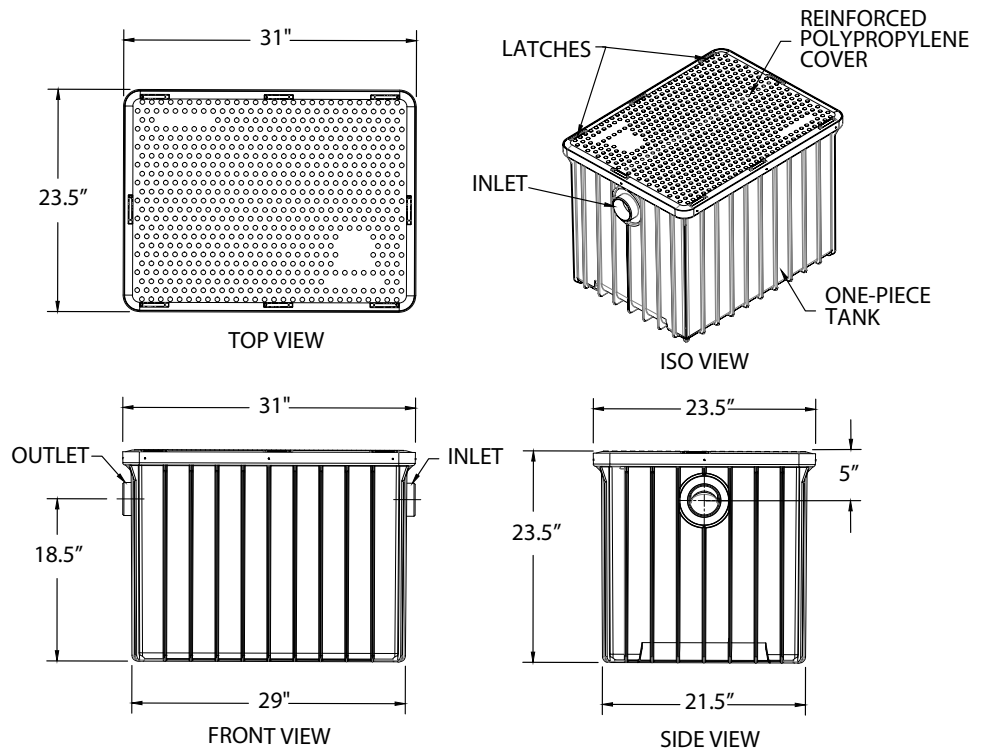

# Sizing

## Sizing by Flow Rate

For Endura models Canplas recommends sizing by flow rate. The use of a flow control with a Hydromechanical Grease Interceptor is considered mandatory. Without a properly sized flow control, the discharge rate through into the interceptor may exceed the design rating of the unit, causing lower efficiencies and increase the risk of grease, passing into the downstream system. Be careful not to confuse liquid capacity and flow rate. Liquid capacity is stated in gallons (or liters) while flow rate is referenced in gallons per minute (gpm) or L/sec.

If sizing based on a 1 minute drain time indicates that a higher flow rate interceptor is required, there are two options.

1. Use a larger interceptor to accommodate full accommodate the flow of the 1min drain down
2. Use a 2 min drain time in your calculation

**Note:** If using a 2 minute drain time this will cause the interceptor to be 50% of the original number calculated. Although a smaller unit will be less expensive, the lesser physical grease capacity will dictate an increased frequency of cleaning.

### Mop Sink Sizing Guide

Size	LPS	US/GPM
2"	84	22
3"	142	37.5
4"	170	45

### Floor Drains & Floor Sinks

Take the volume of water produced by the number of hose bibs (ie 1.5-2.0 gpm per 3/4" faucet)



Visit our website for our easy to use online GI Sizing Calculator.  
[www.EnduraGICalculator.com](http://www.EnduraGICalculator.com)

Table A - Procedure for Sizing Grease Interceptors

STEP	FORMULA	EXAMPLE
1	<b>Determine cubic content of fixture</b> by multiplying length x width x depth	A sink 24" long by 20" wide by 12" deep. Cubic content: 24 x 20 x 12 = 5,760 cubic inches (61.0 x 50.8 x 30.48 cm <sup>3</sup> )
2	<b>Determine capacity in gallons.</b> 1 gallon = 231 cubic inches	<b>Contents in gallons:</b> 5,760 / 231 = 24.9 gallons (94,451.42 / 1,000 = 94.45 litres)
3	<b>Determine actual drainage load.</b>  The fixture is normally filled to approximately 75% of capacity with water as the items being washed displace about 25% of the total fixture content.  Actual drainage load = 75% of fixture capacity	<b>Actual drainage load:</b> .75 x 24.9 = 18.7 gallons (0.75 x 94.45 = 70.84 litres)
4	<b>Determine flow rate and drainage period.</b> In general, good practice dictates a one minute drainage period; however, where conditions permit, a two minute drainage period is acceptable. Drainage period is defined as the actual time required to completely drain the fixture. Flow rate = $\frac{\text{Actual Drainage Load}}{\text{Drainage Period}}$	<b>Calculate flow rate for one minute drainage period:</b> 18.7 / 1 = 18.7 g.p.m. flow rate (70.84 / 1 min. = 70.84 l.p.m.) <b>Calculate flow rate for two minute drainage period:</b> 18.7 / 2 = 9.4 g.p.m. flow rate (70.84 / 2 min. = 35.42 l.p.m.)
5	<b>Select Interceptor.</b> From Table B select the interceptor with a flow rating at least equal to the calculated flow rate. When the calculated flow rate falls between two sizes, select the larger of the two interceptors.	<b>For a one minute drainage period:</b> 18.7 g.p.m. (70.84 l.p.m.) flow rate = 20 g.p.m. G.I. <b>For a two minute drainage period:</b> 9.4 g.p.m. (35.42 l.p.m.) flow rate = 10 g.p.m. G.I.

Table B - Procedure for Sizing Grease Interceptors

PDI Size Symbol	4	7	10	15	20	25	35	50
Flow Rate US Gallons per Minute (GPM)	4	7	10	15	20	25	35	50
Flow Rate Liters per Second (LPS)	.25	.44	.63	.95	1.26	1.58	2.20	3.16
Grease Capacity Pounds (Lbs)	8	14	20	30	40	50	70	100
Grease Capacity Kilograms (Kgs)	3.63	6.35	9.07	13.61	18.14	22.68	31.75	45.36

# Technical Specifications

PDI Rating (GPM)	7	10	15	20	25 LO	25	35	50
Capacity - min. (lbs)	14	20	30	40	50	50	70	100
Litres Per Second - (LPS)	0.44	0.63	0.94	1.26	1.6	1.6	2.2	3.2
Capacity - (Kg)	6.35	9.07	13.6	18.1	22.68	22.7	31.8	45.4
Endura Part Number	3907A02	3910A02	3915A02C	3920A02	3925A02LO	3925A02 (2") 3925A03 (3")	3935A03 (3") 3935A04 (4")	3950A03 (3") 3950A04 (4")
Average Efficiency % (ASME A112.14.3)	95.5%	92.5%	92.0%	95.4%	97.1%	92.5%	98.6%	93.9%
Actual Grease Capacity lbs (Kg)	31.95 (14.49)	33.1 (17.28)	34.97 (18.58)	76.4 (34.65)	53.4 (24.22)	* 74 (33.6)	138.5 (62.8)	* 122 (55.3)
Operating Temperature Capabilities	220°F (104°C)	220°F (104°C)	220°F (104°C)	220°F (104°C)	220°F (104°C)	220°F (104°C)	220°F (104°C)	220°F (104°C)
Cover Load Capacity	440 lbs (200 kgs)	440 lbs (200 kgs)	440 lbs (200 kgs)	440 lbs (200 kgs)	440 lbs (200 kgs)	440 lbs (200 kgs)	440 lbs (200 kgs)	440 lbs (200 kgs)
Unit Weight Capacity (Empty)	15.8Lbs (7.17kgs)	15.8Lbs (7.17kgs)	15.8Lbs (7.17kgs)	23 lbs (10.4 kgs)	23.9 lbs (10.85 kgs)	23 lbs (10.4 kgs)	45 lbs (20.4 kgs)	60 lbs (27.2 kgs)
Liquid Capacity	12.96 gal (49.06 L)	12.96 gal (49.06 L)	12.96 gal (49.06 L)	21.6 gal (81.8 L)	18.9 gal (71.54L)	21.6 gal (81.8 L)	39.4 gal (149.1 L)	52.0 gal (197 L)
Connection size (nominal)	2"	2"	2"	2"	2"	2" (3925A02) 3" (3925A03)	3" (3935A03) 4" (3935A04)	3" (3950A03) 4" (3950A04)

Capacity based PDI G101 minimum requirements for respective GPM rating at ASME A112.14.3 Breakdown. Actual Grease Capacity recorded at Breakdown of ASME A112.14.3 test.

## Dimensions - Flow Control Device Assembly



1 Piece Compact Flow Control

Flow Control & Air Intake Combined	
Connection Iron Pipe Size (Solvent weld)	Compact 2" h x h
A	3.94" (100mm)
B	3.44" (87.4mm)
C	-



2 Piece Flow Controls (3" Version Illustrated)

Connection Iron Pipe Size (Solvent weld)	Flow Control Body			Air Intake Tee	
	2" h x h	3" h x h	4" h x h	3" spg x h	4" spg x h
A	3" (76.2mm)	4.23" (107.4mm)	6.13" (155.7mm)	2.67" (67.8mm)	3.19" (81mm)
B	3.84" (97.5mm)	5.93" (151mm)	6.84" (173.7mm)	4.01" (101.9mm)	5.04" (128mm)
C	-	-	-	2.27" (57.7mm)	2.72" (69.1mm)

## Installation

Every Canplas interceptor is supplied with full installation and operation instructions.

The Installation, Use & Care manual is available for reference at

[http://www.canplasplumbing.com/Portals/9/ProductDownloads/3935A-17\\_Endura\\_GI\\_Manual.pdf](http://www.canplasplumbing.com/Portals/9/ProductDownloads/3935A-17_Endura_GI_Manual.pdf)

### Cautions - Before designing your drainage system



**WARNING!**  
**DO NOT PRESSURE TEST.**  
**RISK OF SERIOUS INJURY.**

As a gravity fed plumbing appurtenance, a grease interceptor **MUST** be isolated from the drainage system in the event that final drain testing or other system pressure testing is required by the AHJ.



**Venting** - Grease Interceptors must have a vented waste, sized in accordance with local code requirements for venting interceptors to retain a water seal and prevent siphoning. Most codes dictate that two vents be installed, one upstream and one downstream of the grease interceptor. The upstream vent must not be placed between the air intake and the grease interceptor.



**CAUTION**

**System longer than 8 feet?** - If more than 8 feet (2.4 m) of fall exists between appliance outlet and interceptor inlet, a secondary flow control must be installed immediately preceding the grease interceptor to maintain flow velocities in the system. See installation drawing.



**CAUTION**

**Installed under a sink** - If installed under a sink or similar obstruction ensure there is sufficient clearance to remove the baffles for cleaning and maintenance. Clearance of 21" for 50 GPM models, 5" for LoProfile model, 15" for all other models. If this is not practical, semi-recessing the tank may be an option.



**CAUTION**

**Floor Drains** - Some local jurisdictions require that the interceptor service the floor drains. The floor drain must bypass the flow control to ensure the restriction does not flood the drain. Therefore, the flow control should be installed as close to the fixture as possible or directly preceding the floor drain connection.

# Installation

## Tank Connections

All Endura Grease Interceptors are manufactured with standard no hub connections to accept locally approved/accepted MJ (Mechanical Joint) couplings.

This method allows resilience in the connections to prevent stress and a flexible means of integrating metallic or plastic plumbing systems. Should adaption of pipe connection be required, use appropriate mechanical joint reducers but do not allow decrease pipe diameter across the unit. (i.e. 3 inch inlet, 2 inch outlet.)

Due to regional and local code variation, models with threaded connections (FPT) are available by adding suffix 'T' to the part number. Both tank and flow control (TFCD) will be supplied with FPT connections in this instance based on the respective nominal pipe size. Likewise Endura Interceptors can be supplied with spigot format flow controls (SFCD) by adding suffix 'S' to the part number.

**Please Note: Solvent cement is not an acceptable jointing method from the piping system to the interceptor. This will result in leakage.**

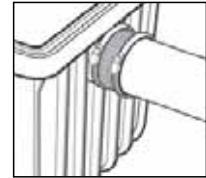
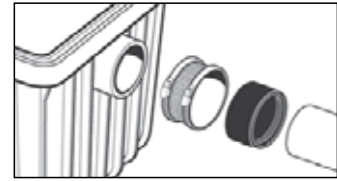

## Flow Control Installation

The flow control device furnished with the Endura Grease Interceptor is essential to the proper operation of this unit. The flow control limits the unit to its rated capacity allowing enough time for grease separation to take place inside the interceptor. The flow control fitting is molded in PVC and must be solvent welded using PVC or PVC/ABS transition cement as appropriate. It is to be located in the drain line beyond the last connection from the fixture and as close as possible to the underside of the lowest fixture, see page 6-7 for typical installation. When the discharge from two or more sinks or fixtures are combined and served by one interceptor, a single flow control fitting should be used.

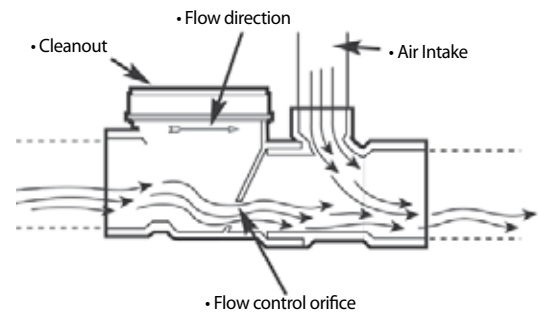

The flow control device can be recessed into the floor if required and extension sleeves are available to complete a good finish at final floor level.



**Compact Version**  
Example: 3922125C  
1 piece format



**Hub Version**  
Example: 3933125  
2 piece format  
- 3" & 4" models  
(2" available)



**Spigot Version**  
Example: 3933125S  
2 piece format  
- 3" & 4" models  
(2" available)

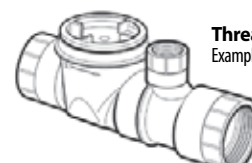

**Threaded Version**  
Example: 3933125T  
2 piece format  
- 3" & 4" models  
(2" available)

The installation of a ball valve upstream of the flow control is recommended. A ball valve provides a means of drain line isolation for maintenance.

Some local plumbing codes require that grease interceptors have an internal flow control to ensure drain lines do not bypass the grease interceptor. However, if the flow control device is located immediately upstream of an interceptor, this is often considered as forming part of the interceptor. Therefore, officials having jurisdiction may accept such design as meeting the intent of the requirement. If local codes dictate the flow control must be installed directly preceding the grease interceptor inlet, and the fixtures being served are in excess of 8 ft (2.4 m) from the interceptor, we recommend a second flow control being installed as close to the last fixture as possible. Please contact your local representative if you require further clarification.

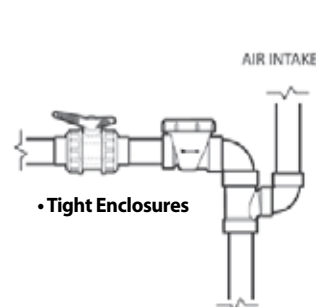
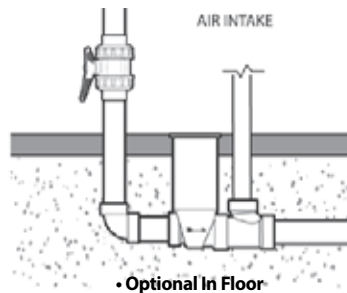
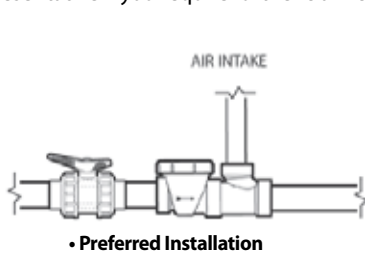

## Indirect Connections/ Air Gap

Some local jurisdictions require warewashing installations to be made on an indirect basis incorporating an air gap.

An air gap prevents back up of contaminated water into the sinks/appliances in the event of a system back flow. The flow control device must be incorporated before the indirect connection to prevent overflow occurring during high/maximum waste water discharge. If an air gap is located within 6" of flow control device\*, installation of the air intake tee is optimal. (\*Verify with Authority Having Jurisdiction)

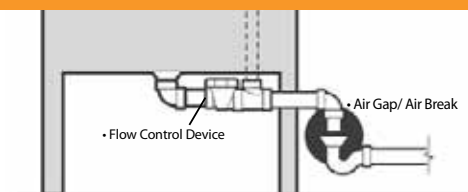

# Installation

## • Typical On Floor

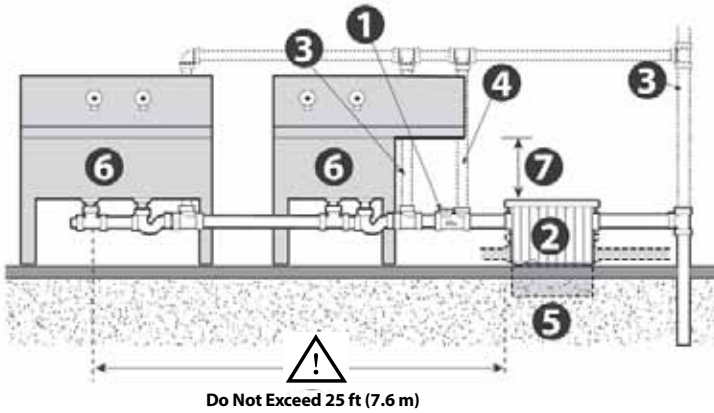

**CAUTION: CLEARANCE REQUIRED**  
15" clearance (21" for 50 GPM model) to remove the baffles for cleaning and maintenance.

- 1 • Flow Control Device
- 2 • Grease Interceptor
- 3 • Vented Waste
- 4 • Air Intake
- 5 • Semi Recessed Option
- 6 • Sink
- 7 • ⚠ Minimum Clearance 15" / 21"

## • Typical In Floor

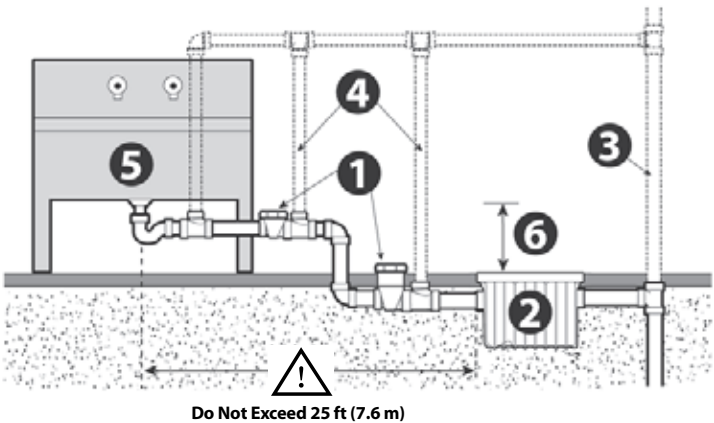

**When backfilling in-floor, the interceptor must have both the cover fitted and be filled with water to the inlet/outlet level.** This will ensure the tank itself will not move during backfilling, pouring and/or floor finishing. When backfilling in particular, care should be taken to do so evenly around the unit and with light manual pressure only.



Ensure that the interceptor is clearly identified to flooring contractors to prevent it from being covered with flooring material. Taping cardboard to the cover is generally effective.



**CAUTION: CLEARANCE REQUIRED**  
15" clearance (21" for 50 GPM model) above the grease interceptor is required to remove the baffles for cleaning and maintenance.

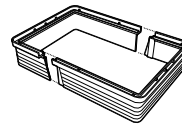

**6" Modular risers available where deeper installation is necessary to accommodate existing drainage.**  
- Stackable up to 3 sets (18" Total)  
- 3920AX6 (20/25gpm) and 3935AX6 (35/50gpm)

- 1 • Flow Control Device
- 2 • Grease Interceptor
- 3 • Vented Waste
- 4 • Air Intake
- 5 • Sink
- 6 • ⚠ Minimum Clearance 15" / 21"

## • Lo-PRO Grease Interceptor

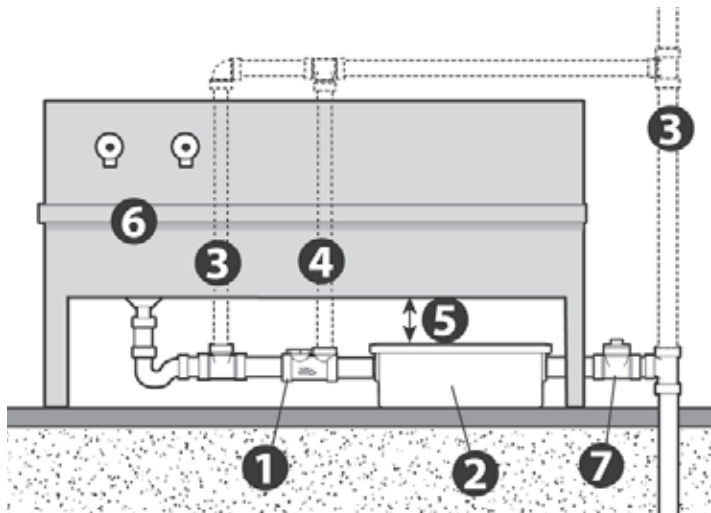

**CAUTION: CLEARANCE REQUIRED**  
6" clearance above the grease interceptor required to remove the baffles for cleaning and maintenance.

- 1 • Flow Control Device
- 2 • Grease Interceptor
- 3 • Vented Waste
- 4 • Air Intake
- 5 • ⚠ Minimum Clearance 6"
- 6 • Sink
- 7 • Cleanout may be required in some jurisdictions

## • Typical Multi-Story - Single Unit

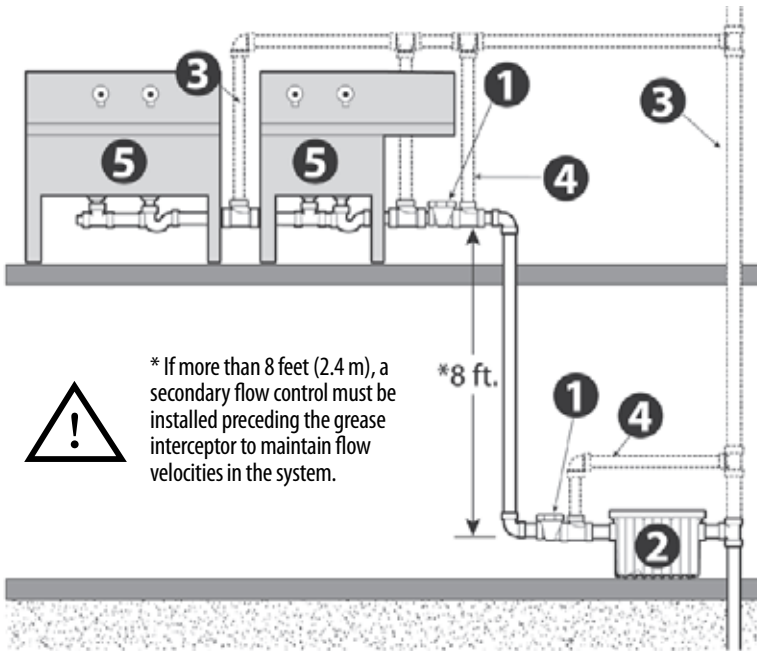

### Multiple Fixture Installation

One interceptor serving multiple fixtures is recommended only when the fixtures are located close together (max 25ft of developed pipe run). In such installations, each fixture should be individually trapped and back-vented.

- 1 • Flow Control Device
- 2 • Grease Interceptor
- 3 • Vented Waste
- 4 • Air Intake
- 5 • Sink

## • In Floor - Other

### • Fork Lift, Pump Truck Traffic Area

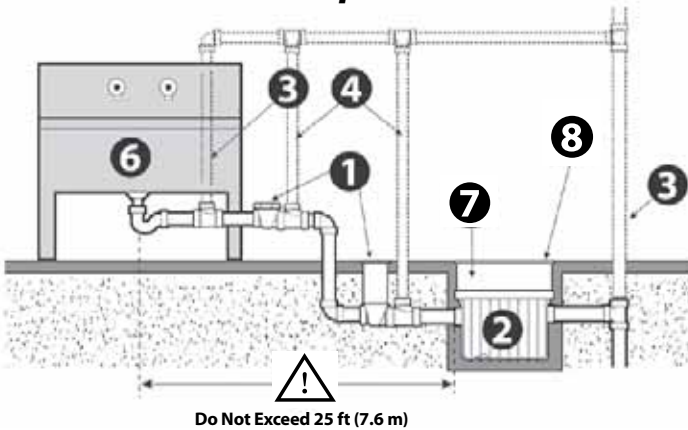

Provision of a concrete pit with a load rated access cover will be required where pump trucks or fork lifts travel.

- 1 • Flow Control Device
- 2 • Grease Interceptor
- 3 • Vented Waste
- 4 • Air Intake
- 5 • Hanger (Supplier by installer)
- 6 • Sink
- 7 • Concrete pit
- 8 • Load Rated Access Cover

## • Suspended Installation

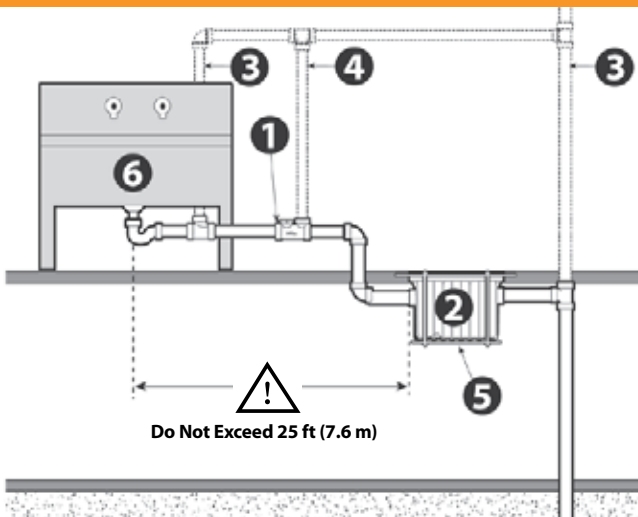

Due to the degree of risk and potential liability for the installer, great care must be taken in designing a hanger system. Canplas recommends consulting an engineer before installing in this manner.

- 1 • Flow Control Device
- 2 • Grease Interceptor
- 3 • Vented Waste
- 4 • Air Intake
- 5 • Hanger (Supplier by installer)
- 6 • Sink



Hanger must accommodate min. 541 lbs (246kg) plus safety.

# Specifications

**SPEC NOTE:** See [www.arcat.com](http://www.arcat.com) website for Microsoft Word (editable) document.

**SPEC NOTE:** Canplas LLC and Canplas Industries Ltd. are members of the Aliaxis Group of companies, a global leader of plastic solutions for fluid transport in the field of building materials. The Aliaxis Group provides products for both residential and commercial building markets, in new build and renovation segments, as well as a wide range of solutions for industrial and public utility applications.

## SECTION 22 13 23 - GREASE INTERCEPTORS

### PART 1 GENERAL

#### 1.1 SECTION INCLUDES

- A. Grease interceptors.

#### 1.2 RELATED SECTIONS

- A. Section 23 05 00 - Common Work Results for HVAC.

#### 1.3 REFERENCES

- A. CAN/CSA-B481.1: Testing and Rating of Grease Interceptors using Lard.

#### 1.4 SUBMITTALS

- A. Submit under provisions of Section 01 30 00 - Administrative Requirements.
- B. Product Data: Manufacturer's data sheets on each product to be used, including:
  - 1. Preparation instructions and recommendations.
  - 2. Storage and handling requirements and recommendations.
  - 3. Installation methods.

#### 1.5 QUALITY ASSURANCE

- A. Manufacturer Qualifications: Minimum 5 years experience manufacturing similar products.
- B. Installer Qualifications: Minimum 2 years experience installing similar products.

#### 1.6 PRE-INSTALLATION MEETINGS

- A. Convene minimum two weeks prior to starting Work of this section.

#### 1.7 DELIVERY, STORAGE, AND HANDLING

- A. Deliver and store products in manufacturer's unopened packaging bearing the brand name and manufacturer's identification until ready for installation.
- B. Handling: Handle materials to avoid damage.

#### 1.8 PROJECT CONDITIONS

- A. Maintain environmental conditions (temperature, humidity, and ventilation) within limits recommended by manufacturer for optimum results. Do not install products under environmental conditions outside manufacturer's recommended limits.

#### 1.9 SEQUENCING

- A. Ensure that products of this section are supplied to affected trades in time to prevent interruption of construction progress.

#### 1.10 WARRANTY

- A. Endura Grease and Solids Management as manufactured by Canplas Industries LLC shall be supported by a 10 year manufacturer's extended warranty.

## PART 2 PRODUCTS

### 2.1 MANUFACTURERS

- A. **Acceptable Manufacturer:** Canplas Industries Ltd.; 500 Veterans Dr. P.O. Box 1800, Barrie, ON, Canada L4M 4V3. ASD. Toll Free Tel: (800) 461-1771. Tel: (705) 726-3361. Fax: (705) 726-2186. Email: [canplas@canplas.com](mailto:canplas@canplas.com) Web: <http://www.canplas.com>
- B. **Substitutions:** Not permitted.
- C. Requests for substitutions will be considered in accordance with provisions of Section 01600.

### 2.2 GREASE MANAGEMENT

- A. Grease and solids management shall be from a single source of Endura Grease Management products manufactured by Canplas Industries Ltd.

### 2.3 GREASE INTERCEPTORS

- A. **Product: Endura Lo-Pro as manufactured by Canplas Industries Ltd.**
  - 1. **Model No. 3925A02LO.** The interceptor shall be serviced with a minimum of 6 inches (152 mm) of overhead clearance. The unit shall be comprised of engineered thermoplastics to withstand operational temperatures up to 220 degree F (104 degree C) comprising a pedestrian rated cover capable of supporting 440 lb (200 kg) and incorporating an operationally air tight seal. The cover shall also utilize a quick access latching system to functionally retain and secure the cover to the tank, but allow consistent removal and replacement of the cover without operational compromise. Functional elements such as baffles will be made of material that prevents corrosion or deterioration and shall be easily removable for the purposes of maintenance, providing unrestricted upstream and downstream drain access. The grease interceptor shall be certified to the current version of the PDI-G101, ASME A112.14.3 or CSA B481.1 and where locally applicable have UPC listing.
    - a. Flow: 25 US Gallons per Minute (1.6 liter per second).
    - b. Capacity: 50 Pounds (22.68 kg).
    - c. Average Efficiency % (ASME 112.4.3): 97.1%.
    - d. Grease Capacity lbs (Kg) actual: 53.4 (24.22).
    - e. Unit Weight (Empty): 23.9 lb (10.85 kg).
    - f. Liquid Capacity: 18.9 gal (71.54 L).
    - g. Connection size (mechanical): 2 inches (51 mm) (110 mm available on request).

2. **Model 3922125:** A flow control with a rate of 25 gpm (95 lpm) will also be installed in accordance to manufacturer's instructions.
    - a. Flow Control: 2 inches (51 mm) h x h.
    - b. Air Intake: 2 inches (51 mm) spg x h.
  - B. **Product: Endura Compact GI as manufactured by Canplas Industries Ltd.**
    1. The unit shall be comprised of engineered thermoplastics to withstand operational temperatures up to 220 degree F (104 degree C) comprising a pedestrian rated cover capable of supporting 440 lb (200 kg) and incorporating an operationally air tight seal. The cover shall also utilize a quick access latching system to functionally retain and secure the cover to the tank, but allow consistent removal and replacement of the cover without operational compromise. Functional elements such as baffles will be made of material that prevents corrosion or deterioration and shall be easily removable for the purposes of maintenance, providing unrestricted upstream and downstream drain access. The grease interceptor shall be certified to the current version of the PDI-G101, ASME A112.14.3 or CSA B481.1 and where locally applicable have UPC listing.
      - a. A flow control device with integrated air intake and tool-less access to the orifice in service shall be provided with the interceptor.
    2. **Model 3907A02 - ENDURA GI 7GPM/14LB.**
      - a. Flow Control: Model 3922107C.
      - b. Flow: 7 US Gallons per Minute (0.44 liter per second).
      - c. Capacity: 14 Pounds (6.35 kg).
      - d. Average Efficiency % (ASME 112.4.3): 95.5%.
      - e. Grease Capacity lbs (Kg) actual: 31.95 (14.49).
      - f. Unit Weight (Empty): 13.8 lb (6.26 kg).
      - g. Liquid Capacity: 12.96 gal (49.06 L).
      - h. Connection size (mechanical): 2 inches (51 mm)
    3. **Model 3910A02 - ENDURA GI 10GPM/20LB.**
      - a. Flow Control: Model 3922110C.
      - b. Flow: 10 US Gallons per Minute (0.63 liter per second).
      - c. Capacity: 20 Pounds (9.07 kg).
      - d. Average Efficiency % (ASME 112.4.3): 92.5%.
      - e. Grease Capacity lbs (Kg) actual: 38.1 (17.28).
      - f. Unit Weight (Empty): 13.8 lb (6.26 kg).
      - g. Liquid Capacity: 12.96 gal (49.06 L).
      - h. Connection size (mechanical): 2 inches (51 mm).
    4. **Model 3915A02C - ENDURA GI 15GPM/30LB.**
      - a. Flow Control: Model 3922115C.
      - b. Flow: 15 US Gallons per Minute (0.94 liter per second).
      - c. Capacity: 30 Pounds (13.6 kg).
      - d. Average Efficiency % (ASME 112.4.3): 92%.
      - e. Grease Capacity lbs (Kg) actual: 40.97 (18.58).
      - f. Unit Weight (Empty): 13.8 lb (6.26 kg).
      - g. Liquid Capacity: 12.96 gal (49.06 L).
      - h. Connection size (mechanical): 2 inches (51 mm).
  - C. **Product: Grease Interceptor 20-25 GPM as manufactured by Canplas Industries Ltd.**
    1. The unit shall be comprised of engineered thermoplastics to withstand operational temperatures up to 220 degree F (104 degree C) comprising a pedestrian rated cover capable of supporting 440 lb (200 kg) and incorporating an operationally air tight seal. The cover shall also utilize a quick access latching system to functionally secure and retain the cover to the tank, but allow consistent removal and replacement of the cover without operational compromise. Functional elements such as baffles will be made of material that prevents corrosion or deterioration and shall be easily removable for the purposes of maintenance, providing unrestricted upstream and downstream drain access. The grease interceptor shall be certified to the current version of the PDI-G101, ASME A112.14.3 or CSA B481.1 and where locally applicable have UPC listing.
      - a. A flow control device with integrated air intake and tool-less access to the orifice in service shall be provided with the interceptor.
- and replacement of the cover without operational compromise. Functional elements such as baffles will be made of material that prevents corrosion or deterioration and shall be easily removable for the purposes of maintenance, providing unrestricted upstream and downstream drain access. The grease interceptor shall be certified to the current version of the PDI-G101, ASME A112.14.3 or CSA B481.1 and where locally applicable have UPC listing.
- a. A flow control device with integrated air intake and tool-less access to the orifice in service shall be provided with the interceptor.
2. **Model 3920A02 - Endura GI 20GPM/40LB.**
    - a. Flow Control: 3911120C.
    - b. Flow: 20 US Gallons per Minute (1.26 liter per second).
    - c. Capacity: 40 Pounds (18.1 kg).
    - d. Average Efficiency % (ASME 112.4.3): 95.4%.
    - e. Grease Capacity lbs (Kg) actual: 76.4 (34.65).
    - f. Unit Weight (Empty): 23 lb (10.4 kg).
    - g. Liquid Capacity: 21.6 gal (81.8 L).
    - h. Connection size (mechanical): 2 inches (51 mm).
  3. **Model 3925A02 - Endura GI 25GPM/50LB.**
    - a. Flow Control: 3922125C.
    - b. Flow: 25 US Gallons per Minute (1.6 liter per second).
    - c. Capacity: 50 Pounds (22.7 kg).
    - d. Average Efficiency % (ASME 112.4.3): 92.5%.
    - e. Grease Capacity lbs (Kg) actual: 74 (33.6).
    - f. Unit Weight (Empty): 23 lb (10.4 kg).
    - g. Liquid Capacity: 21.6 gal (81.8 L).
    - h. Connection size (mechanical): 2 inches (51 mm).
  4. **Model 3925A03 - Endura GI 25GPM/50LB.**
    - a. Flow Control: 3933125.
    - b. Flow: 25 US Gallons per Minute (1.6 liter per second).
    - c. Capacity: 50 Pounds (22.7 kg).
    - d. Average Efficiency % (ASME 112.4.3): 92.5%.
    - e. Grease Capacity lbs (Kg) actual: 74 (33.6).
    - f. Unit Weight (Empty): 23 lb (10.4 kg).
    - g. Liquid Capacity: 21.6 gal (81.8 L).
    - h. Connection size (mechanical): 3 inches (76 mm).
- D. **Product: Grease Interceptor 35-50GPM as manufactured by Canplas Industries Ltd.**
    1. The unit shall be comprised of engineered thermoplastics to withstand operational temperatures up to 220 degree F (104 degree C) comprising a pedestrian rated cover capable of supporting 440 lb (200 kg) and incorporating an operationally air tight seal. The cover shall also utilize a quick access latching system to functionally secure and retain the cover to the tank, but allow consistent removal and replacement of the cover without operational compromise. Functional elements such as baffles will be made of material that prevents corrosion or deterioration and shall be easily removable for the purposes of maintenance, providing unrestricted upstream and downstream drain access. The grease interceptor shall be certified to the current version of the PDI-G101, ASME A112.14.3 or CSA B481.1 and where locally applicable have UPC listing.
      - a. A flow control device with integrated air intake and tool-less access to the orifice in service shall be provided with the interceptor.

2. **Model 3935A03 - Endura GI 35GPM/70LB.**
  - a. Flow Control: 3933135.
  - b. Flow: 35 US Gallons per Minute (2.2 liter per second).
  - c. Capacity: 70 Pounds (31.8 kg).
  - d. Average Efficiency % (ASME 112.4.3): 98.6%.
  - e. Grease Capacity lbs (Kg) actual: 138.5 (62.8).
  - f. Unit Weight (Empty): 45 lb (20.4 kg).
  - g. Liquid Capacity: 39.4 gal (149.1 L).
  - h. Connection size (mechanical): 3 inches (76 mm) (110 mm available on request).
3. **Model 3935A04 - Endura GI 35GPM/70LB.**
  - a. Flow Control: 3934135.
  - b. Flow: 35 US Gallons per Minute (2.2 liter per second).
  - c. Capacity: 70 Pounds (31.8 kg).
  - d. Average Efficiency % (ASME 112.4.3): 98.6%.
  - e. Grease Capacity lbs (Kg) actual: 138.5 (62.8).
  - f. Unit Weight (Empty): 45 lb (20.4 kg).
  - g. Liquid Capacity: 39.4 gal (149.1 L).
  - h. Connection size (mechanical): 4 inches (102 mm).
4. **Model 3950A03 - Endura GI 50GPM/100LB.**
  - a. Flow Control: 3933150.
  - b. Flow: 50 US Gallons per Minute (3.2 liter per second).
  - c. Capacity: 100 Pounds (45.4 kg).
  - d. Average Efficiency % (ASME 112.4.3): 93.9%.
  - e. Grease Capacity lbs (Kg) actual: 122 (55.3).
  - f. Unit Weight (Empty): 60 lb (27.2 kg).
  - g. Liquid Capacity: 52 gal (197 L).
  - h. Connection size (mechanical): 3 inches (76 mm) (110 mm available on request).
5. **Model 3950A04 - Endura GI 50GPM/100LB.**
  - a. Flow Control: 3934150.
  - b. Flow: 50 US Gallons per Minute (3.2 liter per second).
  - c. Capacity: 100 Pounds (45.4 kg).
  - d. Average Efficiency % (ASME 112.4.3): 93.9%.
  - e. Grease Capacity lbs (Kg) actual: 122 (55.3).
  - f. Unit Weight (Empty): 60 lb (27.2 kg).
  - g. Liquid Capacity: 52 gal (197 L).
  - h. Connection size (mechanical): 4 inches (102 mm).

## 2.4 SOLIDS INTERCEPTOR

### A. Product: Solids Interceptor as manufactured by Canplas Industries Ltd.

1. Parts in direct contact with flow shall be constructed of engineered thermoplastic capable of withstanding operational temperatures of 220 degree F (104 degree C). Baffles shall be perforated with slots as opposed circular perforations for enhanced straining of elongated debris e.g. mop strings, spaghetti etc. The solids interceptor shall be removable for cleaning and in operation have a minimum flow rate greater than 50 GPM (3.2 liter per second) when loaded to 50% of its solids-holding capacity. Any baffles/straining method used shall also be removable for maintenance and operation shall use a dual means of filtration on solid material within the flow. When installed in a stand-alone configuration the tank will meet the same specification as above and have both a lid which is airtight and capable of supporting 440 lb (220 kg).
2. Type: Stand Alone Model 3911A02: Solids Interceptor. Complete with Solids Basket Accessory (SBA): 2 inches (51 mm) inlet.

3. Type: Integral to Interceptor Model 3911A-1: Solids Basket Accessory (SBA).

## PART 3 EXECUTION

### 3.1 EXAMINATION

- A. Do not begin installation until substrates have been properly prepared.
- B. If substrate preparation is the responsibility of another installer, notify Architect of unsatisfactory preparation before proceeding.

### 3.2 PREPARATION

- A. Clean surfaces thoroughly prior to installation.
- B. Prepare surfaces using the methods recommended by the manufacturer for achieving the best result for the substrate under the project conditions.

### 3.3 INSTALLATION

- A. Install in accordance with manufacturer's instructions.
- B. Do not pressurize any interceptor as there is a serious risk of injury and death. The interceptor as an appurtenance shall be isolated for the purposes of leak testing the upstream and downstream drainage system when commissioning and verifying the system operation.
- C. Interceptor tank will be installed to the associated drainage system using mechanical joint couplings approved by the Authority Having Jurisdiction (AHJ). Supplied by others.
- D. When installing in-floor tanks will be filled to static water level with water to prevent movement and resist pressure of backfilling process.
- E. Cover will be secured in place during backfilling process to maintain structural rigidity and form and to prevent ingress of foreign bodies into both the interceptor and drainage system.

### 3.4 FIELD QUALITY CONTROL

- A. Provide inspection certificates of Authority Having Jurisdiction (AHJ).

### 3.5 PROTECTION

- A. Protect installed products until completion of project.
- B. Touch-up, repair or replace damaged products before Substantial Completion.

## END OF SECTION



# canplas®

*Molding a better future*



The Canplas manufacturing location in Barrie, Ontario, Canada is ISO 9001 and 14001 registered facility. Our quality management system has been registered for the design, manufacture and distribution of high quality injection molded products used in plumbing, industrial, ventilation and central vacuum applications.



[www.arcat.com](http://www.arcat.com)



[www.csc-dcc.ca](http://www.csc-dcc.ca)



[www.csinet.org](http://www.csinet.org)

**Canplas Industries Ltd.**

P.O. Box 1800, 500 Veterans Dr.  
Barrie, ON, Canada L4M 4V3  
Tel: (705) 726-3361  
Toll Free: 1-800-461-5300  
Fax: (705) 726-2186  
Toll Free Fax: 1-888-432-2201

**Canplas LLC**

11402 East 53rd Ave.  
Suite 200, Denver, CO, USA 80239  
Tel: (303) 373-1918  
Toll Free: 1-888-461-5307  
Fax: (303) 373-1923  
Toll Free Fax: 1-888-461-5309

[www.endurainterceptor.com](http://www.endurainterceptor.com)