

4HP14L

PRODUCT SPECIFICATIONS

14 SEER SPLIT SYSTEM HEAR PUMP

FORM NO. 4HP14L-100 (04/2014)



Features and Benefits

- R410A Refrigerant
- High-quality condenser coil with copper tubing and enhanced louvered fin for maximum heat transfer capacity
- Top discharge directs hot air and sound away from living area and shrubbery
- All units run tested
- Louvered panel coil protection
- Easy access to electrical panels, pre-wired for easy hook-up
- Bi-directional liquid line filter drier factory installed
- Discharge muffler for quiet operation
- Reliable, solid state defrost control
- Defrost control is Quiet Shift™ capable
- Low pressure switch factory installed for loss of charge protection
- Integrated control with LED diagnostics
- Short cycle protection factory installed
- All units ETL and ETL approved and AHRI Certified
- Charged for 15 feet of interconnecting tubing

Warranty

10 year limited warranty on compressor, 10 year limited warranty on all parts, extended warranty available*

*Warranty provides for a total of 10 years of limited warranty coverage (Standard 5-year limited parts warranty plus an additional 5-year limited extended parts warranty). Warranty must be registered online within 60 days of installation to qualify for 10-year coverage. Unregistered equipment defaults to 5-year coverage. Lifetime limited heat exchanger warranty applies to registered equipment only (Standard 20 years with no online registration). See full warranty at www.alliedair.com for terms, conditions and exclusions.



Proper sizing and installation of equipment is critical to achieve optimal performance. Split system air conditioners and heat pumps must be matched with appropriate coil components to meet ENERGY STAR® criteria. Visit www.energystar.gov for details.

Model Number Guide

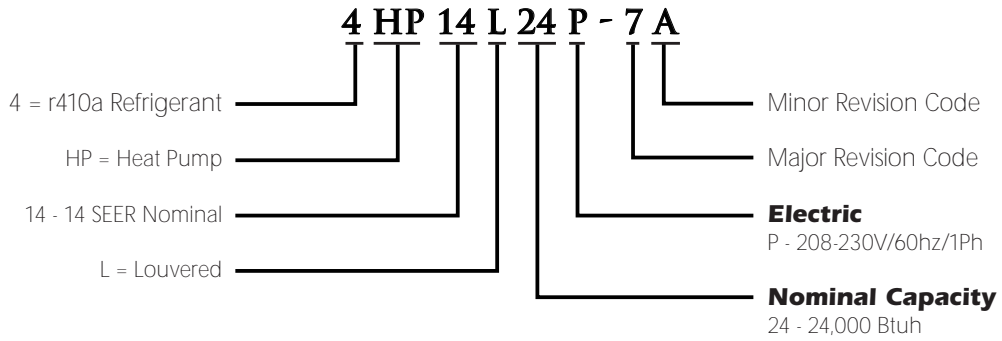

Physical and Electrical Data

Model	Volts/Hz/Phase	Voltage Range	Min. Circuit Amp.	Max. Over-current Device (amps)	Compressor		Outdoor Fan Motor			Refrig. Charge (oz.)	Shipping Weight (lbs.)	
					Rated Load (amps)	Locked Rotor (amps)	Rated Load (amps)	Rated HP	Nom. RPM		Wire Guard	Louver
4HP14L18P-7	208-230/60/1	197-253	12.3	20	9.0	48	1.1	1/6	825	87	NA	165
4HP14L24P-7	208-230/60/1	197-253	17.9	30	13.4	58	1.1	1/6	825	108	NA	177
4HP14L30P-7	208-230/60/1	197-253	17.1	25	12.8	64	1.1	1/6	825	110	NA	178
4HP14L36P-7	208-230/60/1	197-253	18.7	30	14.1	77	1.1	1/6	825	159	NA	202
4HP14L42P-7	208-230/60/1	197-253	24.2	40	17.9	112	1.8	1/3	825	184	NA	272
4HP14L48P-7	208-230/60/1	197-253	29.0	50	21.8	117	1.8	1/3	825	232	NA	273
4HP14L60P-7	208-230/60/1	197-253	29.4	50	22.1	125	1.8	1/3	825	228	NA	297

Note:
Weights listed are unit weights with packaging
+ Factory charged for 15 feet of line set. Adjust per installation instructions.

Unit Dimensions & Sound Ratings

Model	Dimensions			Sound Ratings (dBa)
	A (in.)	B (in.)	C (in.)	
4HP14L18P-7	28.25	28.25	29.00	76
4HP14L24P-7	28.25	28.25	37.00	76
4HP14L30P-7	28.25	28.25	37.00	76
4HP14L36P-7	28.25	28.25	33.00	76
4HP14L42P-7	32.25	32.25	37.00	79
4HP14L48P-7	32.25	32.25	37.00	80
4HP14L60P-7	32.25	32.25	43.00	80

Note:
Dimensions listed are unit sizes w/o packaging

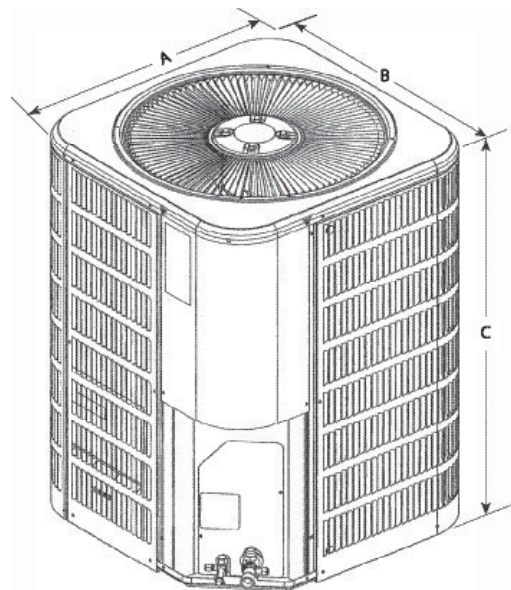

Cooling Performance with Evaporator Coils

Outdoor Model	Indoor Model	Cooling				Heating				CFM	Refrigerant Connection				Refrigerant Line Size		Indoor Expansion Device		
		SEER	EER	AHRI Rated Capacity ¹ BTUH	Sensible Capacity BTUH	HSPF	47		17		Outdoor		Indoor		Suction	Liquid	Piston ²	TXV	
	Butth						COP	Butth	COP		Suction	Liquid	Suction	Liquid					
																			Suction
4HP14L18P-7	E*1P23(A,B)	13.2	11.5	18,000	13,500	8.0	17,400	3.40	10,500	2.26	650	3/4	3/8	3/4	3/8	3/4	3/8	NA	H4TXV01
	E*1P24(A,B)	13.2	11.5	18,000	13,500	8.0	17,400	3.40	10,500	2.26	650	3/4	3/8	3/4	3/8	3/4	3/8	NA	H4TXV01
4HP14L24P-7	E*1P23(A,B)	14.0	12.0	23,400	17,100	8.0	22,000	3.40	14,000	2.30	850	3/4	3/8	3/4	3/8	3/4	3/8	NA	H4TXV01
	E*1P24(A,B)	14.0	11.5	23,400	17,100	8.2	22,000	3.40	14,000	2.30	850	3/4	3/8	3/4	3/8	3/4	3/8	NA	H4TXV01
	E*1P29(A,B)	14.0	11.5	23,400	17,100	8.2	22,000	3.40	14,000	2.30	850	3/4	3/8	3/4	3/8	3/4	3/8	NA	H4TXV01
4HP14L30P-7	E*1P29(A,B)	13.5	11.5	29,000	21,500	8.2	26,200	3.40	17,000	2.50	1050	3/4	3/8	3/4	3/8	3/4	3/8	NA	H4TXV01
	E*1P30(A,B,C)	13.2	11.5	28,000	20,700	8.2	26,200	3.40	16,000	2.30	1050	3/4	3/8	3/4	3/8	3/4	3/8	NA	H4TXV01
	E*1P36(A,B,C)	13.5	11.5	29,000	21,500	8.2	26,200	3.40	17,000	2.50	1050	3/4	3/8	3/4	3/8	3/4	3/8	NA	H4TXV01
4HP14L36P-7	E*1P36(B,C)	13.5	12.0	34,400	25,800	8.2	34,200	3.50	21,800	2.50	1250	7/8	3/8	3/4	3/8	7/8	3/8	NA	H4TXV02
	E*1P43(B,C)	13.5	11.5	34,400	25,800	8.2	34,000	3.50	21,800	2.40	1250	7/8	3/8	7/8	3/8	7/8	3/8	NA	H4TXV02
4HP14L42P-7	E*1P49C	14.0	12.0	42,000	30,700	8.2	42,000	3.50	27,800	2.40	1400	7/8	3/8	7/8	3/8	7/8	3/8	NA	H4TXV02
	E*1P62D	14.0	12.0	42,000	30,700	8.2	42,000	3.50	28,800	2.40	1400	7/8	3/8	7/8	3/8	7/8	3/8	NA	H4TXV02
4HP14L48P-7	E*1P49C	14.0	12.0	48,000	34,600	8.2	46,500	3.40	29,600	2.50	1600	7/8	3/8	7/8	3/8	7/8	3/8	NA	H4TXV02
	E*1P62D	14.0	12.0	48,000	34,600	8.2	46,500	3.40	29,600	2.50	1600	7/8	3/8	7/8	3/8	7/8	3/8	NA	H4TXV02
4HP14L60P-7	E*1P62C	14.0	12.0	58,000	42,300	8.2	55,000	3.40	36,000	2.50	1900	7/8	3/8	7/8	3/8	1 1/8	3/8	NA	H4TXV03
	E*1P62D	14.0	12.0	58,000	42,300	8.2	55,000	3.40	36,000	2.50	1900	7/8	3/8	7/8	3/8	1 1/8	3/8	NA	H4TXV03

Note:

¹ Certified in accordance with Unitary Air Conditioner Certification Program, which is based on AHRI Standard 210/240

² Required to achieve AHRI rating. If NA (Not Applicable) is in the piston column, then TXV is required.

³ A blower time delay relay is required to achieve AHRI rating. This feature is standard on all Allied Air Enterprises furnace and AH products.

Cooling Performance with Air Handlers and Furnaces 1-1/2 Ton

Outdoor Model	Indoor Model		Cooling				Heating				CFM	Refrigerant Connection				Refrig. Line Size		Indoor Expansion Device		
	Evaporator Coil or Air Handler ³	Furnace	SEER	EER	ARI Rated Capacity ¹ Btuh	Rated Sensible Capacity Btuh	HSPF	47		17		Outdoor		Indoor		Suction	Liquid	Piston ²	TXV	
								Btuh	COP	Btuh		COP	Suction	Liquid	Suction					Liquid
4HP14L18P-7	BCS2M18C****P+TXV		14.0	11.5	18,000	13,500	7.7	16,600	3.4	10,500	2.26	650	3/4	3/8	3/4	3/8	3/4	3/8	NA	H4TXV01
	BCS2M24V****P+TXV		15.0	12.5	18,000	13,500	8.0	16,600	3.4	10,100	2.20	650	3/4	3/8	3/4	3/8	3/4	3/8	NA	H4TXV01
	BCS3M18C****P+TXV		14.0	11.5	17,800	13,400	8.0	16,800	3.4	10,500	2.26	640	3/4	3/8	3/4	3/8	3/4	3/8	NA	H4TXV01
	BCS3M24E****P+H4TXV01		15.0	12.5	17,800	13,400	8.5	16,800	3.4	10,500	2.26	650	3/4	3/8	3/4	3/8	3/4	3/8	NA	H4TXV01
	E*1P23A+H4TXV01	80G2UH070AV12*	15.0	12.5	18,000	13,400	8.5	17,400	3.7	10,400	2.40	650	3/4	3/8	3/4	3/8	3/4	3/8	NA	H4TXV01
	E*1P23A+H4TXV01	80G1DF045AE12	14.5	12.0	18,000	13,400	8.5	17,400	3.7	10,400	2.40	650	3/4	3/8	3/4	3/8	3/4	3/8	NA	H4TXV01
	E*1P23A+H4TXV01	80G1UH045AE12	14.5	12.0	18,000	13,400	8.5	17,400	3.7	10,400	2.40	650	3/4	3/8	3/4	3/8	3/4	3/8	NA	H4TXV01
	E*1P23B+H4TXV01	80G2UH090BV16*	15.0	12.5	18,000	13,400	8.5	17,400	3.7	10,400	2.40	650	3/4	3/8	3/4	3/8	3/4	3/8	NA	H4TXV01
	E*1P23B+H4TXV01	EFV08BC	15.0	12.5	18,000	13,400	8.5	17,400	3.7	10,400	2.40	650	3/4	3/8	3/4	3/8	3/4	3/8	NA	H4TXV01
	E*1P23B+H4TXV01	80G1UH070BE12	14.5	12.0	18,000	13,400	8.5	17,400	3.7	10,400	2.40	650	3/4	3/8	3/4	3/8	3/4	3/8	NA	H4TXV01
	E*1P23B+H4TXV01	95G1DF045BE12	14.0	12.0	18,000	13,400	8.5	17,400	3.7	10,400	2.40	650	3/4	3/8	3/4	3/8	3/4	3/8	NA	H4TXV01
	E*1P23B+H4TXV01	95G2DF070BV16	14.5	12.5	18,000	13,400	8.5	17,400	3.7	10,400	2.40	650	3/4	3/8	3/4	3/8	3/4	3/8	NA	H4TXV01
	E*1P23B+H4TXV01	95G2DF045BV12	15.0	12.5	18,000	13,400	8.5	17,400	3.7	10,400	2.40	650	3/4	3/8	3/4	3/8	3/4	3/8	NA	H4TXV01
	E*1P23B+H4TXV01	80G1DF070BE12	14.5	12.0	18,000	13,400	8.5	17,400	3.7	10,400	2.40	650	3/4	3/8	3/4	3/8	3/4	3/8	NA	H4TXV01
	E*1P23B+H4TXV01	95G2UH070BV12	15.0	12.5	18,000	13,400	8.5	17,400	3.7	10,400	2.40	650	3/4	3/8	3/4	3/8	3/4	3/8	NA	H4TXV01
	E*1P23B+H4TXV01	95G1UH070BE12	14.5	12.0	18,000	13,400	8.5	17,400	3.7	10,400	2.40	650	3/4	3/8	3/4	3/8	3/4	3/8	NA	H4TXV01
	E*1P23B+H4TXV01	95G2UH045BV12	14.5	12.5	18,000	13,400	8.5	17,400	3.7	10,400	2.40	650	3/4	3/8	3/4	3/8	3/4	3/8	NA	H4TXV01
	E*1P23B+H4TXV01	95G1UH045BE12	14.0	12.0	18,000	13,400	8.5	17,400	3.7	10,400	2.40	650	3/4	3/8	3/4	3/8	3/4	3/8	NA	H4TXV01
	E*1P24A+H4TXV01	80G2UH070AV12*	15.0	12.5	18,000	13,400	8.2	17,400	3.7	10,400	2.40	650	3/4	3/8	3/4	3/8	3/4	3/8	NA	H4TXV01
	E*1P24A+H4TXV01	80G1DF045AE12	14.0	12.0	18,000	13,400	8.2	17,400	3.7	10,400	2.40	650	3/4	3/8	3/4	3/8	3/4	3/8	NA	H4TXV01
	E*1P24A+H4TXV01	80G1UH045AE12	14.5	12.0	18,000	13,400	8.2	17,400	3.7	10,400	2.40	650	3/4	3/8	3/4	3/8	3/4	3/8	NA	H4TXV01
	E*1P24B+H4TXV01	80G2UH090BV16*	15.0	12.5	18,000	13,400	8.2	17,400	3.7	10,400	2.40	650	3/4	3/8	3/4	3/8	3/4	3/8	NA	H4TXV01
	E*1P24B+H4TXV01	EFV08BC	15.0	12.5	18,000	13,400	8.2	17,400	3.7	10,400	2.40	650	3/4	3/8	3/4	3/8	3/4	3/8	NA	H4TXV01
	E*1P24B+H4TXV01	95G1DF045BE12	14.0	12.0	18,000	13,400	8.2	17,400	3.7	10,400	2.40	650	3/4	3/8	3/4	3/8	3/4	3/8	NA	H4TXV01
	E*1P24B+H4TXV01	95G2DF070BV16	14.5	12.5	18,000	13,400	8.2	17,400	3.7	10,400	2.40	650	3/4	3/8	3/4	3/8	3/4	3/8	NA	H4TXV01
	E*1P24B+H4TXV01	80G1UH070BE12	14.0	12.0	18,000	13,400	8.2	17,400	3.7	10,400	2.40	650	3/4	3/8	3/4	3/8	3/4	3/8	NA	H4TXV01
	E*1P24B+H4TXV01	95G1UH070BE12	14.0	12.0	18,000	13,400	8.2	17,400	3.7	10,400	2.40	650	3/4	3/8	3/4	3/8	3/4	3/8	NA	H4TXV01
	E*1P24B+H4TXV01	80G1DF070BE12	14.5	12.0	18,000	13,400	8.2	17,400	3.7	10,400	2.40	650	3/4	3/8	3/4	3/8	3/4	3/8	NA	H4TXV01
	E*1P24B+H4TXV01	95G2UH045BV12	14.5	12.5	18,000	13,400	8.2	17,400	3.7	10,400	2.40	650	3/4	3/8	3/4	3/8	3/4	3/8	NA	H4TXV01
	E*1P24B+H4TXV01	95G1UH045BE12	14.0	12.0	18,000	13,400	8.2	17,400	3.7	10,400	2.40	650	3/4	3/8	3/4	3/8	3/4	3/8	NA	H4TXV01
E*1P24B+H4TXV01	95G2DF045BV12	15.0	12.5	18,000	13,400	8.2	17,400	3.7	10,400	2.40	650	3/4	3/8	3/4	3/8	3/4	3/8	NA	H4TXV01	
E*1P24B+H4TXV01	95G2UH070BV12	15.0	12.5	18,000	13,400	8.2	17,400	3.7	10,400	2.40	650	3/4	3/8	3/4	3/8	3/4	3/8	NA	H4TXV01	

Note:
 1 Certified in accordance with Unitary Air Conditioner Certification Program, which is based on AHRI Standard 210/240
 2 Required to achieve AHRI rating. If NA (Not Applicable) is in the piston column, then TXV is required.
 3 A blower time delay relay is required to achieve AHRI rating. This feature is standard on all Allied Air Enterprises furnace and AH products

Cooling Performance with Air Handlers and Furnaces 2 Ton

Outdoor Model	Indoor Model		Cooling				Heating				CFM	Refrigerant Connection				Refrig. Line Size		Indoor Expansion Device		
	Evaporator Coil or Air Handler ³	Furnace	SEER	EER	ARI Rated Capacity ¹ Btuh	Rated Sensible Capacity Btuh	HSPF	47		17		Outdoor		Indoor		Suction	Liquid	Piston ²	TXV	
								Btuh	COP	Btuh		COP	Suction	Liquid	Suction					Liquid
4HP14L24P-7	BCS2M24C****P+TXV		14.0	12.0	23,400	17,100	8.2	22,000	3.4	14,000	2.30	850	3/4	3/8	3/4	3/8	3/4	3/8	NA	H4TXV01
	BCS2M24V****P+TXV		15.0	12.5	23,400	17,100	8.5	21,600	3.6	13,600	2.50	850	3/4	3/8	3/4	3/8	3/4	3/8	NA	H4TXV01
	BCS3M24C****P+TXV		14.0	12.0	23,400	17,100	8.2	21,600	3.4	14,000	2.30	850	3/4	3/8	7/8	3/8	3/4	3/8	NA	H4TXV01
	BCS3M30E****P+H4TXV01		15.0	12.5	23,400	17,100	8.5	21,600	3.4	14,000	2.3	850	3/4	3/8	7/8	3/8	3/4	3/8	NA	H4TXV01
	E*1P23A+H4TXV01	80G2UH070AV12*	15.0	12.5	23,400	17,100	8.2	21,600	3.6	14,000	2.50	850	3/4	3/8	3/4	3/8	3/4	3/8	NA	H4TXV01
	E*1P23A+H4TXV01	80G1UH045AE12	14.5	12.0	23,400	17,100	8.2	21,600	3.6	14,000	2.50	850	3/4	3/8	3/4	3/8	3/4	3/8	NA	H4TXV01
	E*1P23A+H4TXV01	80G1DF045AE12	15.0	12.5	23,400	17,100	8.2	21,600	3.6	14,000	2.50	850	3/4	3/8	3/4	3/8	3/4	3/8	NA	H4TXV01
	E*1P23B+H4TXV01	EFV088C	15.0	12.5	23,400	17,100	8.2	21,600	3.6	14,000	2.50	850	3/4	3/8	3/4	3/8	3/4	3/8	NA	H4TXV01
	E*1P23B+H4TXV01	80G2UH090BV16*	15.0	12.5	23,400	17,100	8.2	21,600	3.6	14,000	2.50	850	3/4	3/8	3/4	3/8	3/4	3/8	NA	H4TXV01
	E*1P23B+H4TXV01	95G1UH045BE12	14.5	12.0	23,400	17,100	8.2	21,600	3.6	14,000	2.50	850	3/4	3/8	3/4	3/8	3/4	3/8	NA	H4TXV01
	E*1P23B+H4TXV01	95G1UH070BE12	14.5	12.0	23,400	17,100	8.2	21,600	3.6	14,000	2.50	850	3/4	3/8	3/4	3/8	3/4	3/8	NA	H4TXV01
	E*1P23B+H4TXV01	80G1DF070BE12	15.0	12.5	23,400	17,100	8.2	21,600	3.6	14,000	2.50	850	3/4	3/8	3/4	3/8	3/4	3/8	NA	H4TXV01
	E*1P23B+H4TXV01	95G2UH070BV12	15.0	12.5	23,400	17,100	8.2	21,600	3.6	14,000	2.50	850	3/4	3/8	3/4	3/8	3/4	3/8	NA	H4TXV01
	E*1P23B+H4TXV01	95G2UH045BV12	15.0	12.5	23,400	17,100	8.2	21,600	3.6	14,000	2.50	850	3/4	3/8	3/4	3/8	3/4	3/8	NA	H4TXV01
	E*1P23B+H4TXV01	95G1DF045BE12	14.5	12.0	23,400	17,100	8.2	21,600	3.6	14,000	2.50	850	3/4	3/8	3/4	3/8	3/4	3/8	NA	H4TXV01
	E*1P23B+H4TXV01	95G2DF070BV16	15.0	12.5	23,400	17,100	8.2	21,600	3.6	14,000	2.50	850	3/4	3/8	3/4	3/8	3/4	3/8	NA	H4TXV01
	E*1P23B+H4TXV01	80G1UH070BE12	15.0	12.5	23,400	17,100	8.2	21,600	3.6	14,000	2.50	850	3/4	3/8	3/4	3/8	3/4	3/8	NA	H4TXV01
	E*1P23B+H4TXV01	95G2DF045BV12	15.0	12.5	23,400	17,100	8.2	21,600	3.6	14,000	2.50	850	3/4	3/8	3/4	3/8	3/4	3/8	NA	H4TXV01
	E*1P24A+H4TXV01	80G2UH070AV12*	15.0	12.5	23,400	17,100	8.5	21,600	3.6	14,000	2.50	850	3/4	3/8	3/4	3/8	3/4	3/8	NA	H4TXV01
	E*1P24A+H4TXV01	80G1UH045AE12	14.5	12.0	23,400	17,100	8.5	21,600	3.6	14,000	2.50	850	3/4	3/8	3/4	3/8	3/4	3/8	NA	H4TXV01
	E*1P24A+H4TXV01	80G1DF045AE12	15.0	12.5	23,400	17,100	8.5	21,600	3.6	14,000	2.50	850	3/4	3/8	3/4	3/8	3/4	3/8	NA	H4TXV01
	E*1P24B+H4TXV01	80G2UH090BV16*	15.0	12.5	23,400	17,100	8.5	21,600	3.6	14,000	2.50	850	3/4	3/8	3/4	3/8	3/4	3/8	NA	H4TXV01
	E*1P24B+H4TXV01	EFV088C	15.0	12.5	23,400	17,100	8.5	21,600	3.6	14,000	2.50	850	3/4	3/8	3/4	3/8	3/4	3/8	NA	H4TXV01
	E*1P24B+H4TXV01	80G1DF070BE12	15.0	12.5	23,400	17,100	8.5	21,600	3.6	14,000	2.50	850	3/4	3/8	3/4	3/8	3/4	3/8	NA	H4TXV01
	E*1P24B+H4TXV01	95G2UH070BV12	15.0	12.5	23,400	17,100	8.5	21,600	3.6	14,000	2.50	850	3/4	3/8	3/4	3/8	3/4	3/8	NA	H4TXV01
	E*1P24B+H4TXV01	80G1UH070BE12	15.0	12.5	23,400	17,100	8.5	21,600	3.6	14,000	2.50	850	3/4	3/8	3/4	3/8	3/4	3/8	NA	H4TXV01
	E*1P24B+H4TXV01	95G2DF045BV12	15.0	12.5	23,400	17,100	8.5	21,600	3.6	14,000	2.50	850	3/4	3/8	3/4	3/8	3/4	3/8	NA	H4TXV01
	E*1P24B+H4TXV01	95G1UH070BE12	14.5	12.0	23,400	17,100	8.5	21,600	3.6	14,000	2.50	850	3/4	3/8	3/4	3/8	3/4	3/8	NA	H4TXV01
	E*1P24B+H4TXV01	95G2UH045BV12	15.0	12.5	23,400	17,100	8.5	21,600	3.6	14,000	2.50	850	3/4	3/8	3/4	3/8	3/4	3/8	NA	H4TXV01
	E*1P24B+H4TXV01	95G1UH045BE12	14.5	12.0	23,400	17,100	8.5	21,600	3.6	14,000	2.50	850	3/4	3/8	3/4	3/8	3/4	3/8	NA	H4TXV01
	E*1P24B+H4TXV01	95G2DF070BV16	15.0	12.5	23,400	17,100	8.5	21,600	3.6	14,000	2.50	850	3/4	3/8	3/4	3/8	3/4	3/8	NA	H4TXV01
	E*1P24B+H4TXV01	95G1DF045BE12	14.5	12.0	23,400	17,100	8.5	21,600	3.6	14,000	2.50	850	3/4	3/8	3/4	3/8	3/4	3/8	NA	H4TXV01
E*1P24B+H4TXV01	95G2UH070BV12	15.0	12.5	18,000	13,400	8.2	17,400	3.7	10,400	2.40	650	3/4	3/8	3/4	3/8	3/4	3/8	NA	H4TXV01	

Note:
 1 Certified in accordance with Unitary Air Conditioner Certification Program, which is based on AHRI Standard 210/240
 2 Required to achieve AHRI rating. If NA (Not Applicable) is in the piston column, then TXV is required.
 3 A blower time delay relay is required to achieve AHRI rating. This feature is standard on all Allied Air Enterprises furnace and AH products

Cooling Performance with Air Handlers and Furnaces 2 Ton, 2-1/2 Ton

Outdoor Model	Indoor Model		Cooling				Heating				CFM	Refrigerant Connection				Refrig. Line Size		Indoor Expansion Device		
	Evaporator Coil or Air Handler ³	Furnace	SEER	EER	ARI Rated Capacity ¹ Btuh	Rated Sensible Capacity Btuh	HSPF	47		17		Outdoor		Indoor		Suction	Liquid	Piston ²	TXV	
								Btuh	COP	Btuh		COP	Suction	Liquid	Suction					Liquid
4HP14L24P-7	E*1P29A+H4TXV01	80G2UH070AV12*	15.0	12.5	23,400	17,100	8.5	21,600	3.6	14,000	2.50	850	3/4	3/8	3/4	3/8	3/4	3/8	NA	H4TXV01
	E*1P29A+H4TXV01	80G1DF045AE12	15.0	12.5	23,400	17,100	8.5	21,600	3.6	14,000	2.50	850	3/4	3/8	3/4	3/8	3/4	3/8	NA	H4TXV01
	E*1P29A+H4TXV01	80G1UH045AE12	14.5	12.0	23,400	17,100	8.5	21,600	3.6	14,000	2.50	850	3/4	3/8	3/4	3/8	3/4	3/8	NA	H4TXV01
	E*1P29B+H4TXV01	80G2UH090BV16*	15.0	12.5	23,400	17,100	8.5	21,600	3.6	14,000	2.50	850	3/4	3/8	3/4	3/8	3/4	3/8	NA	H4TXV01
	E*1P29B+H4TXV01	EFV08BC	15.0	12.5	23,400	17,100	8.5	21,600	3.6	14,000	2.50	850	3/4	3/8	3/4	3/8	3/4	3/8	NA	H4TXV01
	E*1P29B+H4TXV01	95G2DF045BV12	15.0	12.5	23,400	17,100	8.5	21,600	3.6	14,000	2.50	850	3/4	3/8	3/4	3/8	3/4	3/8	NA	H4TXV01
	E*1P29B+H4TXV01	95G2DF070BV16	15.0	12.5	23,400	17,100	8.5	21,600	3.6	14,000	2.50	850	3/4	3/8	3/4	3/8	3/4	3/8	NA	H4TXV01
	E*1P29B+H4TXV01	95G1DF045BE12	14.5	12.0	23,400	17,100	8.5	21,600	3.6	14,000	2.50	850	3/4	3/8	3/4	3/8	3/4	3/8	NA	H4TXV01
	E*1P29B+H4TXV01	80G1UH070BE12	15.0	12.5	23,400	17,100	8.5	21,600	3.6	14,000	2.50	850	3/4	3/8	3/4	3/8	3/4	3/8	NA	H4TXV01
	E*1P29B+H4TXV01	95G1UH070BE12	14.5	12.0	23,400	17,100	8.5	21,600	3.6	14,000	2.50	850	3/4	3/8	3/4	3/8	3/4	3/8	NA	H4TXV01
	E*1P29B+H4TXV01	80G1DF070BE12	15.0	12.5	23,400	17,100	8.5	21,600	3.6	14,000	2.50	850	3/4	3/8	3/4	3/8	3/4	3/8	NA	H4TXV01
	E*1P29B+H4TXV01	95G2UH070BV12	15.0	12.5	23,400	17,100	8.5	21,600	3.6	14,000	2.50	850	3/4	3/8	3/4	3/8	3/4	3/8	NA	H4TXV01
4HP14L30P-7	BCS2M30C****P+TXV		14.0	12.0	29,000	21,500	8.2	26,200	3.4	17,000	2.50	1,050	3/4	3/8	7/8	3/8	3/4	3/8	NA	H4TXV01
	BCS2M36V****P+TXV		15.0	12.5	29,000	21,500	8.5	26,200	3.6	17,000	2.50	1,050	3/4	3/8	7/8	3/8	3/4	3/8	NA	H4TXV01
	BCS3M30C****P+TXV		14.0	12.0	28,600	21,200	8.2	26,200	3.4	17,000	2.50	1,050	3/4	3/8	7/8	3/8	3/4	3/8	NA	H4TXV01
	BCS3M30E****P+H4TXV01		15.0	12.5	28,600	21,200	8.5	26,200	3.4	17,000	2.5	1,050	3/4	3/8	7/8	3/8	3/4	3/8	NA	H4TXV01
	E*1P29A+H4TXV01	80G2UH070AV12*	15.0	12.5	29,000	21,500	8.5	26,200	3.6	17,000	2.50	1,050	3/4	3/8	3/4	3/8	3/4	3/8	NA	H4TXV01
	E*1P29A+H4TXV01	80G1UH045AE12	14.0	12.0	29,000	21,500	8.2	26,200	3.5	17,000	2.50	1,050	3/4	3/8	3/4	3/8	3/4	3/8	NA	H4TXV01
	E*1P29A+H4TXV01	80G1DF045AE12	14.5	12.5	29,000	21,500	8.5	26,200	3.6	17,000	2.50	1,050	3/4	3/8	3/4	3/8	3/4	3/8	NA	H4TXV01
	E*1P29B+H4TXV01	80G2UH090BV16*	14.5	12.5	29,000	21,500	8.5	26,200	3.6	17,000	2.50	1,050	3/4	3/8	3/4	3/8	3/4	3/8	NA	H4TXV01
	E*1P29B+H4TXV01	EFV12BC	14.5	12.5	29,000	21,500	8.5	26,200	3.6	17,000	2.50	1,050	3/4	3/8	3/4	3/8	3/4	3/8	NA	H4TXV01
	E*1P29B+H4TXV01	95G2DF070BV16	14.0	12.0	29,000	21,500	8.5	26,200	3.6	17,000	2.50	1,050	3/4	3/8	3/4	3/8	3/4	3/8	NA	H4TXV01
	E*1P29B+H4TXV01	95G2UH045BV12	14.0	12.0	29,000	21,500	8.5	26,200	3.6	17,000	2.50	1,050	3/4	3/8	3/4	3/8	3/4	3/8	NA	H4TXV01
	E*1P29B+H4TXV01	80G1UH070BE12	14.5	12.5	29,000	21,500	8.5	26,200	3.6	17,000	2.50	1,050	3/4	3/8	3/4	3/8	3/4	3/8	NA	H4TXV01
	E*1P29B+H4TXV01	95G2DF045BV12	14.5	12.5	29,000	21,500	8.5	26,200	3.6	17,000	2.50	1,050	3/4	3/8	3/4	3/8	3/4	3/8	NA	H4TXV01
	E*1P29B+H4TXV01	95G2UH070BV12	14.5	12.5	29,000	21,500	8.5	26,200	3.6	17,000	2.50	1,050	3/4	3/8	3/4	3/8	3/4	3/8	NA	H4TXV01
	E*1P29B+H4TXV01	80G1UH090BE16	14.5	12.5	29,000	21,500	8.5	26,200	3.5	17,000	2.50	1,050	3/4	3/8	3/4	3/8	3/4	3/8	NA	H4TXV01
	E*1P29B+H4TXV01	95G1UH070BE12	14.0	12.0	29,000	21,500	8.5	26,200	3.5	17,000	2.50	1,050	3/4	3/8	3/4	3/8	3/4	3/8	NA	H4TXV01
	E*1P29B+H4TXV01	95G1UH045BE12	14.0	12.0	29,000	21,500	8.5	26,200	3.6	17,000	2.50	1,050	3/4	3/8	3/4	3/8	3/4	3/8	NA	H4TXV01
	E*1P29B+H4TXV01	80G1DF090BE16	14.5	12.5	29,000	21,500	8.5	26,200	3.6	17,000	2.50	1,050	3/4	3/8	3/4	3/8	3/4	3/8	NA	H4TXV01

Note:
 1 Certified in accordance with Unitary Air Conditioner Certification Program, which is based on AHRI Standard 210/240
 2 Required to achieve AHRI rating. If NA (Not Applicable) is in the piston column, then TXV is required.
 3 A blower time delay relay is required to achieve AHRI rating. This feature is standard on all Allied Air Enterprises furnace and AH products

Cooling Performance with Air Handlers and Furnaces 2-1/2 Ton

Outdoor Model	Indoor Model		Cooling				Heating				CFM	Refrigerant Connection				Refrig. Line Size		Indoor Expansion Device		
			SEER	EER	ARI Rated Capacity ¹ Btuh	Rated Sensible Capacity Btuh	HSPF	47		17		Outdoor		Indoor		Suction	Liquid	Piston ²	TXV	
	Btuh	COP						Btuh	COP	Suction		Liquid	Suction	Liquid						
	Evaporator Coil or Air Handler ³	Furnace																		
4HP14L30P-7	E*1P29B+H4TXV01	95G1DF070BE16	14.0	12.0	29,000	21,500	8.5	26,200	3.6	17,000	2.50	1,050	3/4	3/8	3/4	3/8	3/4	3/8	NA	H4TXV01
	E*1P29B+H4TXV01	80G1DF070BE12	14.5	12.5	29,000	21,500	8.5	26,200	3.6	17,000	2.50	1,050	3/4	3/8	3/4	3/8	3/4	3/8	NA	H4TXV01
	E*1P29B+H4TXV01	95G1DF045BE12	14.0	12.0	29,000	21,500	8.5	26,200	3.6	17,000	2.50	1,050	3/4	3/8	3/4	3/8	3/4	3/8	NA	H4TXV01
	E*1P30A+H4TXV01	80G2UH070AV12*	14.5	12.5	28,000	20,700	8.5	26,200	3.6	15,600	2.40	1,050	3/4	3/8	3/4	3/8	3/4	3/8	NA	H4TXV01
	E*1P30A+H4TXV01	80G1UH045AE12	13.5	11.5	28,000	20,700	8.2	26,200	3.5	15,600	2.30	1,050	3/4	3/8	3/4	3/8	3/4	3/8	NA	H4TXV01
	E*1P30A+H4TXV01	80G1DF045AE12	14.0	12.0	28,000	20,700	8.5	26,200	3.6	15,600	2.40	1,050	3/4	3/8	3/4	3/8	3/4	3/8	NA	H4TXV01
	E*1P30B+H4TXV01	80G2UH090BV16*	14.0	12.0	28,000	20,700	8.5	26,200	3.6	15,600	2.30	1,050	3/4	3/8	3/4	3/8	3/4	3/8	NA	H4TXV01
	E*1P30B+H4TXV01	EFV12BC	14.0	12.0	28,000	20,700	8.5	26,200	3.6	15,600	2.40	1,050	3/4	3/8	3/4	3/8	3/4	3/8	NA	H4TXV01
	E*1P30B+H4TXV01	80G1UH090BE16	14.0	12.0	28,000	20,700	8.5	26,200	3.5	15,600	2.30	1,050	3/4	3/8	3/4	3/8	3/4	3/8	NA	H4TXV01
	E*1P30B+H4TXV01	95G2UH070BV12	14.0	12.0	28,000	20,700	8.5	26,200	3.6	15,600	2.40	1,050	3/4	3/8	3/4	3/8	3/4	3/8	NA	H4TXV01
	E*1P30B+H4TXV01	95G1DF045BE12	14.0	12.0	28,000	20,700	8.2	26,200	3.6	15,600	2.40	1,050	3/4	3/8	3/4	3/8	3/4	3/8	NA	H4TXV01
	E*1P30B+H4TXV01	80G1DF070BE12	14.0	12.0	28,000	20,700	8.5	26,200	3.6	15,600	2.40	1,050	3/4	3/8	3/4	3/8	3/4	3/8	NA	H4TXV01
	E*1P30B+H4TXV01	95G2DF045BV12	14.0	12.0	28,000	20,700	8.5	26,200	3.6	15,600	2.40	1,050	3/4	3/8	3/4	3/8	3/4	3/8	NA	H4TXV01
	E*1P30B+H4TXV01	95G1UH070BE12	13.5	11.5	28,000	20,700	8.5	26,200	3.5	15,600	2.30	1,050	3/4	3/8	3/4	3/8	3/4	3/8	NA	H4TXV01
	E*1P30B+H4TXV01	80G1UH070BE12	14.0	12.0	28,000	20,700	8.5	26,200	3.6	15,600	2.40	1,050	3/4	3/8	3/4	3/8	3/4	3/8	NA	H4TXV01
	E*1P30B+H4TXV01	95G2UH045BV12	14.0	12.0	28,000	20,700	8.5	26,200	3.6	15,600	2.40	1,050	3/4	3/8	3/4	3/8	3/4	3/8	NA	H4TXV01
	E*1P30B+H4TXV01	95G1UH045BE12	14.0	12.0	28,000	20,700	8.2	26,200	3.6	15,600	2.40	1,050	3/4	3/8	3/4	3/8	3/4	3/8	NA	H4TXV01
	E*1P30B+H4TXV01	80G1DF090BE16	14.0	12.0	28,000	20,700	8.5	26,200	3.6	15,600	2.40	1,050	3/4	3/8	3/4	3/8	3/4	3/8	NA	H4TXV01
	E*1P30B+H4TXV01	95G2DF070BV16	14.0	12.0	28,000	20,700	8.2	26,200	3.6	15,600	2.40	1,050	3/4	3/8	3/4	3/8	3/4	3/8	NA	H4TXV01
	E*1P30B+H4TXV01	95G1DF070BE16	14.0	12.0	28,000	20,700	8.2	26,200	3.6	15,600	2.40	1,050	3/4	3/8	3/4	3/8	3/4	3/8	NA	H4TXV01
	E*1P30C+H4TXV01	EFV16CC	14.5	12.5	28,000	20,700	8.5	26,200	3.6	15,600	2.40	1,050	3/4	3/8	3/4	3/8	3/4	3/8	NA	H4TXV01
	E*1P30C+H4TXV01	95G1DF090CE16	14.0	12.0	28,000	20,700	8.5	26,200	3.6	15,600	2.40	1,050	3/4	3/8	3/4	3/8	3/4	3/8	NA	H4TXV01
	E*1P30C+H4TXV01	95G2UH090CV12	14.5	12.5	28,000	20,700	8.5	26,200	3.6	15,600	2.40	1,050	3/4	3/8	3/4	3/8	3/4	3/8	NA	H4TXV01
	E*1P30C+H4TXV01	95G2DF110CV20	14.0	12.0	28,000	20,700	8.5	26,200	3.6	15,600	2.40	1,050	3/4	3/8	3/4	3/8	3/4	3/8	NA	H4TXV01
	E*1P30C+H4TXV01	95G2DF090CV20	14.5	12.0	28,000	20,700	8.5	26,200	3.6	15,600	2.40	1,050	3/4	3/8	3/4	3/8	3/4	3/8	NA	H4TXV01
	E*1P30C+H4TXV01	95G1UH090CE16	14.5	12.0	28,000	20,700	8.5	26,200	3.6	15,600	2.40	1,050	3/4	3/8	3/4	3/8	3/4	3/8	NA	H4TXV01
	E*1P36A+H4TXV01	80G2UH070AV12*	15.0	12.5	29,000	21,500	8.5	26,200	3.6	17,000	2.50	1,050	3/4	3/8	3/4	3/8	3/4	3/8	NA	H4TXV01
	E*1P36A+H4TXV01	80G1DF045AE12	14.5	12.5	29,000	21,500	8.5	26,200	3.6	17,000	2.50	1,050	3/4	3/8	3/4	3/8	3/4	3/8	NA	H4TXV01
	E*1P36B+H4TXV01	80G2UH090BV16*	14.5	12.5	29,000	21,500	8.5	26,200	3.6	17,000	2.50	1,050	3/4	3/8	3/4	3/8	3/4	3/8	NA	H4TXV01
	E*1P36B+H4TXV01	EFV12BC	14.5	12.5	29,000	21,500	8.5	26,200	3.6	17,000	2.50	1,050	3/4	3/8	3/4	3/8	3/4	3/8	NA	H4TXV01
E*1P36B+H4TXV01	80G1DF090BE16	14.5	12.5	29,000	21,500	8.5	26,200	3.6	17,000	2.50	1,050	3/4	3/8	3/4	3/8	3/4	3/8	NA	H4TXV01	

Note:
 1 Certified in accordance with Unitary Air Conditioner Certification Program, which is based on AHRI Standard 210/240
 2 Required to achieve AHRI rating. If NA (Not Applicable) is in the piston column, then TXV is required.
 3 A blower time delay relay is required to achieve AHRI rating. This feature is standard on all Allied Air Enterprises furnace and AH products

Cooling Performance with Air Handlers and Furnaces 2-1/2 Ton, 3 Ton

Outdoor Model	Indoor Model		Cooling				Heating				CFM	Refrigerant Connection				Refrig. Line Size		Indoor Expansion Device		
			SEER	EER	ARI Rated Capacity ¹ Btuh	Rated Sensible Capacity Btuh	HSPF	47		17		Outdoor		Indoor		Suction	Liquid	Piston ²	TXV	
	Btuh	COP						Btuh	COP	Suction		Liquid	Suction	Liquid						
	Evaporator Coil or Air Handler ³	Furnace																		
4HP14L30P-7	E*1P36B+H4TXV01	95G1DF070BE16	14.0	12.0	29,000	21,500	8.5	26,200	3.6	17,000	2.50	1,050	3/4	3/8	3/4	3/8	3/4	3/8	NA	H4TXV01
	E*1P36B+H4TXV01	95G2DF070BV16	14.0	12.0	29,000	21,500	8.5	26,200	3.6	17,000	2.50	1,050	3/4	3/8	3/4	3/8	3/4	3/8	NA	H4TXV01
	E*1P36B+H4TXV01	95G2DF045BV12	14.5	12.5	29,000	21,500	8.5	26,200	3.6	17,000	2.50	1,050	3/4	3/8	3/4	3/8	3/4	3/8	NA	H4TXV01
	E*1P36B+H4TXV01	80G1UH070BE12	14.5	12.5	29,000	21,500	8.5	26,200	3.6	17,000	2.50	1,050	3/4	3/8	3/4	3/8	3/4	3/8	NA	H4TXV01
	E*1P36B+H4TXV01	80G1DF070BE12	14.5	12.5	29,000	21,500	8.5	26,200	3.6	17,000	2.50	1,050	3/4	3/8	3/4	3/8	3/4	3/8	NA	H4TXV01
	E*1P36B+H4TXV01	95G2UH070BV12	14.5	12.5	29,000	21,500	8.5	26,200	3.6	17,000	2.50	1,050	3/4	3/8	3/4	3/8	3/4	3/8	NA	H4TXV01
	E*1P36B+H4TXV01	95G1UH070BE12	14.0	12.0	29,000	21,500	8.5	26,200	3.5	17,000	2.50	1,050	3/4	3/8	3/4	3/8	3/4	3/8	NA	H4TXV01
	E*1P36B+H4TXV01	95G2UH045BV12	14.0	12.5	29,000	21,500	8.5	26,200	3.6	17,000	2.50	1,050	3/4	3/8	3/4	3/8	3/4	3/8	NA	H4TXV01
	E*1P36B+H4TXV01	95G1UH045BE12	14.0	12.0	29,000	21,500	8.5	26,200	3.6	17,000	2.50	1,050	3/4	3/8	3/4	3/8	3/4	3/8	NA	H4TXV01
	E*1P36B+H4TXV01	80G1UH090BE16	14.0	12.0	29,000	21,500	8.5	26,200	3.5	17,000	2.50	1,050	3/4	3/8	3/4	3/8	3/4	3/8	NA	H4TXV01
	E*1P36B+H4TXV01	95G1DF045BE12	14.0	12.0	29,000	21,500	8.5	26,200	3.6	17,000	2.50	1,050	3/4	3/8	3/4	3/8	3/4	3/8	NA	H4TXV01
	E*1P36C+H4TXV01	EFV16CC	14.5	12.5	29,000	21,500	8.5	26,200	3.6	17,000	2.50	1,050	3/4	3/8	3/4	3/8	3/4	3/8	NA	H4TXV01
	E*1P36C+H4TXV01	95G1DF090CE16	14.5	12.5	29,000	21,500	8.5	26,200	3.6	17,000	2.50	1,050	3/4	3/8	3/4	3/8	3/4	3/8	NA	H4TXV01
	E*1P36C+H4TXV01	95G1UH090CE16	14.5	12.5	29,000	21,500	8.5	26,200	3.6	17,000	2.50	1,050	3/4	3/8	3/4	3/8	3/4	3/8	NA	H4TXV01
	E*1P36C+H4TXV01	95G2UH090CV12	15.0	12.5	29,000	21,500	8.5	26,200	3.6	17,000	2.50	1,050	3/4	3/8	3/4	3/8	3/4	3/8	NA	H4TXV01
	E*1P36C+H4TXV01	95G2DF110CV20	14.5	12.5	29,000	21,500	8.5	26,200	3.6	17,000	2.50	1,050	3/4	3/8	3/4	3/8	3/4	3/8	NA	H4TXV01
E*1P36C+H4TXV01	95G2DF090CV20	14.5	12.5	29,000	21,500	8.5	26,200	3.6	17,000	2.50	1,050	3/4	3/8	3/4	3/8	3/4	3/8	NA	H4TXV01	
4HP14L36P-7	BCS2M36C****P+TXV		14.0	12.0	34,400	25,800	8.2	34,200	3.5	21,800	2.50	1,250	7/8	3/8	7/8	3/8	7/8	3/8	NA	H4TXV02
	BCS2M36V****P+TXV		15.0	12.5	34,600	26,000	8.5	34,000	3.6	21,600	2.50	1,250	7/8	3/8	7/8	3/8	7/8	3/8	NA	H4TXV02
	BCS3M36C****P+TXV		14.0	12.0	34,000	25,500	8.2	33,800	3.5	21,800	2.50	1,250	7/8	3/8	7/8	3/8	7/8	3/8	NA	H4TXV02
	BCS3M36****P+H4TXV02		15.0	12.5	34,000	25,500	8.5	33,800	3.5	21,800	2.50	1,250	7/8	3/8	7/8	3/8	7/8	3/8	NA	H4TXV02
	E*1P36A+H4TXV02	80G2UH070AV12*	14.5	12.5	34,600	26,000	8.5	34,000	3.6	21,200	2.50	1,250	7/8	3/8	3/4	3/8	7/8	3/8	NA	H4TXV02
	E*1P36A+H4TXV02	80G1DF045AE12	14.0	12.5	34,600	26,000	8.2	34,000	3.6	21,200	2.50	1,250	7/8	3/8	3/4	3/8	7/8	3/8	NA	H4TXV02
	E*1P36B+H4TXV02	80G2UH090BV16*	14.0	12.5	34,600	26,000	8.5	34,000	3.6	21,200	2.40	1,250	7/8	3/8	3/4	3/8	7/8	3/8	NA	H4TXV02
	E*1P36B+H4TXV02	EFV12BC	14.5	12.5	34,600	26,000	8.5	34,000	3.6	21,200	2.50	1,250	7/8	3/8	3/4	3/8	7/8	3/8	NA	H4TXV02
	E*1P36B+H4TXV02	80G1UH070BE12	14.0	12.5	34,600	26,000	8.2	34,000	3.6	21,200	2.50	1,250	7/8	3/8	3/4	3/8	7/8	3/8	NA	H4TXV02
	E*1P36B+H4TXV02	80G1UH090BE16	14.5	12.5	34,600	26,000	8.5	34,000	3.6	21,200	2.50	1,250	7/8	3/8	3/4	3/8	7/8	3/8	NA	H4TXV02
	E*1P36B+H4TXV02	95G2UH045BV12	14.0	12.0	34,600	26,000	8.2	34,000	3.6	21,200	2.50	1,250	7/8	3/8	3/4	3/8	7/8	3/8	NA	H4TXV02
	E*1P36B+H4TXV02	95G2DF070BV16	14.0	12.0	34,600	26,000	8.2	34,000	3.6	21,200	2.50	1,250	7/8	3/8	3/4	3/8	7/8	3/8	NA	H4TXV02
	E*1P36B+H4TXV02	80G1DF090BE16	14.0	12.0	34,600	26,000	8.5	34,000	3.6	21,200	2.40	1,250	7/8	3/8	3/4	3/8	7/8	3/8	NA	H4TXV02
	E*1P36B+H4TXV02	95G2DF045BV12	14.0	12.0	34,600	26,000	8.2	34,000	3.6	21,200	2.50	1,250	7/8	3/8	3/4	3/8	7/8	3/8	NA	H4TXV02
	E*1P36B+H4TXV02	80G1DF070BE12	14.0	12.5	34,600	26,000	8.2	34,000	3.6	21,200	2.50	1,250	7/8	3/8	3/4	3/8	7/8	3/8	NA	H4TXV02

Note:
 1 Certified in accordance with Unitary Air Conditioner Certification Program, which is based on AHRI Standard 210/240
 2 Required to achieve AHRI rating. If NA (Not Applicable) is in the piston column, then TXV is required.
 3 A blower time delay relay is required to achieve AHRI rating. This feature is standard on all Allied Air Enterprises furnace and AH products

Cooling Performance with Air Handlers and Furnaces 3 Ton

Outdoor Model	Indoor Model		Cooling				Heating				CFM	Refrigerant Connection				Refrig. Line Size		Indoor Expansion Device		
	Evaporator Coil or Air Handler ³	Furnace	SEER	EER	ARI Rated Capacity ¹ Btuh	Rated Sensible Capacity Btuh	HSPF	47		17		Suction	Liquid	Suction	Liquid	Suction	Liquid	Piston ²	TXV	
								Btuh	COP	Btuh										COP
4HP14L36P-7	E*1P36B+H4TXV02	95G2UH070BV12	14.0	12.5	34,600	26,000	8.2	34,000	3.6	21,200	2.50	1,250	7/8	3/8	3/4	3/8	7/8	3/8	NA	H4TXV02
	E*1P36B+H4TXV02	95G1DF045BE12	14.0	12.0	34,600	26,000	8.2	34,000	3.6	21,200	2.50	1,250	7/8	3/8	3/4	3/8	7/8	3/8	NA	H4TXV02
	E*1P36C+H4TXV02	80G2UH110CV20*	14.5	12.5	34,600	26,000	8.5	34,000	3.6	21,200	2.50	1,250	7/8	3/8	3/4	3/8	7/8	3/8	NA	H4TXV02
	E*1P36C+H4TXV02	EFV16CC	15.0	12.5	34,600	26,000	8.5	34,000	3.6	21,000	2.50	1,250	7/8	3/8	3/4	3/8	7/8	3/8	NA	H4TXV02
	E*1P36C+H4TXV02	80G1UH090CE20	14.0	12.5	34,600	26,000	8.5	34,000	3.6	21,200	2.40	1,250	7/8	3/8	3/4	3/8	7/8	3/8	NA	H4TXV02
	E*1P36C+H4TXV02	95G2UH090CV12	14.5	12.5	34,600	26,000	8.2	34,000	3.6	21,200	2.50	1,250	7/8	3/8	3/4	3/8	7/8	3/8	NA	H4TXV02
	E*1P36C+H4TXV02	80G1UH110CE20	14.0	12.5	34,600	26,000	8.5	34,000	3.6	21,200	2.40	1,250	7/8	3/8	3/4	3/8	7/8	3/8	NA	H4TXV02
	E*1P36C+H4TXV02	95G2UH090CV20	14.5	12.5	34,600	26,000	8.5	34,000	3.6	21,200	2.50	1,250	7/8	3/8	3/4	3/8	7/8	3/8	NA	H4TXV02
	E*1P36C+H4TXV02	95G1UH110CE20	14.0	12.0	34,600	26,000	8.5	34,000	3.6	21,200	2.40	1,250	7/8	3/8	3/4	3/8	7/8	3/8	NA	H4TXV02
	E*1P36C+H4TXV02	95G1UH090CE16	14.0	12.5	34,600	26,000	8.2	34,000	3.6	21,200	2.50	1,250	7/8	3/8	3/4	3/8	7/8	3/8	NA	H4TXV02
	E*1P36C+H4TXV02	80G1DF110CE20	14.0	12.5	34,600	26,000	8.5	34,000	3.6	21,200	2.40	1,250	7/8	3/8	3/4	3/8	7/8	3/8	NA	H4TXV02
	E*1P36C+H4TXV02	95G2DF110CV20	14.0	12.5	34,600	26,000	8.2	34,000	3.6	21,200	2.50	1,250	7/8	3/8	3/4	3/8	7/8	3/8	NA	H4TXV02
	E*1P36C+H4TXV02	95G1DF110CE20	14.0	12.0	34,600	26,000	8.5	34,000	3.6	21,200	2.40	1,250	7/8	3/8	3/4	3/8	7/8	3/8	NA	H4TXV02
	E*1P36C+H4TXV02	95G2DF090CV20	14.5	12.5	34,600	26,000	8.2	34,000	3.6	21,200	2.50	1,250	7/8	3/8	3/4	3/8	7/8	3/8	NA	H4TXV02
	E*1P36C+H4TXV02	95G1DF090CE16	14.0	12.0	34,600	26,000	8.2	34,000	3.6	21,200	2.50	1,250	7/8	3/8	3/4	3/8	7/8	3/8	NA	H4TXV02
	E*1P36C+H4TXV02	95G2UH110CV20	14.5	12.5	34,600	26,000	8.5	34,000	3.6	21,200	2.50	1,250	7/8	3/8	3/4	3/8	7/8	3/8	NA	H4TXV02
	E*1P43B+H4TXV02	80G2UH090BV16*	14.0	12.0	34,600	26,000	8.5	34,000	3.6	21,800	2.40	1,250	7/8	3/8	7/8	3/8	7/8	3/8	NA	H4TXV02
	E*1P43B+H4TXV02	EFV12BC	14.5	12.5	34,600	26,000	8.5	34,000	3.6	21,800	2.50	1,250	7/8	3/8	7/8	3/8	7/8	3/8	NA	H4TXV02
	E*1P43B+H4TXV02	95G2DF045BV12	14.0	12.0	34,600	26,000	8.5	34,000	3.6	21,800	2.50	1,250	7/8	3/8	7/8	3/8	7/8	3/8	NA	H4TXV02
	E*1P43B+H4TXV02	95G2DF070BV16	14.0	12.0	34,600	26,000	8.5	34,000	3.6	21,800	2.50	1,250	7/8	3/8	7/8	3/8	7/8	3/8	NA	H4TXV02
	E*1P43B+H4TXV02	80G1UH070BE12	14.0	12.0	34,600	26,000	8.5	34,000	3.6	21,800	2.50	1,250	7/8	3/8	7/8	3/8	7/8	3/8	NA	H4TXV02
	E*1P43B+H4TXV02	80G1DF090BE16	14.0	12.0	34,600	26,000	8.5	34,000	3.6	21,800	2.50	1,250	7/8	3/8	7/8	3/8	7/8	3/8	NA	H4TXV02
	E*1P43B+H4TXV02	95G1DF045BE12	14.0	12.0	34,600	26,000	8.5	34,000	3.6	21,800	2.50	1,250	7/8	3/8	7/8	3/8	7/8	3/8	NA	H4TXV02
	E*1P43B+H4TXV02	80G1DF070BE12	14.0	12.0	34,600	26,000	8.5	34,000	3.6	21,800	2.50	1,250	7/8	3/8	7/8	3/8	7/8	3/8	NA	H4TXV02
	E*1P43B+H4TXV02	95G2UH070BV12	14.0	12.0	34,600	26,000	8.5	34,000	3.6	21,800	2.50	1,250	7/8	3/8	7/8	3/8	7/8	3/8	NA	H4TXV02
	E*1P43B+H4TXV02	80G1UH090BE16	14.5	12.5	34,600	26,000	8.5	34,000	3.6	21,800	2.50	1,250	7/8	3/8	7/8	3/8	7/8	3/8	NA	H4TXV02
	E*1P43B+H4TXV02	95G2UH045BV12	14.0	12.0	34,600	26,000	8.5	34,000	3.6	21,800	2.50	1,250	7/8	3/8	7/8	3/8	7/8	3/8	NA	H4TXV02
	E*1P43C+H4TXV02	80G2UH110CV20*	14.5	12.5	34,600	26,000	8.5	34,000	3.6	21,800	2.50	1,250	7/8	3/8	7/8	3/8	7/8	3/8	NA	H4TXV02
	E*1P43C+H4TXV02	EFV16CC	15.0	12.5	34,600	26,000	8.5	34,000	3.6	21,800	2.50	1,250	7/8	3/8	7/8	3/8	7/8	3/8	NA	H4TXV02
	E*1P43C+H4TXV02	80G1UH090CE20	14.5	12.5	34,600	26,000	8.5	34,000	3.6	21,800	2.50	1,250	7/8	3/8	7/8	3/8	7/8	3/8	NA	H4TXV02
E*1P43C+H4TXV02	80G1DF110CE20	14.5	12.5	34,600	26,000	8.5	34,000	3.6	21,800	2.50	1,250	7/8	3/8	7/8	3/8	7/8	3/8	NA	H4TXV02	

Note:
 1 Certified in accordance with Unitary Air Conditioner Certification Program, which is based on AHRI Standard 210/240
 2 Required to achieve AHRI rating. If NA (Not Applicable) is in the piston column, then TXV is required.
 3 A blower time delay relay is required to achieve AHRI rating. This feature is standard on all Allied Air Enterprises furnace and AH products

Cooling Performance with Air Handlers and Furnaces 3 Ton, 3-1/2 Ton

Outdoor Model	Indoor Model		Cooling				Heating				CFM	Refrigerant Connection				Refrig. Line Size		Indoor Expansion Device		
			SEER	EER	ARI Rated Capacity ¹ Btuh	Rated Sensible Capacity Btuh	HSPF	47		17		Outdoor		Indoor		Suction	Liquid	Piston ²	TXV	
	Btuh	COP						Btuh	COP	Suction		Liquid	Suction	Liquid						
	Evaporator Coil or Air Handler ³	Furnace																		
4HP14L36P-7	E*1P43C+H4TXV02	95G1DF110CE20	14.0	12.0	34,600	26,000	8.5	34,000	3.6	21,800	2.50	1,250	7/8	3/8	7/8	3/8	7/8	3/8	NA	H4TXV02
	E*1P43C+H4TXV02	95G1UH090CE16	14.0	12.0	34,600	26,000	8.5	34,000	3.6	21,800	2.50	1,250	7/8	3/8	7/8	3/8	7/8	3/8	NA	H4TXV02
	E*1P43C+H4TXV02	95G2UH090CV12	14.5	12.5	34,600	26,000	8.5	34,000	3.6	21,800	2.50	1,250	7/8	3/8	7/8	3/8	7/8	3/8	NA	H4TXV02
	E*1P43C+H4TXV02	95G2DF110CV20	14.0	12.5	34,600	26,000	8.5	34,000	3.6	21,800	2.50	1,250	7/8	3/8	7/8	3/8	7/8	3/8	NA	H4TXV02
	E*1P43C+H4TXV02	95G1DF090CE16	14.0	12.0	34,600	26,000	8.5	34,000	3.6	21,800	2.50	1,250	7/8	3/8	7/8	3/8	7/8	3/8	NA	H4TXV02
	E*1P43C+H4TXV02	95G2UH110CV20	14.5	12.5	34,600	26,000	8.5	34,000	3.6	21,800	2.50	1,250	7/8	3/8	7/8	3/8	7/8	3/8	NA	H4TXV02
	E*1P43C+H4TXV02	95G2DF090CV20	14.0	12.5	34,600	26,000	8.5	34,000	3.6	21,800	2.50	1,250	7/8	3/8	7/8	3/8	7/8	3/8	NA	H4TXV02
	E*1P43C+H4TXV02	80G1UH110CE20	14.5	12.5	34,600	26,000	8.5	34,000	3.6	21,800	2.50	1,250	7/8	3/8	7/8	3/8	7/8	3/8	NA	H4TXV02
	E*1P43C+H4TXV02	95G2UH090CV20	14.5	12.5	34,600	26,000	8.5	34,000	3.6	21,800	2.50	1,250	7/8	3/8	7/8	3/8	7/8	3/8	NA	H4TXV02
4HP14L42P-7	BCS2M42C****P+TXV		14.0	12.0	42,000	30,700	8.2	42,000	3.5	28,800	2.40	1,400	7/8	3/8	7/8	3/8	7/8	3/8	NA	H4TXV02
	BCS2M42V****P+TXV		15.0	12.5	42,000	30,700	8.5	42,000	3.6	28,000	2.30	1,400	7/8	3/8	7/8	3/8	7/8	3/8	NA	H4TXV02
	BCS3M42C****P+TXV		14.0	12.0	41,000	30,000	8.2	40,000	3.5	28,800	2.40	1,400	7/8	3/8	7/8	3/8	7/8	3/8	NA	H4TXV02
	BCS3M42E****P+H4TXV02		15.0	12.5	41,000	30,000	8.5	40,000	3.5	28,800	2.4	1,400	7/8	3/8	7/8	3/8	7/8	3/8	NA	H4TXV02
	E*1P49C+H4TXV02	80G2UH110CV20*	15.0	12.5	42,000	30,700	8.5	42,000	3.6	27,200	2.30	1,400	7/8	3/8	7/8	3/8	7/8	3/8	NA	H4TXV02
	E*1P49C+H4TXV02	EFV16CC	14.5	12.5	42,000	30,700	8.5	42,000	3.6	27,200	2.30	1,400	7/8	3/8	7/8	3/8	7/8	3/8	NA	H4TXV02
	E*1P49C+H4TXV02	80G1DF110CE20	15.0	12.5	42,000	30,700	8.5	42,000	3.6	27,200	2.30	1,400	7/8	3/8	7/8	3/8	7/8	3/8	NA	H4TXV02
	E*1P49C+H4TXV02	95G2UH090CV20	15.0	12.5	42,000	30,700	8.5	42,000	3.6	27,200	2.30	1,400	7/8	3/8	7/8	3/8	7/8	3/8	NA	H4TXV02
	E*1P49C+H4TXV02	80G1UH090CE20	15.0	12.5	42,000	30,700	8.5	42,000	3.6	27,200	2.30	1,400	7/8	3/8	7/8	3/8	7/8	3/8	NA	H4TXV02
	E*1P49C+H4TXV02	95G2UH110CV20	15.0	12.5	42,000	30,700	8.5	42,000	3.6	27,200	2.30	1,400	7/8	3/8	7/8	3/8	7/8	3/8	NA	H4TXV02
	E*1P49C+H4TXV02	95G1UH110CE20	15.0	12.5	42,000	30,700	8.5	42,000	3.6	27,200	2.30	1,400	7/8	3/8	7/8	3/8	7/8	3/8	NA	H4TXV02
	E*1P49C+H4TXV02	95G1UH090CE16	14.5	12.5	42,000	30,700	8.2	42,000	3.6	27,200	2.30	1,400	7/8	3/8	7/8	3/8	7/8	3/8	NA	H4TXV02
	E*1P49C+H4TXV02	95G2DF110CV20	14.5	12.5	42,000	30,700	8.2	42,000	3.6	27,200	2.30	1,400	7/8	3/8	7/8	3/8	7/8	3/8	NA	H4TXV02
	E*1P49C+H4TXV02	95G1DF110CE20	15.0	12.5	42,000	30,700	8.5	42,000	3.6	27,200	2.30	1,400	7/8	3/8	7/8	3/8	7/8	3/8	NA	H4TXV02
	E*1P49C+H4TXV02	95G2DF090CV20	14.5	12.5	42,000	30,700	8.2	42,000	3.6	27,200	2.30	1,400	7/8	3/8	7/8	3/8	7/8	3/8	NA	H4TXV02
	E*1P49C+H4TXV02	80G1UH110CE20	15.0	12.5	42,000	30,700	8.5	42,000	3.6	27,200	2.30	1,400	7/8	3/8	7/8	3/8	7/8	3/8	NA	H4TXV02
	E*1P62D+H4TXV02	EFV20DC	15.0	12.5	42,000	30,700	8.2	42,000	3.6	28,000	2.30	1,400	7/8	3/8	7/8	3/8	7/8	3/8	NA	H4TXV02
	E*1P62D+H4TXV02	95G2UH135DV20	15.0	12.5	42,000	30,700	8.5	42,000	3.6	28,000	2.30	1,400	7/8	3/8	7/8	3/8	7/8	3/8	NA	H4TXV02
	E*1P62D+H4TXV02	95G1UH135DE20	15.0	12.5	42,000	30,700	8.5	42,000	3.6	28,000	2.30	1,400	7/8	3/8	7/8	3/8	7/8	3/8	NA	H4TXV02
	E*1P62D+H4TXV02	80G1UH135DE20	15.0	12.5	42,000	30,700	8.2	42,000	3.6	28,000	2.30	1,400	7/8	3/8	7/8	3/8	7/8	3/8	NA	H4TXV02

Note:
 1 Certified in accordance with Unitary Air Conditioner Certification Program, which is based on AHRI Standard 210/240
 2 Required to achieve AHRI rating. If NA (Not Applicable) is in the piston column, then TXV is required.
 3 A blower time delay relay is required to achieve AHRI rating. This feature is standard on all Allied Air Enterprises furnace and AH products

Cooling Performance with Air Handlers and Furnaces 4 Ton, 5 Ton

Outdoor Model	Outdoor Model	Indoor Model		Cooling				Heating				CFM	Refrigerant Connection				Refrig. Line Size		Indoor Expansion Device			
		Evaporator Coil or Air Handler ³	Furnace	SEER	EER	ARI Rated Capacity ¹ Btuh	Rated Sensible Capacity Btuh	HSPF	47		17		Outdoor		Indoor		Suction	Liquid	Piston ²	TXV		
									Btuh	COP	Btuh		COP	Suction	Liquid	Suction					Liquid	
4HP14L48P-7	BCS2M48C****P+TXV			14.0	12.0	48,000	34,600	8.2	46,500	3.4	29,600	2.50	1,600	7/8	3/8	7/8	3/8	7/8	3/8	NA	H4TXV02	
	BCS2M48V****P+TXV			15.0	12.5	48,000	34,600	8.5	45,500	3.3	29,600	2.50	1,600	7/8	3/8	7/8	3/8	7/8	3/8	NA	H4TXV02	
	BCS3M48C****P+TXV			14.0	12.0	48,000	34,600	8.2	46,000	3.4	29,600	2.50	1,600	7/8	3/8	7/8	3/8	7/8	3/8	NA	H4TXV02	
	BCS3M48E****P+H4TXV02			15.0	12.5	48,000	34,600	8.5	46,000	3.4	29,600	2.5	1,600	7/8	3/8	7/8	3/8	7/8	3/8	NA	H4TXV02	
	E*1P49C+H4TXV02	80G2UH110CV20*			14.5	12.5	48,000	34,600	8.2	46,000	3.5	29,600	2.50	1,600	7/8	3/8	7/8	3/8	7/8	3/8	NA	H4TXV02
	E*1P49C+H4TXV02	EFV16CC			14.0	12.0	48,000	34,600	8.2	46,500	3.5	29,600	2.50	1,600	7/8	3/8	7/8	3/8	7/8	3/8	NA	H4TXV02
	E*1P49C+H4TXV02	95G2DF110CV20			14.0	12.0	48,000	34,600	8.2	46,500	3.5	29,600	2.50	1,600	7/8	3/8	7/8	3/8	7/8	3/8	NA	H4TXV02
	E*1P49C+H4TXV02	95G2UH090CV20			14.0	12.0	48,000	34,600	8.2	46,500	3.5	29,600	2.50	1,600	7/8	3/8	7/8	3/8	7/8	3/8	NA	H4TXV02
	E*1P49C+H4TXV02	80G1DF110CE20			14.5	12.5	48,000	34,600	8.2	46,000	3.5	29,600	2.50	1,600	7/8	3/8	7/8	3/8	7/8	3/8	NA	H4TXV02
	E*1P49C+H4TXV02	95G2DF090CV20			14.0	12.0	48,000	34,600	8.2	46,500	3.5	29,600	2.50	1,600	7/8	3/8	7/8	3/8	7/8	3/8	NA	H4TXV02
	E*1P49C+H4TXV02	95G1DF110CE20			14.5	12.5	48,000	34,600	8.2	46,000	3.5	29,600	2.50	1,600	7/8	3/8	7/8	3/8	7/8	3/8	NA	H4TXV02
	E*1P49C+H4TXV02	95G2UH110CV20			14.0	12.0	48,000	34,600	8.2	46,500	3.5	29,600	2.50	1,600	7/8	3/8	7/8	3/8	7/8	3/8	NA	H4TXV02
	E*1P62D+H4TXV02	EFV20DC			14.0	12.0	48,000	34,600	8.2	46,500	3.5	29,600	2.50	1,600	7/8	3/8	7/8	3/8	7/8	3/8	NA	H4TXV02
	E*1P62D+H4TXV02	95G2UH135DV20			14.5	12.5	48,000	34,600	8.2	46,000	3.5	29,600	2.50	1,600	7/8	3/8	7/8	3/8	7/8	3/8	NA	H4TXV02
E*1P62D+H4TXV02	95G1UH135DE20			14.0	12.0	48,000	34,600	8.2	46,000	3.5	29,600	2.50	1,600	7/8	3/8	7/8	3/8	7/8	3/8	NA	H4TXV02	
E*1P62D+H4TXV02	80G1UH135DE20			14.5	12.5	48,000	34,600	8.2	46,000	3.5	29,600	2.50	1,600	7/8	3/8	7/8	3/8	7/8	3/8	NA	H4TXV02	
4HP14L60P-7	BCS2M60C****P+TXV			14.0	12.0	58,000	42,300	8.2	55,000	3.4	36,000	2.50	1,800	7/8	3/8	7/8	3/8	1 1/8	3/8	NA	H4TXV03	
	BCS2M60V****P+TXV			15.0	12.5	58,000	42,300	8.5	55,000	3.5	36,000	2.50	1,800	7/8	3/8	7/8	3/8	1 1/8	3/8	NA	H4TXV03	
	BCS3M60C****P+TXV			14.0	12.0	57,000	41,600	8.2	55,000	3.4	36,000	2.50	1,900	7/8	3/8	7/8	3/8	1 1/8	3/8	NA	H4TXV03	
	BCS3M60E****P+H4TXV03			15.0	12.5	57,000	41,600	8.5	55,000	3.4	36,000	2.5	1,900	7/8	3/8	7/8	3/8	1 1/8	3/8	NA	H4TXV03	

Note:
 1 Certified in accordance with Unitary Air Conditioner Certification Program, which is based on AHRI Standard 210/240
 2 Required to achieve AHRI rating. If NA (Not Applicable) is in the piston column, then TXV is required.
 3 A blower time delay relay is required to achieve AHRI rating. This feature is standard on all Allied Air Enterprises furnace and AH products

Cooling Performance with Extended Ratings

Outdoor Model	Indoor Model	Indoor Temp DB/WB °F	Outdoor Temp - DB°F														
			65			82			95			105			115		
			Btuh	S/T	kW	Btuh	S/T	kW	Btuh	S/T	kW	Btuh	S/T	kW	Btuh	S/T	kW
4HP14L18P-7	BCS*M18	85/72	21,000	0.61	1.14	20,000	0.65	1.34	19,300	0.68	1.50	17,900	0.72	1.67	16,400	0.75	1.84
		80/67	19,800	0.69	1.13	18,800	0.72	1.34	18,000	0.75	1.50	16,300	0.80	1.67	14,700	0.85	1.84
		75/63	18,900	0.72	1.13	17,200	0.77	1.34	15,900	0.81	1.50	14,400	0.87	1.67	12,800	0.92	1.84
		75/57	17,200	1.00	1.11	16,700	1.00	1.31	16,000	1.00	1.47	14,500	1.00	1.64	13,100	1.00	1.80
4HP14L24P-7	BCS*M24	85/72	30,200	0.61	1.48	27,700	0.64	1.75	25,700	0.66	1.95	24,200	0.68	2.20	22,700	0.69	2.44
		80/67	27,600	0.69	1.47	25,200	0.71	1.74	23,400	0.73	1.95	22,100	0.75	2.19	20,700	0.77	2.42
		75/63	25,100	0.72	1.47	23,300	0.74	1.74	21,800	0.76	1.95	20,500	0.78	2.19	19,100	0.80	2.43
		75/57	24,000	1.00	1.44	22,400	1.00	1.71	20,800	1.00	1.91	19,700	1.00	2.15	18,400	1.00	2.37
4HP14L30P-7	BCS*M30	85/72	35,800	0.62	1.88	33,600	0.64	2.19	31,900	0.66	2.43	30,200	0.68	2.72	28,400	0.70	3.00
		80/67	33,500	0.69	1.86	31,000	0.72	2.18	29,000	0.74	2.42	27,600	0.76	2.70	26,200	0.78	2.99
		75/63	31,300	0.72	1.84	29,000	0.75	2.17	27,300	0.77	2.42	25,700	0.79	2.70	24,100	0.81	2.98
		75/57	29,100	1.00	1.82	27,600	1.00	2.14	25,800	1.00	2.37	24,600	1.00	2.65	23,300	1.00	2.93
4HP14L36P-7	BCS*M36	85/72	39,700	0.61	2.21	38,100	0.64	2.59	36,900	0.67	2.89	34,600	0.70	3.21	32,400	0.73	3.54
		80/67	37,800	0.69	2.20	36,000	0.72	2.59	34,600	0.75	2.88	31,900	0.79	3.21	29,300	0.83	3.53
		75/63	36,100	0.73	2.20	33,300	0.77	2.58	31,100	0.80	2.87	29,000	0.83	3.19	26,800	0.85	3.51
		75/57	32,900	1.00	2.16	32,000	1.00	2.54	30,800	1.00	2.82	28,400	1.00	3.15	26,100	1.00	3.46
4HP14L42P-7	BCS*M42	85/72	50,600	0.60	2.66	47,800	0.63	3.14	45,700	0.65	3.51	42,800	0.67	3.92	39,900	0.69	4.33
		80/67	48,200	0.68	2.66	44,700	0.71	3.13	42,000	0.73	3.50	39,500	0.75	3.91	37,000	0.77	4.33
		75/63	44,200	0.72	2.64	41,300	0.74	3.12	39,200	0.75	3.49	36,600	0.77	3.89	34,000	0.79	4.30
		75/57	41,900	1.00	2.61	39,800	1.00	3.07	37,400	1.00	3.43	35,200	1.00	3.83	32,900	1.00	4.24
4HP14L48P-7	BCS*M48	85/72	51,900	0.62	2.95	51,400	0.64	3.55	51,000	0.65	4.00	48,400	0.68	4.47	45,800	0.70	4.93
		80/67	49,800	0.68	2.95	48,800	0.70	3.55	48,000	0.72	4.00	45,500	0.75	4.45	42,900	0.77	4.90
		75/63	47,900	0.71	2.95	45,600	0.74	3.53	43,800	0.77	3.98	40,800	0.82	4.43	37,900	0.86	4.88
		75/57	43,300	1.00	2.89	43,400	1.00	3.48	42,700	1.00	3.92	40,500	1.00	4.36	38,200	1.00	4.80
4HP14L60P-7	BCS*M60	85/72	72,000	0.62	3.68	66,300	0.65	4.34	62,000	0.67	4.85	58,000	0.69	5.47	54,000	0.71	6.09
		80/67	65,800	0.68	3.64	61,400	0.71	4.32	58,000	0.73	4.83	54,000	0.77	5.45	50,000	0.80	6.07
		75/63	60,800	0.71	3.60	56,200	0.74	4.29	52,700	0.76	4.81	49,400	0.78	5.43	46,100	0.80	6.04
		75/57	57,200	1.00	3.57	54,600	1.00	4.23	51,600	1.00	4.73	48,100	1.00	5.34	44,500	1.00	5.95

Note: Extended data shown is actual for models listed and typical for all AHRI matches.

Heating Performance with Extended Ratings

Outdoor Model	Indoor Model	Outdoor Temp - DB/WB°F°									
		00		17/15		35/33		47/43		62/56	
		Btuh	kW	Btuh	kW	Btuh	kW	Btuh	kW	Btuh	kW
4HP14L18P-7	BCS*M18	4,300	1.26	10,500	1.36	14,800	1.47	17,400	1.50	21,400	1.54
4HP14L24P-7	BCS*M24	5,800	1.54	14,000	1.78	18,700	1.83	22,000	1.90	26,900	2.00
4HP14L30P-7	BCS*M30	7,800	1.76	17,000	1.99	22,600	2.19	26,200	2.26	31,600	2.36
4HP14L36P-7	BCS*M36	9,700	2.20	21,600	2.53	29,700	2.80	34,600	2.90	41,900	3.04
4HP14L42P-7	BCS*M42	12,700	3.14	28,800	3.52	36,000	3.42	42,000	3.52	51,000	3.66
4HP14L48P-7	BCS*M48	14,100	2.85	29,600	3.47	40,300	3.83	46,500	4.01	55,800	4.28
4HP14L60P-7	BCS*M60	18,000	3.37	36,000	4.22	48,000	4.78	55,000	5.04	65,500	5.43

Note: Extended data shown is actual for models listed and typical for all AHRI matches.

Accessories

Description	Where Used	Kit Number
Crankcase Heater	18, 24, 30, 36	93M04
	42, 48, 60	93M05
Hard Start Kit	18	10J42
	24, 30, 36, 42, 48, 60	88M91
Compressor Low Ambient Kit	18, 24, 30, 36, 42, 48, 60	45F08
Sound Blanket	18, 24, 30, 36, 42, 48, 60	69J03
Short Cycle Protector	18, 24, 30, 36, 42, 48, 60 (Factory Installed)	47J27
Freezestat	3/8 tubing	93G35
	5/8 tubing	50A93
Time Delay Relay	18, 24, 30, 36, 42, 48, 60	58M81
Loss of Charge Kit	18, 24, 30, 36, 42, 48, 60	84M23



1-800-448-5872

All specifications and illustrations subject to change without notice and without incurring obligations.