

4HP13

PRODUCT SPECIFICATIONS

13 SEER SPLIT SYSTEM HEAT PUMP

FORM NO. 4HP13-100 (05/2014)



- R410A Refrigerant
- High-quality condenser coil with copper tubing and enhanced louvered fin for maximum heat transfer capacity
- Top discharge directs hot air and sound away from living area and shrubbery
- All units run tested
- Available with louvered panel or wire guard coil protection option
- Easy access to electrical panels, pre-wired for easy hook-up
- Bi-directional liquid line filter drier factory installed
- Discharge muffler for quiet operation
- Reliable, solid state time/temperature defrost control, with field selectable 30/60/90 minute intervals
- Defrost control is Quiet Shift™ capable
- Low pressure switch factory installed for loss of charge protection
- Integrated control with LED diagnostics
- Short cycle protection factory installed
- Charged for 15 feet of interconnecting tubing
- All units are ETL and ETLIC approved and AHRI certified

WARRANTY

10-Year limited warranty on compressor, 10-Year limited warranty on all parts, extended warranty available*

**Warranty provides for a total of 10 years of limited warranty coverage (Standard 5-year limited parts warranty plus an additional 5-year limited extended parts warranty). Warranty must be registered online within 60 days of installation to qualify for 10-year coverage. Unregistered equipment defaults to 5-year coverage. Lifetime limited heat exchanger warranty applies to registered equipment only (Standard 20 years with no online registration). See full warranty at www.alliedair.com for terms, conditions and exclusions.*



Model Number Guide

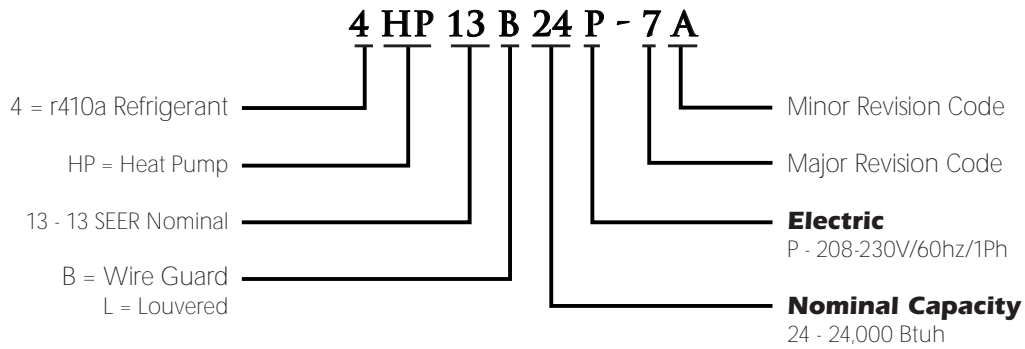

Physical and Electrical Data

Model	Volts/Hz/Phase	Voltage Range	Min. Circuit Amp.	Max. Over-current Device (amps)	Compressor		Fan Motor			Refrig. Charge (oz.)	Weight (lbs.)	
					Rated Load (amps)	Locked Rotor (amps)	Rated Load (amps)	Rated HP	Nom. RPM		Wire Guard	Louvered
4HP13*18P-7	208-230/60/1	197-253	11.9	20	9.0	48	0.7	1/10	1075	106	142	153
4HP13*24P-7	208-230/60/1	197-253	14.2	20	10.7	53	0.8	1/10	1075	101	147	158
4HP13*30P-7	208-230/60/1	197-253	16.3	25	12.4	59	0.7	1/6	825	108	156	168
4HP13*36P-7	208-230/60/1	197-253	19.9	35	15.2	70	0.9	1/6	825	114	172	187
4HP13*42P-7	208-230/60/1	197-253	27.8	45	21.1	90	1.4	1/4	825	134	207	224
4HP13*48P-7	208-230/60/1	197-253	31.7	50	24.1	100	1.5	1/4	825	198	223	236
4HP13*60P-7	208-230/60/1	197-253	36.3	60	27.6	120	1.7	1/3	825	210	227	252

* = B or L
 B = Wire Guard
 L = Louvered

Note: Weights listed are unit weights with packaging
 + Factory charged for 15 feet of line set. Adjust per installation instructions.

Unit Dimensions & Sound Ratings

Model	Dimensions			Sound Ratings (dBA)
	A-Width (in.)	B-Depth (in.)	C-Height (in.)	
4HP13*18P-7	24.25	24.25	33.00	76
4HP13*24P-7	24.25	24.25	33.00	76
4HP13*30P-7	28.25	28.25	29.00	76
4HP13*36P-7	28.25	28.25	37.00	76
4HP13*42P-7	28.25	28.25	43.00	80
4HP13*48P-7	28.25	28.25	33.00	80
4HP13*60P-7	28.25	28.25	37.00	80

* = B or L B = Wire Guard L = Louvered

Note: Dimensions listed are unit sizes without packaging.

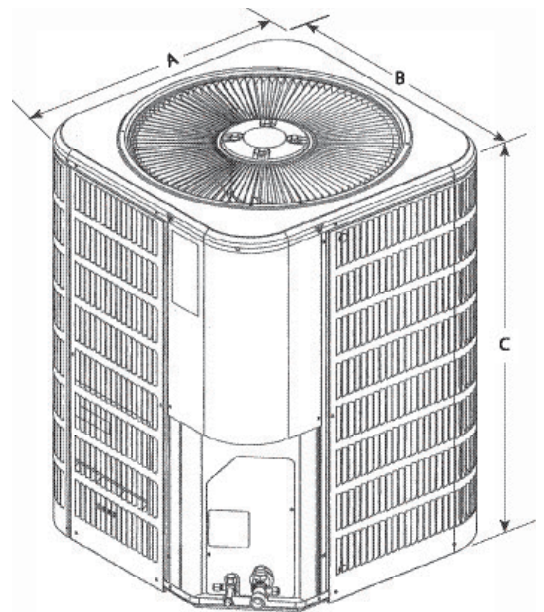

Cooling Performance with Evaporator Coils

Outdoor Model	Indoor Model	Cooling				Heating				CFM	Refrigerant Connection				Refrig. Line Size		Indoor Expansion Device		
		SEER	EER	ARI Rated Capacity ¹ BTUH	Sensible Capacity BTUH	HSPF	47		17		Outdoor		Indoor		Suction	Liquid	Piston ²	TXV	
							Btuh	COP	Btuh		COP	Suction	Liquid	Suction					Liquid
4HP13*18P-7	E(C,H,M,U)1P18(A,B)	13.00	11.00	18,000	12780	7.70	17000	3.20	10000	2.00	650	3/4	3/8	3/4	3/8	3/4	3/8	NA	H4TXV01
	E(C,H,M,U)1P24(A,B)	13.00	11.00	18,000	12780	7.70	17000	3.20	10000	2.00	650	3/4	3/8	3/4	3/8	3/4	3/8	NA	H4TXV01
4HP13*24P-7	E(C,H,M,U)1P23(A,B)	13.00	11.00	23,000	16790	7.70	21600	3.30	13000	2.20	850	3/4	3/8	3/4	3/8	3/4	3/8	57	H4TXV01
	E(C,H,M,U)1P24(A,B)	13.00	11.00	23,000	16790	7.70	21600	3.30	13000	2.20	850	3/4	3/8	3/4	3/8	3/4	3/8	57	H4TXV01
4HP13*30P-7	E(C,H,M,U)1P29(A,B)	13.00	11.00	29,000	21460	7.70	27000	3.40	17000	2.20	1000	3/4	3/8	3/4	3/8	3/4	3/8	62	H4TXV01
	E(C,H,M,U)1P30(B,C)	13.00	11.00	29,000	21460	7.70	27000	3.40	17000	2.20	1000	3/4	3/8	3/4	3/8	3/4	3/8	62	H4TXV01
4HP13*36P-7	E(C,H,M,U)1P30(B,C)	13.00	11.00	35,000	25200	7.70	33800	3.40	18000	2.20	1275	3/4	3/8	3/4	3/8	3/4	3/8	71	H4TXV01
	E(C,H,M,U)1P36(B,C)	13.00	11.00	35,000	25200	7.70	33800	3.40	18000	2.20	1275	3/4	3/8	3/4	3/8	3/4	3/8	71	H4TXV01
4HP13*42P-7	E(C,H,M,U)1P36(B,C)	13.00	11.00	41,000	29520	7.70	40000	3.50	25000	2.20	1400	7/8	3/8	7/8	3/8	7/8	3/8	76	H4TXV02
	E(C,H,M,U)1P43(B,C)	13.00	11.00	41,000	29520	7.70	40000	3.50	25000	2.20	1400	7/8	3/8	7/8	3/8	7/8	3/8	76	H4TXV02
4HP13*48P-7	E(C,H,M,U)1P50(B,C)	13.00	11.00	48,000	34560	7.70	45000	3.20	28000	2.40	1600	7/8	3/8	7/8	3/8	7/8	3/8	80	H4TXV02
4HP13*60P-7	E(C,H,M,U)1P49(B,C)	13.00	11.00	58,000	41180	7.70	55000	3.30	34000	2.30	1850	7/8	3/8	7/8	3/8	1-1/8	3/8	NA	H4TXV02
	E(C,H,M,U)1P62C	13.00	11.00	58,000	41180	7.70	55000	3.30	34000	2.30	1850	7/8	3/8	7/8	3/8	1-1/8	3/8	NA	H4TXV02
	E(C,H,M,U)1P62D	13.00	11.00	58,000	41180	7.70	55000	3.30	34000	2.30	1850	7/8	3/8	7/8	3/8	1-1/8	3/8	NA	H4TXV02

Note:
 Certified in accordance with Unitary Air Conditioner Certification Program, which is based on AHRI Standard 210/240. Required to achieve AHRI rating. If NA (Not Applicable) is in the piston column, then TXV is required.
 A blower time delay relay is standard on all Allied Air Enterprises furnaces and AH products.

* = B or L
 B - Wire Guard
 L - Louvered

Cooling Performance with Air Handlers and Furnaces 18

Outdoor Model	Indoor Model		Cooling					Heating				CFM	Refrigerant Connection				Refrig. Line Size		Indoor Expansion Device	
	Evaporator Coil or Air Handler ³	Furnaces	SEER	EER	ARI Rated Capacity ¹	Sensible Capacity	HSPF	47		17			Outdoor		Indoor		Suction	Liquid	Piston ²	TXV
								Btuh	COP	Btuh	COP		Suction	Liquid	Suction	Liquid				
4HP13*18P-7	BCS2M24V****P		14.0	11.0	18,000	12,780	7.7	17,000	3.2	10,000	2.00	650	3/4	3/8	3/4	3/8	3/4	3/8	NA	H4TXV01
	BCS3M18C****P		13.0	11.0	17,600	12,500	7.7	16,600	3.2	10,000	2.00	650	3/4	3/8	3/4	3/8	3/4	3/8	NA	H4TXV01
	BCS3M24E****P		14.0	11.0	17,600	12,500	7.7	16,600	3.2	10,000	2.00	650	3/4	3/8	3/4	3/8	3/4	3/8	NA	H4TXV01
	E(C,H,M,U)1P18A	80G1DF045AE12	13.5	11.0	18,000	12,780	7.7	17,000	3.2	10,000	2.00	650	3/4	3/8	3/4	3/8	3/4	3/8	NA	H4TXV01
	E(C,H,M,U)1P24A	80G1DF045AE12	13.5	11.0	18,000	12,780	7.7	17,000	3.2	10,000	2.00	650	3/4	3/8	3/4	3/8	3/4	3/8	NA	H4TXV01
	E(C,H,M,U)1P18B	80G1DF070BE12	13.5	11.0	18,000	12,780	7.7	17,000	3.2	10,000	2.00	650	3/4	3/8	3/4	3/8	3/4	3/8	NA	H4TXV01
	E(C,H,M,U)1P24B	80G1DF070BE12	13.5	11.0	18,000	12,780	7.7	17,000	3.2	10,000	2.00	650	3/4	3/8	3/4	3/8	3/4	3/8	NA	H4TXV01
	E(C,H,M,U)1P18A	80G1UH045AE12	13.5	11.0	18,000	12,780	7.7	17,000	3.2	10,000	2.00	650	3/4	3/8	3/4	3/8	3/4	3/8	NA	H4TXV01
	E(C,H,M,U)1P24A	80G1UH045AE12	13.5	11.0	18,000	12,780	7.7	17,000	3.2	10,000	2.00	650	3/4	3/8	3/4	3/8	3/4	3/8	NA	H4TXV01
	E(C,H,M,U)1P18B	80G1UH070BE12	13.5	11.0	18,000	12,780	7.7	17,000	3.2	10,000	2.00	650	3/4	3/8	3/4	3/8	3/4	3/8	NA	H4TXV01
	E(C,H,M,U)1P24B	80G1UH070BE12	13.5	11.0	18,000	12,780	7.7	17,000	3.2	10,000	2.00	650	3/4	3/8	3/4	3/8	3/4	3/8	NA	H4TXV01
	E(C,H,M,U)1P18A	80G2UH070AV12*	14.0	11.0	18,000	12,780	7.7	17,000	3.2	10,000	2.00	650	3/4	3/8	3/4	3/8	3/4	3/8	NA	H4TXV01
	E(C,H,M,U)1P24A	80G2UH070AV12*	14.0	11.0	18,000	12,780	7.7	17,000	3.2	10,000	2.00	650	3/4	3/8	3/4	3/8	3/4	3/8	NA	H4TXV01
	E(C,H,M,U)1P18B	80G2UH090BV16*	14.0	11.0	18,000	12,780	7.7	17,000	3.2	10,000	2.00	650	3/4	3/8	3/4	3/8	3/4	3/8	NA	H4TXV01
	E(C,H,M,U)1P24B	80G2UH090BV16*	14.0	11.0	18,000	12,780	7.7	17,000	3.2	10,000	2.00	650	3/4	3/8	3/4	3/8	3/4	3/8	NA	H4TXV01
	E(C,H,M,U)1P18B	95G1DF045BE12	13.5	11.0	18,000	12,780	7.7	17,000	3.2	10,000	2.00	650	3/4	3/8	3/4	3/8	3/4	3/8	NA	H4TXV01
	E(C,H,M,U)1P24B	95G1DF045BE12	13.5	11.0	18,000	12,780	7.7	17,000	3.2	10,000	2.00	650	3/4	3/8	3/4	3/8	3/4	3/8	NA	H4TXV01
	E(C,H,M,U)1P18B	95G1UH045BE12	13.5	11.0	18,000	12,780	7.7	17,000	3.2	10,000	2.00	650	3/4	3/8	3/4	3/8	3/4	3/8	NA	H4TXV01
	E(C,H,M,U)1P24B	95G1UH045BE12	13.5	11.0	18,000	12,780	7.7	17,000	3.2	10,000	2.00	650	3/4	3/8	3/4	3/8	3/4	3/8	NA	H4TXV01
	E(C,H,M,U)1P18B	95G1UH070BE12	13.5	11.0	18,000	12,780	7.7	17,000	3.2	10,000	2.00	650	3/4	3/8	3/4	3/8	3/4	3/8	NA	H4TXV01
	E(C,H,M,U)1P24B	95G1UH070BE12	13.5	11.0	18,000	12,780	7.7	17,000	3.2	10,000	2.00	650	3/4	3/8	3/4	3/8	3/4	3/8	NA	H4TXV01
	E(C,H,M,U)1P18B	95G2DF045BV12	13.5	11.0	18,000	12,780	7.7	17,000	3.2	10,000	2.00	650	3/4	3/8	3/4	3/8	3/4	3/8	NA	H4TXV01
	E(C,H,M,U)1P24B	95G2DF045BV12	13.5	11.0	18,000	12,780	7.7	17,000	3.2	10,000	2.00	650	3/4	3/8	3/4	3/8	3/4	3/8	NA	H4TXV01
	E(C,H,M,U)1P18B	95G2DF070BV16	14.0	11.0	18,000	12,780	7.7	17,000	3.2	10,000	2.00	650	3/4	3/8	3/4	3/8	3/4	3/8	NA	H4TXV01
	E(C,H,M,U)1P24B	95G2DF070BV16	14.0	11.0	18,000	12,780	7.7	17,000	3.2	10,000	2.00	650	3/4	3/8	3/4	3/8	3/4	3/8	NA	H4TXV01
	E(C,H,M,U)1P24B	95G2UH045BV12	14.0	11.0	18,000	12,780	7.7	17,000	3.2	10,000	2.00	650	3/4	3/8	3/4	3/8	3/4	3/8	NA	H4TXV01
E(C,H,M,U)1P18B	95G2UH070BV12	14.0	11.0	18,000	12,780	7.7	17,000	3.2	10,000	2.00	650	3/4	3/8	3/4	3/8	3/4	3/8	NA	H4TXV01	
E(C,H,M,U)1P24B	95G2UH070BV12	14.0	11.0	18,000	12,780	7.7	17,000	3.2	10,000	2.00	650	3/4	3/8	3/4	3/8	3/4	3/8	NA	H4TXV01	

Note:

1. Certified in accordance with Unitary Air Conditioner Certification Program, which is based on AHRI Standard 210/240
2. Required to achieve AHRI rating. If NA (Not Applicable) is in the piston column, then TXV is required.
3. A blower time delay relay is standard on all Allied Air Enterprises furnaces and AH products.

* = B or L

B = Wire Guard

L = Louvered

Cooling Performance with Air Handlers and Furnaces 18, 24

Outdoor Model	Indoor Model		Cooling				Heating				CFM	Refrigerant Connection				Refrig. Line Size		Indoor Expansion Device		
	Evaporator Coil or Air Handler ³	Furnaces	SEER	EER	ARI Rated Capacity ¹	Sensible Capacity	HSPF	47		17		Outdoor		Indoor		Suction	Liquid	Piston ²	TXV	
								Btuh	COP	Btuh		COP	Suction	Liquid	Suction					Liquid
4HP13*18P-7	E(C,H,M,U)1P18B	95G2UH045BV12	14.0	11.0	18,000	12,780	7.7	17,000	3.2	10,000	2.00	650	3/4	3/8	3/4	3/8	3/4	3/8	NA	H4TXV01
	E(C,H,M,U)1P24B	95G2UH045BV12	14.0	11.0	18,000	12,780	7.7	17,000	3.2	10,000	2.00	650	3/4	3/8	3/4	3/8	3/4	3/8	NA	H4TXV01
	E(C,H,M,U)1P18B	95G2UH070BV12	14.0	11.0	18,000	12,780	7.7	17,000	3.2	10,000	2.00	650	3/4	3/8	3/4	3/8	3/4	3/8	NA	H4TXV01
	E(C,H,M,U)1P24B	95G2UH070BV12	14.0	11.0	18,000	12,780	7.7	17,000	3.2	10,000	2.00	650	3/4	3/8	3/4	3/8	3/4	3/8	NA	H4TXV01
4HP13*24P-7	BCS3M24C****P		13.0	11.0	23,000	16,790	7.7	21,400	3.3	13,000	2.20	850	3/4	3/8	7/8	3/8	3/4	3/8	.057	H4TXV01
	BCS2M24V****P		14.0	11.0	23,000	16,790	7.7	21,600	3.3	13,000	2.20	850	3/4	3/8	3/4	3/8	3/4	3/8	0.057	H4TXV01
	BCS3M30E****P		14.0	11.0	23,000	16,790	7.7	21,400	3.3	13,000	2.20	850	3/4	3/8	7/8	3/8	3/4	3/8	0.057	H4TXV01
	E(C,H,M,U)1P23A	80G1DF045AE12	14.0	11.0	23,000	16,790	7.7	21,600	3.3	13,000	2.20	850	3/4	3/8	3/4	3/8	3/4	3/8	.057	H4TXV01
	E(C,H,M,U)1P24A	80G1DF045AE12	14.0	11.0	23,000	16,790	7.7	21,600	3.3	13,000	2.20	850	3/4	3/8	3/4	3/8	3/4	3/8	.057	H4TXV01
	E(C,H,M,U)1P23B	80G1DF070BE12	14.0	11.0	23,000	16,790	7.7	21,600	3.3	13,000	2.20	850	3/4	3/8	3/4	3/8	3/4	3/8	.057	H4TXV01
	E(C,H,M,U)1P24B	80G1DF070BE12	14.0	11.0	23,000	16,790	7.7	21,600	3.3	13,000	2.20	850	3/4	3/8	3/4	3/8	3/4	3/8	.057	H4TXV01
	E(C,H,M,U)1P23A	80G1UH045AE12	13.5	11.0	23,000	16,790	7.7	21,600	3.3	13,000	2.20	850	3/4	3/8	3/4	3/8	3/4	3/8	.057	H4TXV01
	E(C,H,M,U)1P24A	80G1UH045AE12	14.0	11.0	23,000	16,790	7.7	21,600	3.3	13,000	2.20	850	3/4	3/8	3/4	3/8	3/4	3/8	.057	H4TXV01
	E(C,H,M,U)1P23B	80G1UH070BE12	14.0	11.0	23,000	16,790	7.7	21,600	3.3	13,000	2.20	850	3/4	3/8	3/4	3/8	3/4	3/8	.057	H4TXV01
	E(C,H,M,U)1P24B	80G1UH070BE12	14.0	11.0	23,000	16,790	7.7	21,600	3.3	13,000	2.20	850	3/4	3/8	3/4	3/8	3/4	3/8	.057	H4TXV01
	E(C,H,M,U)1P23A	80G2UH070AV12*	14.0	11.0	23,000	16,790	7.7	21,400	3.3	13,000	2.20	850	3/4	3/8	3/4	3/8	3/4	3/8	.057	H4TXV01
	E(C,H,M,U)1P24A	80G2UH070AV12*	14.0	11.0	23,000	16,790	7.7	21,600	3.3	13,000	2.20	850	3/4	3/8	3/4	3/8	3/4	3/8	.057	H4TXV01
	E(C,H,M,U)1P23B	80G2UH090BV16*	13.5	11.0	23,000	16,790	7.7	21,400	3.3	13,000	2.20	850	3/4	3/8	3/4	3/8	3/4	3/8	.057	H4TXV01
	E(C,H,M,U)1P24B	80G2UH090BV16*	13.5	11.0	23,000	16,790	7.7	21,600	3.3	13,000	2.20	850	3/4	3/8	3/4	3/8	3/4	3/8	.057	H4TXV01
	E(C,H,M,U)1P23B	95G1DF045BE12	13.5	11.0	23,000	16,790	7.7	21,600	3.3	13,000	2.20	850	3/4	3/8	3/4	3/8	3/4	3/8	.057	H4TXV01
	E(C,H,M,U)1P24B	95G1DF045BE12	14.0	11.0	23,000	16,790	7.7	21,600	3.3	13,000	2.20	850	3/4	3/8	3/4	3/8	3/4	3/8	.057	H4TXV01
	E(C,H,M,U)1P23B	95G1UH045BE12	13.5	11.0	23,000	16,790	7.7	21,600	3.3	13,000	2.20	850	3/4	3/8	3/4	3/8	3/4	3/8	.057	H4TXV01
	E(C,H,M,U)1P24B	95G1UH045BE12	14.0	11.0	23,000	16,790	7.7	21,600	3.3	13,000	2.20	850	3/4	3/8	3/4	3/8	3/4	3/8	.057	H4TXV01
	E(C,H,M,U)1P23B	95G1UH070BE12	13.5	11.0	23,000	16,790	7.7	21,600	3.3	13,000	2.20	850	3/4	3/8	3/4	3/8	3/4	3/8	.057	H4TXV01
	E(C,H,M,U)1P24B	95G1UH070BE12	14.0	11.0	23,000	16,790	7.7	21,600	3.3	13,000	2.20	850	3/4	3/8	3/4	3/8	3/4	3/8	.057	H4TXV01
	E(C,H,M,U)1P23B	95G2DF045BV12	14.0	11.0	23,000	16,790	7.7	21,600	3.3	13,000	2.20	850	3/4	3/8	3/4	3/8	3/4	3/8	.057	H4TXV01
	E(C,H,M,U)1P24B	95G2DF045BV12	14.0	11.0	23,000	16,790	7.7	21,600	3.3	13,000	2.20	850	3/4	3/8	3/4	3/8	3/4	3/8	.057	H4TXV01
	E(C,H,M,U)1P23B	95G2DF070BV16	14.0	11.0	23,000	16,790	7.7	21,600	3.3	13,000	2.20	850	3/4	3/8	3/4	3/8	3/4	3/8	.057	H4TXV01
	E(C,H,M,U)1P24B	95G2DF070BV16	14.0	11.0	23,000	16,790	7.7	21,600	3.3	13,000	2.20	850	3/4	3/8	3/4	3/8	3/4	3/8	.057	H4TXV01

Note:

1. Certified in accordance with Unitary Air Conditioner Certification Program, which is based on AHRI Standard 210/240
2. Required to achieve AHRI rating. If NA (Not Applicable) is in the piston column, then TXV is required.
3. A blower time delay relay is standard on all Allied Air Enterprises furnaces and AH products.

* = B or L

B = Wire Guard

L = Louvered

Cooling Performance with Air Handlers and Furnaces 24, 30

Outdoor Model	Indoor Model		Cooling				Heating				CFM	Refrigerant Connection				Refrig. Line Size		Indoor Expansion Device		
	Evaporator Coil or Air Handler ³	Furnaces	SEER	EER	ARI Rated Capacity ¹	Sensible Capacity	HSPF	47		17		Outdoor		Indoor		Suction	Liquid	Piston ²	TXV	
								Btuh	COP	Btuh		COP	Suction	Liquid	Suction					Liquid
4HP13*24P-7	E(C,H,M,U)1P23B	95G2UH045BV12	14.0	11.0	23,000	16,790	7.7	21,600	3.3	13,000	2.20	850	3/4	3/8	3/4	3/8	3/4	3/8	.057	H4TXV01
	E(C,H,M,U)1P24B	95G2UH045BV12	14.0	11.0	23,000	16,790	7.7	21,600	3.3	13,000	2.20	850	3/4	3/8	3/4	3/8	3/4	3/8	.057	H4TXV01
	E(C,H,M,U)1P23B	95G2UH070BV12	14.0	11.0	23,000	16,790	7.7	21,600	3.3	13,000	2.20	850	3/4	3/8	3/4	3/8	3/4	3/8	.057	H4TXV01
	E(C,H,M,U)1P24B	95G2UH070BV12	14.0	11.0	23,000	16,790	7.7	21,600	3.3	13,000	2.20	850	3/4	3/8	3/4	3/8	3/4	3/8	.057	H4TXV01
4HP13*30P-7	BCS2M36V****P		14.0	11.0	29,000	21,460	7.7	27,000	3.4	17,000	2.20	1,000	3/4	3/8	3/4	3/8	3/4	3/8	0.062	H4TXV01
	BCS3M30C****P		13.0	11.0	29,000	21,460	7.7	27,000	3.4	17,000	2.20	1,000	3/4	3/8	7/8	3/8	3/4	3/8	0.062	H4TXV01
	BCS3M30E****P		14.0	11.0	29,000	21,460	7.7	27,000	3.4	17,000	2.20	1,000	3/4	3/8	7/8	3/8	3/4	3/8	0.062	H4TXV01
	E(C,H,M,U)1P29A	80G1DF045AE12	13.5	11.0	29,000	21,460	7.7	27,000	3.4	17,000	2.20	1,000	3/4	3/8	3/4	3/8	3/4	3/8	.062	H4TXV01
	E(C,H,M,U)1P29B	80G1DF070BE12	14.0	11.0	29,000	21,460	7.7	26,800	3.4	16,800	2.20	1,000	3/4	3/8	3/4	3/8	3/4	3/8	.062	H4TXV01
	E(C,H,M,U)1P29B	80G1DF090BE16	14.0	11.0	29,000	21,460	7.7	26,800	3.4	16,800	2.20	1,000	3/4	3/8	3/4	3/8	3/4	3/8	.062	H4TXV01
	E(C,H,M,U)1P29A	80G1UH045AE12	14.0	11.0	29,000	21,460	7.7	27,000	3.4	17,000	2.20	1,000	3/4	3/8	3/4	3/8	3/4	3/8	.062	H4TXV01
	E(C,H,M,U)1P29B	80G1UH070BE12	14.0	11.0	29,000	21,460	7.7	26,800	3.4	16,800	2.20	1,000	3/4	3/8	3/4	3/8	3/4	3/8	.062	H4TXV01
	E(C,H,M,U)1P29B	80G1UH090BE16	14.0	11.0	29,000	21,460	7.7	26,800	3.4	16,800	2.20	1,000	3/4	3/8	3/4	3/8	3/4	3/8	.062	H4TXV01
	E(C,H,M,U)1P29A	80G2UH070AV12*	13.5	11.0	29,000	21,460	7.7	27,000	3.4	16,800	2.20	1,000	3/4	3/8	3/4	3/8	3/4	3/8	.062	H4TXV01
	E(C,H,M,U)1P29B	80G2UH090BV16*	13.5	11.0	29,000	21,460	7.7	27,000	3.4	17,000	2.20	1,000	3/4	3/8	3/4	3/8	3/4	3/8	.062	H4TXV01
	E(C,H,M,U)1P29B	95G1DF045BE12	13.5	11.0	29,000	21,460	7.7	27,000	3.4	17,000	2.20	1,000	3/4	3/8	3/4	3/8	3/4	3/8	.062	H4TXV01
	E(C,H,M,U)1P29B	95G1DF070BE16	14.0	11.0	29,000	21,460	7.7	27,000	3.4	17,000	2.20	1,000	3/4	3/8	3/4	3/8	3/4	3/8	.062	H4TXV01
	E(C,H,M,U)1P29B	95G1UH045BE12	13.5	11.0	29,000	21,460	7.7	27,000	3.4	17,000	2.20	1,000	3/4	3/8	3/4	3/8	3/4	3/8	.062	H4TXV01
	E(C,H,M,U)1P29B	95G1UH070BE12	13.5	11.0	29,000	21,460	7.7	27,000	3.4	17,000	2.20	1,000	3/4	3/8	3/4	3/8	3/4	3/8	.062	H4TXV01
	E(C,H,M,U)1P29B	95G2DF045BV12	14.0	11.0	29,000	21,460	7.7	27,000	3.4	16,800	2.20	1,000	3/4	3/8	3/4	3/8	3/4	3/8	.062	H4TXV01
	E(C,H,M,U)1P29B	95G2DF070BV16	13.5	11.0	29,000	21,460	7.7	27,000	3.4	17,000	2.20	1,000	3/4	3/8	3/4	3/8	3/4	3/8	.062	H4TXV01
	E(C,H,M,U)1P29B	95G2UH045BV12	13.5	11.0	29,000	21,460	7.7	27,000	3.4	17,000	2.20	1,000	3/4	3/8	3/4	3/8	3/4	3/8	.062	H4TXV01
	E(C,H,M,U)1P29B	95G2UH070BV12	14.0	11.0	29,000	21,460	7.7	27,000	3.4	16,800	2.20	1,000	3/4	3/8	3/4	3/8	3/4	3/8	.062	H4TXV01

Note:

1. Certified in accordance with Unitary Air Conditioner Certification Program, which is based on AHRI Standard 210/240
2. Required to achieve AHRI rating. If NA (Not Applicable) is in the piston column, then TXV is required.
3. A blower time delay relay is standard on all Allied Air Enterprises furnaces and AH products.

* = B or L

B = Wire Guard

L = Louvered

Cooling Performance with Air Handlers and Furnaces 36

Outdoor Model	Indoor Model		Cooling				Heating				CFM	Refrigerant Connection				Refrig. Line Size		Indoor Expansion Device		
	Evaporator Coil or Air Handler ³	Furnaces	SEER	EER	ARI Rated Capacity ¹	Sensible Capacity	HSPF	47		17		Outdoor		Indoor		Suction	Liquid	Piston ²	TXV	
								Btuh	COP	Btuh		COP	Suction	Liquid	Suction					Liquid
4HP13*36P-7	BCS2M36V****P		14.0	11.0	35,000	25,200	7.7	33,800	3.4	18,000	2.20	1,275	3/4	3/8	7/8	3/8	3/4	3/8	0.071	H4TXV02
	BCS3M36C****P		13.0	11.0	35,000	25,200	7.7	33,200	3.4	18,000	2.20	1,270	3/4	3/8	7/8	3/8	3/4	3/8	0.071	H4TXV02
	BCS3M36E****P		14.0	11.0	35,000	25,200	7.7	33,200	3.4	18,000	2.20	1,270	3/4	3/8	7/8	3/8	3/4	3/8	0.071	H4TXV02
	E(C,H,M,U)1P30A	80G1DF045AE12	13.5	11.0	35,000	25,200	7.7	32,800	3.4	18,000	2.20	1,275	3/4	3/8	3/4	3/8	3/4	3/8	.071	H4TXV02
	E(C,H,M,U)1P36A	80G1DF045AE12	14.0	11.0	35,000	25,200	7.7	33,000	3.4	18,000	2.20	1,275	3/4	3/8	3/4	3/8	3/4	3/8	.071	H4TXV02
	E(C,H,M,U)1P30B	80G1DF070BE12	13.5	11.0	35,000	25,200	7.7	32,800	3.4	18,000	2.20	1,275	3/4	3/8	3/4	3/8	3/4	3/8	.071	H4TXV02
	E(C,H,M,U)1P36B	80G1DF070BE12	14.0	11.0	35,000	25,200	7.7	33,000	3.4	18,000	2.20	1,275	3/4	3/8	3/4	3/8	3/4	3/8	.071	H4TXV02
	E(C,H,M,U)1P30B	80G1DF090BE16	13.5	11.0	35,000	25,200	7.7	32,800	3.4	18,000	2.20	1,275	3/4	3/8	3/4	3/8	3/4	3/8	.071	H4TXV02
	E(C,H,M,U)1P36B	80G1DF090BE16	13.5	11.0	35,000	25,200	7.7	33,000	3.4	18,000	2.20	1,275	3/4	3/8	3/4	3/8	3/4	3/8	.071	H4TXV02
	E(C,H,M,U)1P30C	80G1DF110CE20	13.5	11.0	35,000	25,200	7.7	32,800	3.4	18,000	2.20	1,275	3/4	3/8	3/4	3/8	3/4	3/8	.071	H4TXV02
	E(C,H,M,U)1P36C	80G1DF110CE20	14.0	11.0	35,000	25,200	7.7	33,000	3.4	18,000	2.20	1,275	3/4	3/8	3/4	3/8	3/4	3/8	.071	H4TXV02
	E(C,H,M,U)1P30B	80G1UH070BE12	13.5	11.0	35,000	25,200	7.7	32,800	3.4	18,000	2.20	1,275	3/4	3/8	3/4	3/8	3/4	3/8	.071	H4TXV02
	E(C,H,M,U)1P36B	80G1UH070BE12	14.0	11.0	35,000	25,200	7.7	33,000	3.4	18,000	2.20	1,275	3/4	3/8	3/4	3/8	3/4	3/8	.071	H4TXV02
	E(C,H,M,U)1P30B	80G1UH090BE16	14.0	11.0	35,000	25,200	7.7	32,800	3.4	18,000	2.20	1,275	3/4	3/8	3/4	3/8	3/4	3/8	.071	H4TXV02
	E(C,H,M,U)1P36B	80G1UH090BE16	14.0	11.0	35,000	25,200	7.7	33,000	3.4	18,000	2.20	1,275	3/4	3/8	3/4	3/8	3/4	3/8	.071	H4TXV02
	E(C,H,M,U)1P30C	80G1UH090CE20	13.5	11.0	35,000	25,200	7.7	32,800	3.4	18,000	2.20	1,275	3/4	3/8	3/4	3/8	3/4	3/8	.071	H4TXV02
	E(C,H,M,U)1P36C	80G1UH090CE20	14.0	11.0	35,000	25,200	7.7	33,000	3.4	18,000	2.20	1,275	3/4	3/8	3/4	3/8	3/4	3/8	.071	H4TXV02
	E(C,H,M,U)1P30C	80G1UH110CE20	13.5	11.0	35,000	25,200	7.7	32,800	3.4	18,000	2.20	1,275	3/4	3/8	3/4	3/8	3/4	3/8	.071	H4TXV02
	E(C,H,M,U)1P36C	80G1UH110CE20	14.0	11.0	35,000	25,200	7.7	33,000	3.4	18,000	2.20	1,275	3/4	3/8	3/4	3/8	3/4	3/8	.071	H4TXV02
	E(C,H,M,U)1P36C	80G2UH0110CV20*	14.0	11.0	35,000	25,200	7.7	33,000	3.4	18,000	2.20	1,275	3/4	3/8	3/4	3/8	3/4	3/8	.071	H4TXV02
	E(C,H,M,U)1P30B	80G2UH090BV16*	13.5	11.0	35,000	25,200	7.7	32,800	3.4	18,000	2.20	1,275	3/4	3/8	3/4	3/8	3/4	3/8	.071	H4TXV02
	E(C,H,M,U)1P36B	80G2UH090BV16*	13.5	11.0	35,000	25,200	7.7	33,000	3.4	18,000	2.20	1,275	3/4	3/8	3/4	3/8	3/4	3/8	.071	H4TXV02
	E(C,H,M,U)1P30C	80G2UH110CV20*	13.5	11.0	35,000	25,200	7.7	32,800	3.4	18,000	2.20	1,275	3/4	3/8	3/4	3/8	3/4	3/8	.071	H4TXV02
	E(C,H,M,U)1P36B	95G1DF070BE16	13.5	11.0	35,000	25,200	7.7	33,000	3.4	18,000	2.20	1,275	3/4	3/8	3/4	3/8	3/4	3/8	.071	H4TXV02
	E(C,H,M,U)1P30C	95G1DF090CE16	13.5	11.0	35,000	25,200	7.7	32,800	3.4	18,000	2.20	1,275	3/4	3/8	3/4	3/8	3/4	3/8	.071	H4TXV02
	E(C,H,M,U)1P36C	95G1DF090CE16	14.0	11.0	35,000	25,200	7.7	33,000	3.4	18,000	2.20	1,275	3/4	3/8	3/4	3/8	3/4	3/8	.071	H4TXV02
	E(C,H,M,U)1P30C	95G1DF110CE20	13.5	11.0	35,000	25,200	7.7	32,800	3.4	18,000	2.20	1,275	3/4	3/8	3/4	3/8	3/4	3/8	.071	H4TXV02
	E(C,H,M,U)1P36C	95G1DF110CE20	13.5	11.0	35,000	25,200	7.7	33,000	3.4	18,000	2.20	1,275	3/4	3/8	3/4	3/8	3/4	3/8	.071	H4TXV02
	E(C,H,M,U)1P30C	95G1UH090CE16	13.5	11.0	35,000	25,200	7.7	32,800	3.4	18,000	2.20	1,275	3/4	3/8	3/4	3/8	3/4	3/8	.071	H4TXV02

Note:

1. Certified in accordance with Unitary Air Conditioner Certification Program, which is based on AHRI Standard 210/240
2. Required to achieve AHRI rating. If NA (Not Applicable) is in the piston column, then TXV is required.
3. A blower time delay relay is standard on all Allied Air Enterprises furnaces and AH products.

* = B or L

B = Wire Guard

L = Louvered

Cooling Performance with Air Handlers and Furnaces 36

Outdoor Model	Indoor Model		Cooling				Heating				CFM	Refrigerant Connection				Refrig. Line Size		Indoor Expansion Device		
	Evaporator Coil or Air Handler ₃	Furnaces	SEER	EER	ARI Rated Capacity ¹	Sensible Capacity	HSPF	47		17		Outdoor		Indoor		Suction	Liquid	Piston ²	TXV	
								Btuh	COP	Btuh		COP	Suction	Liquid	Suction					Liquid
4HP13*36P-7	E(C,H,M,U)1P36C	95G1UH090CE16	14.0	11.0	35,000	25,200	7.7	33,000	3.4	18,000	2.20	1,275	3/4	3/8	3/4	3/8	3/4	3/8	.071	H4TXV02
	E(C,H,M,U)1P30C	95G1UH110CE20	13.5	11.0	35,000	25,200	7.7	32,800	3.4	18,000	2.20	1,275	3/4	3/8	3/4	3/8	3/4	3/8	.071	H4TXV02
	E(C,H,M,U)1P36C	95G1UH110CE20	13.5	11.0	35,000	25,200	7.7	33,000	3.4	18,000	2.20	1,275	3/4	3/8	3/4	3/8	3/4	3/8	.071	H4TXV02
	E(C,H,M,U)1P30B	95G2DF045BV12	13.5	11.0	35,000	25,200	7.7	32,800	3.4	18,000	2.20	1,275	3/4	3/8	3/4	3/8	3/4	3/8	.071	H4TXV02
	E(C,H,M,U)1P36B	95G2DF045BV12	13.5	11.0	35,000	25,200	7.7	33,000	3.4	18,000	2.20	1,275	3/4	3/8	3/4	3/8	3/4	3/8	.071	H4TXV02
	E(C,H,M,U)1P30B	95G2DF070BV16	13.5	11.0	35,000	25,200	7.7	32,800	3.4	18,000	2.20	1,275	3/4	3/8	3/4	3/8	3/4	3/8	.071	H4TXV02
	E(C,H,M,U)1P36B	95G2DF070BV16	13.5	11.0	35,000	25,200	7.7	33,000	3.4	18,000	2.20	1,275	3/4	3/8	3/4	3/8	3/4	3/8	.071	H4TXV02
	E(C,H,M,U)1P30C	95G2DF090CV20	14.0	11.0	35,000	25,200	7.7	32,800	3.4	18,000	2.20	1,275	3/4	3/8	3/4	3/8	3/4	3/8	.071	H4TXV02
	E(C,H,M,U)1P36C	95G2DF090CV20	14.0	11.0	35,000	25,200	7.7	33,000	3.4	18,000	2.20	1,275	3/4	3/8	3/4	3/8	3/4	3/8	.071	H4TXV02
	E(C,H,M,U)1P30C	95G2DF110CV20	14.0	11.0	35,000	25,200	7.7	32,800	3.4	18,000	2.20	1,275	3/4	3/8	3/4	3/8	3/4	3/8	.071	H4TXV02
	E(C,H,M,U)1P36C	95G2DF110CV20	14.0	11.0	35,000	25,200	7.7	33,000	3.4	18,000	2.20	1,275	3/4	3/8	3/4	3/8	3/4	3/8	.071	H4TXV02
	E(C,H,M,U)1P30B	95G2UH045BV12	13.5	11.0	35,000	25,200	7.7	32,800	3.4	18,000	2.20	1,275	3/4	3/8	3/4	3/8	3/4	3/8	.071	H4TXV02
	E(C,H,M,U)1P36B	95G2UH045BV12	13.5	11.0	35,000	25,200	7.7	33,000	3.4	18,000	2.20	1,275	3/4	3/8	3/4	3/8	3/4	3/8	.071	H4TXV02
	E(C,H,M,U)1P30B	95G2UH070BV12	13.5	11.0	35,000	25,200	7.7	32,800	3.4	18,000	2.20	1,275	3/4	3/8	3/4	3/8	3/4	3/8	.071	H4TXV02
	E(C,H,M,U)1P36B	95G2UH070BV12	14.0	11.0	35,000	25,200	7.7	33,000	3.4	18,000	2.20	1,275	3/4	3/8	3/4	3/8	3/4	3/8	.071	H4TXV02
	E(C,H,M,U)1P30C	95G2UH090CV12	14.0	11.0	35,000	25,200	7.7	32,800	3.4	18,000	2.20	1,275	3/4	3/8	3/4	3/8	3/4	3/8	.071	H4TXV02
	E(C,H,M,U)1P36C	95G2UH090CV12	14.0	11.0	35,000	25,200	7.7	33,000	3.4	18,000	2.20	1,275	3/4	3/8	3/4	3/8	3/4	3/8	.071	H4TXV02
	E(C,H,M,U)1P30C	95G2UH090CV20	14.0	11.0	35,000	25,200	7.7	32,800	3.4	18,000	2.20	1,275	3/4	3/8	3/4	3/8	3/4	3/8	.071	H4TXV02
	E(C,H,M,U)1P36C	95G2UH090CV20	14.0	11.0	35,000	25,200	7.7	33,000	3.4	18,000	2.20	1,275	3/4	3/8	3/4	3/8	3/4	3/8	.071	H4TXV02
	E(C,H,M,U)1P30C	95G2UH110CV20	14.0	11.0	35,000	25,200	7.7	32,800	3.4	18,000	2.20	1,275	3/4	3/8	3/4	3/8	3/4	3/8	.071	H4TXV02
E(C,H,M,U)1P36C	95G2UH110CV20	14.0	11.0	35,000	25,200	7.7	33,000	3.4	18,000	2.20	1,275	3/4	3/8	3/4	3/8	3/4	3/8	.071	H4TXV02	

Note:

1. Certified in accordance with Unitary Air Conditioner Certification Program, which is based on AHRI Standard 210/240
2. Required to achieve AHRI rating. If NA (Not Applicable) is in the piston column, then TXV is required.
3. A blower time delay relay is standard on all Allied Air Enterprises furnaces and AH products.

* = B or L

B = Wire Guard

L = Louvered

Cooling Performance with Air Handlers and Furnaces 42, 48, 60

Outdoor Model	Indoor Model		Cooling				Heating				CFM	Refrigerant Connection				Refrig. Line Size		Indoor Expansion Device		
	Evaporator Coil or Air Handler ¹	Furnaces	SEER	EER	ARI Rated Capacity ¹	Sensible Capacity	HSPF	47		17		Outdoor		Indoor		Suction	Liquid	Piston ²	TXV	
								Btuh	COP	Btuh		COP	Suction	Liquid	Suction					Liquid
4HP13*42P-7	BCS2M42V****P		13.0	11.0	41,000	29,520	7.7	40,000	3.5	25,000	2.20	1,400	7/8	3/8	7/8	3/8	7/8	3/8	0.076	H4TXV02
	BCS2M48C****P		13.0	11.0	41,000	29,520	7.7	40,000	3.5	25,000	2.20	1,400	7/8	3/8	7/8	3/8	7/8	3/8	0.076	H4TXV02
	BCS3M42C****P		13.0	11.0	41,000	29,520	7.7	39,000	3.5	25,000	2.20	1,400	7/8	3/8	7/8	3/8	7/8	3/8	0.076	H4TXV02
	BCS3M42E****P		13.5	11.0	41,000	29,520	7.7	39,000	3.5	25,000	2.20	1,400	7/8	3/8	7/8	3/8	7/8	3/8	0.076	H4TXV02
	E(C,H,M,U)1P36C	80G1DF110CE20	13.5	11.0	41,000	29,520	7.7	40,000	3.4	25,000	2.30	1,400	7/8	3/8	3/4	3/8	7/8	3/8	.076	H4TXV02
	E(C,H,M,U)1P36B	80G1UH090BE16	13.5	11.0	41,000	29,520	7.7	40,000	3.4	25,000	2.30	1,400	7/8	3/8	3/4	3/8	7/8	3/8	.076	H4TXV02
	E(C,H,M,U)1P43B	80G1UH090BE16	13.5	11.0	41,000	29,520	7.7	39,500	3.4	25,000	2.30	1,400	7/8	3/8	7/8	3/8	7/8	3/8	.076	H4TXV02
	E(C,H,M,U)1P36C	80G1UH090CE20	13.5	11.0	41,000	29,520	7.7	40,000	3.4	25,000	2.30	1,400	7/8	3/8	3/4	3/8	7/8	3/8	.076	H4TXV02
	E(C,H,M,U)1P36C	80G1UH110CE20	13.5	11.0	41,000	29,520	7.7	40,000	3.4	25,000	2.30	1,400	7/8	3/8	3/4	3/8	7/8	3/8	.076	H4TXV02
	E(C,H,M,U)1P36C	95G1DF110CE20	13.5	11.0	41,000	29,520	7.7	40,000	3.4	25,000	2.30	1,400	7/8	3/8	3/4	3/8	7/8	3/8	.076	H4TXV02
	E(C,H,M,U)1P43C	95G1DF110CE20	13.5	11.0	41,000	29,520	7.7	39,500	3.4	25,000	2.30	1,400	7/8	3/8	7/8	3/8	7/8	3/8	.076	H4TXV02
	E(C,H,M,U)1P36C	95G1UH110CE20	13.5	11.0	41,000	29,520	7.7	40,000	3.4	25,000	2.30	1,400	7/8	3/8	3/4	3/8	7/8	3/8	.076	H4TXV02
	E(C,H,M,U)1P43C	95G1UH110CE20	13.5	11.0	41,000	29,520	7.7	39,500	3.4	25,000	2.30	1,400	7/8	3/8	7/8	3/8	7/8	3/8	.076	H4TXV02
	E(C,H,M,U)1P36C	95G2DF090CV20	13.5	11.0	41,000	29,520	7.7	40,000	3.4	25,000	2.30	1,400	7/8	3/8	3/4	3/8	7/8	3/8	.076	H4TXV02
	E(C,H,M,U)1P36C	95G2DF110CV20	13.5	11.0	41,000	29,520	7.7	40,000	3.4	25,000	2.30	1,400	7/8	3/8	3/4	3/8	7/8	3/8	.076	H4TXV02
	E(C,H,M,U)1P43C	95G2DF110CV20	13.5	11.0	41,000	29,520	7.7	39,500	3.4	25,000	2.30	1,400	7/8	3/8	7/8	3/8	7/8	3/8	.076	H4TXV02
	E(C,H,M,U)1P36C	95G2UH090CV20	13.5	11.0	41,000	29,520	7.7	40,000	3.4	25,000	2.30	1,400	7/8	3/8	3/4	3/8	7/8	3/8	.076	H4TXV02
	E(C,H,M,U)1P43C	95G2UH090CV20	13.5	11.0	41,000	29,520	7.7	39,500	3.4	25,000	2.30	1,400	7/8	3/8	7/8	3/8	7/8	3/8	.076	H4TXV02
E(C,H,M,U)1P36C	95G2UH110CV20	13.5	11.0	41,000	29,520	7.7	40,000	3.4	25,000	2.30	1,400	7/8	3/8	3/4	3/8	7/8	3/8	.076	H4TXV02	
E(C,H,M,U)1P43C	95G2UH110CV20	13.5	11.0	41,000	29,520	7.7	39,500	3.4	25,000	2.30	1,400	7/8	3/8	7/8	3/8	7/8	3/8	.076	H4TXV02	
4HP13*48P-7	BCS2M48V****P		14.0	11.0	48,000	34,560	7.7	45,000	3.2	28,000	2.40	1,600	7/8	3/8	7/8	3/8	7/8	3/8	0.080	H4TXV02
	BCS3M48C****P		13.0	11.0	48,000	34,560	7.7	44,500	3.2	28,000	2.40	1,600	7/8	3/8	7/8	3/8	7/8	3/8	0.080	H4TXV02
	BCS3M48E****P		14.0	11.0	48,000	34,560	7.7	44,500	3.2	28,000	2.40	1,600	7/8	3/8	7/8	3/8	7/8	3/8	0.080	H4TXV02
4HP13*60P-7	BCS2M60V****P		13.0	11.0	58,000	41,180	7.7	54,000	3.3	34,000	2.30	1,850	7/8	3/8	7/8	3/8	1 1/8	3/8	NA	H4TXV02
	BCS3M60C****P		13.0	11.0	57,000	40,500	7.7	55,000	3.3	34,000	2.30	1,850	7/8	3/8	7/8	3/8	1 1/8	3/8	NA	H4TXV02
	BCS3M60E****P		13.0	11.0	57,000	40,500	7.7	55,000	3.3	34,000	2.30	1,850	7/8	3/8	7/8	3/8	1 1/8	3/8	NA	H4TXV02

Note:

1. Certified in accordance with Unitary Air Conditioner Certification Program, which is based on AHRI Standard 210/240
2. Required to achieve AHRI rating. If NA (Not Applicable) is in the piston column, then TXV is required.
3. A blower time delay relay is standard on all Allied Air Enterprises furnaces and AH products.

* = B or L

B = Wire Guard

L = Louvered

Cooling Performance Extended Ratings

Outdoor Model	Indoor Model	Indoor Temp DB/WB °F	Outdoor Temp - DB°F														
			65°			82°			95°			105°			115°		
			Btuh	S/T	kW	Btuh	S/T	kW	Btuh	S/T	kW	Btuh	S/T	kW	Btuh	S/T	kW
4HP13*18P-7	BCS*M18C****P	85/72	22,900	0.62	1.23	21,200	0.64	1.46	19,900	0.65	1.64	18,700	0.67	1.85	17,400	0.68	2.10
		80/67	20,800	0.69	1.23	19,200	0.70	1.48	18,000	0.71	1.67	16,600	0.74	1.62	15,100	0.77	2.10
		75/63	18,800	0.72	1.23	17,300	0.74	1.47	16,100	0.75	1.65	15,100	0.78	1.87	14,000	0.80	2.08
		75/57	16,600	1.00	1.22	15,400	1.00	1.46	14,400	1.00	1.65	13,500	1.00	1.86	12,600	1.00	2.08
4HP13*24P-7	BCS*M24C****P	85/72	26,300	0.58	1.56	25,900	0.62	1.86	25,600	0.65	2.08	24,000	0.68	2.32	22,500	0.71	2.55
		80/67	25,600	0.66	1.56	24,100	0.70	1.86	23,000	0.73	2.08	21,400	0.74	2.31	19,900	0.75	2.53
		75/63	24,500	0.70	1.56	22,900	0.75	1.84	21,700	0.78	2.06	19,900	0.81	2.28	18,200	0.84	2.50
		75/57	21,500	1.00	1.55	19,900	1.00	1.83	18,700	1.00	2.05	17,400	1.00	2.28	16,200	1.00	2.50
4HP13*30P-7	BCS*M30C****P	85/72	34,600	0.60	2.18	33,100	0.63	2.47	32,000	0.66	2.69	30,100	0.68	2.98	28,400	0.70	3.26
		80/67	33,000	0.66	1.98	30,700	0.71	2.32	29,000	0.74	2.59	27,200	0.76	2.91	25,500	0.78	3.23
		75/63	31,000	0.70	1.97	28,800	0.73	2.30	27,200	0.76	2.55	25,000	0.79	2.88	22,900	0.82	3.22
		75/57	26,200	1.00	1.95	24,300	1.00	2.29	23,000	1.00	2.54	21,900	1.00	2.88	21,000	1.00	3.21
4HP13*36P-7	BCS*M36C****P	85/72	40,900	0.61	2.45	39,700	0.67	2.90	38,700	0.71	3.24	36,900	0.70	3.63	35,000	0.69	4.03
		80/67	39,400	0.67	2.42	36,900	0.70	2.81	35,000	0.72	3.11	33,200	0.75	3.52	31,400	0.77	3.93
		75/63	37,200	0.71	2.40	35,100	0.73	2.85	33,400	0.75	3.20	31,400	0.77	3.51	29,400	0.79	3.83
		75/57	32,900	1.00	2.33	31,000	1.00	2.78	29,600	1.00	3.13	27,800	1.00	3.46	26,000	1.00	3.79
4HP13*42P-7	BCS*M42C****P	85/72	48,400	0.60	2.70	46,900	0.63	3.23	45,700	0.65	3.63	43,000	0.68	4.05	40,200	0.70	4.48
		80/67	46,600	0.66	2.69	43,400	0.69	3.22	41,000	0.72	3.62	38,500	0.76	4.02	35,900	0.79	4.42
		75/63	44,200	0.70	2.69	40,900	0.73	3.20	38,400	0.76	3.59	35,700	0.79	3.97	32,800	0.82	4.35
		75/57	38,200	1.00	2.67	35,600	1.00	3.19	33,600	1.00	3.59	31,200	1.00	3.96	28,700	1.00	4.32
4HP13*48P-7	BCS*M48C****P	85/72	55,600	0.62	3.18	53,900	0.64	3.81	52,700	0.66	4.29	49,500	0.69	4.79	46,200	0.71	5.29
		80/67	52,700	0.69	3.14	50,000	0.71	3.75	48,000	0.72	4.23	44,900	0.74	4.71	41,800	0.75	5.19
		75/63	49,800	0.72	3.10	46,700	0.75	3.70	44,400	0.77	4.15	40,800	0.81	4.65	37,200	0.84	5.14
		75/57	43,700	1.00	3.08	40,500	1.00	3.66	38,200	1.00	4.10	35,800	1.00	4.60	33,400	1.00	5.10
4HP13*60P-7	BCS*M60C****P	85/72	72,700	0.59	4.22	67,400	0.62	4.97	63,500	0.64	5.55	59,800	0.66	6.20	56,200	0.67	6.86
		80/67	66,400	0.68	4.12	61,600	0.70	4.81	58,000	0.71	5.35	54,500	0.74	6.06	51,100	0.76	6.77
		75/63	62,300	0.70	4.09	57,100	0.73	4.79	53,100	0.75	5.32	49,900	0.77	6.02	46,800	0.79	6.72
		75/57	52,700	1.00	4.03	48,600	1.00	4.75	45,400	1.00	5.30	42,900	1.00	6.00	40,500	1.00	6.69

Note: Extended data shown is actual for models listed and typical for all AHRI matches.

* = B or L
 B = Wire Guard
 L = Louvered

Heating Performance Extended Ratings

Outdoor Model	Indoor Model	Outdoor Temp. DB/WBoF									
		0/0		17/15		35/33		47/43		62/56	
		Btuh	kW	Btuh	kW	Btuh	kW	Btuh	kW	Btuh	kW
4HP13*18P-7	BCS*M18C****P	6800	1.41	10000	1.46	13000	1.51	17000	1.56	20500	1.61
4HP13*24P-7	BCS*M24C****P	10900	1.70	13000	1.73	17000	1.84	21600	1.92	25500	1.99
4HP13*30P-7	BCS*M30C****P	14500	2.00	17000	2.10	19000	2.26	27000	2.33	32300	2.38
4HP13*36P-7	BCS*M36C****P	13400	2.34	18000	2.40	23000	2.50	33800	2.91	40200	3.01
4HP13*42P-7	BCS*M42C****P	21400	3.10	25000	3.15	29000	3.33	40000	3.35	47500	3.44
4HP13*48P-7	BCS*M48C****P	24900	3.23	28000	3.42	34000	4.11	45000	4.12	53000	4.34
4HP13*60P-7	BCS*M60C****P	29500	4.21	34000	4.33	36000	4.67	55000	4.88	64200	5.10

Note:

Extended data shown is actual for models listed and typical for all AHRI matches.

* = B or L

B = Wire Guard

L = Louvered

Accessories

Description	Where Used	Kit Number
Crankcase Heater	18, 24, 30, 36	93M04
	42, 48, 60	93M05 (factory Installed)
Compressor Low Ambient Kit	18, 24, 30, 36, 42, 48, 60	45F08
Sound Blanket	18, 24, 30, 36	14W00
	42, 48, 60	14W01
Short Cycle Protector	18, 24, 30, 36, 42, 48, 60	47J27 (factory installed, control board feature)
Freezestat	3/8 tubing	93G35
	5/8 tubing	50A93
Time Delay Relay	18, 24, 30, 36, 42, 48, 60	58M81 (factory Installed; control board feature)
Loss of Charge Kit	18, 24, 30, 36, 42, 48, 60	84M23 (factory Installed)



1-800-448-5872

All specifications and illustrations subject to change
without notice and without incurring obligations.