

5

4

3

2

1

C

C

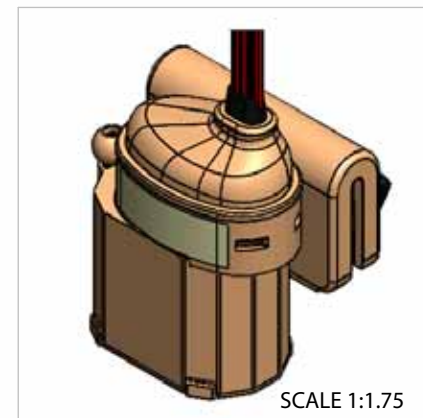
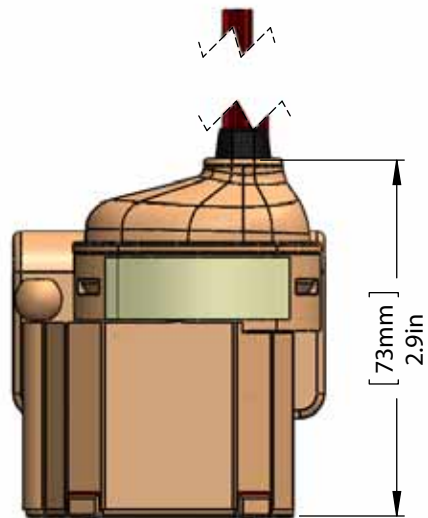

B

B

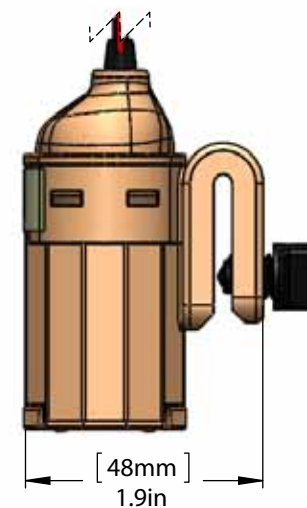
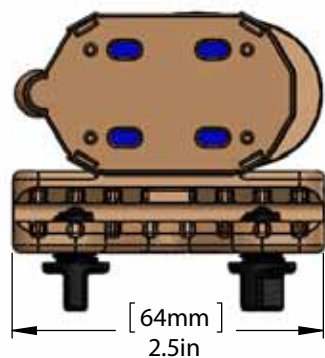

ENGINEERING	NAME	DATE
DRAWN BY ENG.	DS	04/22/10
CHECKED BY ENG.	JK	04/22/10
ENG APPR.	CC	04/22/10
MFG APPR.	CC	04/22/10



2601 Spenwick Drive,
Houston, TX 77055
800-231-3345

A

TITLE:

AG-1100+ SPECIFICATION SHEET

SIZE
A

SCALE: 1:1.5

SHEET 1 OF 1

NOTES:

AG-1100+ 24 VAC,
5.0 AMPS BREAKING/ CARRING

UNLESS OTHERWISE SPECIFIED:

PROPRIETARY AND CONFIDENTIAL

DIMENSIONS ARE IN INCHES
TOLERANCES:
FRACTIONAL ±.032
ANGULAR: MACH ±.5 ° BEND ±2°
TWO PLACE DECIMAL ±.010
THREE PLACE DECIMAL ±.005

THE INFORMATION CONTAINED IN THIS
DRAWING IS THE SOLE PROPERTY OF
RECTORSEAL.
ANY REPRODUCTION IN PART OR AS A
WHOLE WITHOUT THE WRITTEN
PERMISSION OF RECTORSEAL IS
PROHIBITED.

INTERPRET GEOMETRIC
TOLERANCING PER: ANSI Y14.5, 1994

5

4

3

2

1