



INSTALLATION INSTRUCTIONS

SEP

100,000 to 400,000 Btuh Series

UNIT HEATERS

IM-SEP-0652453-07
November 2011
Supersedes 65245306

Table Of Contents

SEP Unit Dimensions	2	Unit Start-Up	12
Shipping	3	To Turn Off Gas to Unit	14
Optional Accessories	3	Heating Sequence of Operation	14
CSA Requirements in USA	4	Ignition Control LED	14
CSA Requirements in Canada	4	High Altitude Adjustment	14
Additional Requirements	5	Gas Flow	16
Unit Heater Installation	5	Gas Pressure Adjustment	16
Combustion and Ventilation Air	5	Limit Control Switch	16
Rotation of Combustion Air Inducer	5	Louver Vane Adjustments	16
Venting	6	Combustion Air Pressure Switch	16
Electrical Connections	11	Service	16
Typical SEP Wiring Diagram	11	Start-Up and Performance Checklist	17
Gas Connection	12	Template	18
Leak Check	12	Warranty	19

RETAIN THESE INSTRUCTIONS FOR FUTURE REFERENCE



⚠ WARNING

FIRE OR EXPLOSION HAZARD.

Failure to follow safety warnings exactly could result in serious injury, death, or property damage.



Be sure to read and understand the installation, operation and service instructions in this manual.

Improper installation, adjustment, alteration, service or maintenance can cause serious injury, death or property damage.

Do not store or use gasoline or other flammable vapors and liquids in the vicinity of this or any other appliance.

Installation and service must be performed by a qualified installer, service agency or the gas supplier.

WHAT TO DO IF YOU SMELL GAS:

- Do not try to light any appliance.
- Do not touch any electrical switch; do not use any phone in your building.
- Leave the building immediately.
- Immediately call your gas supplier from a neighbor's phone. Follow the gas supplier's instructions.
- If you cannot reach your gas supplier, call the fire department.

SEP Unit Dimensions

NOTE – SEP models 100, 115, 145, 175 and 200 have a single fan. SEP models 230, 250, 300, 345 and 400 have two fans.

NOTE – Two mounting nuts are furnished on SEP models 100, 115, 145, 175 and 200. Four mounting nuts are furnished on SEP models 230, 250, 300, 345 and 400 models.

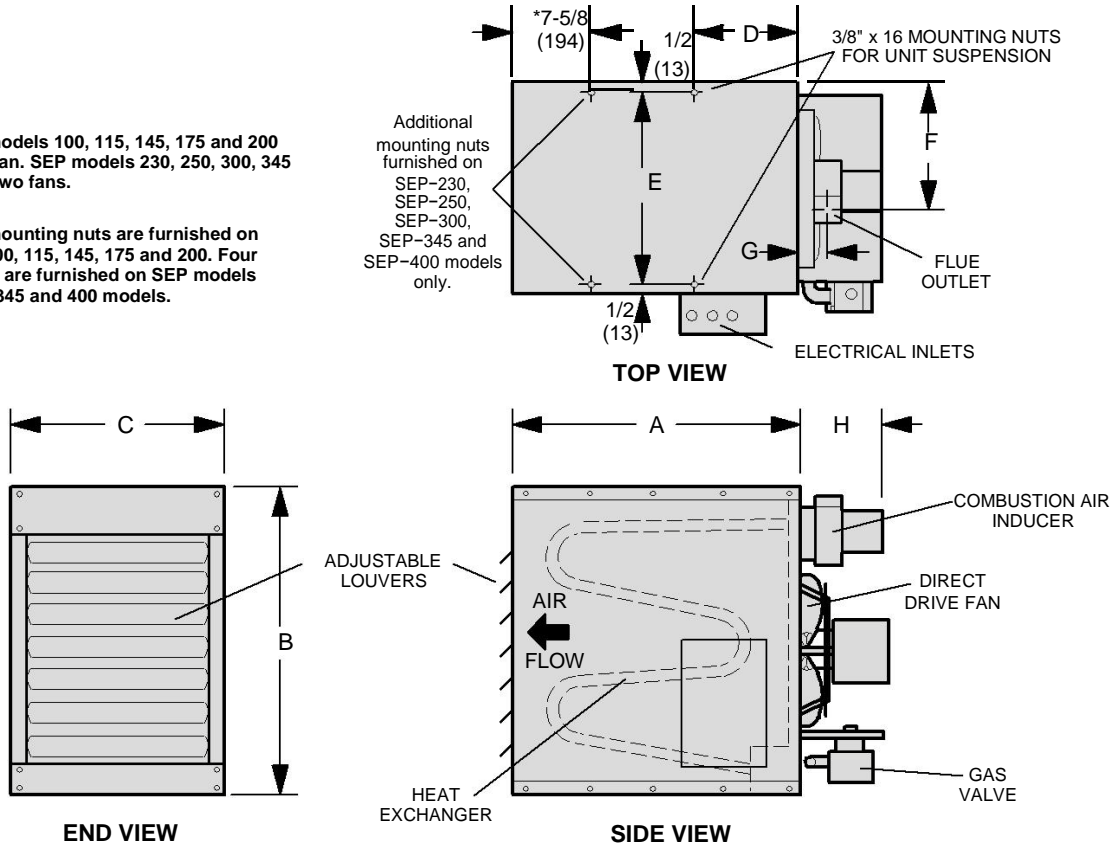

Unit	A		B		C		D		E		F		G		H	
	in.	mm	in.	mm	in.	mm	in.	mm	in.	mm	in.	mm	in.	mm	in.	mm
SEP-100 SEP-115 SEP-145	31-5/16	795	32-3/16	817	20-3/16	512	11-1/2	292	19-1/16	484	11-3/4	298	3-1/4	83	7-7/8	200
SEP-175 SEP-200	31-5/16	795	32-3/16	817	23-1/8	588	11-1/2	292	22-1/16	560	8-1/2	216	3-1/4	83	8-11/16	220
SEP-230* SEP-250* SEP-300*	31-5/16	795	32-3/16	817	41-1/8	1045	3-11/16	97	40	1016	17-3/4	451	3-1/2	89	8-11/16	220
SEP-345* SEP-400*	31-5/16	795	32-3/16	817	41-1/8	1045	3-11/16	97	40	1016	17-1/2	445	3-1/2	89	9-13/16	248

*Unit contains dual fans.

Shipping

The heater is completely assembled and is shipped with installation and operating instructions, warranty certificate and flue transition. Check the unit for shipping damage. The receiving party should contact the last carrier immediately if any shipping damage is found.

Optional Accessories

TABLE 1

SEP-100 to SEP-230						
Gas Heating Performance	Part No. – Stainless Steel	SEP-100S	SEP-115S	SEP-145S	SEP-175S	SEP-200S
	Part No. – Aluminized Steel	SEP-100A	SEP-115A	SEP-145A	SEP-175A	SEP-200A
Hanging Bracket Kit	100001381	X	X	X	X	X
High Altitude Pressure Switch Kit	176722600	X ¹	X ¹	X ¹	X ²	---
LPG/Propane Kit	165296401	X				
	165295202		X	X	X	
	165295205					X
	165295203					

¹ SEP-100 through -145 require replacement combustion air inducer pressure switch at altitudes over 5500 feet above sea level.

² SEP-175 requires replacement combustion air inducer pressure switch at altitudes over 2500 feet above sea level.

TABLE 2

SEP-230 to SEP-400						
Gas Heating Performance	Part No. – Stainless Steel	SEP-230S	SEP-250S	SEP-300S	SEP-345S	SEP-400S
	Part No. – Aluminized Steel	SEP-230A	SEP-250A	SEP-300A	SEP-345A	SEP-400A
Optional Accessories – Must Be Ordered Extra						
Hanging Bracket Kit	100001381	X	X	X	X	X
LPG/Propane Kit	165296403		X	X		
	165295203	X			X	
	165295206					X

CSA Requirements in USA

Installation of gas unit heaters must conform with local building codes or, in the absence of local codes, with the current edition of ANSI-Z223.1, National Fuel Gas Code.

Installation in aircraft hangers must be in accordance with the current edition of ANSI/NFPA No. 409, Standard for Aircraft Hangers.

Installation in parking structures must be in accordance with the current edition of ANSI/NFPA No. 88A, Standard for Parking Structures.

Installation in repair garages must be in accordance with the current edition of ANSI/NFPA No. 88B, Standard for Repair Garages.

Authorities having jurisdiction should be consulted before installation. Air for combustion and ventilation must conform to the methods outlined in the current edition of ANSI Z223.1, Section 5.3, Air for Combustion and Ventilation, or applicable provisions of local building codes.

The National Fuel Gas Code (ANSI-Z223.1) is available from:

American National Standard Institute Inc.
11 West 42nd Street
New York, NY 10036

These units are CSA international design-certified. These unit heaters are certified for clearances to combustible material as listed in table 1 and on unit rating plate.

Accessibility and service clearances must be observed in addition to fire protection clearances.

All electrical wiring and grounding for unit must be in accordance with the regulations of the current edition of ANSI/NFPA No. 70, National Electric Code.

The National Electric Code is available from:

*National Fire Protection Association
1 Batterymarch Park
PO Box 9101
Quincy, MA 02269-9101*

CSA Requirements in Canada

These instructions are intended only as a general guide and do not supersede local codes in any way. Authorities having jurisdiction should be consulted before installation. The installation must conform with local building codes or, in the absence of local codes, with the current edition of CSA-B149 installation compliance codes. All electrical wiring and grounding for the unit must also comply with the current edition of CSA C22.1, Canadian Electrical Code.

These unit heaters are CSA-certified for clearances to combustible material listed on the rating plate and table 3. Adequate clearance must be provided around the appliance and around air openings into the combustion chamber. Provision must be made for service accessibility.

NOTE: Fire protection clearances may be exceeded to provide additional space for service and accessibility.

**TABLE 3
UNIT CLEARANCES TO COMBUSTIBLE MATERIALS**

Top		Sides		Bottom		Rear		Flue	
in	mm	in	mm	in	mm	in	mm	in	mm
6	152	6	152	0	0	18	457	6	152

GARAGE / WAREHOUSE INSTALLATIONS

- 1 - In a storage area, clearance from the heater to combustible materials must be such that the combustible material must not attain a temperature above 160°F (71°C) during continuous operation of the unit.

⚠ WARNING

Combustible materials that are affected by exposure to temperatures less than 160°F (plastics, plastic wrap, styrofoam, cardboard, etc.) must be stored well away from this heater. Discharge air temperatures for these units can approach 200°F.

- 2 - Maintain an 8-foot (2.5 m) minimum clearance from the floor to the bottom of the heater. Refer to the current edition of CSA-B149 installation compliance codes.

AIRCRAFT HANGER

- 1 - In an area where aircraft are housed or serviced, a 10-foot (3 m) minimum clearance from the highest surface of the aircraft to bottom of the heater must be maintained.
- 2 - In other areas, an 8-foot (2.5m) minimum clearance from the floor to bottom of heater must be maintained.
- 3 - Heaters should be located so that they are protected from damage from aircraft or other appliances needed for servicing of aircraft. Refer to requirements of the enforcing authorities.

In a confined area, the heater must be installed in accordance with the current edition of CSA-B149 installation compliance codes. Be sure to check with local codes and ordinances for additional requirements.

Additional Requirements

The Commonwealth of Massachusetts stipulates the following additional requirements:

- 1 – Gas furnaces shall be installed by a licensed plumber or gas fitter only.
- 2 – The gas cock must be "T handle" type.

Unit Heater Installation

⚠ WARNING

Improper installation, adjustment, alteration, service or maintenance can cause property damage, personal injury or loss of life. Installation and service must be performed by a licensed professional installer (or equivalent), service agency or the gas supplier.

⚠ CAUTION

As with any mechanical equipment, personal injury can result from contact with sharp sheet metal edges. Be careful when you handle this equipment.

The appliance shall not be installed downstream from evaporator coils or cooling units.

Install the unit in the desired location as governed by clearances, vent connection, air direction, gas supply, electrical supply and service accessibility.

On SEP models 100, 115, 145, 175, and 200, mounting nuts are furnished at the balance point (two positions only). On SEP models 230, 250, 300, 345 and 400, mounting nuts are furnished at each corner of the unit. Mounting nuts will accommodate 3/8" x 16 threaded rods.

- 1 – Cut threaded rods to desired length and slide a 3/8" nut onto the rod.
- 2 – Slide a flat washer onto the threaded rod AFTER the nut (7/16" inside diameter X 1" outside diameter X 1/16" thick washer).
- 3 – Screw the rods (two or four) into the mounting nuts on the unit.
- 4 – Tighten nuts to secure unit to rods.

⚠ IMPORTANT

Do not use the gas manifold pipe to lift unit. Any excessive upward or downward force on the manifold pipe and bracket assembly can cause the ignition burner and igniter to become misaligned.

**TABLE 4
MAXIMUM MOUNTING HEIGHTS**

Model Number	Feet (Meters)
SEP-100 and SEP-115	16 (4.9)
SEP-145, SEP-175, and SEP-200	20 (6.1)
SEP-230, SEP-250, SEP-300, SEP-345 and SEP-400	30 (9.1)

Combustion and Ventilation Air

Adequate facilities for supplying air for combustion and ventilation must be provided in accordance with the current edition of ANSI Z223.1, section 5.3, and CSA-B149 installation compliance codes, or applicable provisions of local building codes.

All gas-fired appliances require air to be used for the combustion process. In many buildings today, there is a negative indoor air pressure caused by exhaust fans, etc.

If sufficient quantities of combustion air are not available, the heater or another appliance will operate in an inefficient manner, resulting in incomplete combustion which can result in the production of excessive carbon monoxide.

⚠ CAUTION

Insufficient combustion air can cause headaches, nausea, dizziness, asphyxiation or death.

If indoor air is to be used for combustion, it must be free of the following substances or the life of the heat exchanger will be adversely affected: chlorine, carbon tetrachloride, cleaning solvent, halogen refrigerants, acids, cements and glues, printing inks, fluorides, paint removers, varnishes, or any other corrosives.

Rotation of Combustion Air Inducer (SEP-100, -115 and -145 Only)

The combustion air inducer on SEP models -100, -115 and -145 may be rotated 90° either to the left or right of the original vertical position in order to better suit the application.

NOTE – It is not permissible to rotate the combustion air inducer on SEP models -175, -200, -230, -250, -300, -345 and -400.

Rotate the combustion air inducer assembly as follows:

- 1 – Remove the heater from the carton. Decide the best unit heater orientation. The vent can be installed in one of three discharge positions: up, left, or right.

- 2 - If the inducer is to be rotated, follow the instructions in this section; otherwise, refer to instructions under Venting" section.
- 3 - Before making an electrical or gas connections, remove the securing screws on the flue box/combustion air inducer. See figure 1.

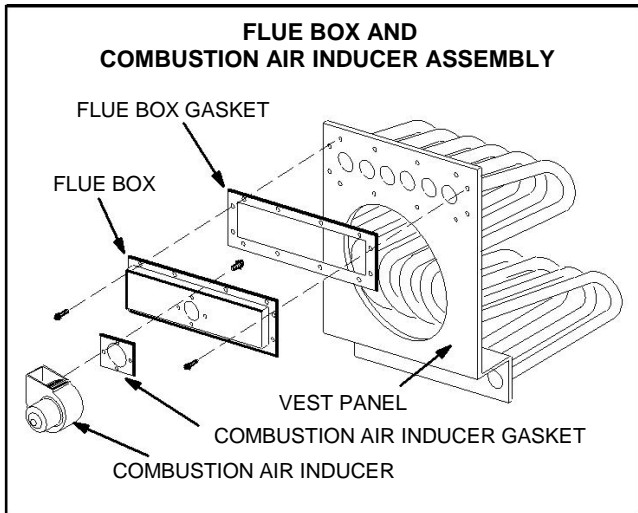

FIGURE 1

- 4 - Remove the flue box/combustion air inducer assembly, ensuring that the gasket is not damaged. If the gasket is damaged, replace it.
- 5 - Use a 1/4" socket to remove the three screws which secure the combustion air inducer to the flue box.
Remove the inducer and gasket from the flue box ensuring that the gasket is not damaged. If the gasket is damaged, replace it.
- 6 - Use the template provided in the back of this manual to mark new hole locations. Use a 7/32" drill bit to drill holes in flue box.
- 7 - Place the gasket between the combustion air inducer and the flue box. Rotate both the inducer and the gasket 90° to the desired position. Reinsert and tighten the three inducer securing screws (#8-16 X 1/2" HWHSMS).
- 8 - Place the gasket between the flue box and the vest panel. Position the flue box/combustion air inducer assembly on the vest panel. Fasten the flue box to the vest panel using the flue box securing screws (#10-16 X 5/8" HWHSMS) and a 5/16" driver.

- 9 - The unit heater is now ready for installation as described in the Venting section.

Venting

NOTE - The vent is a passageway, vertical or nearly so, used to convey flue gases from an appliance, or its vent connector, to the outside atmosphere. The vent connector is the pipe or duct that connects a fuel-gas burning appliance to a vent or chimney.

NOTE - Local codes may supersede any of these provisions.

GENERAL RECOMMENDATION AND REQUIREMENTS

SEP unit heaters must be vented in compliance with the latest edition of the National Fuel Gas Code (NFPA 54 / ANSI Z223.1) in the USA and with CSA-B149.1 codes in Canada, as well as applicable provisions of local building codes, and the following instructions.

A sheet metal flue transition is supplied with this certified unit. It must not be modified or altered and must be installed on the outlet of the combustion air inducer assembly prior to the installation of the vent connector. Failure to comply with this requirement will void the certification of the unit by the approval agencies.

A single-wall vent connector may be used in all applications between the furnace and the vertical vent pipe.

A single-wall vent pipe used as a vent connector or as a vertical vent, must have all seams and joints sealed with pressure-sensitive aluminum tape or silicone rubber sealant. Aluminum tape must meet the provisions of SMACNA AFTS-100-73 Standards. The aluminum tape must have a temperature rating of 400°F (204°C).

Silicone rubber sealant must have a temperature rating of 482°F (250°C), i.e., Dow Corning RTV-736 or equivalent.

All joints must be secured with at least two corrosion resistant screws. All joints must be checked for gas tightness after installation. Single-wall vent pipe used as vertical vent must not pass through any attic, interior wall, concealed space, or floor.

VERTICAL VENTS USING METAL VENT PIPE

All SEP unit heaters are listed as Category 1 appliances for vertical vent installations.

- 1 - All SEP unit heaters are to be used with NFPA- or ANSI-approved chimneys or U.L.-listed type B-1 gas vents where applicable, as well as the modifications and limitations listed in figure 2. Seal single-wall vent material according to **General Recommendations and Requirements section**.
- 2 - Keep the vent connector runs as short as possible with a minimum number of elbows. Refer to the current edition of ANSI Z223.1 or CSA-B149 installation compliance codes for maximum vent and vent connector lengths. Horizontal run of the vent connector from the combustion air inducer outlet to the chimney/vent pipe cannot exceed the values in table 6. Single-wall vent connectors shall not be insulated.

**TABLE 5
VENT CONNECTOR DIAMETERS**

Model Number	Connector Diameter
SEP-100 SEP-115 SEP-145	4" (102mm)
SEP-175 SEP-200 SEP-230 SEP-250 SEP-300	5" (127mm)
SEP-345 SEP-350 SEP-400*	6" (152mm)

* On SEP-400 models, a minimum 6" (162mm) straight section must be placed between the flue transition and the first elbow of the vent.

A single 3" (76 mm), 4" (102mm), or 5" (127 mm) elbow is equivalent to 5 feet (1.53 m) of vent pipe. A single 6" (152mm) elbow is equivalent to 9 feet (2.75 m) of vent pipe.

Single-wall vent connector shall not be insulated.

- 3 - All SEP models may be vented vertically as a single appliance, or as a common vent with other gas-fired appliances. In a common venting situation, vent connectors for other appliances must be joined to the vent at least 4" (102 mm) above the connected SEP connection. When common venting with another SEP unit, maintain at least a 4" (102 mm) vertical separation between the vent connectors.
- 4 - Clearance to combustible material is 6" (152mm) for single-wall vent material except where a listed clearance thimble is used. Clearance to combustible material for type B-1 vent or factory-built chimney is per manufacturer's instructions.
- 5 - The vent connector must be supported with hangers no more than three feet (1m) apart to prevent movement after installation. All horizontal vent connector runs must have a slope up to the vertical vent of at least 1/4" per foot (1mm per 50mm).
- 6 - All vertical vents must be terminated with a UL-listed (or other equivalent agency) vent cap or rain shield assembly unless local codes permit otherwise.
- 7 - The vent pipe must extend at least 3 feet (1m) above the highest point where it passes through a roof of a building. The vent must also extend at least two feet higher than any part of a building within a horizontal distance of 10 feet (3.05 m) unless otherwise specified by the ANSI Z223.1 or CSA-B149 installation compliance codes. The vent must extend at least 5 feet (1.53 m) above the highest connected equipment flue collar.

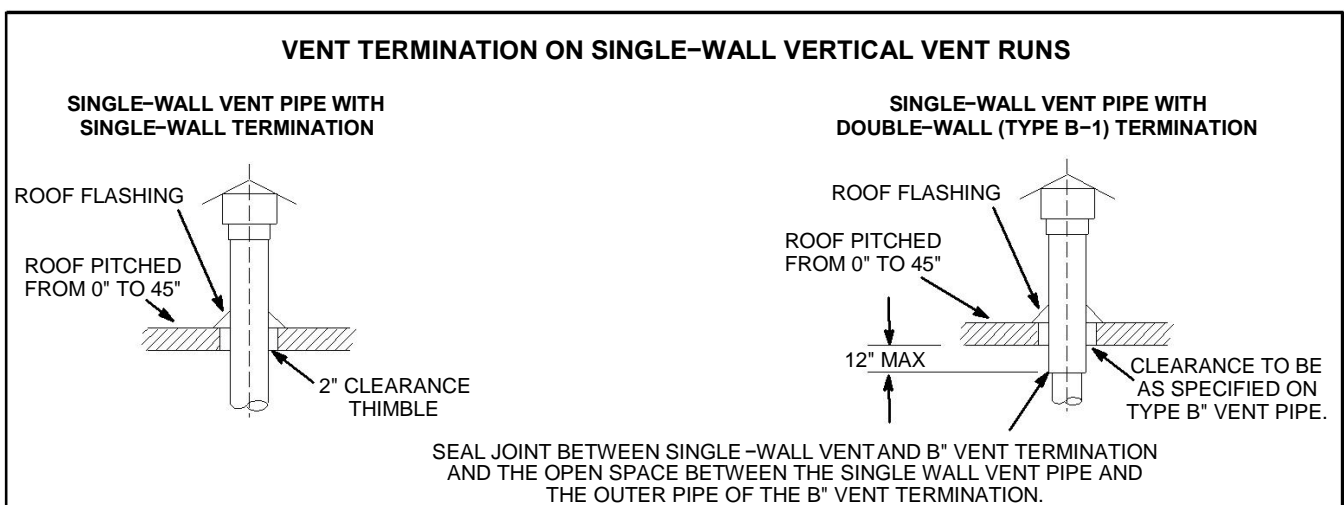

FIGURE 2

**TABLE 6
MAXIMUM HORIZONTAL VENT CONNECTOR AND
HORIZONTAL VENT PIPE LENGTHS**

No. of Elbows	SEP-100, -115, -145, -175, and -200		SEP-230, -250 and -300		SEP-345		SEP-400	
	ft	m	ft	m	ft	m	ft	m
1	25	7.6	35	10.7	31	9.4	21	6.4
2	20	6.1	30	9.1	22	6.7	12	3.6
3	15	4.6	25	7.6	13	4.0	3	0.9
4	10	3.0	20	6.1	4	1.2	--	--
5	5	1.5	15	4.6	--	--	--	--
6	--	--	10	3.0	--	--	--	--
7	--	--	5	1.5	--	--	--	--

HORIZONTAL VENTING

NOTE – Common venting is not allowed when horizontally venting the unit heater.

If the SEP unit heater is to be horizontally vented, a positive pressure may be created in the vent. The unit heater, when installed with horizontal venting, will perform as a category III appliance.

- 1 – **Special vent materials approved for use with Category III appliances may be used with these units.** Refer to table 7 for venting components.
- 2 – If possible, do not terminate the horizontal vent through a wall that is exposed to prevailing wind. Exposure to excessive winds can affect unit performance. If such a termination is necessary, use a wind block to protect the vent termination from direct winds.
- 3 – Vent termination must be free from obstructions and at least 12" (30.5 cm) above grade level and maximum snow height.
- 4 – Do not terminate vent directly below roof eaves or above a public walkway, or any other area where condensate dripping may be troublesome and may cause some staining. Avoid windows where steam may cause fogging or ice buildup.
- 5 – Minimum clearance for horizontal vent termination from any door, window, gravity air inlet, gas or electric meter, regulators, and relief equipment is 4 feet (1m) for United States installations.

In Canada, horizontal vent termination must have a minimum 6-foot horizontal clearance from gas and electric meters and relief devices.

Refer to latest editions of the ANSI Z223.1 or CSA-B149 for installation compliance codes and with local authorities with jurisdiction.

- 6 – Vent termination must be a minimum of 4 feet (1.2m) horizontally from any soffit or under-eave vent.
- 7 – Vent termination must be a minimum of 6 feet (1.83 m) from an inside corner formed by two exterior walls. If possible, leave a 10-foot clearance.
- 8 – Vent termination must be a minimum of 10 feet (3m) from any forced air inlet (includes fresh air inlet for other appliances, such as a dryer).
- 9 – For upward sloped vent, a condensate tee and drain must be installed within the first 5 feet (2m) from the unit heater to protect the appliance. If the unit is shut down for an extended period of time and will be exposed to sub-freezing temperatures, the condensate may freeze.
- 10 – For upward sloped vent, see figure 3, condensate tee and drain must be installed within the first 5 feet (1.53 m) from the unit heater to protect the appliance.
- 11 – Flexible loop trap in condensate line (if used) must be filled with water to prevent combustion products from entering structure.
- 12 – Select a wall termination point that will maintain 1/4" rise per foot slope of horizontal run of vent pipe. In areas where authorities having jurisdiction permit, a downward slope of maximum 1/4" per foot is also acceptable. Condensate drainage can be collected in a tee pipe section (figure 4) with drain loop similar to one used for upward slope vent, or allowed to drip through the vent termination, if permitted by authorities (figure 5).
- 13 – For horizontal venting, the vent pipe must be supported with hangers no more than 3 feet (1m) apart to prevent movement after installation.
- 14 – All horizontal vent applications which use Category III vent pipe must terminate with an approved Category III tee. Opening end must face downward.
- 15 – When termination is routed through an exterior combustible wall, the vent must be supported using a listed clearance thimble. Inside edge of vent termination tee or elbow must be at least 12" (305mm) from outside wall.

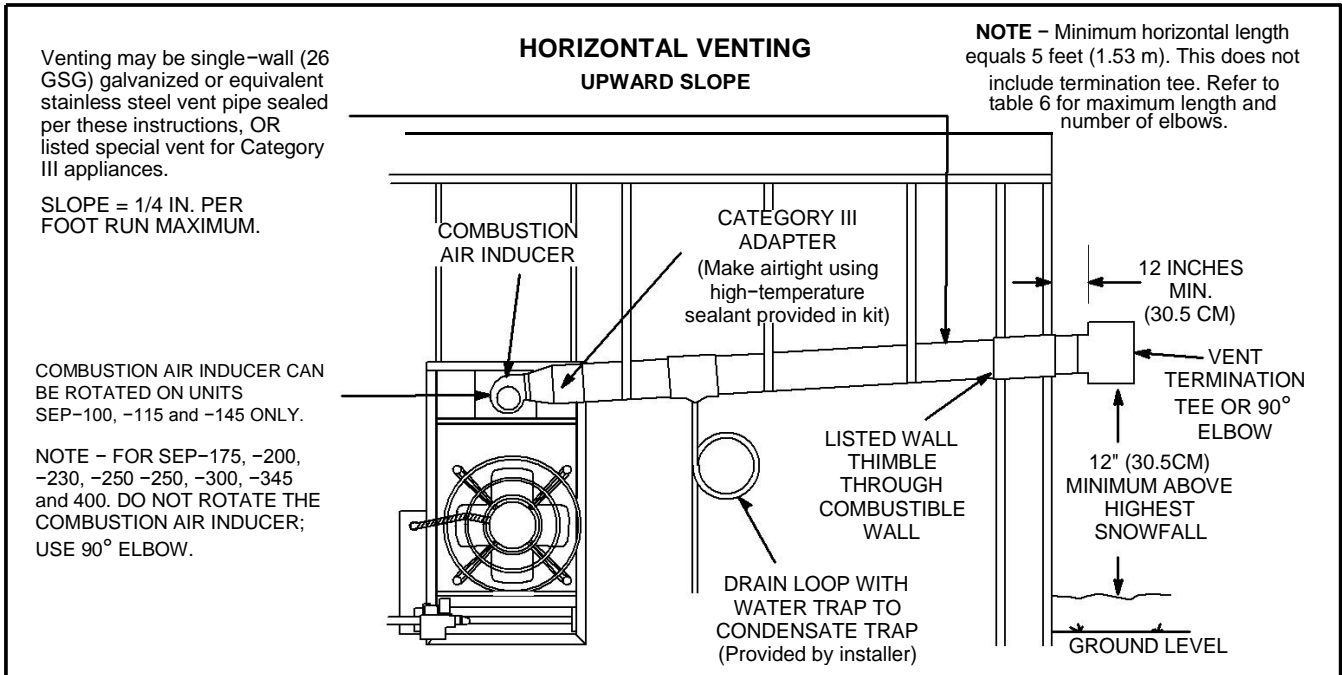

FIGURE 3

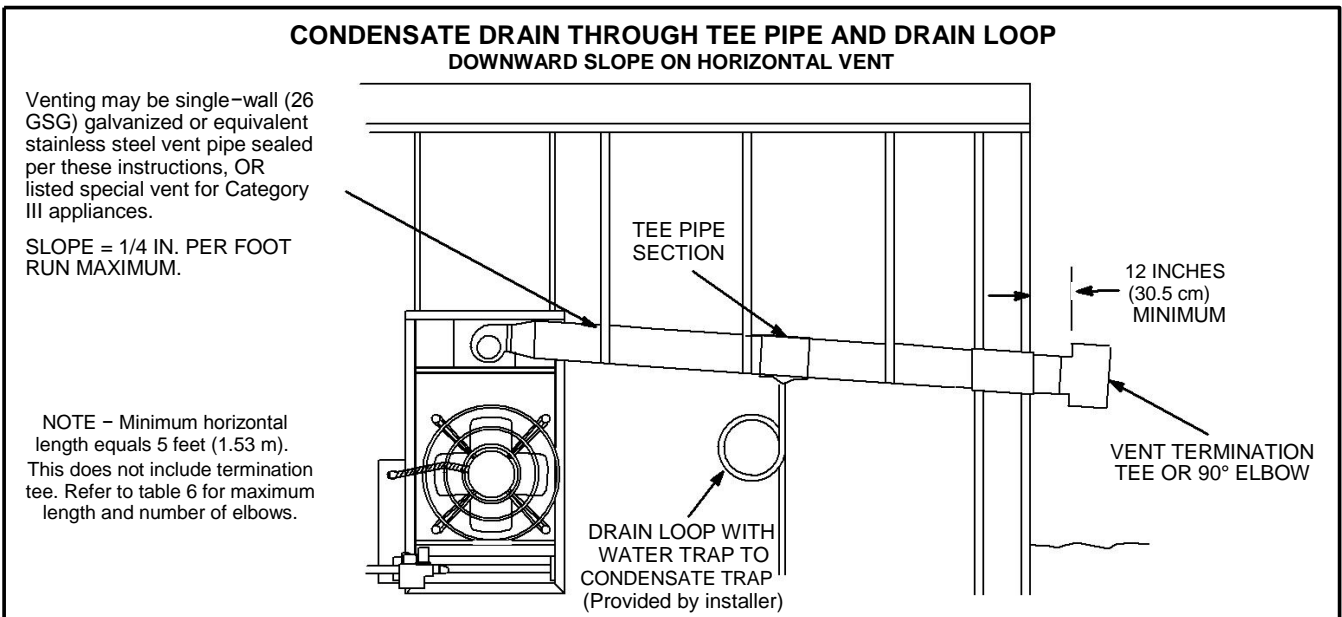

FIGURE 4

**CONDENSATE DRAIN THROUGH VENT TERMINATION
DOWNWARD SLOPE ON HORIZONTAL VENT**

Venting may be single-wall (26 GSG) galvanized or equivalent stainless steel vent pipe sealed per these instructions, OR listed special vent for Category III appliances.

SLOPE = 1/4 IN. PER FOOT RUN MAXIMUM.

NOTE - Minimum horizontal length equals 5 feet (1.53 m). This does not include termination tee. Refer to table 6 for maximum length and number of elbows.

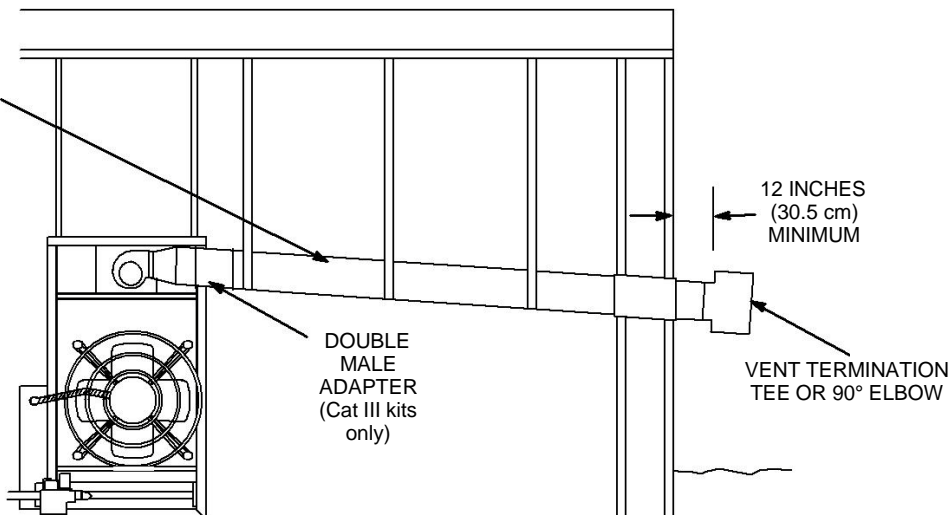

FIGURE 5

**TABLE 7
Category III Horizontal Venting Components
(Required for Horizontal Vent Applications)**

Unit	Part Number	Description
SEP-100 SEP-115 SEP-145	66808902	4" upward sloped Cat III vent kit
	66809002	4" downward sloped Cat III vent kit
	66809102	4" 90° elbow Cat III (optional)
	66809301	4" straight pipe (length = 6")
	66809302	4" straight pipe (length = 12")
	66809303	4" straight pipe (length = 36")
SEP-175 SEP-200 SEP-230 SEP-250 SEP-300	66808903	5" upward sloped Cat III vent kit
	66809003	5" downward sloped Cat III vent kit
	66809103	5" 90° elbow Cat III (optional)
	66809401	5" straight pipe (length = 6")
	66809402	5" straight pipe (length = 12")
	66809403	5" straight pipe (length = 36")
SEP-345 SEP-400	66808904	6" upward sloped Cat III vent kit
	66809004	6" downward sloped Cat III vent kit
	66809104	6" 90° elbow Cat III (optional)
	66809501	6" straight pipe (length = 12")
	66809502	6" straight pipe (length = 36")

Electrical Connections

NOTE – Local codes may supersede any of the provisions outlined in this instruction.

The SEP series unit heaters use a direct spark ignition system. There is no pilot necessary as the spark lights the main burner as the gas valve is turned on. The direct spark ignition control board emits radio noise as the sparking process is under way. The level of energy may be sufficient to disturb a logic circuit in a microprocessor controlled thermostat. It is recommended that an isolation relay be used when connecting the SEP series unit heaters to a microprocessor-controlled thermostat. Install the thermostat according to instructions provided by the manufacturer. Install a separate fused disconnect switch, with the fuse sized according to blower motor size.

Connect wiring through knockout on the junction box located on the side of the unit heater. Refer to heater wiring diagram for connection information. Use 18 gauge wire or larger for thermostat connections.

NOTE – Electrically ground unit in accordance with local codes or, in the absence of local codes, in accordance with the current National Electrical Code (ANSI/NFPA No. 70) in the U.S.A., and in Canada with the current Canadian Electrical Code, Part 1 (CSA C22.1).

NOTE – Uninsulated ground wires must be wrapped in electrical tape to avoid damage to the electrical system.

Connect field wiring as shown on wiring diagram on unit. Also refer to typical diagram in this manual. An additional thermostat wire must be run to terminal G" on heater when continuous blower is desired.

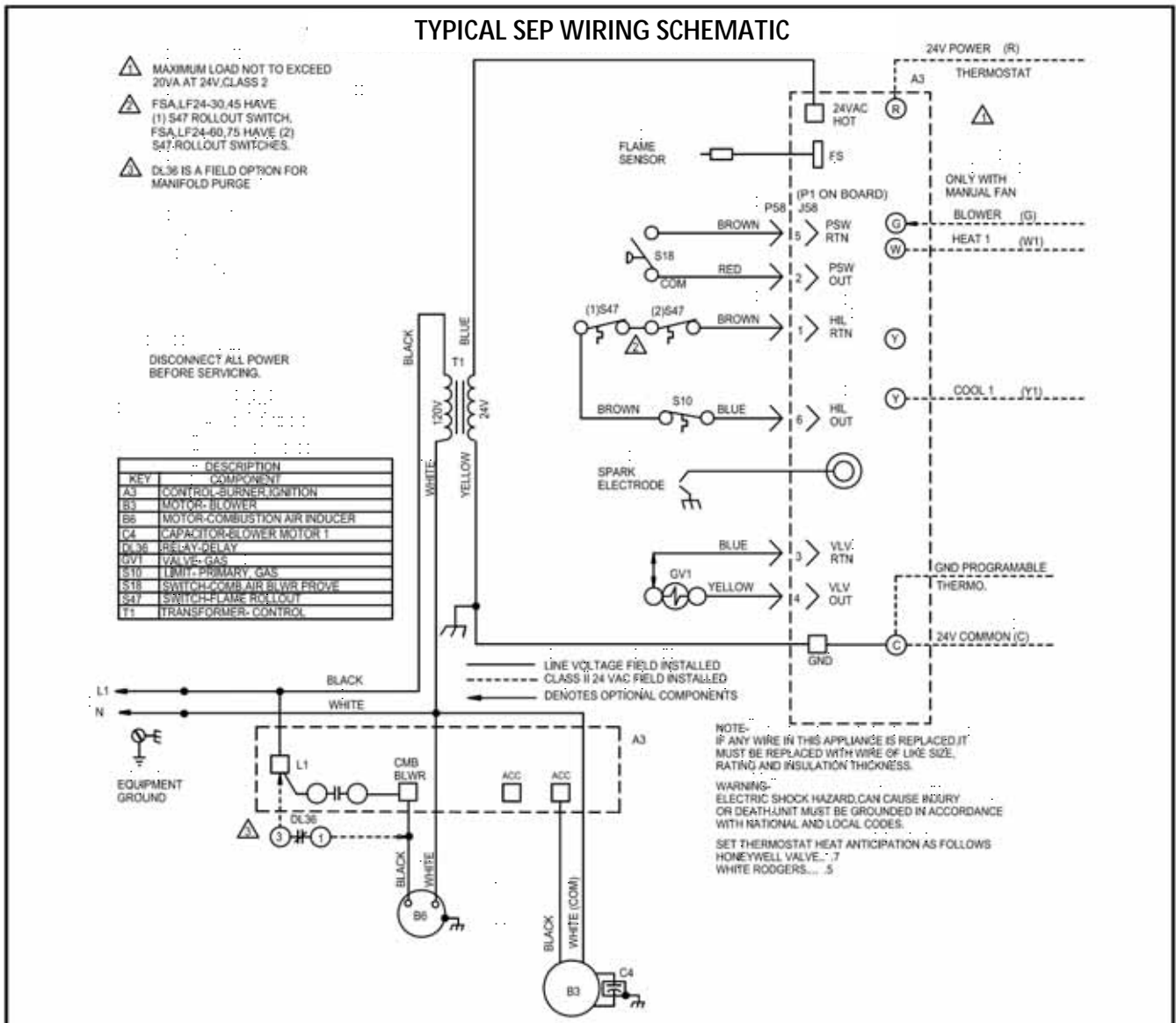

Gas Connection

When connecting gas supply, the length of the run from the meter must be considered in determining the pipe size to avoid excessive pressure drop. A line pressure of 7" w.c. (178 mm w.c.) for natural gas should be maintained when sizing piping. For correct sizing of piping, consult the utility having jurisdiction.

A drip leg should be installed in the vertical pipe run to the unit. In some localities, codes may require that a manual main shutoff valve and union (furnished by installer) be installed external to the unit. Union must be of the ground joint type. See figure 6.

A 1/8" NPT plugged tap must be installed immediately upstream of the gas supply connection to the heater.

NOTE – Compounds used on threaded joints of gas piping must be resistant to the actions of liquefied petroleum gases.

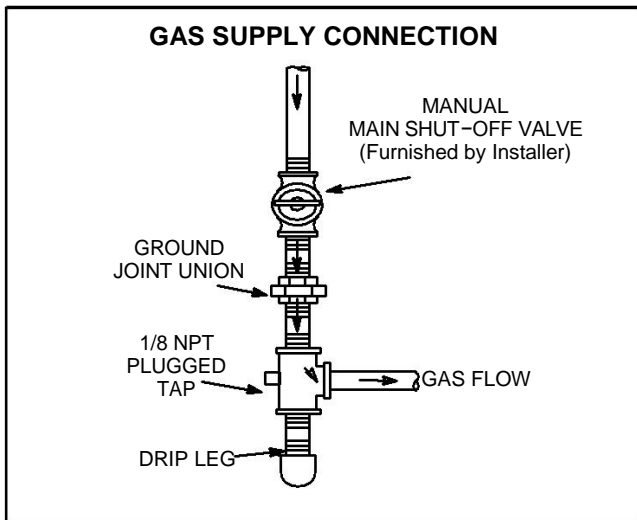

FIGURE 6

Leak Check

After gas piping is completed, carefully check all piping connections, (field and factory), for gas leaks. Use a soap solution or other preferred means.

⚠ CAUTION

DO NOT use matches, candles, flame or other sources of ignition to check for gas leaks.

The appliance must be isolated from the gas supply piping system by closing its individual manual gas shutoff valve during any pressure testing of the gas supply system at test pressures equal to or less than 1/2 psig (3.45kPa).

⚠ IMPORTANT

The heater and its individual shut off valve must be disconnected from the gas supply piping system during any pressure testing of that system at test pressures in excess of 1/2 psig (3.45kPa). See figure 7.

NOTE – In case emergency shutdown is required, shut down main gas valve and disconnect main power to unit. These devices should be properly labeled by the installer.

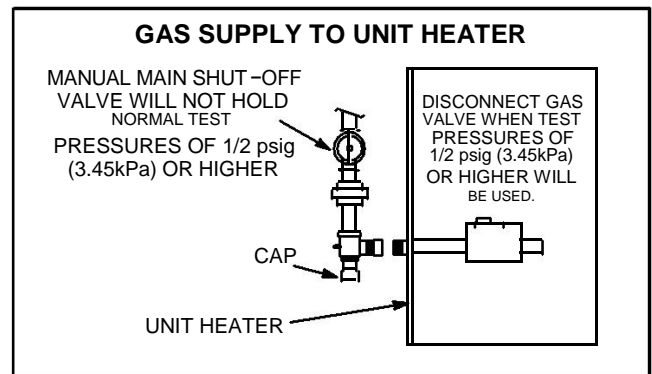

FIGURE 7

Unit Start-Up

FOR YOUR SAFETY READ BEFORE LIGHTING

⚠ WARNING



Electric shock hazard. Can cause injury or death. Do not use this appliance if any part has been under water. Immediately call a qualified service technician to inspect the furnace and to replace any part of the control system and any gas control which has been under water.

⚠ WARNING



Danger of explosion. Can cause injury or product or property damage. If overheating occurs or if gas supply fails to shut off, shut off the manual gas valve to the appliance before shutting off electrical supply.

⚠ WARNING



Electric shock hazard. Can cause injury or death. Before attempting to perform any service or maintenance, turn the electrical power to unit **OFF** at disconnect switch(es). Unit may have multiple power supplies.

⚠ WARNING



Danger of explosion and fire. Can cause injury or product or property damage. You must follow these instructions exactly.

BEFORE LIGHTING smell all around the appliance area for gas. Be sure to smell next to the floor because some gas is heavier than air and will settle on the floor.

Use only your hand to push in or turn the gas control knob. Never use tools. If the knob will not push in or turn by hand, do not try to repair it, call a qualified service technician. Force or attempted repair may result in a fire or explosion.

These unit heaters are equipped with an automatic spark ignition system. There is no pilot. In case of a safety shutdown, move thermostat switch to **OFF**, then return the thermostat switch to HEAT position.

GAS VALVE OPERATION FOR HONEYWELL VR8205/VR8305 SERIES GAS VALVE (FIG 8)

- 1 - STOP! Read the safety information at the beginning of this section.
- 2 - Set thermostat to lowest setting.
- 3 - Turn off all electrical power to appliance.
- 4 - This appliance is equipped with an ignition device which automatically lights burners. **DO NOT attempt to light the burners manually.**
- 5 - Turn the manual knob on gas valve clockwise to **OFF**. Do not force.
- 6 - Wait five minutes to clear out any gas. If you then smell gas, **STOP!** Immediately call your gas supplier from a neighbor's phone. Follow the gas supplier's instructions. If you do not smell gas, go to next step.
- 7 - Turn manual knob on gas valve counterclockwise to **ON**.
- 8 - Turn on all electric power to unit.
- 9 - Set thermostat to desired setting.
- 10 - The combustion air inducer will start. The burners will light within 40 seconds.
- 11 - If unit does not light first time (gas line not fully purged) it will attempt up to two more ignitions before locking out.
- 12 - If lockout occurs, repeat steps 1 through 8.
- 13 - If appliance still will not operate, follow the instructions "**To Turn Off Gas to Unit**" and call your service technician or gas supplier.

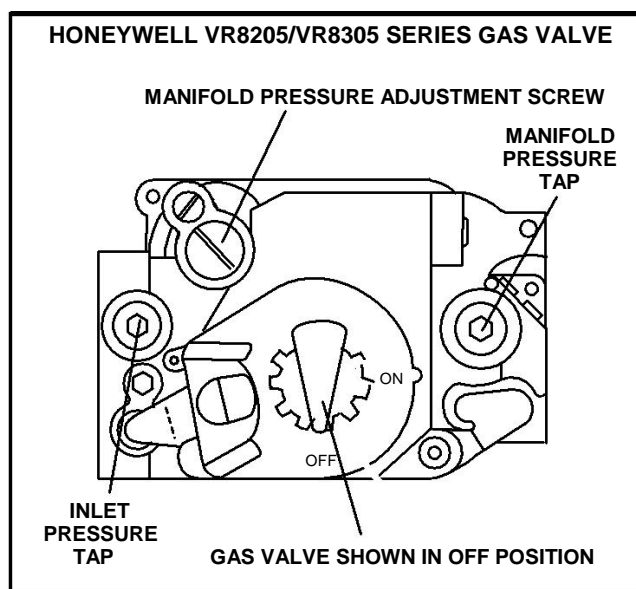



FIGURE 8

To Turn Off Gas to Unit

- 1 – Set thermostat to lowest level.
- 2 – Turn off all electrical power to unit if service is to be performed.
- 3 – Turn knob on gas valve 90° clockwise  to OFF.

Heating Sequence of Operation

- 1 – When the thermostat calls for heat, the combustion air inducer starts immediately.
- 2 – Combustion air pressure switch proves inducer operation before allowing power to the ignition controller. This switch is factory-set and no adjustment is necessary.
- 3 – After prepurge of approximately 30 seconds, the spark ignition is energized and the solenoid valves open in the gas valve. SEP models 230, 250, 300, 345 and 400 are equipped with a step opening valve. During ignition phase of start-up, a pressure of approximately 25% of full rate allows even ignition of all burners for several seconds before full rate pressure is established.
- 4 – The spark then ignites the gas, the ignition sensor proves the flame, and the combustion process continues.
- 5 – in the event that the flame is not detected after the first 10-second trial for ignition, the controller will repeat steps 3 and 4 an additional two times before locking out the gas valve. Ignition control will then automatically repeat steps 3, 4, and 5 after 60 minutes.

NOTE: To interrupt the 60-minute lockout period, move thermostat from "Heat" to "OFF" then back to "Heat." Heating sequence then restarts at step 1.

- 6 – The burners must light without noticeable crossover delay. There must be no flame lifting from the burner heads, flashback or burning within the burner. The flames should be predominantly blue in color and should be approximately centered in the tubes with no apparent impingement taking place.
- 7 – The ignition control will energize the fan(s) approximately 45 seconds after ignition is established.
- 8 – After the thermostat demand is satisfied, the gas valve is closed. Five seconds after the demand is satisfied, the combustion air inducer is shut off.
- 9 – The ignition control must shut off the system fan approximately 150 seconds after the gas valve is de-energized.

Ignition Control LED

The ignition control contains a green LED which indicates the following:

**TABLE 8
IGNITION CONTROL LED**

LED	UNIT OPERATION
Slow Flash*	Normal Operation – No call for heat
Fast Flash	Normal Operation – Call for heat
2 Flashes	System lockout – failed to detect or sustain flame
3 Flashes	Pressure switch failed closed before CAI is energized or failed open after CAI is energized
4 Flashes	High limit or rollout switch open
5 Flashes	Flame sensed and gas valve not energized
Steady Off	Loss of power
Steady On	Ignition control failure

*When thermostat is placed in continuous fan mode, LED will slowly flash.

High Altitude Adjustment

In Canada, certification for installation at altitudes over 4500 feet (1372m) above sea level is the jurisdiction of the local authorities.

Unit may be fired at full input up to 2000 feet (610m) above sea level. Above 2000 feet (610m), manifold pressure must be adjusted on some units. Adjust pressure regulator to pressure shown in table 9 for natural gas and table 10 for LP/propane gas.

In some cases, it is necessary to change the pressure switch to ensure proper operation at higher altitudes. See table 1.

NOTE – A natural to LP/propane gas changeover kit is required to convert the unit in the field. Refer to the installation instructions supplied with the changeover kit for conversion procedure.

If unit is installed at an altitude greater than 7500 feet (2286m), unit must be derated by four percent for each additional 1000 feet (305m) above 7500 feet (2286m).

The combustion air inducer proving switch is factory set and no adjustment is necessary.

**TABLE 9
NATURAL GAS MANIFOLD PRESSURES – in. w.g. (kPa)**

SEP UNIT	ALTITUDE – FEET (METERS)						
	0–2000 (0–610)	2001– 2500 (610–762)	2501 –3500 (763–1067)	3501 – 4500 (1067–1372)	4501 – 5500 (1372–1676)	5501 – 6500 (1677–1981)	6501 – 7500 (1981–2286)
SEP-100** SEP-115** SEP-300	3.5 (0.87)	3.5 (0.87)	3.5 (0.87)	3.5 (0.87)	3.4 (0.84)	3.3 (0.82)**	3.2 (0.79)**
SEP-145**	3.5 (0.87)	3.4 (0.84)	3.3 (0.82)	3.2 (0.79)	3.1 (0.77)	3.0 (0.74)**	2.9 (0.72)**
SEP-175* SEP-230	3.5 (0.87)	3.5 (0.87)	3.5 (0.87)*	3.5 (0.87)*	3.5 (0.87)*	3.5 (0.87)*	3.5 (0.87)*
SEP-200 SEP-250 SEP-345 SEP-400	3.5 (0.87)	3.5 (0.87)	3.5 (0.87)	3.4 (0.84)	3.3 (0.82)	3.2 (0.79)	3.1 (0.77)

* The SEP-175 unit requires pressure switch change when installed at elevations above 2500 feet (762m). Order pressure switch 176722600. No adjustment to switch is required.

* SEP models -100, -115 and -145 require pressure switch change when installed at elevations above 5500 feet (1676m). Order pressure switch 176722600. No adjustment to switch is required.

**TABLE 10
LP/PROPANE GAS MANIFOLD PRESSURES – in. w.g. (kPa)**

SEP UNIT	ALTITUDE – FEET (METERS)						
	0–2000 (0–610)	2001– 2500 (610–762)	2501 –3500 (763–1067)	3501 – 4500 (1067–1372)	4501 – 5500 (1372–1676)	5501 – 6500 (1677–1981)	6501 – 7500 (1981–2286)
SEP-100** SEP-115** SEP-300	9.0 (2.24)	9.0 (2.24)	9.0 (2.24)	9.0 (2.24)	8.7 (2.16)	8.4 (2.09)**	8.1 (2.01)**
SEP-145**	9.0 (2.24)	8.7 (2.16)	8.4 (2.09)	8.1 (2.01)	7.8 (1.94)	7.5 (1.86)**	7.2 (1.79)**
SEP-175* SEP-230	9.0 (2.24)	9.0 (2.24)	9.0 (2.24)*	9.0 (2.24)*	9.0 (2.24)*	9.0 (2.24)*	9.0 (2.24)*
SEP-250	9.0 (2.24)	9.0 (2.24)	9.0 (2.24)	8.7 (2.16)	8.4 (2.08)	8.1 (2.01)	7.8 (1.94)
SEP-200 SEP-345 SEP-400	9.5 (2.37)	9.5 (2.37)	9.5 (2.37)	9.2 (2.28)	8.9 (2.21)	8.6 (2.13)	8.3 (2.06)

* The SEP-175 unit requires pressure switch change when installed at elevations above 2500 feet (762m). Order pressure switch 176722600. No adjustment to switch is required.

* SEP models -100, -115 and -145 require pressure switch change when installed at elevations above 5500 feet (1676m). Order pressure switch 176722600. No adjustment to switch is required.

Gas Flow

To check for proper gas flow to the combustion chamber, determine the Btu input from the appliance rating plate.

Divide this input rating by the Btu per cubic feet of available gas. Result is the required number of cubic feet per hour. Determine the flow of gas through the gas meter for two minutes and multiply by 30 to get the hourly flow of gas.

Gas Pressure Adjustment

- 1 - Check gas line pressure with unit firing at maximum rate. A minimum of 5" (127mm) w.c. for natural gas or 11" (279mm) w.c. for LP/propane gas should be maintained for proper unit operation.
- 2 - After line pressure has been checked and adjusted, check regulator pressure. Adjust manifold pressure to values specified on the unit rating plate. See figures 8, 9, and 10 for gas pressure adjustment screw location. A natural gas to LP/propane gas changeover kit is required to convert unit in the field. Refer to installation instructions provided with changeover kit for conversion procedure.

Limit Control Switch

The limit control switch(es) are factory-set and are not field-adjustable.

Louver Vane Adjustment

The SEP series unit heaters are provided with adjustable louver vanes. Air flow from the unit can be directed down, straight, out, up, or any combination of these.

⚠ WARNING



DO NOT CLOSE the bottom three louvers on SEP. Premature failure to the heat exchanger can occur.

Combustion Air Pressure Switch

This pressure switch checks for proper combustion air inducer operation before allowing an ignition trial. The switch is factory-set and no field adjustment is necessary.

Service

⚠ CAUTION

Turn off gas and electrical power to unit before performing any maintenance or service operations on this unit. Remember to follow lighting instructions when putting unit back into operation after service or maintenance.

The unit heater and vent system shall be inspected once a year by a licensed professional service technician, or equivalent.

LUBRICATION

- 1 - Combustion air inducer motor bearings are pre-lubricated and sealed. No further lubrication is necessary.
- 2 - Fan motor bearings should be lubricated according to manufacturer's instructions on each motor. If no instruction is provided, use the following as a guide: motors with oiling ports are pre-lubricated for an extended bearing life, re-lubricate with a few drops of SAE No. 10 non-detergent oil once every two years.

BURNERS

- 1 - Periodically examine burner flames for proper appearance during the heating season.
- 2 - Before each heating season examine the burners for any deposits or blockage that may have occurred.
- 3 - Clean burners as follows:
 - a - Turn off both electrical and gas supplies to unit.
 - b - Disconnect gas supply piping, high tension and sensor leads. Remove gas manifold. Remove burner tray.
 - c - Clean burners as necessary. Make sure that burner heads line up properly to ensure flame crossover. Check spark gap on electrode and adjust if required. The gap should be between 0.110" and 0.140" (2.8 mm to 3.6 mm). The gap may be checked with appropriately sized twist drills or feeler gauges.
 - d - Reinstall burner tray, gas manifold, high tension and sensor leads. Reconnect gas supply piping.
 - e - Restore electrical power and gas supply. Follow lighting instructions to light unit. Check burner flame.

FLUE PASSAGEWAY AND FLUE BOX

The flue passages and flue box should be inspected and cleaned prior to each heating season. The sequence of operation should be as follows:

- 1 – Turn off both electrical and gas supply to unit.
- 2 – Disconnect combustion air inducer wiring.
- 3 – Remove screws securing flue box to unit. Remove flue box. If necessary, remove blower assembly from flue box. Clean flue box with wire brush.
- 4 – Remove baffle retention bracket and flue baffles. Clean flue baffles with wire brush.
- 5 – Remove burners as described in Burners" section.
- 6 – Clean tubes with a wire brush.
- 7 – Reassemble unit. The combustion air and flue box gaskets should also be replaced during reassembly.
- 8 – Restore electrical power and gas supply. Follow lighting instructions to light unit. Check operation of unit.

COMBUSTION AIR INDUCER

Under normal operating conditions, the combustion air inducer should be checked and cleaned prior to the heating season with the power supply disconnected. Use a small brush to clean inducer wheel.

ELECTRICAL

- 1 – Check all wiring for loose connections.
- 2 – Check for correct voltage at unit (unit operating).
- 3 – Check amperage draw.

FLUE AND CHIMNEY

Check all vent and vent connector joints for tightness. Ensure that connections are sealed and that there are no blockages.

FAILURE TO OPERATE

If unit fails to operate check the following:

- 1 – Is thermostat calling for heat?
- 2 – Is main disconnect closed?
- 3 – Is there a breaker tripped or a fuse blown?
- 4 – Is gas turned on at meter?
- 5 – Is manual shutoff valve open?
- 6 – Is unit ignition system in lock out? If unit locks out again, call service technician to inspect unit.
- 7 – Is pressure switch closed? Obstructed flue will cause unit to shut off at pressure switch. Check flue passage and outlet.

SAFETY SHUT-OFF VALVE TEST

The safety shut-off valve test procedure is as follows:

- 1 – Turn off the manual gas valve.
- 2 – Set the thermostat to call for heat.
- 3 – System begins normal sequence of operation.
- 4 – After approximately 30 seconds (pre purge period) the LED will fast flash indicating the gas valve is powered.
- 5 – After 10 seconds, the gas valve closes and steps 4 and 5 will repeat two additional times before locking out the gas valve, which will be indicated by two flashes on the LED.
- 6 – To restart the system, de-energize the thermostat call for heat and follow the operating instructions under Unit Start-Up".

REPAIR PARTS

When ordering repair parts include the complete unit model number listed on the unit rating plate. For example: SEP-175A-1.

START-UP AND PERFORMANCE CHECKLIST

Job Name: _____	Job No.: _____	Date: _____
Job Location: _____	City: _____	State/Province: _____
Installer: _____	City: _____	State/Province: _____
Unit Model No.: _____	Serial No.: _____	Service Technician: _____
Electrical Connections Tight? _____	Air Shutters Properly Adjusted (If Installed)? _____	
Supply Voltage _____	Flue Connections Tight? _____	
Blower Motor Lubrication O.K.? _____	Fan Timer Operation Checked? _____	
Gas Piping Connections Tight & Leak-Tested? _____	THERMOSTAT	
Blower Motor Amps _____	Calibrated? _____	
Furnace Btu Input _____	Heat Anticipator Properly Set? _____	
Line Pressure _____	Level? _____	
Manifold Pressure _____ w.c.		

TEMPLATE
Location of Combustion Air Inducer Mounting Holes for
Rotated Inducer

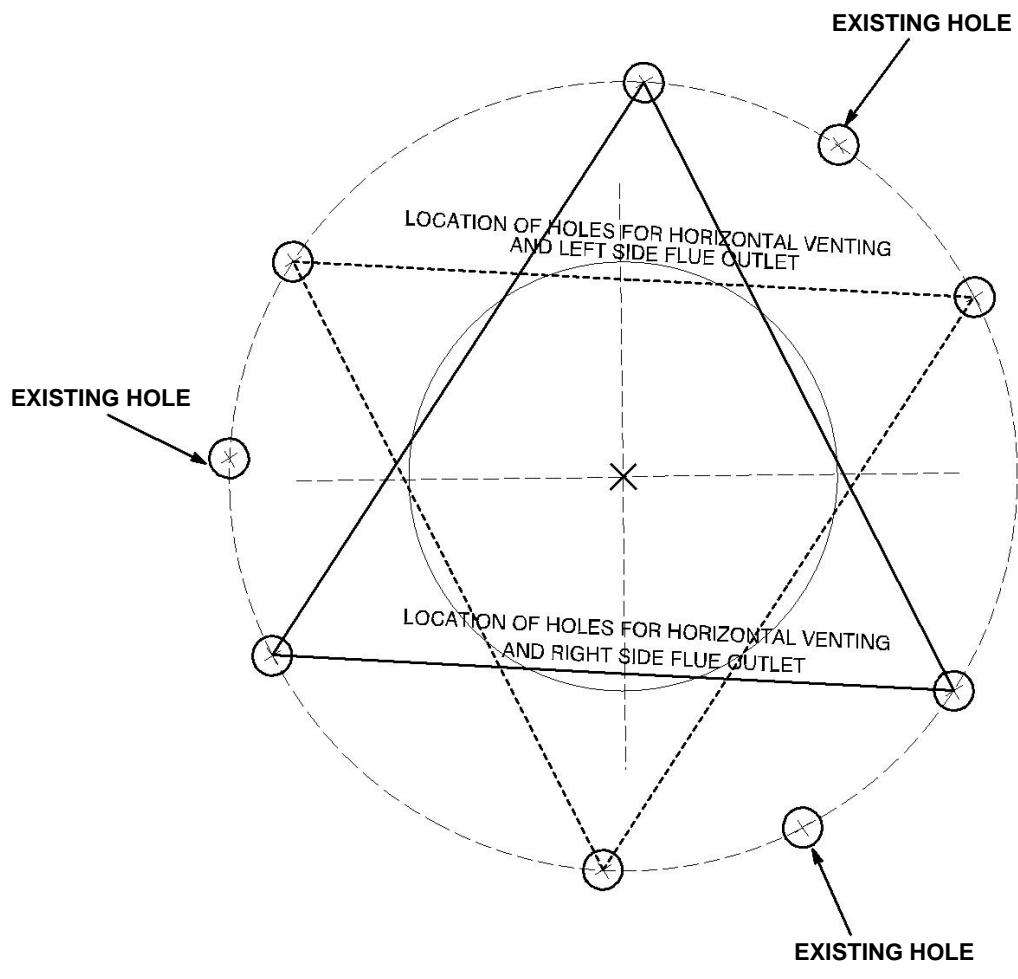



Unit Heater Limited Warranty – Standard 2 Year

(Applies only to product installed within the United States or Canada)

Term of Warranty: Advanced Distributor Products (ADP) warrants that products sold shall be of merchandisable quality, free of defects in material and workmanship, under normal use and service, for a period of two (2) years from the date of installation, **not** to exceed three (3) years from the date of manufacture.

Extended Components: This warranty provides extended coverage on Aluminized Heat Exchangers for **ten (10) years** and Stainless Steel Heat Exchangers for **fifteen (15) years**. The extended warranty coverage begins with the installation date and represents the total warranty period for the specific component. ADP, at its option, will furnish a replacement heat exchanger or allow a credit (in the amount of the heat exchanger original selling price) toward the purchase of a new ADP unit heater. **No extended coverage** granted for **HED series** heat exchangers.

Warranty Procedure: Warranty parts should be replaced by a qualified local contractor or dealer and will require the following information: model number, serial number, date of installation and an accurate description of the problem. Contractor or dealer will contact a local ADP distributor for replacement parts.

Replacement Parts: If, during the term of this warranty, a warranted part fails, ADP will either provide a replacement part free of charge, or may at its option, grant a credit for the original purchase price of the defective article to a distributor of ADP products. ADP may require the return of a defective article for factory inspection to verify and/or determine the root cause of the failure. Covered components include all parts of this unit except for the following **excluded components**, which are not covered by this warranty: cabinet, cabinet pieces, wiring and wiring harnesses.

Care of Equipment: For this warranty to apply, ADP product must be properly installed, operated, and maintained in accordance with the installation, operation and maintenance instructions provided with each unit. Unauthorized alteration of ADP product may void this warranty.

Conditions of Warranty: Replacement parts furnished under this warranty will be warranted for the balance of the original warranty term of the unit (including any extended warranty) and will not serve to extend the original term. This warranty is void if the ADP product is removed from the original installation site. This warranty does not apply to damage caused by shipping, misuse, mishandling or damage caused by floods, winds, fires, lightning, or exposure to corrosive elements/environments (such as salt, chlorine, fluorine or other damaging chemicals).

Limitations of Warranty: The costs of miscellaneous material and labor charges for diagnostics, servicing or replacing parts are not covered. ADP shall have no liability for expenses incurred for repairs without prior, written authorization from ADP.

The foregoing is in lieu of all other warranties, express or implied, notwithstanding the provisions of the Uniform Commercial Code, the Magnuson-Moss Warranty-Federal Trade Commission Improvement Act, or any other statutory or common law, federal or state.

ADP makes no warranty, express or implied, of fitness for any particular purpose, or of any other nature whatsoever, with respect to products manufactured or sold by ADP hereunder, except as specifically set forth above and on the face hereof. It is expressly understood and agreed that ADP shall not be liable to buyer, or any customer of buyer, for direct or indirect, special, incidental, consequential or penal damages, or for any expenses incurred by reason of the use or misuse by buyer or third parties of said products. To the extent said products may be considered "consumer products", as defined in Sec. 101 of the Magnuson-Moss Warranty-Federal Trade Commission Improvement Act, ADP makes no warranty of any kind, express or implied, to "consumers," except as specifically set forth above on the face hereof.

2175 West Park Place Boulevard
Stone Mountain, Georgia 30087
www.adpnow.com



Advanced Distributor Products[®]

Solutions for Your needs

2175 West Park Place Boulevard
Stone Mountain, GA 30087
www.adpnow.com