



## Installation Instructions

# Evaporator Coil

TABLE OF CONTENTS	PAGE
General .....	1
Vertical .....	2
Horizontal .....	2
Multi-Position .....	3-5
Metering Device .....	6
Condensate Drain .....	7
Refrigerant Line Installation .....	8
Refrigerant Charging Instructions .....	8
Installation Check List .....	8



## GENERAL

ADP evaporator coils are designed for use with AC condensing units or heat pump units. These instructions are intended as a general guide and do not supersede local codes in any way. Consult with local authorities having jurisdiction before installation. **Read this installation manual and all safety messages prior to installing the evaporator coil.**

Check coil for shipping damage and verify the contents of the box containing the evaporator coil. If you should find damage, immediately contact the last carrier. Verify the efficiency performance requirements, such as SEER, EER, and/or HSPF, are appropriate with the matched condensing or heat pump units. Check outdoor unit manufacturer for proper line sizing. **Coils are shipped with a 10 psi dry air holding charge. Puncture rubber plug on suction line to release charge before removing plugs.** The absence of pressure does not verify a leak. Check the coil for leaks before installing or returning it to your wholesaler.

Position the coil on the outlet of the furnace using sheet metal screws. Drain pans are made of a polymer that can withstand temperatures up to 450°F. **Maintain a 3" clearance on oil or drum type heat exchangers and 1½" on sectionalized heat exchangers.** Coil should be level, or pitched slightly toward the drain connection. **Airflow face velocity above 350 ft/min is not recommended for downflow or counterflow applications due to potential water blow-off.** Refer to Specification Guide for limitations.

### SAFETY CONSIDERATIONS

Your safety and the safety of others are very important.

We have provided many important safety messages in this manual and on your appliance. Always read and obey all safety messages.



This is the safety alert symbol.

This symbol alerts you to potential hazards that can kill or hurt you and others.

All safety messages will follow the safety alert symbol and signal word. These signals words mean the following:

**DANGER:** You can be **killed or seriously injured** if you don't immediately follow instructions.

**WARNING:** Indicate a potentially hazardous situation which, if not avoided, could result in **death or serious injury**.

**CAUTION:** Indicates a potentially hazardous situation which, if not avoided, may result in **minor or moderate injury**. Caution may also be used to alert against unsafe practices.

**NOTICE:** Indicates a statement of company policy as the message relates directly or indirectly to the safety of personnel or protection of property.

**IMPORTANT:** More detailed information concerning the statement of company policy as the message relates directly or indirectly to the safety of personnel or protection of property.

All safety messages will tell you what the potential hazard is, tell you how to reduce the chance of injury, and tell you what can happen if the instructions are not followed.



ISO 9001:2008  
Registered Quality System



\*\* Note: Large tonnage coils (greater than 5 tons) are not AHRI certified and do not have Microban® protection.

Product improvement is a continuous process at Advanced Distributor Products. Therefore, product specifications are subject to change without notice and without obligation on our part. Please contact your ADP representative or distributor to verify details.

© by Advanced Distributor Products. All rights reserved.

## VERTICAL

Vertical A-Coils are designed for upflow and downflow applications. Vertical drain pans have drain connections on the right and left front side of the evaporator coil. **Airflow face velocity above 350 ft/min is not recommended for downflow applications due to potential water blow-off.**

Refer to Specification Guide for limitations. In downflow applications, aluminum foil tape must be applied to seal the top edge of the insulation to the cabinet. This tape will prevent the possibility of the insulation delaminating and blocking airflow.

## HORIZONTAL

Horizontal A-Coils and Slab Coils are designed for horizontal applications only. Horizontal A-Coils 17.5" and taller include furnace plate adaptors to facilitate proper fit with furnaces of different widths.

- Proper performance for **Horizontal A-Coils with top connections** requires that the air flows out through the side of coil where the top connections are located (Figure 1).

- **Horizontal A-Coils with side connections** are bidirectional.
- For **Horizontal A-Coils with side connections**, the suction line section inside the cabinet should be insulated with Armaflex<sup>®</sup> insulation (Figure 2).
- **Slab Coils** are bidirectional and require a transition duct to complete installation.

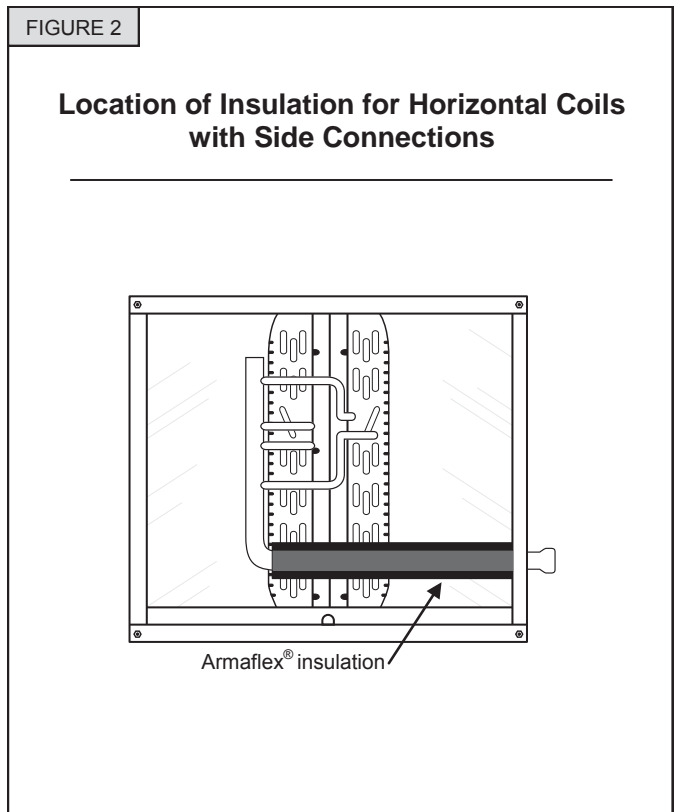
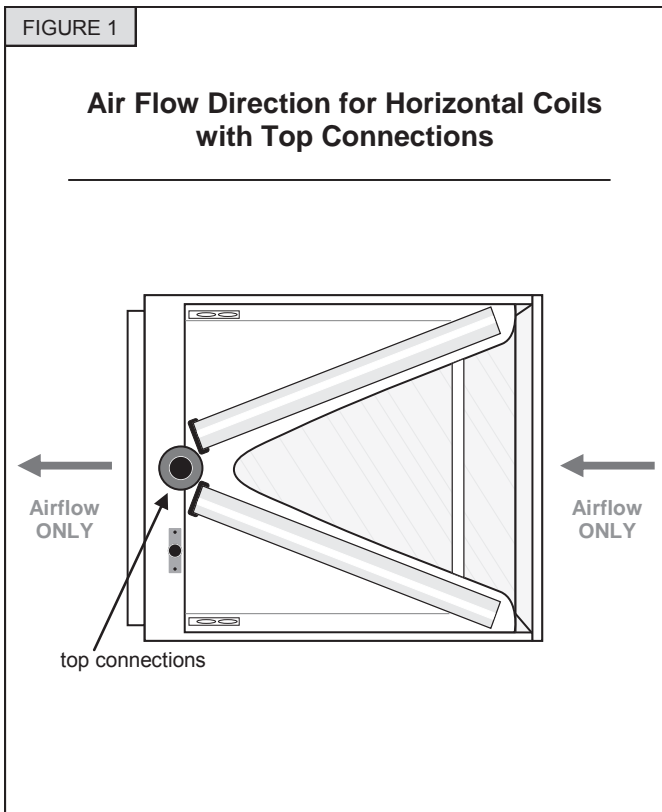

## MULTI-POSITION

Multi-Position A-Coils come factory installed with a vertical and horizontal drain pans and can be configured for upflow, downflow, horizontal blow-through or horizontal pull-through installations. In the center opening of vertical drain pan, a metal Inlet Air Restrictor is factory installed and is required for horizontal applications. It may be removed for vertical applications. **Airflow face velocity above 350 ft/min is not recommended for downflow or counterflow applications due to potential water blow-off.** Refer to Specification Guide for limitations.

For horizontal configurations, install splashguard (included) onto the coil outlet, and extend suction line insulation into the coil cabinet by 2" to prevent moisture from dripping onto the insulation (the rubber grommet may need to be moved). Splashguard installation is not required for vertical configurations. Bottom flange of guard should rest on pan and sides screwed to the duct flanges. See page 4, Figures 4 and 5 for splashguard instructions.

In downflow and counter flow configurations, aluminum foil tape must be applied to seal the top edge of the insulation to the cabinet. This tape will prevent the possibility of the insulation delaminating and blocking airflow. In horizontal pull-through and counter flow configurations, a minimum 12" transition is required in front of the coil as shown in Figure 3. This is required to ensure proper airflow distribution and to reduce pressure drop.

Coils that are 20" or less in height and are installed in a cabinet with a height of 25-1/2" or greater do not require a transition; all other coil models require this transition. Coil should be level, or pitched slightly toward the drain connection. It is recommended to add silicone caulk between drain pans to prevent water carryover. **Note:** Multi-Position A-Coils are also field convertible from left-to-right or right-to-left; see page 5 for instructions on field conversion for horizontal airflow.

Additional pre-startup checklist for Multi-Position A-Coils.

- Install splash guard (Figure 3 configurations A and B)
- Install 12" transition as shown (non-standard horizontal applications / Figure 3 configurations B and C)
- Factory installed Inlet Air Restrictor should be present in the center opening of the drain pan (horizontal applications)
- Factory installed internal water diverter should be in place (Figure 6, item 5)
- Extend suction line insulation into cabinet (counter flow)
- Tape top edge of insulation (counter flow)

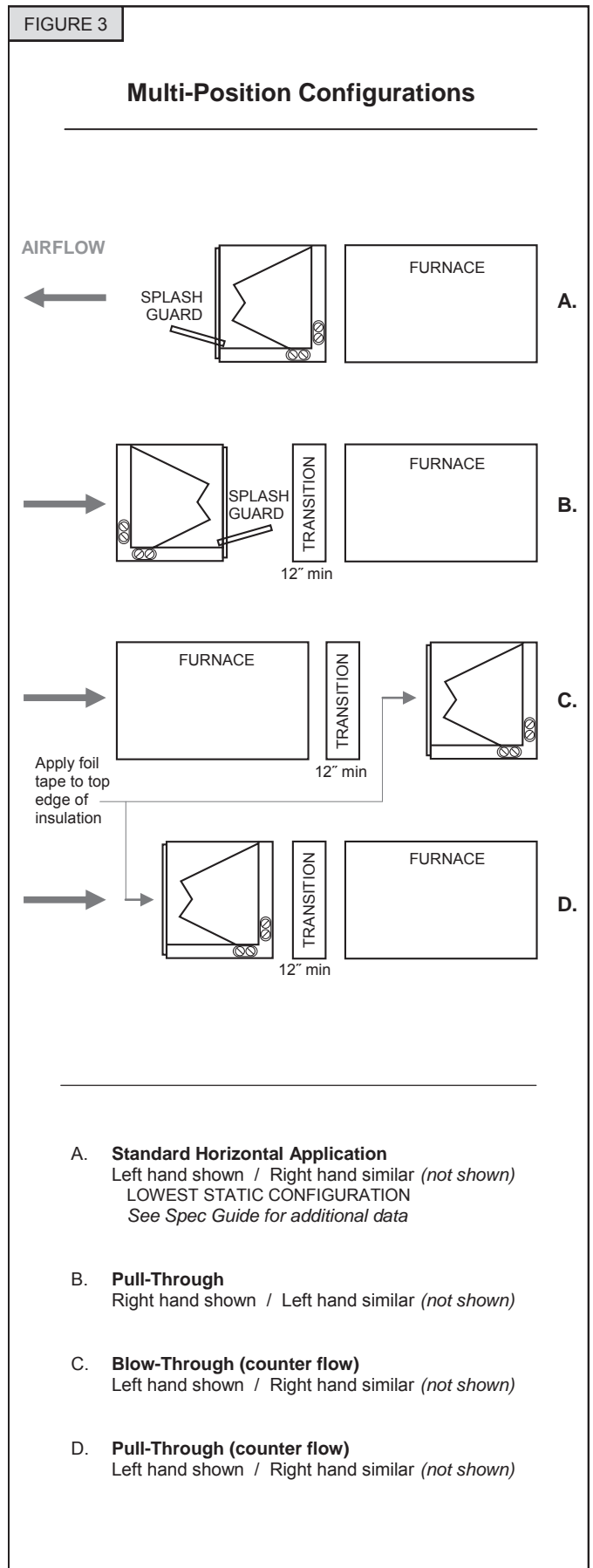

# MULTI-POSITION (splashguard)

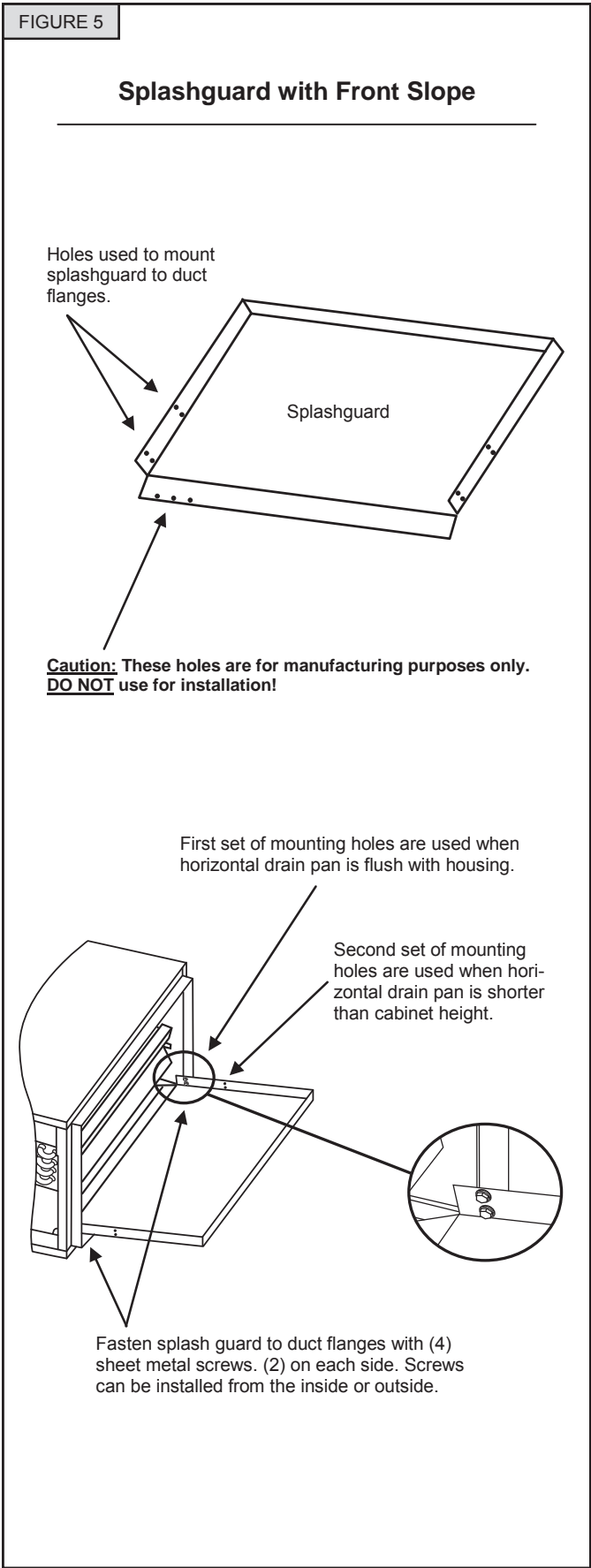
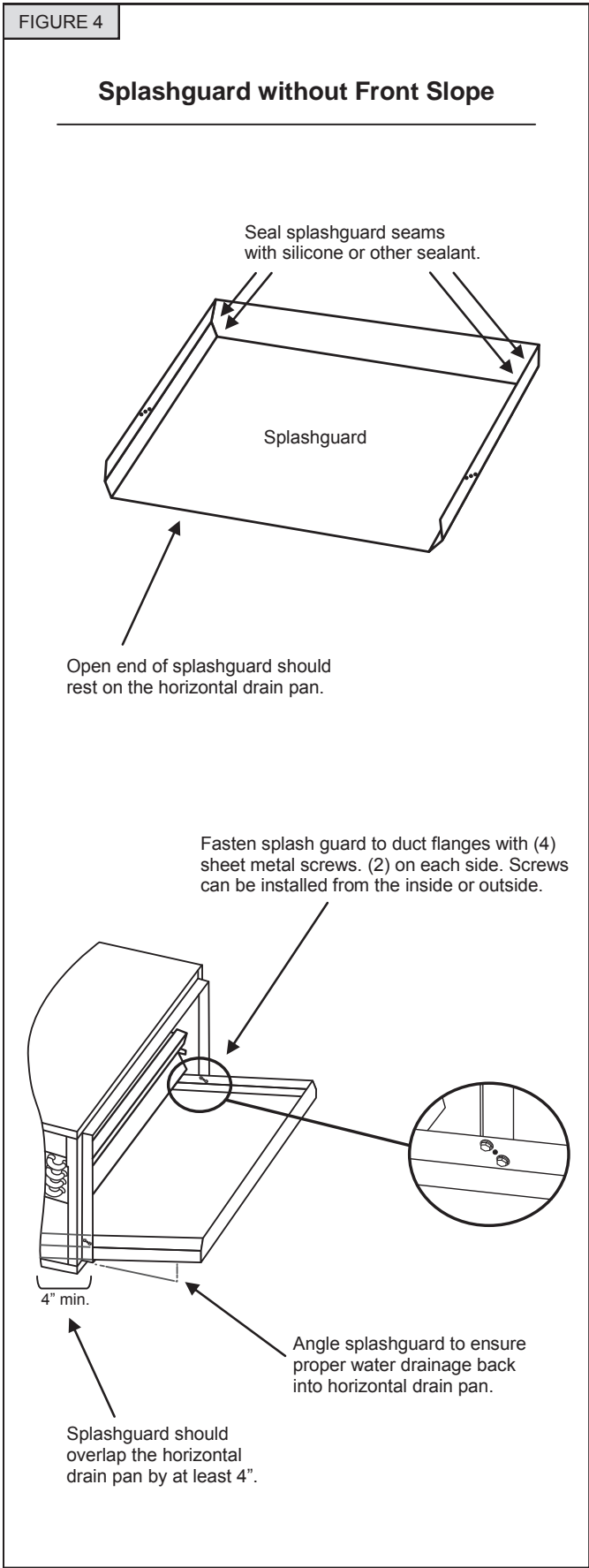

## MULTI-POSITION (field conversion)

### Field Conversion Instructions from Left-to-Right or Right-to-Left Airflow

**Note:** This applies only to models available in multi-position; see Specification Guide for details; typical horizontal left-to-right conversion is shown.

#### FOR EACH STEP, REFER TO FIGURE 6:

1. Remove front panels.
2. Remove the top tie bar and pull the coil assembly from the housing.
3. Remove the horizontal drain pan, and re-install it to the opposite side of the coil (**Note:** horizontal drain pan must have drain plugs tightly closed in the rear of the unit).
4. Remove the top plate.
5. Remove the water diverter, and re-install it to the opposite slab (**Note:** If water diverter is attached by screws, remove screws, and bend tab straight or cut tab off).
6. Replace the top plate, and apply sealant to seal any air gaps.
7. Before re-inserting the coil assembly, cut the front flange on the housing and fold it back to allow access to the horizontal drain connections (**Note:** Copy the factory cut-out on the opposite side of the housing).
8. Slide the coil assembly back into the housing (**Note:** If unit is equipped with a sheet metal spacer, it must be moved to the opposite side of the housing).
9. Re-install the top tie bar.
10. Re-install the piping panel to the housing.
11. Cut a hole in the access panel to allow access to the horizontal drain connections, and re-install the access panel to the housing (**Note:** Access panel may need to be notched to allow access to suction header).
12. Seal unused condensate drain connection cutout holes in the front panel to prevent air leakage.

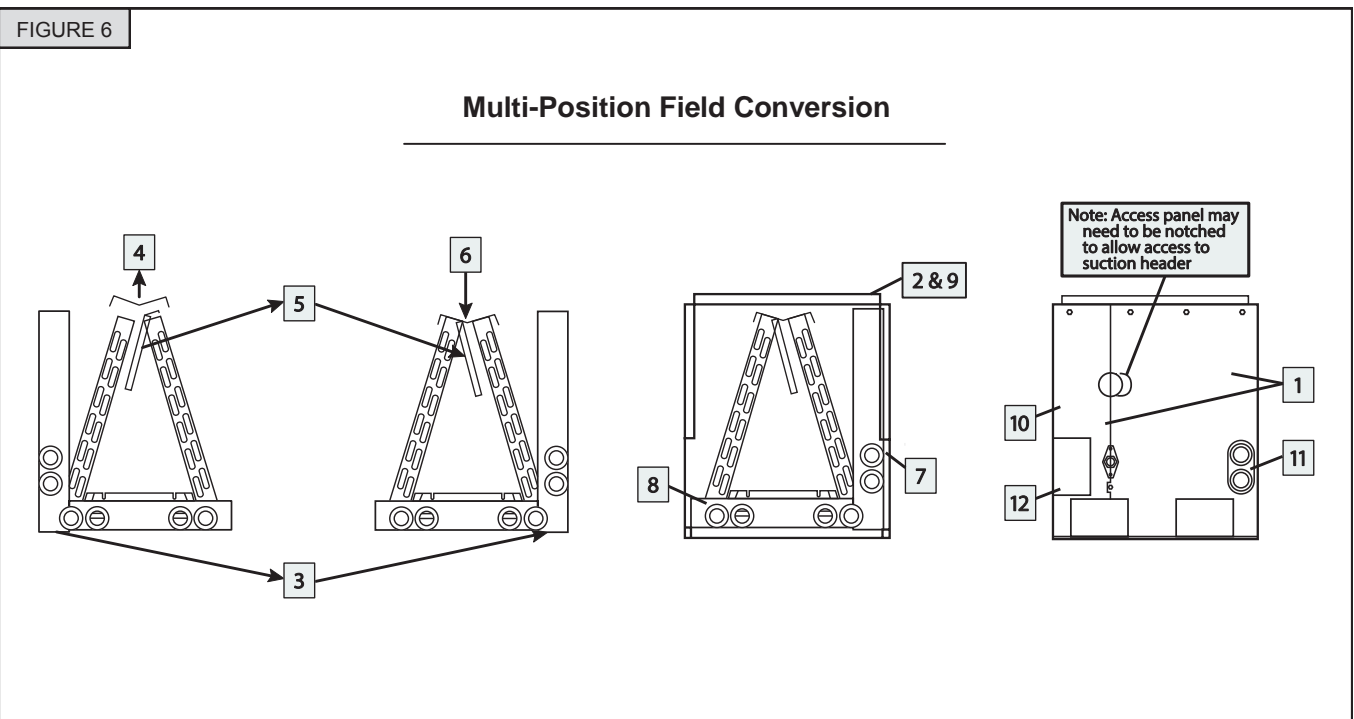

## METERING DEVICE

Coils are suited for R-22 and R-410A refrigerants and can be used with a piston or a TXV. Replacement TXV part numbers are listed below; see kit instructions for change out or installation. ADP recommends placing a wet rag around the suction line at the cabinet during brazing to prevent overheating and damaging the sensing bulb.

For optimum performance, reattach and insulate the bulb at a 10 to 2 o'clock position outside of the cabinet to the main suction line no more than one foot from the suction line connection. When changing a system from AC to heat pump or heat pump to AC, check the current TXV specifications to determine if a TXV replacement is required. **If the evaporator coil contains a non-bleed TXV and is used with a condensing unit containing a reciprocating compressor, a hard start kit will be required on the condensing unit.**

Large Tonnage A-Coils of 7.5 Ton (R-410A) cooling capacity include an adjustable TXV that can be used to fine tune superheat. Turn adjustment clockwise to increase superheat 4°F per turn and counter-clockwise to decrease superheat 4°F per turn. To return to factory setting, turn adjustment stem counterclock-wise until the spring is completely unloaded (reaches stop or starts to "ratchet"). Then, turn it back 6 "total turns".

R-22 TXV Part Numbers	
18-36 MBTUH Bleed A/C	65540600
42-60 MBTUH Bleed A/C	65540700
18-36 MBTUH Non-Bleed A/C	99167501
42-60 MBTUH Non-Bleed A/C	99167502
18-36 MBTUH Non-Bleed A/C-HP	65616201
42-60 MBTUH Non-Bleed A/C-HP	65616202

R-410A TXV Part Numbers	
18-36 MBTUH Non-Bleed A/C	65026401
42-60 MBTUH Non-Bleed A/C	65026400
18-36 MBTUH Non-Bleed A/C-HP	65616601
42-60 MBTUH Non-Bleed A/C-HP	65616602



IMPORTANT



When changing the metering device, ensure the metering device matches the refrigerant type and capacity of the condensing unit. Failure to do so will result in poor performance and possible compressor damage. All coils must be matched properly as listed in the AHRI directory.

Cased coils with a piston metering device are shipped with a cap and hex nut over the threaded fitting. Remove the cap and nut slowly, allowing charge to escape, and secure the liquid line stub (attached to cabinet) to the distributor assembly with hex nut. Discard cap.

For optimum performance, the piston should be sized to match the recommendation from the outdoor unit manufacturer. If the outdoor unit manufacturer does not recommend a piston size, refer to the piston size chart. When changing pistons, refer to Figure 7 and use the following procedure:

1. Loosen hex nut located on liquid line and separate from distributor assembly.
2. Remove the existing piston from inside the distributor assembly.
3. Insert the desired piston into the distributor assembly.
4. Inspect Teflon O-Ring and replace if damaged. Ensure Teflon O-Ring is in place.
5. Re-install hex nut to body and torque to 10 ft-lbs.

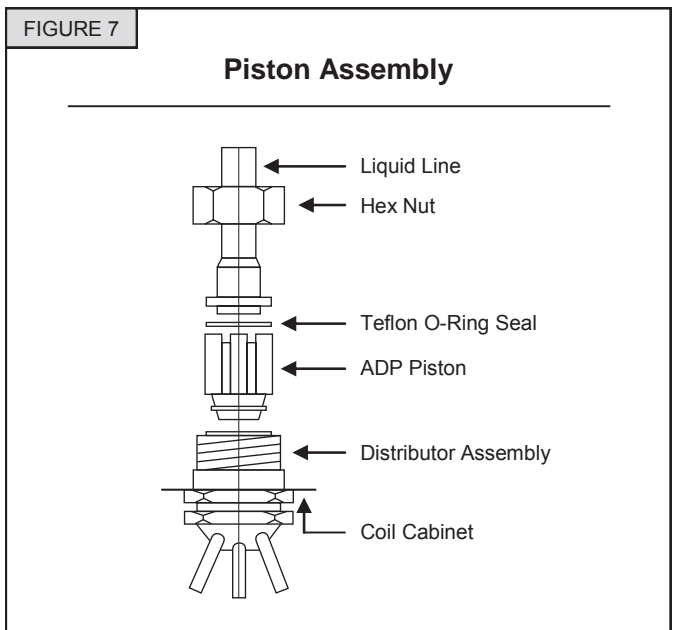

Piston Size				
Ton	R-22		R-410A	
	Piston Size	Part #	Piston Size	Part #
1	41	100000035	41	100000035
1.5	53	100000036	49	100000049
2	59	100000037	53	100000036
2.5	67	100000039	59	100000037
3	73	100000041	67	100000039
3.5	80	100000044	73	100000041
4	84	100000045	76	100000042
5	93	100000047	93	100000047

## CONDENSATE DRAIN

Coils are equipped with multiple drain connections. Determine the drain connections to be used and note the difference between the primary (green) and secondary (red) openings. Drain plugs are provided for all openings; remove and discard the appropriate plugs with  $\frac{1}{2}$ " drive ratchet and verify that remaining plugs are tight (2.5 ft-lbs). Attach drain line to pan with  $\frac{3}{4}$ " male pipe thread PVC fittings. Hand tight is adequate – **do not over tighten & do not reduce drain line size!**

Route drain(s) line so they will not be exposed to freezing temperatures and do not interfere with accessibility to the coil, air handling system or filter. The drain should be pitched downward 1" per 10' with a 2" trap as close to the coil as possible. If line makes a second trap, or has an extended run before termination, a vent tee should be installed after the trap closest to the pan. See Figure 8.

If the coil is located in or above a living space where damage may result from condensate overflow, a separate  $\frac{3}{4}$ " drain must be provided from the secondary drain connection. Run this drain to a place in compliance with local installation codes where it will be noticed when unit is operational. Condensate flowing from the secondary drain indicates a plugged primary drain. Prime the trap with water. Test line for leaks. Test water flow with unit in operation. **An auxiliary drain pan should also be installed under the unit as specified by most local building codes.**

FIGURE 8

### Condensate Drain

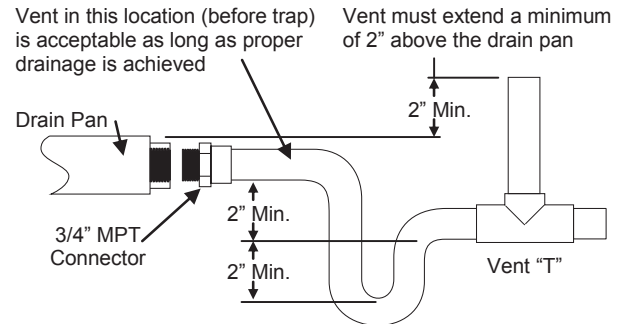

### WARNING



This product may contain fiberglass wool insulation. Glass wool fibers are known to the State of California to cause cancer. Disturbing insulation during installation, maintenance, or repair may expose you to glass wool fibers and may cause respiratory, skin or eye irritation. For further information on risks associated with fiberglass wool, consult Material Safety Data Sheet available from OEM.



### IMPORTANT



The Clean Air Act of 1990 bans the intentional venting of refrigerant (CFC's and HFC's). Approved methods of reclaiming must be followed. Fines and/or incarceration may be levied for non-compliance.



## REFRIGERANT LINE INSTALLATION

ADP recommends installing a filter drier and sight glass in the liquid line. While brazing, purge the system with Nitrogen to prevent contamination. ADP recommends reattaching and insulating the TXV sensing bulb at a 10 to 2 o'clock position on the suction line, outside the coil housing, no more than one

foot from the connection. Evacuate the system to 500 microns to ensure proper air and moisture removal (**Note: Deep evacuation or triple evacuation method recommended**). Open the suction service valve slowly and allow the refrigerant to bleed into the system before opening the liquid service valve.

## REFRIGERANT CHARGING INSTRUCTIONS <sup>1</sup>

When charging in cooling mode, the outdoor temperature should be 60°F or higher. To allow the pressures to stabilize, operate the system a minimum of 15 minutes between adjustments. When adjusting charge to systems with micro-channel outdoor coils, make small (1 ounce or less) adjustments as these systems are very sensitive to refrigerant charge.

**TXV Charging**<sup>2, 3, 4</sup> – Use the charging method recommended by the outdoor unit instructions. Alternatively, ADP recommends charging to 12°F sub-cooling for AC units and 10°F sub-cooling for heat pump units. In addition, if equipped with an adjustable valve, adjust to 10°F superheat.

**Fixed Orifice Charging**<sup>2, 3, 4</sup> – Use the superheat recommended by the outdoor unit instructions. Alternatively, ADP recommends charging to the superheat table below.

Outdoor Air Temp. (°F)	60	65	70	75	80	85	90	95	100	105	110	115
Superheat (°F)	31	28	25	22	20	16	13	10	8	6	5	5

For heat pump units initially charged in the cooling mode, final adjustments to charge in the heating mode are acceptable if

necessary. Some heat pump units require charging in the heating mode. In this case, refer to the outdoor instructions for recommended charging procedures.

If the system is undercharged after the initial charge, add refrigerant until the sight glass is clear and recommended pressures, temperatures, sub-cooling and superheat can be obtained. If the system is overcharged after the initial charge, recover refrigerant until recommended pressures, temperatures, sub-cooling and superheat can be obtained.

### Notes:

1. If any problems or questions regarding charge occur, contact customer service.
2. OEM charging methods vary depending on design and application. Verify all recommended pressures, temperatures, sub-cooling and superheat settings result in the proper charge.
3. ADP coils may require charge compensation due to size variation versus the OEM coil.
4. Temperatures are  $\pm 2^\circ\text{F}$  unless otherwise recommended.

## INSTALLATION CHECKLIST

### Downflow:

- <350 ft/min
- Tape top edge of insulation

### Multi-Position:

- Complete additional checklist on page 3

### Metering Device:

- Verify and/or install correct TXV or piston

### TXV Installation Only:

- Place TXV bulb at 10 to 2 o'clock position
- Insulate bulb
- Connect equalizer line

### Drains:

- Install and trap primary and secondary condensate drains
- If over a finished space, install secondary drain pan

### Air Path:

- Cover any unused knockouts

### Charging:

- Charge per charging instructions

